

FM 1-112

ATTACK HELICOPTER OPERATIONS

DISTRIBUTION RESTRICTION: Approved for public release; distribution unlimited.

HEADQUARTERS, DEPARTMENT OF THE ARMY

ATTACK HELICOPTER OPERATIONS

CONTENTS

| | Paragraph | Page |
|---|------------------|-------------|
| Preface | | v |
| Chapter 1 ATTACK HELICOPTER FUNDAMENTALS | | |
| Roles of the ATKHB | 1-1 | 1-1 |
| Organization | 1-2 | 1-8 |
| Missions, Organizational Capabilities, and Limitations | 1-3 | 1-12 |
| Chapter 2 BATTLE COMMAND | | |
| Command and Control Duties and Responsibilities | 2-1 | 2-1 |
| Command Relationships | 2-2 | 2-7 |
| IPB Process | 2-3 | 2-7 |
| Command and Control Process | 2-4 | 2-9 |
| Command Posts | 2-5 | 2-12 |
| Command Communications Systems | 2-6 | 2-14 |
| Communications | 2-7 | 2-18 |
| OPSEC | 2-8 | 2-18 |
| Chapter 3 EMPLOYMENT | | |
| <u>Section I. Organization and Roles</u> | | |
| Organization | 3-1 | 3-1 |
| Roles and Responsibilities | 3-2 | 3-6 |
| <u>Section II. Terms and Missions</u> | | |
| Operational Terms | 3-3 | 3-9 |
| Employment Methods | 3-4 | 3-14 |

DISTRIBUTION RESTRICTION: Approved for public release; .distribution is unlimited.

*This publication supersedes FM 1-112, 21 February 1991.

| | Paragraph | Page |
|---|------------------|-------------|
| <u>Section III. Environmental Considerations</u> | | |
| Environmental Factors | 3-5 | 3-17 |
| <u>Section IV. Movement to the Objective Area</u> | | |
| Preparation For Movement | 3-6 | 3-24 |
| Movement | 3-7 | 3-28 |
| Occupation of the BP/SBF Position and ABF Position | 3-8 | 3-41 |
| <u>Section V. Objective Area Overview</u> | | |
| EA Planning | 3-9 | 3-44 |
| Principles of Direct Fire | 3-10 | 3-45 |
| Principles of Fire Control | 3-11 | 3-46 |
| <u>Section VI. EA Development</u> | | |
| Step 1. IPB | 3-12 | 3-48 |
| Step 2. Select the Ground for the Attack | 3-13 | 3-49 |
| Step 3. Integration of the EA | 3-14 | 3-50 |
| <u>Section VII. Direct Fire Planning</u> | | |
| Step 4. Planning the Direct Fire Fight | 3-15 | 3-55 |
| Step 5. Fire Commands | 3-16 | 3-56 |
| Step 6. Reviewing the Plan | 3-17 | 3-61 |
| Step 7. Rehearsing the Plan | 3-18 | 3-62 |
| Step 8. Executing the Plan | 3-19 | 3-62 |
| EA Development/Direct Fire Summary | 3-20 | 3-63 |
| <u>Section VIII. Completing the Engagement</u> | | |
| Breaking Contact | 3-21 | 3-64 |
| Egress Operations | 3-22 | 3-66 |
| Restoration | 3-23 | 3-67 |
| <u>Section IX. Other Operations</u> | | |
| Reconnaissance and Security | 3-24 | 3-68 |
| JAAT | 3-25 | 3-71 |

| | Paragraph | Page |
|--------------------|--|-------------|
| Chapter 4 | COMBAT SUPPORT | |
| | Fire Support | 4-1 4-1 |
| | IEW Operations | 4-2 4-12 |
| | AD | 4-3 4-14 |
| | Engineer Support | 4-4 4-19 |
| | NBC Support | 4-5 4-19 |
| Chapter 5 | COMBAT SERVICE SUPPORT | |
| | Planning and Coordination | 5-1 5-1 |
| | Fuel and Ammunition Requirements | 5-2 5-2 |
| | FARPs | 5-3 5-2 |
| | Vehicle and GSE Maintenance | 5-4 5-2 |
| | Aircraft Support | 5-5 5-2 |
| | Transportation Requirements | 5-6 5-5 |
| | Personnel Services | 5-7 5-5 |
| | Field Services | 5-8 5-7 |
| Chapter 6 | STABILITY AND SUPPORT OPERATIONS | |
| | Operational Concept | 6-1 6-1 |
| | Principles of SASO | 6-2 6-1 |
| | Employment Guidelines | 6-3 6-1 |
| | Types of Operations | 6-4 6-2 |
| | Lessons Learned | 6-5 6-3 |
| Appendix A. | ATTACK AIRCRAFT CHARACTERISTICS | A-1 |
| Appendix B. | AIR ASSAULT SECURITY | B-1 |
| Appendix C. | SAMPLE ORDER AND MISSION BRIEFING FORMATS | C-1 |
| Appendix D. | UNIT MOVEMENT | D-1 |
| Appendix E. | TACTICAL STANDING OPERATING PROCEDURES | E-1 |
| Appendix F. | AIR COMBAT | F-1 |
| Appendix G. | ASSEMBLY AREA OPERATIONS | G-1 |

FM 1-112

| | | |
|--------------------|--|---------------------|
| Appendix H. | DEEP OPERATIONS BY KIOWA WARRIOR ATTACK HELICOPTER BATTALIONS | H-1 |
| APPENDIX I. | THEATER MISSILE DEFENSE--SEARCH AND ATTACK | I-1 |
| Glossary | | Glossary-1 |
| References | | References-1 |
| Index | | Index-1 |

PREFACE

This manual is the Army's doctrinal manual for attack helicopter operations. It is designed to assist attack helicopter commanders, their staffs, and subordinate company commanders in the conduct of training and combat operations. It also serves as a guide for corps, division, and brigade commanders and their staffs. This manual discusses the organization, capabilities, and employment of attack helicopter units.

This manual incorporates current Army doctrine based on FM 100-5. It describes the ARI force structure and the associated TTP based on currently fielded systems. It is recognized that the fielding of the Army's planned digital information systems and modern aircraft, such as the AH-64D, will alter the TTP in this manual. During this transition to the future, lessons learned, equipment upgrades, and digital TTP will be captured and incorporated into the next edition of this manual.

This manual sets forth doctrinal principles that guide the conduct of light and heavy attack helicopter operations. It addresses specific TTP to clarify or emphasize these principles. Users must apply this doctrine within the capabilities and limitations of their units and develop SOPs that address specific techniques and procedures.

The proponent of this publication is HQ TRADOC. Send comments and recommendations on DA Form 2028 (Recommended Changes to Publications and Blank Forms) to the Commander, United States Army Aviation Center and Fort Rucker, ATTN: ATZQ-TDS-D (FM 1-112), Fort Rucker, AL 36362-5092.

Unless stated otherwise, masculine nouns and pronouns do not refer exclusively to men.

This publication has been reviewed for OPSEC considerations.

FM 1-112

This publication implements the following international agreements:

| | |
|--|---|
| STANAG 2019 (Edition Three) and QSTAG 509 | Military Symbols for Land Based Systems--APP-6 |
| STANAG 2041 (Edition Four) and QSTAG 520 | Operations Orders, Tables and Graphics for Road Movement |
| STANAG 2404 | Joint Anti-Armor Operations (Draft) |
| STANAG 2868 (Edition Four) | Land Force Tactical Doctrine-- ATP-35(A) |
| STANAG 2889 (Edition Three) and QSTAG 742 | Marking of Hazardous Areas and Routes Through Them |
| STANAG 2999 (Edition One) | Use of Helicopters in Land Operations--ATP-49 |
| STANAG 3497 (Edition One) | Aeromedical Training of Aircrew in Aircrew NBC Equipment and Procedures |
| QSTAG 277 (Edition Three) | Procedures for the Employment of Helicopters in the Antiarmor Role |

CHAPTER 1

ATTACK HELICOPTER FUNDAMENTALS

Attack helicopter battalions are assigned to divisional aviation brigades and corps ATKHRs (in corps aviation brigades). They provide the supported commander a highly mobile and lethal armor, personnel, and materiel destruction capability during the day and night. This chapter explains what an ATKHB is, how it is organized for the different types of divisions and the corps ATKHRs, and its organizational capabilities and limitations.

1-1. ROLES OF THE ATKHB

a. General.

(1) The ATKHB is an aerial maneuver unit usually employed as a battalion. It conducts attack, reconnaissance, and security operations that complement other maneuver forces. The ATKHB enables the supported commander to mass combat power rapidly at the decisive time and place to affect a battle's outcome. The commander must integrate the ATKHB into his tactical maneuver plan with other maneuver units. When employed with other combat assets, the ATKHB can strike the enemy where and when it is most vulnerable.

(2) An ATKHB never fights alone. Attacks are coordinated with other maneuver, combat support, CSS, and joint forces to form a combined arms team. This team surprises and overwhelms the enemy at the point of attack. Attacks may be conducted out of physical contact with other friendly forces but synchronized with their scheme of maneuver, or they may be in direct contact with friendly forces.

b. Tenets of Army Operations. Success on future battlefields depends on how well the tenets of Army operations doctrine are applied. These tenets are initiative, depth, agility, synchronization, and versatility. General aviation employment principles as related to these tenets are discussed in depth in FM 1-111, Aviation Brigade Operations, Chapter 1. Application of these tenets as related to the ATKHB are discussed below.

(1) Initiative. Attack helicopters are offensive weapon systems. They provide commanders the means to deliver massed firepower rapidly and accurately, thus disorganizing enemy forces and allowing the friendly force to gain or maintain the initiative. To be successful, the ATKHB must be integrated into the ground commander's scheme of maneuver. This requires that commanders analyze the battlefield and decide early where the ATKHB will be employed.

(2) **Depth.** The ATKHB can attack the enemy forces anywhere on the battlefield. Commanders must see and use the entire battlefield to strike the enemy and prevent it from concentrating forces at a point of its choice. The speed with which attack helicopters can mass combat power at chosen points in the battle area allows the force commander to influence the battle to a depth that would otherwise be beyond his reach.

(3) **Agility.** The mobility and flexibility of attack helicopters expand the reach of commanders to all areas of the battlefield. Terrain provides cover and concealment for attack helicopters just as it does for armor and infantry; however, it does not limit the mobility of the helicopter. The ATKHB can attack the enemy's flanks and rear, thus providing ground forces the time to maneuver and engage enemy forces from directions where they are most vulnerable.

(4) **Synchronization.** To survive and succeed on the battlefield, the ATKHB must fight as an integrated member of the combined arms team. In combat, the fires of other attacking weapons enhance the firepower of the attack helicopter. This combined attack strengthens the total force by overcoming limitations found in each weapon system. As a result, total combat power is increased and survivability is improved. When the enemy is simultaneously faced with an array of armor, infantry, FA, TACAIR, and attack helicopter units, it can no longer concentrate on countering a single set of weapons from one direction at a time. Rather, it is attacked throughout its depth with a variety of weapons.

(5) **Versatility.** On today's and tomorrow's battlefields, the tempo of the fight is rapid, violent, and extremely fluid. The ATKHB's primary mission is the destruction of enemy armor or mechanized forces. The ATKHB, however, must be prepared to conduct reconnaissance and security operations. Additionally, in OOTW, a subversive or less distinguishable enemy may require the ATKHB to provide direct or indirect fires in DS of friendly ground forces operating in an urban environment. The ability of the ATKHB to transition smoothly and rapidly is the result of well-led, well-trained, and well-equipped forces; high standards; and detailed planning. While the ATKHB can react quickly, it requires as much mission planning time as other maneuver battalions.

c. **Framework of the Battlefield.** The Army's warfighting doctrine specifies that deep, close, and rear operations occur simultaneously. An ATKHB can conduct all three during offensive and defensive operations. An ATKHB conducting deep operations allows corps and division commanders to influence close operations before the enemy closes with friendly forces. During the conduct of close operations, an ATKHB allows corps and division commanders to weigh their main effort and brigade commanders to attack the enemy in depth. An ATKHB also gives corps and division commanders the ability to mass combat power rapidly against enemy ground penetrations and large air-borne or heliborne assaults into the corps or divisional rear area.

d. Attack Helicopters in Combat Operations. The force commander's assessment of the factors of METT-T influence the missions that are assigned to the ATKHB. With the ATKHB commander's assistance, the force commander determines where the ATKHB will be used. From the force commander's mission and intent, the ATKHB commander determines how the battalion will be employed. Some of the force commander's options for employing the ATKHB are--

- (1) To attack massed armored or light forces.
- (2) To attack in depth to extend the influence of the force.
- (3) To dominate avenues of approach.
- (4) To reinforce ground forces by fire.
- (5) To mass to defeat enemy penetrations.
- (6) To attack to protect the flanks of a moving or halted friendly main body.
- (7) To provide security for the movement and passage of lines by ground forces.
- (8) To conduct reconnaissance.
- (9) To perform search and attack missions.

e. Role in the Offense.

(1) Destroying the enemy's fighting force is the only sure way of winning any future conflict. The operational concepts of offensive operations are concentration, surprise, speed, flexibility, and audacity. The ATKHB gives the maneuver commander, who conducts offensive operations, a viable force that can rapidly concentrate firepower at the decisive time and place.

(2) Corps and divisions use five complementary elements in fighting offensive battles. These elements are--

- (a) Main and supporting attacks.
- (b) A reserve in support of an attack.
- (c) Reconnaissance and security operations forward, to the flanks, and to the rear of attacks.
- (d) Deep operations.

(e) Rear operations.

(3) ATKHBs can operate as part of each of these elements by conducting attacks, reconnaissance, and security operations. As part of the five elements, they can act as part of the main attack force by conducting deliberate attacks. The ATKHB can also conduct supporting attacks by cutting off enemy reinforcements and acting as part of the reserves, ready to weigh the main effort and to exploit success.

f. **Forms of the Offense.**

(1) **Movement to contact.** A movement to contact is used to gain or reestablish contact with the enemy. It may be used when contact with the enemy has been temporarily lost, or it may be used to initiate an attack. A movement to contact helps develop the situation and maintain the commander's freedom of action. During a movement to contact, the ATKHB operates with ground forces and is critical to the success of the advance forces and the main body. A movement to contact often results in a meeting engagement; that is, forces engage each other by chance rather than by design. As part of the covering force or advance guard, the ATKHB can destroy forward enemy elements identified by reconnaissance, air cavalry or ground forces. The mobility and fire-power of the ATKHB will permit the main body commander to overwhelm the enemy and maintain the initiative. This means that the commander will not have to pause and marshal the necessary ground combat power to attack.

(a) As part of the advance guard, the ATKHB is used to attack enemy forces that are attempting to disrupt friendly operations. The ATKHB will operate from successive FAAs located along the axis of advance. As lucrative targets of opportunity are identified by other members of the advance guard, the ATKHB maneuvers to conduct hasty attacks to destroy or disrupt them. The battalion plans these hasty attacks using the IPB process. The ATKHB may also perform search and attack missions during a movement to contact. This technique is used when the enemy situation is vague and the area of operations is large.

(b) When the ATKHB is employed as part of the main body, it will exploit enemy weaknesses and attack counter-attacking forces, and operate from successive FAAs. The ATKHB then will maneuver to reinforce attacking ground forces or attack advancing or withdrawing enemy forces.

(c) When planning to operate as part of a movement to contact, the ATKHB commander looks at possible EAs along the entire axis of advance and their associated holding areas, attack routes, and attack by fire positions.

(2) **Attack.** The two types of attacks for attack helicopters are the hasty attack and the deliberate attack. Each is discussed in the paragraphs that follow.

(a) **Hasty attack.** A hasty attack is an operation for which a unit has not made extensive preparations. It is conducted with the resources immediately

available to maintain momentum or take advantage of the enemy situation. Hasty attacks are normally conducted as a branch to a deliberate attack or a reconnaissance or security operation. For attack helicopters, a hasty attack is made on an enemy force to retain the momentum of the entire force. Hasty attacks conducted by the ATKHB are made with the foreknowledge of where the EAs and battle positions are located. The exact time, EA, and the threat to be encountered during the attack, however, are not known until shortly before the mission.

(b) Deliberate attack. A deliberate attack is conducted against an enemy that is well-organized and cannot be turned or bypassed. It is planned and carefully coordinated with all concerned elements. The deliberate attack is based on a thorough reconnaissance, an evaluation of all available intelligence and relative combat strength, an analysis of various courses of action, and other factors affecting the situation. To conduct a successful deliberate attack, the ATKHB is integrated with the overall force scheme of maneuver. The ATKHB provides a mobile and flexible combat capability and can execute contingency plans as well as attacks that support the main effort. During a deliberate attack, the ATKHB can conduct attacks on enemy C² facilities and on counterattacking or withdrawing enemy forces.

(3) Exploitation. An exploitation usually follows a successful attack and is made to take advantage of weakened or collapsed enemy defenses. It prevents the enemy from reorganizing a defensive system or conducting an orderly withdrawal. An exploitation also is conducted to secure deep objectives. During an exploitation, an ATKHB is employed as part of a larger force. The ATKHB strikes the enemy's flanks and rear areas disrupting its withdrawal and attempts to reorganize. The ATKHB operates as in a movement to contact by following the ground forces and is prepared to conduct hasty attacks on counterattacking and withdrawing enemy forces. The ATKHB can also conduct deep attacks to further disrupt the enemy.

(4) Pursuit. A pursuit is an offensive operation taken after a successful attack or developed during an exploitation. The pursuit takes advantage of enemy weaknesses and its inability to establish an organized defense. As the enemy attempts to disengage, friendly forces maintain relentless pressure in an attempt to destroy enemy forces completely. A pursuit requires unrelenting pressure, speed, mobility, and firepower to complete the enemy's destruction. The ATKHB is an essential element in the pursuit. As ground forces attempt to maintain contact and flank the enemy, the ATKHB and air assault forces can maneuver deep to cut off the enemy as it attempts to withdraw. The ATKHB and air assault forces also can block entry to relieving enemy forces and can attack retreating enemy forces, which further deteriorates their situation. Repeated attacks by the ATKHB will quicken the disintegration of enemy forces and will destroy their will to fight. C² during a pursuit is critical. Commanders must coordinate the pursuit by ground forces and the ATKHB to ensure success during a rapidly changing combat environment. Communications may become difficult or be broken. When this occurs, commanders must act quickly to reestablish communications and ensure coordination between air and ground maneuvers.

g. Forms of the Defense.

(1) A successful defense requires active and passive elements working together to regain the initiative. The objective of a defensive operation is to cause the enemy attack to fail; preserve the force, facilities, and installations; control key terrain; gain time; or concentrate forces elsewhere. Other objectives may be to retain captured terrain and degrade enemy forces so that offensive operations can be resumed. Successful defensive operations depend on--

(a) Synchronizing all available combat capabilities.

(b) Seizing the tactical initiative locally and then generally as the entire force shifts from defense to offense.

(c) Fighting the enemy throughout the depth of its formations to delay and disorganize it and create opportunities for offensive actions.

(2) The ATKHB normally participates in two types of defense--the mobile defense and the area defense. The ATKHB uses its mobility and long range observation and engagement capabilities to deny terrain to the enemy, as well as support the ground defense with direct fires.

(a) **Area defense.** ATKHBs normally conduct an area defense when directed to defend specified terrain, when the enemy enjoys a mobility advantage over the defending force, when well-defined avenues of approach exist, and the defending force has sufficient combat power to cover the likely enemy avenues of approach in sector. The orientation of the area defense is to deny the enemy designated terrain. Maneuver within an area defense usually consists of repositioning between defensive positions or within sectors and counterattacks. A perimeter defense is a form of area defense, oriented in all directions.

(b) **Mobile defense.** ATKHBs conduct a mobile defense by allowing the enemy force to advance to a point where it is exposed to a decisive attack by a striking force. The end state of the mobile defense is destruction of the enemy force. The commander conducts a mobile defense by organizing his force into two subunits: a fixing force and a striking force. The fixing force shapes the penetration or contains the enemy advance, while the striking force conducts the decisive attack.

h. Deep Operations.

(1) Deep operations, or raids, are activities directed against enemy forces that currently are not engaged but that could influence division or corps close operations within the next 24 to 72 hours. The ATKHB will conduct deep operations at corps and divisional levels. Deep attacks by corps ATKHBs help the corps commander to shape the battlefield and set the terms for close operations. Deep attacks conducted by divisional ATKHBs help the division commander to shape the battlefield and are used to allow

defending maneuver brigades to engage the enemy throughout its depth. Deep operations will occur during both friendly offensive and defensive operations.

(2) Deep operations are high-risk, high-payoff operations that must be executed with the utmost care. Planning and IPB must be detailed and as precise as possible to allow the ATKHB to accomplish its mission with the least amount of risk. The ATKHB itself is a high value/high payoff target (HVT/HPT). To send it deep requires the recognition that the target is worth the expenditure of the ATKHB and the combat support elements that it takes to accomplish the mission.

i. Close Operations.

(1) The ATKHB may be part of the larger force's security operation as a member of a covering force. The ATKHB is the primary force that ensures that the covering force commander can retain the spirit of the offense. Because of the speed and flexibility of the ATKHB, it can rapidly concentrate combat power throughout the covering force area. The ATKHB attacks to accomplish the objectives of the covering force commander. Employed well forward, it operates out of FAAs in the rear of the covering force area. At corps level, the ATKHB may be attached or placed under the OPCON of armored cavalry regiments to increase their long-range antiarmor fires. At divisional level, the ATKHB is the primary long-range armor killer.

(2) Once the fight has moved into the main battle area, the commander should use the ATKHB against the enemy's main effort. To take decisive offensive action, supported commanders can retain their ATKHBs as part of their reserve. An ATKHB should not be held in reserve to redeem failure. The commander commits the ATKHB at a decisive place to exploit success or ensure accomplishment of the mission. Using an ATKHB during the defense often comes as part of a counterattack. The ATKHB counterattacks along with other maneuver forces to strike the enemy throughout the depth of the battlefield and help the force seize the initiative.

(a) Attacking enemy second echelon battalions and regiments.

While ground units engage the enemy from battle positions where they can range the leading elements of the enemy attack, the ATKHB maneuvers to attack the enemy's follow-on battalions and regiments simultaneously. Thus they attack the enemy throughout its depth.

(b) Massing to defeat enemy penetrations. ATKHBs attack enemy penetrations along with other maneuver forces to defeat them and restore the FLOT. While other maneuver forces attack the head of the penetration, the ATKHB attacks the penetration in depth, denying the enemy commander the opportunity to mass, bypass, or withdraw. Once the enemy is encircled, the ATKHB can attack enemy breakouts or any other forces that may attempt to relieve the encircled enemy force.

(c) Attacking to defeat enemy flanking forces. The ATKHB can be used to dominate avenues of approach into the rear and flanks of friendly forces. The

FM 1-112

ATKHB will reinforce the flank screen or guard to defeat the threat to the flanks of the main body.

j. Rear Operations.

(1) Rear operations are conducted to assure freedom of maneuver and operational continuity from the corps rear boundary forward to the rear boundaries of committed maneuver units. ATKHBs, along with ground forces, may be given on-order missions to act as rapid reaction forces for Level II or III incursions into brigade, division, or corps rear areas. The ATKHB can rapidly react to enemy heliborne or airborne operations into the friendly force's rear area. The ATKHB should attempt to attack the enemy force in its assembly area or just as it arrives in its LZ. The ATKHB is especially valuable in rear operations when the enemy has air-landed or air-dropped light armored vehicles.

(2) Once the enemy force has dispersed, the ATKHB becomes less effective in the fight. Major mechanized incursions into the rear area are attacked in the same manner as they are during close or deep operations. The ATKHB attacks until the force commander can respond with additional forces to defeat the penetration. During rear operations, coordination between artillery, ADA, CAS, and ATKHBs must be accomplished by liaison officers working in the divisional and corps rear operations cell of the rear command post.

(3) Care must be taken to ensure the targets the ATKHB will attack are positively identified. Rear area commanders must coordinate closely with the supporting ATKHB to identify the locations of the enemy forces and provide control measures to deconflict friendly fires. Target handovers to elements of the ATKHB should be made by friendly forces in contact with the enemy.

1-2. ORGANIZATION

a. Heavy Division. The aviation restructure initiative allocates two ATKHBs per heavy division, one active duty and one Reserve or National Guard. Each battalion is pure AH-64 or AH-1, equipped with 24 attack helicopters in three companies of eight each. The battalion also includes a HHC and AVUM company. (See Figure 1-1).

(1) The HHC provides C², logistics support, and ground maintenance support for the battalion. The headquarters section consists of the battalion commander, his staff, and staff sections. The HHC consists of a company headquarters, a supply section, an automotive maintenance section, a mess section, a battalion communications section, a medical treatment section, and a Class III/V platoon. To exercise C² during the mission, the battalion commander (or S3) may fly an AH-64, fly in the back of a UH-60, or C² from a ground TAC. The aviation brigade general support

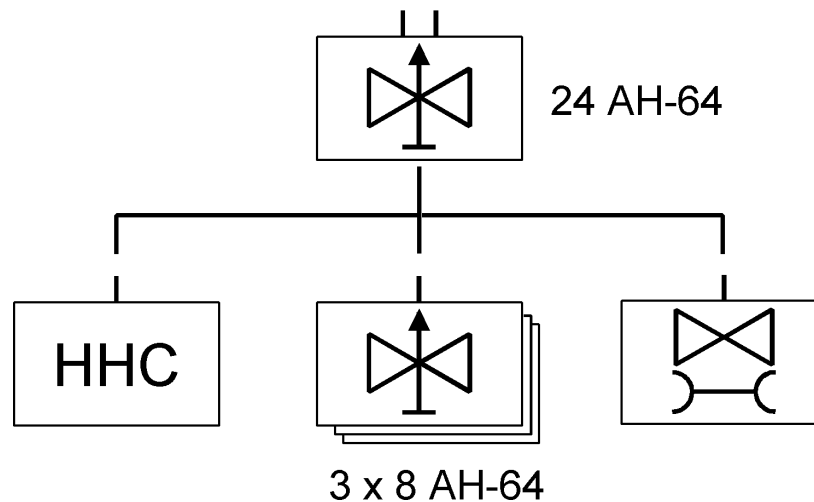

Figure 1-1. Heavy division ATKHB

aviation battalion will provide utility aircraft for the ATKHB's C², CS, CSS, and combat search and rescue requirements as directed by the brigade commander.

(2) The AVUM company provides unit-level maintenance for battalion aircraft. The company consists of a company headquarters, a quality assurance section, an aircraft maintenance section, and an aircraft component repair section.

(3) The three ATKHCs provide the ATKHB with an antiarmor, antipersonnel and antimateriel capability. Each company consists of a headquarters section, a scout platoon with three aircraft, and an attack platoon with five aircraft. The commander may task organize his company as he sees fit to accomplish the mission. With eight aircraft per ATKHC, commanders should plan for six aircraft available (75-percent FMC rate) for missions. The two-ship "lead-wingman" team provides a high degree of task organization options, mission flexibility, and mutual support between teams. This also simplifies C² for the ATKHC commander by putting a platoon leader in each team while the company commander flies as a member of the third team, positioning himself as he sees fit to employ his company and fight the battle.

b. Light Division.

(1) The light division has one ATKHB organized the same as the heavy division (HHC, AVUM, and three ATKHCs) except the light division is equipped with OH-58D Kiowa Warriors or AH-1s. In the HHC, mess (Class I), fuel (Class III), and ammunition (Class V) are provided by the aviation brigade HHC. (See Figure 1-2).

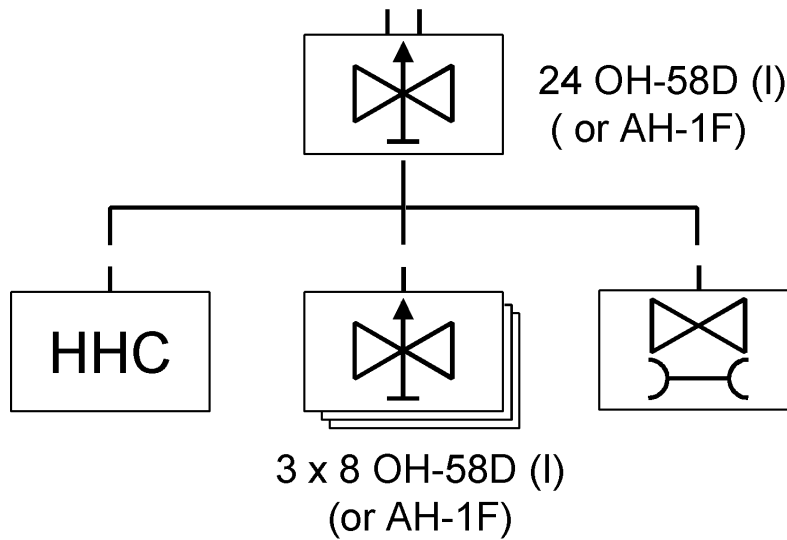

Figure 1-2. Light division ATKHB

(2) The brigade must support the aerial movement of all classes of supply since there are no utility aircraft in the ATKHB. C² issues are the same as in the heavy division. The aviation brigade's AHB will provide utility aircraft, C², CS, CSS, and CSAR for the ATKHB's requirements as directed by the brigade commander.

c. Air Assault Division.

(1) The air assault division is authorized three ATKHBs equipped with AH-64s. The battalion organization is the same as the heavy division (HHC, AVUM, and three attack companies). (See Figure 1-3).

(2) To exercise C² during the mission, the ATKHB commander (or S3) may fly an AH-64, fly in the back of a UH-60 or command from a ground TAC. The aviation brigade CAB will provide utility aircraft for the attack battalion's C², CS, CSS, and CSAR requirements as directed by the brigade commander.

d. Airborne Division.

(1) The airborne division has one ATKHB organized the same as the light division (HHC, AVUM, and three attack companies), equipped with OH-58D Kiowa Warriors. In the HHC, mess (Class I), fuel (Class III), and ammunition (Class V) are provided by the aviation brigade HHC. (See Figure 1-4).

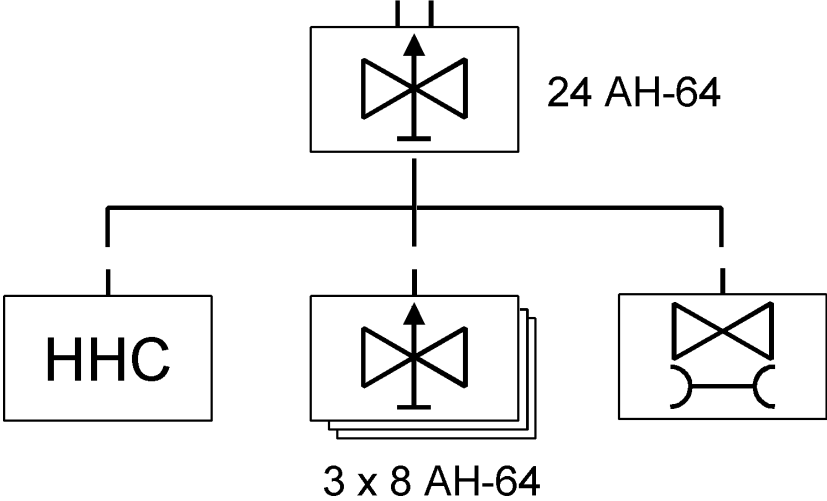

Figure 1-3. Air assault division ATKHB

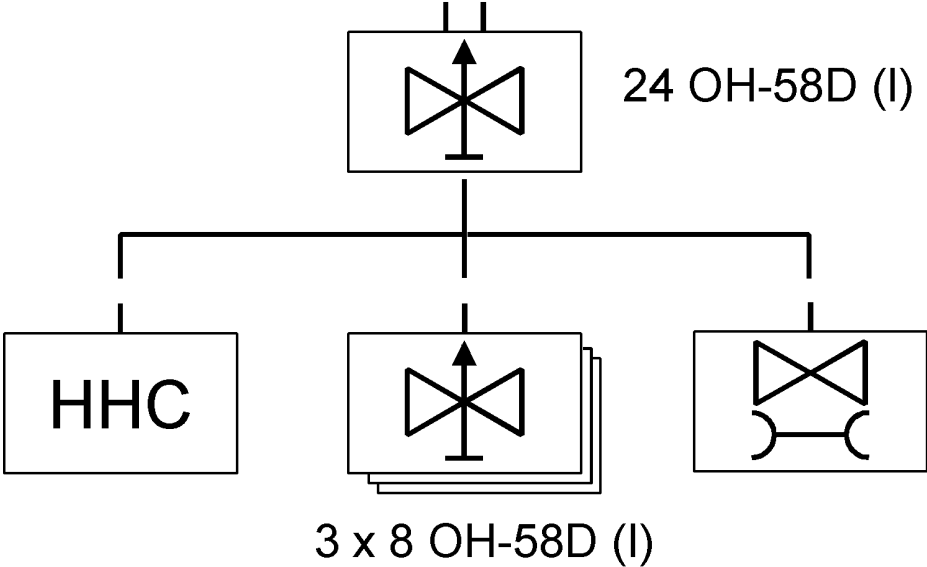

Figure 1-4. Airborne division ATKHB

(2) The brigade must support the aerial movement of all classes of supply since there are no utility aircraft in the ATKHB. C² issues are the same as in the heavy division. The aviation brigade's AHB will provide utility aircraft, C², CS, CSS, and CSAR for the ATKHB's requirements as directed by the brigade commander.

e. Corps Attack Regiment.

(1) The ATKHR of the corps aviation brigade is normally allocated three AH-64 equipped battalions. The battalion organization is the same as the heavy division (HHC, AVUM, and three attack companies). (See Figure 1-5).

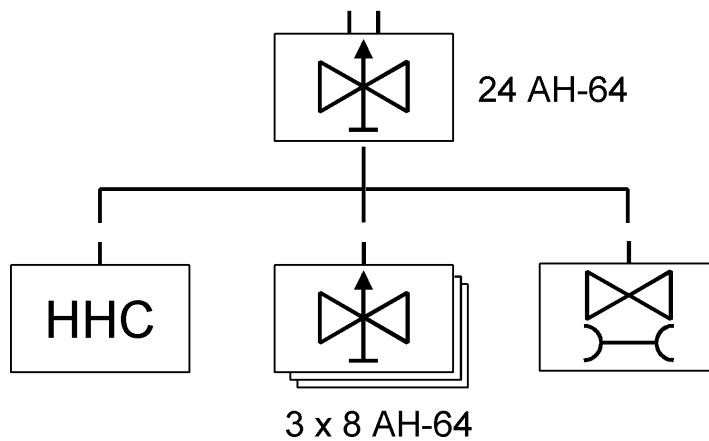

Figure 1-5. Corps ATKHB

(2) The brigade must support the aerial movement of all classes of supply since there are no utility aircraft in the ATKHB. C² issues are the same as in the heavy division. The aviation brigade's CAB will provide utility aircraft for the attack battalion's C² requirements while the combat support aviation battalion will provide utility aircraft for CS, CSS and CSAR.

1-3. MISSIONS, ORGANIZATIONAL CAPABILITIES, AND LIMITATIONS

a. Missions.

(1) The primary mission of an ATKHB is to destroy enemy forces using fire, maneuver, and shock effect. To accomplish this mission the ATKHB attacks the enemy to destroy, attrit, disrupt, or delay. It may also conduct other offensive operations, as well as reconnaissance, security, and defensive operations.

(2) The ATKHB is most effective against massed, moving targets and least effective against enemy forces in prepared, well-camouflaged positions. Without the support of ground maneuver forces, the ATKHB cannot conduct missions that require the occupation of terrain. They can, however, deny the enemy terrain for a limited time by dominating it with direct and indirect fires.

(3) The ATKHB mission is the same for all ATKHBs, regardless of the type of division or corps to which assigned. However, depending upon the type of division or level or assignment, employment criteria, mission priorities, and target priorities may vary greatly.

(4) The mission and the commander's intent specifies the mission success criteria. This criteria allows subordinate commanders to assess whether or not the mission has been accomplished at the completion of the engagement. An example of a mission statement is:

At 221700Z MAR 96, 1-112th ATKHB occupies FAA ROOSEVELT (QS 12341234). On order, attack to attrit the 25th TR in EA THUNDER (RS 987123, RS 123456, RS 234567, RS 567890) to delay the enemy's advance east of the Silver River crossing.

(5) The mission statement must include a concise "why" to fully define success. Given the wide variety of potential enemies and potential theaters of operations, the ATKHB commander must base his unit's mission statement and his intent's end state on a thorough IPB. Based on the IPB, the commander must also articulate an endstate that is understandable and can be quantified on the battlefield. For example, "of the 30 trucks identified in the convoy, 20 must be destroyed for mission success."

(6) The following are examples of the "what" in the ATKHBs mission statement. Included is the risk assumed by the ATKHB in accomplishing each attack mission. Also included is planning guidance for quantifying the attack mission statement's "why" and, based on the desired effect on the enemy, the end state portion of the commander's intent.

(a) **Attack to destroy.** This is a high-risk mission for the ATKHB. When given the mission to attack to destroy, the ATKHB uses direct and indirect fires to physically render an enemy force combat-ineffective unless it is reconstituted. The ATKHB must attack the enemy force with enough combat power to accomplish the mission and meet the commander's intent. To accomplish this mission, the ATKHB must accept a substantial risk that may cause it to become combat ineffective at the completion of the attack.

(b) **Attack to attrit.** This is a high- to medium-risk mission for the ATKHB. When given the mission to attack to attrit, the ATKHB uses direct and indirect fires to reduce the effectiveness of an enemy force caused by loss of personnel and materiel. The ATKHB must attack the enemy force with enough combat power to

FM 1-112

accomplish the mission and meet the commander's intent. The greater the enemy force that the ATKHB must attrit, the greater the risk the commander must accept.

(c) **Attack to delay.** This is a medium- to high-risk mission for the ATKHB. When given the mission to attack to delay, the ATKHB uses direct and indirect fires to engage the enemy, understanding that the destruction of the enemy force is secondary to slowing his advance to gain time. The ATKHB must attack the enemy force with enough combat power to accomplish the mission and meet the commander's intent. The ATKHB attacks to delay the enemy's use of a geographic area (maneuver corridor, river crossing site) for a specific period of time. The risk that the battalion accepts is determined by the amount of time that the ATKHB must delay, location of the enemy, and the enemy force that is encountered.

(d) **Attack to disrupt.** This is a medium- to low-risk mission for the ATKHB. When given the mission to attack to disrupt, the ATKHB uses direct and indirect fires to break apart an enemy's formation and tempo, interrupt the enemy's time table, cause premature commitment of forces, and/or piecemeal their attack. The ATKHB must attack the enemy force with enough combat power to achieve the desired results with one mass attack or sustain the attack until the desired results are achieved. The commander sets the amount of risk based on the friendly loss he is willing to accept, the location of the attack, or the number of attacks that will be made.

NOTE: These attack criteria also apply to mission statements issued for other offensive operations (exploitations, pursuits, or counterattacks). To the ATKHB, these missions will most likely be conducted as attack missions, with the operation not specifically referred to by name.

(e) **Conduct reconnaissance.** The ATKHB may be tasked to conduct reconnaissance operations (zone, route, area, force oriented, or RIF). More information on reconnaissance operations may be found in Chapter 3 and FMs 1-114 and 17-95.

(f) **Provide security.** The ATKHB provides security to friendly forces as they conduct passages of lines, river crossings, air assaults, and as they maneuver in a movement to contact. The types of security it may provide are screen, guard, cover (if augmented), area security, and air assault security (a form of guard). It will position itself where it can make a hasty attack to assist friendly forces to disengage or brush aside enemy forces attempting to disrupt the operation. More information on security operations may be found in Chapter 3 and FMs 1-114 and 17-95.

(g) **Defend.** The ATKHB may be tasked to conduct an area or mobile defense in coordination with a ground force. The ATKHB will control its assets to force the enemy to attack under unfavorable circumstances and retain decisive terrain or deny a vital area to the enemy. More information on defensive operations may be found in Chapter 3 and FM 17-95.

(7) Figure 1-6 shows the operations and their forms that the ATKHB may perform.

b. Capabilities. The ATKHB and other aviation assets dominate the third dimension of the battlespace. This provides an invaluable maneuver capability to the ground force commander. The capabilities of an ATKHB are as follows:

(1) **Mobility.** The ATKHB fully exploits the vertical dimension of the battlefield. Aggressive terrain flight techniques allow the commander to rapidly place the ATKHB at the decisive place at the optimum time. Typically, the area of operations for an ATKHB is the entire corps or divisional sector.

(2) **Speed.** Attack helicopters move across the battlefield at speeds in excess of 3 kilometers per minute. Although METT-T dependent, typical planning airspeeds are 100 to 120 knots during daylight and 80 to 100 knots at night. Speeds during marginal weather are reduced commensurate with prevailing conditions.

(3) **Range.** The ATKHB can attack targets up to 150 km across the FLOT. If greater depth is required, the addition of ERFs tanks can further extend the AH-64's range with a corresponding reduction in Hellfire missile carrying capacity (four fewer Hellfire missiles for each ERFs tank installed).

(4) **Versatility.** Under the ARI, the firepower available to the force commander is increased but the employment concepts of the ATKHB remain the same. In a pure attack helicopter ATKHB, the traditional scout and attack missions are no longer aircraft dependent. During the combat decision making process, the ATKHC commander task organizes his assets and designates specific aircraft mission responsibilities based on METT-T. He has the flexibility to maintain the traditional scout-weapon team employment concept or focus his assets as a pure attack force. The dual role of the airframe, coupled with the cross training of the attack helicopter crew provide the force commander, the ATKHB commander and the ATKHC commander a combat force which is diverse and can meet the mission requirements in any environment, day or night, with advanced forward looking infrared and night vision systems.

(5) **Lethality.** Commanders may vary the weapons carried on attack helicopters to meet specific mission requirements. The AH-64 Apache, OH-58D Kiowa Warrior, and the AH-1 Cobra are each capable of carrying a variety of armament into combat for employment in day or night environments. As with any weapon system, the proper mix and mass of ammunition is critical for mission success. More information on attack helicopter capabilities may be found in Appendix A.

(a) **AH-64.** The AH-64 is capable of carrying up to 16 laser-guided Hellfire missiles, giving the battalion the capability to engage a total of 288 enemy targets at ranges of up to 8 km. The AH-64 also can carry up to 1,200 rounds of 30 mm for the

FM 1-112

| OPERATION | FORM | DESCRIPTION |
|-----------------------|----------------------|--|
| OFFENSE | ATTACK | An offensive operation characterized by movement supported by fire. The purpose is to destroy, delay, disrupt, or attrit the enemy. |
| | - HASTY ATTACK | An offensive operation in which preparation time is traded for speed to exploit an opportunity. |
| | - DELIBERATE ATTACK | An offensive action characterized by preplanned coordinated, employment of fires, and movement to close with and destroy the enemy. |
| | - RAID | An operation involving swift penetration of hostile territory to secure information, confuse the enemy, or destroy installations or forces. |
| | MOVEMENT TO CONTACT | Used to develop the situation, establish, or regain contact with the enemy. |
| | PURSUIT | An offensive action against a retreating enemy force. |
| | EXPLOITATION | The following-up of gains to take full advantage of success in battle. |
| DEFENSE | MOBILE | Orients on the defeat or destruction of the enemy force by allowing it to advance to a point where it is exposed to a decisive attack by a striking force. |
| | AREA | Orients on denying the enemy designated terrain. Conducted to defend specified terrain, when the enemy enjoys a mobility advantage over the defending force, when well-defined avenues of approach exist, and the defending force has sufficient combat power to cover the likely enemy avenues of approach in sector. |
| RECONNAISSANCE | ZONE | A directed effort to obtain detailed information concerning all routes, obstacles, terrain, and enemy forces within a zone defined by boundaries. |
| | AREA | A directed effort to obtain detailed information concerning the terrain or enemy activity within a prescribed area such as a ridge line, woods, or other feature. |
| | ROUTE | A directed effort to obtain detailed information of a specified route. |
| | RECON IN FORCE | Conducted when commanders cannot obtain adequate intelligence by other means. An aggressive form of reconnaissance. |
| SECURITY | SCREEN | A form of security that provides early warning. |
| | COVER | A covering force operates independent of the main body to deceive, disorganize, and engage the enemy. The cover may operate forward, behind, or on the flanks of the main body. |
| | GUARD | A form of security in which a unit is tasked to protect the main body by preventing the enemy from being able to engage main body forces with direct fire weapons. |
| | AREA | Conducted when a force is given the mission to secure a specific area. Convoy and route security are applications of area security. |
| | AIR ASSAULT SECURITY | A form of guard unique to aviation. Conducted during air assault operations to protect the assaulting force. |
| RETROGRADE | DELAY | Mission that trades space for time while retaining flexibility and freedom of action. |
| | WITHDRAWAL | A planned, voluntary disengagement that anticipates enemy interference. |

Figure 1-6. Operations and their forms for the ATKHB

destruction of thin-skinned and air defense targets at ranges of up to 3,000 meters. Each of the four Hellfire missile racks may be replaced with 7 or 19 shot, 2.75-inch rocket pods.

(b) **OH-58D (I)**. The OH-58D (I) Kiowa Warrior is capable of carrying up to 4 Hellfire missiles. It can carry a .50 caliber machine gun and 500 rounds of ammunition on the left pylon for self-protection or anti-personnel operations. It can carry any combination of a 7-shot rocket pod, a 2-missile Hellfire launcher or a 2-missile air-to-air stinger launcher on either side of the aircraft.

(c) **AH-1F**. The AH-1 is capable of carrying up to 8 tube launched, optically tracked, wire guided missiles. The AH-1 also can carry up to 750 rounds of 20 mm for the destruction of thin-skinned and air defense targets at ranges of up to 2,000 meters. Each wing has two weapons hardpoints that may carry a 7 or 19 shot, 2.75-inch rocket pods each. Due to power limitations, the AH-1 must trade off fuel for ammunition. Planners must know and understand this limitation to capitalize on the effectiveness of the AH-1. In addition, the AH-1 is primarily a day-only weapon system. However, modified AH-1Fs equipped with C-NITE telescopic sight units can engage targets with TOW missiles and cannon during both daylight and darkness.

(6) Video reconnaissance.

(a) The video recorder systems on the AH-64 and OH-58D (I) provide near real-time intelligence on the terrain or enemy forces for commanders to use at critical decision points. This "birds-eye view" is an invaluable asset for current and future operations planning.

(b) Video recorder operations can be highly successful with prior planning. Units should develop an SOP for video recorder operations to assist in video reconnaissance and BDA. This SOP should include procedures explaining when to record (considering limited recording time), how to properly scan a target area, and how the crew narrates the tape during recording, keying on aircraft location and descriptions of the target.

c. Limitations.

(1) **General**. Time for planning is critical for every mission. If a unit receives a short-notice mission or a major change in the original mission then time must be allowed to plan and clear routes, and to brief aircrews. Follow-on units may be committed along different routes with other combat multipliers, but the same battalion should not be considered for reattack across the FLOT until resupplied and reequipped as necessary.

(2) **Weather**. Although fully capable of operating in marginal weather, attack helicopter capabilities are seriously degraded in conditions below a 500-foot ceiling and visibility less than 3 km. Because of the Hellfire missile's trajectory, ceilings below 500 feet require the attack aircraft to get too close to the intended target to avoid missile

FM 1-112

loss. Below 3 km visibility, the attack aircraft is vulnerable to enemy ADA systems. Except for C-NITE equipped aircraft, the AH-1 is not equipped with a night vision or target designation system for periods of darkness.

(3) CSS. Helicopters consume large amounts of fuel, ammunition, and repair parts and require a CSS distribution system across the entire battlefield. An ATKHB will normally employ two FARPs; one active for that specific mission, the other moving to or setting up in a new location for future operations. A FARP will normally have four refuel or rearm points. Planning time for a complete battalion turnaround is approximately two hours. Total time in the FARP is a factor of the amount of fuel and ammunition which is received by the aircraft. Depending on the situation, quicker turnarounds are feasible.

CHAPTER 2

BATTLE COMMAND

Command, control, and communications are the most significant and difficult portions of the employment of the ATKHB. FM 1-111 describes each of these concepts in detail. This chapter discusses the duties and responsibilities of the ATKHB commander and his staff, relevant command relationships, the C² process, the IPB process, command posts, and communications.

2-1. COMMAND AND CONTROL DUTIES AND RESPONSIBILITIES

a. Commander. The ATKHB commander is responsible for the overall success of attack helicopter operations. He receives the mission from higher headquarters, decides how battalion assets are to be used, and directs the execution of plans. The commander must position himself during both planning and execution phases to ensure the success of the mission. During mission execution, the commander will normally position himself forward with committed assets to ensure unity of effort in accomplishing the mission. Attack helicopter battalions perform a wide range of missions. The commander maintains control and directs the action by--

- (1) Issuing specific orders.
- (2) Allocating available resources to accomplish the tasks.
- (3) Issuing a concept to the staff that specifies and assigns essential tasks.
- (4) Developing an estimate based on METT-T.
- (5) Establishing standing operating procedures to ensure personnel accomplish routine tasks and operations.

b. Staff. Through the staff, the battalion commander must assess the continuous flow of information, make timely decisions, and issue concise orders. The primary function of the staff, therefore, is to present essential information to the commander with a recommendation so that he will be able to make the best decision. The staff must have the latitude and flexibility to make recommendations or decisions when appropriate in response to rapidly changing situations on the battlefield. The staff must also deal with routine matters associated with running the battalion so that the commander may remain focused on combat operations. FM 101-5 describes the general duties and responsibilities of each staff officer. Additional, specific duties and responsibilities of attack helicopter battalion staffs are discussed in the following paragraphs.

FM 1-112

(1) Executive officer. The executive officer is the principal assistant to the commander. Although the XO may assume command in the absence of the commander, he is not in the chain of command. As the coordinator and supervisor of the staff, the XO is responsible for the execution of staff tasks and for coordinating the staff's efforts. He ensures that the staff performs as a team and not as separate staff sections. The XO assigns responsibilities and issues the commander's decisions to the staff and subordinate commanders on the commander's behalf. The XO-staff relationship does not preclude the staff from working directly with the commander. However, a staff officer is obligated to inform the XO of instructions or requirements received from the commander. During the commander's absence, the XO represents him and directs actions according to the commander's policies. The XO must be prepared to assume command at any time. Additionally, the XO is normally responsible for controlling the main command post during the battle. This allows the XO to keep abreast of the current situation (should he have to move forward and take the battle) and move the ATKHCs and support assets in the AO to support the mission. He also ensures that coordination between the main CP, the TAC CP, and other subordinate CPs is maintained.

(2) S1. The S1 normally operates from the main CP. He is responsible for all matters and issues relating to personnel in the battalion. The S1 and S4 must cross-train to facilitate the conduct of continuous operations. The S1--

- (a)** Supervises postal services.
- (b)** Prepares the personnel estimate.
- (c)** Assesses and enhances unit morale.
- (d)** Administers the prisoner-of-war program.
- (e)** Determines individual replacement requirements.
- (f)** Plans and supervises the use of civilian labor.
- (g)** Monitors unit strength and estimates personnel losses.
- (h)** Coordinates the development of a health services plan.
- (i)** Plans and supervises logistic and administrative services.
- (j)** Coordinates religious, legal, finance, and public affairs services.
- (k)** Prepares and coordinates medical and casualty evacuation plans.

(3) S2. The S2 normally remains at the main CP where communication assets are available for coordinating surveillance and reconnaissance activities and updating the current situation. The S2--

- (a)** Provides weather information.
- (b)** Prepares intelligence training materials.
- (c)** Prepares analysis of the area of operations and area of influence.
- (d)** Computes enemy strength and determines the order of battle.
- (e)** Prepares intelligence and counterintelligence estimates.
- (f)** Develops the IPB, priority intelligence requests, and reconnaissance and surveillance plans.
- (g)** Is the primary battle tracker and forecaster of enemy intentions.
- (h)** Provides input into the brigade and division reconnaissance and surveillance collection plan.

(4) S3. The operations officer is the commander's principal assistant for coordinating and planning operations. He monitors current and future operations, ensuring essential combat assets are provided when and where required, and anticipates developing situations and missions. The S3 and his staff section must be constantly aware of the changing situation. They must be responsive to the directives of higher headquarters as well as to the needs of subordinate commanders. Specifically, the S3 must be closely tied into the S2 and S4 to remain updated on the intelligence and logistics situation. Depending upon mission execution, the S3 may locate forward with the commander or may position himself as required to facilitate C². Additionally, the S3 controls the TAC if employed. The S3--

- (a)** Maintains troop lists.
- (b)** Integrates fire support.
- (c)** Prepares operations estimates.
- (d)** Predicts the effects of NBC weapons.
- (e)** Establishes communications priorities.
- (f)** Coordinates and controls civil-military operations.

FM 1-112

(g) Coordinates and publishes operations plans, operations orders, and fragmentary orders .

(h) Selects the general locations of the main CP, TAC, and other subordinate CPs.

(i) Coordinates and supervises OPSEC and rear operations.

(j) Coordinates unit replacements, attachments, and detachments.

(k) Prepares tactical movement plan and supervises movement in concert with the XO and CSM.

(l) Plans and supervises electronic warfare activities and psychological operations.

(m) Monitors and controls battalion and company tactical operations.

(n) Develops and supervises training programs.

(o) Develops deception plans and requirements.

(p) Advises the commander on combat operations.

(5) **S4.** The S4 must thoroughly understand the commander's intent and initiate timely actions to support that intent. The S4 usually collocates with the S1 in the main CP. Depending on the succession of command, the S4 may assume the duties of the XO or S3. He must monitor the tactical situation closely to initiate timely resupply and direct support. His duties also entail providing the commander with information on all logistics matters. The S4 coordinates with the Brigade S4 on the status of equipment, supplies, and future requirements. The S4--

(a) Prepares logistics estimate.

(b) Recommends main supply routes.

(c) Maintains supply and maintenance status.

(d) Plans and controls administrative movements.

(e) Plans for supply and maintenance requirements.

(f) Plans for transportation requirements and services.

(g) Procures, receives, stores, and distributes supplies.

- (h) Establishes combat service support priorities with the S3.
- (i) Determines requirements for civilian labor for logistics support.
- (j) Collects and disposes of excess property, salvage, and captured material.
- (k) Designates lines of movement and locations of combat service support elements.
- (l) Prepares logistics orders, plans, annexes, and paragraph 4 of operations orders or operations plans.

(6) Liaison officer. Liaison with other maneuver units is vital to ensuring that the ATKHB is properly employed and synchronized into the battle. The ATKHB commander is the unit's most effective liaison officer. When the commander is not available, he must designate a liaison officer. This officer must understand the commander's intent, must be proficient in attack helicopter operations, must know the unit's capabilities and limitations, and must ensure that the following tasks are accomplished:

- (a) Know the status and availability of aircraft.
- (b) Advise the supported commander on all matters concerning the employment of attack helicopter assets.
- (c) Ensure proper integration of the battalion within the scheme of maneuver, recommending courses of action that are within the capabilities of the ATKHB.
- (d) Keep the ATKHB commander abreast of the current situation and any intelligence information that projects the enemy's likely courses of action.
- (e) Coordinate with the force army airspace command and control element on the status of tactical operations, the location and status of ATKHB assets, and all other information that effects the use of airspace.
- (f) Effectively represent the ATKHB commander.

(7) Command sergeant major. The CSM advises the battalion commander on matters concerning soldiers of the battalion. He is not an administrator, however, he must understand the administration, logistics, and operational requirements of the battalion. The CSM will focus on any function critical to the success of the operation. AR 600-20 and FM 101-5 describe specific duties of the CSM. The following duties are included:

FM 1-112

(a) Focuses on soldier and soldier support matters; may monitor unit morale.

(b) May act as liaison, lead advance or quartering parties, and monitor key defensive preparations.

(c) Assists the XO in coordinating the battalion CSS effort.

(d) Executes established policies and standards on performance, training, appearance, and conduct of enlisted personnel.

(e) Maintains communications and provides counsel and guidance to NCOs and other enlisted personnel.

(f) Performs other duties as assigned by the commander, such as reception of new soldiers, inspection of command activities, and president/member of NCO selection boards.

(8) Special staff. Special staff officers assist the battalion commander in professional, technical, and other functional areas. The specific number of special staff officers will vary with the TOE authorization and the commander's desires. Special staff officers are assigned to the HHC; however, some are representatives of organizations providing support to, or receiving support from, the attack helicopter battalion. FM 101-5 describes the duties and responsibilities of special staff in detail. In the attack helicopter battalion, the special staff may include--

- S3 (air).
- A²C² personnel.
- Communications personnel.
- Chemical officer.
- Safety officer.
- Chaplain.
- Flight surgeon.
- Fire support officer.
- Engineer officer.
- Air defense artillery officer.
- Forward air controller.

2-2. COMMAND RELATIONSHIPS

The command relationships of the ATKHB are organic, assigned, attached, and OPCON. ATKHBs are assigned to aviation brigades at division level and to corps ATKHRs or corps aviation brigades. When the mission dictates, an ATKHB may be attached to a unit that can support its logistics needs. The ATKHB will be placed under OPCON of the gaining unit when the battalion is to be used for a specific mission, the effective time of the relationship is short, or the gaining unit is unable to provide logistics support. Normally, control of the ATKHB remains with the aviation brigade or ATKHR and shifts to other brigades as an allocation of combat power by division and corps headquarters. When the mission is completed, the ATKHB returns to the control of its parent brigade or ATKHR. Table 2-1 shows the types of command relationships that can be established between an ATKHB and other units.

Table 2-1. Possible ATKHB command relationships

| GAINING UNIT | ORGANIC | ASSIGNED | ATTACHED | OPCON |
|-----------------------|---------|----------|----------|-------|
| Theater Army | No | No | Yes | Yes |
| Corps | Yes | No | Yes | Yes |
| Division | Yes | No | Yes | Yes |
| Aviation Brigade | Yes | Yes | Yes | Yes |
| Ground Brigade | No | No | No | Yes |
| ACR | No | No | Yes | Yes |
| ATKHR | Yes | Yes | Yes | Yes |
| Battalion/Squadron/TF | No | No | No | No |

2-3. IPB PROCESS

a. Definition. FM 34-130 defines IPB as a systematic, continuous process of analyzing the threat and environment in a specific geographic area. IPB is an essential part of staff planning designed to support staff estimates and military decision making. Applying the IPB process helps the commander selectively apply and maximize his combat power at critical points in time and space by--

- (1) Determining the threat's likely courses of action.
- (2) Describing the environment the friendly unit is operating within and the effects of the environment on the unit.

b. Doctrinal Principles. The doctrinal principles of IPB call for--

- (1) Evaluating the battlefield's effects on friendly and threat operations.
- (2) Determining the threat's possible courses of action and arranging them in order of probability of adoption.
- (3) Identifying assets the threat needs to make each COA successful (high value targets) and where they can be expected to appear on the battlefield (target areas of interest).
- (4) Identifying the activities, or lack thereof, and the locations where they will occur that will identify the COA the threat has adopted.

c. IPB Process. Each level of command provides its subordinate units with IPB support and products such as overlays, templates, and enemy estimates. Corps ATKHBs will use IPB products provided by corps, corps aviation brigade, and the ATKHR. Divisional ATKHBs use IPB products provided by corps, division, and the aviation brigade or ground maneuver brigade. Using these IPB products as a basis, the ATKHB S2 conducts an IPB. At each unit level, IPB is continuous and is assisted by the aviation mission planning system. The process consists of four steps that will be performed each time the IPB process is conducted. These four steps are as follows:

(1) **Define the battlefield environment.** In this step, the S2 identifies the characteristics of the battlefield that will influence friendly and threat operations, establishes the limits of the area of interest, and identifies gaps in current intelligence holdings. This focuses the command's initial intelligence collection efforts and the remaining steps of the IPB process.

(2) **Describe The battlefield's effects.** Step 2 evaluates the environment with which both sides must contend. The S2 identifies the limitations and opportunities the environment offers on the potential operations of friendly and threat forces. This evaluation focuses on the general capability of each force until COAs are developed in later steps of the IPB process. This assessment of the environment always includes an examination of terrain and weather. It may also include discussions of the characteristics of geography (MCOO) and infrastructure (politics, civilian press, local population, and demographics) and their effects on friendly and threat operations. Products developed in this step may include, but are not limited to--

- (a) Population status overlay.
- (b) Overlays depicting the military aspects and effects of terrain.
- (c) Weather analysis matrix..
- (d) Integrated products, including MCOO.

(3) Evaluate the threat. In step 3, the S2 and his staff analyze the command's intelligence holdings to determine how the threat normally organizes for combat and conducts operations. When facing a well-known threat, the S2 may use historical data bases and well-developed threat models. When operating against a new or less-known threat, the S2 may need to develop his intelligence data bases and threat models concurrently. The S2's evaluation is portrayed in a threat model that includes doctrinal templates that depict how the threat operates when unconstrained by the effects of the battlefield environment. Although graphic depiction is normally emphasized (doctrinal templates), threat models sometimes emphasize matrices or simple narratives.

(4) Determine threat courses of action. Step 4 integrates the results of the previous steps into a meaningful conclusion. Given what the threat normally prefers to do, and the effects of the specific environment in which the threat is operating, this step determines the threat's likely objectives and the COAs available to him. In step 4, the S2 develops likely COA models that depict the threat's available COAs. The S2 also prepares event templates and matrices that focus intelligence collection on identifying which COA the threat will execute.

d. IPB Results. IPB identifies facts and assumptions about the battlefield environment and the threat. This enables staff planning by focusing the development of both enemy and friendly COAs. IPB also provides the basis for intelligence direction and synchronization. IPB is vital to the commander's estimate and his tactical decision regarding the concept of the operation. It helps the commander to compare friendly and enemy vulnerabilities and opportunities accurately. It also helps him to determine where, when, and how to employ the ATKHB to ensure success. Finally, IPB contributes to complete staff synchronization and focuses the decision making process. Additional information on the IPB process is found in FM 34-130.

2-4. COMMAND AND CONTROL PROCESS

At any level of command, the C² process provides the commander with the structure and the means to make, convey, and evaluate decisions continuously. These decisions and the higher commander's intent are translated into productive actions. Upon receipt of the mission, the ATKHB uses the decision-making process to evaluate, plan, and accomplish the mission.

a. Decision Making. Decision making requires an organized effort by the ATKHB commander, his staff, and liaison officers to reach an effective solution that supports the friendly force commander's intent. The decision-making process begins when the mission is received from higher headquarters and continues until the mission is accomplished. The decision-making process is a multi-step approach which may be abbreviated if the situation dictates. If time or situation do not permit a formal decision-making process, parts of it may be done mentally by the commander and staff.

FM 1-112

(1) Mission analysis. Mission analysis is the first major step of the tactical decision-making process. It consists of command and staff actions related to:

- (a) Gathering facts (current status or conditions), including risk assessment.
- (b) Making assumptions (a substitute for facts if the information is not known).
- (c) Analyzing higher mission and intent (tasks required to accomplish the mission).
- (d) Issuing commander's guidance (focus for subsequent staff planning).

(2) COA development. To develop COAs, the staff must focus on key information necessary to make decisions and assimilate the data obtained in mission analysis. Each possible enemy COA should have at least one corresponding friendly COA to counter it. The ATKHB will often be given its COA by higher headquarters, but this should not stop the commander and staff from considering possible actions of an uncooperative enemy and planning for branches, sequels, and contingencies. While developing COAs, the staff goes through several steps--

- (a) Analyze relative force ratios.
- (b) Develop a scheme of maneuver.
- (c) Determine C² means and minimum required maneuver control measures.
- (d) Prepare COA statement(s) and sketches.

The COA may be revised, modified, or changed during wargaming. COAs are developed for all staff members to analyze.

(3) COA analysis and comparison. Staff analysis identifies the best COA for recommendation to the commander. Analysis begins when the ATKHB S3 briefs the staff about each COA. At this time, a quick analysis of each COA by the other staff members is conducted to determine any COAs that are not feasible. Those COAs should be eliminated immediately. During this analysis, information identified by any staff member that might effect another's analysis must be shared immediately. Subsequently, each staff member conducts detailed analysis of each COA. Analysis evaluates each COA against time, space, and means. If a COA is deemed inadequate in terms of feasibility the staff must modify or eliminate the COA and restart the analysis process. Once a COA passes the feasibility analysis, the planners can analyze it for acceptability. Each staff member must analyze the COA using wargaming techniques. The COAs should be

wargamed independently of one another. Once wargaming is completed, a comparison of the COAs determines which COA best accomplishes the mission.

(4) Decision and execution. After completing COA analysis, the staff conducts a decision brief, with a COA recommendation, to the commander. Each COA is outlined to the commander along with the advantages and disadvantages of each. The briefing will also contain the branches and sequels identified during the wargaming. The commander announces his decision at the conclusion of the decision brief. After receiving the commander's decision, the staff prepares the order or plan to implement the selected COA. During execution of the plan, the commander and staff respond to the changing situation through actions and orders while supervising the operation.

b. Planning. ATKHB operations must be planned in detail. Plans are based on specific conditions or assumptions and are not static. As a result of continuing estimates and studies, plans must be changed, refined, and updated. The ATKHB may have many on-order missions that cover the depth and breadth of the battlefield; therefore, planning is a challenging and never-ending process. Once a COA has been decided by the commander, planning must begin in earnest. Concurrent planning at all levels in the ATKHB is made possible with the AMPS. Chapter 3 contains specific information on planning attack helicopter operations from mission receipt to target attack.

c. Orders. Orders are written or oral communications that convey information governing the action. Some of the characteristics of a good combat order are clarity, completeness, brevity, and timeliness. Orders are covered in FM 101-5. A sample format for an operations order is contained in Appendix C of this manual.

d. Risk Management.

(1) Commanders are responsible for effectively managing risk. They must determine the proper balance to achieve optimum performance from their command, select the best risk-reduction options from those that the staff provides, and accept or reject residual risk based on perceived benefits.

(2) The XO ensures integration of risk management in all aspects of staff planning. In the risk management process, each staff officer must recommend appropriate control measures to reduce or eliminate risk, use risk management to assess his or her functional area, and integrate risk control into plans and orders.

(3) Troop leaders review control measures for feasibility and report risk issues beyond their control or authority to their seniors for resolution. In addition, they recommend changes to improve synchronization of their operations and use the risk management process to identify, assess, and control hazards for their mission.

(4) Risk-assessment procedures are organized into a five step risk management process.

FM 1-112

(a) **Step 1. Identify.** Identify the hazards with the major events that are expected to occur.

(b) **Step 2. Assess hazards.** Determine the level of risk associated with a given hazard and select appropriate control measures.

(c) **Step 3. Develop controls.** Balance a COA's benefits with its potential risks.

(d) **Step 4. Decide.** Implement and integrate selected controls into plans, OPORDs, SOPs, and rehearsals.

(e) **Step 5. Supervise.** The commander must enforce controls.

(5) FM 1-111 contains more specific information on risk management.

2-5. COMMAND POSTS

a. **Main Command Post.** The ATKHB main CP is the control, coordination, and communications center for combat operations. The main CP is located in or near the battalion assembly area and is composed of the S1, S2, S3, and S4 sections, the FSE (when present), representatives from other attached elements, and the tactical CP (when it is not forward). Main CP vehicles and personnel must be kept to a minimum to allow for rapid displacement; however, a sufficient number must be retained to perform C² functions in support of the commander. The battalion XO is overall responsible for the main CP.

(1) **Functions.** The main CP monitors and assists in C² by maintaining contact and coordination with higher and adjacent units and continuously updating the enemy situation. It also plans operations, analyzes and disseminates tactical information, maintains situation maps, and requests and synchronizes additional CS and CSS for the battle. Factors that have immediate operational impact must be monitored by the main CP and communicated to the commander.

(2) **Operations.** The primary considerations in positioning the main CP are communications, accessibility, and survivability. Personnel who operate the main CP must be organized to maintain the main CP functions and provide security on a continuous basis. A sleep plan must be enforced to preserve the ability of main CP personnel to perform continuous operations. Coordination between the S3 and the S1/S4 must be continuous to ensure that CSS is integrated into the mission effort, and the S1/S4 must continuously monitor the CSS status of the battalion and keep the XO informed. The security of the main CP is enhanced by its capability to displace rapidly and maintain a small electronic signature. Displacements are planned to ensure that the main CP is stationary during critical phases of the battle.

b. TAC CP. When established, the TAC CP is the forward echelon of the ATKHB headquarters. It usually consists of staff elements from the S2, S3, and any fire support control elements attached to the battalion. The S3 is usually located at, and has overall responsibility for, the TAC CP. The TAC CP is located well forward on the battlefield so the commander is near his subordinate units and can lead the battalion. The TAC CP is established in or near the forward assembly area. Once the ATKHB has crossed the LD and begun operations, the commander moves to a position from which he can coordinate operations. While the battalion is in the forward assembly area, the S3's and commander's vehicles normally compose the tactical CP. Upon execution of the mission, the command group moves to wherever the commander deems as the best place to C². This could be from an aircraft or from a ground vehicle. Figure 2-1 shows the TAC CP organization and its approximate position on the battlefield.

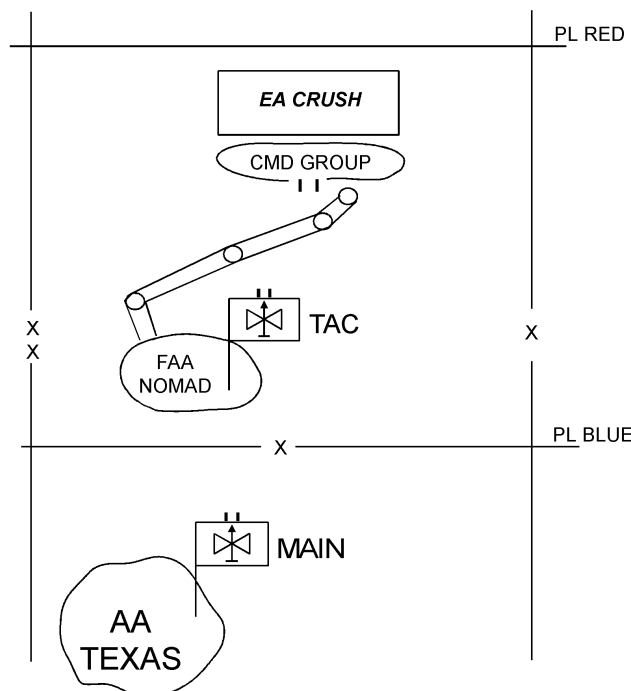

Figure 2-1. CP organization and location

c. Command Group. The command group consists of the commander and those personnel he selects to go forward to assist him in controlling maneuver and fires during the battle. The command group normally includes the FSO (if attached), FAC (if attached), and S3. There is no requirement for these people to collocate. For example, the commander and the S3 may fly in different aircraft so that during a continuous mission the S3 will remain on station to control the battle when the commander's aircraft must return to the forward arming and refuel point. To permit optimum C² of his unit

FM 1-112

during battle, the commander determines the composition, nature, and tasks of the command group.

2-6. COMMAND COMMUNICATIONS SYSTEMS

a. Attack helicopters play a key role in each of the functional areas of information operations. These functional areas are--

- (1) Gathering intelligence.
- (2) Attacking enemy C².
- (3) Protecting friendly C².
- (4) Construction of the information battlespace.

Attack helicopter operations in support of these functions may be conducted for commanders at the tactical to strategic level in every combat environment.

b. **Command Responsibilities.** The command transmits and receives information and orders through command communications systems. The commander must understand the capabilities, limitations, and vulnerabilities of his communication systems. Enemy radar, radios, and lasers may operate in the same electromagnetic spectrum as friendly equipment. The commander must expect unintentional interference from friendly units as well as interference from enemy units. Transmissions may also be hindered by terrain, atmospheric conditions, or electromagnetic pulse from nuclear blasts. To compensate for these, the commander should--

- (1) Provide for redundancy in the means of communication.
- (2) Ensure that subordinates understand his intent so that they will know what to do when communications are interrupted.
- (3) Avoid overloading the communication systems by using them only when necessary.
- (4) Use wire or messenger when possible instead of radio.
- (5) Ensure proper signals security practices are followed.

c. **Signal Support.** Maintaining communications with higher and subordinate headquarters presents a challenge for the battalion's communications section. Assets available to the ATKHB are limited, particularly for FM(s) sets. In addition to the FM radios on battalion vehicles and aircraft, communications support for the ATKHB headquarters is provided by two organizations--the communications section in the battalion HHC and the signal platoon in the brigade HHC. The communications section

provides primarily FM and wire communications. The brigade's signal platoon assists in providing MSE and SATCOM as required.

d. Unit/Staff Responsibilities. All levels of command and staff must gain and maintain communications with the necessary headquarters and personnel. The traditional communications responsibilities of ATKHBs are covered below.

(1) Higher to subordinate. The battalion headquarters must ensure that its radio nets (command, O&I, administrative and logistics, and fire support) are continually operational. The RETRANS system must be dedicated to on-call restoration of communications on any net. Possible RETRANS locations must be identified and checked before starting operations. All key personnel must understand the operation of the RETRANS system.

(2) Subordinate units. Subordinate units within the battalion must continually monitor key battalion level radio nets. At a minimum, subordinate units must monitor the battalion command and O&I nets.

(3) Supporting to supported. Liaison elements supporting the battalion must maintain communications between their organization providing the support and the ATKHB. Once located at the tactical CP, main CP, or rear CP, these units will be controlled by the battalion staff and the headquarters commander.

(4) Lateral communications. Responsibility for establishing communications between adjacent units may be fixed by the next higher commander. If responsibility is not fixed by orders, the commander of the unit on the left is responsible for establishing communications with the unit on the right. The commander of a unit positioned behind another unit establishes communications with the forward unit.

(5) Restoration. Regardless of the responsibility, all units act promptly to restore lost communications.

e. Command Communications Systems Architecture.

(1) Army aviation is required to deploy anywhere in the world and operate under most types of environmental conditions. Mission parameters, therefore, require a C² system designed to support the commander's needs throughout every phase of the force-projection cycle. The Army has selected battlefield digitization to support the commander's communications requirements.

(2) Digitizing the battlefield is the application of technologies to acquire, exchange, and employ timely digital information throughout the battlespace, tailored to the needs of each decider, shooter, and supporter. Digitization allows each soldier to maintain a clear and accurate vision of the common battlespace necessary to support planning and execution. This common picture/situational awareness permits commanders

FM 1-112

at all echelons to better control forces, synchronize effects, and achieve decisive victory with minimal casualties.

(3) Integrated digital system networks (command, control, communications, computers, and intelligence and weapons systems) provide commanders, staffs, sensors, and shooters with a great technological advantage. Information exchange between command communications systems includes, or will include, relative positioning, identification, time, way points, direction, azimuth, targeting, support, coordination, etc.

(4) Some of the key command systems providing for ATKHB's internal/external communications linkages are as follows:

(a) **CNR.** ATKHBs will conduct operations over extended distances using CNR as the primary means of communication. CNR is a system of systems. CNR consists of a single channel ground airborne radio system, a TACSAT communications system, and high frequency radios.

(b) **MSE.** MSE is a compact mobile communications system providing secure voice, data, and facsimile capabilities. MSE allows the commander to exercise C² over forces in a rapidly changing environment. The system is interoperable with CNR, commercial, and NATO standard systems.

(c) **HF NOE COM.** The HF NOE COMM provides the commander with uninterrupted NOE communications over extended distances. This radio is equipped for digital communications, and can adjust input/output to accommodate interference and path loss.

(d) **Have Quick II.** Have Quick II helps the commander facilitate Army and joint services communication. The system is a UHF radio that frequency hops to reduce its susceptibility to jamming and interference. The radio can be used for digital target handover and information/intelligence flow between Air Force close air support, OH-58D (I) Kiowa Warrior, and the AH-64D Apache Longbow.

(e) **MCS-P.** One element of the Army battle command system, MCS provides two major functional capabilities; maneuver functional area control (maneuver unit situational awareness) and force level information (critical sustainment information). MCS provides commanders and staffs the capability to collect, coordinate, and act on near-real-time battlefield information. Commanders and staffs can readily access information and display current situation reports that assess enemy strength and movement, as well as the status of friendly forces. MCS can then aid the battle staff in rapidly disseminating the commander's orders.

(f) **Aviation mission planning system.** The AMPS provides the commander and staff an automated mission planning and battle synchronization tool. AMPS functions include tactical C², mission planning, mission management, and maintenance management. The AMPS provides an interface to the MCS. This provides

the aviation commander with continuous updates of the friendly and enemy situation and allows the commander to rapidly adjust current and future operational plans.

(5) Other key elements of the Army battle command system that the ATKHB will have to interface with include:

(a) **ASAS**. The ASAS provides IPB information used by all echelons for planning combat operations. The ASAS cell is located at the division and corps TOCs and the Aviation Brigade will interface with it via the MCS computer through an area common user system network. During operations, the MCS alone is unable to update the current intelligence picture frequently enough for Army Aviation operations. Real time air threat, ground ADA, and SAM locations must be passed to aviation TOCs, both ground and airborne within seconds of discovery. The commander's tactical terminal hybrid system will provide the commander with this near real time tactical intelligence. It is a receiver processor that extracts intelligence broadcasts from several overhead sources.

(b) **AFATDS**. The AFATDS controls all fire support operations for the corps and division artillery brigades. The Aviation Brigade and battalion TOCs nominate targets and submit requests for fire support through the MCS computer via the ACUS. The fire support element at brigade determines which targets will be serviced by assets under brigade control. The rest are submitted to division that performs the same filtering process and sends a consolidated list to the corps FSE. During the conduct of tactical operations, the ATKHB coordinate directly via SINCGARS and Have Quick radios to fire support teams and forward air controllers to place ordnance at the right place and time. These communications are mostly digital, using modems, and the message formats of AFATDS or the variable message formats.

(c) **FAAD**. The FAAD provides an overlay of battery coverage areas to the MCS computer via ACUS. The FAAD system accepts feeds from AWACS and organic ground based radars to generate a real time air picture. The Aviation brigade will access this information via EPLRS over a local area users network and pass the critical elements to its aircraft digitally using HF-NOE-COM radios and modems.

(d) **CSSCS**. The CSSCS is a computerized system for the control of most classes of supplies, equipment, and personnel replacements. The CSSCS provides information on the status of units and equipment to the MCS computer for transmission to users over the ACUS. The ATKHB uses CSSCS software on a common computer to perform its administrative and logistics requests and reporting functions.

f. Transmission Limitations.

(1) Because of the ATKHB's mobility and potential for operating throughout an entire AO, the primary means of communication will be radio. However, some radio communications are limited by range and line-of-sight restrictions. In these situations, commanders may lose contact with their aviation units unless radio relays are used. Radio communications should be kept to an absolute minimum until enemy contact is made. Other means to communicate should be used until the radio is necessary so that detection by enemy direction-finding equipment is avoided.

(2) Satellite channel availability may be limited for several reasons, especially during early entry operations. Factors such as world-wide geographical location and unit density per satellite ratios may restrict commanders from continuous transnational/over-the-horizon communications.

2-7. COMMUNICATIONS

a. Radio Nets. Successful employment of the ATKHB depends on its ability to communicate with all echelons. The primary means of tactical communications within the ATKHB is the FM-secure net. The use of UHF and VHF radios in battalion aircraft helps reduce the load on the FM-secure nets. These radios are primarily used by the ATKHC to control the platoons. The ATKHB commander normally communicates from his aircraft to higher headquarters using the FM-secure net. The battalion command net is also FM-secure; however, this requires that the commander relay messages to higher headquarters through the main CP, TAC CP, or change frequencies when communications are necessary with higher headquarters. Figures 2-2 and 2-3 show sample radio nets for an ATKHB.

b. Wire. Though its wire laying capability is limited, the ATKHB has the assets to establish wire communications in the assembly area. This wire network links the main CP with elements of the HHC, the AVUM company, and ATKHCs. Figure 2-4 shows a battalion wire net.

2-8. OPSEC

Security measures must be taken during any military operation to deny the enemy information about friendly forces. The OPSEC concept includes all security measures that allow units to surprise or deceive the enemy. OPSEC includes physical security, information security, SIGSEC, and deception and countersurveillance activities. Because these categories are interrelated, the ATKHB commander normally chooses to employ more than one security technique to counter the threat. He may also use SIGSEC programs such as electronic warfare and SIGINT. By analyzing hostile intelligence efforts and vulnerability, executing OPSEC countermeasures, and surveying the effectiveness of countermeasures, the ATKHB commander can counter specific hostile intelligence efforts. Aviation OPSEC is described in detail in FM 1-111.

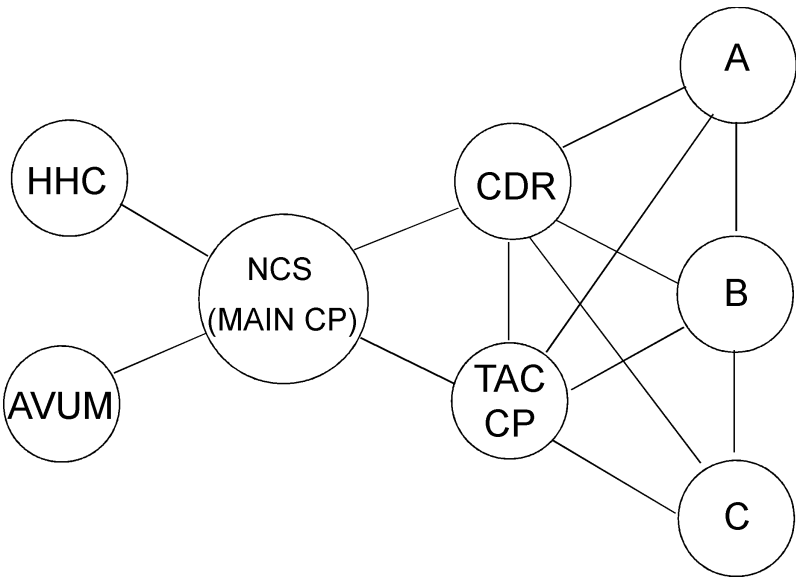

Figure 2-2. Sample battalion command FM net (Secure)

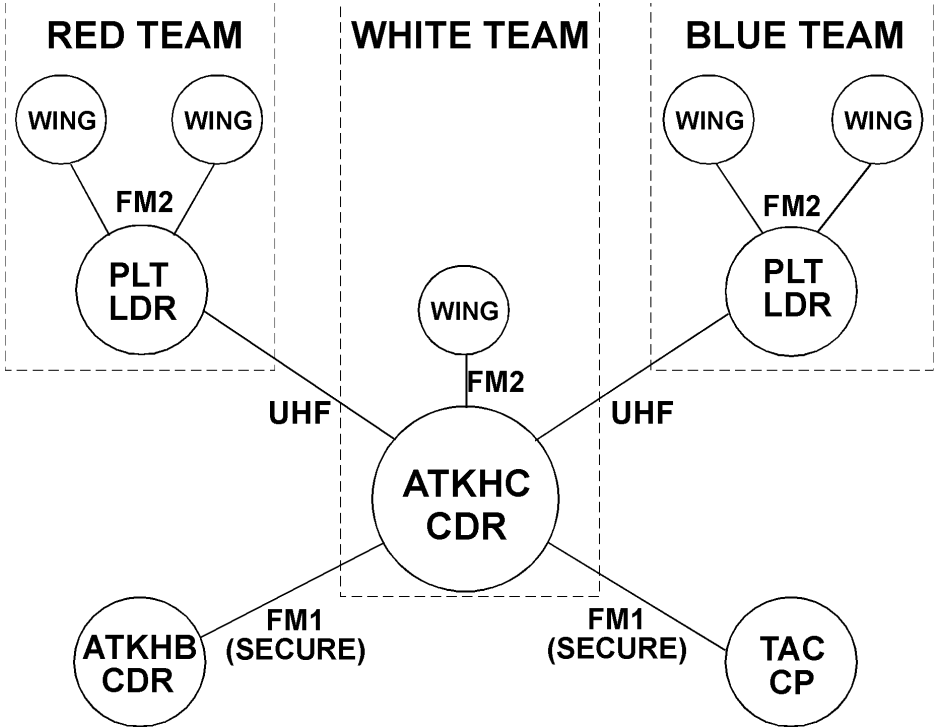

Figure 2-3. Sample company nets

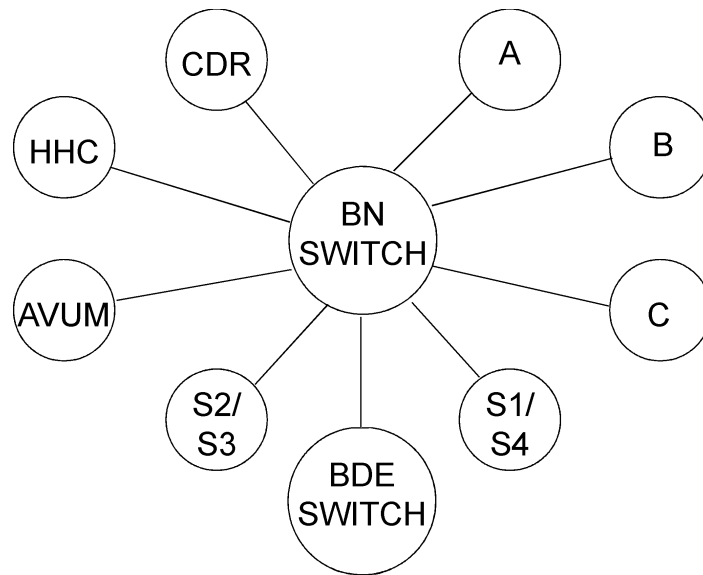

Figure 2-4. Sample battalion wire net

CHAPTER 3

EMPLOYMENT

Section I. Organization and Roles

3-1. ORGANIZATION

a. **ATKHB.** The ATKHB is task-organized according to the factors of METT-T. As the situation dictates, the aviation brigade commander can organize the ATKHB with other assets to form TFs to better perform specific missions.

(1) **Pure.** To take advantage of its speed and mobility against armored forces, the ATKHB fights pure. When commanders desire to emphasize the shock and killing effect of massed ATKHBs, they will use the organic structure of the battalion.

(2) **TF.**

(a) To provide lift capability to an ATKHB, the brigade commander can attach a platoon of assault helicopters from an assault helicopter company. Figure 3-1 shows additional lift assets attached to an ATKHB. The addition of utility helicopters allows the ATKHB to move Class III/V supplies by air. ATKHCs may be OPCON or attached to other aviation units based on the duration of the commitment and sustainment support capability.

(b) When there is a constant requirement for attack helicopters to provide security for assault helicopters, the aviation brigade commander may task-organize both the ATKHB and assault helicopter organizations by moving elements between the two. Figure 3-2 shows two TFs formed in a heavy division. When creating two TFs, the aviation brigade commander trades the ability to mass his attack helicopters for better security for his assault helicopters. When attack helicopter companies are attached to assault helicopter units to form TFs, sufficient Class V and armament support must also be attached. ATKHBs may also form TFs with ground forces. Ground maneuver units may be placed under OPCON of the ATKHB to perform specific missions. The ATKHB may place an ATKHC under OPCON to a ground brigade for limited periods of time or for a specific mission at the direction of the brigade commander.

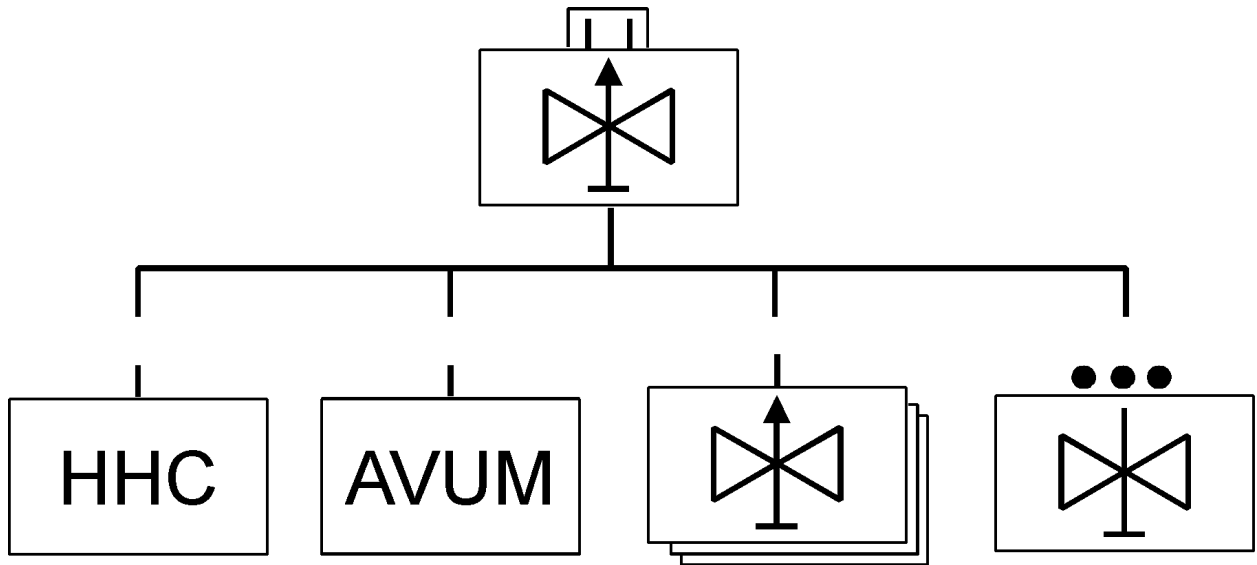

Figure 3-1. ATKHB with lift assets

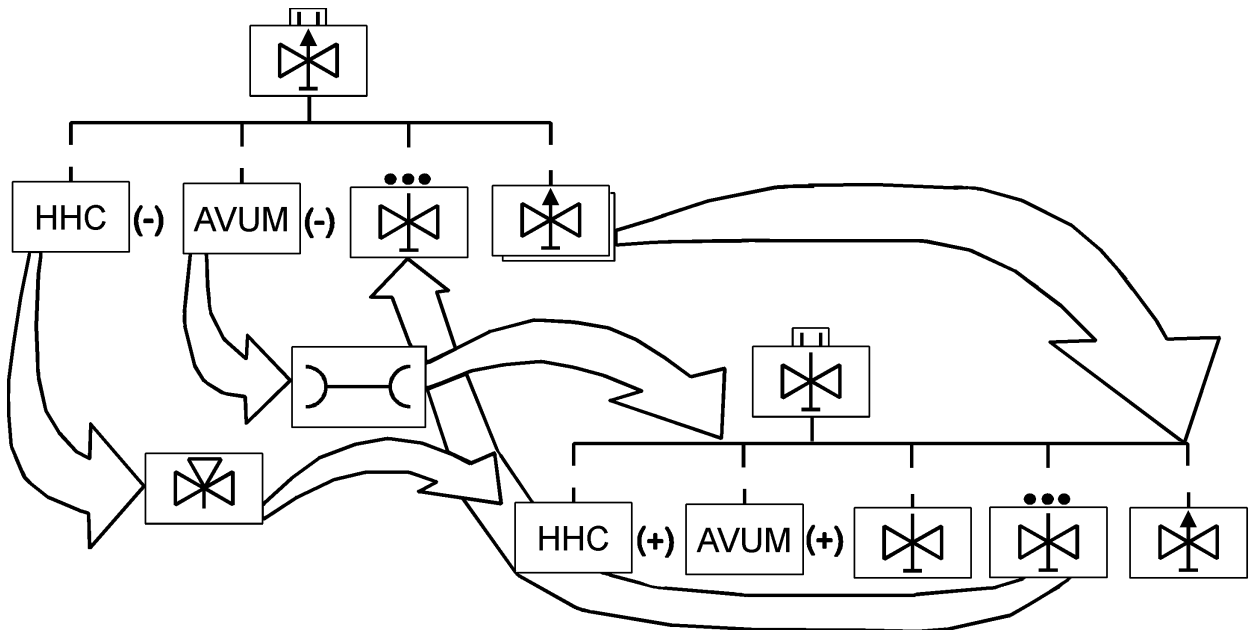

Figure 3-2. Two TFs formed in a heavy division

(3) Augmented. At times, an ATKHR or aviation brigade commander may be required to reinforce an attack battalion with an additional ATKHC (Figure 3-3). An ATKHB can control up to five maneuver companies; more than five companies will tax the battalion's capability to support them logistically.

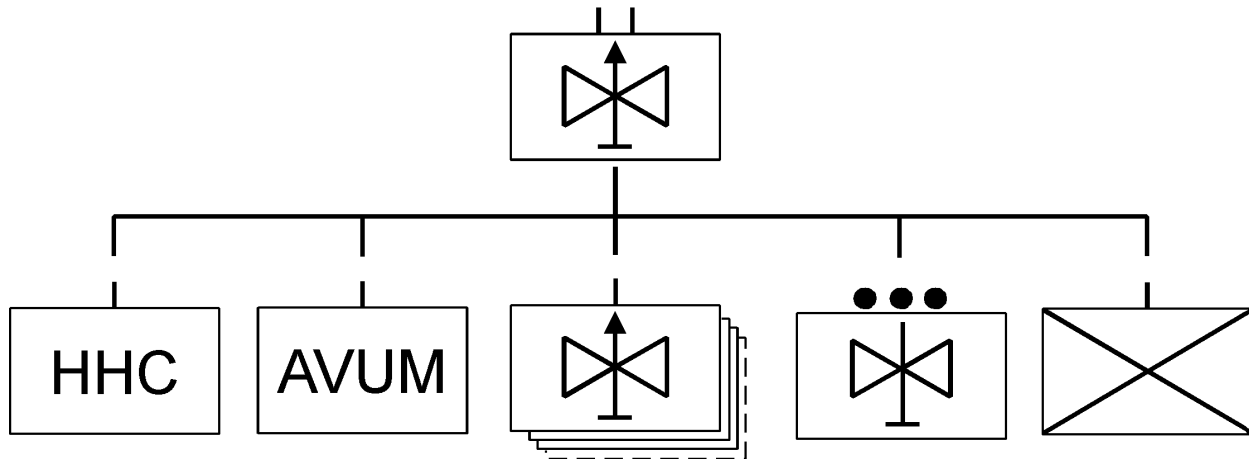

Figure 3-3. Augmented ATKHB

b. ATKHC.

(1) ATKHBs are organized with ATKHCs. These companies are organized into two platoons. An ATKHC has a standard chain of command that leads and fights the unit as a company. The chain of command includes a company commander and two platoon leaders. The battalion assigns the ATKHC specific missions as part of the battalion's plan of attack.

(2) The ATKHC commander task-organizes his company for combat based upon the factors of METT-T. There is no single method to task-organize an ATKHC. Company commanders must understand the battlefield and adjust for conditions and the availability of aircraft when deciding how to organize for combat. The organization of ATKHC assets is based on pairs of aircraft (L/W) known as "teams" operating together to provide mutual security. If there is an odd number of aircraft, one team will consist of a lead aircraft and two wingmen. Aircraft without wingmen are vulnerable.

(3) When task-organizing the company, the ATKHC commander will always attempt to create a balance between the combat power necessary to accomplish the mission and the need to provide security for each aircraft and the company as a whole. References to "scout" or "attack" aircraft indicate the role of the aircraft, not the aircraft type. This reflects the pure (ARI) structure of the ATKHC, as well as the "scout" and "attack" platoons specified by the MTOE. This organization allows flexibility, and aircraft configurations will vary to perform the scout or attack role. Below are several examples of how an ATKHC may be task-organized for combat.

(a) **L/W teams.** The ATKHC commander may organize the company into L/W teams. For planning purposes, three L/W teams should be available per company; however, the commander will use the available aircraft as necessary to accomplish the mission. This organization allows greater freedom of maneuver and maximum employment flexibility. Each L/W team is made up of two aircraft that can operate and provide mutual security for each other. Using three L/W teams facilitates C² by placing a platoon leader in two of the teams and the company commander in the third team. Figure 3-4 shows an ATKHC task-organized into L/W teams.

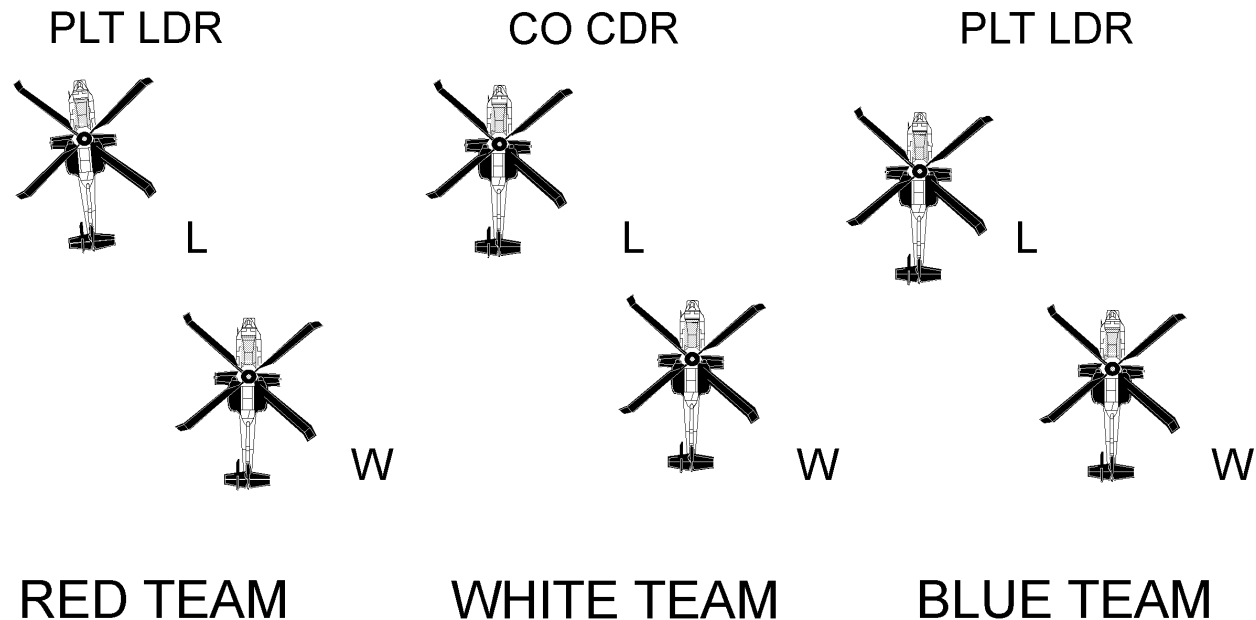

Figure 3-4. ATKHC task-organized into L/W teams

(b) **Platoons.** L/W teams combine to form platoons that can provide security, facilitate C² or be assigned specific tasks or responsibilities (calling for FS, controlling air assets, etc.). These platoons, based upon the missions and C³ requirements, may be called heavy and light platoons, scout and attack platoon, or a

generic name (such as red and blue platoons). The platoon may be made up of L/W teams that contain either two attack aircraft, two scout aircraft, two scout/attack aircraft, or one scout and one attack aircraft. Figures 3-5 and 3-6 show an ATKHC task-organized into platoons.

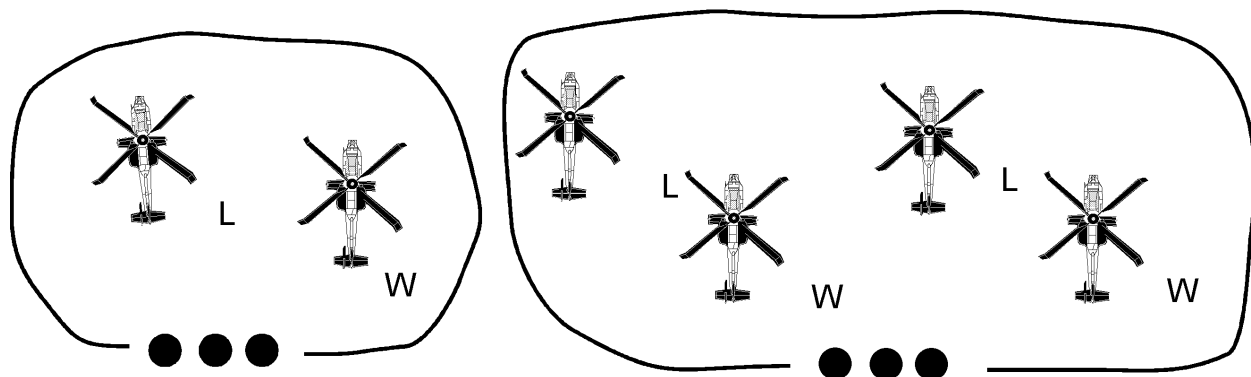

Figure 3-5. ATKHC task-organized into platoons

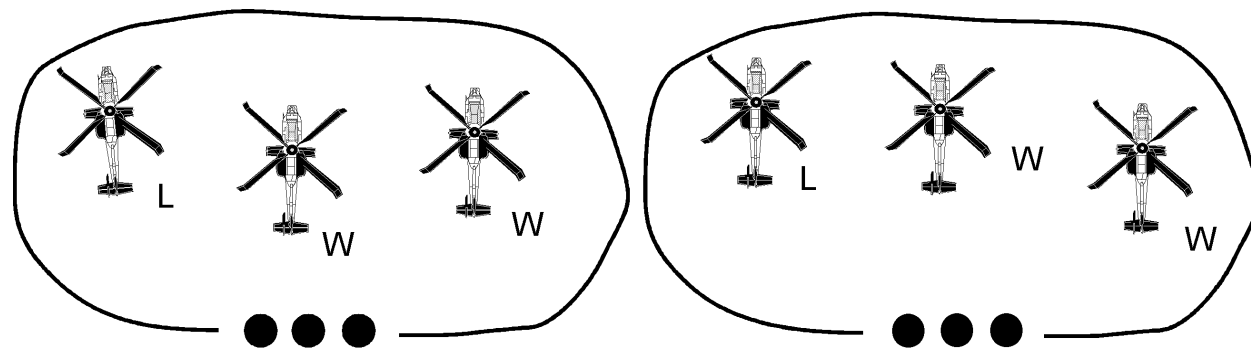

Figure 3-6. ATKHC task-organized into two platoons

NOTE: The terms "heavy" and "light" refer to the mission and weapons load of the attack aircraft, not the number of aircraft. Heavy platoon aircraft will normally be fitted with more ATGMs and concentrate on heavy armored targets. Light platoon aircraft will normally be loaded with more rockets and machine gun/cannon ammunition and will attack targets of opportunity and provide suppressive fires for the heavy platoon.

3-2. ROLES AND RESPONSIBILITIES

The ATKHC is a versatile organization that can conduct offensive operations (attack, movement to contact), defensive operations (area defense, mobile defense), reconnaissance, and security. In addition, the ATKHC can conduct special purpose operations such as air assault security (an advance guard that is a combination of attack, reconnaissance, and security) and raids (commonly referred to as deep attacks).

a. Key Leaders.

(1) ATKHC commander. The ATKHC commander is responsible for everything that his company does or does not do. He fights the battle. The commander establishes attack priorities, plans and directs fire distribution, and controls supporting fires. He normally operates from an attack aircraft and maneuvers attack and scout assets during an engagement. The ATKHC commander--

- (a) Receives the mission from the battalion.
- (b) Task-organizes the company.
- (c) Provides detailed planning guidance to crews.
- (d) Coordinates with supported ground units.
- (e) Confirms BPs for the company and selects platoon and team BPs.
- (f) Plans routes to the HA and BP.
- (g) Coordinates indirect FS and CAS.
- (h) Keeps the battalion informed through situation, spot, and BDA reports.
- (i) Plans for local security in the assembly area, the FAA, and HAs en route and in the BP.
- (j) Plans the engagement from the BP and makes a detailed preparation of the EA.
- (k) Controls the joint air attack during company-level JAAT operations.
- (l) Controls company fires.
- (m) Coordinates battle handover and receives a briefing from the unit to be relieved.

- (n) Briefs the incoming ATKHC commander during relief on station.
- (o) Maneuvers the company to the FARP and controls refueling and rearming operations.
- (p) Conducts the debriefing.
- (q) Prepares for future operations.

(2) **Company first sergeant.** The ATKHC first sergeant is the commander's advisor for all matters concerning enlisted soldiers. Additionally, he is the key logistician for the company and the leader and mentor to the company's enlisted soldiers. He--

- (a) Assists the commander with the training, maintenance, logistics, and administration of the company.
- (b) Checks soldiers, to ensure they are physically and mentally prepared for combat.
- (c) Conducts precombat inspections.
- (d) Normally leads the company quartering party and ground assets to a new assembly area.
- (e) Plans and supervises the company CSS plan, receiving and processing logistics reports from the platoons and coordinating for supplies, equipment, and personnel.
- (f) Orients new personnel to the company and assigns them to platoons.
- (g) Coordinates company force protection measures.

(3) **Platoon leader.** ATKHC platoon leaders are responsible for leading their platoons. The platoon leaders are critical to the successful employment of the ATKHC. When the platoon is task-organized, the platoon leaders control the task-organized platoon or a team. Platoon leaders--

- (a) Assist in planning company missions.
- (b) Control the fire and maneuver of their platoons or teams.
- (c) Fight their own aircraft.
- (d) Assist the ATKHC commander, at his direction, to execute missions.

b. Aircrews.

(1) Scout. The mission of ATKHC scouts is to see the battlefield, find the enemy, coordinate its destruction, and provide security against ground and air threats. Normally, scouts in each task-organized platoon accomplish the scouting tasks; however, both the designated scout and attack aircrews must be able to perform them. Regardless of which aircrew is performing the mission, the scouting tasks must be performed. These tasks include:

- (a) Requests and adjusts indirect fires and CAS.
- (b) Provides early warning and confirms BPs.
- (c) Coordinates operations and develops the enemy situation.
- (d) Assists the company commander in controlling JAAT operations.
- (e) Assists with the movement of attack helicopters to BPs.
- (f) Designates targets for acquisition and engagement by laser-guided munitions.
- (g) Hands-over targets verbally or digitally.
- (h) Maintains enemy contact as attack helicopters move between BPs.
- (i) Acquires, identifies, reports, and designates targets.
- (j) Provides attack helicopters with local security and protection from air threats while they engage targets.
- (k) Assists attack aircraft by confirming or selecting firing positions that provide concealment and standoff ranges.

(2) Attack. Attack aircrews destroy enemy forces and their supporting systems. Regardless of which aircrew is performing the mission, the attack crew--

- (a) Coordinates with the scout.
- (b) Moves to the BP, selects the firing position, and receives the target handover from the ATKHC commander or scout.
- (c) Acquires and engages targets.
- (d) Moves to an alternate position and reengages.

(e) Moves to a successive or supplementary position or HA or returns to the FARP.

(3) **Scout/attack.** Scout/attack is the preferred role for aircraft in ATKHBs. Scout/attack refers to performing a combination of the scout and attack tasks during the conduct of a mission. In addition, crews must be prepared for the role of the scout/attack crew may change during a mission.

(4) **Utility aircrews.** Utility aircrews and their aircraft will support attack helicopter operations. Utility aircraft are required for the successful conduct of most attack missions. Some of their uses include--

- (a) Commanding and controlling assets at battalion level.
- (b) Conducting CSAR.
- (c) Conducting DART operations.
- (d) Providing lift capability for logistics operations such as jump FARPs and jump TOCs.

NOTE: Utility aircrews habitually supporting ATKHB operations must become familiar with this manual and with the SOPs of the supported attack unit.

Section II. Terms and Missions

3-3. OPERATIONAL TERMS

a. **Assembly Area.** An assembly area is a location where the ATKHB prepares for future operations, issues orders, accomplishes routine maintenance, and completes Class I, III, and V resupply activities. The battalion main CP is located in or near the assembly area. Assembly areas should be located out of enemy artillery range and be large enough for dispersion of the unit. Assembly areas are normally located in the corps or division rear area and in the aviation brigade assembly area. However, corps and division aviation brigade assets are normally dispersed over large areas to preclude their becoming lucrative targets. Assembly areas will not be located along an axis of advance. Other considerations involved in selecting appropriate assembly areas are--

- (1) Security.
- (2) Concealment.
- (3) Accessibility to MSRs.

FM 1-112

- (4) Air avenues of approach.
- (5) Location of friendly units.
- (6) Suitability of ingress and egress routes.

b. FAA. An ATKHB occupies FAAs for extended periods while awaiting orders to execute missions. FAAs are located near the controlling headquarters to improve C³I and response times. The FAA should be located out of range of enemy medium artillery. Limited maintenance personnel may be located in the FAA as contact teams move forward to repair aircraft. Considerations for selecting FAAs are the same as those for selecting assembly areas.

c. HA. A HA is a covered, concealed position that is occupied for short periods. Occupation of a HA allows for final reconnaissance and coordination of assets by the ATKHC commander. It is located between the FAA and the objective area. While occupying a HA, aircraft may be hovered or landed but they will not be shut down. Based on METT-T, the attack helicopter crews should consider moving to an alternate HA or returning to the FAA if they have to wait longer than a few minutes. Units that occupy HAs should ensure that--

- (1) Aircraft maintain operating RPM.
- (2) Crews maintain radio listening. silence.
- (3) Separate HAs are established for each company.
- (4) Aircraft remain at NOE altitudes at and near the HA.
- (5) Aircraft establish positions that provide 360-degree security.
- (6) The HA is terrain-masked and free of sources of rotor wash signature.
- (7) Copilot-gunners dismount for face-to-face coordination with the ATKHC commander and scouts.
- (8) Aircraft are dispersed and maintain platoon integrity while keeping intervisibility for security.

d. Attack Route. Attack helicopters move from the HA to the BP over attack routes. Properly selected attack routes allow attack helicopters to move undetected, ensuring initial surprise in the attack. Scouts select attack routes that provide cover and concealment and have prominent terrain features to assist in navigation. When used properly, vegetation and various terrain features can reduce helicopter noise and decrease the possibility of detection. ATKHCs may have multiple ingress and egress routes.

e. **BP.**

(1) The ATKHC may engage targets from concealed BPs designated in the OPORD or FRAGO. BPs are ideally suited for close-coordination attacks, such as those conducted in the ground unit's sector in the defense or deep attacks where there is extensive intelligence or operational reason mandating the specific place in the battlespace from which the attack must be made.

(2) The ATKHC commander uses information from the scouts to confirm BPs and assign platoon BPs and sectors of fire. The ATKHC disperses in the BP based on terrain. Scouts maintain contact with the targets and call up attack helicopters as enemy forces come into range, which reduces the exposure time of the attack helicopters. As the attack helicopters engage targets, scouts provide security and early warning by observing ground and air avenues of approach into the BP. BPs and their preparation are described in paragraph 3-8. Figure 3-7 shows the layout of the battlefield.

f. **ABF Position.** If the enemy situation is vague, as in a movement to contact, and the ATKHB commander has been assigned his own sector, ABF positions may be used. An ABF position is one from which a unit will engage a target, but not maneuver over it, with the intent of inflicting some level of damage. ABF positions are less restrictive than BPs, and better suited to a fluid battlefield. The commander must, however, control all indirect fires into his sector and know the locations of all his ATKHCs to clear those fires. See figure 3-8.

g. **SBF Position.** The SBF position will normally be used in conjunction with the ABF position, as a base of fire or overwatch position. It can be used to engage a target while ground or air assets move to or around it. Engagements from the SBF position may range from suppression to destruction of the target, but the primary mission is to fix the target so another force may maneuver. See figure 3-9.

h. **Firing Position.** Attack helicopter PCs select the actual firing positions that provide standoff ranges and good fields of fire within their BP, ABF, or SBF. Ingress and egress routes should be well-concealed, and the background of the firing position should reduce the risk of visual acquisition by the enemy. Selected firing positions must also allow freedom of movement for the attack helicopters and permit them to be hovered without raising dust or debris. To increase aircraft survivability, attack helicopter aircrews should limit the number of engagements from a single firing position and move before they receive effective counterfire.

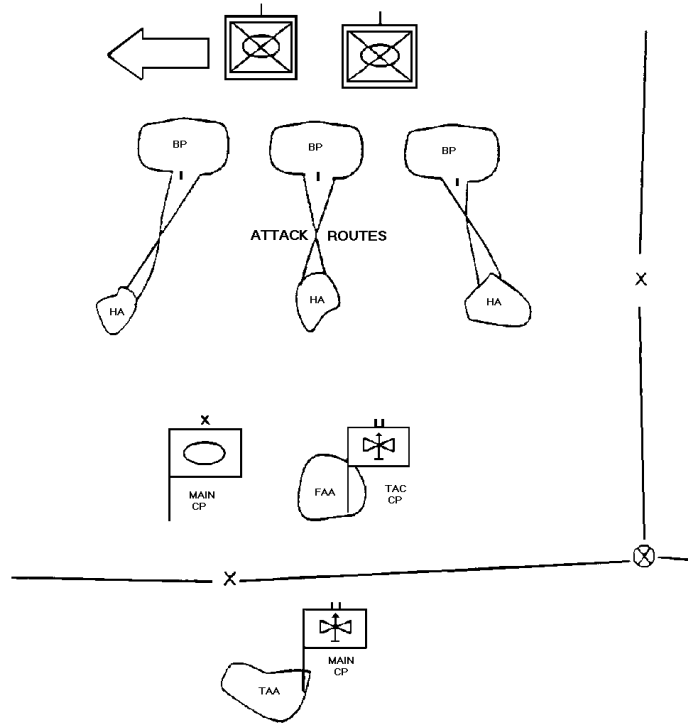

Figure 3-7. Battlefield layout

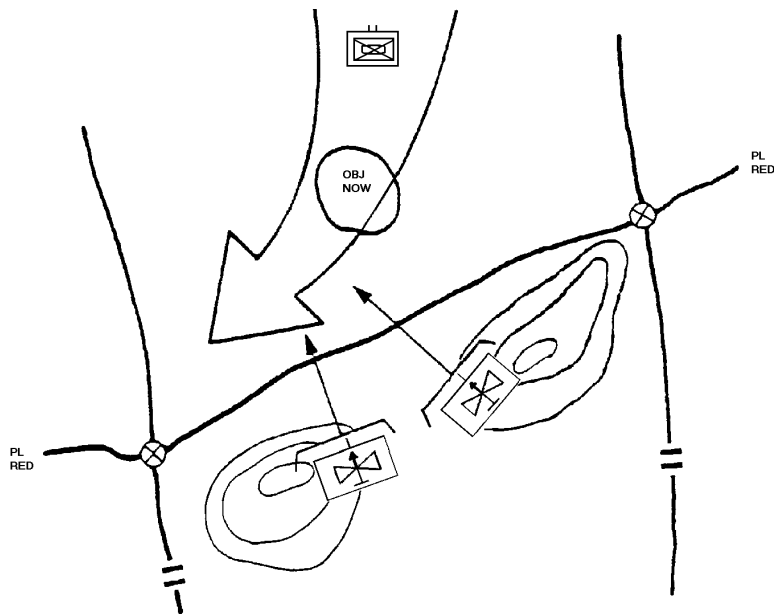

Figure 3-8. ABF as part of a movement to contact

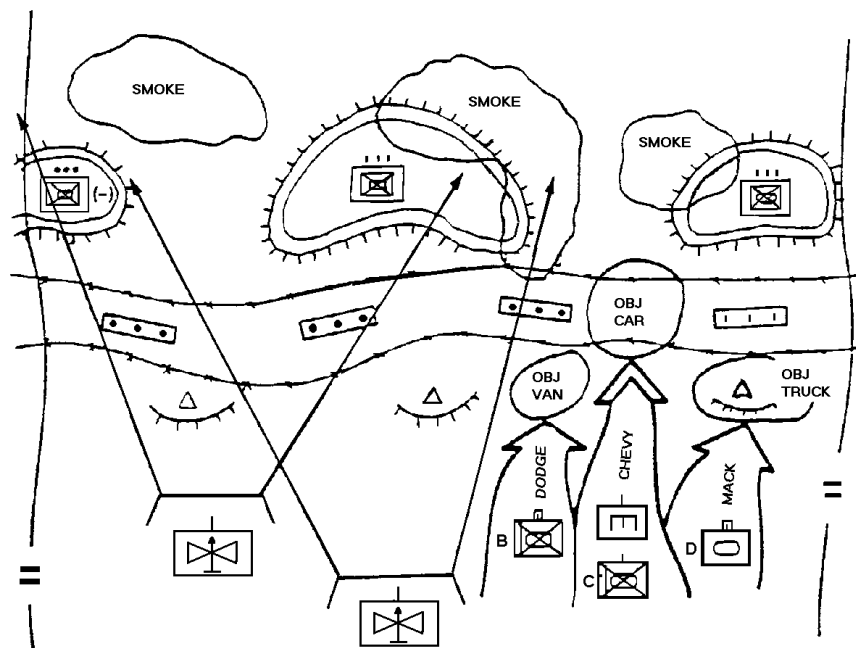

Figure 3-9. SBF used to overwatch ground maneuver

i. EA. The EA is an area in which the commander intends to trap and destroy an enemy force with the massed fires of all available weapons. Commanders must use obstacles, FS, fire distribution plans, and a thorough IPB to coordinate both combined and joint fires and mass them against the enemy force as it arrives in the EA. To exploit enemy weaknesses and maximize the advantages of terrain, battle and firing positions are selected in relation to EAs. A good EA should have at least the four characteristics listed below.

(1) BPs. The EA should have several BPs for attacking the enemy from various directions.

(2) Obstacles to movement. Obstacles, either natural or man-made, are desirable in the EA to slow target movement and permit the effective use of direct and indirect fires.

(3) Long-range fires. To enhance aircraft survivability, an EA should allow aircrews to engage targets at the maximum range that permits a high P_k .

(4) Continuous target visibility. Long-range engagements require that the target be in view during terminal guidance. As a rule, EAs should provide an unobstructed view of the target from firing or designating positions. Planning should concentrate on sensor ranges, not weapon maximum standoff ranges, for EAs.

j. Rally Point. A rally point is a designated area where separated or dispersed elements of the ATKHC reassemble. It may be used to reform the light and heavy platoons after an attack or to regroup a team, platoon, or company after a hasty withdrawal from untenable BPs.

3-4. EMPLOYMENT METHODS.

The ATKHB commander employs the battalion through the coordination of his ATKHCs, CS, and CSS. He uses his attack companies to destroy enemy forces. To do this, he applies one of three methods of employment--continuous attack, phased attack, or maximum destruction. Timing is critical in the employment of the ATKHB. Employed too early, it may have to be disengaged before mission completion because of low fuel. Employed too late, it may miss part or all of the targeted unit and fail to destroy the enemy forces at the critical time and place. The ATKHB should be employed when a lucrative target has been identified and selected for engagement.

a. Continuous Attack. To exert constant pressure on the enemy force, the ATKHB commander employs the ATKHCs using the continuous attack method. This method ensures that at least one company will be in the battle at all times. While one company is in the battle, the other two prepare to relieve the engaged company as they remain in HAs or the FARP or move between the FARP and the battle. Many times during a continuous attack the ATKHC commander on station may send only the attack helicopters to rearm and refuel. This allows the scouts to remain in enemy contact, coordinate with the relieving ATKHC commander, and reconnoiter successive BPs. Multiple BPs, ABF positions, or SBF positions selected during mission planning provide the flexibility needed for a coordinated battle handover between companies. The continuous attack method provides the most flexibility and the most efficient FARP operations. It also provides sustained fires over long periods. Figure 3-10 shows the continuous attack method.

b. Phased Attack. The phased attack method is a modification of the continuous attack method and is used to increase the initial firepower of the battalion. Using this method, the commander initially employs one company to begin the attack. He then quickly phases in the second company from a different BP. The third attack company is phased into the fight when either of the other companies is low on fuel or ammunition. The phased attack method may be reversed, or the commander may vary how the phased attack is conducted. For example, he may employ one company to set up the fight and then exploit the attack with his other two companies. If the phased attack method is used, aircraft turnaround time in the FARP must be kept as short as

possible. Because of FARP limitations, eventually the phased attack method reverts to the continuous attack method. Figure 3-11 shows the phased attack method.

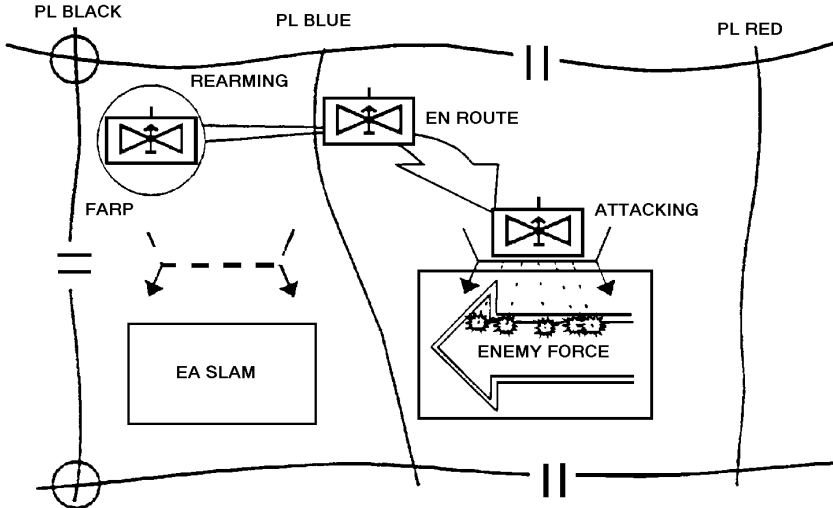

Figure 3-10. Continuous attack method

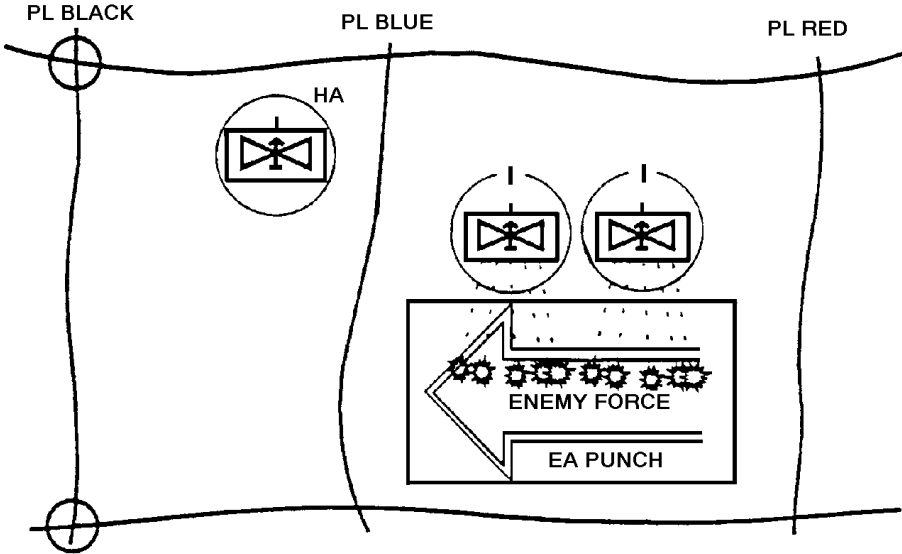

Figure 3-11. Phased attack method

c. **Maximum Destruction.** If the ATKHB commander wishes to place as much combat power as possible into the battle, he uses the maximum destruction method. To overwhelm the enemy with massed fires, the battalion deploys with all three companies in contact from different positions. In this situation, the supported commander must realize that the ATKHB will be out of the fight for 20 to 90 minutes at the completion of its initial attack. The exact time depends upon the distance to the FARP and the time it takes to replenish fuel and ammunition after the initial engagement. Figure 3-12 shows the maximum destruction method.

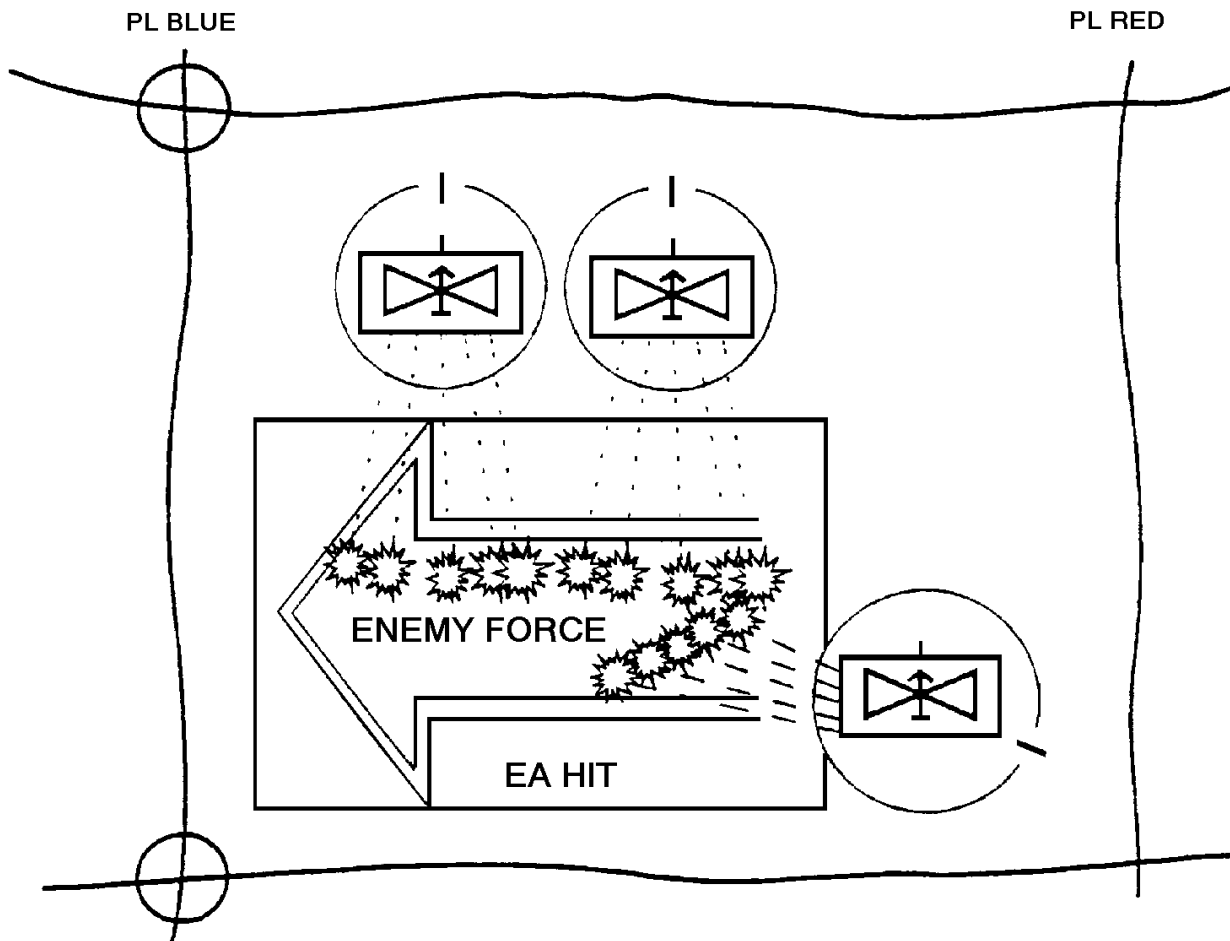

Figure 3-12. Maximum destruction method

Section III. Environmental Considerations

3-5. ENVIRONMENTAL FACTORS.

On the battlefield, each belligerent will attempt to use the environment to his advantage. The environment includes what we can see (terrain, visible light, weather, and obscurants) and what we cannot see (electromagnetic measures, CB pollution, and battlefield stress). As part of the planning process, commanders must consider these environmental factors and attempt to use either the environment in their favor or negate its effects as much as possible.

a. Weather and Visibility. Weather and visibility create advantages and disadvantages for opposing forces. To fight effectively, commanders must know how they are limited by poor weather and visibility. At times, the ATKHB may not be able to execute a mission because of the weather. Therefore, the ATKHB commander must advise the force commander of the restrictions that bad weather and visibility place on the ATKHB.

(1) Weather. Weather affects soldiers, equipment, operations, and terrain. Cloud cover, wind, rain, snow, fog, dust, light conditions, and temperature extremes combine in various ways to affect human efficiency and limit the use of weapons and equipment. ATKHB assets are greatly influenced by the effects of weather, but so are enemy assets. Rain can degrade the FLIR systems used on AH-64s and OH-58Ds for piloting the aircraft and targeting. However, rain also inhibits the cross-country maneuverability of enemy mechanized forces, causing their movement to slow or channelize on roads. High winds makes gunnery for attack helicopters more difficult, but it also makes enemy obscurants less effective. Each system used on the battlefield has its strong and weak points in relation to the environment. Commanders must know the strengths of each system and use them to attack the weaknesses of enemy systems.

(2) Visibility. Limited visibility affects operations and favors the attacker by masking his maneuver. However, darkness, fog, and smoke reduce the useful ranges of most weapons, including enemy AD weapons. During periods of limited visibility, attack helicopters must maneuver closer to the enemy for successful engagements. The winner of an engagement will usually be the soldier or aircrew that gains surprise, acquires the target, and accurately fires the fastest. ATKHC commanders must maneuver their forces to a positional advantage using the terrain and concealment afforded by the limited-visibility environment. Once in position, crew members will have to acquire the target, fire rapidly, and then move. At close range, any delay in effectively engaging the enemy and repositioning gives the enemy time to react and return fire.

b. Terrain. "Geography and ground can affect military operations in three ways--as an obstacle to the approach, as an impediment to visibility, and as cover from fire." Clausewitz, On War.

(1) **Analysis.** Terrain analysis is a critical skill; all members of the ATKHB must develop an understanding of the limitations and opportunities that terrain affords. ATKHB commanders and their staffs perform terrain analysis in light of their units' missions. Whether using the advanced capabilities of the AMPS and ASAS or paper maps, they evaluate the terrain's potential for cover and concealment, its impact on their maneuver and the enemy's movements, and its use for observation and direct fire effect. The key elements of terrain analysis are summarized in the mnemonic OCOKA--

- (a) Observation and fields of fire.
- (b) Cover and concealment.
- (c) Obstacles to movement.
- (d) Key terrain.
- (e) Avenues of approach.

(2) **Reinforcement.** The proper use of natural obstacles and the reinforcement of terrain must be an integral part of the ATKHB commander's plan. Artillery fires, direct fire EAs, and obstacles must all be combined in the tactical plan. Engineers use obstacles to disrupt, fix, turn, or block the enemy. Disruptive obstacles cause enemy formations to separate or bunch up, which disrupts their maneuver and attack. Fixing obstacles slow enemy progress and allow friendly artillery and direct fires the opportunity to mass. Turning obstacles drive the enemy toward friendly EAs and massed fires or force them to expose their flanks, allowing friendly gunners to achieve a positional advantage. Blocking obstacles deny the enemy access to a given area or prevent his advance in a given direction. Although the ATKHB will seldom have engineer support to establish obstacles, the ATKHB commander must understand the force commander's obstacle plan and use it to the battalion's advantage.

(3) **Intelligence.** The commander must be familiar with the terrain before combat. Because maps are sometimes inaccurate or incomplete, commanders should conduct a detailed, personal reconnaissance. Company commanders should ensure that their aircrews are familiar with the terrain and scheme of maneuver. If possible, crews should visit battle and firing positions, perform a map reconnaissance, and conduct sand table exercises before executing a mission. These actions will help them to understand the scheme of maneuver, commander's intent, and terrain and quicken their reactions during the chaos of battle. All sources of intelligence must be considered. Aerial photographs, satellite imagery, HUMINT, SIGINT, and ELINT can each be critical assets.

c. **Special Environments.** The ATKHB operates best over open, rolling terrain, which is also favored by mechanized forces. It is least effective against enemy forces that are stationary, well-camouflaged, and in prepared positions. The ATKHB will be called upon to execute its mission in a variety of environments. The following paragraphs cover specialized environments in which the ATKHB may be expected to operate.

(1) Urbanized terrain.

(a) Commanders can employ attack helicopters in urban terrain. However, there are special planning considerations for this type of employment. In urban areas, fields of fire are restricted and buildings provide cover for enemy light forces to engage attack helicopters with near impunity. This type of terrain can negate the effectiveness of the long-range, precision munitions of the attack helicopter. Rockets and cannons can be used against light structures; however, they may not have sufficient explosive power to be used against well-constructed buildings of reinforced brick and concrete. While there are challenges for commanders employing attack helicopters in urban environments, experience has shown that attack helicopters are much more effective and flexible than mortars and artillery in urban operations.

(b) The ATKHB is well-suited for employment on the outskirts of an urban area, attacking forces that are attempting to bypass, envelop, or reinforce the built-up area. If employed in urban terrain, special consideration should be given to the munitions selected. Collateral damage near targets engaged by Hellfire ATGMs will be higher than near those engaged by 30 mm TP rounds. Consideration should also be given to high-energy, high-altitude tactics, such as diving fire, to overcome the vertical restrictions of built-up terrain. For planning, the commander must keep in mind the following challenges of MOUT:

- Flight routes in urbanized terrain may increase employment times and fuel consumption.
- Buildings limit maneuverability and engagement range, as do mountains.
- Urbanized terrain may limit FARP size, location and response times.
- Extensive urban sprawl and high buildings degrade communications and may require extensive relay and retransmission sites.
- Urbanized terrain masks IEW acquisition capabilities.
- The numerous buildings and streets and few map references complicate navigation in built-up areas.
- Urban areas directly affect weather, especially wind patterns.
- Landing and pickup zones may be severely limited; operations from rooftops may be required.

(2) Mountains. Mountainous areas provide unique challenges for attack helicopters. While high altitude limits the load-carrying capability of the attack helicopter, the terrain is compartmentalized, allowing for rapid movement to the flanks and rear of an isolated enemy force. Enemy mechanized forces will be slowed and

FM 1-112

channelized as they move up steep grades and down narrow valleys or are restricted to roads and trails. Mountains provide excellent terrain-masking and allow easy avoidance of radar and visual acquisition. However, high ridges also provide effective firing positions for AD guns and hand-held missiles. The nature of the terrain and the distances that must be traversed to get into position to attack may require that the ATKHB engage the enemy force without the support of other combined arms.

(3) Jungles. Dense jungles and wooded areas severely limit the capability of the ATKHB to effectively employ precision-guided munitions. Heavily wooded areas degrade fields of fire and target identification. Although the capability of the ATKHB to employ precision-guided munitions is degraded, it can still provide supporting fires for other members of the combined arms team. Attack helicopters can carry large loads of nonprecision guided munitions, such as rockets and cannon. When directed by scouts or ground forces, they can place heavy fires on the enemy. These fires can suppress the enemy, block his withdrawal, or destroy massed light forces. ATKHB fires should be maximized against enemy targets that oppose the friendly main effort. Some things to remember when operating in a jungle environment include the following:

- (a)** Aircraft should not overfly the target.
- (b)** Humid tropical air decreases aircraft lift capabilities, decreasing payload.
- (c)** Thunderstorms can cause rapid and violent changes in the weather.
- (d)** Attacks should be made simultaneously from more than one direction to confuse the enemy.
- (e)** Attacks should be made along the length of the enemy force, not perpendicular to it.
- (f)** The location of friendly forces should be marked and easily identified from the air.
- (g)** Constant communications and liaison are needed between the attacking ATKHB and the element of the supported ground force in contact.
- (h)** Attacks should not be made over the heads of friendly ground forces. (Expended shells falling from the attack aircraft may cause confusion among friendly troops, leading to possible fratricide. This is true for all types of terrain.)

(4) Deserts. The ATKHB can effectively operate in the desert or in open terrain. However, it is vulnerable to enemy long-range observation, acquisition, and harsh environmental conditions. Shifting sand dunes make maps obsolete quickly, and the lack of any NAVAIDS, man-made or natural, make navigation extremely difficult without GPS or Doppler navigation assistance. Heat limits weapon and fuel loads that

each attack aircraft can carry, and sand and dust can cause damage and increased maintenance requirement for the aircraft. Attack aircraft flying low and slow may produce large dust clouds. Clouds of dust are easily detected and obscure aircraft acquisition systems. These severe conditions require proper maintenance, engagement techniques, and positioning of Class III/V resources. Extra maintenance will help correct the problems of heat, sand, and dust. Both air and ground crews must be aware that engines have to be cleaned and filters changed more often during desert operations. Firing while flying above ETL airspeed diminishes the dust signature and aids in survivability. The loss of load capabilities is overcome by placing FARPs closer to the objective areas. When operating above ETL, attack aircraft can operate at higher gross weights than when hovering fire is used.

d. NBC Weapons.

(1) Because of the world-wide proliferation of NBC weapons since the end of the Cold War, potential enemies of the United States may be expected to use NBC weapons. Weapons of mass destruction may be the enemy's alternative to conventional warfare. Nuclear and chemical weapons could have a devastating effect if friendly forces are unprepared for their use.

(2) The ATKHB commander must take the exposure guidance of his higher headquarters, the enemy's intent and capability, and the mission and condition of the unit into account when setting the battalion mission oriented protective posture level. If the enemy can use or has used chemical weapons anywhere on the battlefield, commanders must immediately take precautionary measures to protect their battalions. This will normally mean that the ATKHB will conduct operations in MOPP 2 before chemical weapons are used and go to MOPP 4 when their use is imminent or after they are used. The ATKHB will survive by anticipating nuclear or chemical attacks. To avoid becoming lucrative targets, commanders must--

- (a)** Avoid detection.
- (b)** Retain mobility.
- (c)** Plan for rapid reorganization and be prepared to continue operations.
- (d)** Seek terrain shielding by carefully selecting assembly areas and preparing shelters/fighting positions.
- (e)** Be aware of flying debris in a nuclear environment.
- (f)** Be alert to the possibility of a nuclear or chemical attack and adjust the MOPP level and unit dispersion according to the threat.

(g) Instill discipline and physical conditioning to prepare troops for the confusion and physical demands of a nuclear/chemical environment.

e. **EW.** EW is an essential element of combat power. Its contribution lies in exploiting enemy weaknesses, protecting friendly freedom of action, and reducing security and communication vulnerabilities. Modern military forces depend on electronics for C² of forces and employment of weapon systems. Friendly and enemy forces are vulnerable to actions that can reduce the effectiveness of their electronics. Properly applied EW can locate, identify, target, deceive, delay, disorganize, and destroy the enemy when integrated into the overall concept of the operation. FMs 34-1, 34-7, and 34-10 provide detailed information on EW.

(1) **ES.** ES involves actions to intercept, locate, and identify threat sources. ES provides combat information for the S2 to meet the commander's IR/PIR. The S2, following the commander's guidance, must establish priorities for ES orders and requests, continuously update ongoing ES operations, and anticipate future ES operations by tasking organic ES assets and coordinating with the IEW support element within the ACE.

(2) **EA.** EA involves actions taken to prevent or reduce the use of the electromagnetic spectrum by hostile forces. The aviation S3 has staff responsibility for overall planning and coordination of EW operations. He primarily directs the EA in jamming and deception roles. With the S2, FSO, and IEW support element, the S3 will establish priorities for targets. EA is directed against targets to degrade the enemy's ability to respond quickly and effectively.

(3) **EP.** EP involves actions taken to retain friendly use of the electromagnetic spectrum. The S3 will coordinate with the signal officer to establish EP to protect friendly signal operations. Training in the correct employment of the signal emitters and emitter capabilities and design is necessary for successful EP. Equally important is training in the correct use of Signal Operating Instructions, communications discipline, and proper radio/telephone operating procedures.

f. Smoke and Obscurants.

(1) Smoke and obscurants are integral to the former-Soviet Union's doctrine, tactics, equipment, and training. The threat will use smoke to increase its effectiveness and reduce its vulnerability. Specifically, smoke can--

- (a) Deny information.
- (b) Mask the use of chemical weapons.
- (c) Disrupt movement, operations, and C².
- (d) Restrict NOE and contour approaches to EAs.

(e) Reduce the effectiveness of sensors, range finders, and target designators.

(2) The ATKHB can also use smoke to enhance its survivability. Through the use of artillery-fired smoke or 2.75-inch FFAR white phosphorus rounds, the ATKHB can achieve the same results as the enemy. Additional benefits of the use of smoke by ATKHBs are--

(a) To suppress visually sighted enemy ADA systems and small arms.

(b) To sector portions of the EAs, isolating part of the enemy force.

(c) To screen the displacement of the ATKHCs while they move to new firing or BPs or break contact.

g. Battlefield Stress.

(1) As they plan and conduct operations, commanders must remember the effects of combat stress and minimize adverse consequences. While ground forces will carry the brunt of the fighting, the enemy's main effort will not always affect the same units. Because the ATKHB can maneuver quickly and mass combat power at the critical time and place, it can expect to engage in direct combat more often than other maneuver units. Therefore, minimizing the adverse effects of battlefield stress is an important factor in ATKHB combat effectiveness.

(2) The adverse effects of battlefield stress may occur as--

(a) Physical and mental fatigue from sleep loss.

(b) Continual physical/mental effort under high work load and time pressures.

(c) Physiological stress from extreme temperatures; noise; vibration; blasts, flashes and radiation; battlefield air pollution; all degrees of effects from chemical weapons and their antidotes; and other-than-fatigue effects from the factors listed above.

(d) A generally incapacitating, long-term (days, months, or sometimes years) psychological stress casualty syndrome (combat fatigue).

(e) Transient, severe degradation or breakdowns in mental capabilities (and physical capabilities under some extreme situations) during the extreme fear of actual combat and anticipation of actual combat.

(3) A combination of all these effects exists in some degree (usually a substantial degree) in every individual in every combat situation. This combination of stress effects will initially reduce the combat effectiveness of individuals and units below

FM 1-112

that demonstrated during peacetime training. As their combat experience increases, most individuals will learn to cope with the adverse effects of battlefield stress on their combat performance. However, even a combat-experienced unit's performance can be expected to remain below that demonstrated during peacetime training.

(4) Leaders at all levels must be able to recognize the signs of fatigue and battlefield stress. Fatigue and battlefield stress will cause noncombat-related accidents that will diminish the combat power of the ATKHB, risking lives, aircraft, and a highly trained crew. Fatigue can be controlled through rest; aircrews that fight all day cannot expect to fight well all night. Prompt treatment of stress casualties in forward areas can return most soldiers to duty rapidly. Both ATKHB and ATKHC commanders must make a realistic evaluation of the condition of their soldiers and then make recommendations to the force commander about their capability to continue the fight.

Section IV. Movement to the Objective Area

3-6. PREPARATION FOR MOVEMENT

a. **General.** Fighting the battle involves taking the plan that has been formulated and shaping it to fit the situation. To plan the battle, the ATKHC commander selects routes, flight modes, and platoon BPs; coordinates fire control measures; devises a plan that considers the factors of METT-T; and accomplishes the mission. The ATKHC commander's plan must be flexible enough to allow for rapid deviation to meet the actual situation. When deciding his courses of action, the ATKHC commander must consider the mission, threat, movement, occupation of the BP, actions in the BP, egress and restoration. He must also consider when to begin the engagement and when to maneuver.

(1) **Mission.** The mission of the ATKHC is a subset of the mission assigned to the ATKHB. The success or failure of the ATKHC directly relates to the success or failure of its companies. ATKHC commanders use the ATKHB commander's intent and mission statement to decide how to accomplish the company's mission. However, it is possible that the ATKHC will have a mission that is different from that of the battalion. An example is an ATKHC that is supporting the attack of its parent battalion. The ATKHB has the mission to disrupt an enemy TR, and one of the ATKHCs has the mission to screen in the ATKHB's sector.

(2) **Threat.** Just as the ATKHB conducts an IPB during planning, so must the ATKHC. The ATKHC IPB is based upon the IPB that is prepared by the ATKHB, and is oriented toward confirming the battalion's IPB. It involves plotting the routes through the EA where groups of vehicles will maneuver and determining the location of priority targets and AD systems. With this information, the ATKHC commander will be better prepared to select BPs for his platoons or teams and designate their sectors of fire.

b. Precombat Checks.

(1) Commanders conduct precombat checks to ensure the unit is prepared for the mission. Aircrews and aircraft require extensive precombat checks to ensure mission readiness.

(2) Precombat checks are a part of all missions and are included in this manual to increase the probability of successful completion of all operations. The following paragraphs contain a suggested format for the aircrew precombat checks.

c. Before Mission Receipt Checks.

(1) Aircraft should be preflighted per appropriate checklist with PPC in progress. Aircraft logbook should be in a known location, preferably in the aircraft.

(2) Aircraft should be full of fuel and loaded with ammunition (if applicable). Weight and balance should be computed for aircraft load.

(3) Aircrew on appropriate crew rest schedule should be tracked by commander and ASO.

d. Upon Mission Receipt. The commander and company planners provide the following information. This information is gathered from the various unit staff sections:

***(1)** Assessment of the enemy capability.

***(2)** Mission graphics.

(3) Navigation/air route planning according to posted A²C² plan.

(4) FS and fire distribution on the objective.

***(5)** Actions on contact.

***(6)** Communication card or SOIs.

***(7)** COMSEC/IFF codes for aircraft.

***(8)** Weather, light data, and fuel requirements

(9) Tactical FPLN preparation and filing.

(10) Risk assessment.

FM 1-112

***NOTE:** Much of this information may be developed concurrently with the staff. The items marked with the asterisk contain information that can be continuously tracked and updated prior to mission receipt.

e. Preparing for the Mission. Following receipt of the mission briefing (either written or oral), the ATKHC executes the following:

(1) The commander conducts a briefing to cover more detailed flight and tactical procedures for the mission aircrews. A mission briefing format can be found in Appendix C.

(2) The company planners receive updates from the staff, continuously updating the friendly and enemy situation, as well as weather and environmental considerations.

(3) By backward planning from the EA to the assembly area, the commander and company planners determine the mission's time sequence.

(4) A FPLN or field strip is filed at flight operations with a current risk assessment for the mission.

f. Final Checks. Before the crews move to the aircraft, the following checks should take place:

(1) **Graphics.** The commander or a designated platoon leader should inspect the mission graphics of the mission crews for completeness and accuracy. Use a known, properly prepared map as a baseline. This technique can be ongoing through the planning process, but a quick check prior to the mission is critical.

(2) **Communication card.** If the crews had to copy their own frequencies and call signs, designate a crew member to read the card aloud to the crews to check accuracy. Ensure crews know the proper frequencies for conduct of communication check.

(3) **Mission statement and commander's intent.** The commander will read the mission statement and the commander's intent to the crews.

(4) **Chain of command.** Restate the chain of command and reiterate the downed pilot points and the SERE plan. Ask for questions, and send the crews to their aircraft.

g. Crew Checks. Crews should check the following items before getting into the aircraft:

(1) Crew members within limits of crew endurance policy.

(2) Aircraft ignition key is present.

- (3) ALSE, both personal and crew, present.
- (4) Checklist, -10 manual, and all mission-related publications available.
- (5) At least one canteen and one MRE available per crew member.
- (6) Special mission equipment (such as NVGs and sidearms) available and function check complete.
- (7) COMSEC and IFF codes loaded in appropriate equipment.

h. Run-Up Checks.

- (1) Crews must complete start sequence according to the appropriate -10 checklist.
- (2) Crews must complete weapons system initialization according to the appropriate aircraft aircrew training manual. For armed helicopters, weapons checks and boresights are considered one of the most critical precombat checks.

i. Communications Check. The communication check described below may not be compatible with all communications packages in armed helicopters. The commander may use this technique for SOP development.

- (1) Chalk 1 starts the check on FM, selects UHF and transmits, and then selects VHF and transmits. For example, "This is (call sign) on 1 (FM internal frequency nonsecure), 2 (UHF internal frequency), and 3 (VHF internal frequency)."
- (2) This process continues through the chalk order until all aircraft in the flight have checked. All aircraft will monitor to determine which radios work on which aircraft.
- (3) Chalk 1 announces "This is (call sign), go secure on 1." This instructs the flight to select the secure mode for their FM radio. The check progresses as (1) above, but only the FM is used.
- (4) Once FM secure is checked, the flight can go active on Have Quick, with a designated aircraft in the flight sending the time.
 - (a) If crews use this procedure during all training missions, communication checks become quick and routine. The commander may need to readjust radio nets due to nonfunctioning radios in the flight. It is very important to let all crews know which radios the nets are on before takeoff.
 - (b) Once all checks are complete and the commander is satisfied the flight can communicate, he will call "execute card." This will tell the crews to tune their

radios to the predetermined nets for the mission, and will most likely be the last radio transmission until takeoff.

j. Conclusion. When the commander or AMC calls for takeoff, he must assume that the crews in his flight have conducted all weapons systems checks. Units must practice precombat checks prior to all training missions. When practiced regularly, these checks will become routine and easily accomplished.

3-7. MOVEMENT

a. Principles of Overwatch. ATKHCs maneuver to fight the enemy in much the same way as mechanized maneuver forces. The major difference is that terrain does not hinder helicopter movement. The maneuvering force's use of terrain as an ally applies equally to both ground vehicles and attack helicopters. Therefore, the ATKHC must adapt its flight mode and technique of movement to maintain security. The principles of overwatch that apply to attack helicopter units are discussed below.

(1) Find the enemy with a minimum of forces. Scouts move ahead of attack elements to assist in locating the enemy and reconnoiter the BP. During the move, scouts should provide rear security and reconnoiter frequently to locate enemy ground and air threats.

(2) Use all available cover and concealment. The ATKHC must use stealth to maneuver into position to engage the enemy. The use of the surrounding terrain and vegetation will allow the company to arrive undetected at the BP.

(3) Overwatch lead elements and be prepared to fire and maneuver. This principle applies when the company approaches a BP, attacks in sector, or takes part in an exploitation or a pursuit. The battlefield has no secure positions.

(4) Adjust the movement technique and type of terrain flight to the factors of METT-T. The ATKHC will use traveling, traveling overwatch, or bounding overwatch techniques depending on the likelihood of enemy contact. Low-level, contour, or NOE flight will be used as appropriate.

b. Movement Techniques.

(1) Traveling. Traveling is used when speed is important and contact with the enemy is not likely. Traveling is used to move rapidly in relatively secure areas; for example, in a corps or division rear area. The ATKHC can use traveling with both platoons in one flight or separate platoons in multiple flights. In either case, the company moves at a constant airspeed using the appropriate type of terrain flight.

(2) Traveling overwatch. Traveling overwatch is used when enemy contact is possible. Precautionary measures are justified, but speed is desirable. The ATKHC leads with its light platoon, which moves at a constant rate; the heavy platoon

trails and moves as necessary to provide overwatch of the light platoon. The overwatching platoon observes the terrain where the enemy might be positioned to fire on the lead platoon.

(3) Bounding overwatch. Bounding overwatch is used when enemy contact is expected. From a covered, concealed position, the overwatching platoon monitors the progress of the bounding platoon. Each platoon may bound or overwatch in turn; however, the movement may also be executed with the light platoon always bounding and the heavy platoon always overwatching. The overwatch position should offer observation and fields of fire against potential enemy positions. Table 3-1 lists the techniques of movement, and Figure 3-13 shows the techniques of movement in relation to the battlefield.

Table 3-1. Techniques of movement

| Technique | Contact | Terrain Flight |
|---------------------|------------|----------------------|
| Traveling | Not likely | Low-level or contour |
| Traveling overwatch | Possible | Contour or NOE |
| Bounding overwatch | Expected | NOE |

c. Axis of Advance. The effective movement of ATKHCs throughout the battlefield is one of the keys to mission success. The ATKHB uses an axis of advance, a general direction of movement, which is divided into routes for each ATKHC, between the FAA and the battalion sector. It is planned and plotted to correspond with the A²C² plan, avoid known enemy concentrations, and take advantage of the terrain. The ATKHC routes within the axis are wide enough to allow for maneuver (approximately 1 kilometer wide or 500 meters either side of the centerline). Each company route is 4 to 5 kilometers apart (centerline to centerline) and uses the standard control measures of an LD or SP, ACP, and RP. The SPs, ACPs, and RPs are located along the centerline to orient the ATKHCs as they maneuver toward their sectors and HAs. Figure 3-14 shows three separate routes (one for each company). A²C² is discussed in-depth in FMs 100-103 and 1-111.

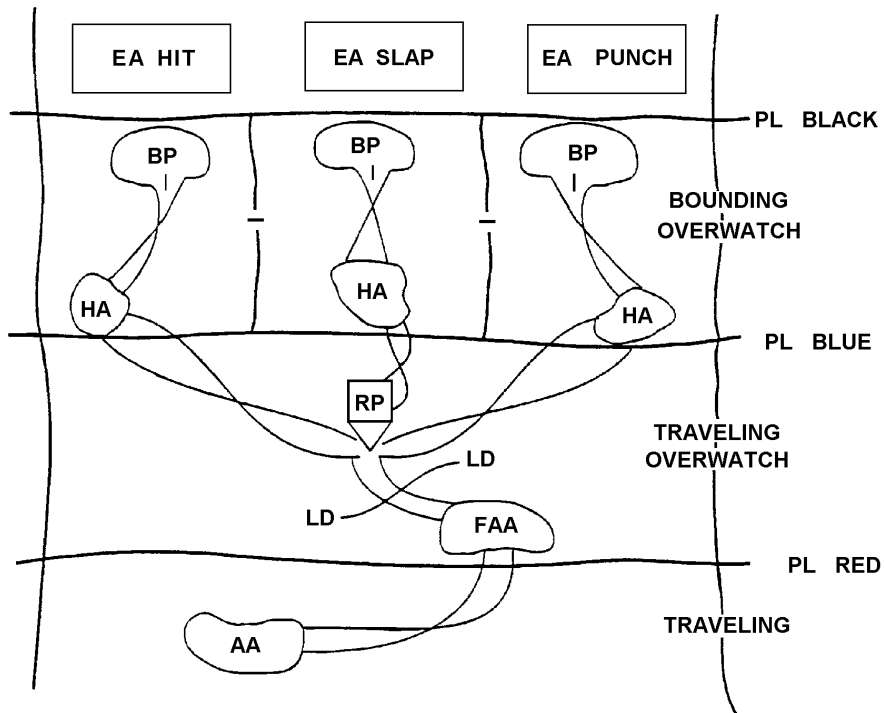

Figure 3-13. Techniques of movement on the battlefield

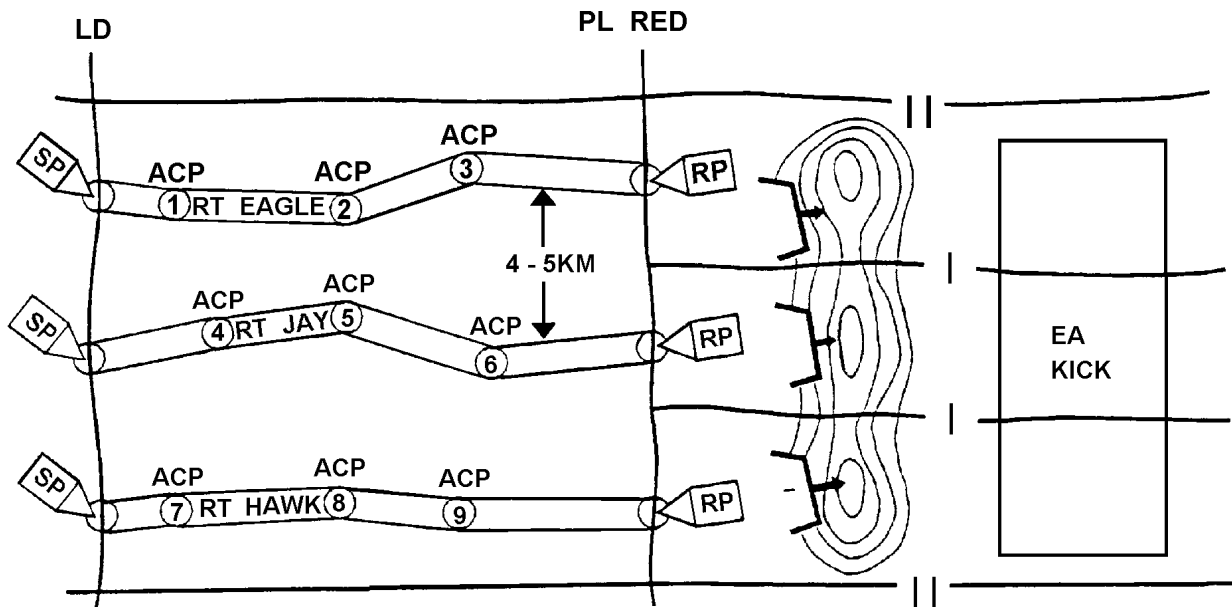

Figure 3-14. ATKHB axis of advance broken down into company routes

d. **Multihelicopter Operations.** Commanders designate formations for the company to establish the relationship of one platoon to another in the air, establish the concept of where the enemy will be and how the company will react to contact, and establish the degree of security desired. The basic attack aviation tactical unit is the two-aircraft, L/W team.

(1) **L/W team movement.** Three team techniques of movement are **free cruise**, **combat cruise**, and **combat spread**. These techniques are designed to provide team security and flexibility, and they are the building blocks of platoon and company formations. In each case, the lead aircraft designates the primary direction of travel and the wingman maintains his position in relation to the lead aircraft. The general rule for the L/W relationship is "follow me and do as I do". Teams are purposely spread out; a spread-out team allows the wingman to spend most of his effort searching for threats and less time watching the lead aircraft.

(a) **Free cruise.** Free cruise is used when teams desire to move quickly and maximize the use of terrain for masking. It gives the team freedom to maneuver and allows the wingman to provide security for his lead. Free cruise permits the wingman to maneuver in the zone extending 45 degrees on either side and to the rear of the leader's tail. The wingman should avoid the area directly behind the lead (6 o'clock position) because of his inability to provide suppressive fires for lead, his limited forward observation, and the possibility that his lead's presence alerted the enemy in his flight path. Figure 3-15 shows an example of a free cruise formation.

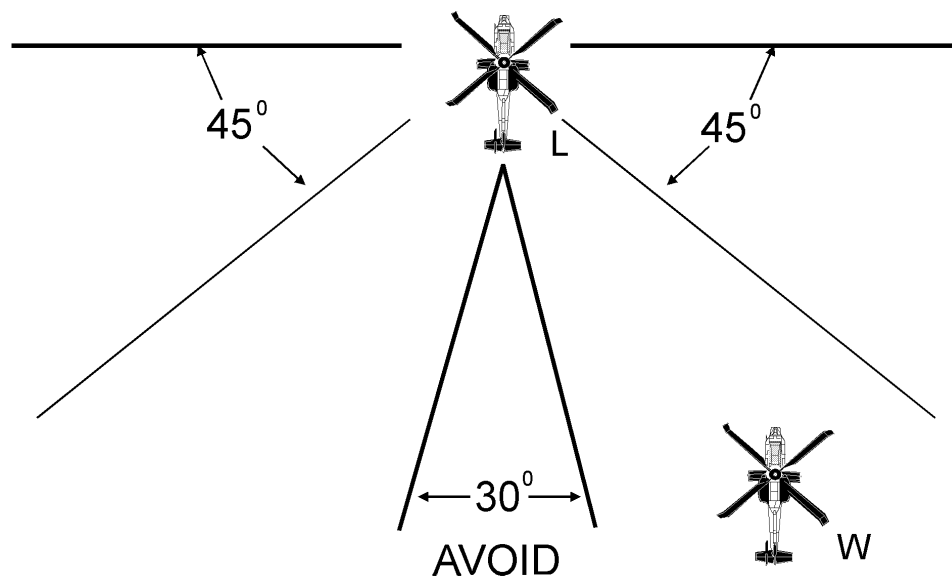

Figure 3-15. Example of a free cruise formation

(b) **Combat cruise.** Unlike free cruise, combat cruise requires the wingman to remain in either right or left cruise and change sides only after being directed to do so by the lead aircraft or after he communicates to the lead aircraft his intentions to change sides. Using combat cruise, the wingman should fly an arc from 10 to 75 degrees aft the lead aircraft (right cruise) or the same approximate location on the other side of the lead aircraft (left cruise). The optimum position for the wingman is 45 degrees aft the lead aircraft. For planning, the wingman should maintain an approximately 10-rotor diameter (rotor tip to rotor tip) separation from his lead. The wingman should avoid the area directly behind the lead, as in free cruise. Figure 3-16 shows an example of a combat cruise formation.

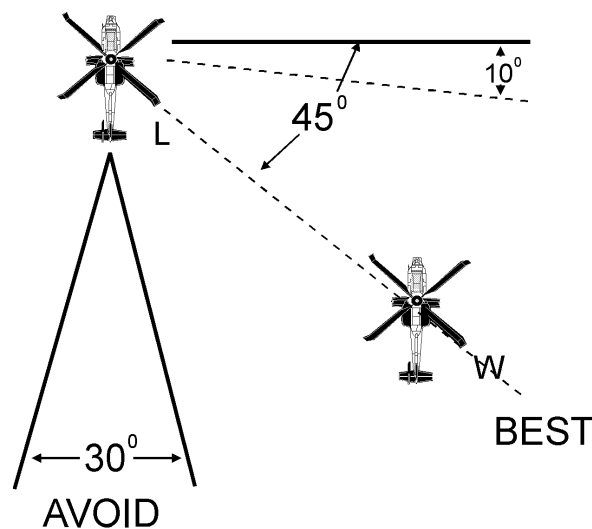

Figure 3-16. Example of a combat-cruise formation

(c) **Combat spread.** The combat-spread is used when enemy contact is imminent. This formation promotes security by providing maximum firepower forward and overlapping fields of view. It is flown with the wingman in a plus or minus 10-degree abeam position on either the left or right side (spread left or spread right) of the lead aircraft. For planning, the wingman should maintain an approximately 10-rotor diameter (rotor tip to rotor tip) separation from his lead. Commanders may vary the maximum lateral separation between aircraft based on visibility, maneuver space available, and expected enemy weapon ranges. Figure 3-17 shows an example of a combat-spread formation.

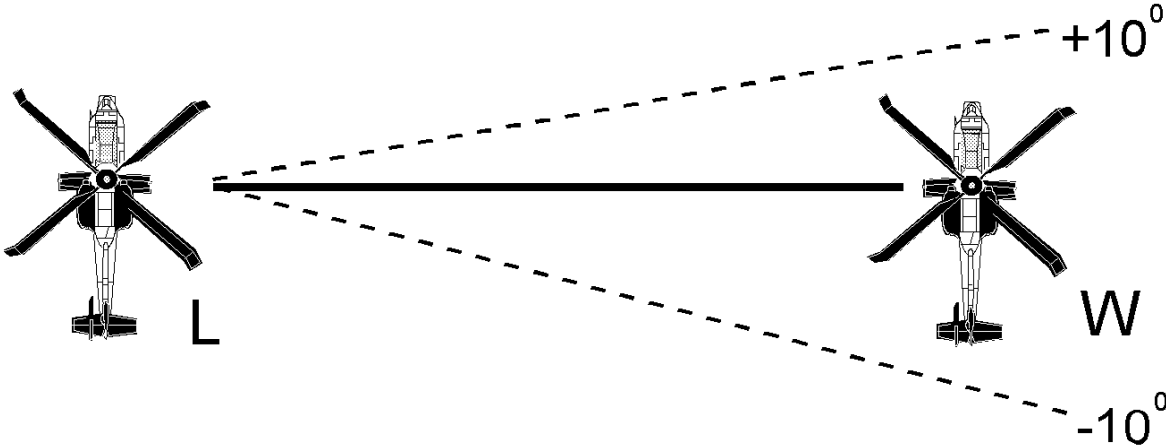

Figure 3-17. Example of a combat-spread formation

(d) **Line formation.** A variation on the combat-spread is the line formation. It may be used to facilitate movement into BPs, SBF positions, and ABF positions. The line formation is formed by placing two teams using the combat-spread formation side-by-side. This technique is also known as "stacking right" or "stacking left." The line formation has advantages. It provides excellent firepower forward. It provides a wide area of protection to ground elements if used during an overwatch. It also allows the maximum number of helicopters to close on an objective in the shortest time. The line formation has disadvantages. It provides minimum fires to flanks. It is less secure than regular combat spreads because of the lack of depth. It is more difficult to control than team combat spreads. It also decreases freedom of maneuver. An example of a line formation is shown in Figure 3-18.

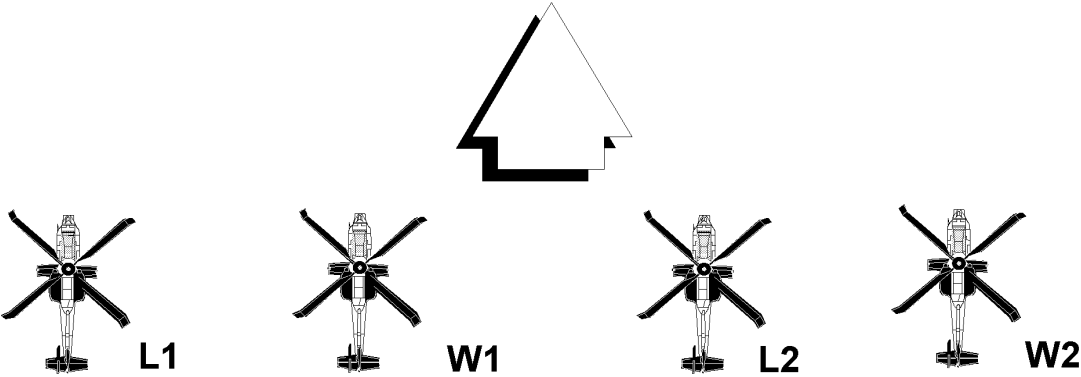

Figure 3-18. Example of a line formation

(3) Platoon/company formations.

(a) There is normally little tactical advantage for using tight, rigid formations for attack helicopters. Commanders lose their maneuver advantage, and they may jeopardize weapons effectiveness by trying to maintain tight formations during terrain flight near the objective area. In addition, a team's ability to properly execute actions on contact is contingent upon maneuver space and may be significantly hindered by helicopters flying too closely.

(b) Platoon and company formations are built from L/W teams. The commander does not normally employ rigid formations, but he does employ techniques such as travelling overwatch or bounding overwatch during contour and NOE flight. However, the commander may choose to employ the formations listed in the paragraph below during low-level flight or during nonterrain flight modes, based on METT-T. These formations are normally used when enemy contact is not expected, speed of movement is desired, or to cross a specific point quickly (for example, a FLOT passage point).

e. Tactical Formations. The following are example formations for attack helicopter platoons and companies. When using these formations, the commander should plan to separate teams by no less than approximately 10 rotor diameters (rotor tip to rotor tip). Individual aircraft should move in the same relative position within the formation. This will ensure that each crew knows where to move, who is behind them, and where to observe and direct fires. The four basic formations are staggered column, wedge, combat trail, and echelon.

(1) Staggered. The staggered column is normally the formation of choice for movement in the attack helicopter platoon and company. This formation allows team integrity, while maintaining separation between elements. The staggered column is used as a general purpose travelling and travelling overwatch formation when the terrain allows for dispersion and allows the commander to array his aircraft to the left or right of the lead aircraft, also known as "staggered right" and "staggered left". (**NOTE:** Staggered right is particularly well-suited for AH-64s conducting night system flight. It allows the pilot's unaided (left) eye to watch the lead aircraft's position lights while the aided (right) eye focuses on the night system display.)

(a) The staggered column formation has advantages. It provides excellent control. It provides excellent firepower to the flanks. It facilitates rapid deployment to other formations. It also facilitates rapid movement. The dispersion and depth increases security against enemy air and ground attacks.

(b) The staggered column formation has disadvantages. It provides limited firepower forward. C² is difficult as the formation elongates.

(c) An example of a staggered formation is shown in Figure 3-19.

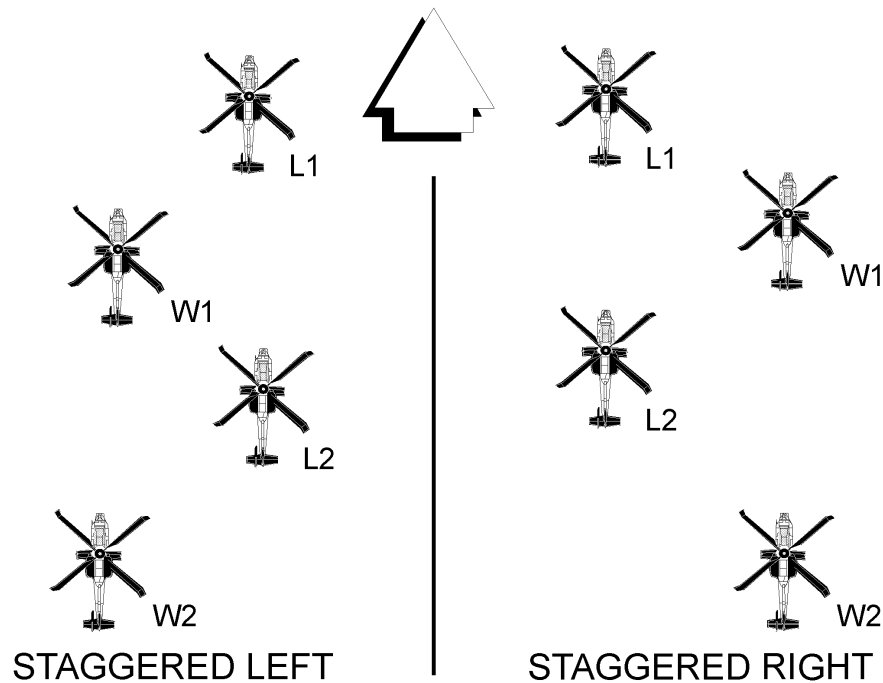

Figure 3-19. Example of a staggered formation

(2) Wedge. The wedge formation may be used when a platoon or company is providing overwatch for another element (for example, acting as an advanced guard for an air movement) and the terrain is open or rolling. The wedge formation is formed by two combat-cruise formations (a left cruise on the left and a right cruise on the right).

(a) The wedge has advantages. It permits excellent fire to the front and good fire to each flank when leading ground maneuver formations, other aviation elements, and convoys. It allows the platoon leader excellent observation up front while being covered by a wingman.

(b) The wedge has disadvantages. It requires lateral space for movement; therefore, it is difficult to use in closed terrain. It may expose the entire platoon to enemy fire simultaneously.

(c) An example of a wedge formation is shown in Figure 3-20.

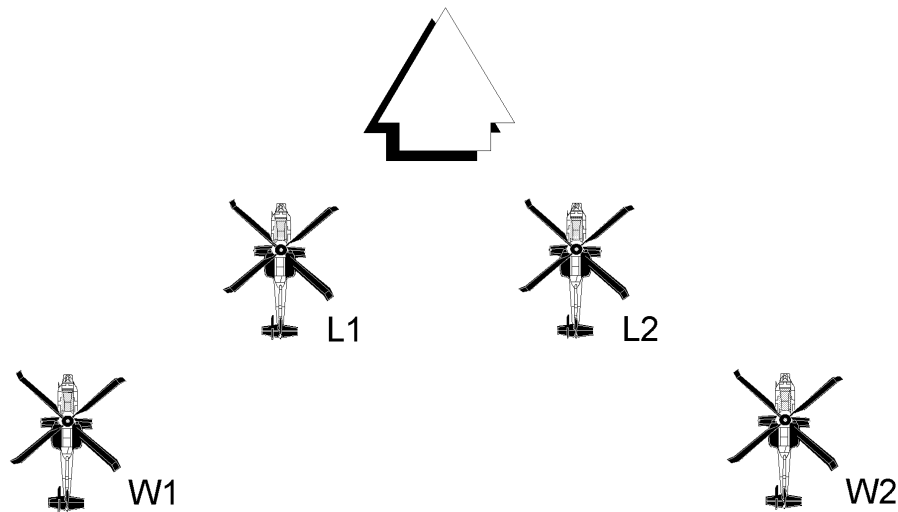

Figure 3-20. Example of a wedge formation

(3) Combat trail. The combat trail formation is used most often when passing through defiles or close terrain, during air movements, and during movements when speed is required. The combat trail formation is formed by two free-cruise formations (one behind the other).

(a) The combat trail formation has advantages. It provides good C^2 and speed when closing a large number of helicopters on an objective in a short period of time. It allows rapid movement through rugged, closed terrain. It provides ample maneuver room for actions on contact. It also is less fatiguing to crews because they do not have to concentrate on rigid aircraft orientation, particularly in poor weather.

(b) The combat trail has disadvantages. It provides minimal firepower forward. It is less secure than other formations because of the lack of depth. It may cause disorientation during night flights due to the lack of depth of field in NVDs. In addition, this is a very difficult formation to maintain during night landings because rate of closure is difficult to judge.

(c) An example of a combat trail formation is shown in Figure 3-21.

(4) Echelon. The echelon formation is normally used during travelling overwatch, when speed is required. The echelon formation allows the platoon leader to array his aircraft to the left or right of the lead aircraft. Normally, the platoon leader and his wingman lead, followed by the team leader and wingman. This formation is used in situations the tactical situation does not favor a trail formation, and firepower must be focused forward.

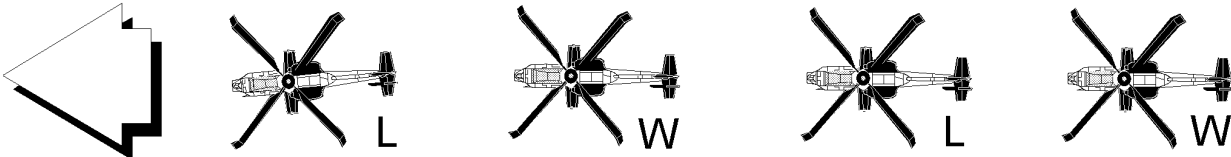

Figure 3-21. Example of a combat trail formation

(a) The echelon formation has advantages. It provides excellent fires to the front. It allows the speed of a combat trail formation with a wider front. It also facilitates rapid deployment to other formations.

(b) The echelon formation has disadvantages. It limits fires to the front. It is more difficult to maintain orientation than in a combat trail. It also provides less control in restricted terrain.

(c) An example of an echelon formation is shown in Figure 3-22.

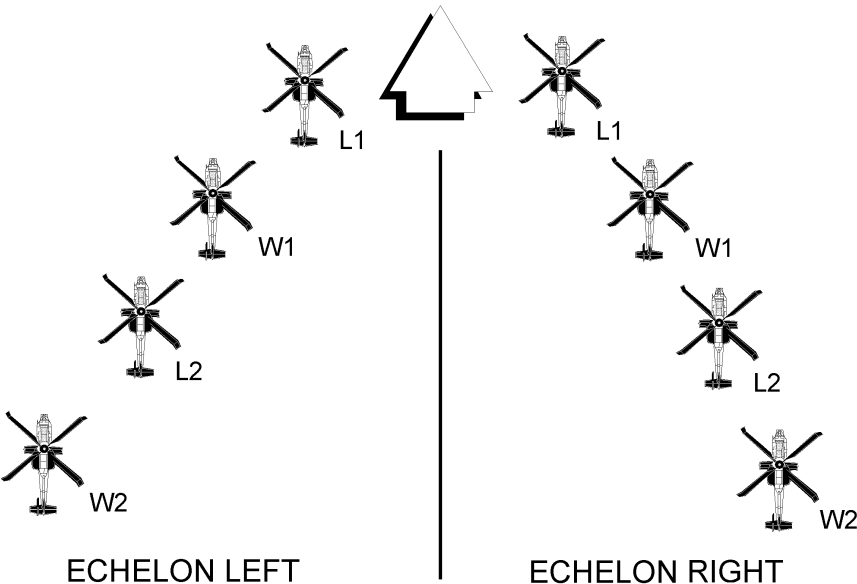

Figure 3-22. Example of an echelon formation

(d) ATKHC commanders may use a combination of formations to maneuver his company, mixing techniques between platoons or teams, based on METT-T. As an example of mixed formations, Figure 3-23 shows a heavy platoon using a wedge formation and a light platoon using the combat-spread formation.

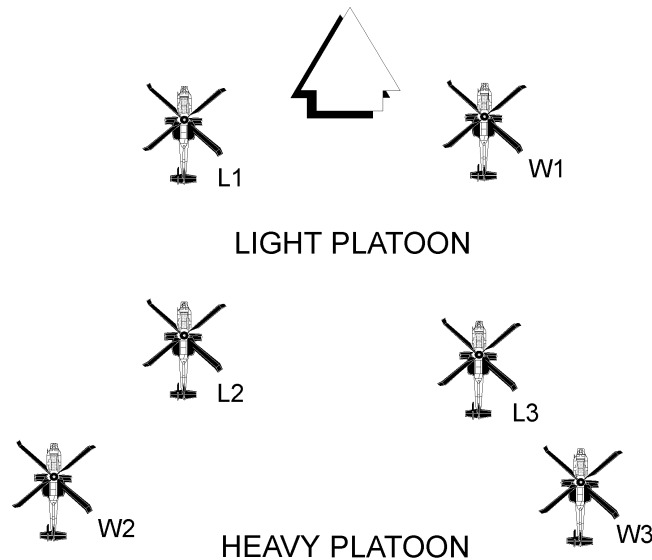

Figure 3-23. Heavy platoon using a wedge formation; light platoon using a combat-spread formation

f. **Passage of Lines.** A passage of lines is an operation in which one unit is passed through the position of another. The ATKHB does not pass through a unit in the same sense as a ground maneuver unit. The ATKHB will, however, pass through the airspace of other units' positions, which can be equally as dangerous. Up to the coordinating altitude, this airspace is controlled by the ground commander. When it is unable to bypass a ground unit, the ATKHB must coordinate its movements over the ground unit through the use of the various echelons of A²C². However, when the ATKHB crosses forward of friendly lines, it should establish liaison with those units that will be passed, especially during a rearward passage of lines.

(1) A passage of lines is necessary when one unit cannot bypass another. The ATKHB may conduct a passage of lines to--

- (a) Counterattack.
- (b) Conduct a raid.
- (c) Envelop an enemy force.

- (d) Pursue a fleeing enemy.
- (e) Exploit an attack by ground forces.
- (f) Withdraw from a covering force mission.

(2) The ATKHB commander must ensure that liaison is established with the stationary force. Early liaison ensures coordination and security for the execution of the passage of lines. The liaison officer is responsible for ensuring that ground commanders (down to company level) know the time and place of the passage of lines and the route that the ATKHB will be using. The liaison officer should be at the passage point when the ATKHB conducts its passage of lines. Because of the nature of attack helicopter operations, this will mean that the liaison officer may be at the ground unit's location for several hours.

(3) Direct and indirect fires of the stationary unit can be integrated into the SEAD plan of the passing ATKHB. Liaison will ensure coordinated and responsive support.

(4) A thorough reconnaissance should be executed prior to the passage of lines. The reconnaissance should note existing and proposed troop locations. A technique to help ensure deception during a passage of lines is to limit the number and size of reconnaissance parties and use the vehicles of the stationary unit.

(5) During the planning process, commanders and staffs of the units involved must coordinate--

- (a) Exchange of intelligence.
- (b) Exchange of SOI information.
- (c) Exchange of liaison personnel.
- (d) Arrangements for reconnaissance.
- (e) Tactical cover and deception plans.
- (f) Security measures during the passage.
- (g) Fires and other CS to be provided by the unit in contact.
- (h) AD weapons status during the passage, which should be weapons

hold.

(6) For a passage of lines, the commander will normally try to pass all of his helicopters through the passage point as quickly as possible. Based on the threat and the terrain, the commander should use a staggered formation, while exercising the option of

FM 1-112

reducing the gaps between the teams to less than 10 rotor diameters (rotor tip to rotor tip). This formation will allow the teams to maintain orientation, while leaving maneuver space.

g. Actions on Contact.

(1) Appendix F describes detailed TTP for performing actions on contact. This appendix establishes the battle drill doctrine of "avoid, evade, threaten, and engage," and applies it to air and ground threats.

(2) Air movement during an attack may result in a meeting engagement. Such engagements occur when contact with the enemy is made suddenly, with little or no prior information concerning its size, location, and disposition. For example, on a raid, the mission may become unhinged by one encounter with a threat. The intent is to avoid the threat, report its position, maneuver to destroy it, if possible, and continue the mission.

(3) During movement, a stationary or moving enemy force may be encountered. When contact is made, the reactions of leaders in the first few seconds or minutes may determine the fight. Generally, the platoon under fire moves aggressively using fire and maneuver to suppress the enemy, seeks covered and concealed fighting positions, and establishes a base of fire. These actions will be accomplished through battle drills executed by the platoon and team. The platoon leader will send a contact report, and the company commander will determine whether to develop the situation or bypass and continue the mission.

(4) The element in contact continues the fight and gains information. The density and type of enemy fire and other terrain information helps to assess enemy capabilities. The platoon in contact reports all information to the commander. If the platoon in contact is unable to maneuver, the commander may use another platoon(s) and/or indirect fire to put pressure on the enemy in an effort to develop the situation.

(5) Based on the estimate of the situation, the commander should choose one of the following courses of action:

- (a)** Continue to develop the situation.
- (b)** Conduct a hasty attack.
- (c)** Fix the enemy while the remainder of the unit bypasses or conducts a hasty attack.
- (d)** Bypass.

3-8. OCCUPATION OF THE BP/SBF POSITION AND ABF POSITION

Occupation of the BP and SBF are very similar. Occupation of the ABF, while deliberate, is normally characterized by greater freedom of movement than the occupation of the BP/SBF. The paragraphs below will describe, while making distinctions between the actions during occupation of these positions. Except where noted otherwise, the paragraphs below discuss an ATKHC task organization of heavy/attack and light/scout platoons, as discussed earlier in this chapter.

a. ABF Position/SBF Position/BP Identification. To keep confusion to a minimum in the objective area, each company should have its own numbering or lettering scheme to identify its positions. For example, Charlie Company's BPs are always numbered in the "30s" (such as BP 31, 32, and 33) while Bravo Company's BPs are always numbered in the "20s." This will also help prevent confusion when copying graphics.

b. Battle Handover.

(1) Procedures for battle handover are similar for BP/SBF and ABF positions. The major difference is in the time available for coordination. Generally, occupation of the ABF is more time constrained than a BP/SBF.

(2) If a battle handover is being accepted from another company or troop, the ATKHC commander and scouts may move to a HA to meet face-to-face with the ATKHC or reconnaissance troop whom they are relieving. This technique may not always be practical, particularly during raids. Once the situation has been briefed, the ATKHC scouts relieve the on-station scouts and begin continuous observation. The ATKHC commander briefs the heavy and light platoons then orders them to move forward to the selected position using appropriate movement techniques, understanding the scouts have already cleared the route. If the movement requires bounding overwatch, the light platoon leads and the heavy platoon overwatches. At the BP, each platoon takes up its assigned position and receives a target handover from the scouts.

(3) When time is critical, such as when the enemy is already in the EA when scouts arrive in the selected position, the commander may elect to order holding platoons forward as the scouts clear the position. These platoons move as quickly as tactically possible along the attack route and meet their scouts behind the BPs. The scouts direct the platoons to their positions and give them a target handover.

c. Preparation.

(1) **BP/SBF position.** The occupation of a BP or SBF begins when the scouts reconnoiter the attack route from the HA to the position. Once in the position, the scouts deploy to clear the position, confirm map or previous physical reconnaissance information, and determine if the EA is occupied. Further ATKHC action depends upon the enemy situation.

FM 1-112

(a) If the enemy has not yet arrived in the EA, the scouts will continue to observe. The scout sends the ATKHC commander a spot report on the enemy situation and the suitability of platoon BPs. Before the enemy arrives in the EA, a scout sends the ATKHC commander a spot report. The commander then orders his elements to move forward to the position using appropriate movement techniques, understanding the scout has already cleared the route.

(b) When occupying an SBF in conjunction with a ground attack, the ATKHC commander must maintain constant communications with the ground commander. This communication will allow the ATKHC to synchronize his occupation of the SBF with the approach or assault of the ground maneuver unit.

(2) **ABF position.** Because the ABF is a force-oriented control measure, the ATKHC will normally establish multiple ABFs in a sector during mission planning. If conducting a movement to contact, the ATKHC will likely move his company by teams using bounding overwatch. Unlike BP and SBF occupation, the process of clearing the route and position will occur during the course of the movement of the entire ATKHC, not just the scouts.

d. **Occupation.**

(1) **BP/SBF position.** Once the commander issues the order to move to the BP/SBF, the light platoon leads as the heavy platoon overwatches during movement along the attack route. The light platoon will normally occupy the most forward position affording the best view of the target area while exposing the fewest number of helicopters. At the BP/SBF, each platoon takes up its assigned position and receives a target handover from the scouts. If all indications are that the enemy is in the EA and cannot be seen, the ATKHC may have to move forward to get the enemy within sensor range. Sensor range, not weapon range, is the key planning factor when selecting a BP/SBF.

(2) **ABF position.**

(a) When enemy contact has been gained, the commander issues the order for the company to move into the ABF. Based on the positions of the platoons in relation to the enemy and the selected ABF, the platoon nearest the ABF generally occupies first and secures the position to accept the other platoon. The scouts lead into the ABF, keeping the enemy under observation while clearing the route into the ABF.

(b) The commander may elect to set both platoons in one ABF or use separate ABFs for each platoon. Based on METT-T, the commander may choose one ABF for the entire company or separate platoon ABFs. Whichever method is used, once both platoons are set in the ABF, the commander can begin engagement of the enemy. If the enemy is out of sensor range, the commander may decide to move forward for the engagement.

e. **Aircraft Positioning.**

(1) **Standard set.** All aircraft key off the lead aircraft and begin occupying firing positions to the right of the lead aircraft, in chalk order. This formation may be used unless the commander declares a nonstandard set. Figure 3-24 shows an example of a standard set.

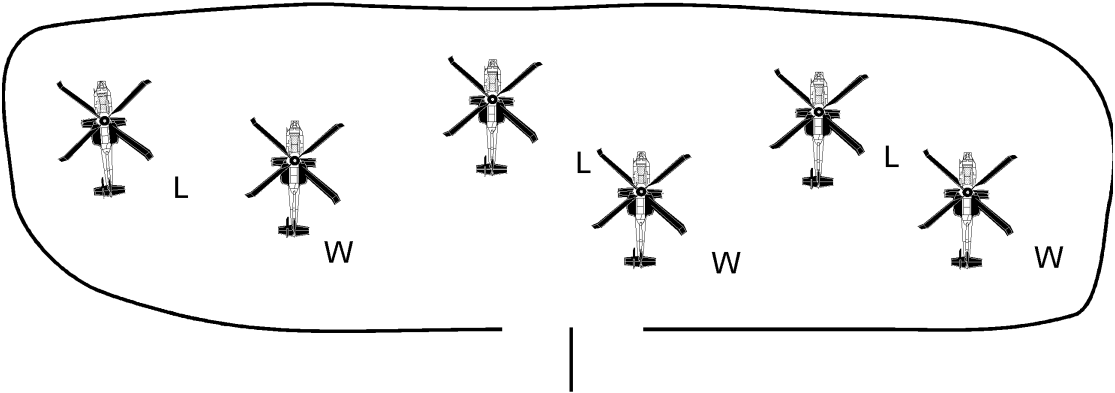

Figure 3-24. Standard set

(2) **Nonstandard set.** All aircraft key off the lead aircraft and begin occupying firing positions to the left of the lead aircraft, in chalk order. Figure 3-25 shows an example of a nonstandard set.

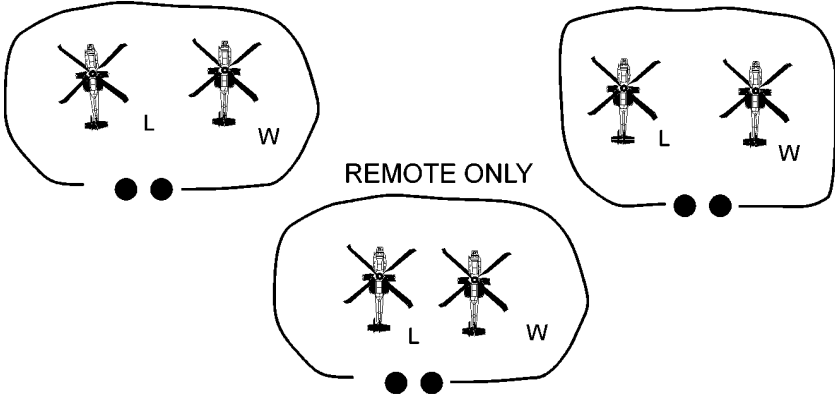

Figure 3-25. Nonstandard set

f. Security.

(1) Both scouts and attack aircraft provide security for the position, whether an ABF, SBF, or BP. After the target handover to the attack aircraft, the scouts move to a position to observe avenues of approach into the position. If a scout makes contact with the enemy, he may engage with his organic weapons or FS, or the ATKHC commander may maneuver one of the platoons into a supplemental BP to meet the threat. The commander may position one of his platoons or teams in an overwatch position to engage enemy air or ground threats.

(2) The commander may choose to position his team to the rear of the other two teams to facilitate C², as well as security. In addition, the commander's aircraft may launch remote missiles for the lead teams without interfering with the commander's C² of the battle.

Section V. Objective Area Overview

The following paragraphs contain detail on EA and direct fire planning. Based on the nature of the mission, commanders must ensure that staffs and aircrews understand these procedures. Effective EA planning and direct fire employment are the essence of attack helicopter operations.

3-9. EA PLANNING

a. Detailed planning is the cornerstone of successful attack helicopter operations. As part of the deliberate decision-making process, this section will concentrate on planning and executing actions on the objective. This planning includes building EAs and executing direct fire in those EAs.

b. The goal of attack helicopter operations is to destroy targets. To destroy targets effectively, without overkill, takes the focusing and massing of fires. Crews must be able to engage targets throughout the depth and length of the EA, killing those targets quickly and efficiently without wasting a single round on a target already destroyed.

c. Attack helicopter units participate in many diverse missions. This diversity can present challenges to unit planners developing EAs and planning direct fire employment. With this in mind, planners must be aware of the differences between attack and reconnaissance and security (reconnaissance) missions. These differences are as follows:

(1) Attack missions normally include massing effects of the unit in a single specified EA. Reconnaissance missions include numerous EAs spread over a wide geographic area using teams of aircraft, rather than the entire unit to engage the enemy.

(2) Attack missions mass precision guided munitions on a readily identifiable enemy. Reconnaissance missions may employ nonprecision munitions such as rockets and artillery to develop the situation and to find the enemy's disposition.

(3) Prior to launching an attack mission, crews normally have a well-developed picture of the enemy situation, and they have high confidence that the enemy force will be in the EA. Reconnaissance missions, like a "search and attack", may not have a well developed enemy situation before commitment of aviation forces.

(4) Weapons loads on attack missions will normally favor precision-guided missiles. Reconnaissance missions, particularly during movement to contact and search and attack will normally include heavier reliance on rockets and cannon.

(5) C² headquarters for attack missions are normally the attack battalion and aviation brigade. Security missions are normally controlled by a ground maneuver TF headquarters.

d. While there are differences in attack and reconnaissance missions, attack mission planning factors vary between close and deep operations. These differences include the following:

(1) Graphics for close operations will normally include restrictive control measures to prevent fratricide during engagements in close proximity to friendly elements.

(2) Actions on the objective: what if the enemy is not in the EA? In a close fight, the attack unit would maneuver to establish contact with the enemy force. In deep operations, units normally lead with one company, whose mission is to develop the situation. Upon making contact with the enemy force, the remaining companies close to mass fires in the EA.

(3) Weapons loads for AH-64s may vary as auxiliary fuel tanks may be added for long-duration deep attacks. In addition, commanders may choose to include auxiliary fuel tanks on aircraft in close fights to increase station time in the objective area.

(4) C² headquarters for close fights are normally the ground element in contact. Deep attacks are normally controlled at the aviation brigade level, with additional guidance from the division or corps DOCC.

3-10. PRINCIPLES OF DIRECT FIRE

a. **Mass Fires.** Commanders must mass the effects of organic onboard weapons in the EA. Additionally, they should use complimentary systems, such as artillery, CAS, mortars, and other available systems to overwhelm the enemy at the decisive place and time.

FM 1-112

b. Leaders Control Fires. Piecemeal fires limit the capability of the attack helicopter unit. There must always be two methods of executing the fires. One method can be voice, but there has to be a backup.

c. Focus Fires. Fires must be focused on the critical point, at the critical time as identified by the IPB. The three key elements to successful massing of direct fires against any target are--

- (1) Clearly conveying instructions to fire elements.
- (2) Using recognizable control measures, whether friendly, enemy, or terrain-based.
- (3) Detailed training, SOPs, and planning for the engagement.

d. Distribute Fires. Figure 3-26 shows the methods for distributing direct fires in the EA. Principles for distributing fires are as follows:

- (1) Critical targets are engaged first.
- (2) Engagements are conducted laterally and in depth simultaneously.
- (3) Which weapons will engage which targets is decided beforehand.
- (4) The order in which to engage targets has been decided.

e. Shift Fires. Fires must be controlled and shifted to react to the enemy's actions. The shifting should be planned and rehearsed.

f. Fire Plan. All crew must understand the fire plan. This includes understanding the mission and the commander's intent.

g. Rehearse the Fire Plan. The fire plan rehearsal will allow every crew to understand it and point out any shortcoming in the plan before execution.

3-11. PRINCIPLES OF FIRE CONTROL

a. Avoid Target Overkill. More than any other factor, this will increase a weapon's P_k . In a target-rich environment, a unit may expend its ammunition and still not meet the defeat criteria stated in the commander's intent. For example, fire discipline will prevent crews from firing 10 ATGMs simultaneously at only two vehicles.

1. CLOSEST TRP

Commanders may establish TRPs using man-made structures, terrain features, enemy formations, or artificial illumination. TRPs should be easily recognizable, as well as easy to locate in the EA when directing or shifting fires.

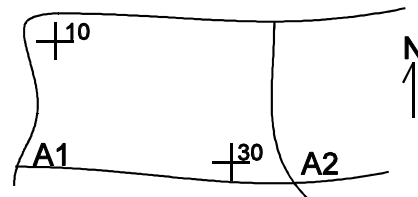

2. QUADRANTS

Commanders may divide the EA into quadrants. Using recognizable terrain features or man-made structures, fires can be directed or shifted quickly by using the assigned quadrant name.

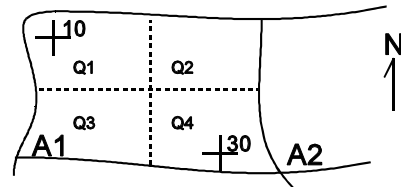

3. FIRE PATTERNS

Fire patterns are an enemy-oriented method of engagement where the focus and distribution of fires are determined by the enemy's formations or location. Fire patterns are frontal and depth, and can be used to direct and shift fires quickly. The commander directs "near, far, left, or right" when directing or shifting fires.

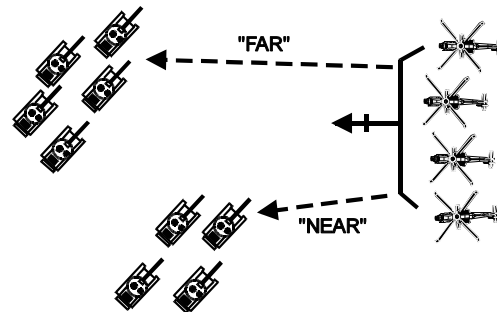

4. TARGET ARRAY

Focusing fires on the enemy target array is a technique where the commander issues specific portions of the formation for engagement. For this technique to be successful, definable portions of the target array must be observed by the commander and the firing crews, particularly during the shifting of fires.

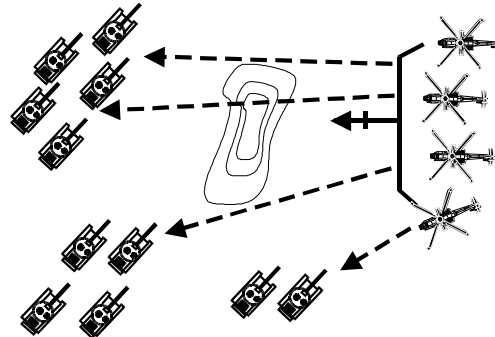

5. SECTORS

Using broad sectors for companies or teams ensures overlapping fires throughout the EA. This technique requires careful direct fire planning to prevent target overkill in the complementary sectors. As with all techniques, the battalion must select the trigger mechanism to initiate the fires -- this is critical with sectors because all fires may not begin simultaneously.

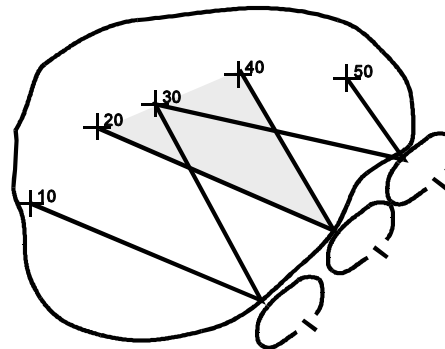

Figure 3-26. Techniques of fire distribution and control

b. Use Each Weapon System in its Best Role. If all ATGMs have been expended against the trucks in a formation, and a tank battalion enters the EA, the attack helicopter unit may not be able to accomplish its mission. A complete IPB will help the commander decide which targets should be serviced by which weapon.

c. Destroy the Most Dangerous Targets First. These targets pose the greatest threat to the force, and must be destroyed to expose the more lucrative targets. Commanders must ensure engagement priorities are understood by all crews.

d. Concentrate on Long-Range Targets. This principle will provide standoff, and allow the commander time and maneuver space should the enemy maneuver toward his position. The commander must understand, however, the limitations of his crews, weapons, and sensors to make the determination at what ranges targets can be engaged while retaining a high P_k . Environmental conditions may reduce the useable range of ATGMs. For example, a Hellfire missile can be used to engage targets at ranges in excess of 8 kilometers. However, environmental conditions may affect the tracking sensor, reducing the useable range to half of the maximum range.

e. Take the Best Shots. The last principle of fire control is to take the best shots and expose only those aircraft. This principle maximizes the P_h and P_k . It also protects the aircraft as long as possible and will lead to confusion among the enemy as to the size and disposition of your force.

Section VI. EA Development

Battalions plan EAs and companies conduct direct fire planning. The following paragraphs, divided into three steps, explain the process of EA development.

3-12. STEP 1: IPB. (See Figure 3-27.)

a. Once the battalion receives its mission, the S2 begins the IPB process. This process consists of several steps--

- (1) Battlefield area evaluation.
- (2) Terrain analysis.
- (3) Weather analysis.
- (4) Enemy evaluation.
- (5) Enemy integration.

b. This process gives the commander possible enemy courses of action. The S2 lists these courses (most probable through most dangerous) in descending probability and

selects areas or points along enemy mobility corridors that confirm or deny a particular enemy COA. These areas or points are called NAI. Enemy activity, or lack of activity, in an NAI assists the S2 in further refining his estimate of the enemy courses of action.

c. The S2, in conjunction with the S3, selects areas or points along these enemy mobility corridors where interdiction of enemy forces by maneuver, fires, or jamming will deprive the enemy of a particular capability. These areas or points are called target areas of interest.

d. Further points are selected, based on time and space, where critical events will occur which will necessitate a decision. These points are called decision points. For example, the commander may designate the enemy's crossing of DP1 as the event that requires his decision whether or not to launch the attack.

e. The IPB process drives the formulation of subunit plans. When the company commander receives the OPORD, he performs the IPB process on his piece of the battlefield. At a minimum, the S2 should have answered the following questions:

- (1) Where is the enemy currently located?
- (2) Where is the enemy going?
- (3) Where can we best engage the enemy?
- (4) When will the enemy be there?
- (5) What weapons systems does the enemy have that can affect the unit?

f. Answering these five questions will yield the enemy's "most probable" COA. After the plan is complete, the S2 shows how the enemy action can unhinge the unit plan. These enemy actions constitute the "most dangerous" COA.

3-13. STEP 2: SELECT THE GROUND FOR THE ATTACK (See Figure 3-27)

a. Once the S2 identifies the enemy's most probable COA, the battalion commander picks the point on the ground where he wants to kill the enemy. This point is where the commander intends to mass his combat power.

b. During this step, the commander issues or reconfirms his nine elements of commander's guidance. These nine elements are listed below.

(1) **Guidance on enemy COA.** This element lets the staff know which actions to focus on and which actions to dismiss.

(2) **The restated mission.** This element is the approved mission by the commander that includes all specified and implied tasks.

(3) **The commander's intent.** This element is the purpose, method, and end state of the mission. It clearly states what is to be done.

(4) **The concept of operation.** This element features the where, when, and how the commander expects to accomplish the mission.

(5) **The deception objective.** This element is the deception (if applicable) tied into the higher commander's plan. This may include "deception SEAD" .

(6) **Priorities.** These elements are the commander's CS and CSS priorities. Focus on the fueling, fixing, and rearming functions for the fight.

(7) **The time plan.** This element focuses the staff on the amount of time available to the battalion for EA planning, as well as the time available to the companies for direct fire planning.

(8) **The type of order to issue.** This element gives the staff guidance on the type of order to issue to the companies so they can complete their plan.

(9) **The type of rehearsal to conduct.** This element is critical prior to execution.

3-14. STEP 3: INTEGRATION OF THE EA (Figures 3-28 through 3-30.)

The EA is an area in which the commander intends to trap and destroy an enemy force with the massed fires of all available weapons. EAs are terrain-oriented control measures that focus the fires, but normally will not help to distribute them throughout the target without additional direct fire planning by the companies. The commander and staff must consider the following when integrating the BOSs in the EA.

a. The staff picks preliminary BPs for the engagement area. These locations are based on the commander's guidance, the terrain, and a sensor range that will produce a 75-percent P_k for the helicopter's primary precision guided weapon. (An AH-64 night missile engagement using FLIR at a range of 8,000 meters does not meet these criteria.) Integration of direct fire must also consider the following:

(1) Enemy avenues of approach.

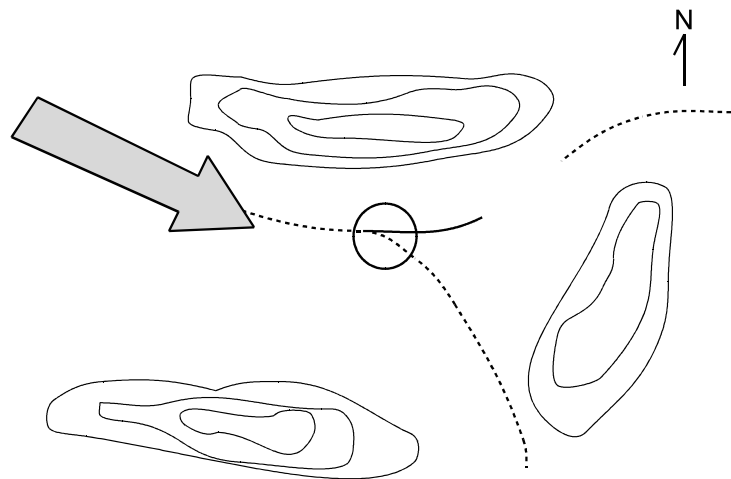

Figure 3-27. Steps 1 and 2

Step 1. The S2 determines where the enemy is currently located, where the enemy is going, where can we best engage the enemy, when the enemy will be there, the weapons systems the enemy has EA that can affect the unit. (Enemy mobility corridor is depicted by arrow, entering objective area from NW).

Step 2. The commander selects the spot on the ground where he wants to mass combat power and kill the enemy. (Circle at road junction indicates commander's designated area.)

- (2) Enemy rate of march.
- (3) Key terrain that will give the advantage for specific avenues of approach.
- (4) What formation(s) the enemy will use, and at what point he is likely to change formation.
- (5) Expected range of engagement.
- (6) When the enemy will begin counter-engagements.
- (7) Effect of enemy indirect fires.
- (8) Where deadspace is in the EA, and how it may be covered.

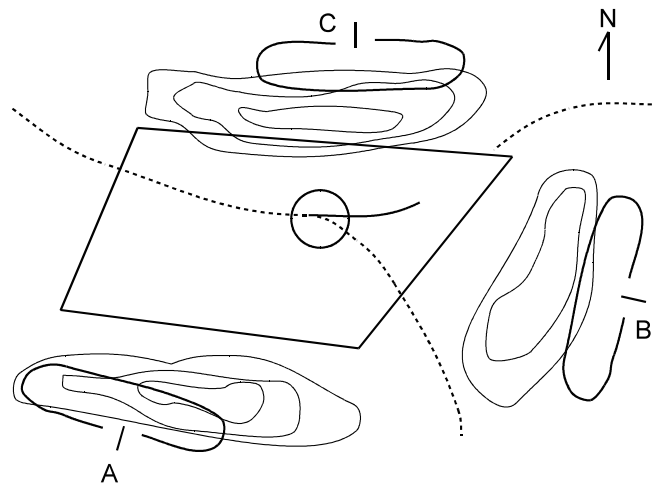

Figure 3-28. Step 3, part 1

Step 3 (Part 1). The S3 decides on the general dimensions of the EA based on the commander's guidance on where he wants to mass the combat power. The S3 picks initial battle positions based on terrain and 75 percent P_k for the helicopter's primary weapon system. In this example, the S3 picks BPs for three companies.

b. During EA integration, the staff will wargame enemy and friendly actions on the objective. The S2 must portray an uncooperative enemy during wargaming to prevent the staff from drawing false conclusions. Specifically,--

- (1) How do we expect the enemy to react upon entering the EA? What tactics will the enemy use?
- (2) What will he do when we start firing at him?
- (3) Where the enemy is likely to dismount and assault?

c. Based on the outcome of the wargame, the FSO, S3, and S2 will integrate the use of artillery, CAS, and mortars to shape the battlespace for the direct fire fight. This integration is based on the commander's intent for fires on the objective. The following questions must be answered:

- (1) What is the end state of the indirect fire plan?

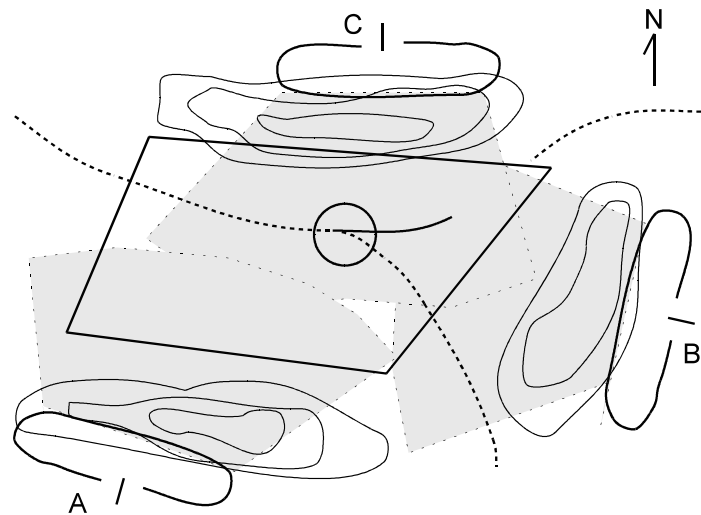

Figure 3-29. Step 3, part 2

Step 3 (Part 2). The S3 further refines the EA, and determines that A Company's BP must be moved to ensure complementary direct fires. In this example, fans are added to the BP to represent direct fire sensor ranges of the helicopters.

- (2) How much artillery/CAS/mortars is available for employment in the EA?
- (3) Who will initiate the fires?
- (4) How will the unit shift fires?
- (5) Who will clear fires once the direct fire fight begins.

d. One area of concern that rarely receives proper planning is the obscured EA. While the EA may be perfectly clear when the first rounds are fired, burning vehicles and munition impacts may quickly obscure the view from the planned battle positions. The staff must consider the following during planning:

(1) Prevailing/forecast winds. The wind direction in the EA is very important. During the planning process, forecast winds in the EA that will obscure either the BP or the EA must be considered for engagement priorities and techniques. Smoke and dust in the EA or BP may cause laser ranging and designation to be unreliable.

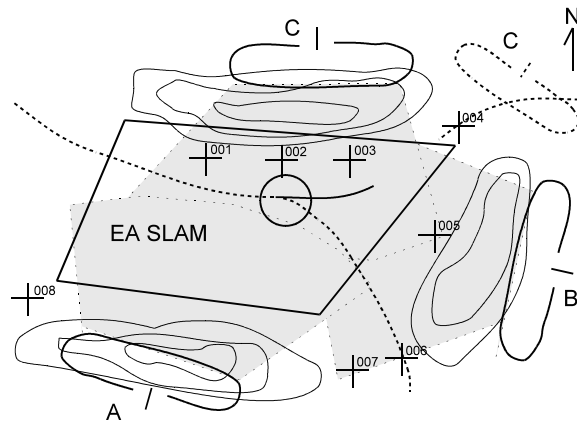

Figure 3-30. Step 3, part 3

Step 3 (Part 3). Based on the wargame, the S3, S2, and FSO further refine the EA, integrating FS into the EA. In this example, TRPs are added to cover possible escape routes in the northeast and southeast, as well as covering dead space near C Company's BP in the north.

(2) Nature of the target. If the targets to be engaged have the propensity to burn after being hit, thought must be given to engagement priorities. For example, a brightly burning light skinned vehicle near the battle position may obscure heavier, more dangerous vehicles in the EA.

(3) Number of targets. If the plan specifies killing a large number of targets with direct fire, consider engaging targets across the depth of the formation simultaneously. This will tend to disorganize the formation quickly, and allow engagements throughout the EA with rockets and indirect fire.

(4) Terrain. Cover deadspace with indirect fire or rockets. Also be aware that smoke tends to cling in the low ground during hours of darkness. This may allow vehicles to move undetected. If they are detected, it is difficult, if not impossible, to engage vehicles in smoke with laser-guided weapons.

(5) Planned obscurants. FLIR sights may be required during daylight operations for target engagement to see through deliberate enemy, and possibly friendly obscurants, such as smoke screens. Aircrews must complete boresights and operational checks of all sights, whether or not the crew expects to use them during the mission.

e. Once the staff planning is complete, the commander should be able to answer yes to each of the questions in EA checklist (Figure 3-31). Once the staff planning identifies the EA and FS plan, the staff should integrate company direct fire planning.

| DOES THE PLAN -- | YES | NO |
|---|-----|----|
| AVOID OVERKILL (CONSERVE AMMUNITION, COMBAT POWER)? | | |
| CONCENTRATE ON LONG RANGE TARGETS? | | |
| ENGAGE TARGETS WITH HIGH P _H ? | | |
| TAKE BEST SHOTS? | | |
| MINIMIZE RISK? | | |
| DESTROY MOST DANGEROUS FIRST? | | |
| MAXIMIZE EACH WEAPON SYSTEM? | | |

Figure 3-31. EA checklist

Section VII. Direct Fire Planning

3-15. STEP 4: PLANNING THE DIRECT FIRE FIGHT (See Figures 3-32 and 3-33.)

The staff identifies the EA and integrates FS on the terrain to engage the templated enemy force. This plan supports the commander's intent for the EA, but more detailed planning is required. The staff passes the EA information to the companies for more detailed planning. This information may be passed for concurrent planning with the battalion staff, or in the form of an OPORD or plan for subsequent planning.

a. The company commander gathers his crews or designated planners initially to get a view of the battalion's plan. Using the overlay and any additional information provided by the staff, he ensures that everyone can identify the TRPs, obstacles, avenues of approach, prominent terrain features, and dead space present in the EA.

b. Using TRPs, terrain features, or man-made obstacles, the company commander sectors the EA by ensuring each crew has a well-defined and understood responsibility. An individual helicopter sector should be wide enough to allow some overlap with adjacent helicopters, but narrow enough to prevent overkill. This reduces the scanning required by the gunner and the potential for overkill; it also ensures the entire EA or sector is covered by direct fire.

c. Based on the commander's guidance, the company commander establishes control measures for the direct-fire fight and other actions that are time or space dependent. Ninety-nine percent of the time the battalion commander establishes a trigger line for the direct fire fight, but the company commander initiates it. Further visualization will help the commander decide whether to have all his crews orient on the TRPs assigned by the battalion, or to have a leader and wingman or individual helicopters orient in slightly different areas. For example, if the platoon leader is told to orient on

FM 1-112

TRP 0006, he might decide on one of the following missions for his subordinates, based on the enemy and terrain:

(1) All crews orient on TRP 0006.

(2) The platoon leader's team orients to the left of TRP 0006, while the other team orients to the right (designating targets 0006A and 0006B).

d. When the company commander decides how to use his helicopters to best meet the battalion commander's intent, he ensures sectors of fire provide full mutual support between helicopters and integrates FS. This planning includes the following:

(1) The commander must plan for rear and flank security in the BP. One to two of the attack helicopters in the company may be designated to provide this security during the engagement.

(2) The direct fire plan will designate responsibilities for long range direct fires. However, the commander must also define the areas designated for engagement with rockets and cannon, and how those fires are initiated. For planning purposes, "fans," or arcs should be drawn on the sector sketch to represent weapons ranges and when they should be employed. This planning factor helps the crews to select the proper weapon for the target at certain ranges.

(3) Crews must also be ready to repel dismounted infantry and other vehicles in the battle position. They must also know the positions of friendly elements in the area.

e. The commander must ensure that supplementary battle positions integrate the same level of planning and FS as the primary positions. Each crew must have a thorough understanding of the criteria for movement from the primary to the supplemental battle positions.

f. Last, the company commander must devise a method to determine if his company accomplished its mission. Because the destruction criteria and end state is in the commander's intent, the commander must be sure the engagement does not conclude until the destruction criteria is met.

3-16. STEP 5: FIRE COMMANDS

a. The commander uses two processes to control fires and always has a primary and alternate method in effect: **fire planning (triggers) and fire commands (radio messages)**. He decides how to control fires based on the situation and the time available to plan and prepare.

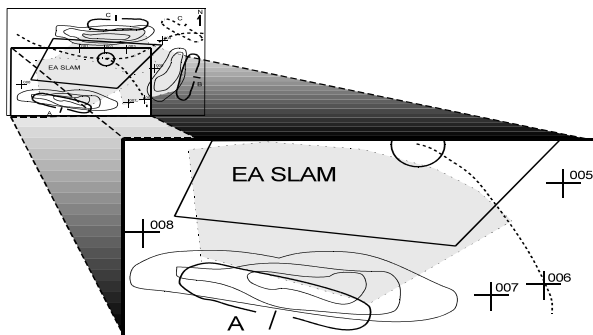

Figure 3-32. Step 4, part 1

Step 4, Part 1. The company commander and his planners examine the EA and start development of their assigned terrain. This example shows A Company's assigned sector of the EA.

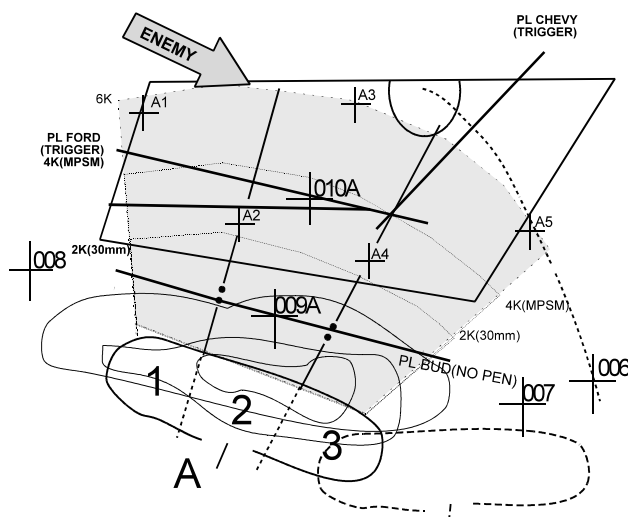

Figure 3-33. Step 4, part 2

Step 4, Part 2. The company commander and his planners further refine the battalion's plan for the EA. In this example, the commander divides the EA into three team-size sectors (Teams 1, 2, and 3). The battalion coordinates PL CHEVY and PL FORD as triggers for A Company to commence the direct fire fight. (The battalion S2 predicts the enemy will move generally eastward through the EA. PLs CHEVY and FORD are designed so A Company has flank shots on the enemy. They also allow synchronization of fires with B and C Companies.) Company TRPs (A1 through A5) are placed to allow for rapid shifting of fires. Two registered artillery TRPs (009A and 010A) are placed in the EA to allow rapid adjustment of indirect fires (Team 2 is responsible for artillery calls). PL BUD, a "no penetration" (NO PEN) line, is placed near the BP. If enemy elements cross PL BUD, crews are instructed to move to the alternate battle position.

(1) In a meeting engagement or in a movement to contact when time to plan is limited, the commander initiates fires with a fire command. During the fight, fires are controlled by fire patterns (See figure 3-34) as specified in the SOP.

| | |
|------------------------------|-------------|
| "BLUE -- THIS IS BLUE SIX -- | Alert |
| THREE TANKS, MULTIPLE BMPs | Description |
| VICINITY TRP ZERO ONE SIX -- | Orientation |
| AT MY COMMAND -- FIRE" | Execution |

Figure 3-34. Unit fire command

(2) In a deliberate attack with prior planning time available, the commander initiates the fight with a fire command or an event (enemy crossing a trigger line). He relies on detailed planning and preparation to distribute fires during the fight. Further fire commands may be required, but the object of the planning phase is to anticipate events and coordinate fires before the fight starts.

(3) A coordinated fire plan requires minimum radio traffic over the net during execution; trigger points, priority of engagements, and targets are established in advance. A trigger point, in concert with a fire command should be used to initiate fires. This assures that direct fires are placed on the enemy even if communications are interrupted or the unit leadership is disabled.

REMEMBER: The use of fire commands is based on knowledge of enemy and time available to plan, prepare, and rehearse.

b. Standardized fire commands are established in the unit SOP and should be practiced by the chain of command. Using a standard format for a fire command ensures that all essential information and control measures are given quickly and accurately. Even under the most adverse conditions, this causes positive reaction by the unit. Brevity and clarity are essential. Abbreviated methods for identifying target locations are encouraged, but they must be familiar and understandable.

c. Coordinating instructions for additional information may be given by the commander to individual aircraft; this information is not part of the fire command. When a crew renders a contact or spot report and it is reasonable to believe all other aircraft in the company received it, the commander issues only the elements needed to complete a

fire command. In all cases, a crew has the freedom to engage a target without a company fire command if he is under immediate threat.

d. A standard unit fire command may include as many as five elements in the following order:

- Alert.
- Weapon or ammunition.
- Target description.
- Orientation.
- Execution.

The paragraphs below describe each element in detail.

(1) Alert. The alert element addresses the crew to fire and does not require the individual initiating the fire command to identify himself. When time is not vital, the individual giving the alert may identify himself. SOP code words may be used as the alert element. The fire command examples in this chapter use the following code words:

- BLUE --Entire company prepare to fire (This assumes the other platoons use "RED" or "WHITE" as identification)
- ALPHA --Platoon leader and his wingman(Team 1) prepare to fire
- BRAVO -- Team 2 prepare to fire

NOTE: When the commander is controlling the fire commands, he may designate his teams separately. For example, Charlie Company is "BLUE" (with Alpha Company "RED" and Bravo Company "WHITE"), and his four teams designated ALPHA through DELTA.

(2) Weapon or ammunition. The PC and CPG select the ammunition based on the fire distribution plan, the enemy targets, and the status of ammunition (How many PD rockets? MPSM?). The PC decides with which weapon to engage and what type and number of rounds to expend.

(3) Target description. The target description briefly describes the target and must contain number, type, and activity ("THREE TANKS MOVING EAST TO WEST, EA SLAM, Sector A"). If the target is stationary, the activity may be omitted.

(4) Orientation. The commander orients the company on the EA and targets using one of the techniques shown in Figure 3-26.

(5) Execution. The execution element indicates when firing will begin. Normally, this is simply the command "FIRE." If surprise and simultaneous fire are desired, or if the company's fire is to be coordinated with other direct or indirect fires, the execution element "AT MY COMMAND" will be given first. This slight delay allows the coordination of all fires to be completed while the individual crews select their targets, issue crew fire commands, and prepare to engage. If, for any reason, a crew is not prepared to fire (equipment malfunction), the PC informs the platoon leader and his L/W immediately. The PC also estimates and reports the time required for the crew to get the helicopter ready to fight.

e. Control.

(1) The nature of the target will dictate the type of fire pattern used. During premission planning, each crew must have a thorough understanding of how the threat will "look" in the EA and what effects the engagement is expected to have. Whether the company is engaging massed armor formations, or a fixed target such as a radar site, the way each crew executes his fires must be understood. While this is not an element of the fire command, crews will consider their unit fire pattern when engaging.

(2) Crews must be trained on and thoroughly understand the two basic fire patterns--frontal and depth. Each crew member must understand its responsibilities for target engagement by SOP. These two fire patterns cover most situations and promote rapid, effective fire distribution. Regardless of which fire pattern is used, the goal is to engage far and flank targets first, then shift fires to near and center targets. Crews should engage targets, *most dangerous to least dangerous*, in their sector. The commander may make exceptions to engage *most dangerous to least dangerous* targets or to engage a designated priority target (C² vehicles).

(a) The frontal pattern is used when all engaging helicopters have unobstructed fields of fire to their front. Flank helicopters engage targets to the front (right helicopter shoots right target, left helicopter shoots left target) and shift fires toward the center as targets are destroyed. The frontal engagement rule is "near to far -- flank to center." Frontal will normally be the initial fire pattern used if neither is specified.

(b) The depth fire pattern is used when targets are exposed in depth. This is position and formation dependent. The whole company may be required to fire on a column formation in depth, or individual helicopters engaging in their sector may have to fire in depth. If the whole company is firing, it may be possible for each helicopter to fire in depth on a portion of the enemy formation. The far left helicopter engages the far target and shifts fire toward the center of the formation as targets are destroyed. The right center helicopter engages the closest (front) target and shifts fire to the rear as targets are destroyed; the far right helicopter engages the center target and shifts fire to the front as targets are destroyed. All helicopters normally fire simultaneously. If the commander wishes to use something other than simultaneous fire, he specifies which crews will fire in the alert element of the fire command.

(c) While these fire patterns will work during most situations, the commander must ask the question: "What effects do I want my fires to have on the enemy?" The goal should be for the enemy to stay in the EA until it is at the level of strength directed in the commander's intent. The commander must consider that if near targets are always engaged with long-range fires, the enemy force may halt movement and leave the EA prior to the mission being completed.

f. Termination of Engagements. The engagement may be terminated in one of two ways--

- (1) The platoon leader or commander announces "CEASE FIRE."
- (2) All targets are destroyed.

3-17. STEP 6: REVIEWING THE PLAN

To determine if planning is complete before execution, the aircrews and staff should be able to answer the following questions:

- a. What are the mission and endstate?
- b. Where is the enemy and how will he enter the AO? What does his IPB say?
- c. Where are his key weapons? What are their capabilities?
- d. Where are we going to kill the enemy?
- e. Where will we engage him from? Are the ranges realistic? Are the positions too restrictive?
- f. Which enemy systems do we want to engage first?
- g. How will we initiate fires?
- h. Which weapon systems will fire first? On what signal?
- i. What is the desired effect of fires from each system?
- j. How will fires be distributed (laterally and in depth)?
- k. Where will each element focus fires?
- l. How will we mass fires? Do we have the required volume? Do we have the time and assets to do the job in the space given?
- m. Where will C² be? Can the commander see the battlefield?

FM 1-112

n. How do we shift fires? How do we refocus fires? Why do we shift? Does everybody know the "key event" to cause shifting?

o. How do we deal with enemy reactions to our fires?

p. Have we planned for flank and rear security in the BP?

q. Does the plan follow the principles of direct fire?

3-18. STEP 7: REHEARSING THE PLAN

a. Once the commander is satisfied that his crews understand the concept of operation, specifically fire distribution, they are ready to rehearse the plan. The rehearsal should address actions in the EA, as well as planning for contact drills en route and contingencies.

b. A good rehearsal starts at the assembly area with communication checks, progresses to line-up for take-off, follows the route, and into the battle position or objective area. While individual air route rehearsals can be conducted using the AMPS, the participating aircrews must be included in a collective rehearsal. Critical questions that must be asked during the rehearsal include: Who is responsible for initiating the secure communications check? Artillery calls? Rear security? Collecting and sending company spot reports? Initiating fires for the attack? Sending the time for Have Quick? Talking to the Air Force for JAAT? Coordinating with the ground force commander? What radio calls are required during the conduct of the operation? What is the success criteria, and how do we know if we have met it?

c. Conflicts in these areas may come to light during the rehearsal. However, the most important aspect is ensuring that the crew members know and understand the commander's intent and how it will be executed.

3-19. STEP 8: EXECUTING THE PLAN

a. The plan and rehearsal are complete, the decision to commit has been made, and the unit departs on its assigned routes. Once the unit has occupied the BP/ABF/SBF, crews prepare for their engagement. When the targets are identified, a contact or spot report is sent to the commander. The optimal solution is for the commander to issue a fire command with "AT MY COMMAND" as a control element, based on good communications between elements and situational awareness of the commander. At this time, each crew will --

(1) Observe the target array and select the target(s) to engage based on the preplanned fire pattern.

(2) The PC will issue a fire command to the CPG/CPO using the target description indicated by the platoon fire command.

(3) Allow the CPG/CPO to acquire and range his first target.

b. While the individual crews select targets and determine their ranges, the company commander prepares to engage the targets in the EA with artillery according to the battalion commander's intent for fires. Knowing the time of flight for artillery allows the crews to coordinate fires so the indirect fire arrives at the proper time, not during engagements with the direct fires of the helicopters. If the indirect fire arrives too soon, it will obscure the battle area, make direct fire engagements difficult or impossible.

c. On the command "FIRE", or when the enemy reaches the predetermined trigger point, each helicopter begins to engage. If the command to fire is received before a crew has completed all its preparations, the crew must complete preparations and fire as soon as possible. The PC adjusts fire and switches targets according to the fire command or SOP. For example, target engagement priorities may be --

- Most dangerous targets (ADA).
- Tanks, ATGMs.
- C² assets.
- Dangerous targets.
- Least dangerous targets.

Commanders should assign engagement priorities according to the mission.

c. The time a helicopter can safely remain unmasked will depend on the enemy. If the enemy has ADA and tanks in overwatch, or if the enemy is stationary, a crew should complete no more than two engagements from the same firing position. When the crew is not engaging, the helicopter should remask and provide observations or assistance to other crews (for example, remote missile firing).

d. After direct fire has been initiated, fire commands will be referenced on the fire distribution plan chosen.

e. When the engagements are complete, the company commander consolidates the BDA and the FARM report. Based on these reports, the company commander must make the determination whether to continue the attack or to break station. This decision is critical because he has to decide whether or not the mission was accomplished. The report sent to the battalion commander is based on the company commander's assessment of the situation.

3-20. EA DEVELOPMENT/DIRECT FIRE SUMMARY

a. Battalions plan EAs. Companies conduct direct fire planning.

FM 1-112

- b. Standardized fire commands must be established by unit SOP and practiced by all leaders and air crews.
- c. All air crews must understand the basic fire patterns and each crew's responsibilities for target engagement by SOP. These patterns cover most situations and promote rapid, effective fire distribution.
- d. A well-planned engagement requires minimum radio traffic during execution; trigger points, priority of engagements, and targets are established in advance.
- e. P_h of the helicopters munitions is reduced as the helicopter to target range increases. Leaders must plan engagements within the "useable range" of the sensor, not merely "maximum range."
- f. All crew members must understand the mission and the commander's intent.

Section VIII. Completing the Engagement

3-21. BREAKING CONTACT

a. **Breaking Contact.** Breaking contact with the enemy is as important to the ATKHC as beginning the engagement. The break in contact should be swift, decisive, and leave the enemy in doubt as to whether it is still being engaged. The company may break contact by platoon or simultaneously. This may also occur after or during a battle handover.

(1) **By platoon or team.** Breaking contact by platoon is conducted the same as maneuvering by platoon. Rather than moving to another battle position, the platoon moves to a HA, rally point, or FARP. When the company breaks contact, one platoon continues to engage the enemy while the other begins to egress. After the first platoon has cleared the area, the platoon still in contact uses artillery fires to suppress the enemy, breaks contact, and maneuvers as directed by the company commander. In addition to artillery fires used to cover the break of the platoon, fires from another ATKHC, ground forces, or CAS may cover the break of the platoon in contact.

(2) **Simultaneously.** The ATKHC may break contact with the simultaneous departure of both platoons. On order, artillery fires are used to suppress the enemy and the ATKHC breaks contact and maneuvers to a HA, rally point, or FARP. In addition to artillery fires used to cover the break of the ATKHC, fires from another ATKHC, ground forces, or CAS may cover the break of the company in contact.

b. **Battle Handover.** A battle handover between ATKHCs is accomplished at the direction of the ATKHB and is used during continuous and phased employment of the

battalion. By designating a phase line as the BHL, the ATKHB directs the ATKHC to prepare for a battle handover when issuing the OPORD or FRAGO (see Figure 3-35).

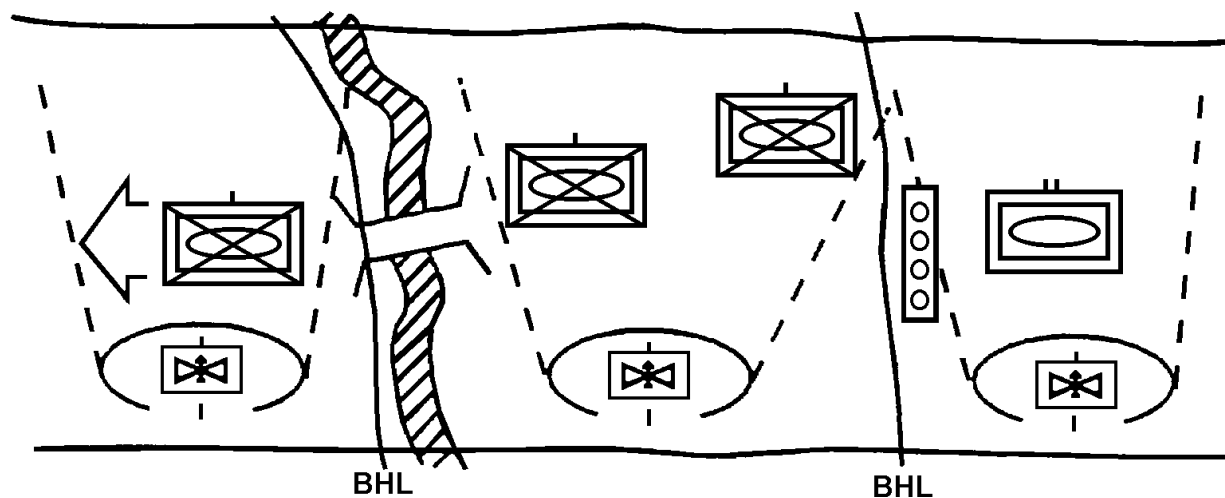

Figure 3-35. Battle handover

(1) **Briefing.** As the time for the battle handover draws near, the scouts of the ATKHC in contact brief the relieving ATKHC on the situation. As a minimum, the briefing should include a description of the enemy force, its location, and direction of movement. If possible, the ATKHC commander in contact briefs the relieving commander face-to-face. If the ATKHC in contact cannot give a face-to-face briefing, then the relieving commander may receive an update briefing by radio or digital message.

(2) **Execution.** The enemy must not be allowed to recover and gain fire superiority through a break in battalion fires. Throughout the battle handover, constant pressure must be exerted on the enemy using direct and indirect fires. After receiving the handover briefing, the relieving ATKHC commander maneuvers his company into the battle positions. When the enemy force reaches the BHL, the ATKHC commander in contact signals the relieving commander by radio, message or another prearranged signal (smoke, rockets, laser, or cannon fire) to begin his engagement. The relieving ATKHC then begins its attack while it covers the withdrawal of the relieved ATKHC. If the company in contact must depart before the relieving company occupies its battle position, the relieved company scouts must maintain contact until the enemy has reached the BHL and a positive handover has been accomplished. The scouts direct artillery fires on the enemy until the handover has been completed.

3-22. EGRESS OPERATIONS

a. **General.** Whether conducting operations during the deep, close, or rear fight, egress begins immediately after "actions at the objective" are completed and the attacking unit has broken contact. Considerations for the egress closely parallel those for ingress, and planning must include the following:

(1) **Route selection.** While the attack unit engages the target, intelligence collection begins to shift to the egress route. Location of enemy radar and AD sites that were illuminated during the ingress and attack phase must be passed to the FSE to update and adjust the SEAD plan. Any new concentration of enemy AD will be reported to the attacking unit.

(2) **Penetration of the FLOT (raids).** When the ATKHB is returning from a cross-FLOT attack, the division or corps must coordinate the passage of lines by changing the AD weapons status of the ground maneuver units. ASE will be employed to defeat all possible threat AD systems during the penetration of the EFLT. Even under the best of circumstances it is difficult to know with accuracy when the aircraft will return across the FLOT, but it is important to plan for egress SEAD. Immediately after crossing the FLOT, companies assemble at designated HAs for sequencing into the FARP. There are two options for point of penetration of the EFLT during deep operations:

(a) Cross the EFLT and FLOT at the same point as the penetration. This can be an effective method if the initial crossing SEAD was effective and ADA systems were destroyed on ingress. Reconsolidation of enemy forces may not have occurred by the time the aircraft return. The enemy unit may still be in some state of disarray, and if the enemy is in contact with friendly ground forces, it will be otherwise occupied. When the friendly aircraft return over the same terrain the enemy will have a difficult time responding to the fast-moving target from their rear.

(b) Cross the EFLT and FLOT at one or several points other than the ingress route. The threat orientation will most likely be toward the friendly forces. The aircraft coming from deep within enemy territory can maintain stealth as they penetrate the EFLT. If each company moves along a separate route then maximum stealth can be maintained. The enemy may not have been alerted or notified of an enemy force penetrating their terrain earlier, or their communications may be jammed or limited to begin with. They will most likely have no idea where the aircraft will recross the EFLT.

b. **BDA.**

(1) Based on the commander's intent and specified attack criteria, the commander controlling the battle must determine whether or not the mission has been accomplished. For example, if the commander specified that 60 percent of the vehicles in a convoy must be destroyed, the commander controlling the battle must be able to decide whether or not the criteria was met before disengaging. A plan must exist to quantify the BDA.

(2) For close operations, the commander may elect to rotate companies through a FARP to reload and reattack the target. However, for cross-FLOT operations, the commander may have a narrow time window to engage the enemy. Because of this compressed schedule, as well as the lack of rearm capability cross-FLOT, the commander may be unable to quantify a BDA upon egress.

(3) For deep operations cross-FLOT, the LRSU and other division/corps reconnaissance assets begin BDA as soon as the egress begins. Sensors obtain intelligence for the division and corps to estimate the enemy's combat effectiveness. They also provide probable courses of action and a window of opportunity for friendly maneuver deep fires.

3-23. RESTORATION

The restoration phase begins when the attacking unit has completed recrossing the FLOT. The restoration phase is broken down into four separate tasks.

a. **Refueling/Rearming.** Refueling will occur at either an active Jump FARP or at the Base FARP. The aircrews may not be familiar with the location of a new FARP, and will be fatigued from the mission. A procedure to guide the returning aircraft into the FARP and then to the AA should be considered.

b. **Occupation of the Assembly Area.** When the aircraft return to the AA each company must have a designated recovery team standing by. Aircraft status and any battle damage is reported to the commander. Each member of the crew must be familiar with recovery procedures, especially for night recovery. Crews should secure gun camera videos and conduct a hasty company AAR in preparation for the battalion AAR. Mission crews may then be expected to participate in at least a battalion level AAR. If all crews are not required at the AAR, commanders and platoon leaders must have consolidated data and information. After crews are debriefed by the S-2, they begin preparation for follow on operations or begin crew rest.

c. **Maintenance.** Initial maintenance and documentation is started immediately after shut down and postflight. Aircraft status is reported to the AVUM. If battalion AVUM maintenance is required, the decision is made to dispatch contact teams or fly the aircraft to the AVUM's location.

d. **Transition to Future Operations.** When the AAR is complete and all aircrews are debriefed, the entire battalion then turns its attention to getting ready for follow on operations. Close operations may be conducted immediately following a raid depending on the assets used during the previous operations. Battalion level preparation should focus on mission analysis of future operations, logistics, and maintenance requirements for future operations, and orders dissemination and rehearsals. Company level preparation for future operations should focus on aircraft maintenance, fighter management, and planning cell development of future operations.

Section IX. Other Operations

3-24. RECONNAISSANCE AND SECURITY

Although primarily associated with cavalry units, reconnaissance and security operations are implied requirements of ATKHBs. Because of where and how they operate on the battlefield and their aircraft capabilities, attack helicopter units may be tasked to conduct reconnaissance and security missions. These missions may be conducted autonomously or as part of a larger force. Because of this possibility, it is imperative that attack crews and units be proficient in the missions and fundamentals associated with reconnaissance and security.

a. Reconnaissance. The primary purpose of reconnaissance is to gain information of tactical importance upon which commanders will make plans and issue orders for the conduct of future combat operations. Combat information is a by-product of all operations acquired continuously as they progress. Attack helicopter crews invariably gather information as they fly and are particularly well suited for aerial reconnaissance. In fact, if it is not stated specifically in mission orders, reconnaissance is always an implied task during all phases of attack helicopter operations.

(1) Reconnaissance operations vary with every situation. Whether conducted alone or with ground elements, attack helicopters task organize according to METT-T. Normally scout-weapons teams are formed. The designated "scout" focuses primarily on the reconnaissance effort and the other team member maintains a protective overwatch position oriented on the scout. The purpose of the "scout" team member is aerial observation (terrain and enemy oriented) and the primary purpose of the "attack" team member is to protect the scout and provide suppressive fires (enemy oriented) and help develop the situation.

(2) Reconnaissance operations are conducted according to the following six principles:

- (a)** Orient on the reconnaissance objective.
- (b)** Maximum reconnaissance power forward.
- (c)** Report all information rapidly and accurately.
- (d)** Retain freedom to maneuver.
- (e)** Gain and maintain enemy contact.
- (f)** Develop the situation rapidly.

(3) There are four forms of reconnaissance the ATKHB can conduct. These forms include route, zone, area, and RIF.

(a) **Route reconnaissance.** A route reconnaissance is a reconnaissance effort along a specific line of communications, such as a road, railway, or waterway. It provides new or updated information on route conditions and activities along a specific route.

(b) **Zone reconnaissance.** A zone reconnaissance is a directed effort to obtain detailed information within a zone defined by boundaries. A zone reconnaissance provides data concerning all routes, obstacles (to include chemical or radiological contamination), terrain, and enemy forces within the zone of action.

(c) **Area reconnaissance.** An area reconnaissance provides detailed information concerning the terrain or enemy activity within a prescribed area, such as a town, ridge line, woods, or other feature critical to operations. Areas are smaller than zones. (A zone reconnaissance may include several area reconnaissances). At its most basic level, an area reconnaissance could be made of a single point, such as a bridge or an installation.

(d) **RIF.** RIF is a limited purpose form of reconnaissance conducted to obtain information and test enemy dispositions, strengths, and reactions. It is conducted to aggressively develop the situation. A RIF is conducted when the enemy is known to be operating in strength within a given area and sufficient intelligence cannot be developed by another means.

(e) A detailed discussion of these missions and their TTP can be found in FMs 100-40, 1-114, and 17-95.

b. Security. Security operations are designed to provide reaction, maneuver space, and protection for the force as a whole. They are characterized by aggressive reconnaissance to reduce unknowns, gain and maintain contact with the enemy and provide early and accurate warning to the main body. The primary orientation of the ATKHB during a security mission is the protection of the main body as opposed to a terrain or enemy objective. An ATKHB may be assigned a security mission to protect the command against surprise attack and observation by hostile air and ground forces. They maintain freedom of maneuver for the command by providing reaction time and maneuver space.

(1) Security forces may operate at varying distance from the main body and to any flank based on conditions of METT-T. They employ the minimum combat power necessary to cover extended frontages and provide the commander early warning.

(2) Security operations include screen, guard, cover, and area security. An aviation specific mission, air assault security, is a form of a guard operation.

(a) **Screen.** A screen is a form of security that primarily provides early warning. It observes, identifies, and reports information. It generally fights only in self-defense, but does engage enemy reconnaissance elements within its capabilities. Commanders generally establish screens on an extended flank, to the rear, or to the front

FM 1-112

of a stationary force. A screen is not conducted forward of a moving force; the security element forward of a moving force must conduct either a guard or cover. A screen is essentially an outpost line, consisting of OPs that may reposition laterally along the outpost line (a designated phase line).

(b) Guard. Guard is a form of security in which a unit is tasked to protect the main body by preventing the enemy from being able to engage main body forces with direct fire weapons. The guard force accomplished its task by reconnoitering, attacking, defending, and delaying enemy forces to provide time for the main body commander to counter enemy actions. A guard force operates within supporting range of the main body. A guard differs from a screen in that it contains greater combat capabilities and is employed to engage enemy forces as opposed to a screen that only provides early warning and destroys enemy reconnaissance. The commander may use a guard to the front of his main forces (advance guard), to the rear (rear guard) especially during retrograde, or to the flank (flank guard) when there is a threat of significant enemy contact. Also, a screening mission may transition to a guard mission upon the approach of a sizable enemy force.

(c) Cover. A covering force may be used during offensive or defensive operations. It operates independently of the main body to deceive, disorganize, and engage the enemy. While a cover normally operates forward of the main body, it may also operate to the rear or flanks. Although a covering force aggressively develops the situation independent of the main body, a fundamental orientation remains on preventing the surprise and untimely engagement of the main body. A cover differs from a screen or guard in that it is a significant combat force that develops the situation at a considerable distance from the main body. The width of the covering force area will normally be the same size as the zone or sector of the main body, while its depth is METT-T dependent.

(d) Area security. Area security is conducted when the ATKHB is given the mission to secure a specific area. Area security actions could include reconnaissance, rear OPSEC, and security of designated personnel, equipment, facilities, and critical points. Convoy and route security are applications of the area security mission.

(3) Fundamentals of security include--

- Providing early warning and reaction time.
- Orienting on the force or facility to secure.
- Performing continuous reconnaissance.
- Maintaining enemy contact.

d. For a detailed discussion of security operations refer to FMs 1-114 and 17-95. Air assault security is covered in Appendix B.

3-25. JAAT

Army CS elements are not the only resources available to the ATKHB commander for target attack. Joint and combined arms assets such as TACAIR and FA can join the ATKHB to form a JAAT. A JAAT operation is a synchronized, simultaneous attack by attack helicopters, CAS, and FA against an enemy force. The attack may be against a single enemy element or against several enemy elements within a specified area. An ATKHB is frequently called upon to perform a JAAT while conducting its assigned missions. For an ATKHB, a JAAT is a normal mission with the additional CS of CAS. The addition of CAS gives both the ATKHB and CAS team greater survivability while it increases their firepower and complicates the enemy's countering attack. The JAAT may operate either as an integrated member of the combined arms team that reinforces ground maneuver units or as an independent force. In either case, the JAAT is used to support the commander's ground maneuver plan throughout the battlefield.

a. Composition.

(1) **The commander.** The commander (normally brigade or higher) is responsible for the ground and airspace below the coordinating altitude where JAAT operations take place. The commander must synchronize the JAAT into the battle and bring its combined fires into play at the decisive moment. The commander uses the JAAT to attack targets that he would use the ATKHB against. The JAAT, however, has greater combat power; therefore, it can overwhelm an enemy force or attack a larger enemy force. To plan and coordinate the JAAT, the force commander uses his S3, TACP, FSO, and the ATKHB commander or his liaison officer.

(2) **Attack helicopters.** The attack helicopter portion of the JAAT consists of ATKHB aircraft. Except for the additional planning and coordination necessary for a joint operation, the ATKHB will conduct the JAAT operation as they would a normal mission. During the JAAT operation, the ATKHB will plan the operation, coordinate the attacks in the EA, and provide SEAD for attacking CAS aircraft and attack helicopters. Although the ATKHB will provide suppressive fires against enemy AD, the primary armor killers are ATKHB aircraft. The size of the JAAT depends upon the ATKHB commander's analysis of the factors of METT-T and the number of CAS sorties allocated. The JAAT may be composed of one ATKHC with two sorties of CAS, the entire ATKHB with only one ATKHC attacking with CAS, or any number of other combinations.

(3) **TACAIR.** TACAIR consists of tactical aircraft capable of performing CAS. Primarily, these aircraft are the U.S. Air Force A-7, A-10, and F-16; U.S. Navy A-7, and FA-18; and U.S. Marine Corps AV-8 and FA-18, although other tactical aircraft may be employed. JAATs will normally be formed with US Air Force participants. However, US Navy and US Marine Corps assets may be available in some cases. The use of TACAIR significantly increases the combat power of the ATKHB or ATKHC by virtue of the large and varied ordnance payloads available.

(a) The Air Force A-10 provides the most flexible support to JAATs and has several advantages over other tactical aircraft. A-10s were specifically designed and

FM 1-112

dedicated to the CAS mission, their pilots have trained extensively with Army units in JAAT employment, and their communications are compatible. The A-10 has extensive loiter and multipass capabilities and can react quickly to a changing attack plan.

(b) Fielding of advanced aircraft, such as the AH-64D and OH-58D(I), along with other factors such as current and projected improvements in enemy ADs, has caused the Air Force and Army to consider the employment of faster, more survivable TACAIR assets in JAAT missions. TACAIR assets will not normally possess either the extended loiter capability or the capability to visually acquire targets unaided as well as A-10 pilots and aircraft. However, advanced avionics and munitions enable F-16 (LANTIRN) pilots to work effectively with advanced helicopter crews to destroy enemy armor formations safely and effectively. The use of aircraft other than A-10s may require more coordination between the FAC and the ATKHC commander.

(4) **FAC.** The FAC may be an ALO assigned to the supported echelon TACP or an airborne FAC operating in a fixed-wing aircraft outside of the enemy AD envelop to coordinate and control TACAIR in the JAAT. In the absence of a FAC for the operation, the ATKHC commander may coordinate directly with TACAIR. The TACAIR flight leader will control employment of the fighter aircraft.

(5) JAAT FS.

(a) Indirect FS is an important part of the JAAT. FS is normally used to begin the attack, suppress or destroy enemy AD, force armored vehicles to deploy, and create confusion within the C² of the element under fire. The JAAT will obtain FA support from the FA battalion in DS of the ground maneuver brigade. It will also obtain FA support from the GS FA unit supporting the forces as a whole when the JAAT is operating for the division or corps.

(b) If the ATKHB does not have an FSO, FS planning will come from the echelon that plans and coordinates the JAAT. Normally, the DS FA battalion will provide an FSO. The FSO must work closely with the Air Force TACP located at a ground maneuver brigade, division, or corps headquarters so that FS will fit smoothly into the plan. Once the JAAT mission begins, the ATKHC commander or scout works directly with the FSO to coordinate continuous FS. When the ATKHC commander cannot contact the FSO directly, he can--

- Request an OH-58D (I) team from the cavalry squadron or light attack battalion be attached to the JAAT TF to act as the FSO.
- Call or communicate digitally directly to a FA unit that is dedicated to the JAAT mission.
- Use a ground company's FIST team chief to control artillery fires and add ground unit mortar fires if the battalion is conducting operations with a ground force.

b. Mission Planning. Because each member of the JAAT retains his own C² system, mission planning must be a coordinated effort. Constant coordination is required between the ground maneuver commander, aviation commander, TACAIR flight leader/ALO, and FSO. As elements of the mission change, all members must be informed so that they can adjust their plans accordingly. Success of the JAAT operation depends on the proper synchronization of assets and how well each member of the JAAT understands the operation. JAAT operations may be either preplanned, immediate, or spontaneous.

(1) Preplanned. A preplanned JAAT operation is used when time is available to request TACAIR in the normal planning cycle (usually 36 hours). The preplanned request is drafted by the FSO in coordination with the TACP and processed through Army channels to the TACC at the tactical Air Force headquarters. The TACC then processes the request according to priorities selected by the joint force commander.

(2) Immediate. An immediate request for TACAIR is used when time is not available to process the request within the normal planning cycle. The request is transmitted by the appropriate echelon TACP over the Air Force air request net directly to the ASO collocated at the corps TOC. Intermediate level-TACPs monitor these requests and advise their respective commanders. Intermediate echelon commanders may direct their assigned TACP to disapprove the request using the air request net if other assets are available or they otherwise do not support the request. Silence by intermediate-level TACPs for a specified amount of time (normally 15 minutes) is considered approval. Following approval by the corps FSE, the ASOC coordinates with the TACC to fulfill the requirement for TACAIR.

(3) Spontaneous. A spontaneous JAAT operation occurs when all members of the team are available but no time is available to plan and coordinate. To be successful, spontaneous JAAT operations depend on unit SOPs, training, and communications. A successful JAAT operation is possible anytime pilots are able to coordinate actions by talking with each other. A common JAAT frequency that can be used by the team members is a critical portion of a spontaneous JAAT operation and should be included in CEOIs and Air Force ATOs. A common JAAT frequency will allow the ATKHC to communicate and coordinate its attacks with the CAS in a minimal amount of time.

c. Employment. Employment of the JAAT depends on the factors of METT-T. The method of employment is decided as early as possible so that attacking assets can be coordinated. The two basic employment methods are sector attacks, which allow each element of the JAAT to attack within a specified sector, and combined attacks, which occur when JAAT elements mass their fires by attacking in the same sector.

(1) Sector attacks. The three types of sector attacks are sector-simultaneous, sector-sequential, and sector-random.

(a) **Sector-simultaneous.** During sector-simultaneous attacks, each element maneuvers to attack within its assigned sector to engage targets simultaneously with other JAAT elements. All aircraft must coordinate ordnance fans to avoid fratricide.

(b) **Sector-sequential.** During sector-sequential attacks, each element maneuvers to attack within its assigned sector to attack in a predetermined sequence. This sequence may range from several seconds to several minutes. This option reduces the ordnance fan coordination problem and facilitates covering fire for each preceding element.

(c) **Sector-random.** During sector-random attacks, each element maneuvers to attack within its assigned sector and engages targets at will. All elements must coordinate ordnance fans and ensure fratricide avoidance.

(2) **Combined attacks.** The three types of combined attacks are combined-simultaneous, combined-sequential, and combined-random.

(a) **Combined-simultaneous.** During combined-simultaneous attacks, all elements engage targets in the same sector and attack simultaneously. All elements must coordinate ordnance fans and ensure fratricide avoidance.

(b) **Combined-sequential.** During combined-sequential attacks, all elements engage targets in the same sector and attack in a predetermined sequence. This sequence may range from several seconds to several minutes. This option reduces the ordnance fan coordination problem and facilitates covering fire for each preceding element.

(c) **Combined-random.** During combined-random attacks, all elements engage targets in the same sector and attack at will. Once again, all elements must coordinate ordnance fans and ensure fratricide avoidance because attacks may inadvertently be simultaneous.

d. **Conduct of Operations.** After receiving the mission, the ATKHB will conduct mission analysis in as much detail as time allows. All planning, coordinating, analyzing, and rehearsing are conducted to ensure success.

(1) Upon departing the HA, scouts move forward to reconnoiter the target area. Scouts verify battle positions, avenues of approach, obstacles, and potential EAs that have not been already identified. If the enemy has already entered the EAs, scouts maintain contact and attempt to locate its AD systems.

(2) Scouts should establish contact with the unit providing indirect FS during reconnaissance. This contact should continue throughout the mission, with the scouts serving as the FSE on the battlefield during the JAAT. Careful consideration should be given to using artillery prior to direct fire engagements with attack helicopter and CAS. Obscurants generated by the impacting rounds may interfere with laser range finders and designators, degrading the effectiveness of precision guided munitions.

(3) The arrival of the attack helicopters should coincide with the arrival of the CAS at the IP. This is the most difficult part of a JAAT operation. The aviation commander must attempt to flow all the assets into the battle in various combinations without piecemealing the force. As the ATKHC arrives in the battle position, the platoons take up their positions and begin their attack according to the commander's scheme of maneuver. A portion of the ATKHC will most likely begin the attack by engaging AD targets identified by the scouts during their reconnaissance. The platoon (or the number of aircraft) that is assigned to SEAD and security is determined by the local threat. The remainder of the company attacks in sector according to company attack priorities.

(4) When the CAS flight leader arrives in the battle area, he contacts the ALO. He gives the ALO his call sign, mission number, available ordnance, and loiter time. The ALO or the ATKHC commander, if the ALO is not available, passes the target information to the CAS flight leader. The ATKHC commander, the ALO, and the CAS flight leader must have good communications. If the ALO is not in direct contact with the ATKHC commander and cannot communicate quickly with both the ATKHC commander and the CAS flight leader, he should hand over the CAS flight to the ATKHC commander and allow him to control the CAS.

(5) CAS aircraft usually enter the target area in a flight of two. The flight leaves the IP using low-altitude tactical navigation, which maximizes terrain-masking. The flight leader contacts the ALO or the ATKHC commander for an update on friendly and enemy activities. In addition to receiving an update on the situation, the CAS leader should also give an inbound call. This call is expressed in units of time; for example, 30 seconds. The ATKHC commander uses this call to shift fires and coordinate the battle.

(6) As CAS aircraft attack, the ATKHC commander observes their attack. Then directly or through the ALO, the ATKHC commander adjusts the CAS attack by using cardinal headings and distances from the last point of attack. If the ATKHC and CAS aircraft are equipped with lasers and laser-detection devices, the attack helicopters can mark targets, the center mass of the target array, and boundaries of the sector or designate targets for Air Force-delivered, laser-guided precision munitions. The use of lasers increases the speed and security of the attack and reduces the amount of communications necessary between the ATKHC and the CAS flight.

e. **Communications.** The communications link between members of the JAAT is critical. The ATKHC and the TACP must coordinate the frequencies to be used before CAS aircraft arrive at the IP.

f. **Advanced Aircraft Equipped JAAT.**

(1) **Communications.** Communications are the key to effective JAAT operations. The Have Quick radio system on the AH-64, OH-58D (I), AH-1F, and Air Force CAS aircraft allow jam-resistant, nonsecure frequency hopping communications with ALO and CAS elements.

(2) **Laser designation.** The AH-64 and OH-58D(I) laser designator can mark sectors, targets, and enemy positions for CAS aircraft equipped with proper sensing devices. The FAC is responsible for coordinating the laser code used.

(3) **LGB.** The LGB offers improved effects on the targeted enemy force. Laser-guided munitions can destroy bridges and other attack priority targets while allowing CAS aircraft greater survivability.

g. **Briefing.** When briefing the JAAT in the absence of the FAC, the AMC will provide the 9-line brief shown in Figure 3-35 to the CAS aircraft. If the FAC is available to brief the CAS aircraft, the attack brief shown in Figure 3-36 will be used by the AMC.

- | |
|---|
| <ol style="list-style-type: none">1. INITIAL POINT.2. HEADING (MAG).3. DISTANCE (NM).4. TARGET ELEVATION (FT).5. TARGET DESCRIPTION.6. TARGET COORDINATES.7. TARGET MARKS (laser code if applicable).8. FRIENDLY LOCATION.9. EGRESS DIRECTION (MAG). <p>REMARKS AS NECESSARY</p> <ol style="list-style-type: none">A. HAZARDS.B. ATTACK RESTRICTIONS.C. THREATS.D. ABORT CODE.E. CLEARANCE. |
|---|

Figure 3-35. Nine-line brief to eh CAS aircraft

- | |
|---|
| <ol style="list-style-type: none">1. DISTANCE/DIRECTION REFERENCE.2. SPECIFIC TARGET IDENTIFICATION.3. SPECIFIC THREAT IDENTIFICATION.4. SPECIFIC FRIENDLY IDENTIFICATION.5. SPECIFIC ATTACK RESTRICTIONS.6. FAC POSITION.7. FINAL CLEARANCE. |
|---|

Figure 3-36. Attack brief

CHAPTER 4

COMBAT SUPPORT

The ATKHB commander uses combat support elements as combat multipliers to enhance the combat power of the ATKHB. Combat support for the ATKHB is provided by corps and division assets. The ATKHB may receive combat support from direct support, general support, OPCON, or units attached for specific missions. If the ATKHB is placed under OPCON of a ground maneuver brigade, it may receive combat support from units supporting that brigade. Combat support assets include FA, CAS, intelligence, AD, engineers, and chemical units. Knowing combat support capabilities, employing them appropriately, and synchronizing their operations are essential to applying superior combat power at the decisive time and place. This chapter covers the roles of combat support in assisting the ATKHB accomplish its mission.

4-1. FIRE SUPPORT

a. General. Fire support is critical to the success of the ATKHB in combat. The ATKHB commander should use fire support to shape the battlespace to free his attack companies to mass at the critical place and time. The commander should not think of fire support as an afterthought to the scheme of maneuver. Fire support should be used as a combat multiplier capable of negating the enemy's ability to influence a COA. The commander should look for targeting opportunities for fires to replace or supplement direct fire. Fire support enhances the ATKHB commander's combat power by--

- (1) Suppression, neutralization, or destruction of targets.
- (2) Obscuring the vision of enemy forces.
- (3) Isolating enemy forces and positions.
- (4) Slowing and canalizing enemy movements.
- (5) Killing or disabling the enemy at ranges greater than direct fire weapons.
- (6) Screening with smoke or isolating areas with scatterable mines.
- (7) Reducing the effect of enemy artillery with counterfire.
- (8) Interdiction of following enemy formations.

b. Planning.

(1) One of the ATKHB commander's greatest challenges is to synchronize and concentrate all of his combat power at the critical time and place. There are potentially a multitude of targets to engage in a short time, and a time lag from when the decision is made to use supporting fires until the target is hit. The commander alone will not have the time to integrate all of the weapons available to him to increase his combat power. The FSO assists the commander by developing the fire support plan concurrently with the maneuver plan. During the battle, the FSO and fire support section monitor the execution of fire support to ensure compliance with the commander's intent and to provide continuous support. When using fire support, the commander must consider the factors discussed below.

(a) **Fire support to complement maneuver.** Fires are used to accomplish missions that the ATKHCs cannot or that would otherwise divert forces from the main effort. An example is the use of artillery to engage AD systems overwatching enemy movement.

(b) **Surprise.** Massed surprise fires are most effective. The destruction that can be achieved by supporting fire depends on the preparedness of the enemy.

(c) **Most effective roles.** To best integrate fire support, the ATKHB commander must know the capabilities and limitations of all supporting fires and ensure that fire support is used where and when it will be most effective.

(d) **Effects of fire.** Effects of fire include suppression, neutralization, and destruction. Suppression limits the ability of personnel in the target area to perform their jobs. The effects of suppressive fire last only as long as the fires continue. Neutralization temporarily knocks the target out of action, producing 10 percent or more casualties or materiel damage. Most planned missions are neutralization fires. Destruction renders the target ineffective for a prolonged period of time, producing 30 percent or more casualties or materiel damage. Destruction requires large quantities of ammunition or special munitions such as COPPERHEAD or ICM.

(2) The planning and coordination process begins when the mission is received and continues throughout the operation. The commander, X0, S2, S3, and the supporting FSO interact throughout mission planning and execution to ensure that fire planning is a continuing process. When the mission is received, the FSO receives the following guidance from the higher fire support element:

- Fire support asset allocation and status.
- Higher commander's fire support attack guidance.
- Fires planned by higher headquarters in zone.

(3) The commander must clearly state his intent/concept for fire support. To be useful, the commander's intent/concept for fire support must be both understood and feasible. This requires a mutual effort by both the FSO and battalion commander to articulate and understand what fire support can and is expected to accomplish during an operation. The commander's requirements must be within the capabilities of the resources available. The FSO must know and communicate fire support capabilities, limitations, and risks during the process of developing the commander's intent/concept for fire support. The commander's intent/concept must explain--

- The commander's battle space--his vision of lethality projection. It should answer the question, "What do I want to do to the enemy?", and articulate more than just, "Defeat him". It should not refer to a specific scheme of maneuver or to specific organizations.

- What must be accomplished, when, and why.
- How he intends to shape the battle to his advantage in terms of time and space.
- The critical enemy vulnerability (center of gravity) he believes will lead most directly to mission accomplishment.
- Places and times in the fight that are critical.
- Desired endstate in terms of time, force, enemy, and terrain.
- Which units have priority of fires.
- Preliminary guidance on HVT/HPT.
- His special concerns.

(4) Through the planning process, the commander and staff determine how fire support will be used (what type of targets will be attacked, where, when, why, and with what means). The plan is flexible to accommodate the unexpected in combat.

(a) The depth and detail of fire support planning depends on how much time is available. Many of the fire support actions that occur in response to battle situations are established in SOPs or directed in FRAGOs. Fire support planning is continuous and concurrent at all levels.

(b) The fire support plan outlines the way artillery, CAS, and other fire support systems will be used to complement the scheme of maneuver, and it provides instruction for executing those fires. It is used to rank targets in priority order, match them with available fire support systems, eliminate duplication with the targets of the echelon that the ATKHB is supporting, and allow fires to be executed quickly without

FM 1-112

specific direction from the commander once the battle starts. An ATKHB fire support plan may include the following:

- A general concept of how fires will support the attack (Scheme of fires).
- Availability of fire support assets and their status.
- A target list that includes locations where fires are expected or likely to be used. (Known enemy locations should be carefully targeted, but too many targets complicate the fire plan and delay fires.)
- An observation plan that details who is responsible to observe and fire a target and where the observer must be positioned to see the trigger and the target.
- A priority of fires telling which element will receive fire support in case of conflicting needs.
- A priority of targets telling which type of mission to fire first. (HPT list/attack guidance matrix)
- An allocation of priority targets.
- A fire support execution matrix.
- Clearance of fires procedures.
- Informal airspace coordination areas.
- Requirements, restrictions, and priorities for special munitions (DPICM, smoke, illumination, FASCAM, COPPERHEAD).
- Coordination measures for providing troop safety and synchronizing supporting fires.

(c) The fire support plan must explain who will trigger and control fires, where the observer will position to see the trigger and target, which targets to shoot (number/type of vehicle, formation, etc.), when and where to shoot them, which type of indirect weapon and ammunition to shoot at the target, what target effects are desired, and the purpose of shooting the target.

(d) The battalion fire support plan is disseminated in the OPORD. This plan is refined as requests from the ATKHCs and new information are received. Updated fire plans are sent back to the ATKHCs and disseminated to the DS battalion fire direction center and brigade fire support element.

(5) Fire support is an essential part of the ATKHB combined arms rehearsal. Incorporating fire support in the rehearsal will build confidence and understanding between all of the battlefield operating systems. Rehearsals at all levels are key to understanding the concept of the operation, verifying specific responsibilities, timing, and backup procedures to help synchronize unit operations. Any last minute changes to the plan after the rehearsal may cause a reduction in the effectiveness of the fire support. The key fire support points that should be highlighted during the rehearsal are--

- Validation of the fire support plan with the scheme of maneuver, commander's intent, and attack guidance.
- Positioning and ranges of the supporting artillery and mortar units.
- Obstacle/barrier plan synchronization with the fire support plan.
- Fire and maneuver control measures for protecting and controlling aerial and ground forces do not disrupt the fire support plan and are not violated by the plan.
- Target grids and trigger points are verified.
- Redundant observers are identified to initiate fires if the primary observers fail to execute.
- Responsibilities for clearance of fires are clearly spelled out.
- Observers know where to position in order to see the trigger and target.
- Use of primary and alternate communications nets.

c. Specialized Conventional Munitions.

(1) **Artillery-delivered smoke.** Artillery-delivered smoke is used to obscure or screen. White phosphorus provides a quick smoke build-up. HC, under the right weather conditions, provides sustained concealment.

(a) Obscuration fire is placed on or near the enemy to isolate the enemy and obscure his view of the battlefield. Because smoke is susceptible to changes in wind direction and the configuration of the terrain, its use must be coordinated with the ATKHB commander and all other friendly units affected by the operation.

(b) Screening fire is used to mask friendly maneuvering elements in order to disguise their operations.

(2) **Illumination.** Illumination is rarely used in current operations due to wash-out of friendly night sight systems. Under certain situations its use may be

FM 1-112

necessary, and you must know and use the correct employment procedures. The following factors should be considered when illumination fires are being employed:

(a) Illumination fires are often necessary to assist aircraft that are not equipped with night observation devices to acquire and engage targets at night.

(b) Since the amount of illumination in basic loads is often low, expenditures must be monitored.

(c) Wind and other atmospheric conditions can affect the time it takes to get effective illumination.

(d) Use of illumination must be coordinated with adjacent units to ensure friendly operations are not degraded.

(3) Scatterable mines. A wide range of FASCAM assets is available to the commander. Artillery-delivered FASCAM, Army aviation- and Air Force-delivered FASCAM, and engineer-emplaced FASCAM can be integrated into the commander's scheme of maneuver in offensive and defensive operations. Each system has different characteristics in terms of patterns, self-destruct times, and responsiveness that must be considered in the planning process. Long self-destruct mines are those that self-destruct in more than 24 hours. Short self-destruct mines are those that self-destruct in less than 24 hours.

(a) FASCAM provides a rapid and responsive obstacle emplacement capability to the aviation brigade. The aviation brigade S3 and aviation brigade engineer plan and coordinate use of FASCAM assets, regardless of the means of delivery. A great deal of planning is required for FASCAM emplacement. FASCAM minefields, like all obstacles, must be tied in with terrain and under observation to be effective.

(b) The supported echelon commander may authorize the ATKHB commander to employ short-duration FASCAM minefields. FASCAM employment is then planned by the ATKHB commander and the S3 in coordination with the supported echelon's engineer, S2, and FSO. Scatterable mines are included in the maneuver and obstacle plan. Upon approval of this plan, the FSO integrates FA delivered scatterable mines into the ATKHB fire support plan. The scatterable mines are then fired as directed by the ATKHB commander.

(c) The standard low-density FA delivered scatterable minefield requires that a total of 30 rounds be fired to form a pattern that is roughly 400 x 400 meters. Employment time is generally 15 minutes (planned) to 30 minutes or longer (unplanned) from the time of the call for fire. Short-duration mines self-destruct in four hours. Long-duration mines self-destruct in 48 hours. Authority to employ long-duration, self-destruct scatterable mines is normally not delegated to battalion level.

(d) A FASCAM minefield is observable on the ground. These mines are most effective when tied into existing or reinforcing obstacles. As with other obstacles, FASCAM minefields must be covered by observation and direct and indirect fires to prevent rapid, unhindered breaching.

(e) The unit that emplaces the mines immediately reports the pertinent information required by the most expeditious and secure means. The report is sent through operations channels to the headquarters authorizing the minefield. The supported echelon then informs higher, lower, and adjacent units of its location.

(f) Aerial employment of scatterable mines may be requested from the aviation brigade. Air VOLCANO can produce two minefields per sortie. The minefields are up to 1,115 meters long and 35 meters wide. The minefields are dispensed with their long axis parallel to the route of flight. If the mines are dispensed from both sides of the UH-60 simultaneously, two minefields will be created, separated by a mine-free strip of ground approximately 50 meters wide. FM 1-113 contains detailed air VOLCANO planning information.

(4) **Laser-guided projectiles.** The COPPERHEAD round is effective against stationary targets out to 5,000 meters from a ground laser designator. Depending on the skill of the operator, a COPPERHEAD round can hit moving targets at 3,000 to 4,000 meters. Aircraft tend to be able to designate from a greater distance than ground/vehicle laser locator designators. However, it takes almost 5 minutes from the initial call for fire for the round to be fired, which limits the utility of this round for targets of opportunity. The requirement for the laser designator to "spot" the target for the final 13 seconds of flight also restricts the utility of this round.

d. **NGF.** NGF can be an effective fire-support means when operations are conducted near a coastline with gunfire support ships within range. US Army units have only a limited organic capability to control naval air or NGF. A US Marine Corps air NGF liaison company normally provides this capability to a division. There are two organizations within the ANGLICO. Depending on which organization is available, the ATKHB will receive either a shore fire-control party or a battalion SALT and firepower control teams. These ANGLICO elements request, coordinate, and control naval air and NGF.

e. **CAS.** CAS is normally planned through FSO channels, to the Air Force TACP located at a ground maneuver brigade, division, or corps head-quarters. CAS and JAAT are discussed indepth in paragraph 3-25 of this manual.

f. **Fire Support Coordinating Measures.**

(1) Fire support coordinating measures are designed to facilitate the rapid engagement of targets and at the same time provide safeguards for friendly forces. Usually, a coordinating measure is recommended by the fire support coordinator, established by the force commander and graphically portrayed on maps, charts, and overlays in the FSE. As a minimum, the measures will provide the following information:

FM 1-112

- A graphic depiction of the measure.
- An abbreviation of the control measure.
- The headquarters that established the measure.
- An effective DTG and termination DTG, if appropriate.

(2) As shown in Table 4-1, fire support coordinating measures fall into two categories--permissive measures and restrictive measures. With a permissive measure, no further coordination is required for the engagement of targets affected by that measure. A restrictive measure imposes certain requirements for specific coordination before engaging targets affected by that measure. Both permissive and restrictive measures are noted in black on situation maps.

Table 4-1. Fire support coordinating measures

| |
|---|
| Permissive measures |
| - Coordinated fire line |
| - Fire support coordination line |
| - Free-fire area |
| Restrictive measures |
| - RFL |
| - RFA |
| - NFA |
| - Formal and informal airspace coordination areas |

(3) Maneuver boundaries serve as both permissive and restrictive measures. They are permissive because they allow maneuver and fire support the freedom to operate without coordination within their limits. However, employment across boundaries requires coordination. The most commonly used fire support coordinating measures are discussed in the following paragraphs.

(a) CFL. A CFL is a line beyond which mortars, FA, and NGF may fire at any time within the zone of the establishing headquarters without additional coordination. A CFL is established at brigade, independent battalion, or higher headquarters. Figure 4-1 shows a CFL.

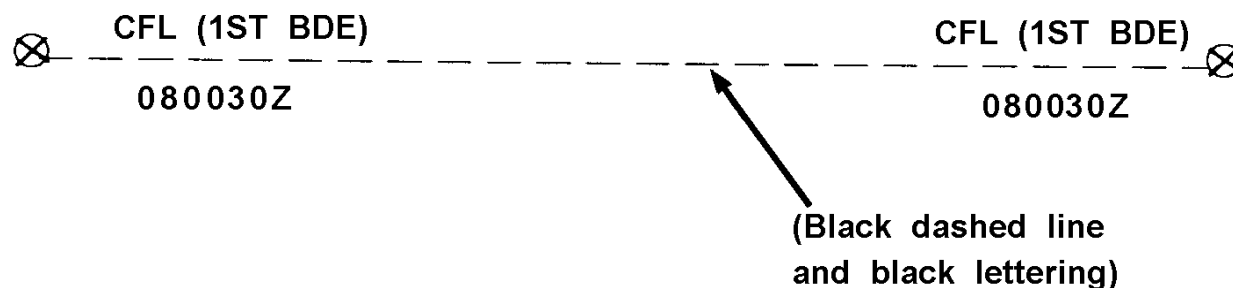

Figure 4-1. CFL

(b) **FSCL.** An FSCL is a line established by the appropriate ground commander to ensure coordination of fires not under his control but which may affect current tactical operations. The FSCL is used to coordinate fires of air, ground, or sea weapons systems using any type of ammunition against surface targets. The FSCL should follow well-defined terrain features. The establishment of the FSCL must be coordinated with the appropriate TACAIR commander and other supporting elements. Forces attacking targets forward of the FSCL must inform the appropriate TACAIR commander and other supporting elements. Supporting elements may attack targets forward of the FSCL, without prior coordination with the ground force commander, provided the attack will not produce adverse surface effects on, or to the rear of, the line. Attacks against surface targets behind this line must be coordinated with the appropriate ground force commander (Figure 4-2).

(c) **FFA.** An FFA is a designated area into which any fire support agency may deliver fires without coordination with the establishing force headquarters. Figure 4-3 shows a free-fire area.

(d) **RFL.** An RFL is a line between two converging forces across which fires may not be delivered without coordination between the affected forces. It is established on identifiable terrain by the common commander of the converging forces. Figure 4-4 shows a RFL.

(e) **RFA.** An RFA is a designated area where specific restraints have been imposed and fires cannot exceed those restraints without approval from the establishing force headquarters. An RFA is established by battalion or an independent company or higher headquarters. Figure 4-5 shows a RFA.

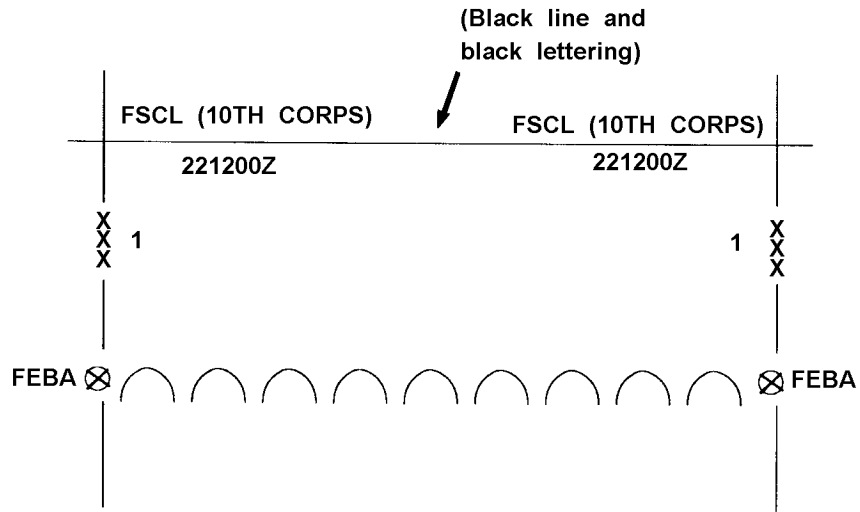

Figure 4-2. FSCL

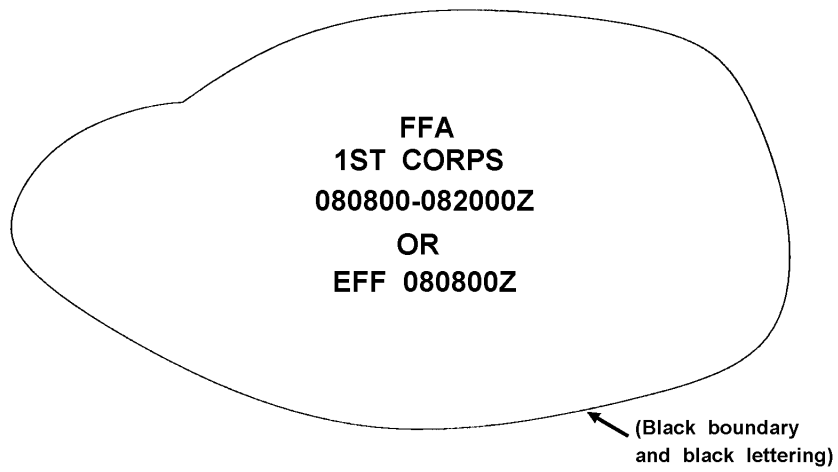

Figure 4-3. FFA

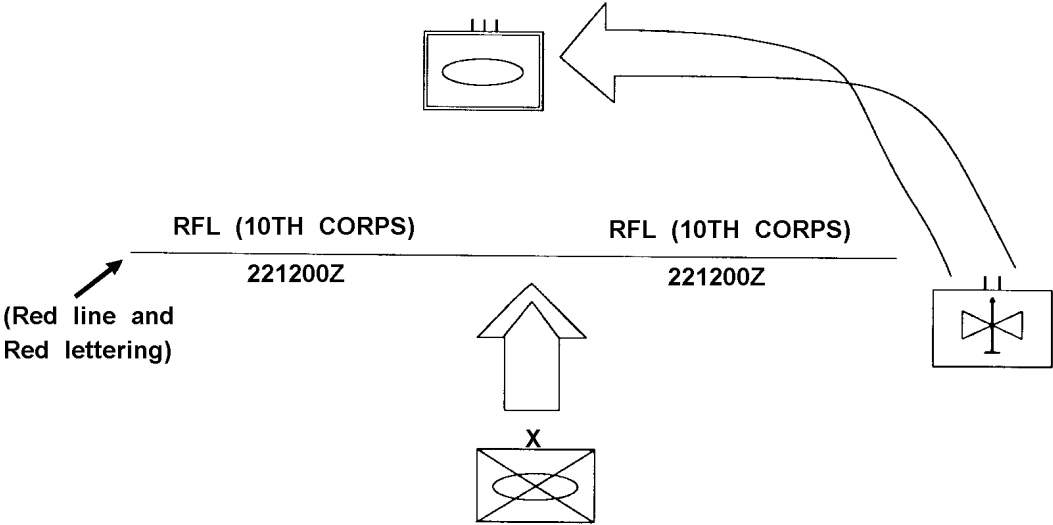

Figure 4-4. RFL

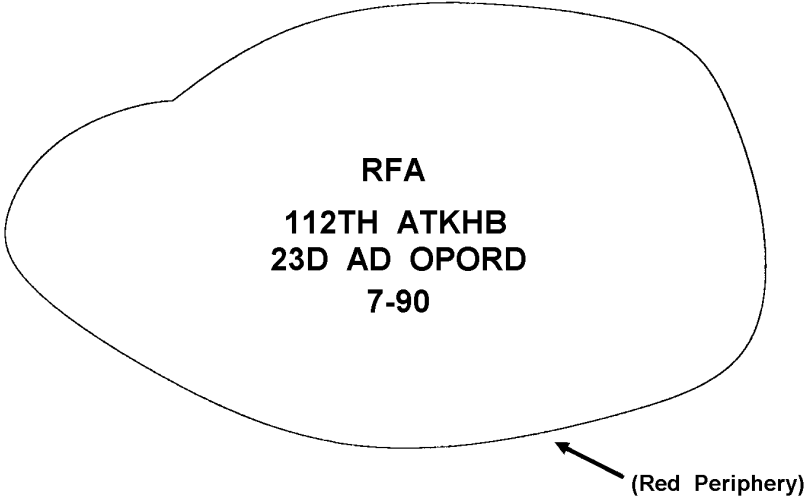

Figure 4-5. RFA

(f) **NFA.** An NFA is a designated area where no fires or effects from fires will penetrate. Figure 4-6 shows a NFA.

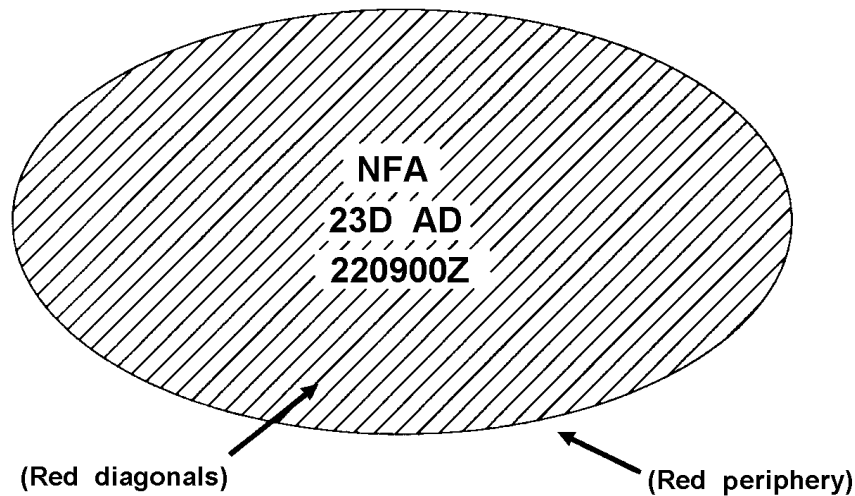

Figure 4-6. NFA

(g) **Informal ACA.** An informal ACA is most often used and is preferred. It can be established at battalion or higher level and is normally not depicted on charts or maps. It can be established by using lateral, altitude, or time separation or any combination of these separations. An informal ACA is normally in effect for a very short time. Usually, the period is only long enough to get aircraft into and out of the target area (3 to 6 minutes). Care must be taken to ensure the temporary ACA does not hinder the conduct of the mission, by stopping the massing of all available fires on the target. In Figure 4-7, CAS fires are permitted only north of the highway and surface-to-surface (for example, FA) fires are allowed only to the south of the highway. The time restriction is 0900 to 0905 and applies to both fire support means.

(h) **Formal ACA** The formal airspace coordination area is a three-dimensional block of airspace in which friendly aircraft can fly without fear of being hit by friendly fire. It is established by brigade or higher headquarters.

4-2. IEW OPERATIONS

a. **General Intelligence.** To defeat the enemy, the ATKHB commander must see the battlefield better than his opponent. He must have a superior knowledge of the enemy, weather, and terrain. The commander gains that knowledge from good all-source

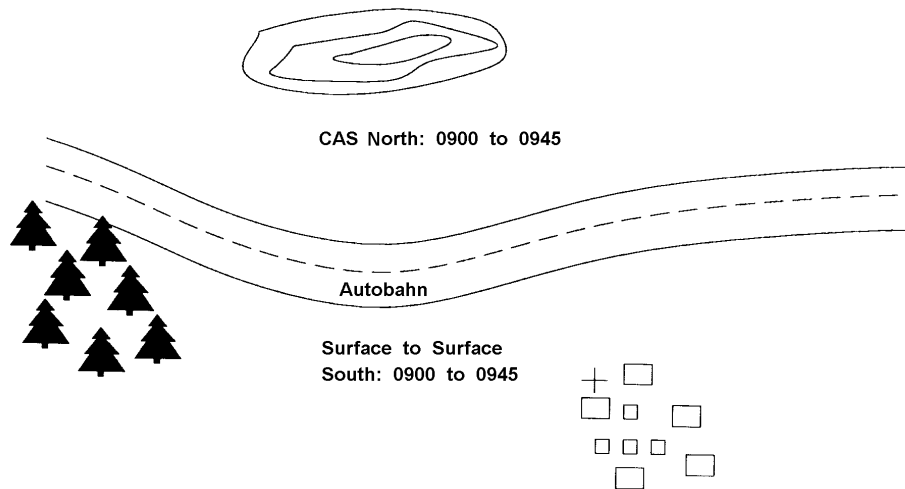

Figure 4-7. Informal ACA

intelligence. For the ATKHB commander to make the most efficient use of his combat power, he must have information concerning enemy dispositions and probable courses of action. The ATKHB S-2 must request support from higher headquarters (HUMINT, SIGINT, ELINT, and overhead photographs) to fill the commander's intelligence requirements. That intelligence helps him make decisions, issue orders, and employ his force successfully on the battlefield.

(1) The ATKHB commander obtains information about the battlefield from higher headquarters and reconnaissance. The ATKHB submits requests for intelligence through intelligence channels. Once the intelligence requests are filled, the battalion confirms and supplements that data with reconnaissance information (obtained from elements in contact, spot reports from ground or air scouts, allied intelligence sources, etc, or from its own reconnaissance of the area, routes, terrain and enemy).

(2) The S2 is the intelligence coordinator for the ATKHB. The S2 gathers, processes, interprets, and passes information to higher headquarters where it is consolidated with intelligence information from other sources and passed to the G2 at division. The G2 disseminates the results as intelligence summaries to provide an intelligence update for units in the division. The S2 also obtains weather information for planning consideration of subordinate units. The S2 and the USAF ALO coordinate the J-SEAD systems.

(3) Intelligence collection requirements are distributed as essential elements of information and other intelligence requirements. Based on the mission, command guidance, and available intelligence, the S2 develops an intelligence COA based on the

FM 1-112

needs of the battalion and higher headquarters. If the commander approves the COA, orders and request are issued to collect information for intelligence production.

b. Electronic Warfare Operations. The enemy will attempt to disrupt and confuse our operations through denial of the electromagnetic spectrum. These operations not only include disruption of communications and identification of friendly forces but also the disruption, deception, and damage of weapon systems. Countermeasures must be used to cope with the enemy's EW capabilities. Further information on electronic warfare is contained in FMs 34-1 and 34-80. To conceal emitters or deceive the enemy as to their identities and locations, the ATKHB commander should--

- Change radio frequencies often.
- Operate radios on the lowest power possible.
- Restrict the use of the electromagnetic spectrum.
- Use wire or cable communications whenever possible.
- Use directional antennae and mask emitters with terrain.
- Train subordinates to act independently in support of the mission and the commander's intent when communications fail.

4-3. AD

The ATKHB has a definite need for protection from enemy air assets. In a mature conflict environment, friendly counterair assets may be unable to maintain air superiority at all times over the battlefield. The ATKHB will take active AD measures by engaging and destroying enemy aircraft with their air-to-air systems, vehicle-mounted weapons, small arms, and supporting AD systems. The ATKHB must also take measures to avoid targeting by enemy air assets through passive AD measures. These measures include camouflage, dispersion, and the reduction of electronic and visual signatures.

a. Active AD. The ATKHB has limited organic AD capability. Although limited to .50 caliber and M60 machine guns with supporting small arms fire, these weapons can make a difference during an air attack. Small arms fires may not destroy attacking enemy aircraft but may distract the pilot enough for him to miss the target. The techniques for leading aerial targets with small arms are described in the STP 21-1-SMCT. Active AD may also be taken by ATKHB aircraft during planned attacks against enemy air assets or through self-protection. FM 1-111 contains additional information on active AD operations.

b. Passive AD. Target detection from the air is difficult. Enemy pilots must be able to see and identify a target to attack it. The effectiveness of enemy high-performance attack aircraft is greatly reduced when the ATKHB takes full advantage of terrain for cover and concealment. Cover and concealment must also be used to protect the battalion

from ground observation. Enemy reconnaissance elements that penetrate friendly lines will be searching for ATKHB assembly areas for targeting by battlefield missiles, tactical aircraft, and artillery. Some passive AD measures are discussed in the paragraphs below.

(1) The ATKHB should occupy positions that offer natural cover and concealment. Coverings should be placed on windshields, mirrors, and headlights of vehicles and canopies of aircraft. Vehicles and aircraft should be parked in tree lines. If this is not possible, aircraft and vehicles should be parked parallel to the tree line and in the shadow of the trees. Cities and small towns offer many areas to hide aircraft and vehicles. They also make it easier to hide the heat signature of an ATKHB. Inhabited areas have an inherent heat signature; wooded areas do not. Equipment should be parked so that it is not silhouetted against the skyline or an area of a different color.

(2) If available, covered, concealed routes should be used when the unit moves. If the unit is attacked while moving, vehicles should be turned 90 degrees from the direction of the attack and keep moving because aircraft normally attack parallel to the movement of the convoy. This countermeasure moves vehicles from the line of fire quickly.

(3) Communications security should be maintained.

(4) Vehicle track marks should be covered around positions. Also, pilots should be aware of the rotor wash path that helicopters leave in loose debris and snow.

(5) Vehicles and aircraft should be dispersed. This not only makes detection more difficult but also ensures that an aircraft making a single pass can attack only one piece of equipment.

(6) Air guards should be posted on vehicles and in dismounted positions to provide a warning of approaching aircraft. These air guards should be rotated frequently because scanning for long periods dulls an individual's ability to spot approaching aircraft. Although the use of vehicle horns is a standard method of warning for an air attack, both visual and audible warning signals should be specified in the unit SOP.

c. **Early Warning.** Accurate and timely early warning allows the supporting AD unit to maximize weapon system engagement capability against the aerial threat and provides the ATKHB the alerting and cuing information to enhance the effectiveness of those active and passive AD measures discussed earlier to protect the force. Early warning sensors are the AD unit's primary resource for locating aerial targets. Many methods are used to pass early warning information. Early warning dissemination requires careful coordination to ensure that the information gets to those who need it, at the proper place and time, and in the proper terminology. Early warning is produced as AD warnings, LADWs, and directed early warning.

(1) **AD warnings.** AD warnings are established by the corps or area AD commander. Authority to declare ADWs may be delegated to corps commanders. When received, ADWs (Table 4-2) apply to the entire force or a specific area and must be

FM 1-112

disseminated to every soldier within the ATKHB. At the brigade level and below, AD warnings are disseminated over redundant nets along with LADWs.

Table 4-2. AD warnings

| WARNING | DESCRIPTION |
|----------------|---|
| RED | Attack or surveillance by hostile aerial targets or missiles is imminent or in progress. Hostile aerial targets or missiles are within a respective area of operations or in the immediate vicinity of a respective area of operations with high probability of entry. |
| YELLOW | Attack or surveillance by hostile aerial targets or missiles is probable. Hostile aerial targets or missiles are en route toward a respective area of operations, or unknown aerial targets or missiles suspected to be hostile are en route towards or are within a respective area of operations. |
| WHITE | Attack or surveillance by hostile aerial targets or missiles is improbable. |

(2) **LADW.** LADW is designed to alert a particular unit, several units, or an area of the battlefield. LADW parallels AD warnings and reflects the local aerial threat. It should be incorporated into SOPs that explain what response is desired by the ATKHB. For example, when dynamite precedes ADW red, the ATKHB may discontinue increasing passive AD measures and engage with a combined arms response. The response desired by the ATKHB is METT-T dependent. (See Table 4-3.)

Table 4-3. LADW

| CODEWORD | DESCRIPTION |
|-----------------|---|
| SNOWMAN | No threatening aerial targets are in the area. |
| LOOKOUT | Aerial targets may be in the area of interest but are not threatening, or are inbound but there is time to react. |
| DYNAMITE | Aerial targets are inbound or are attacking locally now. Response is immediate. |

(3) **Directed early warning.** Directed early warning must be quick, simple, and redundant in nature. It is imperative that each unit within the ATKHB receive early warning. It is especially important when the ATKHB has no AD assets. It states whether the aerial targets are friendly or unknown, provides a cardinal direction,

and if known, identifies the most likely affected asset(s) within the maneuver force. For example, if an early warning source reports four enemy Hinds inbound from the east, and the ATKHB is attacking along the eastern axis, the supporting AD officer/NCO with the ATKHB, aviation brigade, or maneuver brigade in that sector should transmit a LADW message over the appropriate supported maneuver force command net and AD net: "Dynamite! Dynamite! HINDs from the east against Axis Blue!" Dynamite is the LADW that alerts the maneuver force of an attack; the response, according to the local SOP, should be immediate.

d. AD Planning. The commander establishes priorities for AD within the area of operations. If augmented by attached AD assets, the senior AD officer or NCO will provide advice and make recommendations. The commander and S-2 will analyze the area of operation, the terrain, probable intensity and types of enemy aircraft expected, and probable air avenues of approach. He must then balance his analysis of the threat against the available AD weapons supporting his unit. After the commander establishes the priorities, the AD officer or NCO and the S-3 determine the specifics of AD weapon allocation and what positions are to be occupied. The S-3 continues to coordinate and supervise the activities of the supporting AD force throughout the operation. Table 4-4 explains this process.

e. Procedural Control Measures. The procedural control measures governing the employment of AD assets have an impact on ATKHB operations. Procedural control measures are developed through established rules and SOPs. Procedural control relies upon techniques such as segmenting airspace by volume and time, and using weapon control statuses. Procedural techniques are usually more restrictive than positive techniques but are less vulnerable to degradation from electronic or physical attack. The procedural control measures used for AD that affect ATKHB operations include the AD warnings discussed earlier and ROE. ROE include--

(1) Right of self-defense. This right is never denied. The ADA fire unit always has the right to defend itself or its protected asset.

(2) Hostile criteria. ADA squad leaders/team chiefs have both identification and engagement authority. The target must satisfy one or more of the theater hostile criteria. The exact criteria enabling the fire unit to declare a target hostile may vary with the tactical situation. Hostile criteria may include--

- Attacking friendly elements.
- Violating airspace control measures.
- Being visually identified as hostile.
- Responding improperly or not at all to IFF interrogation.

Table 4-4. ADA support relationships

| QUESTION | DIRECT SUPPORT | GENERAL SUPPORT | REINFORCING | GENERAL SUPPORT REINFORCING |
|----------|----------------|-----------------|-------------|-----------------------------|
|----------|----------------|-----------------|-------------|-----------------------------|

FM 1-112

| | | | | |
|--|---|--|--|--|
| Who establishes ADA priorities? | The supported CDR. | The ADA CDR assigning the support relationship, based on the supported CDR's priorities. | The supported CDR through the reinforced ADA CDR. | (1)The supported CDR (2)The supported CDR through the reinforced ADA CDR. |
| Who positions ADA fire units? | ADA fire unit CDRs with approval of the local ground CDR. | The ADA fire unit CDRs in coordination with local ground CDR. | ADA fire unit CDRs with approval of the reinforced ADA CDR and local ground CDR. | The ADA fire unit CDRs in coordination with the local ground CDR and reinforced ADA CDR. |
| Who coordinates terrain on which ADA units will position fire units? | The DS ADA CDR (approved by the supported CDR). | The CDR assigning the support relationship. | The reinforced ADA CDR with the supported CDR. | The CDR assigning the mission with the supported CDR and reinforced ADA CDR. |
| With who should liaison be established? | With supported unit. | With supported unit. | With supported unit but including reinforced ADA CDR. | With supported unit but including reinforced ADA CDR. |
| With whom should communications be established | With supported unit. | With supported unit. | With supported unit but including reinforced ADA CDR. | With supported unit but including reinforced ADA CDR. |
| <p>(1) The term "positions" specifies the selection of the exact placement of individual fire units within the operating area. (2) A unit supporting another unit is responsible for establishing communications with the supported unit.</p> | | | | |

(3) Weapon control status. WCS describes the degree of control for AD fires. The degree of control varies depending on the tactical situation. The corps commander usually has WCS authority for rotary-wing aerial threats. ADA forces must have the ability to receive and disseminate WCS. Weapon control status include--

- Weapons free. Fire at any aerial threat not positively identified as friendly. (This is the least restrictive status).
- Weapons tight. Fire only at aerial threats positively identified as hostile.
- Weapons hold. Do not fire except in self- defense. The term self-defense includes defense of the fire unit, supported unit, and protected asset. This is the most restrictive status.

4-4. ENGINEER SUPPORT

Engineer operations are time and labor intensive. They may not be realistic in ATKHB operations because of the limited number of engineer assets and the number of tasks to be performed. However, the ATKHB must take advantage of obstacles and minefields emplaced for other forces on the battlefield. If engineers are made available to an ATKHB, they can assist in many ways.

a. Mobility. The ATKHB commander must consider how best to use the engineers to increase the mobility of an ATKHB. Possibilities include--

- Constructing LZs, FARPs, and forward AVUM sites.
- Constructing or improving roads into and out of assembly areas and FARPs.

b. Countermobility. Engineers can be used to emplace minefields to fix or turn enemy vehicles in support of the ATKHB attack plan. They also can construct other obstacles in EAs to delay, disrupt, turn or block the enemy.

c. Survivability. Engineers can increase the survivability of the ATKHB by--

- Preparing buildings to house aircraft and equipment.
- Constructing protective positions for aircraft in the assembly areas.
- Constructing protective positions for fuel and ammunition vehicles in the FARP.
- Preparing fighting positions, indirect fire protective bunkers, etc., for personnel.

4-5. NBC SUPPORT

a. NBC Avoidance.

(1) Passive measures. Units must take precautions to avoid being targeted by enemy NBC weapons and to reduce the effect of an NBC attack if one does occur. These precautions include--

(a) Ensuring plans allow for movement and other activity taking 33 percent longer than normal, and effect of fires decreasing by 50 to 70 percent under NBC conditions.

(b) Avoiding detection using OPSEC.

(c) Providing warning to subordinate units through emphasis on detection and rapid reporting.

FM 1-112

(d) Maintaining discipline after the attack. Units must be conditioned mentally and physically to stay in MOPP gear until told to reduce the MOPP level. Units have experienced problems at CTCs when leaders delegate unmasking authority below battalion level. Even though companies have M256 kits that indicate the area is clear, only the battalion chemical section has enough information to allow the commander to assess the risk and make the decision to unmask.

(e) Taking advantage of natural terrain for protection. Ditches, ravines, wadis, and natural depressions reduce the effect of nuclear attack, but chemical agents accumulate in these areas. Heavy forests and jungles protect against liquid chemical agents, but chemical vapors tend to accumulate there.

(f) Dispersing subordinate units as much as tactically feasible. Leaders should organize support units into bases no larger than company size. When possible, supplies should be kept at more than one location so they can not all be destroyed at once.

(g) Frequent movement of likely targets (reserves, supply bases, etc.).

(h) Storing supplies and equipment under cover to prevent contamination. Soldiers can use tarpaulins, plastic sheets, canvas, cardboard, dunnage, and any other readily available material to protect equipment for a short time or reduce contamination.

(i) Avoiding operations in contaminated areas when possible. Leaders often encounter problems when they neglect quick decontamination and continue a mission in MOPP 4. Leaders must continually balance the trade-off between a short-term mission degradation for decontamination with more sustained long-term performance, or continuing to perform the mission by foregoing decontamination with the resulting long-term ineffectiveness of the unit.

(j) Preventing the spread of the contamination by limiting the number of elements moving into the area, and decontaminating units that leave a contaminated area so they do not spread the contamination into a clean area.

(2) NBC reconnaissance.

(a) Leaders should view contaminated areas as obstacles that, when possible, should be bypassed. If he does not have a choice and must go through the contaminated area, the element discovering the contamination should attempt to describe to him the depth and type of agent. With this information, leaders at all levels can adjust their plans accordingly.

(b) The technique for reconnoitering a contaminated area is the same as a minefield. The IPB process determines where the enemy will probably employ chemical agents and where chemical agents will collect (low spots, small valleys, and sheltered locations). These are marked as NAI. Units not in a named area of interest conduct tests for liquids from the ground or vegetation using M8 detector paper every 500 meters. Once

in the NAI, units conduct liquid tests as before but also conduct vapor tests with the M256 kit, or if unavailable or time is not available (it takes 16 minutes to test for all three types of agent), with the M8A1. When the unit detects chemical agents, they will report, mark the area, and move back to the spot where they received a clean reading. They will then move laterally 500 meters and then forward again. Units conduct radiological reconnaissance in the same fashion using dose rate equipment to identify areas with high dose rates. Only NBC reconnaissance teams are capable of reconnoitering for and collecting biological agents.

(3) Detection.

(a) Detection is an essential step of NBC defense when leaders expect the enemy to use NBC weapons. The battalion has a variety of equipment that can detect, locate, and measure NBC contamination (see Table 4-5).

Table 4-5. Detection equipment in the ATKHB

| EQUIPMENT | WHAT IT DOES | | | WHAT TYPE OF CONTAMINATION | | | |
|-------------------------|--------------|--------|---------|----------------------------|-------|---------|-------|
| | DETECT | LOCATE | MEASURE | NUCLEAR | NERVE | BLISTER | BLOOD |
| IM/174-Series Radiac | X | X | X | X | | | |
| AN/PDR 27-Series Radiac | X | X | X | X | | | |
| M8-Series Alarm | X | | | | X | | |
| M8 Paper | X | X | | | X | X | |
| M9 Paper | X | | | | X | X | X |
| M256 Kit | X | | | | X | X | X |
| Chem Agent Monitor | X | X | X | | X | X | |

(b) Units must employ M8 alarms, M8 paper, and M9 paper after a suspected chemical attack. This is especially true when moving from the initial position to a subsequent position.

(4) Marking. The unit conducting the NBC reconnaissance or that detects contamination should mark entry points to contaminated areas. Marking is described in detail in FMs 17-98 and 3-3.

(5) Reporting.

FM 1-112

(a) Reporting is a critical part of NBC operations. Reports must be forwarded to the brigade-level headquarters. They must be in proper format and given widest dissemination and coordination possible.

(b) NBC reports are as time sensitive as spot reports. The SOP for reporting and dissemination of NBC information must be streamlined and effective. One technique is for companies to submit only one NBC-1 report to the battalion. All other companies and stations acknowledge the report and simply indicate whether they are also under attack. The battalion chemical section then knows the full extent of the attack without the command net being cluttered by NBC-1 reports from every company and out station. If a unit is under attack by a different agent, it sends a complete NBC-1 report.

(c) Staff sections and LNOs representing supporting elements are critical links in the dissemination process. These elements should disseminate reports to the units they represent and coordinate for if they are not on the command net of the battalion.

(d) It is difficult if not impossible for pilots to plot NBC-1 reports while flying. One technique is to identify prominent features such as ridgelines, roads, or rivers as boundaries to contaminated areas. Another technique is to identify grid squares that are contaminated.

b. Decontamination.

(1) Decontamination fundamentals.

(a) In the past, Army doctrine dictated that when a unit became contaminated, soldiers stopped fighting, pulled out of battle, and found a chemical unit for the cleanup. Current doctrine supports fighting while contaminated and conducting hasty decontamination along with natural weathering to reduce chemical or biological hazards.

(b) The commander uses the factors of METT-T and some additional considerations to determine when, where, and how to conduct decontamination. When planning operations, commanders should ask these questions--

- How long have personnel been operating in MOPP gear?
- What missions are planned in contaminated areas?
- What are the capabilities of NBC personnel and the decontamination team?
- What external support is available from chemical units?
- What decontamination support will the supported unit provide?

(2) **Decontamination principles.** The four principles of decontamination are as soon as possible, only what is necessary, as far forward as possible, and prioritized.

- (a) Decontaminate as soon as possible.
- (b) Decontaminate only what is necessary to free assets for immediate operations.
- (c) Decontaminate as far forward as possible.
- (d) Decontaminate by priority. Prioritize units based on how critical that unit is to the mission.

(3) **Levels of decontamination.** The two levels of decontamination are partial and complete.

(a) **Partial.** Partial decontamination is removing or neutralizing just enough contamination to sustain operations.

(b) **Complete.** Complete decontamination is reducing contamination to a level that permits soldiers to operate for extended periods without wearing a mask or protective gloves.

(4) **Types of decontamination.** There are three types of decontamination. Individual soldier skills (aircrew decontamination) and hasty decontamination operations achieve partial decontamination. Deliberate decontamination operations achieve complete decontamination.

c. **Aircraft Decontamination.** The sensitivity of aircraft components to caustic solutions has driven the development of special decontamination procedures. Commanders must combine these special procedures with decontamination principles and determine where and when to conduct decontamination operations. Spot decontamination is the most time-effective technique and will limit the spread of agents. Units may find that aircraft decontamination is not time-effective when aircraft are in great demand. Because aircrews will be required to fly in MOPP 4, commanders must determine effects on the mission.

(1) **Decontaminants.**

(a) Only approved cleaning compounds may be used to decontaminate aircraft. Caustic decontaminants, such as DS2, STB, bleaches, or sodium hypochlorite, are not considered safe.

(b) Soap and water, kerosene, JP8, and diesel fuels are approved as decontaminants on selected parts of aircraft. JP8 is effective in removing some agents from aircraft skin and components, but will not neutralize the agents. If water is available, it should be used to rinse off the JP8.

(c) When components are removed from the aircraft for repair, some caustic chemical may remain. Maintainers must decontaminate these components before

FM 1-112

cannibalization or overhaul. Once components have been decontaminated, personnel must rinse the components thoroughly before they are reinstalled on the aircraft.

(d) Actual flight and aeration can help decontaminate external surfaces.

(e) Soldiers must be careful when using pressurized water for decontamination. Aircraft skin and internal components can be damaged by moderate to high water pressures.

(2) Decontamination techniques.

(a) **Spot decontamination.** The goal of spot decontamination is to limit the spread of contaminants by removing most of them from selected areas of the aircraft. Fuel and soap and water are the most common decontaminants.

(b) **MOPP gear exchange.** In a contaminated environment, MOPP gear exchange and rest and relief operations must be conducted. Every soldier must know how to change his MOPP gear to survive. When the mission allows, aircrews may return to a unit decontamination area for the exchange.

(c) **Aircraft washdown.** Aircraft washdown is the same technique as vehicle washdown and includes detailed, time-consuming procedures for both exterior and interior decontamination. Units are encouraged to develop site layouts in conjunction with chemical units that are appropriate for their specific missions and the terrain.

(d) **Decontamination.** Decontamination sites are established by chemical units, usually in the rear areas. The supported units conduct their own personnel and equipment decontamination. The chemical unit decontaminates vehicles, provides technical assistance and supervises the entire site. Aviation units must be thoroughly familiar with their responsibilities at these sites.

(3) Hasty decontamination operations.

(a) **Arming and refueling operations.** All areas that FARP personnel touch should be decontaminated.

(b) **Entry and exit procedures.** During training, commanders should outline entry and exit procedures for all types of aircraft. FARP personnel must become familiar with the procedures. Aircrews should signal the FARP personnel if they intend to exit the aircraft. FARP personnel can then decontaminate most areas that the aircrews will touch on exiting the aircraft. Aircrews should attempt to limit the amount of contamination transfer by using contamination avoidance measures. Before entering the aircraft, aircrews should use an M258A1 kit to decontaminate their gloves and overboots.

(c) **Preflight and postflight inspections.** When conducting preflight and postflight inspections on contaminated aircraft, aircrews must try to avoid becoming

contaminated themselves. Spot decontamination helps reduce this possibility. Aircrews may need to wear wet-weather clothing to keep most of the contamination off the overgarment.

(d) **Maintenance inspections.** Personnel may conduct maintenance inspections before or after decontamination of the aircraft. Inspection crews use the decontamination techniques discussed in paragraphs (2) and (3) above to avoid spreading contamination.

(e) **Repair or recovery.** Repair or recovery crews should be aware of the contamination level before they enter the area. Teams will evaluate the situation to determine when or if an aircraft component can undergo decontamination. Some items may be decontaminated before they are returned to the maintenance section if the maintenance area is clean. However, if the maintenance area is contaminated, decontamination should occur there.

(f) **Cannibalization and overhaul.** The same decontamination considerations of clean versus contaminated aircraft and components also apply to cannibalization and overhaul maintenance activities.

d. **Aircraft Decontamination Stations.** Normally, the ATKHB conducts hasty decontamination, but it may conduct a deliberate decontamination if the situation requires it and time is available. Decontamination operations are normally conducted at battalion level and require an area that meets the appropriate criteria.

(1) **Site selection requirements.** The decontamination site must accommodate the required aircraft, have a readily available water source, and allow for adequate drainage. The site should be planned using the guidelines for an FAA. Tentative decontamination sites must be considered and integrated into the tactical plan as are tentative CP and FARP sites.

(2) **Station layout.** Any of several techniques may be used to decontaminate aircraft. An effective method is the one-step method. In this method, companies are sequenced into a particular area, shut down, decontaminated, and returned to duty. The battalion is responsible for selecting and securing the site as well as augmenting chemical personnel. The chemical unit is responsible for operating the site. As each company-level unit is sequenced through the station, the remaining companies provide security. After aircraft are shut down, the entire aircraft or specific areas are washed with hot, soapy water and rinsed. If available, hot air may be used to dry the aircraft and decontaminate the interior or otherwise sensitive areas of the aircraft. This sequence is continued until all battalion elements have completed the decontamination. The site is then cleared and the battalion continues its mission.

(3) **Safety precautions.** Site safety principles are similar to those practiced in the FARP. The ASO should develop an annex to the safety SOP addressing decontamination site specific factors.

(4) Alternate site layouts. Units must establish their own site procedures and equipment requirements. Alternate sites should be considered during the planning phase of battalion operations, particularly decontamination operations. See FM 3-5 for sample alternate site layouts.

e. FARPs.

(1) Aircrew support. If FARPs are near or collocated with other units that have NBC support, NBC support for the aviation elements may be arranged with those units. In a CB environment, clean and contaminated FARPs may be established to facilitate rapid relief-on-station operations and prevent repetitive contamination. The mission and temperature will determine how often the crews visit a rest and relief station. If additional aircrews are available and the mission allows it, a crew change during rest and relief could make aircraft available for more missions.

(2) FARP NBC planning. Detailed planning is the key to successful FARP operations in an NBC environment. Because FARPs are vital to the aviation mission, commanders should answer the questions below to assist in planning FARP operations.

(a) How will friendly STRIKWARNs be passed to FARPs and to aircraft being serviced at the FARPs?

(b) Is the use of smoke planned to lessen FARP vulnerability during site preparation and closure?

(c) Is at least one member of the FARP trained in the two considerations above?

(d) Who estimates the dosage when the FARP is operating in a radiological contaminated area? How will this dosage estimate affect operational planning?

(e) Are FARP personnel aware of nuclear damage to aircraft? Can they identify nuclear damage to armament systems?

(f) Do FARP personnel know how to minimize nuclear blast effects and thermal damage to fuel blivets and other FARP equipment?

(g) Will the supported or parent unit assist in decontamination?

(h) Who provides guidance to FARP ground personnel concerning the best routes through or around contaminated areas?

(i) What visual or radio communications can FARP personnel use to warn an incoming aircraft that a FARP site is contaminated? Also, how does an aircrew warn FARP personnel that the aircraft is contaminated?

- FARP?
- (j) In a chemically contaminated area, who should dismount at the FARP?
 - (k) If aircrews dismount, what provision is made for spot decontamination to lessen the transfer of contamination?
 - (l) What provision is made to keep contamination out of the cockpit (especially that carried in on boots) when aircrews enter the aircraft?
 - (m) During missions, how can FARP personnel wearing MOPP 4 gear keep up with the work load? What plans are made for rest and relief or assistance?
 - (n) When JP8 is used as a spot decontaminant, are personnel trained in its hazards?
 - (o) Are FARP personnel trained to use covers in a manner that does not create FOD hazards?
 - (p) Are FARP personnel prepared to accept supplies that are contaminated?
 - (q) What personal needs are provided for aircrews at the FARP?

f. Aircraft Maintenance. In an NBC environment, maintenance operations will be affected more by nuclear detonations than by chemical or biological agents. Nuclear detonations will cause greater structural and component damage than conventional explosions. While CB agents create a lethal environment for personnel, they do not normally damage aircraft components or airframes.

g. A²C². A²C² elements must work closely with NBC elements or control centers. STRIKWARNs may be passed through A²C² networks as well as units. Planners must use NBC contamination information and friendly nuclear minimum safe distances to establish air corridors.

h. Survivability.

(1) Radiological contamination. Crews surviving a nuclear attack should be alert for forest fires or other fires caused by thermal radiation. Radiological contamination, however, will be the aircrew's most significant hazard. If the aircraft goes down in a fallout area or the crew receives fallout, the dose rates can be high enough to cause casualties. Each aircraft should have an IM93 or a DT-236 to measure the total dose received by the aircrew.

(2) **Radiological particle ingestion.** If the situation permits, the crew should attempt to dig a deep fighting position or find cover such as a cave or an abandoned armored vehicle. Living off the land will pose long-term hazards from the ingestion of radiological particles. The best preventive measure for this is to wash the food. Heat will not reduce any radiological hazard. Running water will dilute radiological agents and reduce the risk of drinking contaminated water.

(3) **Lethal chemical agents.** In a lethal chemical environment, surviving personnel will be faced with many additional hazards. When the situation permits, the crew should readjust the CB protective gear and take action to find out if the area is contaminated. If personnel do not have another set of MOPP gear, they should not remove the gear they are wearing. If a second set of MOPP gear is available and the situation permits, the crew should change into the new clothing.

i. Smoke Operations.

(1) **Smoke effects.**

(a) Smoke is more effective when it is used at night or with natural obscurants such as fog, rain, natural dust, or battlefield dust and debris. Smoke is the one obscurant that can be placed, within meteorological constraints, where the user wants it.

(b) Smoke is a suitable medium for hiding and dispersing CB agents. These agents may include irritants such as riot control agents, incapacitants, and lethal CB agents. Smoke will prolong the life of CB agents by reducing the effects of sunlight or other weather conditions on agent persistency.

(c) Smoke makes it difficult to see the target. The extent of visual difficulty depends on the type of smoke used and its mixture with natural obscurants. The enemy may possess smokes that deny visual identification and adversely affect light-intensifying devices and near-infrared devices. Mid- to far-infrared devices, thermal imaging, and heat seekers are degraded when the contrast between the target and the background is reduced. The extent that a laser can be degraded depends on the energy of the laser; the lower the energy, the more the laser can be degraded. Large dust storms can adversely affect enemy acquisition systems. Many armored vehicles can employ self-screening smokes during road movement.

(d) FSU doctrine regarding smoke emphasizes the employment of smoke with other decoy or deception operations. Smoke draws attention to a general area, but the observer must determine where the unit or target is in the smoke and whether the smoke really hides targets.

(2) **Smoke employment.**

(a) **Enemy employment.** When an enemy employs smoke against US maneuver forces, aviation missions must increase to assist with observation and C².

When employed on terrain features, smoke can force aircraft up and into enemy AD coverage. Smoke denies low-level corridors or possible LZs for air assault operations. Large area smoke can obscure terrain features that serve as NAVAIDS. Silhouetting aircraft against smoke increases their vulnerability. Smoke employed on ground-based aviation support units, such as FARPs and maintenance, will disrupt aviation operations.

(b) United States employment. United States forces can employ smoke to keep the enemy from observing and acquiring them. FM 3-50 discusses smoke employment. When U.S. forces employ smoke on enemy forces, their ability to observe and acquire targets will be affected. Smoke draws attention, so aircrews may tend to concentrate more on the smoke than on the targets. Aircrews may have difficulty seeing targets in the smoke or seeing targets leave the smoke. When a ground vehicle leaves a smoke screen, it is easier to acquire because it is silhouetted against the smoke. Aircrews must be aware of how smoke affects their ability to see enemy targets.

j. Aircrew Training for NBC Operations. Aircrew training should be conducted in two phases--the ground phase and the air phase. The ground phase acclimatizes aircrews and ground personnel to wearing MOPP gear. The air phase is more flexible; commanders must determine how much of their units' flight time they can devote to NBC training. The concepts presented here can be applied to ground crews as well as aircrews.

(1) Ground phase.

(a) Acclimatization must be accomplished gradually, and once completed, it must be maintained. Therefore, before aircrews fly in MOPP 4, they should be able to operate in MOPP 4 on the ground for a minimum of six hours without interruption. This figure is a guideline for the commander. When aircrews enter into the ground phase of training, they should understand that the purpose of the training is twofold. First, it allows them to acclimatize to the protective clothing. Second, it gives them an idea of their personal limitations. For aircrews to realize their personal limitations, they must conduct the same activities they normally do in an uncontaminated

FM 1-112

environment. The commander must stress this, because all activity does not cease when the unit goes into MOPP 4. Normal operations include--

- Drinking.
- Flight planning.
- Preflight checks.
- Mission briefings.
- Basic personal hygiene.
- Operation overlay construction.
- Routine maintenance such as scheduled or run-up maintenance.
- Cockpit procedures such as tuning radios, adjusting switches, or completing checklist items.
- As individuals progress through the ground phase, they will identify those areas that affect them the most.

(b) After determining their limitations, individuals can find new ways in which to accomplish the task or modify existing procedures.

(2) **Air phase.** Flight time is a valuable asset to every unit. Although the air phase can be done during existing training, simulations should be considered to indoctrinate crews into MOPP 4 operations. General goals are recommended below, but the actual method to reach these goals is left up to the commander. The recommended goal for individuals is six continuous hours of operating in MOPP 4 gear. The goal for units is 48 continuous hours of operating in a simulated NBC environment.

(a) For training to be realistic, commanders must rotate unit personnel, as they will in combat, through collective protection shelters. If enough shelters are available, 50 percent of the unit may be participating in rest and relief at any one time. Accordingly, unit effectiveness and mission accomplishment will be proportionally degraded. To achieve acceptable performance levels, commanders may have to move all or part of their units to a clear area.

(b) When implementing training programs, commanders should gradually increase the time that aircrews fly in MOPP 4 over a given period. However, the training must be in line with individual crew member capabilities and safety requirements. Commanders should refer to the scheduling guide in AR 95-1 when developing crew work and rest schedules.

k. Training Considerations. As with all training, the aircrew training program should be carried out aggressively and consistently in a realistic manner. However, commanders should remember that safety should never be sacrificed for realism. With this in mind, unit trainers and commanders must be aware of certain factors that will affect their units' success in carrying out their training program. Some factors are described below.

(1) Ambient temperatures and humidity may be very high, thereby increasing the wet bulb globe temperature. Unit SOPs should specify that every soldier must be familiar with the symptoms of heat stress and other heat-related injuries. Early morning and late evening hours are the best times to conduct NBC flight training because of the lower temperatures and decreased humidity.

(2) AR 95-1 specifies the flight uniform requirements for aircrews. TC 1-210 specifies safety requirements for MOPP training. Aviators not on the controls must recognize when aviators on the controls begin to lose concentration so that they can take control of the aircraft. Every individual has a different physiological makeup; therefore, commanders should not expect every crew member to progress at the same rate.

(3) Overall physical conditioning plays an important role in an individual's ability to perform in MOPP gear. Commanders should ensure that their units pursue an aggressive and challenging program of physical training along with MOPP training.

CHAPTER 5

COMBAT SERVICE SUPPORT

Successful ATKHB operations will depend on close staff coordination. The battalion staff must anticipate and coordinate ATKHB CSS with higher echelon CSS. Under the direction of the battalion XO, the S1 and S4 coordinate supply, maintenance, PSS, and health service activities with the S-3 and S-2 to support combat operations. The ATKHB depends on CSS from its parent aviation brigade, the DISCOM, and the COSCOM. The principles and doctrine for CSS planning are described in general terms in FM 100-10. Corps and division CSS doctrine is contained in FM 63-3 and the FM 63-2 series manuals. General CSS planning principles as related to aviation operations are discussed in FM 1-111.

5-1. PLANNING AND COORDINATION

a. Planning. Combat operations and CSS planning must be conducted at the same time. The ATKHB commander relies on the S3 to employ his unit and the S-1 and the S4 to support it. Successful ATKHB combat operations require timely reports that reflect the CSS status of the battalion. Unlike other maneuver forces, the ATKHB can be employed anywhere within the division's or corps' area of operations. The ATKHB coordinates its support through the aviation brigade to the DISCOM/COSCOM that designates the ASB, a FSB or the MSB as the primary support facility. To ensure the availability of CSS, the DISCOM/COSCOM, aviation brigade, and ATKHB commanders must maintain close coordination.

b. Coordination. Depending on the environment and the mission, attack helicopters will require fuel and ammunition resupply after every 1 1/2 to 2 hours of continuous operations. The battalion staff must forecast support requirements based on the expected duration of the mission. Requirements are processed through the brigade staff and then sent to the DISCOM/COSCOM. The DISCOM/COSCOM staff directs support to the ATKHB from the appropriate DISCOM/COSCOM unit. In divisions without an ASB, the DISCOM/COSCOM unit or units that support a ground maneuver brigade FSB and the division main support area must be prepared to support the ATKHB. Successful ATKHB missions will depend on how well Classes III and V and aircraft maintenance, recovery, and evacuation are integrated into the tactical plan.

5-2. FUEL AND AMMUNITION REQUIREMENTS

Fuel (Class III) and ammunition (Class V) are two of the three primary classes of supply used by the ATKHB for the conduct of combat operations. The planning considerations, resupply request procedures, and estimation supply and transportation requirements for both classes of supply are discussed in detail in FM 1-111.

FM 1-112

a. Fuel. Fuel transportation requirements for a mission are determined by subtracting the total fuel in mission aircraft fuel cells from the total fuel required to complete the mission. By comparing these figures to the capacity of available fuel trucks, the total number of trucks required can be calculated. FM 1-111 provides an example and the necessary information for calculating fuel transportation requirements for all types of ATKHBs.

b. Ammunition. FM 1-111 provides an example of the estimation of ammunition required and transportation requirements for one day of ATKHB operations. The total transportation requirement will equal the sum of the vehicles required to carry each type of ammunition. Ammunition shortfalls must be identified early so that the ATKHB can preposition supplies or request transportation support to ensure a steady flow of ammunition during the mission.

5-3. FARPs

a. FARPs are the primary means of supplying the ATKHB when it is employed forward. They allow the commander to position fuel and ammunition forward to support his unit. The battlefield is nonlinear and constantly changing. Each FARP must be austere, transitory in nature, and established to support specific mission objectives. Once committed, the FARP must be able to meet the Class III and V needs of all mission aircraft and provide limited maintenance and medical capability. It also must be large enough to rearm and refuel a company of attack helicopters simultaneously. The sole function of the FARP is to provide the commander with the means to reduce turnaround times.

b. The staying time of the ATKHB is increased in proportion to the decrease in turnaround time for Class III and V supplies. Reducing turnaround time enables the commander to apply continuous pressure on the enemy. Actual and proposed FARP locations must be on all division and below graphics, and locations must be coordinated to keep mechanized and armor formations from rolling through them. FM 1-111 provides an in-depth discussion of the employment of a FARP (or FARPS) on the battlefield.

5-4. VEHICLE AND GSE MAINTENANCE

The HHC maintenance section provides unit-level vehicle maintenance for all ATKHB vehicles and GSE. The DS maintenance company of the DISCOM or COSCOM provides vehicle DS maintenance and repair parts support. FM 1-111 discusses these different levels of support in detail.

5-5. AIRCRAFT SUPPORT

Like fuel and ammunition, maintenance and recovery of aircraft are critical to combat operations. AVUM and AVIM companies are normally located far enough to the rear of the division or corps that light sets can be used to facilitate 24-hour maintenance operations. The location of these companies should facilitate coordination and the receipt

of logistics support from other agencies in the theater. When equipment cannot be repaired on site, it is moved only as far as necessary to affect repair.

a. Maintenance.

(1) **AVUM.** To repair and return aircraft to a serviceable condition rapidly, the AVUM company performs unit-level maintenance actions such as repairs by replacement, minor repairs, and adjustments. Today's modern attack helicopters concentrate system repairs on the use of line replaceable units. This allows the AVUM to isolate a fault and when possible, change out the identified component and return the aircraft to a FMC status. AVUM is governed by maintenance allocation charts and limited by GSE, facilities, and the number and skills of available maintenance personnel. The most critical area of unit maintenance is line-company crew chief support of the aircraft. The crew chief is the only maintenance person who has daily contact with the aircraft. Preventive maintenance and fault detection originate with the crew chief.

(a) **Personnel.** Aircraft maintenance support personnel in the ATKHB are located in the three attack companies and the AVUM company. Organization and personnel assignments are driven by airframe allocation. Figure 5-1 shows the organization of the AVUM company.

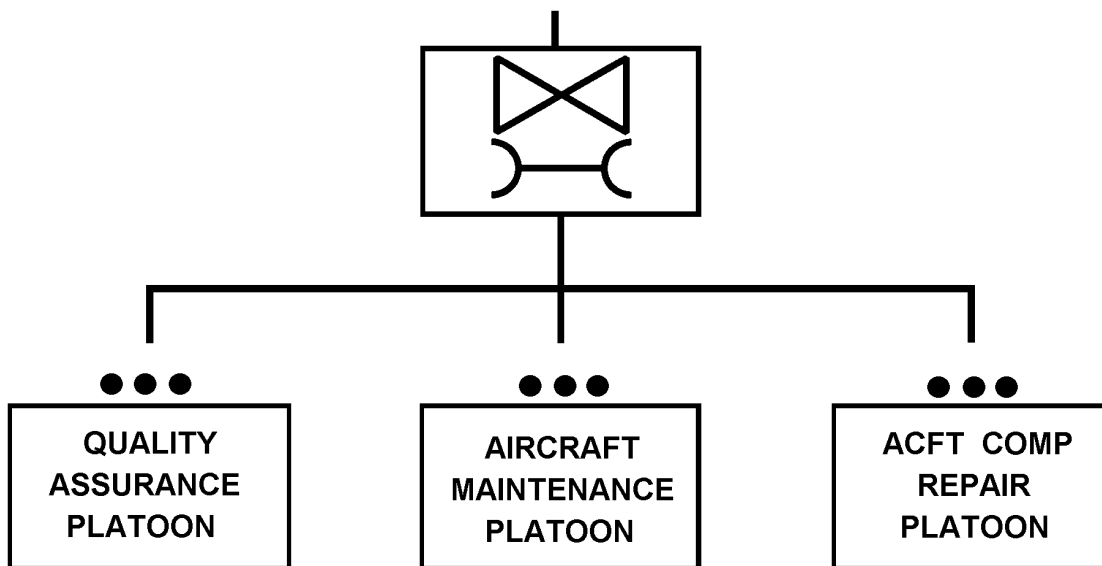

Figure 5-1. AVUM company organization

FM 1-112

(b) **Responsibilities.** The AVUM company conducts preventive maintenance, repair, and parts replacement. It also identifies causes of malfunctions and evacuates unserviceable modules, components, and end items. AVUM operations and responsibilities are discussed in detail in FM 1-111.

(2) **AVIM.** The divisional AVIM company is a separate company that is organic to the DISCOM and structured to support the specific aircraft assigned to the division. In some divisions, the AVIM company may be organized into the ASB. The composition of this battalion is highlighted in FM 63-23. The AVIM company is designed to provide AVIM-level maintenance and backup support of unit maintenance at its base in the DSA. The AVIM company performs extensive maintenance activities which include structural and airframe repairs, support of the repairable exchange program, and AVIM-level maintenance. The AVIM company also maintains division Class IX (air) repair parts supply and provides supply support to division aviation units. Nondivisional AVIM companies in the corps and theater areas provide support for their area's aviation assets and backup support for the divisional AVIM companies. Additional information on AVIM structure and responsibilities are discussed in FM 1-111.

(3) **Communications maintenance.** The HHC communications section provides unit-level communications maintenance; the AVUM company provides avionics maintenance for ATKHB aircraft.

(4) **Armament maintenance.** The ATKHB aircraft component repair section performs unit-level armament maintenance. Its capabilities are limited to detection, fault isolation, and evacuation of major components and LRUs or "black boxes." AVIM armament support is provided at the DISCOM or the COSCOM, depending on whether the ATKHB is a division or a corps unit.

b. **Recovery.**

(1) **Aircraft.** The AVUM company of the ATKHB conducts aircraft recovery within the limits of its organic capability. The AVUM company should prepare for aircraft recovery contingencies by forming an aircraft recovery team. The aircraft recovery team is composed of personnel and equipment necessary to prepare an aircraft for recovery. Supporting AVIM units, coordinated through aviation brigade, provide additional recovery support when recovery is beyond the capabilities of the AVUM company. The decision to recover downed aircraft will depend on the tactical situation and the availability of personnel and equipment necessary to recover the aircraft. FM 1-111 discusses aircraft recovery planning and execution in detail.

(2) **Ground vehicles.** The ATKHB recovers and moves its own ground vehicles. When unable to do so, it receives assistance from DS maintenance units. FM 1-111 discusses vehicle recovery in detail.

5-6. TRANSPORTATION REQUIREMENTS

The ATKHB is primarily independent of external transportation requirements. The MTOE of the ATKHB is designed in such a manner as to preclude the necessity for such assets. The primary user of such assets, the AVUM Company, will only move when the battlefield increases in depth and requires the entire division support base to extend its area. The focus of ATKHB operations is to operate as far forward as possible with all combat power and maintain the security of the AVUM. FM 1-111 discusses aviation unit transportation preparation and planning in detail.

5-7. PERSONNEL SERVICES

Personnel assigned to the personnel and administrative center perform PSS functions. To reduce the administrative burden on the ATKHCs, PAC accomplishes as many support actions as possible. Personnel services support functions fall into two general categories--critical personnel functions and essential personnel functions. Critical functions, such as strength accounting, replacement operations, and casualty reporting, must be performed regardless of combat intensity. On the other hand, essential functions can be curtailed or suspended at battalion level during intense combat. During combat or preparation for combat, priority must be given to the critical PSS functions. FMs 1-111 and 100-10 discuss each of these areas.

a. Critical Personnel Functions. To maintain battalion strength, specific actions must be taken. These actions are discussed in the paragraphs that follow.

(1) Personnel accounting and strength reporting. These actions include updating the unit battle roster, which is based on duty positions from the unit table of organization and equipment and preparing and forwarding the personnel status roster. The personnel status roster is submitted daily and after significant changes in unit strength.

(2) Replacement operations. These actions include assigning replacements based on critical leadership and WSRO assignments. They also include performing administrative and personnel actions such as signing in personnel; preparing SIDPERS transactions; updating battle rosters; and briefing replacements on the tactical situation, unit SOPs, and facility locations.

(3) Casualty management and casualty operations. These actions include reviewing casualty feeder reports and witness statements for completeness and accuracy, checking the battalion aid station casualty treatment log to ensure all casualties have been reported and forwarding the casualty report.

(4) CHS.

(a) Unit-level HSS elements have the primary mission of preventing illness, providing emergency and routine medical treatment, and medically evacuating the

FM 1-112

sick, injured, and wounded. Medical personnel are responsible for supervising the training of first aid, buddy aid, and combat lifesaver skills. Additionally, medical personnel provide assistance in preventive medicine measures such as field sanitation and personal hygiene. CHS resources in the battalion are limited. Additional personnel must be trained in combat lifesaver skills to assist medical personnel in the initial treatment of casualties.

(b) Medical aidmen assigned to the HHC medical section accompany FARP personnel when they move forward; one medical aidman should be stationed at each FARP location. To augment the treatment capability far forward, one of the flight surgeons assigned to the aviation brigade can be attached to the battalion for the duration of the operation. The attachment of the physician completes the battalion treatment team.

(c) Provisions for a medical planner must be included in the planning process. The medical planner should consider the--

- Estimated casualty work load.
- Augmentation of medical personnel.
- Preplanned patient collecting points and ambulance exchange points.
- Augmentation of MEDEVAC resources by corps level evacuation assets.
- Use of nonmedical transportation assets for the movement of casualties to medical treatment facilities.
- Provision for medical personnel on nonmedical transportation assets to provide en route medical care.

b. Essential Personnel Functions. To sustain the battalion, the personnel/administration center must provide personnel services, financial services, and postal services. The PAC also provides or coordinates religious support, legal services, morale and welfare services, and public affairs support.

NOTE: Financial support for the battalion is coordinated by the S1 section through the area finance support unit.

(1) **Legal services.** These actions include processing UCMJ actions, drafting summaries of violations, and preparing DD Forms 458 (Charge Sheet). They also include processing Article 32 and 15-6 investigations, assembling investigation reports and witness statements, and preparing DA Forms 2627 (Record of Proceedings Under Article 15, UCMJ).

(2) **Chaplain activities.** Comprehensive religious support is provided by the UMT of the ATKHR or aviation brigade. The UMT consists of at least one chaplain and one chaplain assistant. Support provided by the UMT includes sacraments, rites, ordinances, and religious services. The UMT provides pastoral care in keeping with the overall mission to nurture the living, care for casualties, and to honor the dead. The UMT advises the command on moral, ethical, and religious issues affecting the unit's mission. Religious support is covered in FM 16-1.

(3) **Finance services.** The degree of financial services given the soldier varies with the tactical situation. In mid- and high-intensity conflicts, regularly established paydays are suspended in the theater of operations. When and where a unit is paid is determined by the unit commander and coordinated with unit finance personnel. The theater commander determines the maximum amount a soldier can be paid. Commanders at brigade or equivalent level (06 or above) may establish an amount that is less than the maximum amount that personnel in their unit who are engaged in a tactical situation would normally receive. FM 14-7 contains more details on finance operations.

(4) **Morale, welfare, and recreation support.** These activities include determining the needs and interests of the soldier, obtaining support from agencies, such as the division band, and obtaining recreation-related supplies. They also include providing equal opportunity counseling and drug and alcohol control.

(5) **Public affairs.** These activities include disseminating information and published material received from higher headquarters and implementing a hometown news release program. The hometown news release program will include preparing, reviewing, and submitting news releases through the local public affairs office.

(6) **Postal services.** The corps DS postal unit provides postal services for the ATKHB assigned to the corps ATKHR. Postal services for the ATKHB assigned to the divisional combat aviation brigade are provided by the corps DS postal unit through the division and brigade. In the early stages of a conflict, postal services for soldiers will usually be restricted to personal mail and limited post card and stamp sales. Personal mail must conform to the weight limitations prescribed by the "free mailing privilege." Normally, postal money orders will not be available in either contingency or prolonged operations.

(7) **Administrative services.** These support actions include initiating evaluation reports, SIDPERS transactions, awards and decorations, and promotions or reductions.

5-8. FIELD SERVICES

Field services are supported by specialty units within the division or corps support base. At the ATKHB level, field services are coordinated through the aviation brigade to the appropriate support agency or unit. FM 1-111 discusses field services and their availability in depth.

CHAPTER 6

STABILITY AND SUPPORT OPERATIONS

6-1. OPERATIONAL CONCEPT

a. In today's fluid political environment, the army has classified its activities in peacetime and conflict that do not necessarily involve armed clashes between two organized forces as SASO. SASO activities are outlined in FMs 100-5, 71-100, 1-100, 1-111, and 100-20.

b. The ATKHB may deploy as part of the aviation brigade or as the aviation element of another higher headquarters. These higher headquarters may include another brigade/division/corps headquarters, an Army force headquarters, or a JTF headquarters.

c. In SASO the majority of missions are focused on the efforts of CS and CSS units. Because of the attention these type of missions receive during SASO, CS and CSS units will frequently be the main effort, while combat units become the supporting effort.

6-2. PRINCIPLES OF SASO

a. Army doctrine is based on the principles of war. SASO also have principles that guide commander's actions. The seven principles of SASO are primacy of the political instrument, unity of effort, adaptability, legitimacy, patience and perseverance, restraint, and security.

b. The application of each principle will vary depending on the specific operations. Commanders must understand these principles, as they may be designated as TF commanders in an SASO. These principles are explained in depth in FM 100-5.

6-3. EMPLOYMENT GUIDELINES

a. Several key employment guidelines are provided in FM 1-111 for the aviation commander to consider in the planning process. The current attack helicopter doctrinal roles and missions as outlined in this manual also apply in an SASO environment. The attack helicopter unit commander will have to tailor his mission and assets as the situation requires.

b. The unit should expect a wide variety of missions and fluctuation of operations and plan accordingly. A staff must be able to adjust rapidly to many different operational considerations. The unit must plan ahead and have developed contingency plans for missions not normally addressed in the unit's METL. These missions can be identified and trained for at home station with situational training exercises.

FM 1-112

c. The operational conditions of SASO frequently require the integration of specialty personnel with the aviation unit staff, including civil affairs, psychological operations, SJA, and special forces personnel. Besides the specialty staff personnel, the units may be required to operate with infantry, armor, artillery, engineer or a combination of these assets. Whatever the composition, the unit must have a fully integrated staff that can coordinate and plan operations. Liaison officers from the ATKHB to other units and from supporting units to the ATKHB will be critical.

d. The civil and military laws, airspace restrictions, RF usage, ground convoy clearances, aircraft operating time restrictions, flight clearances, refueling procedures, and product disposal procedures vary in almost every country in the world. The aviation unit commander must be prepared to adapt his unit to the host nation operating environment. Serious complications can develop when host nation requirements are not met by the force, possibly resulting in restrictions on the unit or even mission failure.

e. The aviation unit commander must clearly understand the ROE and be prepared for them to change at any time during an operation. All ground and aircrew personnel should be briefed on the ROE prior to every mission. For ROE assistance, the unit commander should consult with the SJA representative. The aviation unit commander should plan for an SJA representative to deploy with the force.

6-4. TYPES OF OPERATIONS

There are seven types of operations that have some potential to result in armed conflict, therefore, involving attack helicopter operations.

a. **Show of Force.** A show of force is a mission carried out to demonstrate U.S. resolve in which U.S. forces deploy to diffuse a volatile situation that may be detrimental to U.S. interests. The deployment may take the form of combined training exercises, rehearsals, forward deployments of military forces, or introduction and buildup of military forces in a region. Attack helicopter mobility, flexibility, agility, and firepower makes them ideal for employment in such operations.

b. **NEOs.** NEO relocates threatened civilian noncombatants from locations in a foreign country or host nation. NEO may be conducted in a peaceful, orderly fashion or may require forcible means. Aviation may be used for the rapid movement of noncombatants. Scout and attack aircraft will provide security for the air movement and prepare to engage hostile elements that may attempt to interfere.

c. **Counter-Drug Operations.** Military efforts toward counter-drug operations support and complement, rather than replace, the efforts of other U.S. agencies. Attack helicopters may be used to support interdiction efforts by monitoring and detecting drug movements, locating production facilities, and reconnaissance of suspected drug production areas at night under FLIR and night vision devices.

d. Support for Insurgencies and Counter-Insurgencies. U.S. forces may directly support a host nation's counter-insurgency operations. Initially, the support may be C² aircraft, eventually it could include air assault units and attack or cavalry units for reconnaissance and security. Aviation units can expect to be task-organized into a TF of selected assault, medium lift, attack, and cavalry company/troop size units, depending on the mission.

e. Combatting Terrorism. Counterterrorism includes the full range of offensive measures taken to deter, prevent, and respond to terrorism. Although primarily a SOF mission, attack helicopter firepower may be required to support these type operations.

f. Peace Enforcement. These operations are taken in support of diplomatic efforts to restore peace between hostile factions. Since peace enforcement implies the use of force or its threat to coerce hostile factions to cease hostilities, attack units assigned to support these efforts must be prepared to apply combat power to restore order, separate warring factions, and return civil order and discipline. Attack helicopter units can expect reconnaissance and surveillance missions and security missions to protect the U.S. and allied forces involved, in addition to tightly controlled applications of force.

g. Attacks and Raids. The Army conducts attacks and raids to create situations that permit seizing and maintaining political and military initiative. Attacks by conventional air, ground, and aviation forces independently or in conjunction with SOF are used to destroy high value targets or demonstrate U.S. capability or resolve. Aviation forces will conduct these attacks and raids with attack or assault helicopter units, or both, often with air cavalry reconnaissance and security elements.

6-5 LESSONS LEARNED

This paragraph was developed from information and after action reviews from the CMTC and the Operation Joint Endeavor Initial Impressions Report published by the Center for Army Lessons Learned. It provides some useful TTP for attack helicopter units conducting SASO. However, as FM 100-20 states:

"No two situations leading to stability and support operations are alike. Each must be studied and understood for what it is. A course of action must be designed to fit the peculiarities of the situation." **FM 100-20** (final draft, dated April 1996)

a. Sample Aviation TF Mission Statement.

Aviation TF deploys to the former Republic of Danubia NLT (DTG) conducts ZOS reconnaissance, security, quick response force, utility, and attack operations in support of United Nations Resolution ###'s peace keeping operations.

Planner's mission analysis of the above statement yields the following critical tasks: first priority ZOS reconnaissance, 24- hour operations (QRF), air and ground security, the

FM 1-112

entire range of utility operations, liaison with ground forces, and plans for transition to conventional attack operations. Although attack helicopters will not participate in all of the above missions, they will participate in most because of the inherent security requirements of the unknown and volatile environment.

b. Specific Lessons. The following points may assist planners and commanders as they develop, wargame, analyze, and determine their COA, policies, and procedures.

(1) Video reconnaissance. The onboard video recording systems on the AH-64 and OH-58D can provide extremely useful intelligence information if properly used. Planners must develop NAIs and procedures that focus aircrews where to look and record and aircrews must be as proficient at operating the VRS as they are with their weapons systems or hours of useless videotape may result.

(2) Debriefing. Commanders must develop a deliberate debriefing method that includes necessary staff members. Additionally, the incompatibility of the AH-64's VRS with standard VRS formats makes this a challenging, but not insurmountable, task.

(3) Situational awareness. Commanders must develop methods to keep their aircrews constantly aware of the multitude of changes and the possibility of rapid escalation of hostilities common to SASO. Ground TF Liaison Officers are excellent sources of current information concerning the disposition and activities of friendly forces and others.

(4) Spot reports. The standard SALUTE format is a good starting point, but may require adaptation to pass required information to decision makers in times of escalating tensions or imminent hostilities. Planners should make available to aircrews specific guidance for these situations, but aircrews must, as always, "think on their feet" from the cockpit. The following quote from FM 100-20 illustrates this point.

"In SASO, junior officers and noncommissioned officers often operate at remote locations and have to make decisions with far-reaching consequences without the opportunity to consult their superiors." **FM 100-20** (final draft, dated April 1996)

(5) Impact of armed helicopters. The capabilities of our armed aircraft provide commanders a unique ability to impact upon potentially belligerent forces. The sudden presence of enormous firepower can have a lasting impact and be extremely persuasive. This power of persuasion, however, carries with it a great responsibility to avoid provoking hostilities.

(6) GRM. A GRM supplements the ROE by providing specific instructions for actions in the objective area to aircrews and AMC. A GRM prescribes certain actions and protection measures based upon the overall situation or situation change. The GRM is designed to enhance, not replace, the good judgement of crew members, and enable them to make sound decisions in the heat of the SASO battle. Figure 6-1 depicts a sample GRM that was developed by the Falcon team at CMTC.



MOUNTAIN EAGLE III GRADUATED RESPONSE MATRIX



| SITUATION | MISSION | ACTIONS IN OBJECTIVE AREA |
|---|--------------------------------------|--|
| <ul style="list-style-type: none"> FWF COMPLIANCE NO HOSTILE ACTIVITIES AGAINST IFOR OR PROTECTED PERSONNEL | <p>PRESENCE (RECONNAISSANCE)</p> | <ul style="list-style-type: none"> DISTANT OBSERVATIONS, SPOT REPORTS, AND DATA RECORDER ALTITUDES AS DIRECTED 300' DAY, 500' NIGHT WEAPON SYSTEMS COLD |
| <ul style="list-style-type: none"> FWF NONCOMPLIANCE THREATENING BUT NO HOSTILE ACTIONS AGAINST IFOR OR PROTECTED PERSONNEL | <p>SHOW OF FORCE (SECURITY)</p> | <ul style="list-style-type: none"> VISIBLE AT STAND OFF RANGE PRESS THE TARGET, DEPLOY TO COVER IF REQUIRED DOCUMENTATION AND REPORTING ALL ACTIONS VIA RECORDER WEAPONS STATUS STAND-BY |
| <ul style="list-style-type: none"> FWF NONCOMPLIANCE HOSTILE ACTIONS AGAINST IFOR OR PROTECTED PERSONNEL | <p>LETHAL RESPONSE (ATTACK)</p> | <ul style="list-style-type: none"> ESTABLISH BATTLE POSITIONS, MAINTAIN STAND OFF USING COVER MAINTAIN CONTACT WITH HOSTILE FORCES REPORT CLEAR FIRES APPLY ROE OR REQUEST WEAPONS RELEASE WEAPONS SYSTEM HOT |

TRAIN TO WIN
Combat Maneuver Training Center

Figure 6-1. Example of a GRM

APPENDIX A

ATTACK AIRCRAFT CHARACTERISTICS

A-1. AH-64A

This paragraph discusses aircraft characteristics, capabilities, and limitations of the AH-64A Apache (see Figure A-1).

a. Description.

(1) The AH-64A is a twin-engine, tandem-seat, four-blade attack helicopter. With its crew of two rated aviators, the pilot occupies the rear station and a copilot/gunner occupies the front station.

(2) The aircraft is approximately 57 feet long with a 48-foot main rotor span.

(3) Maximum gross weight 21,000 pounds.

(4) Maximum airspeed (level) is 164 knots; normal cruise speed is 100 - 120 knots.

b. Capabilities. The AH-64 provides commanders the following advanced capabilities:

(1) The AH-64 has day, night, and limited adverse weather fighting capabilities.

(2) It has improved combat survivability.

(3) It has twin engine performance and reliability.

(4) It has a wide array of firepower options.

(5) It also has advanced crashworthy design features.

(6) The AH-64 can be configured with an external 230-gallon fuel tank to extend its range on attack missions, or it can be configured with up to four 230-gallon fuel tanks for ferrying/self-deployment missions.

(a) The combat radius of the AH-64 is approximately 150 kilometers.

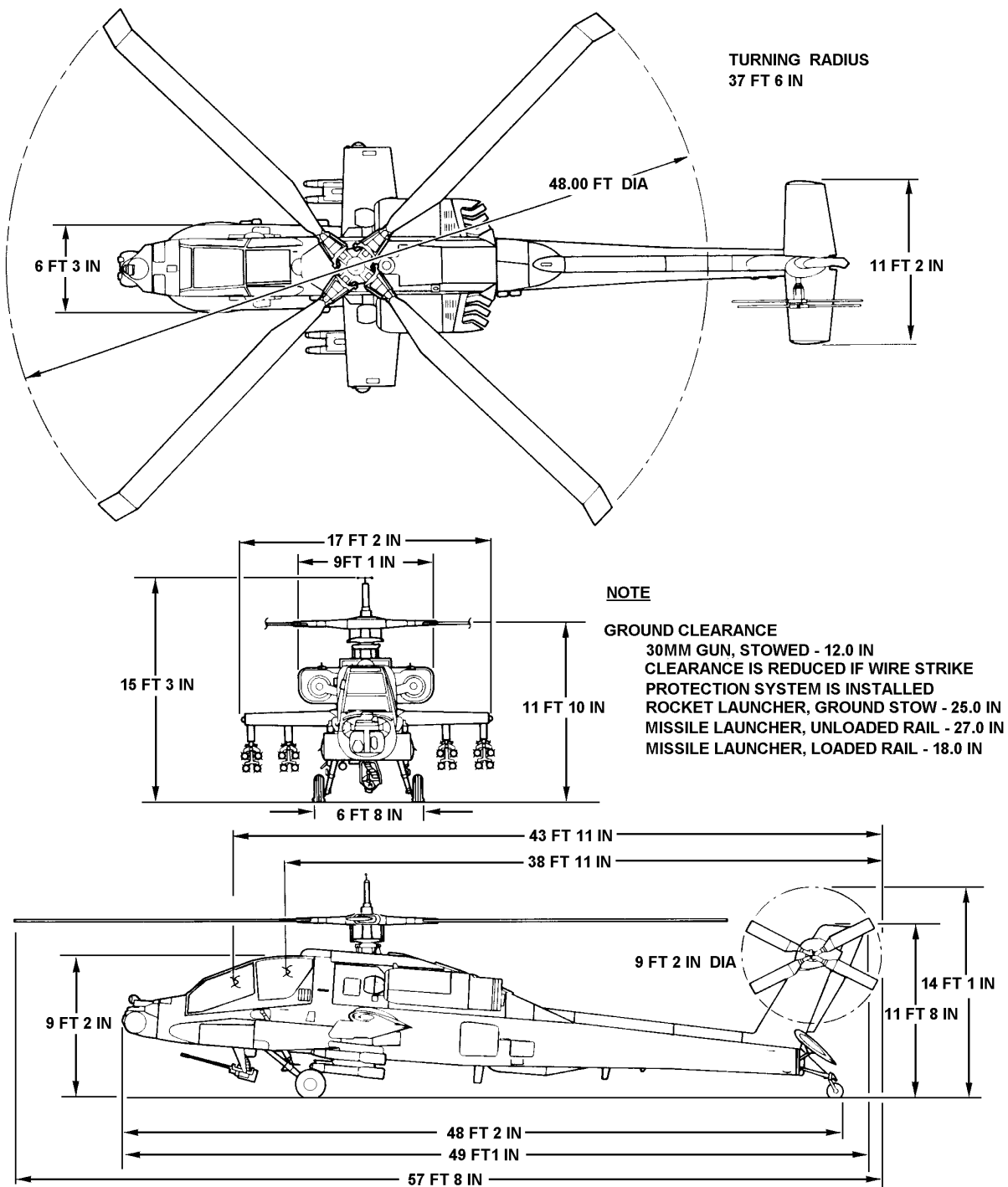

Figure A-1. General dimensions, AH-64A

(b) The combat radius with one external 230-gallon fuel tank installed is approximately 300 kilometers.

NOTE: Both radii are temperature, PA, fuel burn rate and airspeed dependent.

(7) The AH-64 is air transportable in the C-5, C-141 and C-17.

(8) An on-board video recorder has the capability of recording up to 72 minutes of either the pilot or CPG selected video. It is an invaluable tool for damage assessment and reconnaissance.

(9) The Apache's navigation equipment consists of a doppler navigation system, and most aircraft are equipped with a GPS receiver.

(10) The Apache has state of the art optics that provide the capability to select from three different target acquisition sensors. These sensors are--

- Day TV. Views images during day and low light levels, black and white.
- TADS FLIR. Views thermal images, real world and magnified, during day, night and adverse weather.
- DVO. Views real world, full color, and magnified images during daylight and dusk conditions.

c. **Apache Armament Systems.** The Apache has four articulating weapons pylons, two on either side of the aircraft, on which weapons or external fuel tanks can be mounted. The aircraft has a LRF/D. This is used to designate for the Hellfire missile system as well as provide range to target information for the fire control computer's calculations of ballistic solutions.

(1) **M230A1 "Chaingun" 30mm cannon.**

- Used primarily against soft-skinned and lightly armored targets, and for self protection.
- Single barrel, externally powered, hydraulically driven turret.
- Maximum capacity: 1200 rounds; rate of fire: 600 - 650 rounds/minute.
- Maximum range: 4,000 meters; maximum effective range: 1500 - 1700 meters.
- Ordnance: M789 HE, dual purpose ammunition.

(2) FFAR system, 70mm.

- Maximum range: 9,000 meters; most effective range: 3,000 - 4,000 meters.
- Ordnance: HE, HE MPSM, white phosphorus, illumination, and flechette.
- Maximum load: 76 rockets.

(3) Hellfire missile system.

(a) The Hellfire is a laser guided missile capable of defeating any known armor.

(b) There are two types of engagements. The first type of engagement is autonomous. The aircraft that fires the missile also provides the laser energy for the missile. The second type of engagement is remote. The missile is fired from one aircraft, but the required laser designation is provided by another AH-64, a ground laser designator, or an OH-58D (I).

(c) The minimum range is 500 meters. The maximum range is 8,000 meters. The maximum load is 16 missiles.

(4) Armament configuration. The Apache's battlefield performance allows it to fully support several different mission profiles with a wide armament array. Table A-1 shows the various armament configurations available.

Table A-1. AH-64 mission profiles

| MISSION | HELLFIRE | 30MM | FFAR | SPEED | RATE OF CLIMB(F/M) | ENDURANCE (HRS) |
|----------------|----------|------|------|-------|--------------------|-----------------|
| ANTI-ARMOR | 16 | 1200 | | 148 | 990 | 2.5 |
| COVERING FORCE | 8 | 1200 | 38 | 150 | 860 | 2.5 |
| ESCORT | | 1200 | 76 | 153 | 800 | 2.5 |

(5) Standard weapons configurations. Commanders can use the standard weapons configurations listed in Table A-2 or modify them as desired:

Table A-2. AH-64 Mission configurations

| LOAD | L/O PYLON | L/I PYLON | R/I PYLON | R/O PYLON | ROLE |
|---|------------|------------------|------------------|------------|---------|
| A | 4 Hellfire | 19 Rockets | 19 Rockets | 4 Hellfire | Sct/Atk |
| B | 4 Hellfire | 230 gal ext tank | 19 Rockets | 4 Hellfire | Sct/Atk |
| C | 4 Hellfire | 4 Hellfire | 4 Hellfire | 4 Hellfire | Attack |
| D | 4 Hellfire | 4 Hellfire | 230 gal ext tank | 4 Hellfire | Attack |
| E | 19 Rockets | 19 Rockets | 19 Rockets | 19 Rockets | Sct/Atk |
| F | 19 Rockets | 230 gal ext tank | 19 Rockets | 19 Rockets | Sct/Atk |
| G | 4 Hellfire | 19 Rockets | 230 gal ext tank | 19 Rockets | Scout |
| NOTE: All loads include 1200 rounds 30mm ammunition | | | | | |

d. Apache limitations.

(1) **Threat identification.** Threat identification through the FLIR system is extremely difficult. Although the AH-64 crew can easily find the heat signature of a vehicle, it may not be able to determine friend or foe.

(2) **Infrared crossover.** Forward looking infrared detects the difference in the emission of heat in objects. On a hot day, the ground may reflect or emit more heat than the suspected target. In this case, the environment will be "hot" and the target will be "cool". As the air cools at night, the target may lose or emit heat at a lower rate than the surrounding environment. At some point the emission of heat from both the target and the surrounding environment may be equal. This is IR crossover and makes target acquisition/detection difficult to impossible. IR crossover occurs most often when the environment is wet. This is because the water in the air creates a buffer in the emissivity of objects. This limitation is present in all systems that use FLIR for target acquisition.

(3) **Low cloud ceilings.** Low cloud ceilings may not allow the Hellfire seeker enough time to lock onto its target or may cause it to break lock after acquisition. At extended ranges, the pilot may have to consider the ceiling to allow time for the seeker to steer the weapon onto the target.

(4) **Overwater Operations.** Overwater operations severely degrade navigation systems not upgraded with embedded GPS.

(5) **PNVS.** Pilot night vision sensor cannot detect wires or other small obstacles.

(6) **Obscurants.** Some obscurants can prevent the laser energy from reaching the target; they can also hide the target from the incoming munitions seeker. Dust, haze, rain, snow and other particulate matter may limit visibility and affect sensors.

(7) **Hellfire remote designation constraints.** The designating crew may offset a maximum of 60 degrees from the gun to target line and must not position their aircraft within a ± 30 -degree safety fan from the firing aircraft (see Figure A-2).

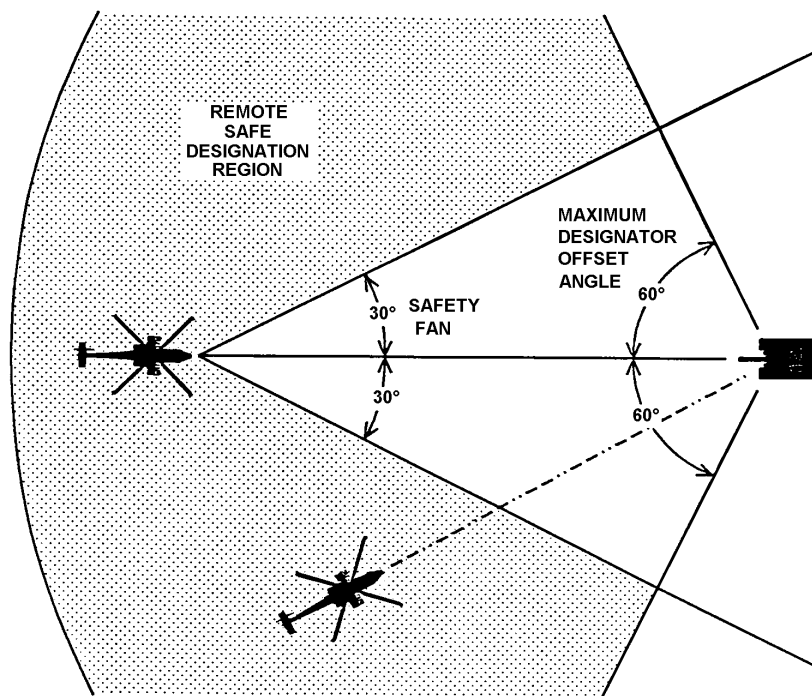
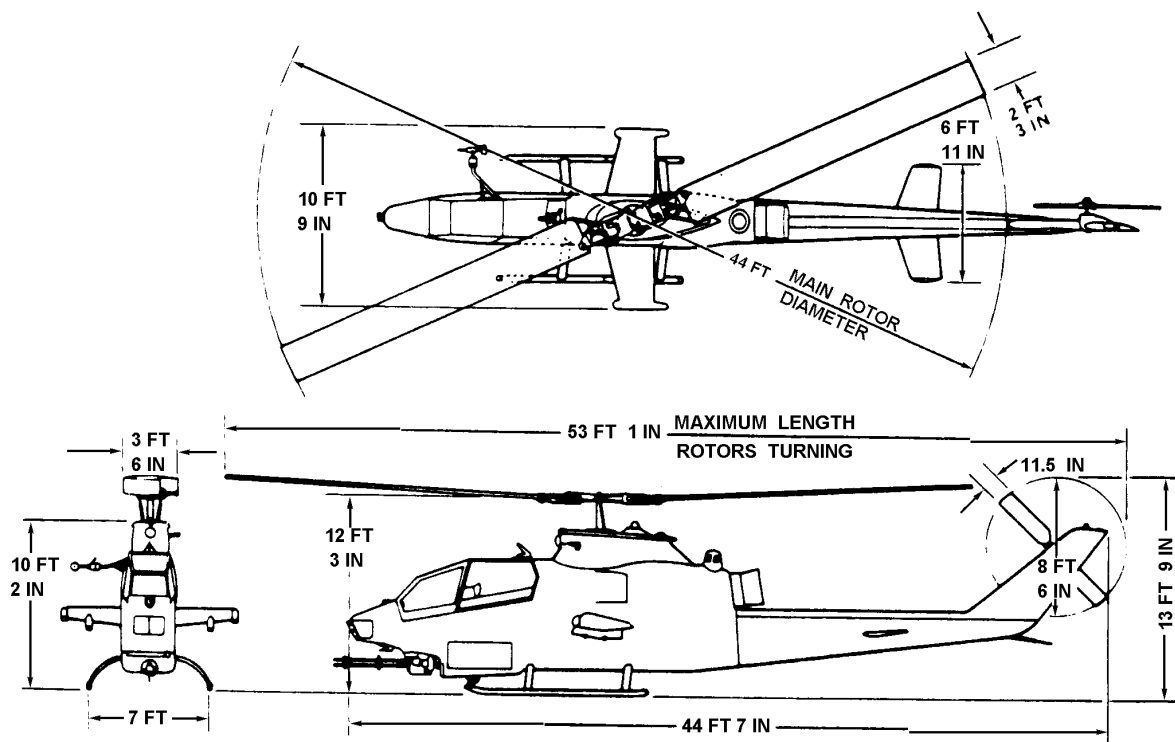

Figure A-2. AH-64 Hellfire remote designation

A-2. AH-1

This paragraph discusses aircraft characteristics, capabilities and limitations for the AH-1 Cobra (see Figure A-3).



NOTE

DIMENSIONS ARE FOR UNDEFLECTED
SKID GEAR.

Figure A-3. General dimensions, AH-1F Cobra

a. Description.

(1) The AH-1 Cobra is a single-engine, tandem-seat, two-blade attack helicopter. With its crew of two rated aviators, the pilot occupies the rear station and the copilot/ gunner occupies the front station.

(2) The Cobra is essentially a daytime weapons platform due to the inability to fire and track the TOW missile at night. Some Cobras have been modified with a terminal night sight called C-NITE. This system allows the gunner to thermally track the TOW missile at night through the TSU.

(3) The maximum airspeed is 120 - 140 knots. Normal cruise speed is 100 knots.

(4) The maximum gross weight is 10,000 pounds.

b. Capabilities.

- (1) AH-1 combat radius is approximately 100 km.
- (2) The AH-1 is equipped with a doppler navigation system.
- (3) It is air transportable in the Air Force C-5, C-141 and C-17.

c. AH-1 Armament Systems. The AH-1 Cobra is equipped with TOW missile launchers on wingtip articulating pylons, a chin-mounted uncowed turret, a laser range finder, heads-up display, and a fire control computer. Either 7 or 19 shot rocket pods are normally mounted on each of the inboard wing mounting points.

(1) M197 20mm cannon.

- Used primarily against soft-skinned and lightly armored targets and for self-protection.
- Three-barreled, externally powered, hydraulically driven turret.
- Maximum capacity: 750 rounds; rate of fire: 730 rounds/minute.
- Maximum range: 2,000 meters; maximum effective range: 1,500-1,700 meters.
- Ordnance: M789 HE, dual purpose ammunition.

(2) FFAR system, 70mm.

- Maximum range: 9,000 meters; most effective range: 3,000 - 4,000 meters.
- Ordnance: HE, HE MPSM, white phosphorus, illumination, and flechette.
- Maximum load: 76 rockets. The rockets can be loaded into either a 7-shot (M260) or a 19-shot (M261) rocket launcher that can be mounted on each wing store in the inboard or outboard position.

(3) TOW missile system. The TOW missile is an antiarmor precision guided weapon, which is tube launched, optically tracked and wire guided. Maximum range is 3,750 meters. An AH-1 can carry a maximum of 8 TOW missiles.

d. Limitations.

(1) The AH-1 is limited to 10,000 pounds gross weight. Most airframes weigh over 9,000 pounds with crew and a full load of fuel. Cobra crews will always have to figure the ammunition needed for the mission and trade fuel weight for ammunition

weight as needed to complete the mission (Table A-3). In doing this the crew will also be reducing airframe station time.

Table A-3. Basic loads and weapons configurations

| MISSION | ROCKETS | 20mm | TOW | FUEL |
|--|----------|------|-----|-------|
| Antiarmor | 14(MPSM) | 300 | 4 | 1,200 |
| Antipersonnel | 38(MPSM) | 100 | 0 | 900 |
| NOTE: The above planning profiles will vary based on the operating environment, ammunition, and the gross weight of the aircraft. Both examples will take the airframe to 10,000 pounds. | | | | |

(2) Operations in areas with high PA or high temperatures will greatly reduce the effectiveness of the aircraft due to the low gross weight to power ratio of the airframe. The effectiveness of the weapons systems is greatly reduced during night operations.

A-3. OH-58D (I) KIOWA WARRIOR

This paragraph discusses characteristics, capabilities and limitations for the OH-58D (I) Kiowa Warrior (see Figure A-4).

a. Description.

(1) The OH-58D Kiowa Warrior is a single-engine, dual-seated, four-blade armed observation helicopter. With its crew of two, the pilot occupies the right seat and the copilot occupies the left seat.

(2) The maximum gross weight is 5,500 pounds.

(3) The maximum airspeed is 125 knots. Normal cruise speed is 100 knots.

b. Capabilities.

(1) The OH-58D is air transportable in the Air Force C-130, C-141, C-5 and the C-17.

(2) It is equipped with advanced navigation and mission planning equipment.

(3) The combat radius is approximately 120 kilometers.

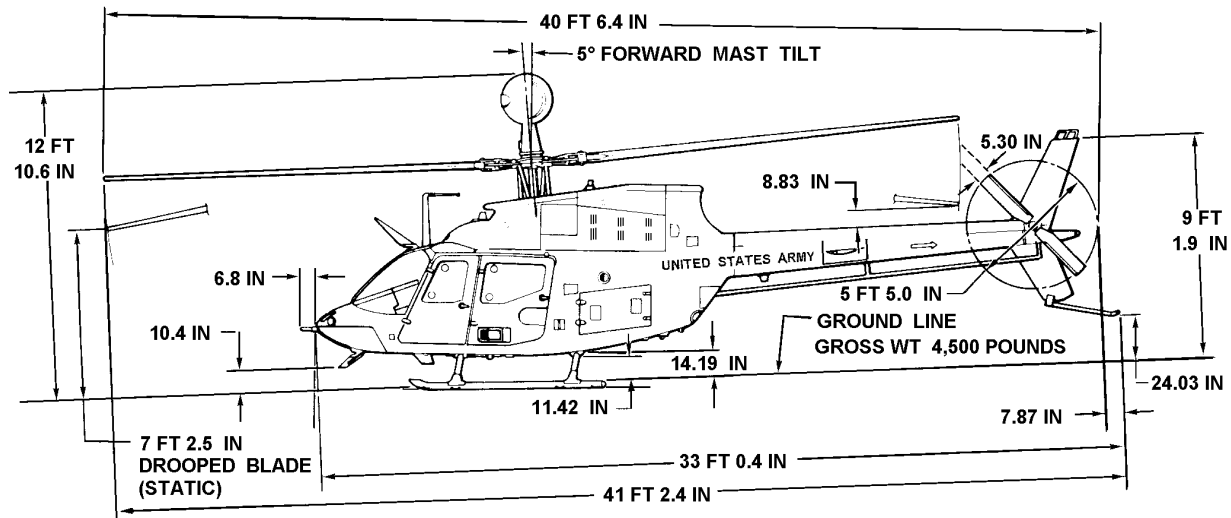

Figure A-4. General dimensions, OH-58D (I)

c. **Armament Systems.** The Kiowa Warrior has two universal weapons pylons, one located on either side of the aircraft, on which several weapons can be mounted. The aircraft has a LRF/D. This is used to designate for the weapons system as well as provide range to target information for the ATHS and on-board weapons systems (see Figures A-5 and A-6).

(1) **Machine gun, .50 caliber.** This machine gun is an air cooled, belt fed, electronically controlled weapon that can be mounted on the left weapons pylon. The weapon holds 500 rounds with a duty cycle of 150 rounds with a one-minute cooling period. The weapon fires either in the continuous mode or the burst can be limited to one-second burst of 12 to 14 rounds. The .50 caliber has a maximum range of 2,000 meters and a maximum effective range of approximately 1,000 meters.

(2) **FFAR system, 70mm.**

(a) The maximum range is 9,000 meters. The most effective range is 3,000 - 4,000 meters.

(b) The ordnance consists of HE, HE MPSM, white phosphorus, illumination, and flechette.

(c) The maximum load is 14 rockets. The OH-58D can carry two, 7-shot M260 rocket pods.

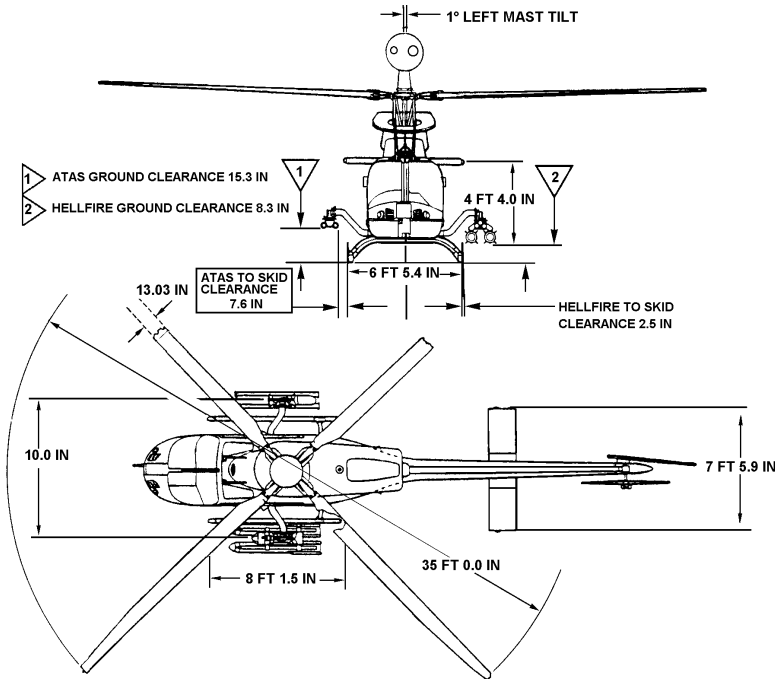

Figure A-5. Dimensions, missile configuration and rotor system, OH-58D (I)

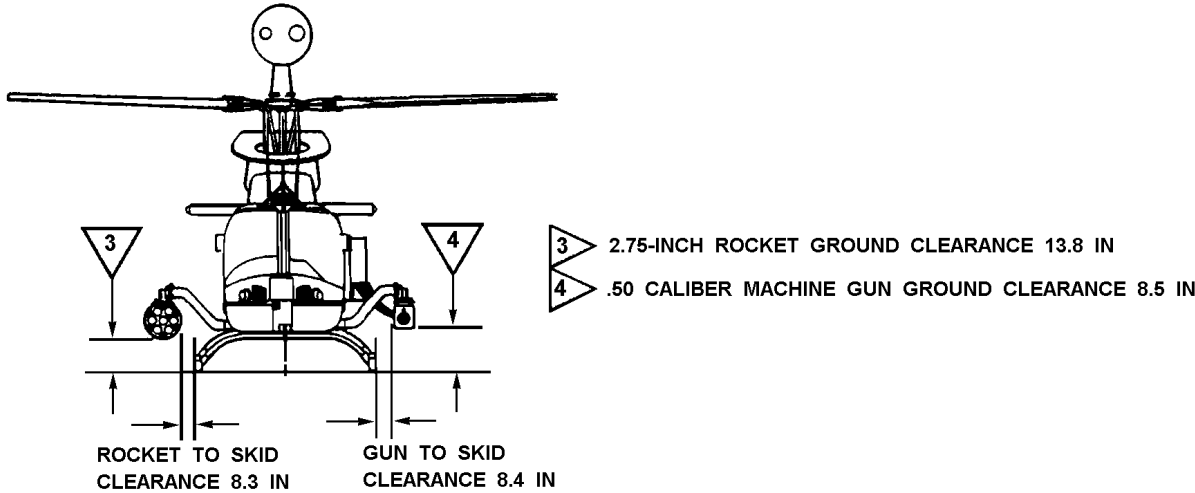

Figure A-6. Dimensions, OH-58D (I) scout configuration

(3) **Hellfire missile system.**

(a) The Hellfire is a laser-guided missile capable of defeating any known armor.

(b) There are two types of engagements. The first type of engagement is autonomous. The aircraft that fires the missile also provides the laser energy for the missile. The second type of engagement is remote. The missile is fired from one aircraft, but the required laser designation is provided by another OH-58D (I), a ground laser designator, or an AH-64.

(c) The minimum range is 500 meters. The maximum range is 8,000 meters. The maximum load is 4 missiles.

(4) **ATAS.** The ATAS is an ATA heat seeking missile with fire and forget capability. The OH-58D can carry 2 ATAS per pylon. The ATAS has a minimum range of less than 1,000 meters and a maximum engagement range of more than 4,000 meters.

d. **Limitations.**

(1) **Infrared crossover.** The TIS operates on determining temperature differentials. There are times when the temperature of objects and their surroundings reach the same temperature, and target detection is degraded.

(2) **Obscurants.** Dust, rain, haze, and smoke can reflect the laser energy so it would prevent it from reaching the target. Fog and haze will also effect the duration and the effect of IR crossover.

(3) **Low clouds/ceilings.** Low ceilings may not allow the HELLFIRE seeker enough time to lock onto its target, or the missile may break lock after acquisition.

(4) **IMC.** The aircraft is not certified for IMC flight. It does not have any navigation receivers on board.

(5) **Hellfire remote designation constraints.** The designating crew may offset a maximum of 60 degrees from the gun to target line and must not position their aircraft within a ± 30 -degree safety fan from the firing aircraft (see Figure A-7).

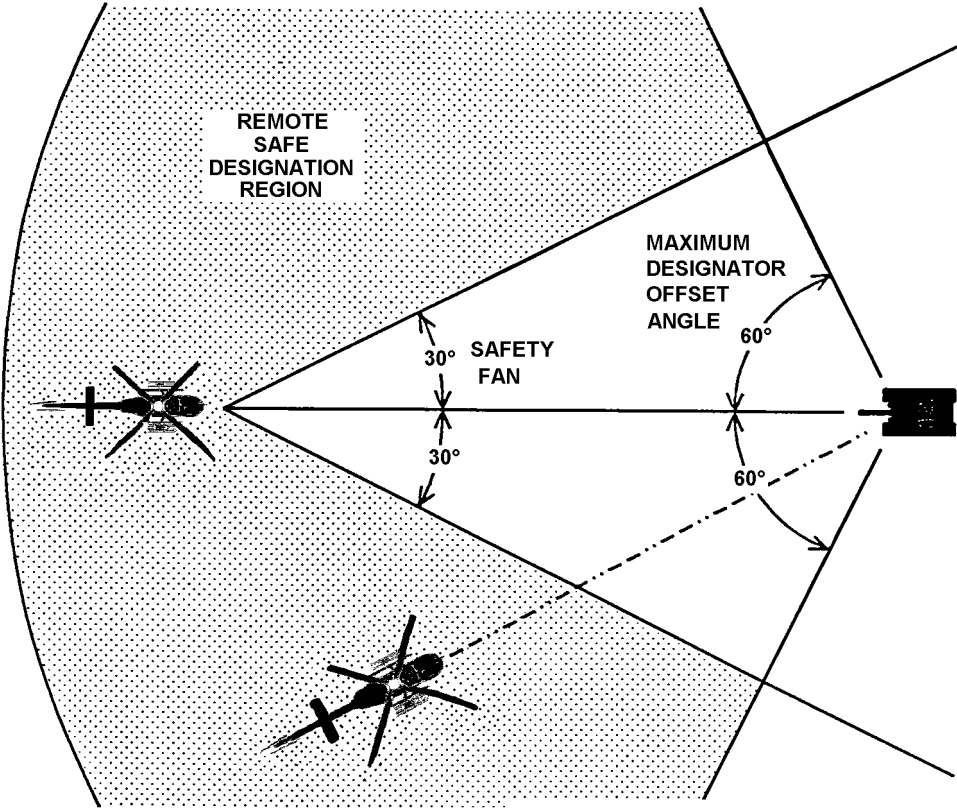

Figure A-7. OH-58D (I) Hellfire remote designation

APPENDIX B

AIR ASSAULT SECURITY

B-1. INTRODUCTION TO AIR ASSAULT

a. As defined in FM 101-5-1, air assault operations are "operations in which air assault forces (combat, combat support [CS], and combat service support [CSS]), using the firepower, mobility, and total integration of helicopter assets in their ground or air roles, maneuver on the battlefield under the control of the ground or air maneuver commander to engage and destroy enemy forces or to seize and hold key terrain."

b. Air assault operations are inherently complex, fully synchronized combat operations. They are a form of maneuver particularly important for light forces as they are the primary means of rapid deployment. In some cases, they are the only means of employment directly into combat. Air assault operations are occasionally used by heavy forces to assist in overcoming obstacles in the seizure of critical terrain.

c. The level of precision required to successfully conduct air assault operations requires deliberate planning and the detailed synchronization of all BOS. Air assault security is provided by air cavalry and attack units in coordination with conventional FS to set conditions prior to the air assault and to continue to provide supporting fires once the air assault force is established on the ground.

B-2. AIR ASSAULT SECURITY

a. Air assault security operations provide force protection for air assault operations. Air assault security encompasses the entire range of planning and operations conducted to protect the air assault TF as it moves from PZs to LZs, accomplishes its ground tactical mission, and returns. It is planned and executed as an integral part of the air assault operation and is planned at the air assault TF level.

(1) Like most other operations involving aviation assets, air assault security requires centralized planning and decentralized execution. In its most complex form, air assault security is a highly synchronized operation often involving many different types of units executing reconnaissance, security, EW, SEAD, FS, and other missions in support of the air assault TF. The complexity of air assault security operations will often be greatest for deep operations and lower for close and rear operations. Generally, once a route is secured, it will remain secure for some time. This allows a security force (based on METT-T) to precede the assault force along a route.

(2) Historically, most air assault operations conducted during low intensity conflicts have faced a light infantry threat. However, during mid- to high-intensity conflicts, the AATF can expect its greatest threat to be enemy artillery. In both cases,

attack helicopters can provide accurate, responsive fires for the AATF. This is particularly important during operations when the AATF is outside of friendly artillery range.

b. Units Participating in Air Assault Security.

(1) Cavalry/reconnaissance units. Reconnaissance and security are vital components of air assault security operations. Air cavalry/reconnaissance units play major roles in these operations. Missions for these units include screening and reconnoitering air axes or routes, PZs and LZs, providing suppressive fires, and conducting passage of lines. METT-T determines how these units are actually employed. When attack helicopter units are not available, air cavalry/reconnaissance units may be required to perform attack missions within the limits of their capability. Ground cavalry formations may also be employed in the security role. Probable missions for ground cavalry include PZ security, reconnaissance of routes, and LZs.

(2) Attack helicopter units. Attack helicopter battalions or companies are capable of performing the missions of air cavalry/reconnaissance units, and conduct these missions when air cavalry units are not available. The attack helicopter units also conduct overwatch and screening of the air assault force during movement along the air axes from PZ to LZ, providing protection against enemy ground fire or attacks by armed helicopters. They provide suppressive fires, SEAD, and may be used as a reserve force to counterattack threats to the AATF. Attack helicopters may also be integrated into the scheme of maneuver for the ground tactical phase, where they may be used to conduct screen or guard missions, hasty attacks, or other doctrinal missions in support of the AATF.

(3) MI units.

(a) Corps and division MI units equipped with short range unmanned aerial vehicles can provide reconnaissance and surveillance for air assault operations. Divisional and corps LRSD teams and pathfinder units can provide similar intelligence products. UAVs equipped with day television or FLIR sensor packages are capable of reconnoitering air routes, LZs, and objectives before and during air assault operations.

(b) UAVs operating at medium altitude provide battlefield information that may be used in planning and conducting air assault security operations. Information may include suitability of air axes, obstacles, enemy force dispositions, and other pertinent information. During air assault security operations, UAVs precede cavalry, attack, or transport helicopter units of the air assault force, and provide early warning to allow the air assault TF to defeat or bypass enemy forces. UAVs may then be employed to maintain surveillance of the LZs, objective, enemy avenues of approach into the objective area, alternate and return flight axes, or other critical locations.

(c) LRSD/pathfinder teams can provide the same information, but are susceptible to interception or interdiction and are not nearly as mobile. On the plus side, the LRSD/Pathfinder teams allow flexibility and the ability to inject human judgement

into the intelligence products. MI units also have the capacity to provide EW support to air assault security operations.

(4) FS systems. Lethal and nonlethal FS systems are often integral participants in the air assault security effort. FS systems are used to destroy, neutralize, deceive, or suppress enemy forces that pose a threat to the AATF. These systems are employed according to the commander's intent for fires.

(a) Lethal FS systems. Systems available for air assault security may include mortars, FA (cannon, missiles, rockets), NGF, and CAS. In cases where FS systems are limited by range or availability, attack helicopters may also be employed to maneuver against enemy targets in support of the AATF. Specific missions include engaging enemy ground forces, indirect FS systems, and AD systems to prevent or disrupt attacks on the AATF.

(b) Nonlethal FS systems. These FS means include EW systems and smoke delivered by mortars, NGF, or FA systems. EW is employed to disrupt enemy C³, degrade enemy FS and AD radio nets, and inhibit other enemy intelligence systems. Smoke is used to screen movement of the AATF or obscure enemy direct fire weapon systems.

B-3. AIR ASSAULT SECURITY PLANNING

a. General.

(1) Planning for air assault security is based on METT-T. Corps or division assets are often involved in planning and executing air assault security for deep operations. Air assault security is planned early and continuously as an integral part of the air assault mission reverse planning process. Though some units tasked with air assault security may be company/troop size, planning for their employment should be executed no lower than battalion/squadron level. Actions taken during the planning process enhance security and reduce the chances of disruption or defeat of the air assault TF during mission execution.

(2) Air assault security will vary based on the mission of the AATF. During mission planning, the AATFC and AMC determine the likelihood of enemy contact and capabilities of enemy forces to threaten the AATF during each phase of the air assault operation. The composition, size, and employment of the air assault security force during deep operations for the air movement, landing, and ground tactical phases will be determined in part by this analysis. During operations on a nonlinear battlefield, contact could be possible during every phase. For close and rear operations, enemy contact might be expected only during the landing and ground tactical phases.

b. Planning Considerations for Air Assault Security.

FM 1-112

(1) **IPB.** IPB provides information that will identify actual or likely enemy dispositions and capabilities in the vicinity of LZs and along flight routes. Planners use this information to select flight routes that avoid the enemy and provide maximum cover and concealment to the air assault TF.

(2) **Reconnaissance.** Thorough air or ground reconnaissance of PZs, routes, key terrain, and LZs conducted prior to mission execution provides planners with valuable information. When OPSEC considerations preclude Army Aviation systems from overflying these areas in advance of the air assault operation, reconnaissance may be conducted with other systems including SEMA, UAVs, J-STARS, and other intelligence assets.

(3) **Terrain and environmental considerations.** Terrain can be used to enhance the security of air assault forces. Air routes should be planned to take advantage of masking terrain or cover. Aircraft performing high speed contour flight over forests or jungles minimize their exposure to ground fire, which reduces the need for security forces. Conversely, when operating over terrain that provides the enemy long range observation and fields of fire, air assault forces will normally require a larger security force. Night operations, though more complex, reduce the possibility of the air assault force being detected and engaged. Alternate flight routes allow air assault forces to avoid enemy units discovered during the execution of the air assault. Attack helicopters and FS assets can be planned to dominate key terrain and deny its use to enemy forces that might threaten the AATF.

(4) **Aviation units.** Although air assault security is normally performed by cavalry/reconnaissance or attack helicopter units, the assault helicopter unit commander is normally assigned the role of AMC. Aviation unit commanders and operations officers participate directly in air assault security planning at the earliest possible time. Cavalry/reconnaissance and attack helicopter units are task organized to provide air assault security. The type, number, weapons configuration and employment of these units vary with METT-T. Cargo and assault helicopter units plan for the use of door guns to engage enemy forces along air routes and LZs. All units should plan detailed actions on contact including procedures for reacting to ground fire, attack by armed helicopters or high performance aircraft, downed aircraft, and procedures for moving to alternate air routes, PZs and LZs.

(5) **Ground tactical plan.** All members of the air assault TF must know and understand the ground tactical plan. Additionally, all members of the TF must have the ground commander's control measures and scheme of maneuver on their maps. This will allow responsive support and reduce the possibility of fratricide in the objective area, especially at night.

(6) **FS.** Artillery and mortar fires, CAS, and NGF are planned to provide SEAD, obscuration, and suppressive fires along routes and in LZs. The element responsible for security of the AATF should control the fires until the ground force commander has sufficient combat power in the objective area to assume the battle. Once he does have that sufficient combat power in the objective area, the FS plan that is part of the ground

tactical plan is also important to consider. If there will be multiple lifts into an objective area, the ground tactical force may be able to provide fires for the later lifts. These fires are not always responsive enough to destroy immediate threats to air assault forces moving along flight routes, but may be used to suppress or obscure known or suspected enemy units before they can engage the AATF or following lifts/serials. These systems may also be used to deceive the enemy by firing preparations into false LZs and passage points (deceptive SEAD). Nonlethal FS that includes EW, smoke and deceptive fires, provide security by degrading observation, jamming enemy communications nets, FS nets, and AD radars, and deceiving the enemy as to the location of the objective areas. Just as all members of the AATF need to have the ground tactical plan scheme of maneuver on their maps, they must also have the scheme of fires and control measures to provide responsive support and prevent fratricide.

(7) **Control measures.** Maneuver and airspace control measures are planned in a manner that enhances security for the air assault force. Primary and alternate air axes or routes provide more freedom of maneuver, allowing the AATF to bypass enemy concentrations or attacks. Attack helicopter battle positions are planned to support PZs, LZs, and flight routes. ROZs are planned over PZs, LZs, and FARPS to protect the force from airspace conflicts. During deep operations, a coordinating altitude should be established forward of the FLOT if none exists. FS coordinating measures such as ACAs are planned to allow attack of targets by multiple FS assets while providing protected airspace for AATF aircraft.

(8) **CSAR/downed aircraft procedures.** Rescue of downed aircrews and personnel, and recovery of aircraft is planned as part of the air assault security effort. Pickup of downed aircrews and personnel is usually accomplished by an assault helicopter operating independently of the assault elements. During large operations conducted across the FLOT or on a nonlinear battlefield, the AATFC and AMC may decide to form a dedicated CSAR element. This element may consist of a MEDEVAC/CASEVAC aircraft, an assault helicopter with a small ground security force, and an attack helicopter element. The AMC plans for the employment of this force to extract personnel and secure and recover downed aircraft. This force also destroys downed aircraft when ordered by the approving authority.

(9) **Rehearsals.** The air assault security operation is rehearsed as an integral part of the AATF rehearsal. The AMC ensures that all subordinate commanders including cavalry, attack, assault, cargo, and CSAR attend the rehearsal. These commanders then return to their units and in turn conduct detailed rehearsals for each of their key leaders and aircrews.

B-4. RESPONSIBILITIES

a. **AATFC.** The AATFC ensures that air assault security is integrated into the planning and execution of the air assault operation. The AATFC and his staff plan and coordinate the use of all available assets to provide air assault security.

FM 1-112

b. AMC. The AMC formulates the air assault security plan based on the AATFC's guidance. He works closely with the AATF staff and aviation unit commanders to plan the employment of cavalry and attack units for air assault security operations from the PZ to LZ. As a minimum, the AMC should be assisted in planning by an aviation battalion-level staff. The AATF FSCOORD works closely with the AMC to plan responsive FS for the air assault security operation. To ensure unity of effort, the AMC controls aviation units and FS operations from PZ to LZ. When cavalry or attack units are integrated into the scheme of maneuver for the ground tactical plan, the AMC ensures that a seamless transition to those roles is planned. He must direct the subordinate aviation unit commander to conduct face to face coordination with the ground maneuver commander/S-3 to get the commander's intent, scheme of maneuver, FS plan, graphics, frequencies, and call signs. Additionally, the subordinate commander must attend and be a part of the ground force's rehearsals. The AMC also plans for CSAR operations as part of the security effort.

c. Attack Helicopter Unit Commander. The attack helicopter unit commander works with the AMC to plan security operations for the AATF. Planning considerations include SEAD, overwatching the front, flank, and rear of AATF serials moving along air routes to protect against air or ground threats, providing overwatch or suppressive fires in and around the PZs/LZs, blocking enemy forces attempting to attack the AATF, and security for CSAR or MEDEVAC/CASEVAC operations. Relief on station operations may have to be planned to provide continuous security for large air assault operations. When cavalry assets are unavailable, the attack helicopter unit commander may also be required to plan for reconnaissance/security operations in support the AATF.

d. Air Cavalry/Reconnaissance Unit Commander. The air cavalry unit commander plans support for passage of lines, screening of PZs and LZs, reconnaissance of routes in advance of the AATF, and security for CSAR or MEDEVAC/CASEVAC operations. Relief on station operations may have to be planned to provide continuous security for large air assault operations. If attack helicopter units are unavailable, the air cavalry unit commander may be required to plan attack operations in support of the AATF.

e. CSAR Element Commander. The CSAR element commander, when appointed, plans for the employment of his force to recover downed personnel, and secure, recover, repair, or destroy downed aircraft. First priority in planning goes to recovery of downed personnel using assault, cargo or MEDEVAC/CASEVAC aircraft. Planning includes employment of attack helicopters to provide security during personnel extractions and aircraft recoveries. The CSAR element commander also plans for employment of the ground security force to secure downed aircraft while maintenance personnel perform repairs or rig it for recovery. His assets provide security for aircraft recovery operations and destroy downed aircraft when directed by proper authority.

B-5. BATTLE COMMAND

a. Command. The AATFC commands and controls the air assault operation. During the air assault operation, air cavalry/reconnaissance and attack units are under OPCON of the AATFC. However, during the movement of the AATF between PZ and LZ, the AATFC normally places these forces under OPCON of the AMC to ensure unity of effort for all aviation assets.

b. Control. The AMC fights the battle during movement of the AATF from PZ to LZ. In this role, the AMC controls all aviation units and supporting fires to ensure unity of the air assault security effort. To accomplish this task, the AMC normally positions himself where he can best control all aviation forces. In a small operation, he may be part of the assault element. However, with a larger AATF comprised of several different serials and a large security force, the AMC may position himself apart from the assault elements to control the operation more effectively. The AMC makes this determination in conjunction with the AATFC. He is normally located aboard the same aircraft as the AATF commander or AATF S3. Control of the operation is aided by the use of execution check lists or matrices with brevity code words. Communications between the AMC and other aviation elements normally include early warning and required situation reports. These reports should be passed using the brevity codes to reduce communications traffic.

c. Communications Nets. The AMC maintains communication with the AATFC and all aviation elements dedicated to the air assault and security operations. Figure B-1 shows the radio nets used for air assault security operations.

(1) Air assault TF command net. This is a secure FM net used by the AATFC to control the air assault operation. The AMC, if not actually located with the AATFC, communicates with him on this net. Commanders of assault, cargo, cavalry/reconnaissance, and attack units monitor this net.

(2) ABN. The AMC uses the ABN as his primary net for controlling security operations between PZ and LZ. The ABN is normally a UHF air-to-air net dedicated to communications between the AMC and all other aviation element commanders. This net is normally operated on the AMC's UHF command frequency. The AATFC may elect to operate on this net while he is airborne.

(3) Aviation internal net. These are normally VHF plain voice or FM secure nets used by each subordinate aviation element commander to control his individual aircraft.

(4) FS net. This is an FM secure net operated by the AATFC FSCOORD. Aviation elements do not normally monitor this net, but may enter it to transmit calls for fire during movements, insertions, and extractions. AFSOs and the security element supporting air assault security operations monitor this net continuously.

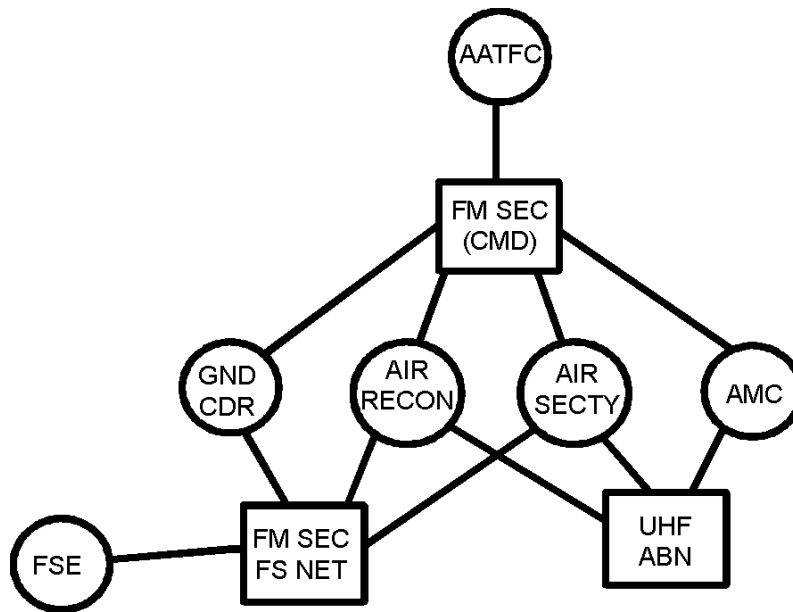

NOTE: Aviation units will use VHF internal.

Figure B-1. Air assault communications nets

(5) **CAN.** Although this net is not specifically used for air assault security operations, it may be when attack or cavalry assets are used to support the ground tactical plan. This is an FM secure net dedicated to air-to-ground coordination during air assault operations. Though it may be used as an alternate TF command net, it is dedicated primarily for communications between supporting aircraft and the lifted ground units. Aviation security element commanders may monitor this net within the limits of their capabilities during pickup and LZ operations.

B-6. AIR ASSAULT SECURITY TTP

a. General. The air assault security force is normally composed of a reconnaissance element and a security element. Air assault operations consist of five plans or phases; staging, loading, air movement, landing, and ground tactical plans. A phase may be conducted more than once during an operation. An example of this would be a multi-lift operation or the extraction of the assaulting force. Each phase may require various levels of air assault security for the AATF. The level of security for each phase is determined by METT-T. During the planning phase the AMC plans the synchronization of the aviation assets and various electronic and FS systems to suppress any threat.

b. Staging Phase. Air assault security for the staging plan encompasses aerial reconnaissance and screening operations. During or prior to this phase, the reconnaissance element may conduct reconnaissance of air axes or routes, LZ/PZs, and laager sites. Ideally the reconnaissance should be conducted early enough to provide input during the planning process. The reconnaissance can be conducted from key observation points along the route, thus avoiding activity directly on the intended route. If the reconnaissance elements spot the enemy, the mission may switch to surveillance to help develop the situation. It is imperative that the element remains undetected because it is crucial that the air assault operation's element of surprise is not compromised. The use of UAVs will enhance intelligence collection and OPSEC. If cavalry or attack assets are available, they can screen the ground unit's movement from their present location to a staging location and on to the PZ area.

c. Loading Phase.

(1) Security of the PZ is of critical importance. The air assault TF is vulnerable during this stage due to the massing of troops and aircraft. Security operations preclude enemy forces from attacking the TF during one of its most vulnerable times. PZs located in the rear are generally secure and may not require aviation security elements integrated with the ground security force. PZs beyond the FLOT must be regarded as not secure. The AATFC determines the security requirements for the PZ. Aviation security elements may augment and support the ground security elements around the PZ by screening a vulnerable flank or likely avenues of approach.

(2) If enemy contact is likely during this stage, the ground cavalry/ reconnaissance troops are well suited to provide additional security. The reconnaissance element may precede the arrival of the assault aircraft to the PZ; however, all measures should be taken to avoid creating a signature around the PZ. Coordination between the ground and aviation security elements is necessary when they collectively provide security for the ground forces in the PZ. The AMC and the PZ control officer must delineate fire control measures, sectors of responsibility, and C³ between the ground and air security elements. If attack aircraft are used during this phase of the air assault, they may need to conduct relief on station or FARP operations to ensure they have sufficient station time to conduct follow on missions.

d. Air Movement Phase.

(1) Air assault security for the air movement plan is finalized prior to the AMB. The AMC "fights the battle" from the PZ to the LZ while keeping the AATFC informed. The AMC employs artillery, attack, and reconnaissance elements according to the AATFC's intent. The AMC determines the tactical flight formations of the assault aircraft and the placement of the security and reconnaissance elements. The air assault security force must be aggressive and sufficiently removed from the main body to provide reaction time and maneuver space.

FM 1-112

(2) Normally, security elements do not "escort" the assault and cargo aircraft from the PZ to the LZ. Based on METT-T, AATF planners may decide to employ a portion of the aircraft in the security force to move along the air route with the assault aircraft. Particularly during escorts, air assault security force elements must be briefed about actions on contact. The security element may not always react to suppress each enemy target, especially if they do not pose a threat to the AATF. Assault/cargo helicopters may suppress using overlapping fires with their door guns, perform evasive maneuvers, and report to subsequent serials to avoid that area. These actions must be planned from PZ departure, along the route or axis, landing into the LZ, departing the LZ, and the route back so they can destroy, attrit, disrupt, or avoid contact with the threat according to the AATFC's intent.

(3) When developing actions on contact, consideration must be given to the type of formation to be flown, location of the attack helicopters, commands or code words to deconflict evasive maneuvers and suppressive fires from both attack helicopters and assault/cargo helicopter door gunners, and link-up procedures. Consideration must also be given to equipping the security force with adequate direct and indirect FS.

(4) The reconnaissance element precedes the departure of the flight from the PZ to perform a route reconnaissance or confirm a previous UAV reconnaissance of the route or axis. Additionally, the reconnaissance element can assist passage of lines for cross-FLOT air assault operations. Following the route reconnaissance, the reconnaissance element will perform an area reconnaissance of the primary and alternate LZs and possibly the objective depending on METT-T and the OPSEC intent of the AATF commander. Reconnaissance elements should spend minimal time (one pass) near selected primary and alternate LZs to prevent compromise and retain surprise. The time separation between the reconnaissance element and the flight is determined by the reconnaissance's level of detail and the mission tasks given to the reconnaissance element. For example, the AATFC may want the reconnaissance element in place several minutes in advance of the lead serials to ensure a smooth battle handover to the security elements and to observe and adjust FS for the LZ. The time sequence between the reconnaissance element and the lead serials must be carefully planned to prevent the main body from over-flying the reconnaissance element. Additional tasks for the reconnaissance element may include LZ suppression, screening the LZ and/or performing reconnaissance of the return route.

(5) The security element provides early warning of the enemy's approach and engages the enemy with organic fires under the ROE established by the AATFC and AMC. As the AATF departs the PZ, the security element maintains overwatch of the main body to deny observation, attack, or attrition of friendly units. The security element performs a moving screen or provides overwatch from successive battle positions of the main body from the PZ to the LZ and back. Again, the timing of this operation must be planned in detail to ensure that the assault elements do not outrun the security element. The security element may be positioned on the flanks of the main body and far enough to the front and rear to provide early warning, reaction time, and maneuver space. The distance between the flight and the security element is driven by

terrain and the range of enemy direct fire weapons systems. Screen operations may transition to guard operations for short durations to deny the enemy direct observation and/or fire against the AATF. Air combat operations are an implied task for the security element. The AMC determines type and/or combinations of the moving screen and overwatch based on METT-T and the AATFC's intent.

e. Landing Phase. The AATF is almost always in close proximity to the enemy, flying slow, and in a tight formation as they land in the LZ. When it is time to lift or shift indirect fires, attack helicopters and/or door gunners on board the assault helicopters may provide suppressive fires in and around the LZ. FS plans and coordinating measures must be thoroughly planned and coordinated among all members of the AATF.

(1) AMC responsibilities. The AMC must take into account air routes, go-around procedures, mission abort criteria, laager sites, and alternate LZ criteria and procedures. False insertions may enhance the overall security of the air assault operation particularly during the landing phase.

(2) Reconnaissance element. The reconnaissance element will complete an area reconnaissance of the primary and alternate LZs and relay results to the AMC and AATFC on the command net prior to the arrival of the AATF. The information provided by the reconnaissance element may drive certain contingencies built in the air assault OPLAN such as alternate LZ utilization. The reconnaissance element may control LZ preparatory fires, suppress targets on or near the LZ, and generally perform the same tasks of screening and overwatch as it did during the loading phase. The security element may screen or provide overwatch of the LZs in conjunction with the reconnaissance element, accept a battle handover, or continue the moving screen and/or overwatch of the return flight.

(3) Security element. The security element must use its maximum standoff capability from the LZ/objective area to reduce the risk of midair collisions. This standoff will make it harder to identify friend or foe on the ground so the plan must include fratricide reduction measures. The planner must consider the amount of ammunition that the en route security element may expend when deciding which element is going to provide security in the objective area. The AMC and the AATFC must establish sectors of responsibility among the air assault security force elements and the ground forces on the LZ.

f. Ground Tactical Phase. The transition from landing plan to ground tactical plan is important. Air assault security forces may depart with the assault helicopters to secure the return route, continue to provide screening operations for the ground force, screen an assault helicopter laager site or any combination of the three. Some consideration should be given to the possible emergency extraction of the ground force. The AMC must coordinate a smooth transfer of C² of aviation assets to the ground force commander if the security element is employed to support the ground scheme of maneuver.

FM 1-112

g. CS/CSS. The decision to use MEDEVAC aircraft to evacuate the wounded is based on the level of threat and the anticipated need for immediate medical treatment. If the duration of the mission exceeds the endurance of the aviation assets, consideration must be given to FARP operations, FARP security and relief on station requirements.

B-6. AIR ASSAULT SECURITY PLANNING CHECKLIST

Air Assault Security Planning Checklist

1. SITUATION

a. Analyze enemy, terrain and weather in area of operations, security forces available, and time available to plan security operations

(1) Known or potential enemy AD and maneuver unit locations.

(2) Potential threat from armed helicopters or high performance aircraft.

(3) Aerial reconnaissance of PZs, LZs and air routes including ground avenues of approach, obstacles to flight, key terrain, observation and fields of fire, and cover and concealment.

(4) Weather reports to determine effects of weather on terrain and security operations.

b. Assemble security elements, and begin planning for operation.

(1) Attack helicopter unit.

(2) Air cavalry/reconnaissance unit.

(3) CSAR TF.

(4) FSCoord.

(5) ALO.

2. MISSION

a. Analyze the mission and the AATFC's intent to determine the level of security required for the given mission.

b. Issue a WARNORD and preliminary planning time guidance to all subordinate elements.

3. EXECUTION

- a.** Develop own commander's intent/guidance for the mission.
- b.** Develop scheme of maneuver for reconnaissance and security elements.
 - (1)** Plan flight routes, battle positions, overwatch positions, screen traces.
 - (2)** Coordinate/deconflict direct fire control measures.
- c.** Develop specific tasks for subordinate units.
 - (1)** Reconnaissance elements.
 - (a)** Example missions.
 - Route reconnaissance.
 - Area reconnaissance of PZ/LZ/objective areas.
 - (b)** Assets.
 - Air cavalry units.
 - Ground cavalry units.
 - Attack helicopter units.
 - UAVs.
 - (2)** Security elements.
 - (a)** Example Missions.
 - Screen staging area/PZ.
 - Screen/overwatch flight routes.
 - Screen/overwatch LZ/objective areas.
 - Conduct hasty attacks in support of the ground tactical plan.
 - Control FS for the operation.

FM 1-112

(b) Assets.

- Attack Helicopter units.
- Air Cavalry units.
- Ground Cavalry units.

(3) FS.

- Plan SEAD at the passage point.
- Plan deceptive SEAD/obscuration.
- Plan suppression of known enemy positions en route and in the objective area.

(4) EW.

- Plan ECM (Jam enemy FS, ADA, C² nets).
- Plan ESM (Target enemy FS, ADA, C² communication sites).

4. SERVICE SUPPORT

- a.** FARP locations.
- b.** Relief on station requirements.
- c.** Ammunition loads.
- d.** CSAR/DART.

5. COMMAND AND SIGNAL

- a.** AMC Location.
- b.** Ground force commander location.
- c.** Frequencies and call signs.
- d.** Brevity code words.
- e.** Transition from AMC control to ground force control if required.

APPENDIX C

SAMPLE ORDER AND MISSION BRIEFING FORMATS

C-1. WARNORD

Figure C-1 shows a sample format for a WARNORD.

| |
|---|
| <ol style="list-style-type: none">1. SITUATION<ol style="list-style-type: none">a. Brief statement about the enemy and friendly situation.b. Attachments and detachments.2. MISSION (Who, What, When, Where, and Why)3. COORDINATING INSTRUCTIONS<ol style="list-style-type: none">a. Number of aircraft and crew required.b. Aircraft load,ammunition, fuel, and cargo or passengers.c. Special-mission equipment.d. Mission-oriented protective posture.e. Earliest time of movement (crank-up and load-up).f. Changes to SOP.4. SPECIFIC INSTRUCTIONS<ol style="list-style-type: none">a. Chain of command.b. Weather (who gets it).c. Flight plan (who files it and when).d. Coordination, liaison, or special individual tasks.5. TIME AND PLACE FOR ISSUANCE OF THE OPERATION ORDER<ol style="list-style-type: none">a. Location.b. Time.c. Personnel to attend.6. OTHER<ol style="list-style-type: none">a. Time is now _____.b. What are your questions? |
|---|

Figure C-1. WARNORD sample format

C-2. OPORDs

- a. Figure C-2 shows a OPORD sample format for attack operations.

| | |
|--|--|
| | Copy_of_Copies Issuing Headquarters Place(grid), country DTG Message Reference No. |
| OPERATION ORDER____(code name, if used) REFERENCE(S): Time zone used throughout the order: | |
| TASK ORGANIZATION | |
| 1. Situation: | |
| a. Enemy Forces. | |
| (1) Enemy. | |
| (a) ID of enemy forces. | |
| (b) Activity of enemy forces. | |
| (c) Location. | |
| (d) Disposition. | |
| (e) Strength. | |
| (f) Composition to include equipment | |
| (g) Previous actions. | |
| (h) Probable courses of action. | |
| (i) Terrorist actions/threat (if applicable). | |
| (2) Weather. | |
| (a) Current weather, IR, and light data/moon illumination. | |
| (b) Forecast weather for operation. | |
| (c) Special environmental considerations or hazards. | |
| (d) Effects of weather on enemy and friendly actions | |
| (3) Terrain. | |
| (a) Observation. | |
| (b) Cover and Concealment. | |
| (c) Avenues of Approach. | |
| (1) Size of unit supported. | |
| (2) Start/End points. | |
| (3) Objective it leads to. | |
| (d) Engagement Areas. | |
| (e) Effects of terrain on enemy and friendly actions. | |

Figure C-2. OPORD sample format

b. Friendly Forces.

- (a) Mission/intent of higher HQ.
- (b) Adjacent units.
- (c) Supported and supporting units.
- (d) Other aviation elements in area of operations.

c. Attachments and Detachments.

2. MISSION: Who, what, when, where, and why.

3. EXECUTION:

INTENT:

- (a) Purpose of mission.
- (b) Method to achieve purpose.
- (c) Endstate--Success criteria (specific numbers or percentage of enemy destroyed, etc).

a. Concept of the Operation. Annex__(Operation Overlay).

1. Maneuver.

- (a) How all units will be employed.
- (b) Identify main and supporting attacks.

2. Fire Support.

- (a) SEAD fires: Who controls, time or event driven.
- (b) Priority of fires.
- (c) Location of FA units, G/T lines, proposed/priority targets.
- (d) Planned fires.
- (e) Naval gunfire (if applicable).

3. Counter-air operations.

- (a) Concept of counter-air operations.
- (b) Weapons control status.

4. Intelligence. Provide priorities of collection.

5. Electronic warfare. Establish priority of collection and jamming.

6. Engineer.

7. Tac Air Support Plan.

- (a) Routes and IPs.
- (b) Time on Station.
- (c) Targets.

b. Tasks to Maneuver Units.

(1) List all maneuver units (ground and aviation) that report directly to the HQ issuing the order or plan. Use a separate sub-subparagraph for each maneuver unit. List units in order in which they appear in the task organization.

(2) State missions or tasks and purposes to be accomplished.

Figure C-2. OPORD sample format (continued)

| | |
|---------------------|--|
| | <p>(3) Do not repeat tasks otherwise shown on the overlay or stated in sub-subparagraph 3a(1) or in coordinating instructions.</p> <p>(4) Do not list tactical tasks that affect two or more units. These should be in coordinating instructions or 3a(1).</p> |
| | <p>c. Tasks to Combat Support Units.</p> <p>(1) List specific missions for each subordinate unit, including attached units.</p> <p>(2) Include organization for combat if not clear in task organization.</p> |
| | <p>d. Coordinating Instructions.</p> <p>(1) Commander's critical information requirements.</p> <ul style="list-style-type: none">(a) PIR.(b) EEFI.(c) FFIR. <p>(2) Target Priority.</p> <p>(3) Time schedule.</p> <ul style="list-style-type: none">(a) Stand-to, Precombat checks.(b) Mission/intel update time and place.(c) Start.(d) Communication check.(e) Lineup.(f) Takeoff.(g) On-station time.(h) Relief-on-station time(i) Inspections and rehearsals. <p>(4) Flight plan filing.</p> <p>(5) Ammunition configuration by aircraft and type.</p> <p>(6) Flight coordination.</p> |
| turn-on/off points. | <p>(a) Air routes/corridors(primary and alternate), ACPs, SPs, route names, rally points, and ASE</p> |
| sketch or photo). | <p>(b) Traffic patterns: FARPs, battalion AA, FAA, other.</p> <p>(c) Holding areas, FAAs, FARPs, and battle positions (name, locations, marking and control, and</p> |
| section). | <p>(d) Doppler presets.</p> <p>(e) Mode of flight, airspeed, heading, and altitude for each leg of flight.</p> <p>(f) Movement technique and formation for occupation of HA/BP/ABF/SBF.</p> <p>(g) Direction into BP/ABF/SBF and scheme of maneuver for occupation (light/heavy</p> <p>(h) Coordinating altitude and other airspace procedural control measures.</p> <p>(i) Aircraft lighting.</p> <p>(j) IMC breakup procedures.</p> <p>(k) Underwire/under bridge flight.</p> <p>(l) Aircraft in-flight emergency procedure to include recovery points/airfields.</p> <p>(m) Flight following.</p> |

Figure C-2. OPORD sample format (continued)

- (7) Crew endurance.
- (8) Electronic counter-countermeasures (ECCM).
- (9) MOPP.
- (10) OEG.
- (11) Actions on contact.
- (12) Rules of Engagement (ROE).
- (13) Authorized mode of operations with degraded weapons/NVD.
- (14) IFF on/off line.
- (15) Downed aircraft procedures.
 - (a) Aircraft destruction criteria, authority, and procedures.
 - (b) Downed aircrew procedures, pickup points, and times.
- (16) EEI/required FLASH reports.
- (17) Abort Criteria.
- (18) Debriefing time and place.

4. SERVICE SUPPORT

a. Supply.

- (1) Class I.
- (2) Location of FARPs and priority of use.
- (3) Configuration of class III and class V resupply areas/# of points (use sketch).
- (4) Class IX.
- (5) Other classes of supply.

b. Services and Transportation.

- (1) Location of AVUM/Contact teams.
- (2) Downed aircraft/aircrew recovery procedures.
- (3) Road march and convoy procedures.

c. Medical and Personnel Services.

- (1) Location of Bn aid station.
- (2) Air-ground medical evacuation procedures.
- (3) Decontamination site.

Figure C-2. OPORD sample format (continued)

5. COMMAND and SIGNAL

a. Command.

- (1) Chain of command.
- (2) Current and proposed locations TAC, main, and rear CPs.
- (3) Succession of command.

b. Signal.

- (1) Signal operation instructions in effect.
- (2) Secure radio codes.
- (3) Laser Codes.
- (4) Code word or password.
- (5) Meaconing, intrusion, jamming, and electronic counter-countermeasures.
- (6) Lost communications procedures.
- (7) TACAIR, JAAT, and FS frequencies.
- (8) Tactical beacons and navigational aids.
- (9) Frequencies.
- (10) Comm Card/base letter/authentication line.
- (11) Hush status.

Acknowledge.

Commanders Signature (optional)
Commanders Last Name
Rank

OFFICIAL:
S3's Name
S3's Rank

Annexes: List all annexes in the order in which they appear alphabetically (See FM 101-5 for proper designation).

NOTE 1: All aircrews will have complete graphics. Platoon Leaders will conduct spot inspections.

NOTE 2: Ensure mission brief is completed before departure. Air mission commander will review form for correct entries.

Figure C-2. OPORD sample format (concluded)

b. Figure C-3 shows a OPORD sample format for reconnaissance operations.

| | |
|--|--|
| | Copy_of_Copies Issuing Headquarters Place(grid), country DTG Message Reference No. |
| <p>OPERATION ORDER____(code name, if used) REFERENCE(S): Time zone used throughout the order:</p> <p>TASK ORGANIZATION</p> <p>1. Situation:</p> <p style="margin-left: 20px;">a. Enemy Forces.</p> <p style="margin-left: 40px;">(1) Enemy.</p> <p style="margin-left: 60px;">(a) ID of enemy forces. (b) Activity of enemy forces. (c) Location. (d) Disposition. (e) Strength. (f) Composition to include equipment. (g) Previous actions. (h) Probable courses of action. (i) Terrorist actions/threat (if applicable).</p> <p style="margin-left: 40px;">(2) Weather.</p> <p style="margin-left: 60px;">(a) Current weather, IR, and light data/moon illumination. (b) Forecast weather for operation. (c) Special environmental considerations or hazards. (d) Effects of weather on enemy and friendly actions.</p> <p style="margin-left: 40px;">(3) Terrain.</p> <p style="margin-left: 60px;">(a) Observation. (b) Cover and Concealment. (c) Avenues of Approach. (1) Size unit supported. (2) Start/End points. (3) Objective it leads to. (d) Objective. (e) Effects of terrain on enemy and friendly actions.</p> | |

Figure C-3. OPORD sample format, reconnaissance mission

- b. Friendly Forces.
 - (a) Mission/intent of higher HQ.
 - (b) Adjacent units.
 - (c) Supported and supporting units.
 - (d) Other aviation elements in area of operations.
- c. Attachments and Detachments.
- 2. MISSION: Who, what (route, zone, area), when, where, and why.
- 3. EXECUTION:
 - INTENT:
 - (a) Purpose of mission.
 - (b) Method to achieve purpose.
 - (c) Endstate--Success criteria (specific numbers or percentage of enemy destroyed, etc).
 - a. Concept of the Operation. Annex__(Operation Overlay).
 - 1. Maneuver.
 - (a) How all units will be employed.
 - (b) Identify main and supporting attacks.
 - 2. Fire Support.
 - (a) Priority of fires.
 - (b) Location of FA units, G/T lines, proposed/priority targets.
 - (c) Planned fires.
 - (d) Naval gunfire (if applicable).
 - 3. Counter-air operations.
 - (a) Concept of counter-air operations.
 - (b) Weapons control status.
 - 4. Intelligence. Provide priorities of collection.
 - 5. Electronic warfare. Establish priority of collection and jamming.
 - 6. Engineer.
 - 7. Tac Air Support Plan.
 - (a) Routes and IPs.
 - (b) Time on Station.
 - (c) Targets.
 - b. Tasks to Maneuver Units.
 - (1) List all maneuver units (ground and aviation) that report directly to the HQ issuing the order or plan. Use a separate sub-subparagraph for each maneuver unit. List units in order in which they appear in the task organization.
 - (2) State missions or tasks and purposes to be accomplished.

Figure C-3. OPORD sample format, reconnaissance mission (continued)

- (3) Do not repeat tasks otherwise shown on the overlay or stated in sub-subparagraph 3a(1) or in coordinating instructions.
 - (4) Do not list tactical tasks that affect two or more units. These should be in coordinating instructions or 3a(1).
- c. Task to Combat Support Units.
- (1) List specific missions for each subordinate unit, including attached units.
 - (2) Include organization for combat if not clear in task organization.
- d. Coordinating Instructions.
- (1) Commander's critical information requirements.
 - (a) PIR.
 - (b) EEFI.
 - (c) FFIR.
 - (2) Target Priority.
 - (3) Time schedule.
 - (a) Stand-to, Pre-combat checks.
 - (b) Mission/intel update time and place.
 - (c) Start.
 - (d) Communication check.
 - (e) Lineup.
 - (f) Takeoff.
 - (g) LD time.
 - (h) Inspections and rehearsals.
 - (4) Flight plan filing.
 - (5) Ammunition configuration by aircraft and type.
 - (6) Flight coordination.
 - (a) Air routes/corridors(primary and alternate), ACPs, SPs, release points, passage points, route names, rally points, and ASE turn-on/off points.
 - (b) Traffic patterns: FARPs, battalion tactical CP, other.
 - (c) Objective, holding areas, FAAs, FARPs, overwatch positions, phase-lines and battle positions (name, locations, marking and control, and sketch or photo).
 - (d) Doppler presets.
 - (e) Mode of flight, airspeed, heading, and altitude for each leg of flight.

Figure C-3. OPORD sample format, reconnaissance mission (continued)

- (f) Movement technique and formation for occupation of HA/BP/OPs.
 - (g) Direction into BP/OPs and scheme of maneuver for occupation (light/heavy section).
 - (h) Coordinating altitude and other airspace procedural control measures.
 - (i) Aircraft lighting.
 - (j) IMC breakup procedures.
 - (k) Underwire/under bridge flight.
 - (l) Aircraft in-flight emergency procedure to include recovery points/airfields.
 - (m) Flight following.
- (7) Crew endurance.
 - (8) Electronic counter-countermeasures).
 - (9) MOPP.
 - (10) OEG.
 - (11) Actions on contact.
 - (12) Actions at the objective.
 - (13) Rules of Engagement.
 - (14) Authorized mode of operations with degraded weapons/NVD.
 - (15) IFF on/off line.
 - (16) Downed aircraft procedures.
 - (a) Aircraft destruction criteria, authority, and procedures.
 - (b) Downed aircrew procedures, pickup points, and times.
 - (17) EEI/required FLASH reports.
 - (18) Abort Criteria.
 - (19) Debriefing time and place.
4. SERVICE SUPPORT
- a. Supply.
 - (1) Class I.
 - (2) Location of FARPs and priority of use.
 - (3) Configuration of class III and class V resupply areas/# of points (use sketch).
 - (4) Class IX.
 - (5) Other classes of supply.
 - b. Services and Transportation.
 - (1) Location of AVUM/Contact teams.
 - (2) Downed aircraft/aircrew recovery procedures.
 - (3) Road march and convoy procedures.

Figure C-3. OPORD sample format, reconnaissance mission (continued)

c. Medical and Personnel Services.

- (1) Location of Bn aid station.
- (2) Air-ground medical evacuation procedures.
- (3) Decontamination site.

5. COMMAND and SIGNAL

a. Command.

- (1) Chain of command.
- (2) Current and proposed locations TAC, main, and rear CPs.
- (3) Succession of command.

b. Signal

- (1) Signal operation instructions in effect.
- (2) Secure radio codes.
- (3) Laser Codes.
- (4) Code word or password.
- (5) Meaconing, intrusion, jamming, and electronic counter-countermeasures.
- (6) Lost communications procedures.
- (7) TACAIR, JAAT, and FS frequencies.
- (8) Tactical beacons and navigational aids.
- (9) Frequencies.
- (10) Comm Card/base letter/authentication line.
- (11) Hush status.

Acknowledge.

Commanders Signature (optional)
Commanders Last Name
Rank

OFFICIAL:
S3's Name
S3's Rank

Annexes: List all annexes in the order in which they appear alphabetically.

NOTE 1: All aircrews will have complete graphics. Platoon Leaders will conduct spot inspections.

NOTE 2: Ensure mission brief is completed before departure. Air mission commander will review form for correct entries.

Figure C-3. OPORD sample format, reconnaissance mission (continued)

c. Figure C-4. shows a OPORD sample format for security operations.

| | |
|--|--|
| | Copy_of_Copies Issuing Headquarters Place(grid), country DTG Message Reference No. |
| OPERATION ORDER____(code name, if used) REFERENCE(S): Time zone used throughout the order: | |
| TASK ORGANIZATION | |
| 1. Situation: | |
| a. Enemy Forces. | |
| (1) Enemy. | |
| (a) ID of enemy forces. | |
| (b) Activity of enemy forces. | |
| (c) Location. | |
| (d) Disposition. | |
| (e) Strength. | |
| (f) Composition to include equipment. | |
| (g) Previous actions. | |
| (h) Probable courses of action. | |
| (i) Terrorist actions/threat (if applicable). | |
| (2) Weather. | |
| (a) Current weather, IR, and light data/moon illumination. | |
| (b) Forecast weather for operation. | |
| (c) Special environmental considerations or hazards. | |
| (d) Effects of weather on enemy and friendly actions. | |
| (3) Terrain. | |
| (a) Observation. | |
| (b) Cover and Concealment. | |
| (c) Avenues of Approach. | |
| (1) Size unit supported. | |
| (2) Start/End points. | |
| (3) Objective it leads to. | |
| (d) Engagement Areas. | |
| (e) Effects of terrain on enemy and friendly actions. | |

Figure C-4. OPORD sample format, security missions

- b. Friendly Forces.
 - (a) Mission/intent of higher HQ.
 - (b) Adjacent units.
 - (c) Supported and supporting units.
 - (d) Other aviation elements in area of operations.
- c. Attachments and Detachments.
- 2. MISSION: Who, what (screen, guard, cover), when, where, and why.
- 3. EXECUTION:
 - INTENT:
 - (a) Purpose of mission.
 - (b) Method to achieve purpose.
 - (c) Endstate--Success criteria (specific numbers or percentage of enemy destroyed, etc).
 - a. Concept of the Operation. Annex__(Operation Overlay).
 - 1. Maneuver.
 - (a) How all units will be employed.
 - (b) Identify main and supporting efforts.
 - 2. Fire Support (normally not available for cover missions).
 - (a) Priority of fires.
 - (b) Location of FA units, G/T lines, proposed/priority targets.
 - (c) Planned fires.
 - (d) Naval gunfire (if applicable).
 - 3. Counter-air operations.
 - (a) Concept of counter-air operations.
 - (b) Weapons control status.
 - 4. Intelligence. Provide priorities of collection.
 - 5. Electronic warfare. Establish priority of collection and jamming.
 - 6. Engineer.
 - 7. Tac Air Support Plan.
 - (a) Routes and IPs.
 - (b) Time on Station.
 - (c) Targets.
 - b. Tasks to Maneuver Units.
 - (1) List all maneuver units (ground and aviation) that report directly to the HQ issuing the order or plan. Use a separate sub-subparagraph for each maneuver unit. List units in order in which they appear in the task organization.
 - (2) State missions or tasks and purposes to be accomplished.

Figure C-4. OPORD sample format, security mission (continued)

- (3) Do not repeat tasks otherwise shown on the overlay or stated in sub-subparagraph 3a(1) or in coordinating instructions.
- (4) Do not list tactical tasks that affect two or more units. These should be in coordinating instructions or 3a(1).
- c. Task to Combat Support Units.
 - (1) List specific missions for each subordinate unit, including attached units.
 - (2) Include organization for combat if not clear in task organization.
- d. Coordinating Instructions.
 - (1) Commander's critical information requirements(CCIR).
 - (a) PIR.
 - (b) EEFI.
 - (c) FFIR.
 - (2) Target Priority.
 - (3) Time schedule.
 - (a) Stand-to, Precombat checks.
 - (b) Mission/Intel update time and place.
 - (c) Start.
 - (d) Communication check.
 - (e) Lineup.
 - (f) Takeoff.
 - (g) LD time.
 - (h) Inspections and rehearsals.
 - (4) Flight plan filing.
 - (5) Ammunition configuration by aircraft and type.
 - (6) Flight coordination.
 - (a) Air routes/corridors(primary and alternate), ACPs, SPs, release points, passage points,route names, rally points, and ASE turn-on/off points.
 - (b) Traffic patterns: FARPs, battalion tactical CP, other.
 - (c) Objective, holding areas, FAAs, FARPs, overwatch positions, phase-lines and battle positions (name, locations, marking and control, and sketch or photo).
 - (d) Doppler presets.
 - (e) Mode of flight, airspeed, heading, and altitude for each leg of flight.

Figure C-4. OPORD sample format, security mission (continued)

c. Medical and Personnel Services.

- (1) Location of Bn aid station.
- (2) Air-ground medical evacuation procedures.
- (3) Decontamination site.

5. COMMAND and SIGNAL

a. Command.

- (1) Chain of command.
- (2) Current and proposed locations TAC, main, and rear CPs.
- (3) Succession of command.

b. Signal.

- (1) Signal operation instructions in effect.
- (2) Secure radio codes.
- (3) Laser Codes.
- (4) Code word or password.
- (5) Meaconing, intrusion, jamming, and electronic counter-countermeasures.
- (6) Lost communications procedures.
- (7) TACAIR, JAAT, and FS frequencies.
- (8) Tactical beacons and navigational aids.
- (9) Frequencies.
- (10) Comm Card/base letter/authentication line.
- (11) Hush status.

Acknowledge.

Commanders Signature (optional)
Commanders Last Name
Rank

OFFICIAL:
S3's Name
S3's Rank

Annexes: List all annexes in the order in which they appear alphabetically.

NOTE 1: All aircrews will have complete graphics. Platoon leaders will conduct spot inspections.

NOTE 2: Ensure mission brief is completed before departure. Air mission commander will review form for correct entries.

Figure C-4. OPORD sample format, security mission (concluded)

FM 1-112

d. Figure C-5 shows a OPORD sample format for an air assault security operation.

| | |
|--|--|
| | Copy_of_Copies Issuing Headquarters Place(grid), country DTG Message Reference No. |
| OPERATION ORDER____(code name, if used) REFERENCE(S): Time zone used throughout the order: | |
| TASK ORGANIZATION | |
| 1. Situation: | |
| a. Enemy Forces. | |
| (1) Enemy. | |
| (a) ID of enemy forces. | |
| (b) Activity of enemy forces. | |
| (c) Location. | |
| (d) Disposition. | |
| (e) Strength. | |
| (f) Composition to include equipment. | |
| (g) Previous actions. | |
| (h) Probable courses of action. | |
| (i) Terrorist actions/threat (if applicable). | |
| (2) Weather. | |
| (a) Current weather, IR, and light data/moon illumination. | |
| (b) Forecast weather for operation. | |
| (c) Special environmental considerations or hazards. | |
| (d) Effects of weather on enemy and friendly actions. | |
| (3) Terrain. | |
| (a) Observation. | |
| (b) Cover and Concealment. | |
| (c) Avenues of Approach. | |
| (1) Size of unit supported. | |
| (2) Start/End points. | |
| (3) Objective it leads to. | |
| (d) Engagement Areas. | |
| (e) Effects of terrain on enemy and friendly actions. | |

Figure C-5. OPORD sample format, AASLT security

- b. Friendly Forces.
 - (a) Mission/intent of higher HQ.
 - (b) AATFC's mission/intent.
 - (c) Adjacent.
 - (d) Other aviation elements in area of operations.

c. Attachments and Detachments.

2. MISSION: Who, what, when, where, and why. Analyze the mission and the AATFC's intent to determine the level of security required for the given mission.

3. EXECUTION:

INTENT:

- (a) Purpose of mission.
- (b) Method to achieve purpose.
- (c) Endstate--Success criteria (specific numbers or percentage of enemy destroyed, etc).

a. Concept of the Operation. Annex_(Operation Overlay).

1. Maneuver.

- (a) How all units will be employed to include the Ground Tactical Plan.
- (b) Identify main and supporting attacks.

2. Fire Support.

- (a) SEAD fires: Who controls, time or event driven.
- (b) Priority of fires.
- (c) Location of FA units, G/T lines, proposed/priority targets.
- (d) Planned fires.
- (e) Naval gunfire (if applicable).

3. Counter-air operations.

- (a) Concept of counter-air operations.
- (b) Weapons control status.

4. Intelligence. Provide priorities of collection.

5. Electronic warfare. Establish priority of collection and jamming.

6. Engineer.

7. Tac Air Support Plan.

- (a) Routes and IPs.
- (b) Time on Station.
- (c) Targets.

8. Deception plan.

9. Extraction plan.

b. Tasks to Maneuver Units.

- (1) List all maneuver units (ground and aviation) that report directly to the HQ issuing the order or plan. Use a separate sub-subparagraph for each maneuver unit. List units in order in which they appear in the task organization.
- (2) State missions or tasks and purposes to be accomplished.

Figure C-5. OPORD sample format, AASLT security (continued)

(3) Do not repeat tasks otherwise shown on the overlay or stated in sub-subparagraph 3a(1) or in coordinating instructions.

(4) Do not list tactical tasks that affect two or more units. These should be in coordinating instructions or 3a(1).

c. Task to Combat Support Units.

- (1) List specific missions for each subordinate unit, including attached units.
- (2) Include organization for combat if not clear in task organization.

d. Coordinating Instructions.

(1) Commander's critical information requirements(CCIR).

- (a) PIR.
 - (b) EEFI.
 - (c) FFIR.

(2) Target Priority.

(3) Time schedule.

- (a) Stand-to, Pre-combat checks.
- (b) Mission/Intel update time and place.
- (c) Start.
- (d) Communication check.
- (e) Lineup.
- (f) Takeoff.
- (g) PZ time.
- (h) LZ time
- (i) Inspections and rehearsals.

(4) Flight plan filing.

(5) Ammunition configuration by aircraft and type.

(6) Flight coordination.

- (a) Air routes/corridors (primary and alternate), ACPs, SPs, LZs, PZs, route names, rally points, and ASE turn-on points.
- (b) Traffic patterns: FARPs, battalion AA, FAA, PZs/LZs, other.
- (c) PZs, LZs, FAAs, FARPs, and OPs (name, locations, marking and control, and sketch or photo).
- (d) Doppler presets.
- (e) Mode of flight, airspeed, heading, and altitude for each leg of flight.
- (f) Movement technique and formation for occupation of BP, ABF, SBF, or OPs.
- (g) Direction into positions and scheme of maneuver for occupation.
- (h) Coordinating altitude and other airspace procedural control measures.
- (i) Aircraft lighting.
- (j) IMC breakup procedures.
- (k) Under wire/under bridge flight.
- (l) Aircraft in-flight emergency procedure to include recovery points/airfields.
- (m) Flight following.

Figure C-5. OPOD sample format, AASLT security (continued)

- (7) Crew endurance.
 - (8) Electronic counter-countermeasures (ECCM).
 - (9) MOPP/OEG.
 - (10) Actions at the PZ/LZ.
 - (11) Actions on contact.
 - (12) Link-up with assault aircraft.
 - (13) Rules of Engagement (ROE).
 - (14) Authorized mode of operations with degraded weapons/NVD.
 - (15) IFF on/off line.
 - (16) Downed aircraft procedures.
 - (a) Aircraft destruction criteria, authority, and procedures.
 - (b) Downed aircrew procedures, pickup points, and times.
 - (17) EEI/required FLASH reports.
 - (18) Abort Criteria.
 - (19) Debriefing time and place.
4. SERVICE SUPPORT
- a. Supply.
 - (1) Class I.
 - (2) Location of FARPs and priority of use.
 - (3) Configuration of class III and class V resupply areas/# of points (use sketch).
 - (4) Class IX.
 - (5) Other classes of supply.
 - b. Services and Transportation.
 - (1) Location of AVUM/Contact teams.
 - (2) Downed aircraft/aircrew recovery procedures.
 - (3) Road march and convoy procedures.
 - c. Medical and Personnel Services.
 - (1) Location of Bn aid station.
 - (2) Air-ground medical evacuation procedures.
 - (3) Decontamination site.

Figure C-5. OPORD sample format, AASLT security (continued)

5. COMMAND and SIGNAL

a. Command.

- (1) Chain of command.
- (2) Current and proposed locations TAC, main, and rear CPs.
- (3) Succession of command.

b. Signal.

- (1) Signal operation instructions in effect.
- (2) Secure radio codes.
- (3) Laser Codes.
- (4) Code word or password.
- (5) Meaconing, intrusion, jamming, and electronic counter-countermeasures.
- (6) Lost communications procedures.
- (7) TACAIR, JAAT, and FS frequencies.
- (8) Tactical beacons and navigational aids.
- (9) Frequencies.
- (10) Comm Card/base letter/authentication line.
- (11) Hush status.

Acknowledge.

Commanders Signature (optional)
Commanders Last Name
Rank

OFFICIAL:
S3's Name
S3's Rank

Annexes: List all annexes in the order in which they appear alphabetically.

NOTE 1: All aircrews will have complete graphics. Platoon Leaders will conduct spot inspections.

NOTE 2: Ensure mission brief is completed before departure. Air mission commander will review form for correct entries.

Figure C-5. OPORD sample format, AASLT security (concluded)

C-3. COMPANY MISSION BRIEF

a. Figure C-6 shows a sample format for a company mission brief.

| ROLL CALL/CREW ASSIGNMENT: | | | |
|--|------|----------|------|
| TM | ACFT | CALLSIGN | CREW |
| | | | |
| I. SITUATION | | | |
| 1. ENEMY: _____ | | | |
| 2. FRIENDLY: _____ | | | |
| 3. ATTCH/DETACH: _____ | | | |
| 4. WX/ILLUM: Void: _____ Ceiling: _____ Vis: _____ Winds: _____ PA: _____ DA: _____ % Illum: _____ | | | |
| SR: _____ SS: _____ MR: _____ MS: _____ EENT: _____ WX Warning: _____ | | | |
| II. Mission: _____ | | | |
| III. Execution: | | | |
| Intent: _____ | | | |
| 1. CONCEPT OF THE OPERATION: _____ | | | |
| A. MANEUVER: _____ | | | |
| B. FIRES: _____ | | | |
| C. FLT FOLLOW: _____ | | | |
| D. MVMNT INTO BP'S/BP LAYOUT/FIRE DISTRIBUTION: _____ | | | |
| E. <u>PP</u> <u>OPEN</u> <u>CONTROL/CALLSIGN</u> <u>FREQ</u> _____ . _____ _____ | | | |
| F. E&E/DPPP INST: _____ | | | |
| _____ ACTIVE: _____ TO: _____ | | | |
| _____ ACTIVE: _____ TO: _____ | | | |
| G. LASER CODES: | | | |
| <u>UNIT</u> <u>LT TM</u> <u>HVY TM</u> <u>UNIT</u> <u>LT TM</u> <u>HVY TM</u> _____ _____ _____ _____ _____ | | | |
| H. JATT/CAS | | | |
| Freq's: _____ IP1: _____ IP2: _____ IP3: _____ CALL SIGN: _____ | | | |
| I. RELIEF ON STATION: _____ | | | |

Figure C-6. Sample format for company mission brief

J. FLIGHT MODES:

| | A/S | ALTITUDE | FORMATION | MVMT TECHNIQUE |
|--------|-------|----------|-----------|----------------|
| 1ST CP | _____ | _____ | _____ | _____ |
| HA | _____ | _____ | _____ | _____ |
| LD | _____ | _____ | _____ | _____ |
| RP | _____ | _____ | _____ | _____ |
| BP | _____ | _____ | _____ | _____ |
| RTN | _____ | _____ | _____ | _____ |

K. RALLY POINTS: 1) _____ 2) _____ 3) _____

L. ACTIONS ON CONTACT: A) TO HA _____ B) IN HA _____
 C) TO BP _____ D) IN BP _____ E) _____

M. IMC BREAKUP: _____

N. TIME LINE: APU: _____ CRANK: _____ COMMO: _____
 LINEUP: _____ T/O: _____ BP'S: _____

O. AIRCRAFT LIGHTING: A) IN TAA _____ B) TO SP _____ C) TO HA _____ D) TO BP _____

P. A/C LOADS: _____

IV. SERVICE SUPPORT:

A. FARPs _____

B. MAINT: _____

C. CREW ENDURANCE: _____

V. COMMAND AND SIGNAL:

A. SUCCESSION OF COMMAND: _____

B. FREQS:

| | UNIT | CALL SIGN | FREQ |
|-----|-------|-----------|-------|
| BDE | _____ | _____ | _____ |
| BN | _____ | _____ | _____ |
| LT | _____ | _____ | _____ |
| HVY | _____ | _____ | _____ |
| F/S | _____ | _____ | _____ |

C. COMPANY FREQS: A) FM: _____ B) VHF: _____ C) UHF: _____

VI. 1. REHEARSAL: _____ 2. TIME HACK: _____

Figure C-6. Sample format for company mission brief (concluded)

C-4. MISSION DEBRIEF

Figure C-7 shows a sample format for company mission debrief.

| | |
|----|---|
| 1. | SITUATION |
| a. | Enemy Situation Encountered. |
| | (1) Size: Div__ Reg__ Bn__ Co__ Plt__ Sec__ Other_____. |
| | (2) Location (grid):_____. |
| | (3) Equipment Observed (type): ADA_____, ARMOR_____, APC_____, ARTILLERY_____, OTHER_____. |
| | (4) Enemy aircraft: Rotary-Wing_____, Fixed-Wing_____. |
| | (5) Enemy Formation(s):_____. |
| | (6) Enemy Actions on Contact:_____. |
| | (7) EW and OPSEC activities: Type_____, How_____. |
| | (8) Enemy Vehicles: Destroyed____, Damaged_____. |
| b. | Weather (significant differences to forecast). |
| | (1) Min/Max Ceiling:_____. |
| | (2) Min/Max Visibility:_____. |
| | (3) Hazards to flight encountered:_____. |
| | (4) Winds:_____. |
| c. | Terrain (emphasis on engagement area analysis). |
| | (1) Cover_____ Concealment_____. |
| | (2) Type of Soil_____ Remarks_____. |
| d. | Friendly Forces Encountered. |
| | (1) Size: Div__ Reg__ Bn__ Co__ Plt__ Sec__ Other_____. |
| | (2) Location (grid):_____. |
| | (3) USAF elements employed or encountered: Type____. |
| | (4) Effectiveness of air strikes and CAS (BDA): Damaged_____ Destroyed_____. |
| 2. | MISSION |
| a. | Mission completed as briefed? Yes__ No__ Comments_____. |
| b. | FRAGOs received: Yes__ No__ If yes, how many____ Effects/Comments_____. |

Figure C-7. Sample format for a company mission debrief

3. EXECUTION

a. Maneuver (General Overview)

(1) Routes: Enemy activity _____ Unsuspected hazards/problems _____.

(2) Control measures used: _____.

(3) Commo Check and T/O time: _____.

(4) LD time, Time on-station, Time return _____.

(5) Map corrections: _____.

b. Fires

(1) Number of Artillery missions called ___ Fired ___.

(2) Preplanned targets used: _____ On target: _____.

(3) Effectiveness: _____.

(4) Friendly ADA positions noted: _____.

(5) Comments: _____.

c. Flight Coordination

(1) Essential elements of information noted: _____.

(2) Friendly aircraft downed: Yes ___ No ___ If yes, location and reason _____.

(3) Crews recovered Yes ___ No ___ If no, probable pilot pickup point _____.

4. SERVICE SUPPORT

a. Status of FARPs in the area of operations, if known: Up ___ Down ___ Comment _____.

b. Hours flown: _____.

c. Class V consumed: .50cal ___ 30mm ___ 20mm ___
2.75 HE ___ MP5M ___ HELLFIRE ___ TOW ___

d. Aircraft status: Up ___ Down ___ Refueled ___ Comment _____.

e. Immediate Maintenance requirements: _____.

f. Crew status: Injuries _____
Endurance _____.

g. Location of injured crewmember(s) _____.

5. COMMAND AND SIGNAL

a. Chain of command (location) _____.

b. EW encountered _____.

c. Aircraft and crew _____.

d. Instructions for crew _____.

6. CONCLUSIONS AND RECOMMENDATIONS

Figure C-7. Sample format for a company mission debrief (concluded)

APPENDIX D

UNIT MOVEMENT

Before the ATKHB can mass its combat power rapidly at the decisive time and place on the battlefield, it must move there. Units that plan, train, and validate their movement plans greatly increase their chances of arriving in theater or on the battlefield ready to conduct combat operations. The more knowledgeable personnel are of movement plans and operations, the more efficient the move becomes. This appendix provides basic unit movement planning considerations and guidelines. Detailed unit movements information is found in the manuals referenced in paragraph D-10.

D-1. FUNDAMENTALS

a. An ATKHB begins training for its combat mission from the time the unit is activated. It deploys to a point where it can best accomplish the mission. Unit deployment training is necessary so the ATKHB can move in the most efficient manner. If it cannot move within its operational requirements, whether it deploys from CONUS or 30 kilometers from the battlefield, the success of the mission is jeopardized.

b. The ATKHB is only as effective as its logistics support. With the exception of the light infantry division ATKHB, equipment used to support and sustain the battalion is organic to the unit. To facilitate rapid response, effectiveness, and sustained operations, logistics support must be transported using the battalion's organic equipment. Therefore, units must be organized with the necessary assets, organic and external, to transport their logistics support in a single move.

c. ATKHBs must give careful consideration to prestocking shipping containers with aircraft components, common use class IX (air) and covers. This ensures that items are available and precludes delays in unit deployment. Units prepare and on/off-load aircraft and equipment; therefore, having the required ground-handling equipment, tie-down and palletizing materials on hand prior to deployment will save time. Fulfilling the requirement for tools and test equipment at the ports of embarkation and debarkation also results in more effective unit movements.

D-2. RESPONSIBILITIES

a. Commanders. Commanders are responsible for the movement of their unit personnel and equipment. They also--

- (1) Appoint a unit movement officer (and get him trained).
- (2) Supervise the operations of subordinate units.

FM 1-112

- (3) Establish policies for rail, air, and sea lines of communication.
- (4) Ensure compliance with directives, policies, and regulations.
- (5) Review and validate movement plans, SOPs, and load plans frequently.
- (6) Coordinate with other headquarters for technical data and logistics support.

b. Staffs. Staffs ensure compliance with the commander's directives and develop unit movement plans. They also--

- (1) Plan and supervise unit movement training.
- (2) Make recommendations for improvement to the commander.
- (3) Establish training programs for unit movement personnel.
- (4) Determine and coordinate logistics support requirements.
- (5) Ensure compliance with directives, policies, and regulations.
- (6) Ensure that subordinate unit movement plans, load plans, and SOPs are accurate and current.

c. Unit Movement Personnel. These personnel plan and conduct unit moves. They also--

- (1) Develop unit movement plans, SOPs, and load plans.
- (2) Conduct unit movement training.
- (3) Ensure that proper support and logistics requirements are requested.
- (4) Validate movement plans.
- (5) Inspect and inventory equipment before and after a unit movement.
- (6) Ensure proper preparation of personnel and equipment before a unit movement.

D-3. PLANNING AND PREPARATION

The ATKHB must plan and prepare to arrive at a designated location in the area of operations and begin battlefield missions. Modes of movement and deployment are

designated in orders. These orders are delivered in several formats such as an OPORD, a FRAGO, or a movement order. Because of the complexity of unit movements, the movement order is preferable. Movement orders provide detailed information such as transportation support, movement tables, and clearance numbers. The least preferred format is the FRAGO. The information below will assist planners in preparing movement directives and SOPs.

a. Movement Directive. The movement directive, published by DA, is the basic document that directs units to prepare to and move from home stations. The two types of moves are administrative and tactical. In an administrative move, enemy contact is not likely and units relocate to secure areas and/or ports of embarkation. The S4 has staff responsibility for administrative movements. A tactical move, however, requires a combat-ready posture and organization during all phases even though the purpose of the move is to relocate only. The S3 has staff responsibility for tactical moves. Movements are categorized as follows:

(1) **Category A.** A move from a home station with all the equipment authorized for that unit.

(2) **Category B.** A move from a home station with essential equipment only.

(3) **Category C.** A move from a home station with less than essential equipment. (The movement directive will specify what equipment to take.)

b. Movement Instructions. Movement instructions provide details for the execution of a movement. They are issued to implement the movement program and represent accepted procedures.

c. Movement Order. The movement order directs the movement of personnel and prescribed equipment from one location to another within a stated period.

d. Movement Plan. The movement plan provides up-to-date logistics data. These data reflect a summary of transportation requirements, priorities, and limiting factors incident to the movement of one or more units or special grouping of personnel by highway, marine, rail, or air transportation.

e. Load Plan. The load plan is a preplanned method for loading personnel and equipment for transport.

D-4. SELF-DEPLOYMENT

a. Because airlift and sealift assets are limited, selected ATKHBs (AH-64) should plan to self-deploy aircraft to the theater or area of operations. Apache aircraft

FM 1-112

must be equipped with the necessary auxiliary fuel, ALSE, and navigation and communication systems needed to conduct self-deployment operations prior to deployment.

b. Self-deployment may result in faster arrival in the area of operations, depending on the availability of strategic airlift assets. An advantage is eliminating the requirement for disassembly and reassembly. A major disadvantage is the high number of flight hours put on the aircraft getting to the theater/area of operations. Other considerations include maintenance impact, extended dispersal of aircraft along the deployment route due to maintenance, diplomatic clearances for overflight and landing, terrorist threat, and availability of support upon arrival at the theater/area of operations.

c. It must be recognized that the entire battalion can not self-deploy. The commander and staff must coordinate arrival of the rest of the battalion's personnel and equipment in the theater/area of operations by sea or air transportation, with the self-deployed aircraft and crews. References for planning self-deployments include FM 1-109, FM 1-111, and Planning Guide: Army Aviation Deployment for Contingency Operations, 1 February 1993.

D-5. AIRLIFT

a. An airlift is an operation executed according to prepared plans designed to ensure air transport of supplies, equipment, and personnel. The global nature of U.S. forces deployments requires that the ATKHB be able to package, document, on/off load, and tie-down equipment. Therefore, the ATKHB must be trained not only in mission accomplishment but also in the skills and execution of airlift deployment. Emergency situations require rapid response by the armed forces; air movement fulfills that requirement.

b. The air mobility command provides the strategic air assets necessary to move personnel and material during emergencies or for operational necessities. Although AMC aircraft are located around the world, they are limited in number and availability. Equipment accepted on AMC aircraft must be within specified space and weight limits. Table D-1 shows an airlift loading table.

c. The unit movement officer is the key to exercising the unit's air movement and loading plans. He supervises and conducts training and maintains updated movement data. Because operational requirements may exceed the airlift capacity, the unit movement officer also plans for the use of other types of transportation to conduct the air movement. Key references for unit air movement planning include FM 55-12, FM 55-9, TM 38-250, and Planning Guide: Army Aviation Deployment for Contingency Operations (see paragraph D-10 for complete titles).

Table D-1. Airlift loading table

| TYPE | MINIMUM DISASSEMBLY | | | C-5 ¹ | | | C-141 ¹ | | |
|--|---------------------|--------------|---------------|--------------------------------|--------------|---------------|--------------------------------|--------------|---------------|
| | | | | OPTIMUM TRANSPORT ² | | | OPTIMUM TRANSPORT ² | | |
| | N O | MAN HOURS | ET (HOURS) | N O | MAN HOURS | ET (HOURS) | N O | MAN HOURS | ET (HOURS) |
| AH-1 | 12 | 18 | 3 | 15 | 24 | 4 | 4 | .5 | .5 |
| UH-1 | 8 | 12 | 2 | 11 | 18 | 3 | 4 | .5 | .5 |
| OH-58C | 13 | 19.5 | 3.5 | 22 | 33 | 5.5 | 6 | 9 | 1.5 |
| | | | | | | | 8 | 12 | 2 |
| AH-64 ³ | 6 | 7 | 1 | 6 | 7 | 1 | 2 | 18 | 3 |
| UH-60 | 6 | 2 | .75 | 6 | 7 | 1 | 2 | 18 | 3 |
| OH-58D ³ | 12 | 18 | 3 | 22 | 36 | 6 | 8 | 15 | 2.5 |
| NOTES: | | | | | | | | | |
| 1. Numbers based on 6-man loading crews. | | | | | | | | | |
| 2. Number of aircraft that can be transported with further disassembly if flyaway conditions is not required on arrival. | | | | | | | | | |
| 3. Approximate figures. | | | | | | | | | |

d. Specific planning and support requirements for each unit vary. In an emergency, little time is available for planning. Therefore, the unit movement officer must identify requirements and develop and validate air movement plans to preclude difficulties during emergency deployments.

D-6. SEALIFT

Sealift deployment is normally used to move equipment and containerized material when response time for arriving in the theater/area of operations is not urgent, and/or equipment is too large or heavy for airlift. Although FSS and roll-on, roll-off are preferred, there are a variety of ships that may transport the unit's equipment. Therefore, planning and training may be limited to on-site surveys and data about the out-loading installation, ports of embarkation and debarkation and, to a limited extent, vessels that are likely to be employed. The deploying unit will have to prepare accurate cargo-loading movement data. However, higher headquarters should provide guidance and assistance in sealift planning. Key references for sealift include FM 55-30, FM 55-65, FM 55-312, AR 55-29, AR 55-113, AR 55-162, and Planning Guide: Army Aviation Deployment for Contingency Operations (see paragraph D-10 for complete titles).

D-7. RAIL MOVEMENT

a. Rail deployment of vehicles and equipment is normally selected when the distance to the SPOE or training site exceeds one day of ground convoy or when

FM 1-112

nonroadable plus other equipment exceeds 240 short tons. Rail shipment can damage sensitive aircraft components; therefore, aircraft are normally moved by airlift or sealift.

b. The division or installation transportation officer or DISCOM/COSCOM movement control officer can assist the movement officers with planning and identifying unit rail-loading requirements. He also should provide training material and current procedures for transporting equipment as well as other information to minimize planning time.

c. As with other forms of movement, the ATKHB is responsible for internal administration and preparation of unit assets for rail movement. Plans and SOPs will address all rail requirements such as loading, tie-downs, organization, and specific safety provisions. Rail movement plans are completed as required by the controlling transportation agency.

d. Key references for rail movement include FM 55-15, FM 55-65, TM 55-208, TM 55-625, TM 55-2200-001-12, and Planning Guide: Army Aviation Deployment for Contingency Operations (see paragraph D-10 for complete titles).

D-8. GROUND CONVOY MOVEMENT

a. Types. The movement of troops from one location to another is inherent in any phase of a military operation. A common form of troop movement is the ground convoy or road march. Road marches may be tactical or administrative, depending on the enemy situation.

(1) Tactical movement. When contact with the enemy is possible, a unit will conduct a tactical movement. For example, if troops move forward to participate in combat operations, the movement is tactical. The S3 plans tactical movements.

(2) Administrative movement. If contact with the enemy is unlikely, a unit will conduct a nontactical movement. Movement in the communications zone to reposition laterally or to ease future operations is administrative. The S4 is normally responsible for planning administrative moves.

b. References. The same references listed in paragraph D-6 apply to ground convoy movements. FM 55-312 and Planning Guide: Army Aviation Deployment for Contingency Operations are key references for unit movement officers and convoy commanders.

c. Organization.

(1) March columns are organized to maintain unit integrity. In a tactical march column, all elements use the same route for a single movement and are under the control of a single commander. A large column may be composed of a number of subdivisions.

(a) **Serial.** A serial is a major subdivision of a march column. For purposes of planning, regulation, and control, it is organized as a single unit under one commander. An ATKHB is usually one serial.

(b) **March unit.** A march unit is a subdivision of a serial and is normally a squad, section, platoon, or company. It moves and halts under the control of a single commander, using oral and visual signals. A radio is used only when no other means of communication can be used. March units of the main body are composed of individual units, any attachments, the battalion main CP, and the battalion trains. POL vehicles required for refueling during nontactical marches may move ahead of schedule to establish a forward refueling point.

(2) March columns, regardless of size, are composed of four elements. These elements are the reconnaissance party, the quartering party, the main body, and the trail party. Figure D-1 shows the organization of a battalion tactical road march.

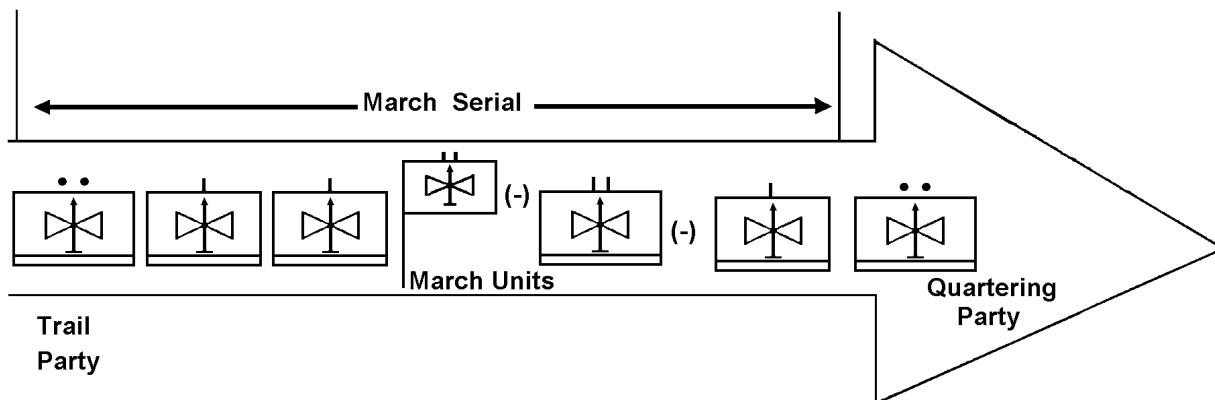

Figure D-1. Organization of a tactical road march

d. **Planning Process.**

(1) Tactical road marches require extensive planning. Commanders and staffs use the estimate process to determine how to best execute a move from one point to another. Road-march planning consists of three concurrent steps. These steps are to determine requirements for the move, analyze organic and nonorganic movement capabilities, and establish unit movement priorities. During movement planning, the battalion commander and staff must consider the--

(a) Enemy situation and capabilities, terrain conditions, and weather.

FM 1-112

(b) Organization of the ATKHB.

(c) Security measures to be taken before the movement, during movement, and at the destination.

(d) Assembly of the march units.

(e) Loading of personnel and equipment.

(f) Actions at the destination.

(2) When the ATKHB prepares for a tactical road march, the sequence of planning for the march (if time permits) is--

(a) Prepare and issue a warning order as early as possible to allow subordinates time to prepare for the march.

(b) Prepare an estimate of the situation, analyze routes designated by the brigade, and specify the organization of the march serial.

(c) Prepare and issue the march order.

(d) Prepare detailed movement plans and assembly area plans.

(e) Organize and dispatch reconnaissance and quartering parties as required.

e. **Planning Factors.** Planners apply movement formulas to known distance, rate, and time data to derive information necessary to prepare a time schedule. The time schedule requires departures and arrivals of march elements.

(1) **Time and distance relationships.** Relationships between time and distance are the basis for march planning. Planners determine how far the column is to travel (distance) and how long it will take to make the move (time). They must also know how much space (length of column) the column will occupy on the route and the distance (road gap) or time (time gap) that separates march columns and their elements. Each term used for distance has a corresponding term for time. The length of a column in kilometers has an equivalent pass time in minutes; the road distance in kilometers or miles has a corresponding time distance. Relationships between time and distance in the average rate of march are shown in Figure D-2.

(2) **Distance factors.** Distance factors include vehicle interval, column gap, traffic density, column length, and road gap. *Vehicle interval* is the distance between two consecutive vehicles of an organized element of a column. *Column gap* is the space

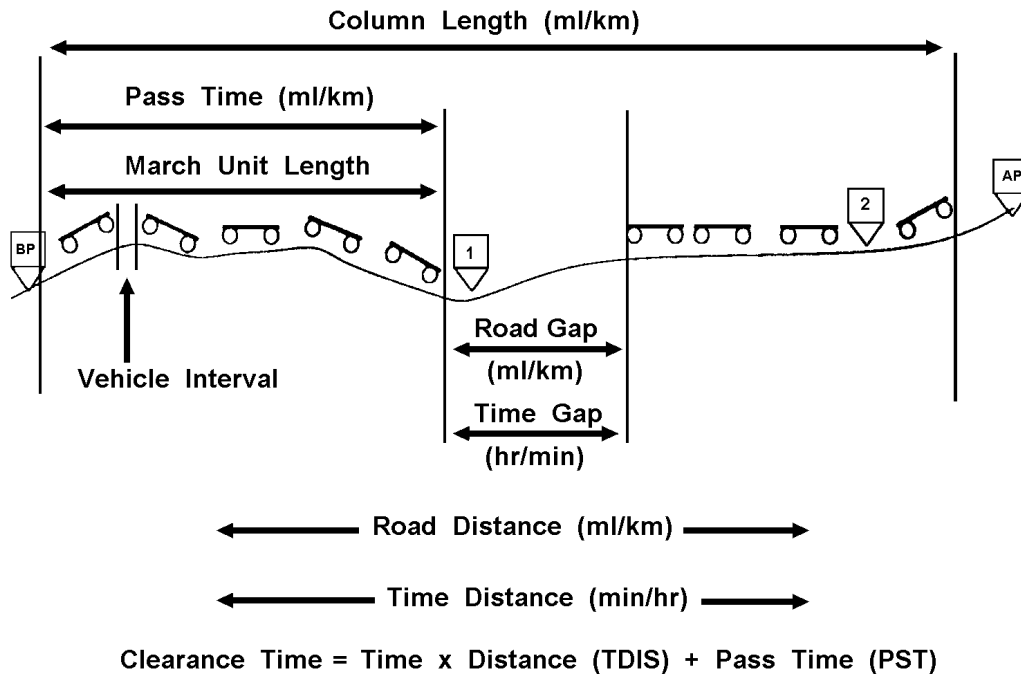

Figure D-2. Time and distance relationships

between two organized elements following each other on the same route. It can be calculated in units of length (road gap) or in units of time (time gap) as measured from the rear of the leading element to the front of the following element. *Traffic density* is the average number of vehicles that occupy 1 mile or 1 kilometer of road space, expressed in vehicles per mile or vehicles per kilometer. *Column length* is the length of roadway occupied by a column, including gaps in the column measured from the first vehicle to the last vehicle. *Road gap* is the distance between two march elements. It is the length aspect of the column gap. Since a road gap is more significant when the column is moving than when the column is halted, it becomes a factor of time rather than distance.

(3) Rate factors. Speed, pace, and rate of march are rate factors. *Speed* is the velocity of a vehicle at a given moment as shown on the speedometer (in kmph or mph). *Pace* is the regulated speed of a column or element. It is set by the lead vehicle or an individual in the lead element to maintain the prescribed average speed. *Rate of march* is the average number of miles or kilometers traveled in any given period. It includes short periodic halts and other short delays. The rate of march is expressed as miles or kilometers traveled in an hour.

(4) Time factors. Time factors include arrival time, clearance time, completion time, and pass time. Others are EXTAL, time-distance, road clearance time, and time gap.

FM 1-112

(a) *Arrival time* is the moment when the head of the column arrives at a designated point or line. *Clearance time* is the moment when the head of the column arrives at a designated point or line. *Completion time* is the moment when the tail of a column passes the release point. *Pass time* is the time between the moment the first element of a column passes a given point and the moment the last element passes the same point.

(b) *Extra time* is when the allowance of one minute per 25 vehicles is always allotted above the calculated pass time within a motor march column moving under one identification serial number. For a column that has more than 600 vehicles, the EXTAL is two minutes per 25 vehicles. If a column has less than 25 vehicles, no extra time is allotted. An EXTAL is equitably added to march unit pass time within a serial.

(c) *Time-distance* is the time required to move from one point to another at a given rate of march. Time-distance normally represents the movement of the head of the column from the start point to the release point.

(d) *Road clearance time* is the total time a column requires to travel over and clear a section of road. Road clearance time equals time distance plus column pass time.

(e) *Time gap* is the time measured between the rear and front of successive elements as they move past any given point. Time gap is the time aspect of column gap and may also be the conversion of road gap to time. There are no prescribed standard gaps. Gaps depend on the size of serials and march units, the time available for the movement, and the tactics required for protection against air and ground attack.

f. Movement Formula Application.

This paragraph implements portions of STANAG 2041.

(1) Distance, rate, and time are the basic factors for movement computations. If the march planner knows two of these factors, he can easily determine the third by dividing or multiplying one by the other. The movement formulas are as follows:

(a) Rate is determined by dividing distance by time.

$$\text{RATE} = \frac{\text{DISTANCE}}{\text{TIME}}$$

(b) Distance is determine by multiplying rate by time.

$$\text{DISTANCE} = \text{RATE} \times \text{TIME}$$

(c) Time is determine by dividing distance by rate.

$$\text{TIME} = \frac{\text{DISTANCE}}{\text{RATE}}$$

(2) The march planner must determine time-distance, pass time, arrival time, and completion time. The procedures for determining these factors are given below.

(a) **TDIS.** TDIS is determined by dividing distance to be traveled by rate of march (Figure D-3). TDIS does not include time for long delays or extended scheduled halts. A time-distance table (Table D-2) is a valuable tool to the march planner. It provides a listing of factors used to calculate the time required to travel certain distances at specified speeds. Travel rates are expressed in speeds and corresponding rates of march. Travel factors are derived from rate of march, which includes time for short, periodic halts and other minor delays that might occur.

| |
|---|
| $\text{TDIS} = \frac{\text{DISTANCE (miles or km)}}{\text{RATE OF MARCH (mih or kmih)}}$ |
| <p>EXAMPLE: Determine TDIS of a serial traveling 135 kilometers at a speed of 24 kmph (rate of march 20 kmih)</p> |
| $\text{TDIS} = \frac{135 \text{ (km)}}{20 \text{ kmih}} = 6.75 \text{ hours}$ |
| $\begin{array}{r} 0.75 \text{ (fraction)} \\ \underline{\times 60 \text{ (minutes)}} \\ 45 .00 \text{ (minutes)} \end{array}$ |
| <p>TDIS = 6 hours and 45 minutes</p> |

Figure D-3. TDIS formula

Table D-2. TDIS table

| SPEED (miles/kmph) | RATE OF MARCH (miles/kmph) | MINUTES TO TRAVEL 1 KILOMETER | MINUTES TO TRAVEL 1 MILE |
|-----------------------|-------------------------------|-------------------------------------|--------------------------------|
| 10 mph 16 kmph | 8 mih 12 kmih | 5 | 7.5 |
| 15 mph 24 kmph | 12 mih 20 kmih | 3 | 5 |
| 20 mph 32 kmph | 16 mih 25 kmih | 2.4 | 3.75 |
| 25 mph 40 kmph | 20 mih 32 kmih | 1.84 | 3 |
| 30 mph 48 kmph | 25 mih 40 kmih | 1.5 | 2.4 |
| 35 mph 56 kmph | 30 mih 46 kmih | 1.3 | 2 |
| 40 mph 65 kmph | 33 mih 53 kmih | 1.13 | 1.8 |

(b) **Pass time.** Pass time for a serial is determined by adding march unit pass times together, including time gaps between march units (Figure D-4).

| |
|--|
| <p>$PST = \frac{NO\ OF\ VEH \times 60}{DENSITY \times SPEED} + \frac{NO.\ OF\ VEH}{25} = TIME\ GAPS\ (Min)$</p> <p>EXAMPLE: Determine PST of a serial of 150 vehicles organized into 6 march units of 25 vehicles each, traveling at a speed of 24 kmph, with a density of 15 VPK, and using a 2-minute time gap between march units.</p> <p>$PST = \frac{150 \times 60}{15 \times 24} + \frac{150}{25} + (2 \times 6) = \frac{9,000}{360} + 6 + 10 = 25 + 6 + 10$</p> <p style="text-align: center;">PST = 41 minutes</p> <p>NOTES 1. Round off fractions of minutes to next higher minute.</p> <p>2. EXTAL is allocated on the basis of 1 minute per 25 vehicles added to serial pass time. EXTAL is equitably added to pass time of each march unit in the serial.</p> |
|--|

Figure D-4. Pass time formula

(c) **Arrival time.** In march planning, the release point is normally designated as the terminal point of movement. Arrival time at the release point is determined by adding time-distance and any scheduled halts to the start-point time (Figure D-5).

| | HOURS | MINUTES |
|----------------------------|-----------|-----------|
| SP TIME | 08 | 00 |
| TIME-DISTANCE | 06 | 45 |
| SCHEDULED HALT | <u>01</u> | <u>00</u> |
| | 15 | 45 |
| ARRIVAL TIME IS 1545 HOURS | | |

Figure D-5. Arrival time formula

(d) **Completion time.** Completion time is calculated by adding pass time to the arrival time or by adding to the start-point time the distance, pass time, and any scheduled halts.

g. March Order.

(1) The march order format is the same for tactical and nontactical movements. The march order is prepared either as an annex to an OPORD, a separate OPORD, or a FRAGO. Figure D-6 shows an example of an OPORD for a road march.

(2) The march order should include, as a minimum, a strip map. A strip map is a sketch of the route of march. It is normally included as an annex to the march order. Figure D-7 shows an example of a strip map. The amount of detail on the strip map depends on its intended purpose and the unit level at which it is prepared. The map should identify critical points, start-point and release-point times and locations, order of march, maximum catch-up speed, distances to be maintained between vehicles and units, assembly area locations, and instructions on future operations. In designating distance (interval) or density, the planner must know its effect on column length and the time required to move.

FM 1-112

Copy no of Copies
112th ATKHB
GAY (GL645745)
211600Z Aug 19xx
EEL

OPORD 31

Reference: Map, JOG, NH 16-2, 1:250,000, 1st Edition.

Time Zone Used Throughout the Order: ZULU

Task Organization: Annex B (Road Movement Table).

1. SITUATION.
 - a. Enemy Forces. Current INTSUM.
 - b. Friendly Forces. Aviation Brigade moves 221000 Aug to assembly area vicinity FRAGO (GN7512).
 - c. Attachments and Detachments. 2/B/31st AD and 1/A/52d Engr attached effective 220430 Aug.
2. MISSION. 1-112th ATKHB moves to assembly area vicinity FARGO (GN7512); SP (GL6672) 221159 Aug; closes on the assembly area by 221930 Aug.
3. EXECUTION.
 - a. Concept of Operation. Annex A (Route Overlay). I intend to close assembly area during daylight. BN conducts a motor march, in six march units via Route RED, first march unit crossing SP at 221159 Aug and last march unit clearing the release point, vicinity FARGO, by 221830 Aug.
 - d. March Unit 3:
 - e. March Unit 4:
 - f. March Unit 5:
 - g. March Unit 6:
 - h. Coordinating Instructions.
 - (1) Annex B (Road Movement Table).
 - (2) Quartering party assemble at Main CP at 220900 Aug.
 - (3) Vehicle density: open column; 12 vehicles per kilometer.
 - (4) Rate of march: 24 kmph.
 - (5) Time gap: Five minutes between march units.
 - (6) Vehicle bumper markings will be covered.
4. SERVICE SUPPORT.
 - a. Supply. Each man draw two MREs at breakfast for noon and evening meals on 22 Aug.
 - b. Services. Trail party task force control.
5. COMMAND AND SIGNAL.
 - a. Command.
 - (1) Chain of command.
 - (2) Location of convoy commander.
 - (3) Succession of command.
 - b. Signal.
 - (1) SOI in effect.
 - (2) Convoy frequency, BN CMD frequency.
 - (3) Communication check procedures.
 - (4) Lost communications procedures.
 - (5) Code words or passwords.

Figure D-6. Sample format, road movement order

Annex A (Strip Map) to OPORD 10-112 ATKHB

Reference: Map, series M1988,
 Sheet MM 55-0 (Lich en Bier)
 Edition II, 1:250,000
 Time zone used throughout order: Zulu

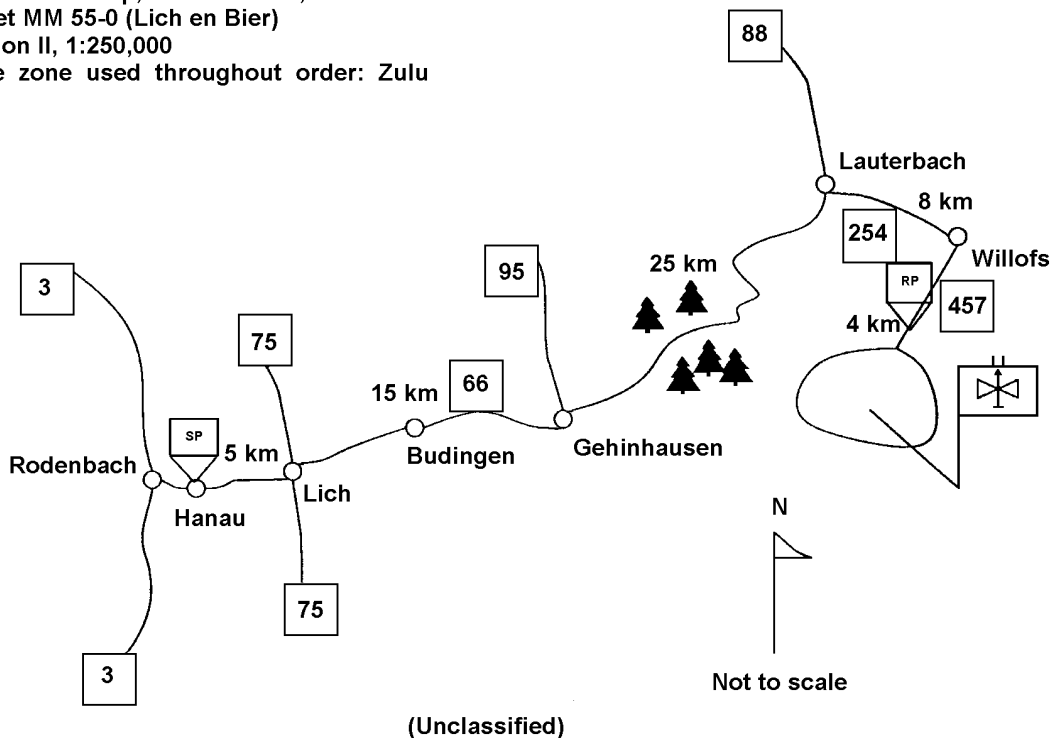

Figure D-7. Sample strip map

(3) The march order also contains a statement of the enemy situation, the weather, and visibility conditions. It should also contain (if applicable)--

- (a)** Road restrictions and information derived from route reconnaissance.
- (b)** Actions on enemy contact (ground and air).
- (c)** Actions at halts and actions for disabled vehicles.
- (d)** Actions in the assembly area.
- (e)** Procedures for resupply, maintenance, and feeding.
- (f)** Location of leaders and a communications plan.

(4) Much of the information needed to conduct the march should be in the unit SOP. Only exceptions to the SOP should be stated in the march order.

h. Road Movement Table.

(1) A road movement table is normally an annex to a movement order as shown in Figure D-8. It is a convenient means of transmitting to subordinate units time schedules and other essential details of the move. It is particularly useful when the inclusion of such details in the operation order would make the order complicated or unduly long. Road movement tables consist of two parts. The first part contains data paragraphs that reflect information common to two or more march elements. The second part contains a list of serials or march units along with all other necessary information arranged in tabular form.

| (Classification) | |
|---|---|
| Annex B (Road Movement Table) to OPORD 31 | |
| Reference: Map, JOG, NH 16-2, 1:250,000, 1st Edition. | |
| Time Zone Used Throughout the Order: Zulu. | |
| General Data: | |
| 1. | Average Speed: 24 kilometers per hour. |
| 2. | Traffic Density: 12 vehicles per hour. |
| 3. | Halts: 1545-1645, meal and fuel; all others SOP. |
| 4. | Critical Points: Route RED. a. Start point: BOLL WEEVIL (GL6672). b. Release point: FRAGO (GN7512). c. Other critical points: COLUMBIA (GL6979), DURHAM (GL6989), NIAGARA (GL6893), and BOSTON (GN7106). |
| | d. Route Classification: 10X50. e. Route Restriction: None. |
| 5. | Main Routes to Start Point: NA. |
| 6. | Main Routes to Release Point: NA. |

Figure D-8. Sample format for a road movement table

(2) The march planner must know the times at which serials and march units arrive at and clear critical points. Other information in the road movement table includes serial or march unit number, date of move, units involved, number of vehicles, and load class of the heaviest vehicle to be used. A remarks section should reflect any details not covered elsewhere.

i. March Procedures.

(1) Reconnaissance party. An ATKHB, augmented by engineer and other CS assets, conducts a route reconnaissance to determine travel time, capacities of overpasses and bridges, height of underpasses and tunnels, and locations of ferries and fords. The aeroscout platoon also identifies critical points, including choke points and obstacles. Route reconnaissance confirms and supplements data from map studies, higher headquarters, and air reconnaissance. Instructions to the aeroscout platoon should include the nature and extent of the required information and the time and place the report is to be submitted.

(2) Quarterming party. The ATKHB quarterming party consists of the quarterming parties of each of the companies. The commander dispatches a quarterming party to reconnoiter the new area and guide march elements into position.

(3) Main body.

(a) Before starting a march, each march unit of a serial reconnoiters its route to the start point and determines the exact time required to reach it. The movement order states the time that the serial will arrive at and clear its start point. The serial commander then determines and announces the times for march units of his serial to arrive at and clear the start point. Arrival time at the start point is critical. Each march unit must arrive at and clear the start point on time; otherwise, movement of other elements may be delayed.

(b) During the movement, march units move at the constant speed designated in the order, maintaining proper interval and column gap. Elements in a column of any length may simultaneously encounter many different types of routes and obstacles. As a result, different parts of the column may move at different speeds at the same time. This can produce an undesirable accordion-like action or "whip effect." The movement order gives march speed, rate of march, and maximum catch-up speed to ensure safety and to reduce column whipping. March units report crossing each control point as directed by the march order. During the move, air and ground security are maintained.

(4) Trail party. The trail party is normally made up of elements of the HHC motor maintenance section and is the last unit in a task force serial. The trail party is led by the battalion movement officer. Its function is to recover disabled vehicles. If a vehicle cannot be repaired or towed, the vehicle and its crew are moved off the road into a secure area. Crew members are given sufficient food and water and left with the vehicle. When vehicles are left behind, the BMO reports their locations and the reason they were left behind to the task force S4. Once the trail party completes the road march, maintenance priority becomes recovery of disabled vehicles. A tactical road march is not complete until all march units and vehicles arrive at their destination.

j. March Techniques.

(1) **Close column.** In a close column, vehicles are spaced about 20 to 25 meters apart during daylight hours. At night, vehicles are spaced so that each driver can see the two lights in the blackout marker of the vehicle ahead. A close column is normally used for marches during the hours of darkness under blackout driving conditions. This method of marching takes maximum advantage of the traffic capacity of the route but provides little dispersion. Normally, vehicle density is about 30 vehicles per kilometer along the route.

(2) **Open column.** In an open column, the distance between vehicles is increased to provide greater dispersion. The distance between vehicles varies from 50 to 100 meters, but may be greater if required. An open column is normally used during daylight. It may also be used at night using infrared lights, blackout lights, or passive night-vision equipment. Vehicle density varies from 10 to 15 vehicles per kilometer.

(3) **Infiltration.** During a move by infiltration, vehicles are dispatched individually, in small groups, or at irregular intervals at a rate that will keep the traffic density down and prevent undue massing of vehicles. Infiltration provides the best possible passive defense against enemy observation and attack. It is suited for tactical marches when sufficient time and road space are available and when maximum security, deception, and dispersion are desired.

k. Control Measures.

(1) **Critical point.** Critical points on a route are those points used for reference in providing instructions, places where interference with movement might occur, or places where timing might be a critical factor. The route reconnaissance report or a map study should provide the march planner with information to designate critical points along the route of march and distances from one critical point to another. At designated critical points, guides or signs may be used to ensure the smooth flow of traffic. The convoy commander may want to be present at the passing of some critical points. The start point and release point are two critical points that are always designated. Using the checkpoint symbol, critical points are designated by number, letter, or code word. The march planner must ensure that designations for critical points do not conflict with those of checkpoints.

(2) **Start point.** SPs provide all units of a march column a common point for starting their movement. When units use more than one route, each route has a start point. The SP is a place along the route of march that is easily recognizable on the map and on the ground such as a road intersection. An SP should be far enough from assembly areas to allow units to organize and move at the prescribed speed and interval when they reach the SP. No element of a march column should be required to march to the rear or through another unit to reach the SP.

(3) **RP.** RPs provide all units of the march column a common point at which to reestablish control of their parent unit. The RP should be on the route of march and easily recognizable on the map and on the ground. Units do not stay at the release point. Guides meet units as they arrive at the release point and lead them to the assembly area. Multiple routes and cross-country movement from the release point to assembly areas enable units to disperse rapidly. No unit should be required to counter-march or pass through another unit to reach its new position.

(4) **Strip map.** Copies of the strip map should be reproduced and distributed to all key personnel. The strip map should contain the start point and RP, restrictions, and critical points and the distances between them.

I. Security.

(1) During the march, units maintain security through observation, weapons orientation, dispersion, and camouflage. Commanders assign sectors of observation to their personnel that will give them a 360-degree observation. Weapons are oriented on specific sectors throughout the column. The lead elements cover the front, following elements cover alternate flanks, and the trail element covers the rear. Security is also maintained during halts.

(a) Scheduled halts are planned along the march route for maintenance and rest or to follow higher level movement orders. At scheduled halts, vehicles and soldiers move to the side of the road while maintaining march dispersion. Local security is set up immediately, and drivers perform operational maintenance checks. However, the unit is ready to move at a moment's notice.

(b) Unscheduled halts and actions may be caused by unforeseen developments such as obstacles, traffic congestion, or equipment failure. If a halt is necessary, the march column's first priority is to establish security. Each unit forms a hasty perimeter defense.

(2) To minimize the ATKHB's vulnerability to enemy air attack, AD must be planned and AD security measures implemented. The convoy commander must effectively integrate his ADA assets into his fire plans and ensure that all passive and active AD measures implemented at company level are planned and used.

(3) Each vehicle in a motor march has an air guard to provide air security. However, specific vehicles may be designated as air guard vehicles to conduct air rather than ground observation.

(4) Obstacles that are reported by an aeroscout platoon should be bypassed if possible. If obstacles cannot be bypassed, the lead march unit goes into a hasty defense to cover and overwatch. If engineers are available to assist, the lead march unit can

breach the obstacle. As the lead march unit breaches the obstacle, the other march units move at decreased speed or move off the road and monitor the battalion command net.

(5) If the task force comes under attack by enemy indirect fire during the road march, the unit in contact continues to move. The remainder of the task force attempts to bypass the impact area (Figure D-9).

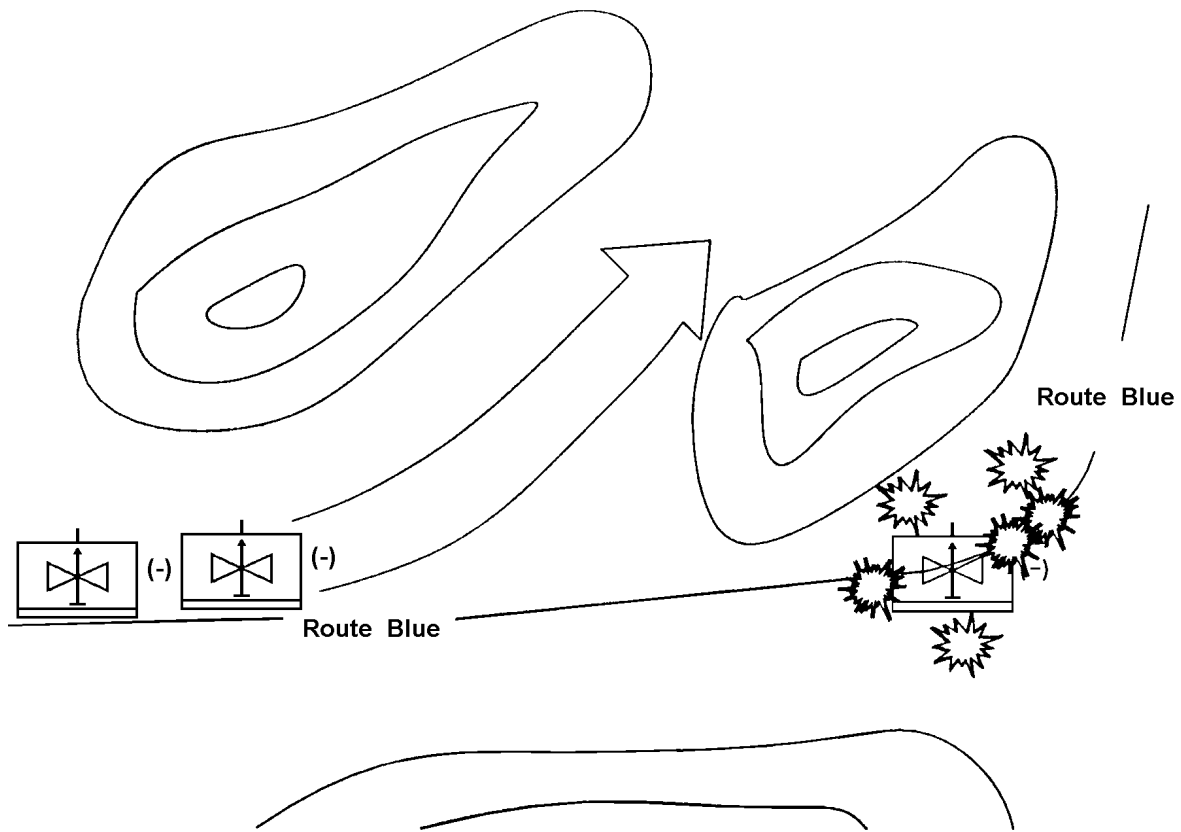

Figure D-9. Actions under indirect fire

(6) If the task force is attacked by hostile aircraft during the march, the march unit that is attacked moves off the road into a quick defensive posture and immediately engages the aircraft with all available automatic weapons. The rest of the convoy moves to covered and concealed areas until the engagement stops.

(7) Ambushes are fought without delay. If the convoy is ambushed, the march unit in the KZ increases its speed, fights through, and reports the ambush.

(8) Disabled vehicles must not obstruct traffic; they are moved off the road and their status is reported immediately. Security is established and guides are posted to direct traffic. If the operator repairs the vehicle, he rejoins the rear of the column. If the operator cannot repair the vehicle, trail party maintenance elements recover it.

(9) Messengers and visual signals are the preferred means of communication during road marches. Because the enemy has radio direction-finding equipment, the radio is used only in emergencies and when no other means of communication can be used. Road guides can also be used to pass messages from one march unit to a following march unit. Because of the need for radio silence, road guides are used to control the speed of march units and the intervals between them.

(10) Restrictions are points along the route of march where movement may be hindered or obstructed. These points can include bridges, intersections, ferries, and bypasses. The march planner should stagger start times, adjust speeds to allow for restrictions, or plan to halt the column en route until the restriction is passed.

(11) Units must be able to operate under limited visibility conditions caused by darkness, smoke, dust, fog, heavy rain, or heavy snow. Limited visibility decreases the speed of movement and increases difficulties in navigation, recognizing checkpoints, and maintaining proper interval between units. To overcome C² problems caused by limited visibility, convoy commanders may position themselves just behind lead elements. More restrictive control measures, such as additional checkpoints, phase lines, and use of a single route, may become necessary.

(12) The convoy commander also plans for an NBC attack. He--

(a) Ensures that protective and decontamination materials are properly distributed and their location known to the entire march unit.

(b) Ensures that the proper MOPP level is maintained, based on the threat and the temperature level. Personnel may start out in MOPP 3 to avoid having to stop to change into MOPP 3 or MOPP 4.

(c) Ensures that chemically or biologically contaminated areas are avoided if possible. If contaminated areas must be crossed, personnel--

- Use MOPP 4.
- Cover as much equipment as possible.
- Avoid moving through underbrush.

FM 1-112

- Stay on hard-surfaced roads.
- Avoid low areas.
- Avoid moving early or late in the day.
- Stagger vehicles in the column.
- Decrease speed to reduce dust or mud.
- Increase vehicle interval.
- Scrape the surfaces of dirt roads to clear them of contamination.

(d) Avoids nuclear contaminated areas, if possible. If nuclear contaminated areas must be crossed, personnel--

- Wear regular wet-weather gear with a scarf or handkerchief over the nose and mouth.
- Avoid stirring up dust as much as possible.
- Ensure that the IM174 radiac meter is used.
- Wash hard-top roads before traveling over them.
- Wet dirt roads to minimize fallout dust.

D-9. TRAINING

There are several specialized training courses that UMOs and UMNCOs should attend. Commanders/staff officers must ensure that UMOs and UMNCOs have the opportunity to attend all available movements related training possible. An untrained UMO/UMNCO will likely translate into uncoordinated and ineffective unit movements and deployments.

a. Hazardous cargo will be packaged and shipped according to TM 38-250. The Military Packaging Center, Aberdeen Proving Grounds, Maryland, offers the two-week Defense Packaging of Hazardous Materials for Transportation Course (Course #: 8B-F7(JT)). The course trains soldiers to prepare hazardous cargo for transport. Additionally, once certified, personnel must attend the one-week Defense (Refresher) Packaging of Hazardous Materials for Transportation Course (Course #: 8B-F35(JT)) every two years. Instruction is provided by mobile training teams at most installations. More information about the courses may be obtained from the Military Packaging Center, DSN: 298-5185.

b. UMOs/UMNCOs should also attend the US Air Force's AMC Airload Planner Course, which trains unit movement officers to plan movements using Air Force assets.

c. Finally, units should research the availability of unit movements officers classes at corps or division level. Additional movement training is listed in AR 351-1. Commanders should ensure that their UMOs attend as many courses as possible.

D-10. UNIT MOVEMENTS REFERENCES

At a minimum, UMOs should maintain current/updated copies of the following references for unit movements planning and execution.

Joint Publications

Joint Pub 4-01.3. Joint Tactics, Techniques, and Procedures for Movement Control. 26 January 1994.

Army Field Manuals

FM 1-109. Aviation Self-Deployment Planning. 29 May 1987.

FM 1-111. Aviation Brigades. 27 August 1990.

FM 55-9. Unit Air Movement Planning. 5 April 1993.

FM 55-12. Movement of Units in Air Force Aircraft. 10 November 1989.

FM 55-15. Transportation Reference Data. 9 June 1986.

FM 55-30. Army Motor Transport Units and Operations. 14 March 1980.

FM 55-65. Strategic Deployment. 3 October 1995.

FM 55-312. Military Convoy Operations in the Continental United States. 3 April 1991.

Technical Manuals

TM 38-250. Preparing of Hazardous Materials for Military Air Shipment. 25 November 1994.

TM 55-208. Railway Equipment Characteristics and Data. 5 Oct 76.

TM 55-625. Transportability Criteria and Guidance for Loading and Unloading Multilevel Railcars at Military Installations in the United States. 15 August 1970.

TM 55-2200-001-12. Transportability Guidance for Application of Blocking, Bracing, and Tiedown Materiels for Rail Transport. 31 May 1978.

Army Regulations

AR 55-29. Military Convoy Operations in CONUS. 3 September 1971.

AR-55-113. Movement of Units Within Continental United States. 19 July 1973.

AR 55-162. Permits for Oversize, Overweight, or Other special Military Movement on Public Highways in the United States. 1 January 1979.

Other References

FM 1-112

Planning Guide: Army Aviation Deployment for Contingency Operations. 1 February 1993.

FM 1-564. Shipboard Operations. Projected publication date: January 1997.

APPENDIX E

TACTICAL STANDING OPERATING PROCEDURES

E-1. GENERAL

This appendix is written as an outline for a unit to follow when writing a tactical SOP. Details discussing exact procedures have been intentionally omitted so the commander can formulate his SOP.

a. Formats. Several formats are used throughout the aviation community when writing Tactical SOPs. The format below follows the five paragraph operations order, inserting SOP recommendations where appropriate. The goal of this technique is that in an OPORD, when it states "Per SOP", the soldier can logically turn to the same location in the SOP and find the information.

b. Recommendations. Everyone in the battalion will be using the SOP, from the soldier working in the motor pool to the battalion commander. Write the SOP so that every soldier can understand the sections he is concerned with. When possible, use diagrams (a picture is worth a thousand words). Leave areas within the SOP blank so that individuals can put personal notes or changes close to the appropriate area. The SOP should be sized to fit in either a BDU or flight suit pocket. Finally, keep it functional, not flashy. Substance is much more important than pretty pictures throughout.

E-2. SOP FORMAT

a. Errata Page. Inserted at the beginning of the document, this page is used to mark when and where minor changes are to be inserted in the SOP.

b. Purpose Memorandum. After the errata page, a memorandum from the battalion commander giving the purpose of the SOP, its scope, and how updates/changes to the SOP should be added. The commander's philosophy, the unit METL, and the commander's intent for conducting combat operations should also be placed here.

c. Table of Contents. The table of contents should be an outline of the SOP. In this case, paragraphs and subparagraph headings of the unit operations order format are used. The table of contents should be detailed to the point that it becomes the unit standard for all written or verbal operations orders.

d. Staff Responsibilities. An outline, in bullet form, explaining the principle duties of each staff member during operations. This should nearly be complete enough from which to write an evaluation support form.

FM 1-112

e. Troop Leading Procedures. Include a checklist for unit leaders to use when initiating the orders process.

f. Operations Order Background.

(1) References. Division, Brigade, TF SOPs, and their dates.

(2) Time zone. Time zone used throughout the order.

(3) Task Organization. Configuration of the unit in the field and how the subordinate units are designed to accomplish the METL.

g. Figure E-1 is a sample format for a TAC SOP.

| |
|--|
| <p>1. SITUATION</p> <p>a. <u>Enemy Forces.</u> If the battalion has defined contingency regions, include key elements of expected enemy unit organization diagrams, doctrine, tactics, and equipment.</p> <p>b. <u>Friendly Forces.</u> Include expected habitual relationships in the theater of operations, and habitual relationships used frequently for training.</p> <p>c. <u>Attachments/Detachments.</u> If the battalion has any habitual relationship (such as a team of AD from the divisional ADA battalion) subordinate units, their structure should be listed here. For nonhabitual, OPCON/attached units, a single card that fits on a kneeboard should be developed to provide crew members with a quick reference aid.</p> <p>d. <u>Weather.</u> What are the weather minimums for battalion operations? What are the procedures for disseminating weather to the companies? In what format should the S-2 distribute the weather?</p> <p>2. MISSION. List the METL to focus training.</p> <p>3. EXECUTION. Show an example or list of standardized graphics and graphics names (for operations overlays), consistent with FM 101-5-1.</p> <p>a. Concept of the Operation.</p> <p>(1) Commander's intent.</p> <p>(2) Scheme of maneuver.</p> <p>(a) Ground.</p> |
|--|

Figure E-1. Sample format for a TAC SOP

- Tactical road march procedures.
- Quarters party procedures.
- Assembly area procedures. Include bugout/ERP procedures for both aircraft and ground vehicles.

(b) Air.

- Define REDCON status.
- Explain radio check procedures.
- Lineup/takeoff procedures.
- Common formations.
- Company-to-company battle handover checklist.
- Company-to-company target handover.
- HA procedures.
- BP procedures.
- Target and engagement priorities.
- Fire distribution procedures.
- Laser codes.

(c) Deep operations.

(d) JAAT operations. Include JAAT brief format(s), etc.

(3) Tasks to subordinate units. Include any operations (quarters party, etc.) that fall to the same unit every time they are executed.

(4) FS.

(a) Firing units.

(b) Target priorities.

(c) Target attack criteria.

(d) Target reference points. Address reserved TRPs.

Figure E-1. Sample format for a TAC SOP (continued)

- (e) CAS.
 - (f) SEAD operations.
- (5) ADA
- (6) EW/ECM
- (7) Obstacles
- (8) Deception operations
- (9) A²C²
 - (a) Air routes/corridors, ACPs.
 - (b) Coordinating altitude. Minimum safe altitude, SAAFR, MRRs.
- (10) NBC operations.
 - (a) NBC status.
 - (b) Decontamination operations. Procedures for the conduct of decontamination sites for the decontamination teams, and the flight teams/ sections.
 - (c) In-flight masking/unmasking procedures.
- b. Air Mission Instructions.
 - (1) Order of movement.
 - (2) Lighting requirements.
 - (3) Special mission equipment.
 - (4) IMC breakup procedures.
 - (5) IMC recovery airfield.
- c. Coordinating Instructions.
 - (1) EEFI.
 - (2) PIR.

Figure E-1. Sample format for a TAC SOP (continued)

- (3)** MOPP level.
 - (4)** Times.
 - (a)** Inspections.
 - (b)** Rehearsals.
 - (c)** Preflight.
 - (d)** Crank time.
 - (e)** Communications check.
 - (f)** Lineup.
 - (g)** Takeoff.
 - (h)** SP.
 - (i)** Passage point (ingress).
 - (j)** Time on target.
 - (k)** Relief on station.
 - (l)** Passage point (egress).
 - (m)** Debrief time and location.
 - (5)** Contingencies.
 - (a)** Abort criteria.
 - (b)** Hasty decontamination site.
 - (c)** Downed aviator pickup procedures and points.
- 4. SERVICE AND SUPPORT**
- a.** Supply.
 - (1)** Class I.
 - (2)** Class II/IV.

Figure E-1. Sample format for a TAC SOP (continued)

- b.** Signal.
 - (1) SOI edition.
 - (2) Frequencies.
 - (3) Operational nets, net diagrams.
 - (4) ECCM.
 - (5) Antijamming procedures.
 - (6) Secure fills. Procedures and fill in use.
 - (7) Fixed call-signs.
 - (8) CVMS for division.
 - (9) Brevity codes.
 - (10) Have Quick and Have Quick II procedures.
 - (11) SINCGARS procedures.

6. SAFETY

- a.** Preaccident Plan.
- b.** Risk Management Procedures.

Time hack. Is it GPS? Some other time standard?

ANNEXES

- A.** Acronyms.
- B.** Reports. Ensure standardization with higher.
- C.** Alert Time Table.
- D.** Uniform and Packing List.
- E.** Precombat Inspections.
- F.** ASE. Operation and Use.
- G.** Liaison Officer Checklist.

Figure E-1. Sample format for a TAC SOP (concluded)

APPENDIX F

AIR COMBAT

F-1. GENERAL

An increasing number of countries have recognized the helicopter's effectiveness as a primary tool in destroying armor elements, providing ground maneuver commanders with a CS capability, and gathering intelligence information. A requirement to destroy helicopter forces performing these functions will exist from the viewpoint of all opposing forces, raising the probability of helicopter air combat in future conflicts.

a. Explanation of Terms. As used in this document, the term "air combat" describes those actions taken by Army helicopters against airborne threat fixed- and rotary-wing aircraft. These actions are defined by the key terms, "avoid," "evade," "threaten," and "engage," which represent the general philosophy of Army aviation toward the air threat.

b. Scope. Deliberate and chance encounters with enemy aircraft will occur throughout the battlefield and must be anticipated to protect the force. The scope of air combat operations will range from defensive actions that are required to protect an air assault force to limited offensive actions when aviation forces ambush an inbound enemy air threat. Commanders at all levels must acknowledge and plan for the possibility of air combat operations during all types of missions.

c. Battle Drills.

(1) The air combat battle drills presented in this appendix represent an evolution of TTP developed from the experiences of field aviation units and the results of Air-to-Air Combat Test Phase I and II, conducted at Fort Rucker, Alabama in 1993.

(2) The focus of the battle drills is on attack units, although they could apply to any unit. The drills are designed to provide a platoon of armed helicopters with immediate action steps to deal effectively with an air threat. Air combat drills are reactive in nature. Their primary purpose is to preserve the force so that it can accomplish the primary mission and return to fight again.

(3) The drills are based on the fire and maneuver concept with emphasis on C². The primary objective of the drill is to alert the force so that an immediate response to the threat may be initiated. This objective includes moving the force from a position of disadvantage to a more advantageous position.

FM 1-112

(4) Each battle drill consists of deliberate and standard phraseology and maneuver. When the force completes these initial standardized steps, the drill is over and the commander must make a tactical decision regarding the follow-on actions of his force.

d. **TTP.** The follow-on actions, or TTP, will vary as the commander evaluates each individual situation. The factors of METT-T affect his decision to avoid, evade, threaten, or engage the threat.

F-2. THE THREAT

Army aviation will make a decisive contribution to Army operations. Consequently, friendly aviation forces are considered both crucial combined arms assets and lucrative targets for threat aviation forces. Enemy attempts to dominate the terrain flight environment will be a constant threat to the success of combined arms operations.

a. Threat Overview.

(1) The primary threat to Army aviation within the terrain flight environment is ground-based AD. The air threat posed by both rotary-wing and fixed-wing aircraft, however, is increasing.

(2) As third world countries continue to modernize forces, the air threat to friendly helicopters becomes more significant. Forces committed against the third world threat are likely to encounter a mix of systems, tactical organizations, and doctrines that have their origin in the industrial nations of the East and West. A potential air threat can, therefore, be expected to operate a variety of sophisticated fixed-wing attack/fighter aircraft and armed helicopters that are available from industrialized nations.

(a) **Threat armor forces.** Enemy AD weapons, ground forces, helicopters, and high-performance aircraft are a major threat to Army aviation. Former Warsaw Pact doctrine calls for priority destruction of our antiarmor capability. With the improving antitank capability of our forces, that doctrine is expected to remain unchanged. Therefore, the more damage Army aviation can inflict on the threat's armor forces, the more the threat will concentrate on destroying Army aviation's antiarmor capability.

(b) **Threat aviation combat capability.** The US Army has increased its aviation combat capability; however, former Warsaw Pact member nations have also increased their capability at higher rates. As our air-to-ground effectiveness has improved, so has the threat's anti-helicopter efforts. To destroy Army aviation forces, the threat will use every available asset, to include tactical fighter aircraft and armed helicopters.

(c) **Threat awareness.** To defeat the threat, aircrews must understand the threat and its employment of air and ground assets. They must also understand the doctrine, tactics, and techniques of any potential enemy and its employment of

weapon systems. To be successful in air combat operations, commanders, tactical planners, and aircrews must know the capabilities and limitations of threat aircraft, air-to-air tactics, and air-to-ground tactics.

b. Helicopter Threat.

(1) The increasing numbers of attack helicopters available to potential hostile forces virtually assures the likelihood of meeting engagements. While the former Soviet threat has diminished significantly over the past several years, the fact remains that Russia's military approach to warfare will influence a number of third world countries, many of which are openly hostile to the United States.

(2) Western tactics have also had their influence on questionably aligned third world countries. Therefore, the tactics used by a helicopter air threat will vary from the high-speed slashing attacks typical of Soviet-developed tactics to the masked hovering engagements typical of western tactics. These engagements are likely to be brief, violent encounters; the win will go to the side that sees first, engages decisively, and successfully maneuvers its forces to cover and kill from the terrain flight environment. Our potential adversaries are offensively oriented forces. At the tactical level, they stress maintaining the momentum and exploiting penetrations with armor-heavy combat units. Their primary task at the FLOT is to suppress enemy antitank systems, which points out the value that the threat places on its armor forces.

(3) A growing concern that most armies have wrestled with for some time is the increasing threat that attack helicopters represent to armor forces. The technological advances in lethality, accuracy, and speed of the ATGMs carried by attack helicopters will amplify the role that attack helicopters play. The use of attack helicopters in the lower spectrum of conflict is also on the rise with the increasing military growth of third world countries. Armed helicopters are playing an increasing role in armed reconnaissance, security operations, and raids. As its tactics and uses are developed, the helicopter will be employed throughout the entire continuum of operations.

c. Fixed-Wing Threat.

(1) The high performance fixed-wing threat against helicopters cannot be dismissed. However, the likelihood of the fixed-wing threat targeting friendly helicopters as anything other than targets of opportunity is remote. The range of operations, speed, and operating environment of the helicopter makes it a relatively low priority target for fixed-wing aircraft. In terms of cost effectiveness, the helicopter is a more suitable target for ground-based weapon systems or for other helicopters.

(2) Fixed-wing aircraft operate at a significant tactical disadvantage when attacking helicopters that are operating in the terrain flight environment. These aircraft are not adequately equipped for specific search-and-destroy helicopter missions. In addition, they become lucrative targets for increasingly sophisticated helicopter air-to-air

FM 1-112

weapon systems. For this reason, the battle drills in this appendix are designed primarily for reaction to other helicopters. The high rates of closure of the high performance fixed-wing threat aircraft and the lack of suitable early warning devices in the cockpits of friendly helicopters may not allow the pilots time to react.

(3) If terrain permits and the threat has not detected the formation, the best COA is for the friendly aircraft to disperse and mask. Movement alerts overflying aircraft to the presence of potential targets. Therefore, any movement over the ground should be minimized, if not completely eliminated.

(4) If a fixed-wing threat detects a formation of rotary-wing aircraft, the targeted aircrew should fly toward the attacking aircraft as they perform a series of jinking maneuvers. Once the threat has overflown the targeted aircraft, the aircrew should mask. Other aircraft should disperse, mask, and prepare to engage the threat.

(5) Friendly helicopters should avoid prominent features that can be readily identified from altitude. For example, a sharp bend in a river gives the pilot of the threat aircraft a RP for additional passes. Downed aircraft are also conspicuous references, and crews of friendly aircraft trying to assist risk the same fate.

F-3. FUNDAMENTALS

Helicopter air combat doctrine has been developed in the absence of actual combat experience. The generation of air combat TTP is, therefore, evolutionary. Extensive testing and training have shown that adherence to various employment considerations, such as the tenets of Army Operations, the principles of war, and the factors of METT-T, result in effective air combat tactics. To plan and conduct successful air combat operations as part of the primary mission, commanders and aircrews must understand and use these employment considerations.

a. **Purpose.** Battle drills and TTP provide Army aviation with the tools needed to perform its primary mission in an air threat environment.

b. **Analysis of the Mission.** An analysis of air combat missions (mission debriefs) further refines tactics and makes them successful techniques and procedures upon which unit SOPs and battle drills can be based. While keeping their focus on the objective (commander's intent), leaders at all levels also must ensure that their tactical decisions enable them to win the small air combat engagements.

(1) **Air combat engagements.** Air combat operations must be responsive and effective. The AD early warning net, cues from ground forces, and other combined arms fires enhance the aviation unit's ability to maneuver to positions of advantage against threat helicopter forces. Effective massing of fires provides immediate suppression that enables the aviation unit to disengage from or destroy the air threat by fire and maneuver and continue the mission.

(2) **Unity of Command.** Unity of command is critical because of the flexible, dynamic, and fast-paced tempo of air combat operations. In seconds, actions taken or not taken could determine the outcome of air combat engagements. Aggressive air combat operations allow the commander to gain the initiative, impose his will on the enemy, set the terms for battle, and exploit windows of opportunity.

c. **Keys to Success.**

(1) **Planning, surveillance, and battle drills.** Continuous planning, constant surveillance, and well-rehearsed battle drills are keys to success in an air combat environment. To succeed in air combat, aviation commanders must--

- Plan for air combat regardless of the assigned mission.
- Always provide security for unarmed aircraft conducting deep operations.
- Attack aggressively at maximum standoff ranges and minimize decisive engagements, if possible.
- Use fire and maneuver tactics when engaging or delaying against an enemy aviation force.
- Use terrain and weather effectively.

(2) **Maneuverability.** Aviation forces should never lose the ability to maneuver and, normally, they should avoid becoming decisively engaged. Decisive engagement may be followed by systematic attrition. When this occurs against a numerically superior aviation force, the element involved must seek to break contact. Units should use coordinated fire and maneuver with available combined arms team fires to regain the freedom to maneuver.

F-4. EMPLOYMENT

Army aviation doctrine reflected in air combat operations contributes to the principles of war. As discussed in this section, the application of the battle drills and TTP support these principles.

a. **Principles of War.**

(1) **Objective.** The aim of every military operation must be directed toward a clearly defined, decisive, and attainable objective. The battle drills provide the tools that permit an organization to react decisively to an air threat. They allow the commander to either avoid or decisively engage the threat to discourage or destroy it so that the original mission may be accomplished.

(2) **Offensive action.** Offensive action is the most effective and decisive way to attain a clearly defined common objective. The battle drills give the commander the flexibility to seize, retain, and exploit the initiative by avoiding, evading, threatening, or engaging the threat. Although primarily defensive in nature, the focus of the battle drills is offensive--fire and maneuver to gain the advantage over the threat. The drill is executed to deter or destroy the threat before it can affect the mission objective.

(3) **Mass.** The principle of mass dictates that combat power be concentrated at the decisive place and time to ensure success. The battle drills facilitate both mutual support and the massing of fires by using the agility and speed of helicopters to concentrate forces at the decisive place and time.

(4) **Maneuver.** Army aviation's inherent agility and speed allow commanders to maneuver their elements to place the enemy in a position of disadvantage. The battle drills capitalize on these characteristics to maneuver aviation forces from a position of disadvantage to a position of advantage after the threat is first observed.

(5) **Economy of force.** Economy of force allocates minimum essential combat power to secondary efforts. To defend the force, the battle drills are executed to commit quickly the most efficient maneuvering element (platoon or team) when and where the threat is detected. At the commander's option, additional forces may be committed against the threat.

(6) **Unity of command.** This principle specifies that for every objective, unity of effort is combined under one responsible commander. The battle drills are initiated by the first aircrew to detect the threat. Although he relinquishes C² of his organization for this brief time, the commander automatically regains C² as he becomes aware of the tactical situation and maneuvers his unit to gain the advantage over the threat.

(7) **Security.** This principle requires that tactical security and protective measures be taken to prevent the enemy from acquiring an unexpected advantage. The fundamentals of air combat emphasize maintaining a high level of situational awareness to protect the force from threats that originate from the ground and in the air. Battle drills provide armed helicopters a way to protect the force in a multidimensional environment. Timely application of the battle drills keeps the threat from gaining an unexpected advantage over friendly forces.

(8) **Surprise.** Surprise can decisively shift the balance of combat power. By employing surprise, forces can achieve success out of proportion to the effort expended. The rapid reaction and aggressive execution of the battle drills and the follow-on TTPs give aviation forces the advantage of surprise. These actions confer initiative, threaten enemy morale, and reduce friendly casualties.

(9) **Simplicity.** Simplicity contributes to successful operations. Simple plans and clear, concise orders minimize misunderstanding and confusion. By definition,

a battle drill is a collective action that does not require application of a deliberate decision-making process. The battle drills are efficient and uncomplicated reactions to a threat. Practice ensures thorough understanding and instinctive execution.

b. Army Operations Doctrine. Army Operations doctrine describes our approach to generating and applying combat power at the operational and tactical levels. It is based on securing or retaining the initiative and then aggressively exercising that initiative to accomplish the mission. Success on the battlefield depends on the Army's ability to fight according to five basic tenets. These tenets are initiative, agility, depth, synchronization, and versatility.

(1) Initiative. Initiative is attained by setting or changing the terms of battle through aggressive action and, in part, through independent action. This action allows the force to capitalize on windows of opportunity and enemy vulnerabilities. The aircrew member that first observes the threat prompts the battle drill. The battle drills are aggressive responses that allow friendly forces to avoid, evade, threaten, or engage the threat. Whatever COA or combination of actions that are taken, the battle drills place friendly forces in a position to capitalize on enemy weaknesses.

(2) Agility. Agility is the ability of friendly forces to act faster than the enemy. It permits the rapid concentration of friendly strength against enemy vulnerabilities. The time between battle drill initiation and force maneuvering under TTP is minimal. To take advantage of threat vulnerabilities, the battle drill allows friendly forces to immediately respond to the threat with a coordinated effort.

(3) Depth. Depth is the extension of combat operations in space, time, and resources. Depth implies preparedness throughout the spectrum of operations. Successful air combat operations gain time to plan, arrange, and execute combined arms operations. The rapid, precise execution of the battle drills emphasizes depth in operations. They give the commander time to plan and the opportunity to execute follow-on TTPs.

(4) Synchronization. Synchronization is the process of arranging combat actions in time, space, and purpose to develop maximum combat power from available resources. The battle drills coordinate a precise set of actions to provide maximum combat power from a platoon of two to three armed aircraft.

(5) Versatility. Versatility is the ability to shift focus, tailor forces, and move from one mission to another rapidly and efficiently. The battle drills reflect versatility in their design and in what they accomplish. Avoiding, evading, threatening, or engaging enemy forces displays a staged approach based on the level of the threat. The drills increase the level and degree of involvement as required. This staged approach quickly commits forces to deal with the immediate threat then allows friendly forces to continue with the original mission.

c. **Air Combat Philosophy.** Army aviation's role in air combat is those defensive and limited offensive actions taken by Army helicopters against airborne rotary- and fixed-wing threat aircraft. Limited offensive actions are emphasized because of the potential for offensive actions to detract from the overall support of ground forces. Limited offensive actions are also emphasized because of the questionable success of extensive helicopter air combat operations in a terrain flight environment and the current limited capabilities of friendly attack aircraft in the air-to-air role.

d. **Air Combat Tenets.** Current US Army air combat philosophy is based on tenets that serve to alert the force of a potential or impending air encounter, maneuver the force into a position to provide mutual support, build situational awareness throughout the unit, and result in the commander's ability to exercise full C² over his force. On the other hand, current doctrine reflects a procedural approach of avoiding, evading, threatening, and engaging threat aircraft. Each of these options incorporates the tenets that ensure the effective initiation of the battle drill and the smooth transition to the follow-on TTPs.

(1) **Alert.** The alert call is critical to the survival of the force. The alert is transmitted by the aircrew that first observes the threat. The crew who, at the moment the threat is observed, has the highest level of situational awareness. The alert is a brief message that instantly raises the situational awareness of the force to the presence of a threat, to the direction of the threat, and of the response to be taken to avoid, evade, threaten, or engage the threat. The alert is a command to act.

(2) **Maneuver.** The battle drill is an instinctive response to the alert call. It is a preplanned maneuver that coordinates the movements of the friendly elements from a position of disadvantage to a position of advantage against the threat.

(3) **Mutual support.** The execution of the battle drill places friendly aircraft in position to mutually support the movements of each other. If necessary, friendly forces can fire to support maneuver requirements.

(4) **Situational awareness.** Operation in the tactical environment requires that each member of the force maintain a high level of situational awareness. This is obtained through a continual education on threat tactics and weapon system capabilities. It is also obtained through the mission briefing, which is enhanced or updated continuously during the mission through observation and communication with other members of the force. Most important, situational awareness is provided to other members of the element through radio calls and updates as changes occur.

(a) Situational awareness obtained through observation must include all dimensions of the battlefield, both ground and air. Situational awareness obtained through communication should be as required to relay EEI to the force.

(b) During air combat operations, the aircrew that first observes the threat calls the battle drill. The drill alerts the remainder of the force and instantly

increases its situational awareness of the developing situation. The drill orients the force so it can avoid, evade, threaten, or engage the threat.

(5) **C²**. The outcome of an air combat engagement depends on the successful execution of the correct battle drill and the follow-on TTP. The commander must be able to make an immediate and accurate assessment of the situation as it unfolds and maneuver his forces to avoid, evade, threaten, or engage the threat. Activation of the battle drill by any friendly crew gives the commander the critical seconds he needs to retain or regain C² to formulate proper follow-on actions.

e. **Air Combat Doctrine**. The Army's defensive air combat doctrine is to avoid, evade, threaten, and/or engage the threat. The order in which this doctrine is presented shows an increasing level of involvement with a persistent threat--a best-case to worst-case scenario. It is the desired, not the mandatory, approach to the threat. Avoidance may not be an option. For instance, circumstances may require that a threat be engaged immediately or that a combination of evading and threatening be applied simultaneously.

(1) **Avoid**. Unless directed by mission orders, friendly aviation forces should maneuver to avoid being observed by threat aircraft. Avoidance ensures that friendly forces can continue to accomplish the mission without interruption. Avoidance may be accomplished either passively or actively. While passive avoidance stresses effective use of terrain and ASE, active avoidance emphasizes physically avoiding an observed air threat; for example, changing the route of flight.

(2) **Evade**. If time and maneuver space permit, friendly forces should use the terrain flight environment to evade the threat if they are observed. This action should be used to the advantage of the friendly force to avoid an engagement. Friendly forces should not attempt to evade if maneuver space is inadequate or if evading the threat will result in a tail chase.

(3) **Threaten**. If the threat has initiated aggressive action and avoidance or evasion is not an option, the friendly forces should execute the appropriate battle drill to orient their weapons on the threat. The threat may break off and avoid an engagement at the appearance of a well-coordinated, formidable defense.

(4) **Engage**. If the threat was avoided, evaded, or threatened and the action was found to be inappropriate or unsuccessful, the friendly forces must act immediately and aggressively to engage and destroy the threat.

f. **Air Combat Imperatives**. Several air combat maneuvering concepts have proven to be successful in the air combat environment. Although these principles originated from fixed-wing experiences, they have specific application to helicopter air combat operations. A successful engagement depends on effective lookout procedures. The timely receipt of an attack warning and prompt, accurate communication of the attack to other aircrew members is critical. Friendly forces must be able to recognize the threat based on more than the physical characteristics of their aircraft. They must be

FM 1-112

familiar with threat tactics and be able to recognize the threat's intent quickly. The mission briefing should address the required actions if friendly aircraft see the threat first. The mission may require friendly forces to bypass the threat or engage it immediately. If the threat is bypassed, friendly forces should forward EEI to the next higher headquarters.

g. Observation Sectors.

(1) Individual aircrew members should maintain specific lookout sectors from the cockpits of their aircraft. The unit SOP should address and standardize these sectors by the type of aircraft and formations. Each aircraft in the formation should also maintain lookout sectors that the commander assigns. As much as aircraft cockpit design will permit, the sectors of observation should equal 360 degrees around the aircraft and formation.

(2) Commanders should analyze the factors of METT-T to determine if other methods of observation should be employed. For example, if an attack from the rear sector is possible, friendly forces may find it necessary to perform "S" turns or conduct frequent check turns to maintain observation in that sector. Utility and cargo aircrew members/door gunners can also help maintain observation to the rear and flanks of their aircraft and the formation.

(3) Sectors of observation also must include vertical airspace. Crews should scan areas out to the maximum effective ranges of the expected threat weapon systems. (Visual search techniques are discussed in TC 1-201.)

(4) There is no safety in numbers. Aircrew members must not become complacent and assume that other crew members will detect the threat first. They must maintain a constant visual watch. Multiple sets of eyes scanning the same sectors reduces the chances of threat aircraft approaching a formation undetected.

h. Lookout Techniques. A large number of air-to-air kills in World War I, World War II, Korea, and Vietnam were achieved through complete surprise. Seeing the enemy first is the key to survival in an air combat environment. In addition to visual observation, any tool available should be used to "see" the threat. Some of these tools might include the AWACS, FAAD system, or AH-64D Longbow radar. Lookout techniques are discussed in the paragraphs that follow.

(1) **Avoid detection.** If the threat detects friendly aircraft, the friendly aircraft become targets. Friendly forces must, therefore, employ proper terrain flight techniques and ECCM to avoid visual and electronic detection.

(2) **Recognize the threat.** All aircraft should be considered hostile until they are positively identified. The eastern and western industrialized nations have had a significant influence on third world military aircraft inventories. Identifying an aircraft as friend or foe has become increasingly difficult. Aircraft identification based entirely on

its physical characteristics is dangerous. Aircrew members must be familiar with the capabilities, weapons, and tactics of all potential threat aircraft.

(3) Evaluate the threat. Aircrew members must assess the difference between nonaggressive maneuvering and maneuvering in preparation for attack. The results of this assessment may be the first indication of whether the threat is searching or passing through and if it has detected friendly aircraft. If detected, friendly aircraft must execute the appropriate battle drill and avoid, evade, threaten, or engage the threat as the situation dictates. A drill may not be necessary to call if detection of the threat is made with sufficient time to make a tactical decision.

(4) Decide to engage. Once friendly aircraft have been detected or engaged by the threat, they must act immediately. They must execute the correct battle drill, become the aggressors, and set the tempo of the engagement. Friendly forces must fire first to kill or discourage further aggressive actions as they maneuver to deny weapons employment by the threat. The commander's decision to commit follow-on forces depends on the factors of METT-T.

(5) Be unpredictable. Repetitive patterns of response by friendly forces increase the potential for the threat to gain and maintain an advantage. Aircrew members must maintain situational awareness at all times, especially during an engagement. Timely communication between aircrew members enhances coordination and situational awareness and allows for distinct, unpredictable maneuvering.

i. Situational Awareness. A successful air combat engagement is a function of the preparation and responsiveness of each member of the platoon. The immediacy of action at the time friendly forces execute the battle drill requires a high degree of situational awareness. All aircrew members must know the threat, mission profile, routes, and actions on contact (battle drills). They also must know the ROE, mission abort criteria, and other elements discussed in the air combat maneuvering concepts. Each aircrew member must know the position or relative position of the other aircraft in the platoon or company.

j. Execution.

(1) The battle drills in paragraph F-7 are to be executed at platoon level and below. In the drills, the assumption is made that a two-aircraft element is the basic and most efficient maneuvering element. When a third aircraft is part of the formation, it maintains a fixed position off an assigned lead. Movements of larger organizations should be built on this base element. As an example, the commander should organize his company for movement in two platoons.

(2) Attempting to execute a battle drill with more than one platoon significantly increases the complexity of the maneuver. It increases both the size of the target presented to the threat and the chance of fratricide, as it decreases the likelihood of

FM 1-112

a successful outcome. A larger maneuver element also reduces the commander's ability to maintain effective C².

k. Drill Initiation.

(1) The need for immediate response requires that the aircrew who first detects the threat initiate the battle drill. That aircrew must announce the battle drill with authority, and the remainder of the friendly elements must decisively execute the drill.

(2) The battle drill must be a simultaneous movement by multiple aircraft, and the threat must be destroyed or deterred. To do this, each crew in the platoon must understand the advantage each drill offers over the other.

(3) Execution of the battle drill meets the immediate requirement to alert and maneuver the force in response to a threat. The drill itself is complete within the first few seconds of the meeting engagement. Following the drill, the commander maneuvers his force to break contact (avoid or evade) or develop the situation (threaten or engage) as required.

F-5. HELICOPTER AIR COMBAT

While Army aviation units will conduct air combat operations as a unit, the engagement could scale down to individual helicopter-versus-helicopter engagements. Helicopter air combat engagements take place in four stages--target acquisition, closure and movement, weapons employment, and disengagement.

a. Target Acquisition.

(1) **Acquisition of enemy aircraft.** Air combat engagements, like other forms of combat, start with the acquisition of an enemy aircraft. The initial acquisition range varies with the terrain, altitude, flight profile, and weather. The normal acquisition range for NOE flight can be from less than 1 kilometer to more than 6 kilometers. Seeing the enemy first allows time to make decisions and react. Air combat drills also reduce the time required to act. Once seen, the enemy must be kept in sight; otherwise, any advantage gained is lost.

(2) **Means of acquisition.** Enemy aircraft can be acquired visually with the naked eye, binoculars, night vision devices, TSUs, or other optical systems. Also, cueing may be provided to aviation units from various battlefield sensors, thus enabling acquisition at extended ranges.

b. Closure and Movement. Once the enemy aircraft is sighted, the second phase of air combat begins. During this phase, the commander decides whether to attack and how to attack. While the basic tactics used will be fire and maneuver, the techniques will differ for armed and unarmed aircraft.

(1) Armed aircraft. Armed helicopters must remain undetected while their aircrews maneuver to a position where they can effectively engage the enemy aircraft. During this maneuver, they must be able to observe and place effective direct or indirect suppressive fires on the enemy aircraft. If armed aircrews cannot rapidly deploy to a hasty BP, they may have to conduct evasive maneuvers. In any case, maneuvering must either enhance concealment or gain a tactical advantage. A tactical advantage can be a superior firing position (ideally a flanking or a 6 o'clock position) relative to the enemy aircraft. It can also be a BP that uses dominant and protective terrain or the massing of aircraft fires for a short time on a smaller enemy force.

(a) Ideally, the closure and maneuver stage should end with the undetected armed helicopter in a concealed BP. It could also end with the armed helicopter possessing a superior firing position as a result of skillful maneuvering. Aircrews must be aware that in close and deep operations higher altitudes may subject them to enemy AD and combined arms engagements.

(b) Armed aircrews should fly and fight from the NOE environment. Masking terrain provides the best cover and concealment against ground and air threats. The NOE environment is also the best position from which aircrews can engage enemy helicopters. However, aircrews may have to gain an advantage by executing various flight maneuvers when available NOE firing positions are inadequate. Evasive maneuvers may be the only means of breaking contact when no advantage can be achieved. After breaking contact, aircrews should again deploy to NOE. When in the NOE environment, they can engage enemy aircraft from concealed BPs.

(2) Unarmed aircraft.

(a) If undetected and inadequately concealed, aircrews of unarmed helicopters should remain in the NOE environment and rapidly move to a position that provides better concealment. From the concealed position, aircrews should observe, report, and engage enemy aircraft with all available suppressive fires. Unarmed aircrews should also consider landing their aircraft to avoid detection. However, this sacrifices maneuverability and significantly increases vulnerability. When enemy aircraft no longer pose a threat, unarmed aircrews should report and continue with the mission.

(b) If detected, unarmed aircrews must attempt to remain in the NOE environment and regain cover or concealment. Placing masking terrain between the enemy aircraft and their aircraft enables them to break contact. Aircrews should also be prepared to execute evasive maneuvers to break contact, regain concealment, and continue with the mission. If they are unable to break contact, aircrews must request supporting fires from other members of the combined arms team to suppress or destroy enemy aircraft.

c. Weapons Employment. The third phase of helicopter air combat is the most decisive. Attack consists of direct and indirect fires on the enemy and logically follows maneuver. The goal of the attack phase is to fire first and destroy the opposing

FM 1-112

helicopter using all shock and firepower available. The quicker the enemy is destroyed, the better. The longer the engagement lasts, the greater the chance of defeat. The ATAS requires an arming and flight stabilization period that may affect lethality when used under 1,000 meters. Cannon and machine gun fire may be effective out to 1,700 meters and 1,100 meters, respectively. The long flight time and limited lateral and vertical tracking capability of ATGMs limit their use in ATA engagements. However, they can be employed out to their maximum effective range against helicopters that are not maneuvering excessively. Aerial rockets also have limited use in most ATA combat situations. However, they can be used during the maneuver phase to enhance target acquisition and to slow an attacker. In all cases, weapons must be selected quickly. For details on helicopter gunnery, see FM 1-140.

(1) **Recommended weapons use.**

(a) **ATAS.** The ATAS should be used at or near maximum range before the enemy can detect the US aircraft. In extended range firing, where the US aircraft has not been detected, the aircrew should be aware that the ATAS has a detectable smoke signature under certain atmospheric conditions. Although the ATAS may be used in short-range firings (under 1,000 meters), the minimum arming range may affect its lethality.

(b) **Cannon, 30-millimeter.** The maximum effective range of the 30-millimeter cannon is 1,500 - 1,700 meters. The projectile's excellent penetration, range, accuracy, and explosive properties make it effective for ATA combat against close-range and stationary targets. However, its slow rate of fire makes aerial target engagement difficult.

(c) **Cannon, 20-millimeter.** The maximum effective range of the 20-millimeter cannon is 1,500 meters. Although it can be used to engage enemy helicopters at close range, its slow rate of fire makes aerial target engagement difficult.

(d) **Machine gun, 7.62-millimeter.** The maximum effective range of the 7.62-millimeter machine gun is 1,100 meters. Tracer burnout is 900 meters, and maximum range is 2,500 meters. This weapon may not be effective against certain armor-protected areas on the Hind; however, it can cause significant damage to unprotected areas. This weapon can also be used effectively to break contact with enemy helicopters at close ranges.

(e) **Hydra 70 rocket system, 2.75-inch.** The maximum effective range for direct fire of the 2.75-inch Hydra 70 rocket system is 5,500 meters. The Hydra 70 is a good weapon for placing effective fires on enemy helicopter formations, for breaking contact, or for firing on helicopters in LZs. This MPSM rocket is also effective against enemy helicopters entering or departing LZs. Flechette rounds may be the optimum rocket munition for air combat. When employing this munition, aircrews should know the location of friendly ground elements to avoid fratricide.

(f) **TOW missile.** The effective range for ATA engagement of the TOW missile is between 500 and 3,750 meters. The time of flight for maximum range is 22 seconds. Since aircrews must allow 5 to 8 seconds for target acquisition and engagement, total exposure time will be from 27 to 30 seconds. Aircrews can use the TOW missile against head-on, tail-on, or slow-flying enemy helicopters. It is also effective against helicopters at a hover. However, the TOW missile may not be effective against fast-flying targets that are moving laterally or vertically.

(g) **Hellfire.** The maximum effective range of the Hellfire missile is over 8,000 meters. With an onboard laser designator, aircrews can engage targets out to maximum effective range. Ideally, aircrews should engage enemy helicopters indirectly with the Hellfire. The target can be designated by scout or ground lasers. This enables aircrews to fire the missiles from concealed positions behind masking terrain. The same considerations for engaging enemy aircraft with the TOW missile apply when engaging with the Hellfire. However, this missile is not as constrained by velocity as is the TOW missile.

(2) **Suppressive fires.** Helicopter crews should use all available suppressive fires to destroy enemy aircraft. These include AD, mortars, armor, FA, and small arms fire from ground units. Using other combined arms weapon systems conserves helicopter ATA weapons. It also provides unarmed aircrews with an effective means of destroying enemy helicopters.

(3) **Helicopter engagements.** Engaging other helicopters, particularly armed helicopters, is more complicated than dealing with ground targets. Because speed and maneuverability differ, fighter aerial combat maneuvers have only limited application to helicopter engagements. For this reason, it is important to achieve surprise and to fire first. But aircrews should not fire at an enemy helicopter that has not detected them unless there is a good P_k . If they fire and miss, they will only alert the enemy to their position. Proper evaluation of the enemy helicopter is critical for proper weapon selection.

d. **Disengagement.** Disengagement is the final stage of air combat. It essentially consists of a rapid, concealed exit. Aviation units can disengage effectively from enemy helicopters by executing fire and movement tactics. Throughout the history of fixed-wing ATA combat, more aircraft have been destroyed while disengaging than in any other phase of air combat. This can be attributed to many factors, but the greatest danger is when aircrews become relaxed and careless. Disengagements are normally either free or forced. They may also occur during a surprise attack or chance encounter.

(1) **Free disengagement.** Free disengagement occurs when the opposing aircraft has been destroyed or has withdrawn and pursuit is not required. The free disengagement is at the discretion of the aviation commander.

(2) **Forced disengagement.** Forced disengagement is dictated by circumstances such as low fuel, malfunctioning weapons, depleted ammunition, wounded crew members, or aircraft damage. The primary way to conduct forced disengagement as a

FM 1-112

unit is to use fire and maneuver tactics. For example, one element provides a base of fire while the other element disengages from the enemy. The pilot must use stealth, speed, and maneuverability to evade the enemy. To help ensure successful disengagement, he should fly at low altitude, use covered, concealed routes, and exit at high speed.

(3) **Surprise attack or chance encounter disengagement.** A third form of disengagement may occur during a surprise attack or chance encounter when round impact or visual detection occurs at short range and there is no time to execute a battle drill. The aircrew under attack must immediately seize the initiative. To accomplish this, the aircrew changes altitude, makes an immediate turn into the enemy aircraft, and fires its available weapons. The close-range fire should distract the enemy and allow the aircrew to disengage or gain a superior firing position by maneuvering the aircraft.

F-6. ENGAGEMENTS WITH ENEMY FIGHTERS

Enemy fixed-wing fighters are not Army aviation's most probable air threat. However, they do possess a great air-to-air capability that aircrews must be aware of and prepared to counter. Encounters that Army aviation units will have with enemy fighters will be primarily defensive. As in all tactical employment, effective use of fire and maneuver, coupled with effective terrain flight techniques, is the key to successful engagements. The employment considerations discussed earlier apply to potential engagements with the entire spectrum of the air threat. For example, aviation units that have acquired a fixed-wing threat may or may not decide to engage after having considered the factors of METT-T, especially if the mission dictates otherwise.

a. The enemy fighter may decide not to engage the helicopter if it receives a higher priority mission. Therefore, the aircrew may never know that it was acquired by the enemy fighter. Also, the enemy fighter may consider an attack on the helicopter too risky because of the presence of friendly fighters or the threat posed by local AD weapons. As a rule, a fighter will execute some telltale maneuvers before it attacks. These maneuvers include circling, flying toward the helicopter, and suddenly climbing. The fighter's range and altitude will determine if it is in a position to attack. If it is not in a favorable position to attack, the fighter will have to turn, climb, or both. Since the turning radius of modern fighters is quite large, the pilot may lose sight of the helicopter during a turn. If so, he may have to orient the attack on the last location of the helicopter.

b. The fighter pilot will begin the firing pass and attempt to reacquire the helicopter. Normally, his reacquisition will occur about halfway down the attack run. If the helicopter has moved to another concealed location, even as short a distance as 100 meters, the fighter may not be able to engage on that pass.

c. If the enemy fighter pilot executes a dive, the helicopter may have been acquired. A fighter pilot prefers to attack from altitude to give himself time to line up the target in his sights. The steeper his dive angle, the greater the accuracy of his fixed, forward-firing weapons. He can experience difficulty in a steep, high-speed dive close to

the ground. If he is unable to pull out soon enough, his downward momentum could force him into the ground.

d. Receiving fire is another indication that the helicopter is under attack. Fighters are almost invariably armed with fixed, forward-firing weapons that require the pilots to line them up on targets. For a well-aimed shot, the pilot must track steadily. Even though the helicopter is concealed, it can still be hit if the fighter pilot fires in its general location. Tree bursts and ricochets from exploding projectiles can be as fatal as direct hits.

F-7. PLANNING CONSIDERATIONS

Commanders must anticipate the employment of Army aviation in air combat operations. They must consider many factors that may affect the unit's response to an air threat. Air combat planning fundamentals should include, but not be limited to, analysis of the factors of METT-T; the ROE; and the most effective formation and maneuvers that position the force against an anticipated threat. Air combat planning should also include determining what systems may be available to provide early warning and how the elements of C³ can be honed to reduce response time.

a. METT-T. The employment of any force requires an analysis of the factors of METT-T. The commander must expect deliberate and chance encounters with enemy aircraft to occur on the battlefield and tailor his forces accordingly. Specific employment techniques may differ depending on where operations will occur on the battlefield--close, deep, or rear.

(1) Mission.

(a) The aviation commander must understand his organization's mission and his commander's intent. Air combat operations may be a specific mission. The air combat mission may be to protect the overall effectiveness of the combined arms team or to protect the aviation unit and preserve its effectiveness. Finally, friendly forces may exercise the battle drills in self-defense. For example, an ATKHC may be assigned air combat as a specified mission to support an air assault force, while air combat may be the implied mission of an air cavalry troop conducting a screen operation.

(b) Mission planners should consider all options when the possibility of encountering an air threat exists. These considerations might include avoiding enemy aviation forces or employing other combined arms to destroy the threat. They also might include delaying or destroying the enemy to provide reaction time and maneuver space.

(2) Enemy. The increasing numbers and sophistication of potential threat aircraft greatly increase the likelihood of planned or accidental meeting engagements between helicopters. All aircrew members must know the threat's capabilities. Aviation units should disseminate information on threat aircraft, weapons, and tactics using

FM 1-112

classified and unclassified sources and mission debriefings. Knowing the threat capabilities enhances the probability of success.

(3) **Terrain.**

(a) Terrain affects air combat planning and operations. The use of valleys, draws, or marginal weather to mask the movement of helicopters is not a skill or capability unique to friendly forces.

(b) The threat helicopter's performance and its ability to conduct terrain flight operations are improving. The ability of threat aircraft to operate in marginal weather and at night assures that these are no longer exclusive capabilities of friendly forces. Realizing this, planners must use some degree of unpredictability to offset the mutual advantages of terrain and weather.

(4) **Troops.**

(a) The availability of troops impacts on mission planning and organization for combat. The types of forces available, such as AD, CAS, Army aviation, and artillery also will influence mission planning.

(b) Army aviation units may perform specific offensive air combat to augment the AD mission. These missions, however, will restrict the potential of attack and reconnaissance units as a maneuver force that is fully integrated into the ground tactical plan.

(5) **Time available.** Time may not be available to adequately plan a mission. To defeat the threat, quick reaction missions require innovation and flexibility. Preparation for either a planned or an unplanned air combat engagement, however, must occur well before the mission. All aircrew members must understand threat capabilities and be able to perform the battle drills in paragraph F-9.

b. Tactical Employment Considerations. Several factors should be considered when aviation units are employed in air combat operations. These factors include flight altitudes, the selection of routes and BPs, chance encounters and meeting engagements, and reactions to ambushes. Other factors include security for unarmed aircraft and the execution of air ambushes or interception of enemy helicopters.

(1) Combat aviation units must fly at terrain flight altitudes. Terrain flight masks the aircraft from visual and radar systems, hinders IR systems engagement, and provides some cover from weapons effects.

(2) Selected routes and BPs should allow units to see the enemy first. Ideally, routes in and out of BPs should provide concealment during ingress and egress.

(3) When chance encounters or meeting engagements occur, units must use fire and maneuver to destroy enemy aircraft or to break contact. At short range, aircrews may have to use air combat maneuvers to break contact or gain superior firing positions. Even at close range, aircrews must attempt to use mutually supporting fires and avoid decisive engagements that result in mutual attrition.

c. **ROE.** Depending on the mission, the ROE may change. Every mission briefing should address the ROE.

(1) The terrain flight environment may provide fleeting glimpses of maneuvering aircraft sharing the same airspace. All aircrew members should be constantly vigilant and search for other aircraft sharing the same airspace.

(2) Friendly forces should not engage unidentified aircraft unless they exhibit aggressive behavior. Self-preservation and the protection of the force requires that all unidentified aircraft be considered a threat until they are positively identified.

(3) To avoid fratricide, mission briefing considerations for ROE should include precautionary measures while battle drills or the follow-on TTPs are being performed.

d. **Tactical Movement, Formations, and Maneuvers.** Air combat does not require special techniques of movement or special formations. To maneuver on the battlefield, friendly forces will use traveling, traveling overwatch, and bounding overwatch flown in free cruise, combat cruise, and combat spread. As shown in Chapter 3, spacing guidelines established for combat cruise and spread formations enhance reaction to the threat and increase survivability.

(1) The assumption is made in the battle drills that a two- to three-aircraft element is the basic maneuvering element. Movement of greater numbers of aircraft should build on this base element. Executing a battle drill with more than a platoon (more than three aircraft) significantly increases the complexity of the maneuver. It increases both the size of the target presented to the threat and the chances of fratricide as it decreases the chances of success.

(2) The commander determines the separation between his elements. The spacing he establishes for the follow-on platoon gives him time to analyze the tactical situation. It also gives the commander time to decide whether to support or bypass the engagement that the other platoon initiates.

(3) If the commander must maneuver with three aircraft, the third aircraft will maintain a position off one of the other aircraft. The crew of the third aircraft maneuvers with his assigned lead, mimicking the lead's movements. This allows the platoon to be controlled as if it consisted of only two aircraft.

(4) In addition to simplifying the execution of the battle drill, placing the third aircraft in a fixed position offers other advantages. It allows the commander to place his least experienced crew with the most experienced crew. It also gives him the flexibility to place the strong side of the formation toward the threat.

e. **Early Warning.** Aircrews of Army helicopters have a limited visual detection capability from the cockpit. Weather, obscurants, and other factors further affect this capability. The limited fields of view of the avionics on the AH-64, OH-58D, and AH-1 helicopters do not provide a suitable self-contained, search and warning capability.

(1) Actions in the cockpit can distract an aircrew member from his observation sector. During these brief periods, threat aircraft can move into position to take advantage of friendly vulnerabilities. This may be more significant when the threat approaches from the rear.

(2) Commanders should determine the availability of advanced warning from the FAAD system radar or the AWACS. When the Longbow Apache and Comanche are available, they will provide an onboard capability to search beyond visual range in all sectors. The advanced warning provided by these systems increases both survivability and the commander's options. These systems will give him additional planning and reaction time so he can avoid, ambush, or take other action he deems appropriate.

f. **C³.**

(1) **Terminology.** A battle drill is an automatic response to a stimulus. It is intended to reduce confusion and enhance C³. Paragraph F-8 contains specific terms critical to activating a drill. These terms direct specific action with clear, distinct terminology.

(2) **Use of a common RF.** To perform battle drills and execute coordinated TTPs, all members of the unit, whatever the size, must respond simultaneously. Therefore, all elements need to monitor a common RF.

(3) **Activation of the battle drill.** Friendly forces must respond immediately to an air threat. This requires that the crew that first observes the threat initiate the battle drill. Until the commander gains situational awareness, he will respond to the command (the alert call) initiated by the crew that first observed the threat. Once the commander regains situational awareness, he maneuvers his force with the appropriate TTP to avoid, evade, threaten, or engage the threat.

(4) **Position of the commander.** The commander should position himself where he can maintain situational awareness. Based on the factors of METT-T, the commander should select a position that gives him time to evaluate the evolving tactical situation and direct the correct TTP. The commander should not be responsible for

primary navigation of the formation or have primary responsibility for rear area security. He should not assume any task that keeps him from overseeing and directing the mission.

NOTE: Because the factors of METT-T are far too numerous and varied, this appendix does not designate the commander's position in the formation. However, his position is important, and it must be given careful consideration.

F-8. TACTICAL OPERATIONS

This paragraph discusses the planning and execution of air combat operations throughout the spectrum of the battlefield. The tactical scenarios are representative situations. They provide leaders at all echelons with examples of how to fight air combat. Army aviation forces will be employed in the close, deep, and rear operational areas of the modern battlefield. Based on the assessed enemy tactics and the doctrine stated earlier, air-to-air combat between opposing aviation forces will occur in future conflicts. Therefore, aviation commanders must plan for air combat. Their aircrews must prepare, using all available assets, to defeat the enemy air threat. Failure to do so will degrade Army aviation's ability to accomplish its primary air-to-ground mission. Aviation units will conduct air combat as an extension of their traditional mission as a maneuver arm of the combined arms team. When analyzing the factors of METT-T, commanders must consider the air and ground threat to ensure that the basic principles of doctrine (the tenets of Army Operations and the principles of war) are best met by the TTP they choose.

a. Deep Operations/Air Assault Security. Air combat in deep operations will result primarily from the need to secure air assault or deep attack forces. Air combat in deep operations may be unavoidable because of meeting engagements or enemy air-to-air intercepts. However, it should be averted, if possible, because of enemy AD and its combined arms capabilities. When air combat in deep operations is unavoidable, engagements should be kept short. The objective should be quick destruction of the air threat or its rapid disengagement.

(1) Air combat should be planned to secure attack forces in the deep battle area. This planning requires detailed, real-time intelligence and requests for and use of joint acquisition systems. Planners must also integrate all available close air, indirect fire, and EW support. Planning and coordination for J-SEAD operations will be critical in deep operations.

(2) Since there is a potential for air-to-air engagements during deep attacks, only the time needed to complete the mission should be spent in the deep battle area. If possible, deep attacks should be conducted at night. Darkness and reduced visibility will aid aviation commanders in protecting the force.

(3) Planning for combat operations, including deep attack air assault missions beyond the range of friendly AD coverage, must include the use of attack or air cavalry units to provide security from enemy air attacks. Attack aircraft must provide security for unarmed aircraft during deep operations. Also, air threat forces can be

FM 1-112

expected to hide in ambush positions and attack US deep attack forces from the flanks and rear. Security of the assault formation may be enhanced by an integrated lookout plan. Therefore, each aircraft within an assault formation must have assigned overlapping search sectors.

(4) The effects of speed versus stealth must be considered when deep operations are planned. Higher speed may result in higher altitudes, which result in easy detection and vulnerability to enemy ADA systems. Conversely, higher speeds decrease the time spent across the FLOT, which lessens the probability of interception if detected. Lower airspeeds and NOE altitudes decrease detection but increase the time deep attack forces are employed in enemy territory.

(5) During combat in deep operations, attack and scout aircraft plan for enemy air attacks. When used as security forces for an air assault or a ground maneuver force, they provide local air security, suppressive fires, and reconnaissance. Aviation forces use onboard ASE, CAS, long-range artillery, and terrain flight techniques to degrade enemy air attack effectiveness. The security force destroys, neutralizes, or delays enemy short-range air attacks. During air assaults, attack helicopter or air cavalry units use fire and maneuver tactics to engage and neutralize the enemy. Security forces provide screening and suppressive fires en route and during insertions or raids. When required, they can also provide preparatory fires into landing zones. Their most important task, however, is to prevent enemy aircraft or ground forces from jeopardizing the mission.

(6) The aviation force that provides security must be aggressive and sufficiently removed from the main body to provide reaction time and maneuver space. The scout elements of the security force should be employed to gain first sighting and report the threat so a timely decision can be made. Actions on contact must be briefed to the security element, directing them to destroy, delay, or avoid contact. The decision cycle is thus shortened should late acquisition of an air threat occur.

(a) If ordered to **destroy** the threat, the security element should engage with the ATAS at maximum effective range. It should also attempt to lure, deceive, or force the air threat into the attack helicopters' fire. During the engagement, attack aircraft maneuver into attack positions to counter the anticipated enemy movement. The attack element should be organized into fire and maneuver elements to provide close mutual support during the attack on the air threat. Fire and maneuver elements also provide flexibility for an adjustment to the enemy's unexpected actions.

(b) If ordered to **delay** the threat force so that the mission can be completed, the security force will attempt to prevent the threat force from closing with the main body of the assault force. Fighting from subsequent BPs, the fire and maneuver sections of the attack element trade space for time while avoiding decisive engagement.

(c) If ordered to **avoid** detection and engagement by the threat force, the security element will mask and continue to report to the assault force commander. The assault force will then have to maneuver to avoid detection by the threat force.

(7) The decision to engage the threat with insufficient forces or the failure to gain the first sighting may allow the threat forces to overrun the security forces and the antitank or assault forces they are securing. This will result in a decisive engagement in enemy territory and possible heavy attrition of aviation forces. In this situation, aviation forces must execute prebriefed actions on contact to disengage and reconstitute. Aviation forces must continue to fight as a unit and provide mutual support during the engagement.

(8) The security force operation that supports an air assault force will be planned and executed based upon the factors of METT-T. The security force should be formed as shown in Appendix C. The location of the subelements of the security force are positioned to enhance--

- Mutual support between aircraft against air and ground threats.
- Flexibility to maneuver to any area around the air assault or deep attack force.
- Element of surprise by using a small, tightly controlled force to penetrate enemy forces.
- Massing of timely, decisive combat systems.
- The 360-degree security by integrating all organic firepower into the fire distribution plan (cannons, rockets, and missiles).
- Simplicity.

(9) Upon reaching the objective, an ATKHC or air cavalry troop may be responsible for securing the air assault force from both aerial and ground enemy elements in the area of operations determined by the TF commander. If the objective is beyond the range of indirect fires, the aviation commander will have to plan to conduct SEAD using onboard weapon systems, ECM, ECCM, and detection avoidance. The ATKHC or air cavalry troop screens to provide reaction time and maneuver space for the main force. If the air assault TF mission requires that only a short time be spent on the objective, the assault aircraft may hold in an area close by the objective. This may require that the ATKHC or air cavalry troop protect the assault aircraft or a position or area between the ground force and screen line may be selected. Then the rear covering force will be the primary overwatch element during the exit.

b. Close Operations. Air combat in the close operations area will result from enemy attacks against the combined arms team (primarily air and ground antiarmor forces). This is particularly true when the enemy attempts to penetrate or flank friendly

FM 1-112

forces. Therefore, air combat will result as an outgrowth of the aviation units' primary mission to maneuver and support combined arms operations. While protection of the force may require air combat operations, air combat may also be the result of a meeting engagement, which will require the aviation force to engage in self-defense. To counter the air threat, aviation commanders may have to allocate a portion of their force to provide area security during close operations. This effort keeps maximum combat power directed against the ground forces and avoids surprise, disruption, and decisive engagement by the air threat.

(1) In planning the primary mission, the aviation company or troop commander needs to obtain information about friendly AD positions, WCS, and coverage areas. He uses this information to plan BPs, reconnaissance areas, security areas, and routes to and from them. When these positions or areas are covered by friendly ground-based AD assets, the aviation company commander must know their status and capabilities and task-organize accordingly. In all situations, especially when there are no ground-based AD assets, the commander plans for area security and uses available attack or air cavalry forces and preplanned fires throughout the mission.

(2) Mission planning for assault aircraft operating on the friendly side of the FLOT must also include AD coverage information. The AMC uses this information to plan flight routes to and from the mission area. He must plan to stay inside the AD-protected areas of coverage as much as possible and to use weather and terrain to his best advantage. All aircraft must use flight routes, terrain flight techniques, reduced visibility, and smoke and ECM to reduce possible detection by enemy aircraft and AD systems. Detailed planning, reliable intelligence, aircraft early-warning systems, lookout techniques, and terrain flight will maximize US strengths and degrade enemy capabilities.

(3) Attack platoons or scout-weapons teams seek to remain undetected, to perform their primary missions, and to enhance survivability from direct fire threats. Commanders select attack and observation positions that provide concealment from enemy helicopters. The use of shadows and the sun is a prime consideration in site selection. Observation posts are positioned to give sufficient early warning and to ensure that the main force has adequate reaction time and maneuver space. To preclude attracting unnecessary attention, all aircraft moving into, within, and out of BPs must use covered and concealed routes.

(4) Air cavalry and attack helicopter units use traveling, traveling overwatch, and bounding overwatch while flying to and from the mission area. If an air threat is encountered and subsequently engaged during movement, the overwatch element immediately suppresses it, depending on the factors of METT-T. The maneuvering element seeks terrain masking if the air threat is at a distance. If the air threat is within effective weapons range or if terrain masking is not available, the moving element will engage the air threat. The overwatch and movement elements continue to engage enemy aircraft until the primary mission is no longer threatened. Because of the potential

density of threat ADA systems and CAS aircraft in close operations, NOE fire and maneuver will be the primary method of engagement.

(5) While attack aircraft are in BPs, they concentrate on engaging ground targets. Security aircraft perform the primary mission of aerial security operations by overwatching the likely air avenues of approach that were determined in the IPB process. They occupy positions where they can cover enemy air avenues of approach into the combat area that friendly ground AD does not cover. Should they acquire an enemy aircraft approaching the BP, they will execute the stated battle drill (Appendix A). Rapid engagement of the most immediate threat is of greatest importance.

(6) Because of the Army NOE flight profile, aviation forces may have a considerable advantage in acquiring the air threat. Aircraft operating in an NOE environment take advantage of terrain masking and ground clutter. Threat aircraft operating at somewhat higher altitudes may silhouette themselves against the sky. When the defender capitalizes on first acquisition, he can grasp the initiative and go on the offense. This tactical flexibility is enhanced by the defender's knowledge of the terrain and by anticipated air threat actions.

(7) Based on the factors of METT-T, the aviation commander must evaluate the situation and decide whether to engage to destroy, engage to delay, or to avoid engagement. The mission of the aviation unit may also dictate this decision. The commander must not allow his forces to be surprised, divided, or decisively engaged.

c. **Rear Operations.** Air combat in rear operations occurs when the threat uses helicopters to disrupt friendly C², CS, and CSS activities. They will use these helicopters in both air assault and air attack roles. Army aviation has the necessary mobility and firepower to defeat rear area incursions. Corps and divisional aviation units may be given an on-order or primary mission to conduct rear operations. The best tactical solution for success is to defeat the enemy's air assaults or attacks before they can deliver troops or ordnance.

(1) Rear operations will be reactive; therefore, they must be aggressively executed. Aviation forces conducting rear operations must be positioned to react quickly, intercept, and engage enemy forces. To do this, aviation commanders will need real-time intelligence and early warning. Information, such as enemy objectives and likely air avenues of approach, must be derived from the IPB process. Planning and coordination for rear operations will include a detailed analysis of the area of operations for possible routes, corridors, and engagement areas.

(2) The rear operations center publishes the corps/division rear operations plan. The OPLAN contains tactical guidance and task-organization. It assigns missions to the various elements tasked to protect the rear area. This plan is normally transmitted in the form of an annex to the corps/division OPLAN or OPORD. This annex will provide the aviation unit that is tasked to conduct rear operations with the specific information

FM 1-112

required to develop its respective OPLAN such as unit locations and FS coordination measures.

(3) Air combat in rear operations will require extensive planning and coordination. To thoroughly plan for air combat contingencies in conjunction with rear operations, the aviation commander and his staff must--

- Understand the division/corps commander's priority of protection of critical rear area assets as stated in the rear operations OPLAN.
- Know the locations of all friendly elements within the rear area to prevent fratricide.
- Ensure that the aviation scheme of maneuver is integrated into the division/corps rear operations plan.
- Conduct a thorough IPB to determine likely air avenues of approach and probable threat targets.
- Ensure that C² functions and facilities that are peculiar to rear operations are established.
- Ensure that the unit is tied into the division/corps AD early warning network. Currently, this is the SHORAD warning net; however, in the near-term air threat, data will be provided by the FAAD C³I network.
- Coordinate with the division or corps A²C² element for holding areas, engagement areas, air routes, and BPs.

(4) The speed at which enemy helicopters can conduct rear area incursions will make acquisition distances and the timely flow of early warning information critical. Aviation forces must be tied into the early warning network with preplanned procedures and prebriefed actions on contact if effective intercepts or ambushes are to be executed.

(5) Aviation forces diverted from other missions and not already assigned an on-order air combat mission can be employed against the air threat. Their effectiveness is degraded because of--

- Possible incompatible weapons mixes.
- Insufficient time to plan and brief the mission.
- Distances to intercept points.

(6) Air combat operations are an implied mission for the attack of an en route enemy force. When the aviation unit is notified of an impending air assault or air

attack, aviation forces are deployed to positions along the likely air avenues of approach. Once threat aircraft are detected, the aviation commander selects the area of engagement from previously considered areas. He then moves his attack assets to BPs near the engagement area and ambushes the enemy air formation. FS is used to further disrupt enemy plans and to destroy enemy forces or cause the air threat to divert into AD or air combat engagement areas.

(7) Engagement techniques in rear operations will be consistent with those of close and deep operations with only a few differences. Aviation forces must ensure the best use of the combines arms team in the planning and execution of air combat operations. The effective use of combat multipliers can be decisive. Coordination and planning within the A²C² system, specifically the AD assets in the division/corps rear, can enable aviation forces to make the most of the battlefield air dimension.

F-9. BATTLE DRILLS

This paragraph discusses battle drills and their application to air combat operations. Battle drills--

- Are collective actions rapidly executed without applying a deliberate decision making process
- Are standardized to enhance the simplicity and efficiency of the maneuver.
- Are trained responses requiring minimal command direction and are performed by multiple elements.
- Are learned through academic and hands-on training. Meaningful repetition in training insures successful battle drills.
- Require minimal leader orders. Battle drills do not require extensive direction. Normally one or two words are sufficient to initiate key actions required by the drill.
- Apply to platoon or smaller units. The platoon or smaller element performs the drill as the foundation for follow-on actions that may be performed by a larger unit (company).

a. Fundamentals. Battle drills are standardized responses to a ground or air threat. The assumption is made in the drills that a two-aircraft element is the basic and most efficient maneuvering element. Movement of larger organizations should build on this base element.

(1) The drills are initiated by the first element (platoon or smaller unit) to observe the threat. Each drill is designed to respond to a threat approaching from a given direction. The primary objective of the drill is to warn the force so that the immediate response to the threat may be initiated. This objective includes moving the force from a

FM 1-112

position of disadvantage to a more advantageous position. The intent of the drill is to insure the survival of the force so that they may continue with and complete the primary mission.

(2) Army Aviation's immediate response to an air or ground threat consist of the **break** (left or right), **dig**, **split**, and **static** battle drills.

(a) The **break drill** allows friendly forces to respond to a threat approaching from right or left flank. Friendly aircraft turn to orient on the threat while maneuvering to avoid, evade, threaten, or engage.

(b) The **dig drill** is designed for an air threat approaching from ± 15 to the formation's general direction of flight. The primary objective of this drill is to separate friendly elements to avoid the threat or to cause the threat to concentrate on one element while the other friendly elements maneuver to a superior position.

(c) The **split drill** allows friendly forces to respond to a threat that approaches from the rear sector. The drill separates the elements of the platoon and turns and orients them on a threat that has approached from the rear sector. In most circumstances, aircraft performing the split drill will be responding from a position of disadvantage. That is, friendly forces have been seen or engaged by a threat approaching from the rear.

(d) The **static drill** is designed for friendly aircraft operating from a static position, such as a BP, or from a condition in which the platoon has minimal forward momentum, such as during screening operations.

b. Danger Area. Although not specifically designated as an air combat battle drill, the template shown in Figure F-1 depicts a danger area that applies to all drills. This area is representative of those situations where the appropriate drill must be performed. In some cases the threat may have suddenly appeared from behind a terrain mass and may preclude execution of a battle drill. In these situations, the only realistic response may be to deploy to cover or orient on the threat and shoot. Figure F-1 shows the criteria that would cause friendly forces to perform each of the drills.

NOTE: The detailed descriptions of the battle drills that follow include a common template that highlights when each particular drill is executed. A detailed response for each aircraft in the platoon is included. Finally, an illustration of the mechanics of each drill and the follow-on TTPs to demonstrate the movement of the following platoon is provided to aid in the understanding of the drill.

c. Alert Format. A critical element of the battle drill is the alert call. The call is transmitted by the crew first observing the threat. The call initiates a specific drill and cues a decision making process by the commander for the follow-on actions that will allow the force to avoid, evade, threaten, or engage the threat.

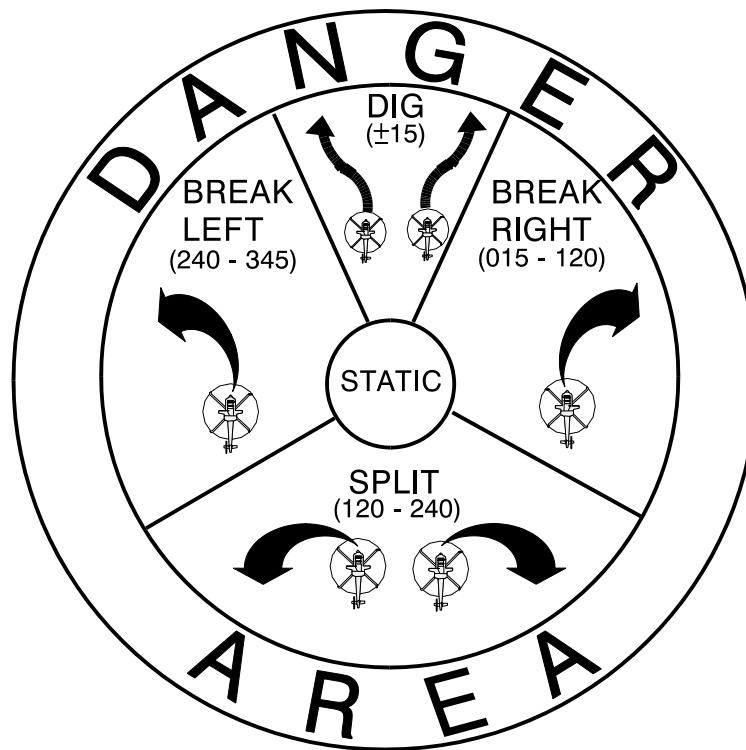

Figure F-1. Battle drill template

(1) The alert call consists of key words and phrases in a standard sequence as shown in Figure F-2. The first crew to observe the threat tells the remainder of the force his identification, what is observed (target, bandit, or bogey), the direction and distance to the threat, what drill is to be executed, and any other essential information.

(2) The other elements of the platoon respond to the alert and tell the element initiating the drill that they have either seen or not seen the threat and what their actions are. The follow-on platoon (if present) will perform the TTP directed by the commander to support the engaged platoon, bypass the engagement to continue with the mission, or mask to avoid the threat. Figure F-2 shows a battle drill action template.

d. Break Battle Drill.

(1) The break drill is used when the threat approaches from the right or left flank as shown in Figure F-3. The drill orients friendly forces on the threat and allows them to maintain visual contact while maneuvering to avoid, evade, threaten, or engage the threat.

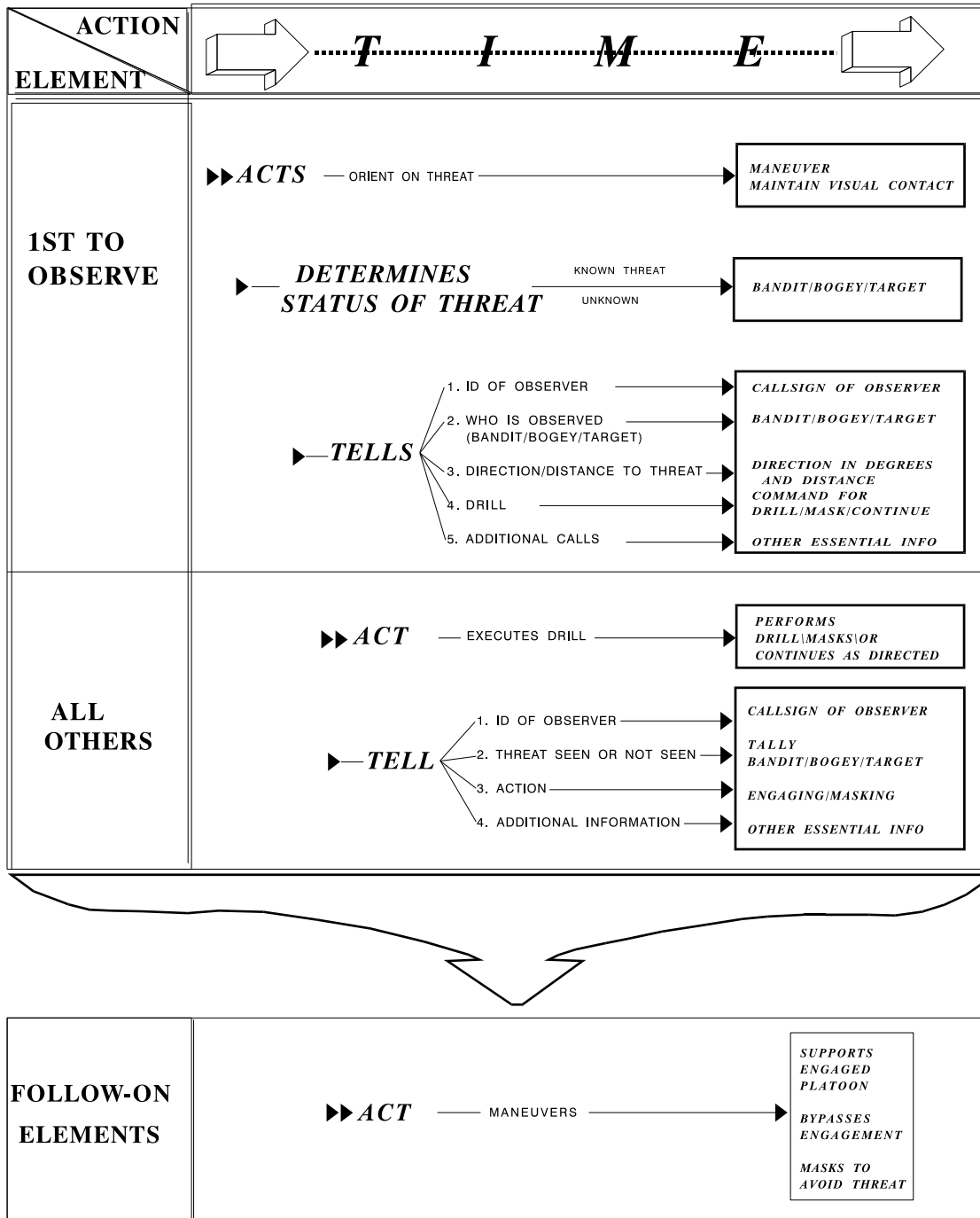

Figure F-2. Battle drill action template

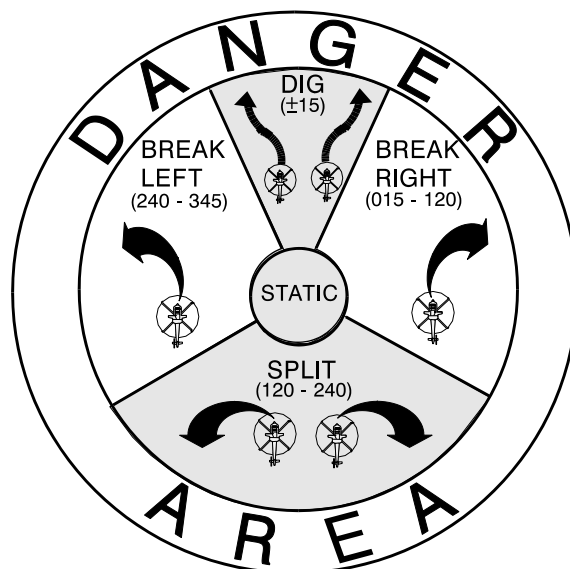

Figure F-3. Break battle drill template

(a) The friendly element that first observes the threat **acts** immediately by turning to orient on it. While maneuvering to orient on the threat, the friendly element will maintain visual contact and determines the risk posed by the threat. The friendly element determines whether the threat has seen friendly elements and has hostile intent. If the threat has not seen friendly elements or is not considered hostile, the desired COA is to avoid or evade the threat by masking or maneuvering away. To deter or destroy the threat if it is considered hostile, the friendly element first observing him will threaten or engage.

(b) When the threat is observed, the friendly element first observing the threat **tells** (alerts) the remainder of the force. The alert will include the identification of the element first observing the threat, what was observed (bandit, bogey, or target), direction and distance to the threat, action or drill required, and any other essential information. For example, "Gun 2, targets, 300 meters, break right, engage."

(c) If there is a requirement to execute a break drill, the alert will include "break right/left." The friendly element that first observed the threat directs the other friendly elements to perform a turn (break) in a specific direction (right or left) to either avoid being observed or to evade an attack by the threat. The friendly element making the call may break right with the other friendly elements or he may break left. His turn will be based on analysis of the threat's current actions and actions he determines he must perform to defeat the threat.

(d) Other friendly elements will **act** in response to the command issued by the element that first observed the threat. While using the information provided in the alert to locate the threat, they immediately break right/left as commanded. When the threat is located, the friendly elements will maintain visual contact while maneuvering to avoid, evade, threaten, or engage the threat.

(e) As they maneuver, the following elements will **tell** the element that initiates the battle drill if the threat has been located, what the friendly elements action is, and any other essential information. For example "Gun 1, tally 2 targets, engaging."

(f) Follow-on forces, such as a second platoon, maneuver as directed by the commander. They support the engaged platoon, bypass the engagement to continue with the mission, or mask to avoid the threat. Figure F-4 shows the actions of the friendly elements performing the break battle drill and those of the follow-on unit.

(2) Figures F-5a through F-5c show examples of a company of attack helicopters task organized into two platoons performing the break battle drill. The sequence shows the actions of the lead (engaged) platoon and those actions directed by the commander of the follow-on platoon to support the engagement.

e. **Dig Battle Drill.** The **dig** drill is used when the threat approach is from a sector ± 15 degrees to the formation's general direction of flight as shown in Figure F-6. If the friendly forces have not been observed, this drill allows them to separate to avoid the threat. If friendly forces have been seen and a threat engagement is imminent, the dig drill forces the threat to concentrate on one target while other elements in the formation maneuver.

(1) The friendly element that first observes the threat **acts** immediately by turning 30 to 45 degrees to the outside of (away from) the formation's direction of flight. While maneuvering to increase the separation between the elements of the formation and attempting to avoid observation, the friendly element maintains visual contact with the threat and **determines the status of the threat**. That is, the friendly element determines if the threat has seen the friendly elements and if the threat is hostile or not hostile.

(2) When the threat is observed, the friendly element that observed the threat **tells** (alerts) the rest of the force. The alert includes the identification of the element that first observed the threat, what was observed (bandit, bogey, or target), direction and distance to the threat, the action or drill required, and any other essential information. For example, "Gun 1, targets 360, 5,000 meters, dig".

(3) If friendly elements have not been seen or if the threat is not considered hostile, the desired course of action is to avoid or evade the threat by masking or increasing the lateral separation between friendly elements and the threat. Once the drill has been executed, the formation resumes their original heading. Once clear of the

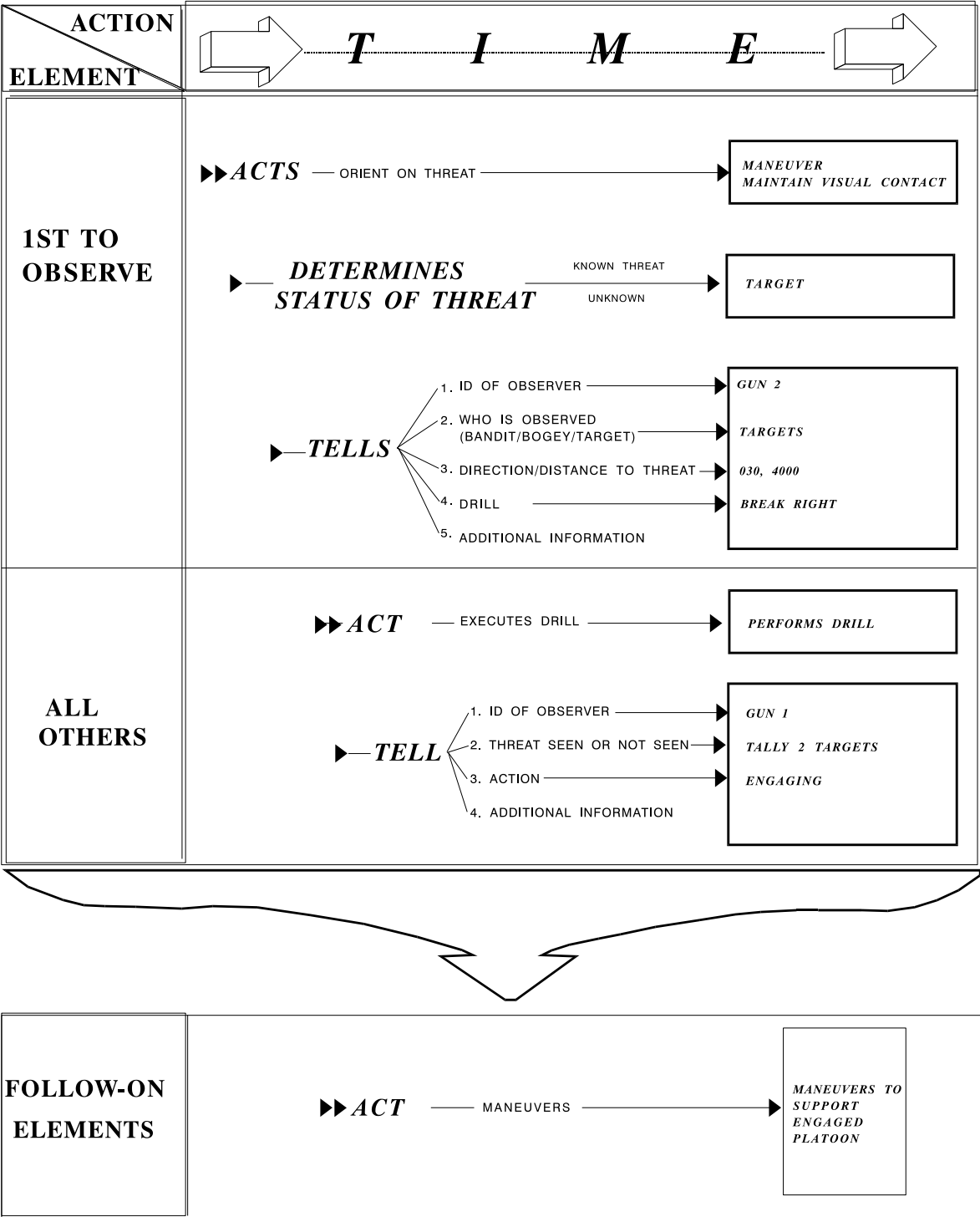
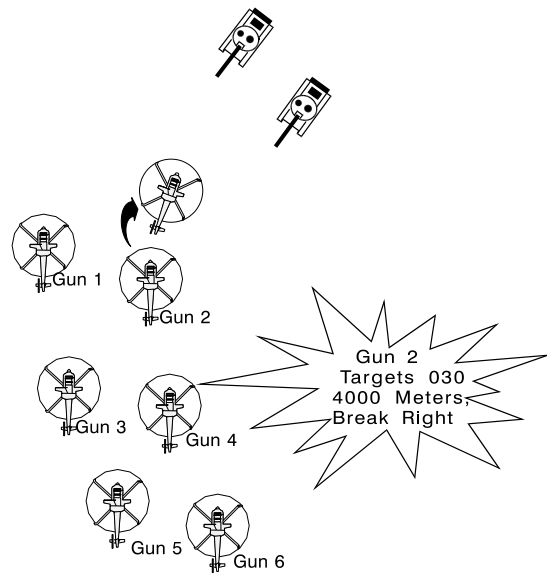

Figure F-4. Break battle drill action template

Gun 2 of the lead platoon sees attacking targets at 030 degrees.

He *acts* (turns and orients on the threat) and *determines* the threat's intentions.

As Gun 2 maneuvers to cover to engage the threat, he *tells* (alerts) the rest of the platoon and the follow-on platoon



(A)

Figure F-5a. Example break battle drill

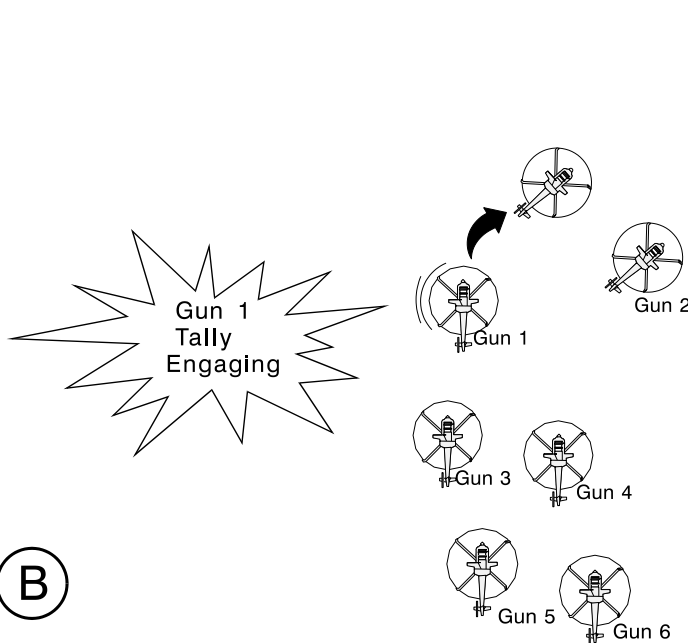

(B)

Gun 1 *acts* (immediately maneuvers to a vantage position and engages the threat to cover Gun 2).

He *tells* Gun 2 and the remainder of the company that he sees and is engaging the threat.

Figure F-5b. Example break drill (continued)

The 2nd platoon leader hears Gun 2's alert call. He executes a hook right to place his platoon in a position to support 1st platoon.

©

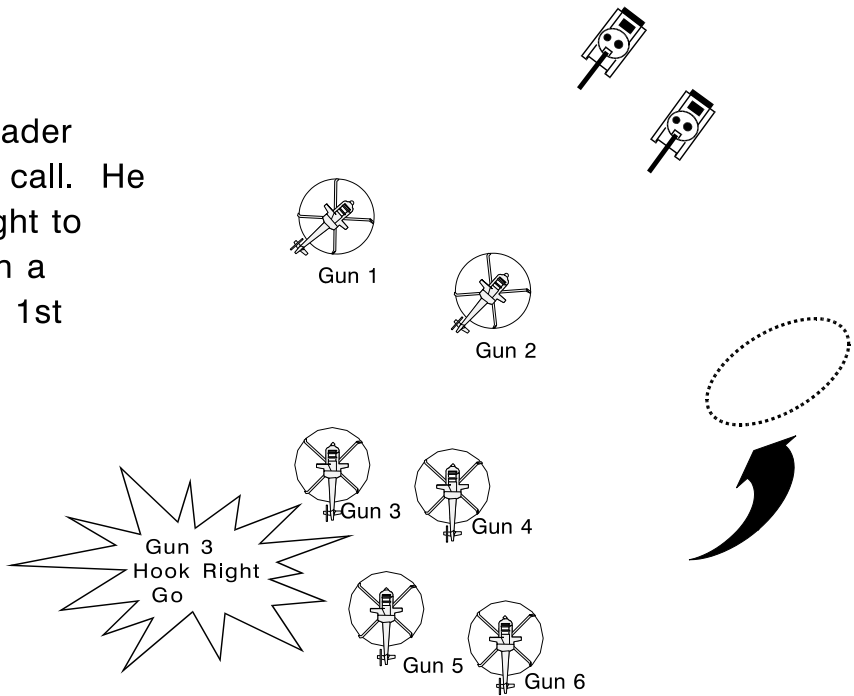

Figure F-5c. Example break battle drill (concluded)

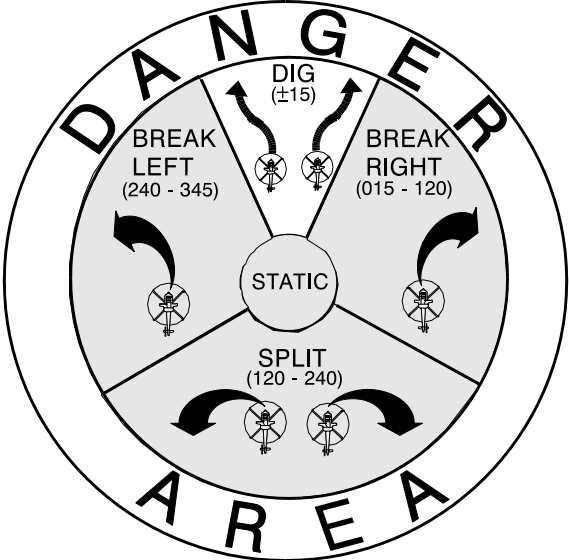

Figure F-6. Dig battle drill template

FM 1-112

threat, the formation performs a pinch maneuver to close the lateral separation between flight elements. Figure F-7 shows how, using dig and resume maneuvers, to increase and decrease lateral separation between formation elements to avoid being seen by the threat.

(4) If the threat has seen the friendly forces and is maneuvering to engage, the friendly element under attack turns to orient on the threat and maneuver as it deploys to cover and engages the threat. Other team elements **act** in response to the alert issued by the first element. Team elements turn 30 to 45 degrees to the outside of (away from) the formation's direction of flight and follow resume and dig commands to maintain the formation's lateral spacing. Figure F-8 shows friendly elements responding to hostile threat tanks.

(5) The platoon not engaged responds to the alert of the aircraft that first observes the threat and maneuvers as directed by the commander. They may **dig** in an attempt to increase lateral separation and **avoid** being observed if the threat is passing through the forward platoon, they may perform a **hook left** or **hook right** maneuver to support the forward platoon if the forward platoon is engaged. After considering the factors of METT-T, the commander may perform any other maneuver he considers appropriate to either engage the threat or bypass depending on the mission. Figures F-9a and F-9b show the actions of the 2nd Platoon during a dig drill.

(6) The actions of the friendly elements performing the dig battle drill and those of the follow-on unit are summarized in Figure F-10.

(7) Figures F-11a and F-11b give examples of a company of attack helicopters, task organized into two platoons, performing the dig battle drill. The sequence shows the actions of the lead platoon engaged by the threat and the actions the commander of the follow-on platoon directs to support the engagement.

f. Split battle drill. The **split** drill is used when threat approach is from approximately 120 to 240 degrees to the formation's direction of flight (Figure F-12). The drill separates the elements of the platoon and turns and orients them on a threat that has approached from the rear sector. If friendly forces have been seen and a threat engagement is imminent, the split drill forces the threat to concentrate on one target while other elements of the formation maneuver to a flank position to engage the threat.

(1) The friendly element that observes the threat **acts** immediately by turning approximately 180 degrees to the outside of (away from) the formation's direction of flight. While maneuvering to increase the separation between the elements of the formation and attempting to avoid observation by the threat, the friendly element maintains visual contact with the threat and **determines the status of the threat**. That is, whether the threat has seen the friendly elements and whether the threat is hostile or not hostile.

Gun 1 observes a nonhostile threat at 360 degrees and gives the command to Dig to increase the lateral separation between the elements in the flight.

Both Gun 1 & 2 immediately turn 30-45 degrees away from each other.

When the friendly elements are clear of the threat, Gun 1 gives the command to resume.

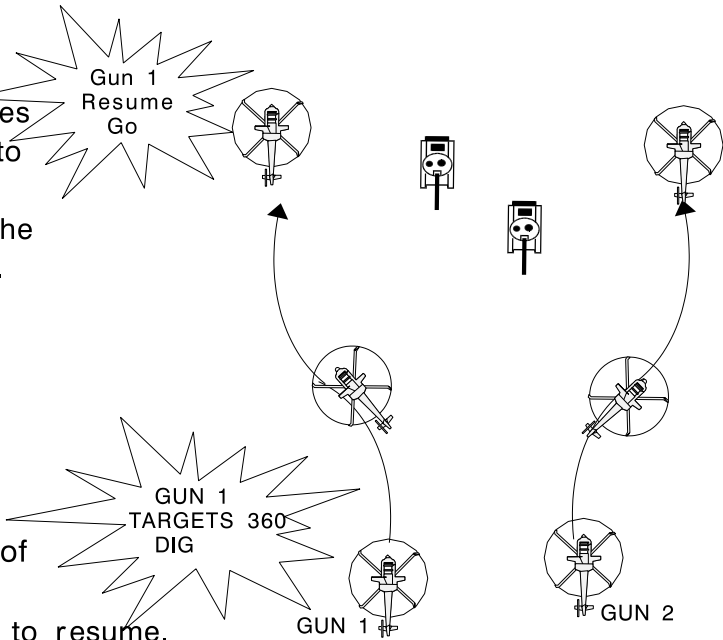

Figure F-7. Dig and resume used to avoid the threat

While performing the Dig, Gun 1 is engaged by the threat.

Gun 1 tells the other friendly elements that he is taking fire. He turns to orient on the threat while maneuvering to cover to engage the threat.

Gun 2 maneuvers to engage the threat from the threat's left flank.

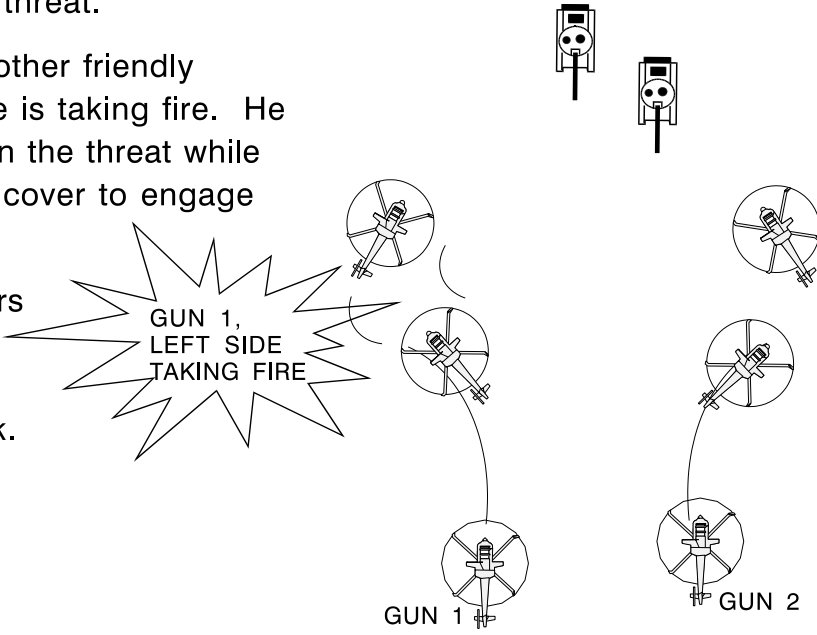

Figure F-8. Dig drill used to engage the threat

FM 1-112

The threat has not seen the forward elements passing.

Gun 1 tells all friendly elements that the threat is passing through the forward platoon's formation.

The 2nd platoon commander elects to perform a Dig maneuver to avoid the threat.

(A)

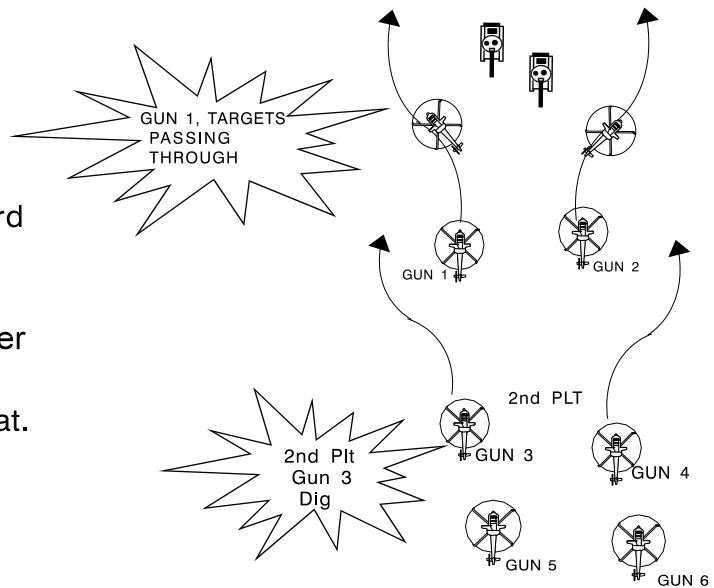

Figure F-9a. Actions of 2nd platoon (friendly elements not engaged)

Gun 1 is engaged by threat tanks.

The 2nd platoon commander maneuvers his platoon by performing a hook right into a firing position on the threat's left flank.

(B)

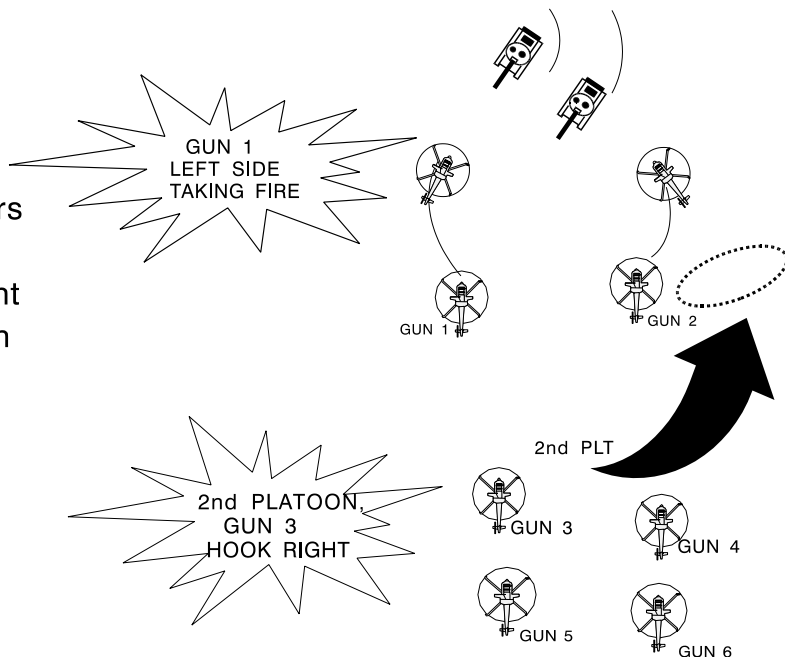

Figure F-9b. Actions of 2nd platoon (friendly elements engaged) (concluded)

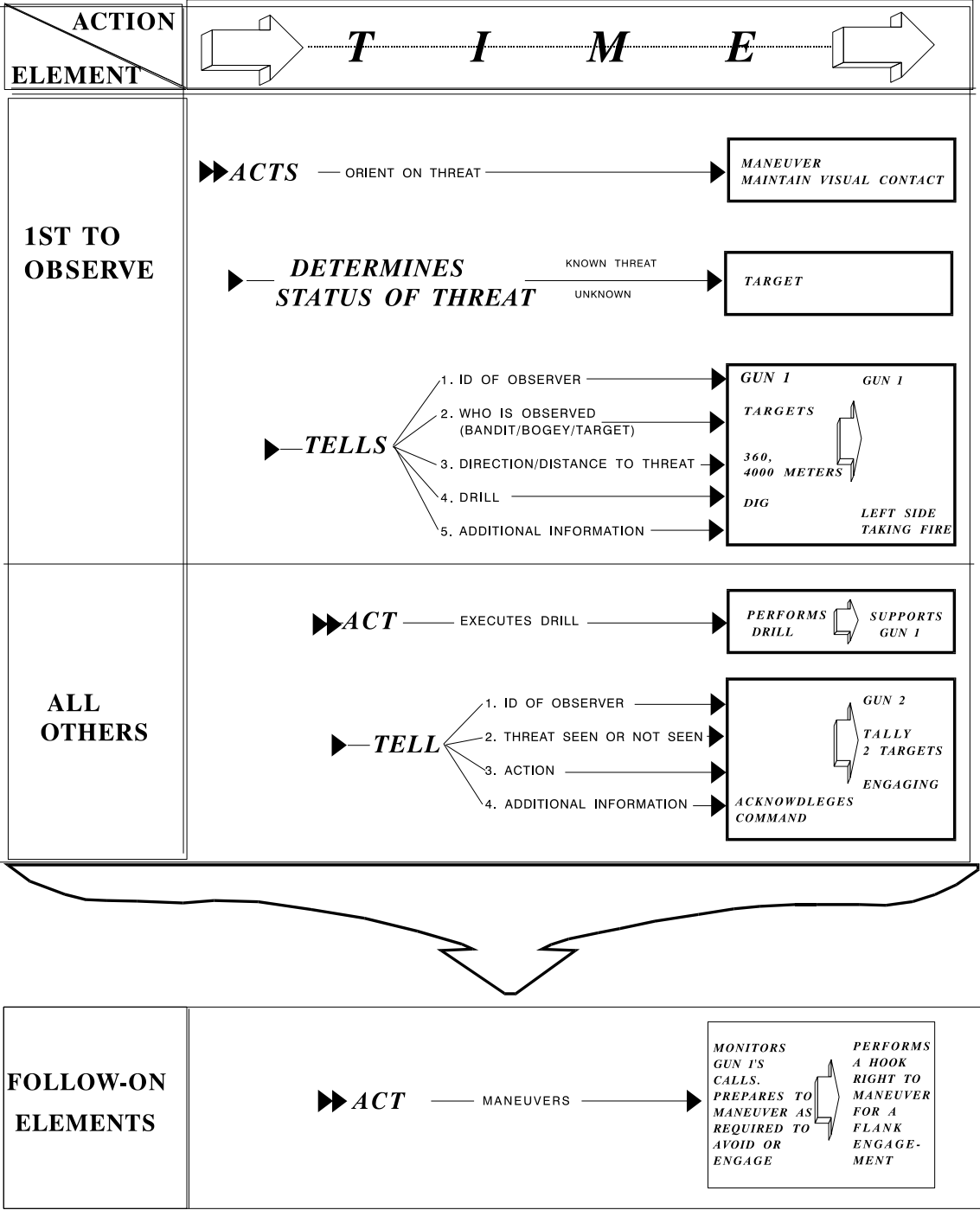

Figure F-10. Dig drill action template

Gun 1 of the lead platoon sees targets approaching from 360 degrees. He calls the Dig drill in an attempt to AVOID contact.

Gun 1 and Gun 2 turn 30 - 45 degrees away from each other to perform the Dig. As they begin the maneuver Gun 1 is engaged by the threat.

Gun 1 ALERTS Gun 2 and other friendly elements and turns to THREATEN and/or ENGAGE.

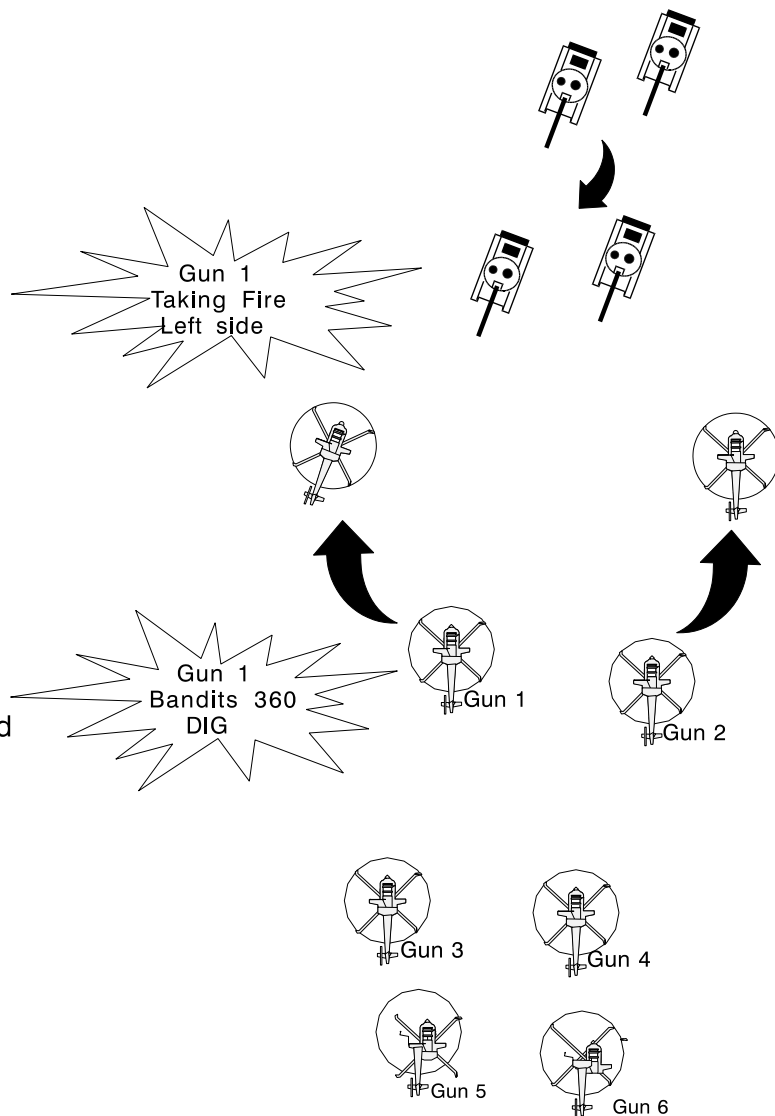

Figure F-11a. Dig battle drill (company task-organized into two platoons)

Gun 2 ACTS by responding to the initial call to execute the Dig drill.

Upon hearing Gun 1's second call, Gun 2 turns to orient on the threat and ENGAGES. Gun 2 TELLS Gun 1 that he has seen the targets and is acting to provide support.

The 2nd platoon commander ACTS in response to Gun 1's second call.

He calls a hook right to maneuver into a supporting position to engage the threat.

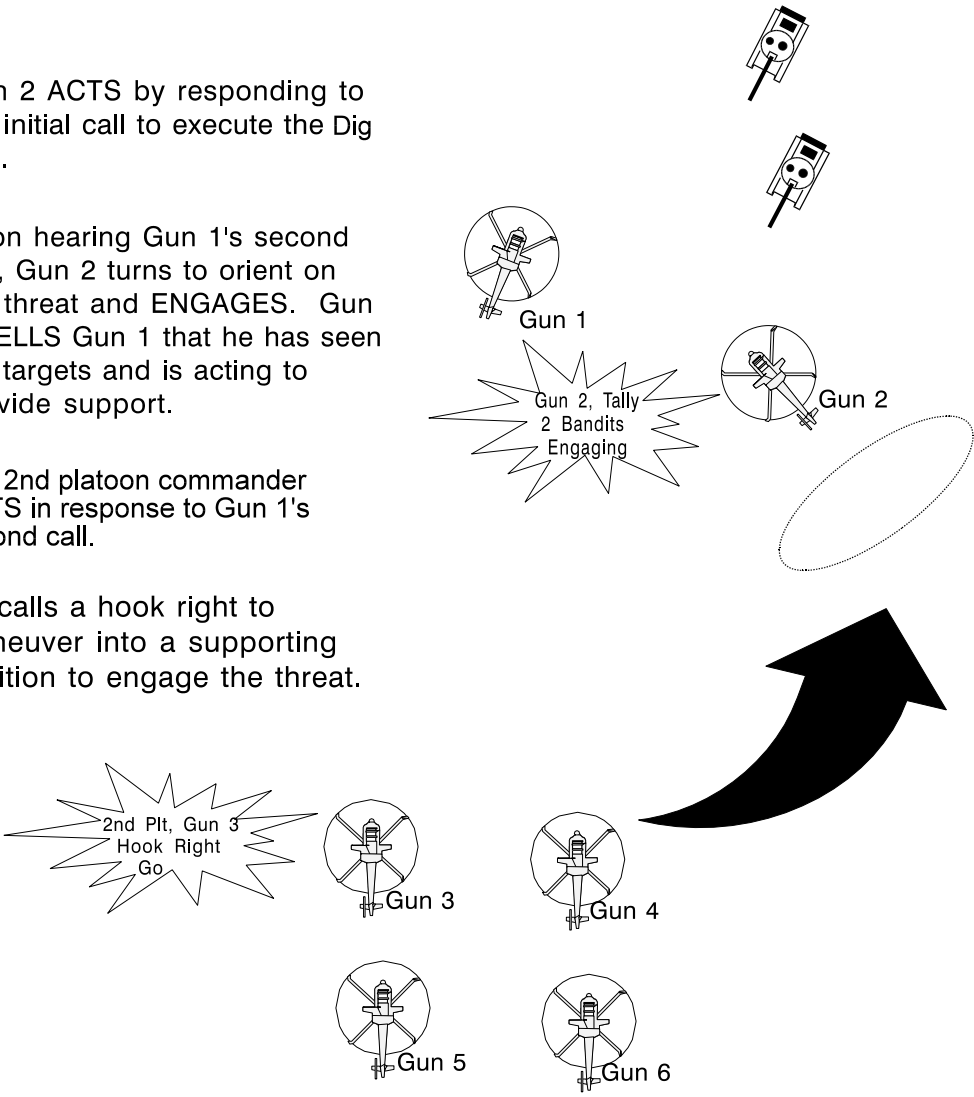

Figure F-11b. Dig battle drill (company task organized into two platoons) (concluded)

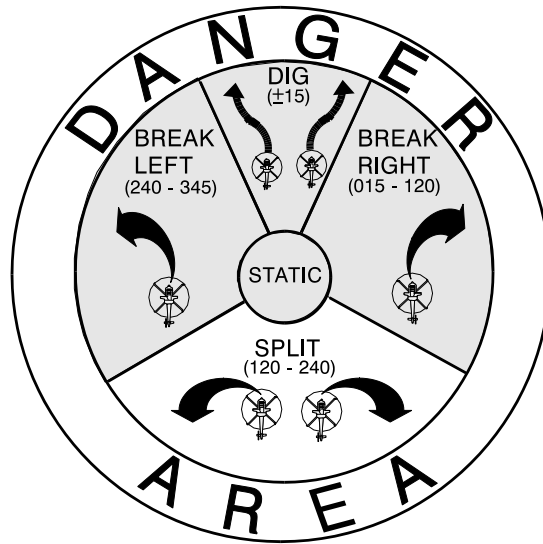

Figure F-12. Split drill template

(2) The friendly element first observing the threat will TELL (alert) the remainder of the force. The alert will include the identification of the element that first observed the threat, what was observed (bandit, bogey, and target), the direction and distance to the threat, action or drill required, and any other essential information considered essential. For example, "Gun 1, targets 180, 4,000 meters, split."

(3) If the threat has not seen friendly elements or is not considered hostile, the desired COA is to avoid or evade the threat by masking or bypassing the threat, if possible, while keeping visual contact with the threat. The dig maneuver may be used in this case to increase lateral separation between friendly elements and/or the threat until the friendly element is clear of the threat.

(4) Other friendly aircraft in the formation **act** in response to the command issued by the element that first observed the threat. They immediately turn approximately 180 degrees to the outside of (away from) the formation's direction of flight and establish visual contact with the threat (Figure F-13a and F-13b).

(5) If the threat has seen the friendly forces and is maneuvering to engage, the aircraft under attack turns to orient on the threat, maneuvers as he deploys to cover, and engage the threat. Other friendly elements in the formation maneuver as required to engage the threat. Figures F-14a and F-14b show friendly elements engaged by the threat while performing the split drill.

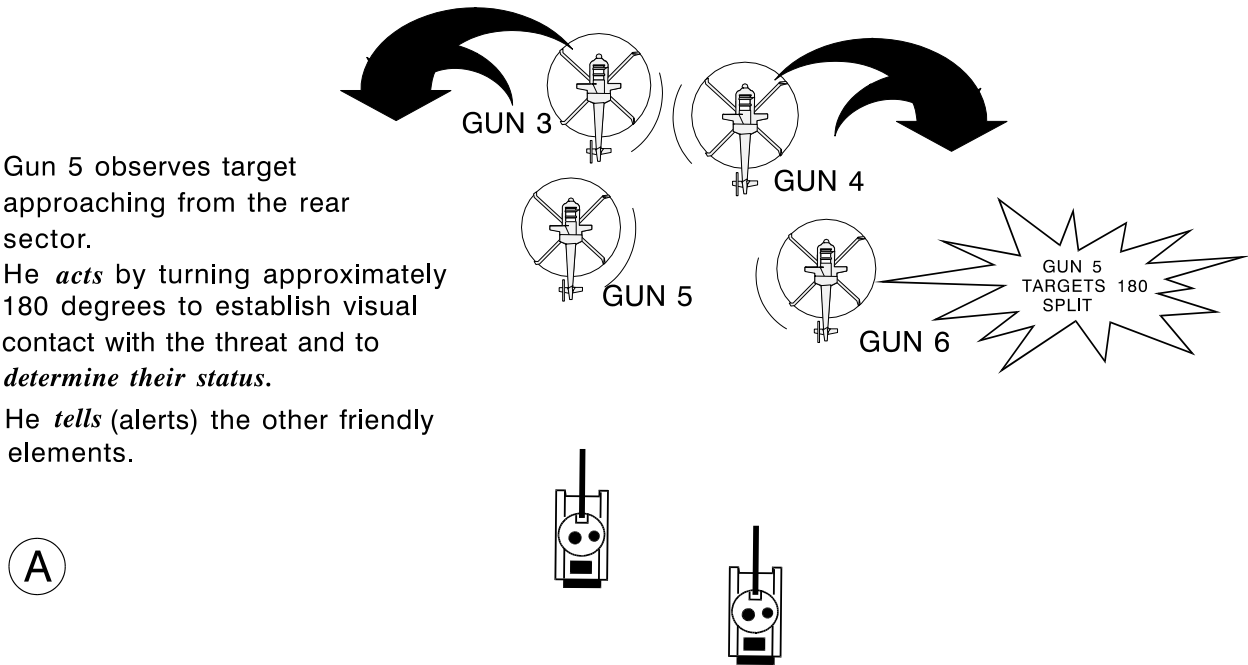

Figure F-13a. Friendly elements not observed while performing the split drill

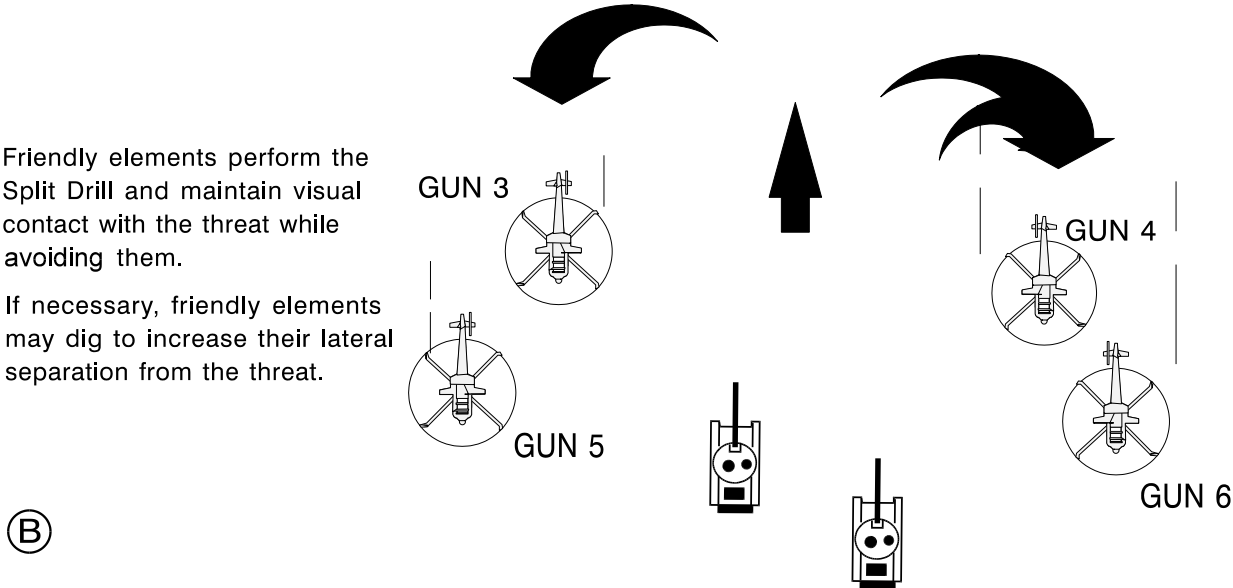

Figure F-13b. Friendly elements not observed while performing the split drill, (concluded)

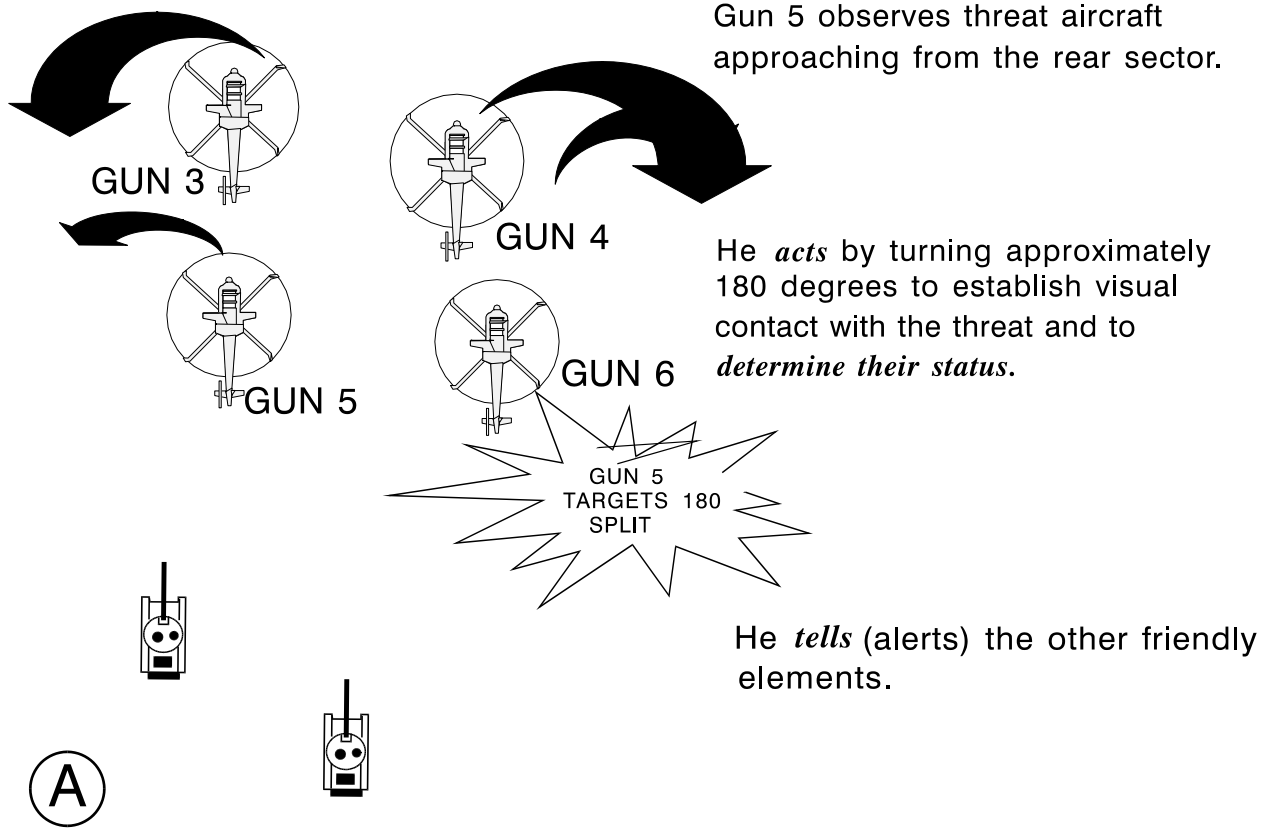
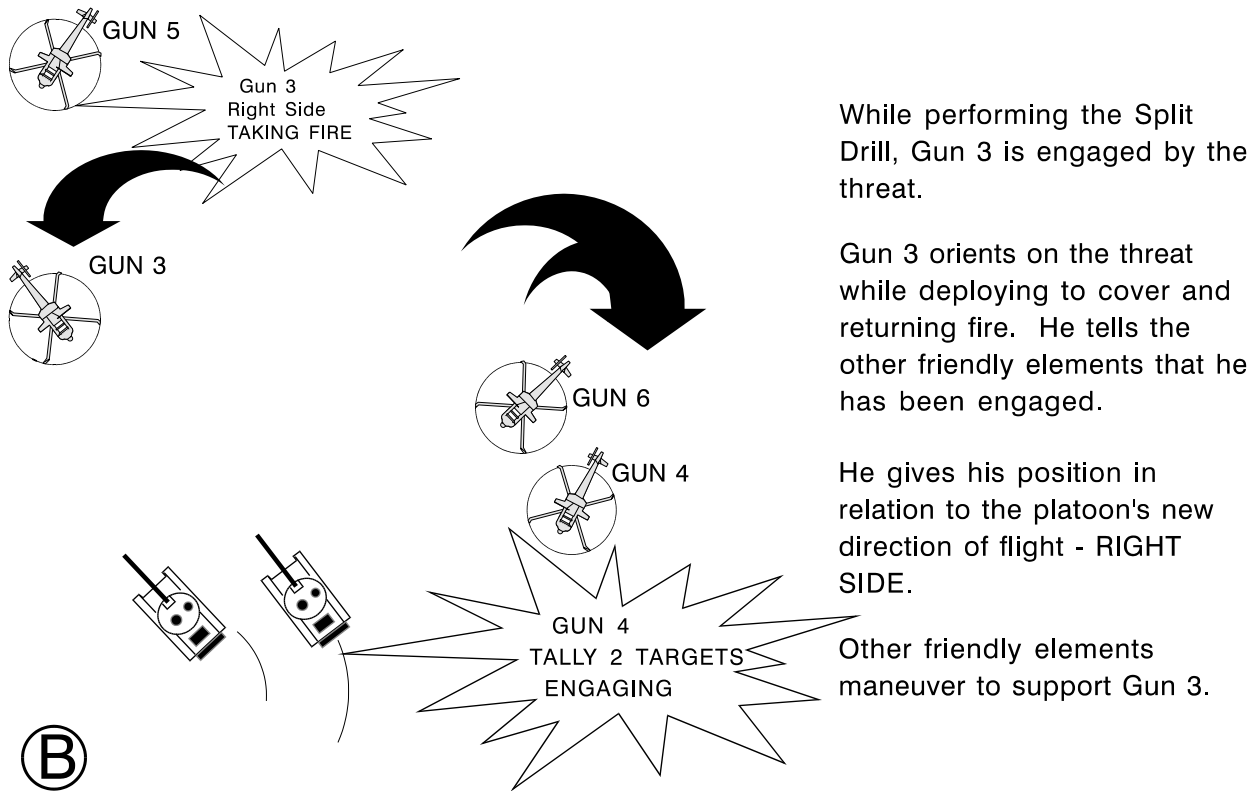

Figure F-14a. Friendly elements engaged while performing the split drill



While performing the Split Drill, Gun 3 is engaged by the threat.

Gun 3 orients on the threat while deploying to cover and returning fire. He tells the other friendly elements that he has been engaged.

He gives his position in relation to the platoon's new direction of flight - RIGHT SIDE.

Other friendly elements maneuver to support Gun 3.

Figure F-14b. Friendly elements engaged while performing the split drill (concluded)

(6) The platoon not engaged responds to the alert of the aircraft that first observed the threat and maneuvers as directed by the commander. The commander may elect any appropriate maneuver that allows him to orient his elements on the threat or, as a minimum, establish visual contact with the threat and provide support as dictated by METT-T. Figures F-15a and F-15b show the actions of the 2nd platoon during a split drill.

(7) The actions of the friendly elements performing the split battle drill and those of the follow-on unit are shown in Figure F-16.

(8) Figures F-17a and F-17b show an example of a company of attack helicopters, task organized into two platoons, performing the split battle drill. The sequence shows the actions of the rear platoon engaged by the threat and the actions directed by the commander of the lead platoon to support the engaged platoon.

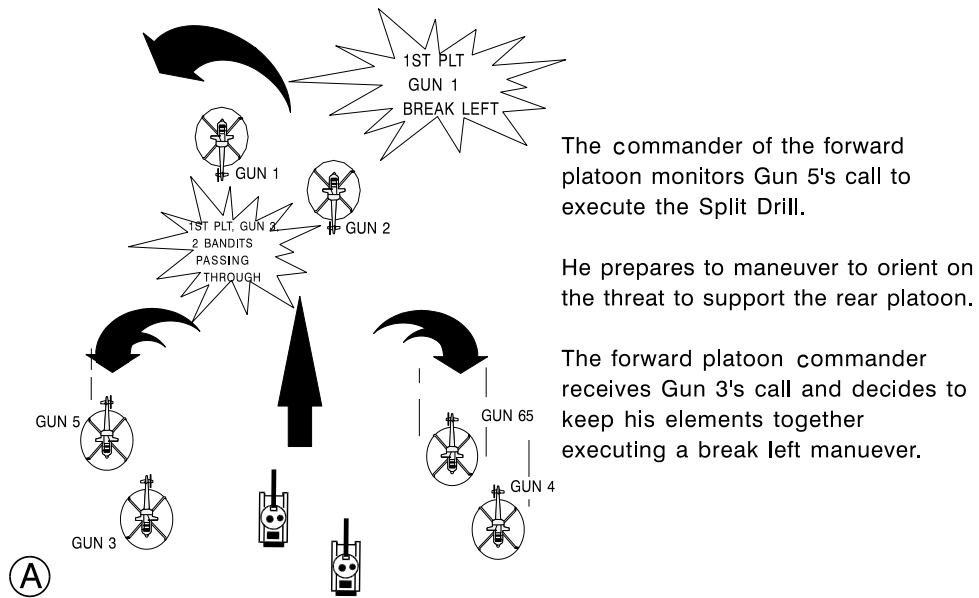

The commander of the forward platoon monitors Gun 5's call to execute the Split Drill.

He prepares to maneuver to orient on the threat to support the rear platoon.

The forward platoon commander receives Gun 3's call and decides to keep his elements together executing a break left maneuver.

Figure F-15a. Actions of 2nd platoon during split drill (friendly elements not observed)

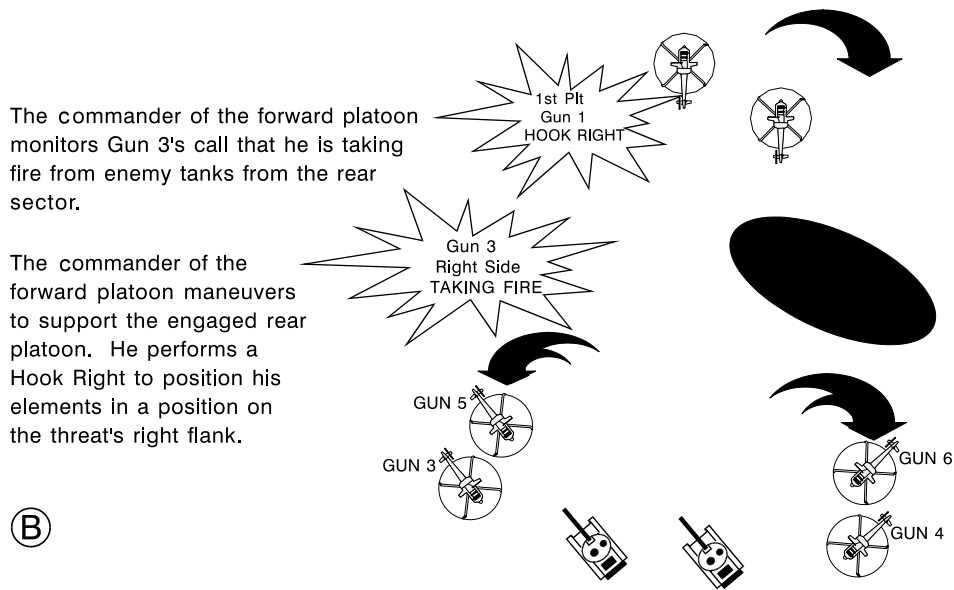

The commander of the forward platoon monitors Gun 3's call that he is taking fire from enemy tanks from the rear sector.

The commander of the forward platoon maneuvers to support the engaged rear platoon. He performs a Hook Right to position his elements in a position on the threat's right flank.

Figure F-15b. Actions of 2nd platoon during split drill (friendly elements engaged) (concluded)

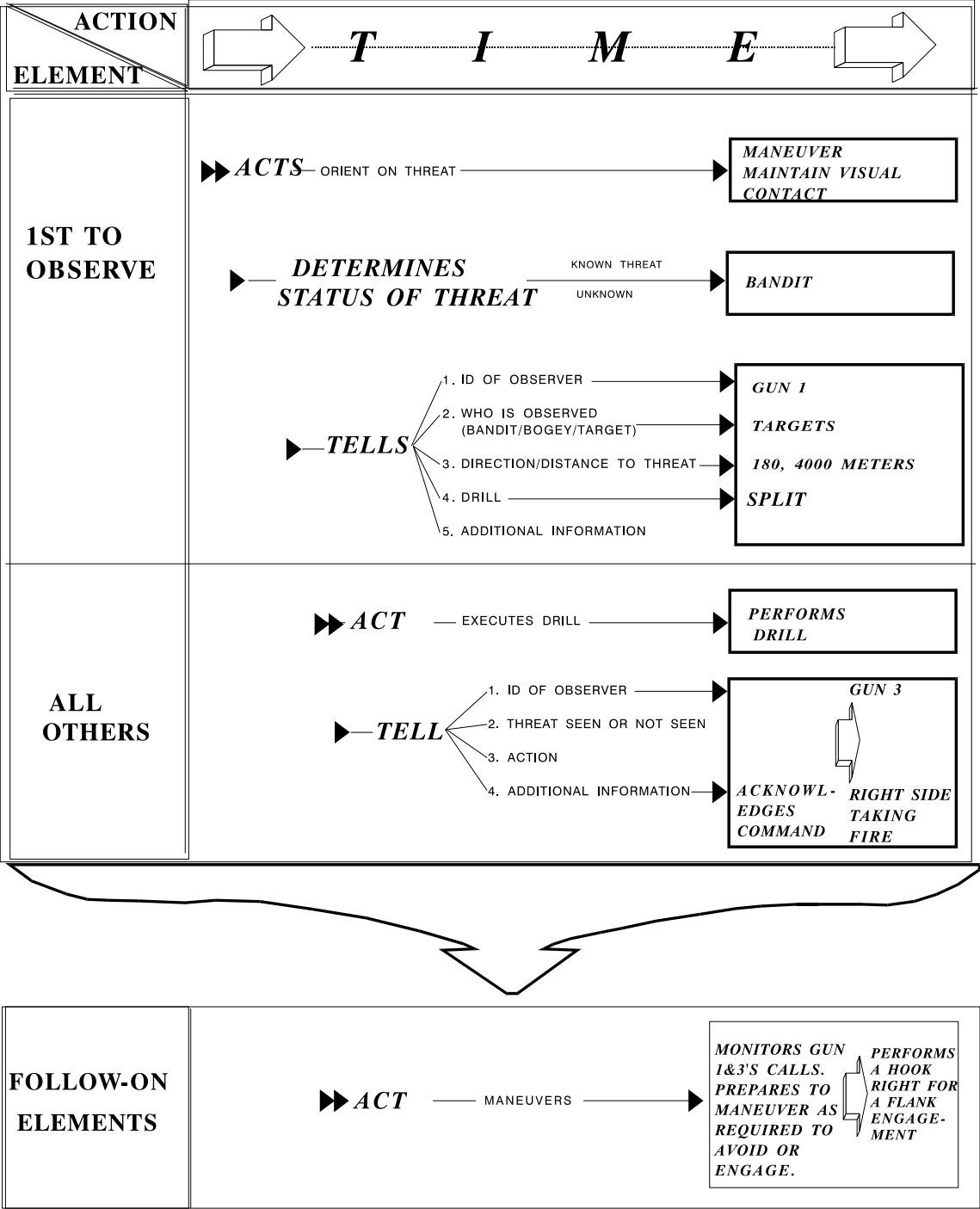

Figure F-16. Split drill action template

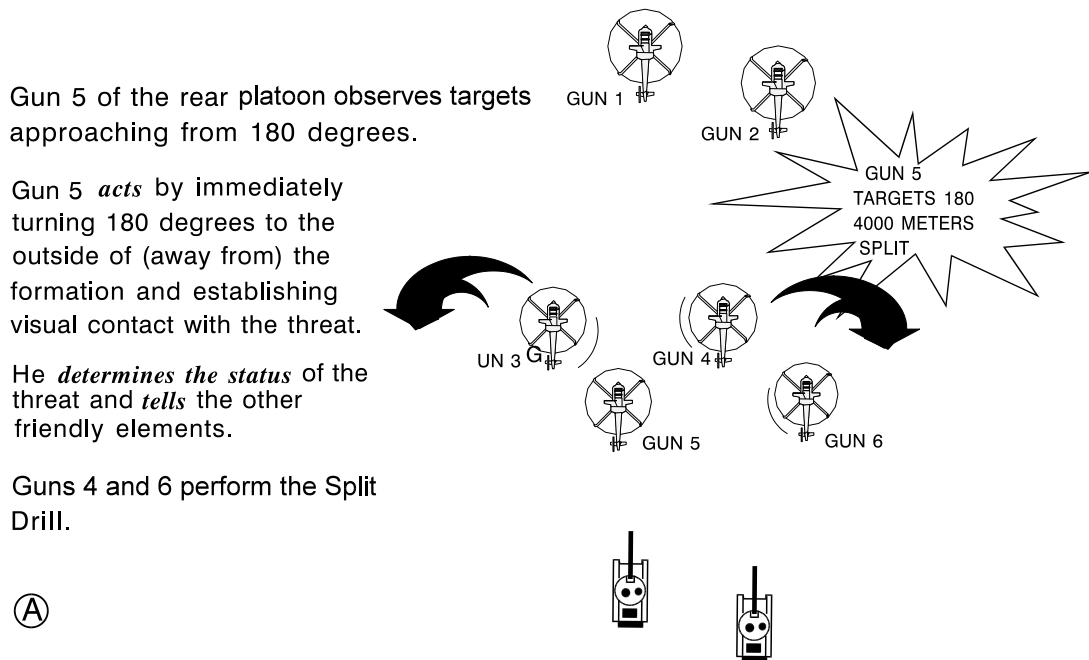

Figure F-17a. Example of a split battle drill

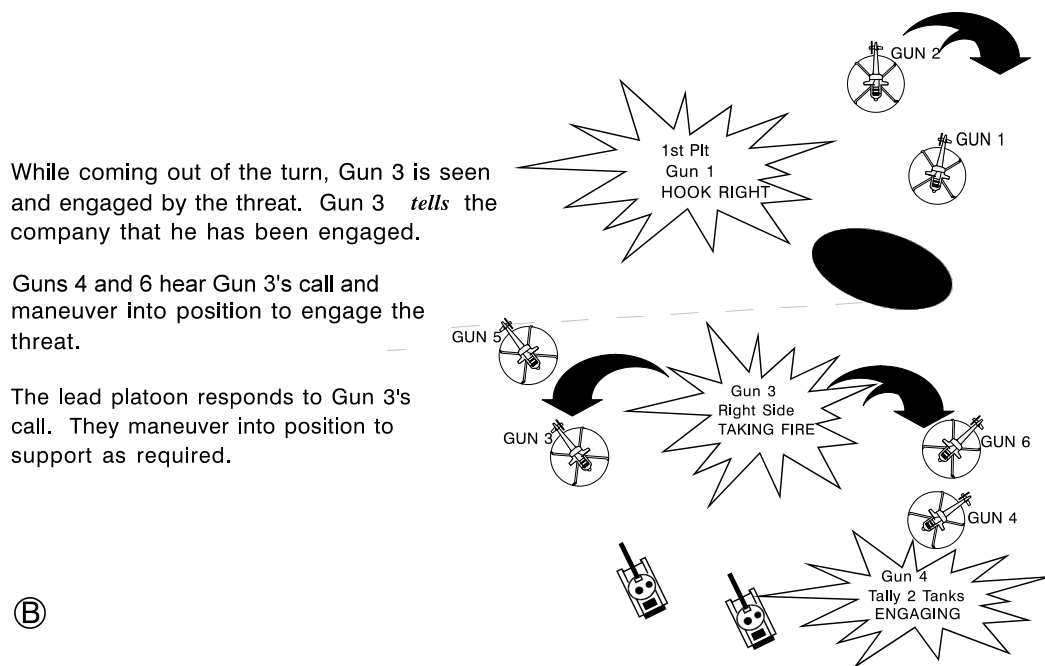

Figure F-17b. Example of a split battle drill (concluded)

g. Static Battle Drill. The **static** drill is used when friendly forces are not moving. For example, when conducting HA operations. It may also be used when the force is moving with relatively slow forward movement such as when conducting bounding overwatch or screening operations. The drill will allow friendly forces to respond to a threat approach from any direction primarily because of the deployment of forces to maintain local security. Figure F-18 shows the static drill in relation to the other drills.

(1) The security element that first observes the threat **acts** immediately by turning to orient on the threat. It maintains visual contact, **determines the status of the threat**, and **tells** (alerts) the rest of the force. The alert includes the identification of the element that first observed the threat, what was observed, the direction and distance to the threat, and any other essential information. For example, "Gun 2, targets 010, 5,000 meters, engaging."

(2) Other friendly aircraft **act** in response to the alert issued by the first element to see the threat and attempt to establish visual contact with the threat. The second element to see the threat orients on the threat and prepares to engage to protect the remainder of the force. This element **tells** other friendly elements that it has established visual contact with the threat and what its actions are. As the situation develops, the commander may designate additional friendly elements to protect the force. Other friendly elements assess their vulnerability to the threat and either continue engaging enemy ground forces, engage the threat in self defense, or reposition and deploy to cover. The actions of the friendly elements performing the static drill are shown in Figure F-19.

(3) Figures F-20a through F-20c show examples of a company of attack helicopters executing a static battle drill while performing BP operations. The sequence shows the company engaging targets in EA TREAD from BP SLEDGE, a security element alerting the force, and other attack elements repositioning to reengage the ground threat.

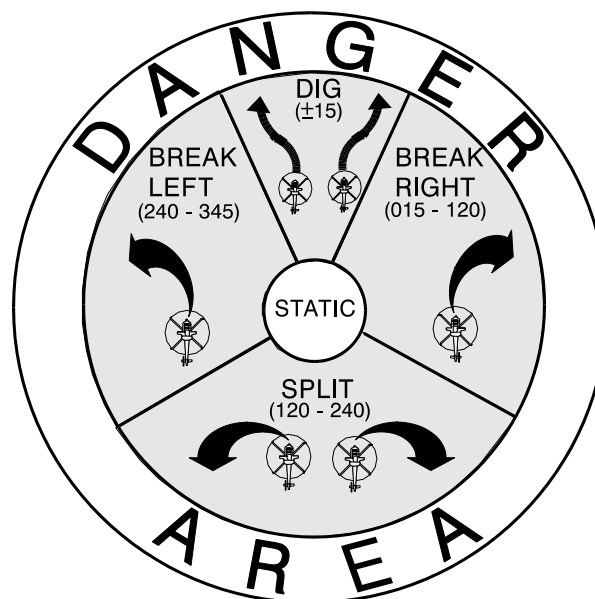

Figure F-18. Static drill template

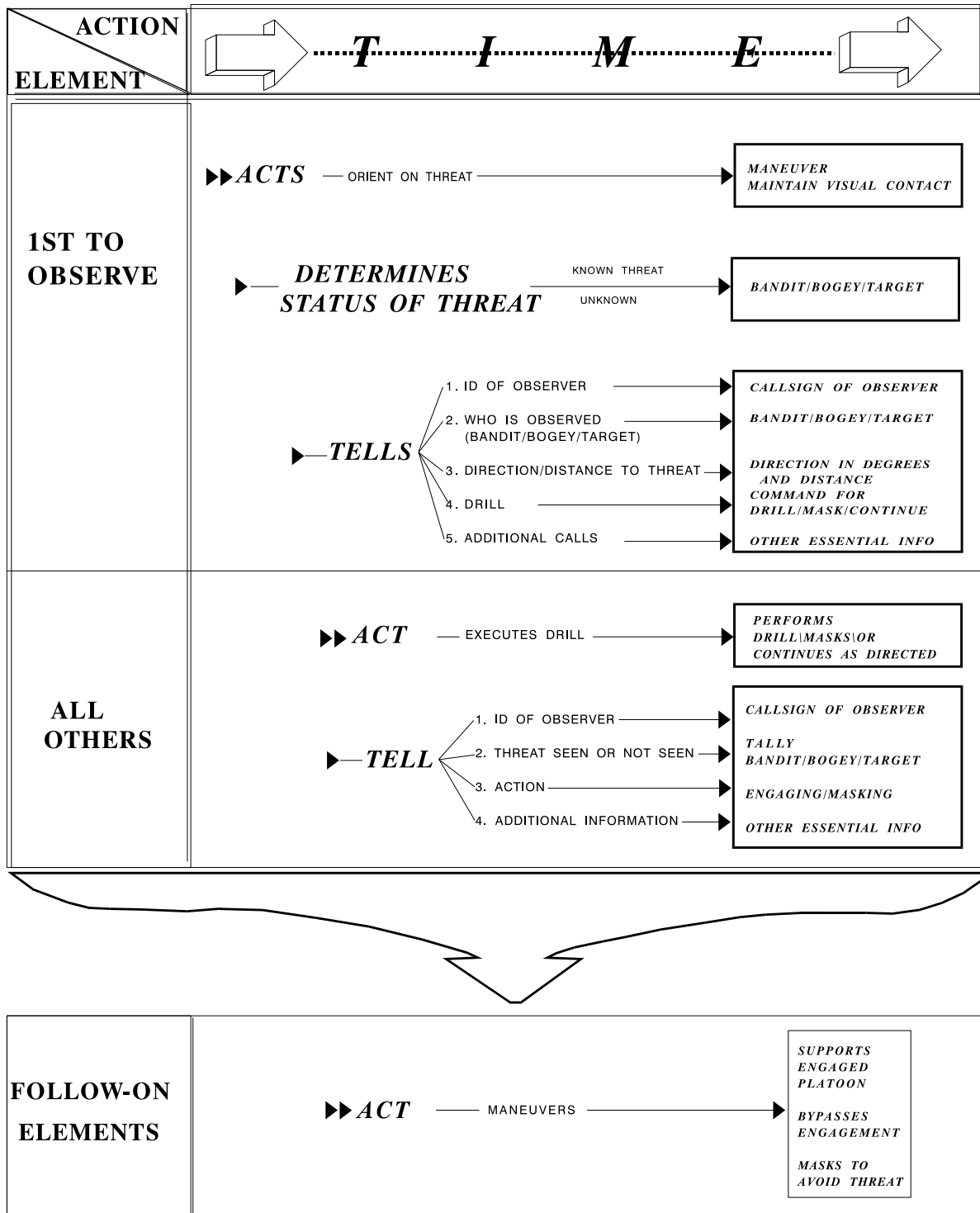

Figure F-19. Static drill action template

Gun 2, a security element, observes 2 targets approaching the BP.

Gun 2 *acts* by immediately turning to orient on the threat and establishing visual contact with the threat.

He *determines their status* and *tells* (alerts) the remainder of the force.

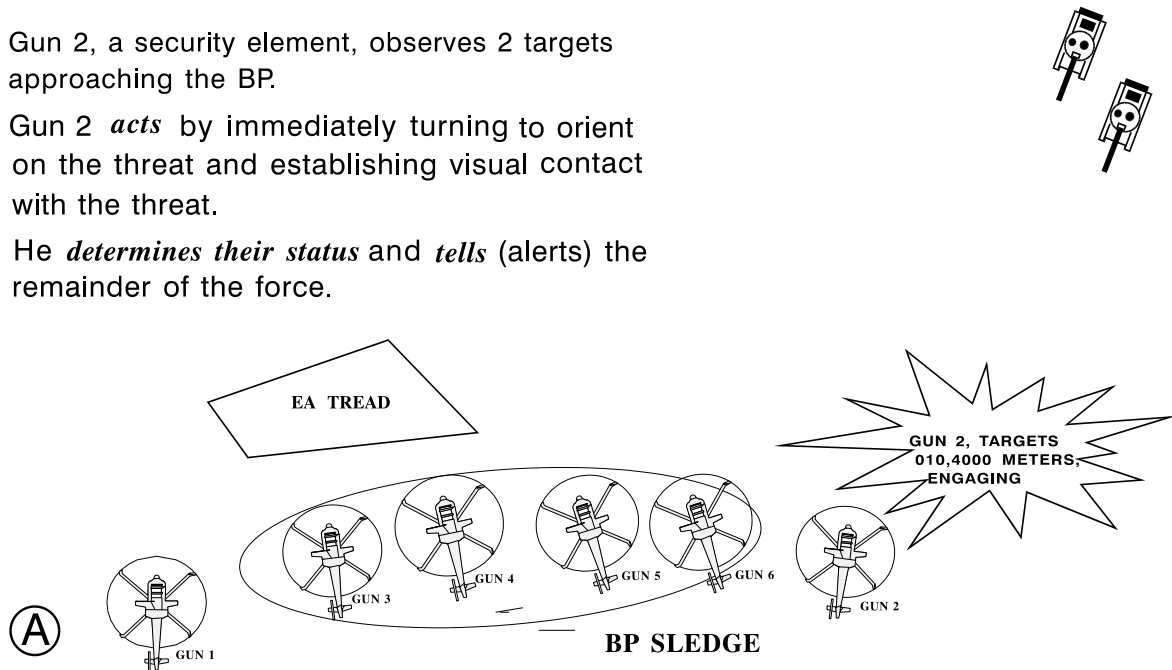

Figure F-20a. Example static battle drill

GUN 6 is the 2nd aircraft to see the threat.

He *acts* by turning to orient on the threat and prepares to engage the threat. He *tells* the remainder of the force that he has seen the threat and what action he is taking.

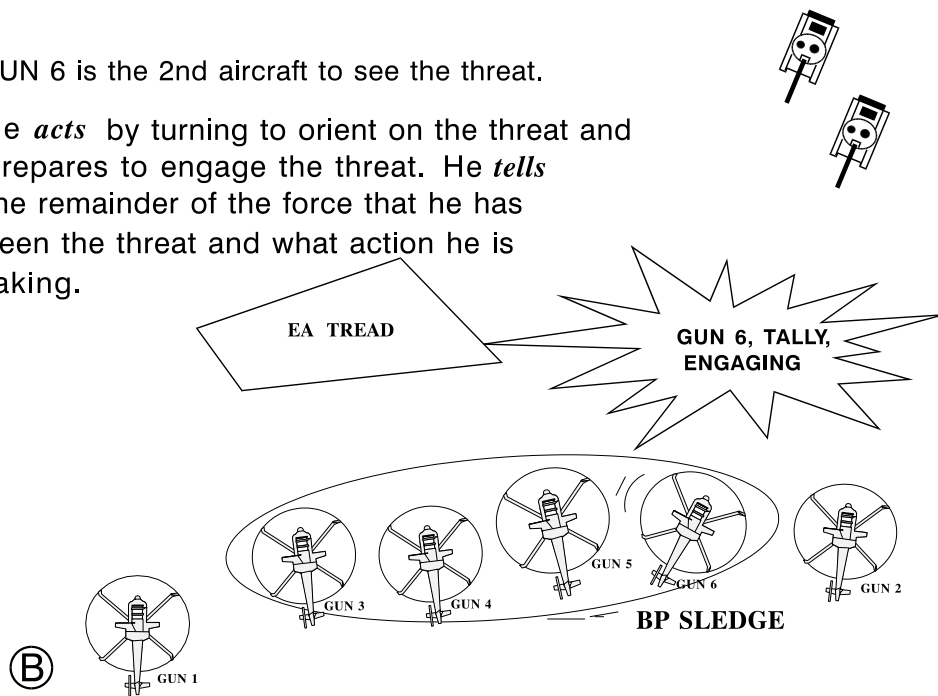

Figure F-20b. Example static battle drill (continued)

The other friendly elements assess their position. They continue engaging threat armor if they are not threatened or take evasive action if engaged.

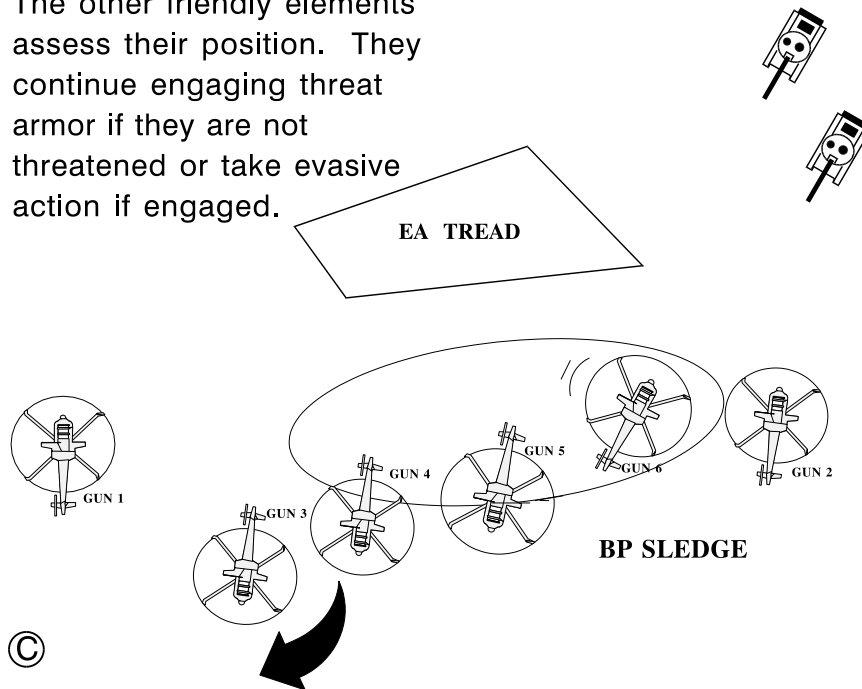

Figure F-20c. Example static battle drill (concluded)

F-10. TERMS

- avoid** A stated intent to maneuver away from a potential engagement with threat aircraft.
- bandit** An identified enemy aircraft.
- bogey** An unidentified aircraft that is assumed to be the enemy.
- break** An action command (normally preceded by the term bandit or bogey) to perform an immediate maneuver to deviate from the present ground track. Will be followed by "right" or "left" in response to a threat approaching from 015 to 120 degrees or 345 to 240 degrees of the direction of flight.
- center turn** An inward turning maneuver that results in a heading change of 120 to 240 degrees.

FM 1-112

| | |
|----------------------|--|
| check turn | A crossing maneuver that incorporates 30 to 60 degrees of heading change and repositions the wingman to the opposite side of the lead and vice versa. |
| dig | A maneuver that increases the lateral separation of a formation by simultaneously changing the headings of the aircraft 30 to 45 degrees away from each other or the axis of advance. When dig is preceded by the term "bandit" or "bogey," it becomes an action command to perform an immediate maneuver in which the members of the flight turn 30 to 45 degrees from each other in response to a threat approaching from ± 15 degrees of the direction of flight. |
| friendly | A contact positively identified as friendly. Is followed by the word "air" or "ground." |
| hook | A turning maneuver of an unspecified number of degrees to orient on an enemy aircraft for a flanking engagement. Is followed by the word "left" or "right." |
| in-place turn | A turning maneuver that turns a formation a designated number of degrees while each aircraft maintains its position in the flight. |
| no joy | A target (bandit or bogey) not observed. |
| padlock | A command issued to an aircraft or aircrew member to maintain visual contact with an enemy. |
| pinch | A maneuver used to decrease the lateral separation of a formation by simultaneously changing the aircraft heading 30 to 45 degrees toward each other. |
| resume | A command to resume or return to the original heading. Is normally used with dig and/or pinch. |
| splashed | Enemy aircraft shot down. Is followed by the number of enemy aircraft; for example, "Splashed two bandits." |
| split | A maneuver that turns the aircraft in a formation away from each other using a heading change of 120 to 240 degrees. Also, when split is preceded by the term "bandit" or "bogey," it becomes an action command to perform an immediate maneuver in which the members of the flight turn 120 to 240 degrees from each other in response to a threat approaching from 120 to 240 degrees of the direction of flight. |

| | |
|--------------------------|--|
| tac turn | A maneuver that turns a formation 60 to 120 degrees and results in a change of relative position. Is followed by the word "left" or "right." |
| tally | Target visually sighted. Is followed by the number of targets observed. |
| taking fire | A member of the platoon or company is engaged by the threat. |
| visual(no visual) | Visual or no visual contact with other members of the platoon or company. Term may be used with other terminology to indicate a visual on other friendly aircraft not in your platoon or company; (for example, visual or no visual friendly). |

APPENDIX G

ASSEMBLY AREA OPERATIONS

G-1. DESIGNATION OF ASSEMBLY AREAS

a. **Assembly Areas.** An assembly area is the location where the ATKHB prepares for future operations, issues orders, accomplishes routine maintenance and completes resupply activities. The assembly area must be out of range of enemy artillery and be large enough for dispersion of the unit. Assembly areas are normally located in the corps or division rear area and in or near the aviation brigade assembly area. However, corps and division aviation brigade assets may be dispersed over large areas to avoid becoming lucrative nuclear or chemical targets. Assembly areas must not be located along the enemy's axis of advance. An assembly area must also provide--

- Security.
- Concealment.
- Accessibility to MSRs.
- Air avenue of approach.
- Proximity to friendly units.
- Suitable ingress and egress routes.

b. **FAAs.** An ATKHB occupies FAAs for extended periods while awaiting orders to execute missions. FAAs are located near the controlling headquarters to improve C³I and response times. The FAA should be located out of range of enemy medium artillery. Limited maintenance personnel may be located in the FAA as contact teams jump forward to repair aircraft. Considerations for selecting FAAs are the same as those for selecting assembly areas.

G-2. OCCUPATION OF ASSEMBLY AREAS

a. **Assembly Area.** The assembly area is a battalion position. It is chosen based upon the mission of the battalion, the characteristics mentioned above, a map reconnaissance, and a physical reconnaissance of the selected area. Once an assembly area has been selected and coordinated, it is occupied when the mission for which it was selected is assumed. Occupation of the assembly area should be well planned and rehearsed. It is a four-phase operation. The phases are reconnaissance, quartering party arrival, main body arrival (ground and air), and position improvement.

FM 1-112

(1) **Reconnaissance.** An area reconnaissance of the assembly area and the surrounding terrain should be accomplished as soon as possible. Items to be looked for on the reconnaissance include suitability of the area, NBC contamination, and signs of enemy activity. Upon completion of the area reconnaissance, observation must be maintained until the arrival of the quartering party.

(2) **Quartering party arrival.** The battalion CSM, HHC commander, or HHC first sergeant command the quartering party, which should consist of at least two persons from each company and representatives of the battalion headquarters. Before entering the assembly area, the quartering party conducts a ground reconnaissance to confirm the air reconnaissance, selects ground routes into each company position and establishes initial area security. When the ground reconnaissance is completed, quartering party vehicles enter the assembly area. The priority of tasks for the quartering party is to--

- Conduct reconnaissance (including NBC reconnaissance).
- Establish security.
- Install M-8 chemical alarms.
- Establish wire communications between the main CP location and company positions.
- Verify communications with higher headquarters.
- Initiate the local area defense plan.
- Select aircraft and ground vehicle locations.
- Prepare to meet and guide the main body.

(3) **Main body arrival.**

(a) **Ground.** The main body of the battalion will arrive in two parts beginning with the ground portion. When ground vehicles arrive, they are met by members of the quartering party who guide them along the selected routes to each company's position. The priority of tasks upon the closure of the main body is to--

- Establish security.
- Place observation posts on air and ground avenues of approach.
- Reestablish the main CP.
- Camouflage.

- Block high speed avenues of approach that are not being used by the battalion.
- Begin operations.

(b) Air. Battalion aircraft should arrive after the ground portion of the main body. When the aircraft arrive they should be positioned in predetermined locations selected by the advance party. The location of the aircraft should provide the maximum concealment that is available. Aircraft should not be congested or lined up. Aircrews should complete a postflight or through-flight inspection of their aircraft, report aircraft status and then assist with the establishment of the assembly area.

(4) Position improvement. The assembly area is continuously improved as time allows. Some key areas that require continuous improvements are field sanitation, ground obstacles, camouflage, maintenance, and living conditions. Continuous camouflaging must be conducted to reduce the radar, heat, noise, electronic, and visual signatures of the battalion.

b. FAA. The FAA is a battalion position occupied by battalion aircraft, the battalion TAC, and a minimum number of ground vehicles. Planning for the occupation of the FAA is not as detailed as that required for the occupation of an assembly area. However, because the battalion may remain in the FAA for several hours, the commander and his staff must consider security and camouflage. Occupation of the FAA is a three-phase operation. These phases are reconnaissance, main body arrival, and security.

(1) Reconnaissance. An initial area reconnaissance (including NBC) of the FAA and the surrounding terrain is conducted. Upon completion of the area reconnaissance, a brief to the ATKHB commander or S-3 is conducted. The new position is kept under constant observation until the main body arrives.

(2) Main body arrival. Each company arrives at the FAA as a separate unit and lands in its predetermined area. Normally, the battalion staggers the arrival of its companies by allowing several minutes to elapse between each arrival. The FAA is designed to disperse the battalion while at the same time allowing the battalion to observe all of the avenues of the high-speed approach into the FAA.

(3) Security. Security of the FAA is based on the ability of the battalion to detect threats and react to them by moving the aircraft to another location. Crews will complete a through-flight inspection of their aircraft immediately after the FAA security has been established. Battalion aircraft must be prepared for rapid departure. The priority of tasks for each company is to--

- Establish local security.
- Establish wire communications with the tactical CP.
- Complete through-flights of aircraft.

FM 1-112

- Continue to plan missions.

G-3. EMERGENCY DISPLACEMENTS

a. General. An ATKHB is most vulnerable while occupying assembly areas and FAAs. If an ATKHB comes under an artillery, ground, or air attack while it occupies an assembly area or FAA, it must conduct emergency displacement actions. The two types of plans for emergency displacements are the early warning and the surprise displacement plans. A displacement plan enables the battalion to displace rapidly. It is a part of the security for the assembly area or FAA and must be established before the aircrews arrive. Displacement plans for each company will include the direction and route for leaving an area, the location of HAs, alternate assembly areas, or FAAs and battle positions. Areas to which the ATKHB will displace must be coordinated through the aviation brigade and the ground commander who controls the area.

b. Early Warning. When an enemy attack is imminent, the ATKHC will initiate the battalion displacement plan. On order, aircraft depart the assembly area or FAA using preselected routes and flight modes. Companies maintain platoon or section integrity, occupy their selected HAs and await further instructions from the ATKHB headquarters.

c. Surprise. In the event of a surprise attack, the ATKHC will displace from its position without orders. Aircraft will depart individually and use the preplanned routes to the HAs. The first aircraft to arrive at the HA conducts a reconnaissance and secures the area. Upon arrival at the HA, The ATKHC commander establishes control of the company, transmits a SITREP to the battalion and awaits further instruction. Aircraft systems' alignment and warm-up will be accomplished en route or at the HA.

G-4. FORCE PROTECTION

a. Defense of an assembly area is a difficult task for all aviation units, not just ATKHBs. The personnel austerity of the ATKHB makes this an especially challenging, but not impossible, task. The ATKHB can accomplish the basics of force protection.

(1) All roads that are not absolutely necessary to the operation of the assembly area should be blocked and covered with fire.

(2) The ATKHB requests engineer support to dig fighting positions and block avenues of approach.

(3) The ATKHB makes maximum use of booby-trap and command-detonated munitions.

(4) High speed avenues of approach should be blocked and covered by the fire of the ATKHB's organic crew served weapons.

(5) The ATKHB establishes a QRF and begins rehearsals as soon as possible.

(6) The ATKHB rehearses emergency displacement to each company position both day and night to react to a threat.

b. Considerations. A strong, responsive QRF can make up for limitations of the large area needed by an aviation unit as well as the lack of soldiers available to defend it. Observation posts and fighting positions should use night vision devices. All aviation units have night vision devices that can be used during the hours of darkness for perimeter defense. Each company commander will be made responsible for a sector of the perimeter. Insure that they know what they are responsible for and that the units are tied in with the units on the left and right. The perimeter should be patrolled several times each day and night.

APPENDIX H

DEEP OPERATIONS BY KIOWA WARRIOR ATTACK HELICOPTER BATTALIONS

H-1. PURPOSE

The purpose of this appendix is to provide a discussion of some of the capabilities and limitations of the OH-58D KW ATKHB with respect to deep operations.

H-2. BACKGROUND

a. The question of whether or not KW ATKHB conduct deep operations is answered after proper consideration of METT-T.

b. FM 101-5-1 (final draft dated 15 July 1995) defines deep operations as, "Those operations directed against enemy forces and functions which are not in contact at the forward line of troops (FLOT), line of departure (LD), or friendly perimeter and are between the FLOT/perimeter and the forward boundary of the unit conducting the operation. These operations employ long range fires, air and ground maneuver, and C2W to defeat the enemy by denying him freedom of action and disrupting his preparation for battle, his support structure, and/or disrupting/destroying the coherence and tempo of his operations."

H-3. PURPOSE OF DEEP OPERATIONS

The purpose of deep operations is to support the commander's overall scheme of maneuver by--

a. Influencing the conditions under which current/future close operations are occurring/will occur by delaying, disrupting, or destroying enemy forces, facilities, or other high pay-off targets.

b. Shaping the battlefield for future operations such as creating opportunities for offensive exploitation or to seize the initiative.

c. Targeting the enemy's freedom of action, coherence, and tempo of operations.

H-4. METT-T

Deep attacks to destroy armored and other forces are feasible missions for KW ATKHBs given the circumstances of the mission. The following discussion of METT-T provides useful information to KW ATKHB mission planners that should aid their selection of realistic targets.

a. Mission. The circumstances where a light division commander would need to conduct deep operations against enemy forces as stated in the above definition is very probable. What the commander must consider, however, is the desired effect that he wishes to impart on the enemy and the KW ATKHB's combat power.

b. Enemy. Consideration of the enemy unit's size, strength, location, disposition, activity, equipment, and probable COA is made by planners within the decide, detect, deliver, and assess process. Planners must consider the following factors when targeting:

(1) Potential. Enemy force's/unit's current or future contribution to the close battle (Division: next 12 to 24 hours, Corps: next 24 to 48 hours).

(2) Criticality. Attacking this force/unit will impede the enemy's ability to concentrate forces, control operations, or support his operations at critical times.

(3) Size and success criteria. As you will see after reading the troops discussion below, a feasible destroy mission for a KW ATKHB is an armored battalion. If the mission is to attrit, delay, or disrupt, a larger force could be the target.

c. Terrain. Planners must consider the enemy force's/unit's present or future location and timing in that location in order to determine its vulnerability to attack helicopters during targeting.

Note: The conditions that maximize effectiveness and minimize risk for deep operations are terrain that supports engagements from stand-off ranges and darkness.

d. Troops. Unlike Appendix A, which discusses a single KW's capabilities and limitations, this section will discuss collective capabilities and limitations of KW units.

(1) Firepower. Figure H-1 depicts the TOE authorized quantities of weapons systems components for KW ATKHBs.

| <u>LIN</u> | <u>NOUN</u> | <u>QTY/Co</u> | <u>QTY/Bn</u> | <u>No. of Rnds</u> |
|------------|---|---------------|---------------|--------------------|
| L44830 | Launcher, guided missile aircraft (Hellfire) | 8 | 24 | 48 |
| L45199 | Launcher, rocket aircraft 2.75-inch 7-tube M260 | 8 | 24 | 168 |
| L67246 | Launcher, guided missile aircraft XM292 (ATAS) | 4 | 12 | 48 |
| Z40354 | Machine gun caliber .50: XM296 | 6 | 18 | 9,000 |

Note: Given that the KW has two weapons mounting points, the number of rounds indicated above are battalion maximums for that particular weapon system. While each battalion has 78 weapons system components only 48 mounting points are available.

Figure H-1. Authorized weapons system components

As you can see, a "heavy missile" (two launchers/aircraft) configuration for all 24 aircraft is not possible. As a result, the greatest number of Hellfire missiles that a KW ATKHB can bring at one time to the battle is **48** as compared to an Apache battalion's **384** (aircraft availability not considered). A TOE change to increase the number of Hellfire launchers from 24 to 48 has been requested by some KW units. If approved, this would permit the KW Attack Battalion to increase the number of missiles available for an attack, but self-protection, as discussed below, must not be overlooked by planners.

(2) **Self-protection.** KW aircrews use their 2.75-inch rockets or caliber .50 machine gun to engage close in targets and unexpected contacts for self-protection of themselves or their wingman. The crew of a "heavy missile" KW relies upon its wingman solely for this critical support. As a result, a "mix" of rockets and caliber .50 should always be used by KW ATKHB when conducting deep operations where such instances of close in enemy targets and unexpected contacts are likely.

(3) **Survivability.** Figure H-2 compares and contrasts survivability aspects between the AH-64 Apache and KW.

(4) **SEAD.** KW ATKHB are organic to light divisions which possess 105 millimeters towed howitzers as their primary delivery system of interdicting fires for lethal SEAD. Deep attacks beyond the supporting range of these weapon systems require direct supporting fires from outside the division (such as Corps) if lethal SEAD is necessary to minimize risks to aircrews en route and in objective area.

| <u>Factor</u> | <u>KW to Apache</u> |
|----------------------------------|--|
| Aircraft Survivability Equipment | Less robust package |
| Signature (radar, IR, visual) | Smaller (most mounted sight great advantage) |
| Systems | Fewer redundant |
| Speed | Slower |
| Ballistic Protection | Less for aircraft systems and crew |

Figure H-2. Survivability: KW to Apache

e. **Time.** The only difference between KW and Apache ATKHB in this respect is time available to execute the deep operation. Unlike the Apache, the KW can not "hang" an external fuel tank to extend its mission duration--time on station or combat radius for the attack. As stated in Appendix A, the planning airspeed for a KW is 100 knots, which yields a combat radius of approximately 120 kilometers with approximately 20 minutes station time on a full tank of fuel.

H-5. COMBINED KW AND APACHE DEEP OPERATIONS

A technique of task organizing KWs and Apaches for a deep operation provides commanders with an extremely flexible, robust, and comprehensive attack package. KWs are well suited for target acquisition, designation, security, and final engagement/BDA augmenting the Apache's destruction capability in the engagement area significantly.

APPENDIX I

THEATER MISSILE DEFENSE--SEARCH AND ATTACK

I-1. PURPOSE

FM 1-111 describes the two methods in which Army Aviation assets attack TMD targets as a deliberate attack on a precise location and a more probable Search and Attack in a specified area. The purpose of this appendix is to provide specific TTP for TMD search and attack missions. Lessons learned from and TTP used during Roving Sands '95--an advanced warfighting experiment where an AH-64A ATKHB executed live TMD attack operations missions, were used as a basis for discussion of this *emerging doctrine*.

I-2. TMD OPERATIONS

TMD is inherently a joint mission. It is composed of four operational elements: passive defense, active defense, attack operations, and C⁴I. TMD operations are characterized by centralized planning at EAC level by the TAADE and at Corps level by the DOCC, and decentralized execution by joint, maneuver, and FS units. A wide variety of national and theater assets are employed to detect and service TMD targets. For more information on TMD refer to FMs 100-12 and 90-36.

I-3. TMD ATTACK OPERATIONS

TMD attack operations are both preemptive and reactive. Detection and destruction of TBMs prior to launch is the preferred method of attack. However, although they are not impossible to locate prior to launch, TBMs are extremely difficult to detect until after they have compromised their location with their missile launch signature.

I-4. THREAT TTP

An enemy that possesses and employs TBMs will most likely move his TELs between hide, load, and launch sites. He will use a "shoot and scoot" method of employment because the probability of detection of his TELs increases greatly after a TBM launch. Depending upon the system, an average TBM crew can egress a firing location in 1.5 to 10 minutes and can travel at speeds up to 70 kph depending upon the availability of roads and road conditions. Specific, classified threat information can be found in Defense Intelligence Agency publications DST-1040S-559-91, June 1991 and DST-1040S-529-91, September 1991.

I-5. TCT

Based upon the above threat TTP, the essence of TMD is TCT where an attack system decision process is used at EAC/Corps level based upon the launch sight, detection sensor

FM 1-112

accuracy, time to deliver ordnance, and available delivery systems at the time of the detection. Under certain circumstances, attack helicopters are the weapon of choice for TMD attack operations.

I-6. SEARCH AND ATTACK TTP

A search and attack mission is a variation of the movement to contact. For attack helicopters, it is planned, prepared for, and executed in a similar manner to a movement to contact.

movement to contact-- "A form of the offense designed to develop the situation and to establish or regain contact." **FM 101-5-1** (draft dated 31 July 1996)

search and attack-- "To find and destroy enemy forces or to collect information." **FM 100-40** (initial draft dated 15 March 1996)

The objective of a search and attack mission is to locate and destroy specified enemy targets within a certain area.

a. Planning. The speed with which attack helicopter units can execute given missions is not to be confused with the amount of time that it takes them to plan and prepare for missions. Attack helicopter units are extremely capable, as discussed in Chapter 1, but require the same amount of planning and preparation time as ground forces. Therefore, commanders must ensure that sufficient time is allocated to planning and preparing for all missions, especially a high risk mission to search for and attack TBMs behind enemy lines.

Note: There are currently two methods for employing attack helicopters in TMD attack operations. They are as a dedicated force for TMD (unit's sole mission is TMD attack), and as a result of a divert from other ongoing missions (such as deep attack or raid). Commanders must ensure that the attack helicopter unit has sufficiently planned and prepared for both of these methods. **In the instance of a divert, an essential requirement is a B/P or O/O mission statement that will result in critical planning and preparation by the attack helicopter unit.**

Figure I-1 is a list of critical planning considerations for TMD search and attack missions with references to the element that completes this planning.

| | |
|---------------------------------|--|
| -Control Measures--TMD Template | Attack Battalion |
| -NAI | TAADE/DOCC selected and observed |
| -Routes and SEAD Packages | TAADE/DOCC developed and coordinated |
| -C ³ I | TAADE/DOCC coordinated attack battalion executed |

Figure I-1. Critical planning considerations

(1) **Control measures--TMD template.** Whether attack helicopters are employed for TMD as a dedicated force or diverted from other operations, minimizing the time from TBM detection to friendly engagement is critical to mission success. A technique that the ATKHB experienced great success with during Roving Sands '95 was the use of a TMD Template. Figure I-2 depicts their TMD template and Figure I-3 depicts an example use of a TMD Template. A TMD template is placed upon a map on the coordinates of the TBM launch site. It depicts various search areas for selection based upon the en route time of the attack aircraft to the launch site, TLE, timeliness of TMD launch detection, and predicted TEL egress speeds. It provides standard graphic control measures--boundaries, phase lines, LD, and LOA, for the attack helicopter teams/companies executing the search and attack mission. Commanders should make and use several templates by varying the size of the search areas based upon terrain dependent TEL egress speeds. Commanders orient the template after considering the friendly and enemy situations in the area, ingress and egress routes, and SEAD packages. Commanders should also adjust the template, if necessary, to better fit the terrain in the search area by shifting the entire template or slightly modifying some of the standard boundaries/phase lines. They must be cognizant, however, to not modify too much of the template as they will lose the ability to quickly convey standard mission graphics.

(2) **NAI.** Planners should consider launch location trends and their IPB to designate NAIs for TMD attack operations. As is the case with all NAIs, they must then develop a R&S plan to observe each NAI to detect the TBM or TEL.

(3) **Routes and SEAD packages.** To minimize detection to engagement times, planners should develop routes and SEAD packages to support each TMD NAI. These preplanned routes and SEAD packages can be executed in total or fragmented based upon the target location and position of aircraft at the time of the execution order.

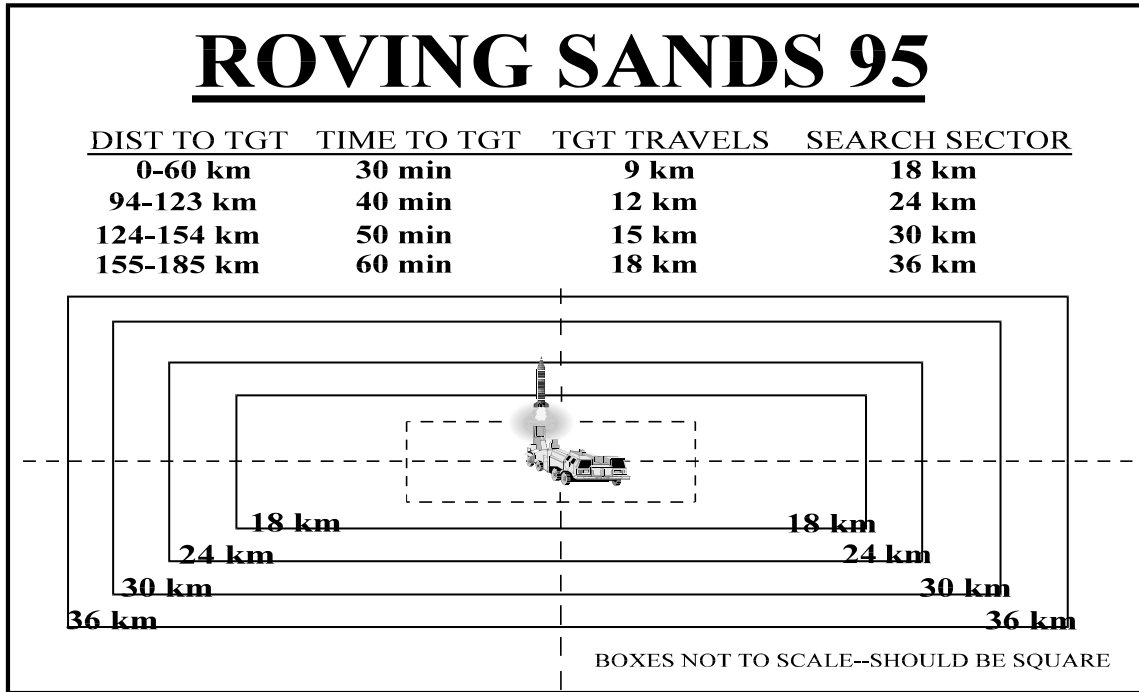

Figure I-2. Example TMD template

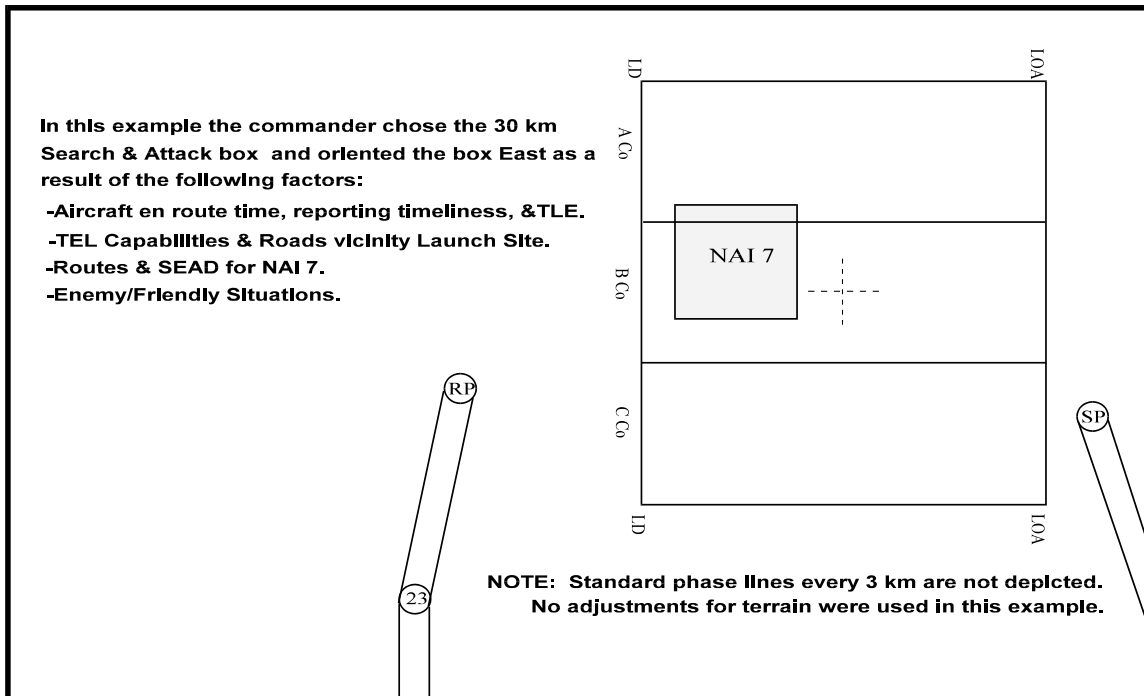

Figure I-3. Example use of TMD template

(4) **C³I**. C³I for TMD attack operations poses some significant challenges. Commanders must develop means to communicate mission specifics, their intent, enemy and friendly SITREPS, and any required changes to subordinates quickly to facilitate a rapid response to TBM targets by their forces. Additionally, FS communications methods and coordination methods must not be overlooked. Over-the-horizon communications or extended range communications techniques must be employed to enable the passing of critical information to attack mission executors. Techniques used during Roving Sands '95 are depicted in Figure I-4. The divert mission presents the most significant communications challenge because of its inherent uncertainty and distance between planners and executors..

| Roving Sands '95 C ³ I | |
|-----------------------------------|-------------------------------------|
| Cdr | AH-64A |
| XO | Airborne Command and Control Center |
| S-3 | Airborne TAC (UH-60) with SATCOM |
| A/S-3 | Airborne Warning and Control System |

Figure I-4. Techniques used during Roving Sands '95

b. Preparation--Training and SOPs. Training and SOPs are the facilitators of rapid response by attack units to TBM threats. Unlike an O/O deep attack mission at a specified location, a TMD search and attack mission's location is unknown until the time of execution. A comprehensive, understood, and thoroughly rehearsed SOP is necessary to minimize risk and increase the probability of mission accomplishment.

c. Execution. As stated above, a search and attack mission for attack helicopters is executed in the same manner as a movement to contact. Depending upon the search area, the battalion commander may decide to use one, two, or all of his companies. Commanders must consider the factors of METT-T to choose the appropriate force to execute TMD search and attack missions.

"Key considerations in any movement to contact include focusing all efforts on finding the enemy and initiating contact with the

smallest element possible." FM 100-40 (initial draft dated 15 March 1996)

(1) **Company level.** With regard to the above discussion and because speed, security, and detailed reconnaissance are essential, the best way for a company to execute this mission is with three two ship scout-attack teams abreast in the company sector. This method balances the principles of economy of force and orienting on the reconnaissance objective. If the remaining company aircraft are available, they can be incorporated into a fourth sector or used as a trailing reaction or C² element.

(2) **Mission briefing.** Conveying mission specific control measures in as rapid a manner as possible is essential to facilitate successful TCT. A standard mission briefing enables the battalion commander to effectively and rapidly communicate essential mission information to executing aircrews. Figure I-5 depicts a sample TBM mission briefing. A mission briefing format similar to this was used during Roving Sands '95 with great success.

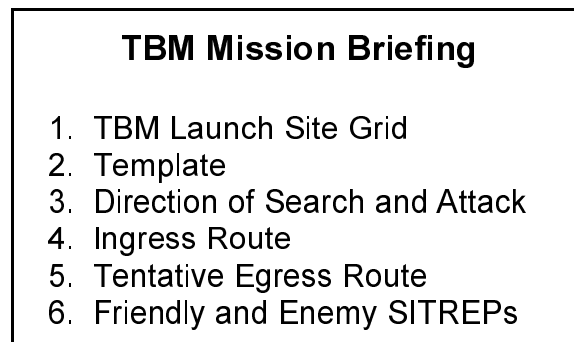

Figure I-5. Sample TBM mission briefing

I-7. HIGH PAY-OFF TARGETS

While the destruction of TELs will degrade the enemy's ability to shoot TBMs, a target with a higher pay-off is a TBM reload site. A technique for finding these sites is one of tracking the TEL from its launch site to its hide site and further tracking to a reload site. TMD attacks on these sites have the possibility of destroying the original TEL, other TELs, TBMs, and TBM personnel. This surveillance could take considerable time and is most likely a SOF or UAV surveillance mission. In this manner, attack assets can use reactive measures to conduct preemptive strikes.

REFERENCES

SOURCES USED

These are the sources quoted or paraphrased in this publication.

Army Regulations

- AR 55-29. Military Convoy Operations in CONUS. 3 September 1971.
- AR 55-113. Movement of Units Within Continental United States. 19 July 1973.
- AR 55-162. Permits for Oversize, Overweight, or Other Special Military Movements on Public Highways in the United States. 1 January 1979.
- AR 95-1. Army Aviation: Flight Regulations. 30 May 1990.
- AR 351-1. Individual Military Education and Training. 15 October 1987
- AR 600-20. Army Command Policy. 30 March 1988.

Field Manuals

- FM 1-100. Doctrinal Principles for Army Aviation in Combat Operations. 28 February 1989.
- FM 1-109. Aviation Self-Deployment Planning. 29 May 1987.
- FM 1-111. Aviation Brigades. 27 August 1990.
- FM 1-114. Tactics, Techniques, and Procedures for the Regimental Aviation Squadron. 20 February 1991.
- FM 1-140. Helicopter Gunnery. 29 March 1996.
- FM 3-3. Chemical and Biological Contamination Avoidance. 16 November 1992.
- FM 3-5. NBC Decontamination. 17 November 1993.
- FM 3-50. Smoke Operations. 4 December 1990.
- FM 14-7. Finance Operations. 17 August 1994.
- FM 16-1. Religious Support. 26 May 1995.
- FM 17-95. Cavalry Operations. 19 September 1991.
- FM 17-98. Scout Platoon. 9 September 1994.
- FM 34-1. Intelligence and Electronic Warfare Operations. 27 September 1994.
- FM 34-7. Intelligence and Electronic Warfare Support to Low-intensity Conflict Operations. 18 May 1993.
- FM 34-10. Division Intelligence and Electronics Warfare Operations. 25 November 1986.
- FM 34-80. Brigade and Battalion Intelligence and Electronic Warfare Operations. 15 April 1986.
- FM 34-130. Intelligence Preparation of the Battlefield. 8 July 1994.
- FM 55-9. Unit Air Movement Planning. 5 April 1993.
- FM 55-12. Movement of Units in Air Force Aircraft. 10 November 1989.
- FM 55-15. Transportation Reference Data. 9 June 1986.

FM 1-112

FM 55-30. Army Motor Transport Units and Operations. 14 March 1980.
FM 55-65. Strategic Deployment. 3 October 1995.
FM 55-312. Military Convoy Operations in the Continental United States. 3 April 1991.
FM 63-2. Division Support Command, Armored, Infantry, and Mechanized Infantry Divisions. 20 May 1991.
FM 63-3. Corps Support Command. 30 September 1993.
FM 63-23. Aviation Support Battalion. 6 June 1996.
FM 71-100. Division Operations. 28 August 1996.
FM 100-5. Operations. 14 June 1993.
FM 100-10. Combat Service Support. 3 October 1995.
FM 101-5. Staff Organization and Operations. 25 May 1984.
FM 101-5-1. Operational Terms and Symbols. 21 October 1985.

Department of the Army Forms

DA Form 2028. Recommended Changes to Publications and Blank Forms. 1 February 1974.
DA Form 2627. Record of Proceedings Under Article 15, UCMJ. August 1984.

Department of Defense Forms

DD Form 458. Charge Sheet. August 1984.

Soldier Training Publication

STP 21-1-SMCT. Soldiers Manual of Common Tasks Skill Level 1. 1 October 1994.

Technical Manuals

TM 38-250. Preparing Hazardous Materials for Military Air Shipments. 25 November 1994.
TM 55-208. Railway Equipment Characteristics and Data. 5 October 1976.
TM 55-625. Transportability Criteria and Guidance for Loading and Unloading Multilevel Railcars at Military Installations in the United States. 15 August 1970.
TM 55-2200-001-12. Transportability Guidance for Application of Blocking, Bracing, and Tiedown Materials for Rail Transport. 31 May 1978.

Training Circular

TC 1-210. Aircrew Training Program Commander's Guide to Individual and Crew Standardization. 3 October 1995.
TC 1-201. Tactical Flight Procedures. 20 January 1984.

DOCUMENTS NEEDED

These document must be available to the intended user of this publication.

Army Regulations

- AR 5-9. Intraservice Support Installation Area Coordination. 1 March 1984.
- AR 25-400-2. The Modern Army Recordkeeping System (MARKS). 26 February 1993.
- AR 55-4. CONUS Military Installation Materiel Outloading and Receiving Capability Report. 15 December 1984.
- AR 55-9. Overseas Ocean Terminal Handling and Inland Line-Haul Cargo Cost Report. 28 November 1975.
- AR 55-23. Submission of Dry Cargo Requirements and the Assignment and Allocation of Sea Transportation Space. 27 March 1978.
- AR 55-36. DOD Use of Domestic Civil Transportation Under Emergency Conditions. 1 April 1980.
- AR 55-60. Official Table of Distances (Continental United States, Alaska, Hawaii, Canada, Canal Zone, Central America, Mexico, and Puerto Rico). 1 December 1981.
- AR 55-71. Transportation of Personal Property and Related Services. 1 June 1983.
- AR 55-355. Defense Traffic Management Regulation. 31 July 1986.
- AR 59-18. Management of System 463L Pallets, Nets, and Tie-Down Equipment. 25 March 1988.
- AR 70-47. Engineering for Transportability. 19 August 1985.
- AR 71-31. Management System for Tables of Organization and Equipment. 20 July 1989.
- AR 190-11. Physical Security of Arms, Ammunition, and Explosives. 30 September 1993.
- AR 220-10. Preparation for Oversea Movement of Units (POM). 15 June 1973.
- AR 220-15. Journals and Journal Files. 1 December 1983
- AR 310-25. Dictionary of United States Army Terms. 15 October 1983.
- AR 310-49. The Army Authorization Documents System (TAADS). 15 December 1980.
- AR 380-5. Department of the Army Information Security Program. 25 February 1988.
- AR 385-10. Army Safety Program. 23 May 1988
- AR 700-15. Packaging of Materiel. 25 October 1990.
- AR 740-32. Responsibilities for Technical Escort of Dangerous Materials. 5 June 1975.
- AR 746-1. Packaging of Army Materiel for Shipment and Storage. 8 October 1985.

Department of the Army Forms

- DA Form 581. Request for Issue and Turn-In of Ammunition. August 1989.
- DA Form 1594. Daily Staff Journal or Duty Officer's Log. 1 November 1962.
- DA Form 2404. Equipment Inspection and Maintenance Worksheet. 1 April 1979.
- DA Form 4004. Message Book M-210-B. 1 February 1977.

FM 1-112

DA Pamphlets

- DA PAM 25-30. Consolidated Index of Army Publications and Blank Forms. 1 October 1996.
DA PAM 746-1. Pallets and Storage Aids for Army Use. 28 October 1988.

Field Manuals

- FM 1-102. Army Aviation in an NBC Environment. 30 September 1985.
FM 1-104. Tactics, Techniques, and Procedures for Forward Arming and Refueling Points. 12 September 1994.
FM 1-116. Tactics, Techniques, and Procedures for the Air Cavalry/Reconnaissance Troop. 20 February 1991.
FM 1-117. Air Reconnaissance Squadron. 30 May 1989.
FM 1-202. Environmental Flight. 23 February 1983.
FM 1-301. Aeromedical Training for Flight Personnel. 29 May 1987.
FM 3-4. NBC Protection. 29 May 1992.
FM 3-6. Field Behavior of NBC Agents (Including Smoke and Incendiaries). 3 November 1986.
FM 3-7. NBC Field Handbook. 29 September 1994.
FM 3-100. Chemical Operations Principles and Fundamentals. 8 May 1996.
FM 5-33. Terrain Analysis. 11 July 1990.
FM 5-36. Route Reconnaissance and Classification. 10 May 1985.
FM 6-20. Fire Support in the AirLand Battle. 17 May 1988.
FM 8-9. NATO Handbook on the Medical Aspects of NBC Defensive Operations. 1 February 1996..
FM 8-285. Treatment of Chemical Agent Casualties and Conventional Military Chemical Injuries. 22 December 1995.
FM 10-27. General Supply in Theaters of Operations. 20 April 1993.
FM 12-6. Personnel Doctrine. 9 September 1994.
FM 21-11. First Aid for Soldiers. 27 October 1988.
FM 34-1. Intelligence and Electronic Warfare Operations. 27 September 1994.
FM 34-3. Intelligence Analysis. 15 March 1990.
FM 34-40. (S)Electronic Warfare Operations(U). 9 October 1987.
FM 34-81. Weather Support for Army Tactical Operations. 31 August 1989.
FM 44-8. Small Unit Self-Defense Against Air Attack. 30 December 1981.
FM 55-10. Movement Control in a Theater of Operations. 8 December 1992.
FM 55-20. Army Rail Transport Units and Operations. 31 October 1986.
FM 71-3. The Armored and Mechanized Infantry Brigade. 8 January 1996.
FM 90-21. JAAT Multi-service Procedures for Joint Air Attack Team Operations. 16 October 1991.
FM 100-15. Corps Operations. 13 September 1989.
FM 100-103. Army Airspace Command and Control in a Combat Zone. 7 October 1987.

Technical Bulletins

- TB 55-45. Certification of Military Equipment for Transport in MCA/CRAF Aircraft. 15 January 1995.
- TB 55-46-1. Standard Characteristics (Dimensions, Weight, and Cube) for Transportability of Military Vehicles and Other Outsize/Overweight Equipment. 1 January 1996.
- TB 55-46-2. Standard Transportability Characteristics (Dimensions, Weight, and Cube) for Military Vehicles and Equipment. 15 January 1996.

Technical Manuals

- TM 3-4240-280-10. Operations Manual for Mask, Chemical-Biological: Aircraft, ABC-M24 and Accessories and Mask, Chemical-Biological, Tank, M25A1 and Accessories. 15 March 1988.
- TM 38-230-1. Packaging of Materiel: Preservation (Vol I). 1 August 1982.
- TM 38-230-2. Packaging of Materiel: Preservation (Vol II). 15 June 1977.
- TM 55-603. Movement of Military Impediments by Commercial Carriers. 28 October 1977.

READINGS RECOMMENDED

These readings contain relevant supplemental information.

Command publications cannot be obtained through Armywide resupply channels. Availability may be determined by contacting the address shown.

TRADOC Training Texts

- TRADOC Training Text 34-3. Joint Laser Designator Procedures, December 1985
- TRADOC Training Text 100-44-1. Joint Suppression of Enemy Air Defense (J-SEAD), June 1982
- TRADOC Training Text 525-45. General Operating Procedures for Joint Attack of the Second Echelon (J-SAK), December 1984

Commander
US Army Training and Doctrine Command
ATTN: ATCD-ALFA
Langley AFB, VA 23665

FM 1-112

PROJECTED PUBLICATIONS

Projected publications are sources of information that are scheduled for printing but are not yet available. Upon print, they will be distributed automatically via pinpoint distribution. They may not be obtained from the US Army Publications Distribution Center, 2800 Eastern Boulevard, Baltimore, Maryland 21220-2896, until indexed in DA Pamphlet 25-30.

Field Manuals

FM 1-546. Shipboard Operations. Projected Publication Date: June 1997.

FM 1-140-1. Master Gunner Handbook. Projected Publication Date: June 1997.

FM 90-36. Targeting. (Final Signature Draft dated May 1996) Project Publication Date: June 1977

FM 100-20. Stability and Support Operations. (Final draft dated April 1996) Projected Publication Date: June 1997.

FM 100-40. Tactics. (Initial draft dated 15 March 1996) Projected Publication Date: June 1997.

FM 101-5-1. Operational Terms and Symbols. (Drag edition dated 31 July 1996) Projected Publication Date: July 1997.

GLOSSARY

ACRONYMS AND ABBREVIATIONS

| | |
|-------------------------------|---|
| A ² C ² | Army airspace command and control |
| AA | avenue of approach |
| AADC | area air defense commander |
| AAR | aircraft accident report/after-action report |
| AARS | Advanced airborne radius system |
| AAST | Army aerial scout test |
| AATF | assault aircraft task force |
| AATFC | assault aircraft task force commander |
| ABCCC | airborne command and control center |
| ABF | attack by fire |
| ABMOC | air battle management operations center |
| ABN | air battle net |
| ACA | airspace coordination area |
| acft | aircraft |
| ACP | air control point |
| ACR | armored cavalry regiment |
| ACUS | area common user system |
| AD | air defense |
| ADA | air defense artillery |
| ADSS | ANVIS display symbology system |
| AFATDS | advanced field artillery tactical data system |
| AFSO | Aviation fire support officer |
| AH | attack helicopter |
| AHB | assault helicopter battalion |
| AHRS | attitude and heading reference system |
| AHT | assault helicopter troop |
| AI | air interdiction |
| A&L | administrative and logistics |
| AL | Alabama |
| ALB-F | AirLand battle-future |
| ALFGL* | automatic low frequency gain limiting |
| ALO | air liaison officer |
| ALSE | aviation life support equipment |
| alt | altitude |
| ALT | airborne laser tracker |
| AO | area of operation |
| AM | amplitude modulated |

*Control display subsystem nomenclature.

FM 1-112

| | |
|---------|--|
| AMB | air mission brief |
| AMC | air mission commander |
| ammo | ammunition |
| AMO | aviation maintenance officer |
| AMPS | aviation mission planning system |
| ANGLICO | air and naval gunfire liaison company |
| ANVIS | aviator's night vision imaging system |
| AP | ammunition point |
| APC | armored personnel carrier |
| APU | auxiliary power unit |
| AR | Army regulation |
| ARI | Aviation Research Initiative |
| ARFOR | Army forces |
| ART | air reconnaissance troop |
| ARTEP | Army training and evaluation program |
| arty | artillery |
| ARTY* | artillery |
| ASARS | advanced synthetic aperture radar system |
| ASAS | all source analysis system |
| ASB | aviation support battalion |
| ASE | aircraft survivability equipment |
| ASO | aviation safety officer |
| ASOC | air support operations center |
| ASP | aerial supply point |
| ASPS | all-source production section |
| asst | assistant |
| ATA | air-to-air |
| ATACMS | Army tactical missile system |
| ATAS | air-to-air Stinger |
| ATGM | antitank guided missile |
| ATHS | airborne target handover system |
| atk | attack |
| ATKHB | attack helicopter battalion |
| ATKHC | attack helicopter company |
| ATKHR | attack helicopter regiment |
| ATO | air-tasking order |
| ATP | Allied Tactical Publication or ammunition transfer point |
| ATS | air traffic services |
| attn | attention |
| AVGAS | aviation gasoline |
| AVIM | aviation intermediate maintenance avn aviation |

*Control display subsystem nomenclature.

| | |
|------------------|---|
| AVUM | aviation unit maintenance |
| AWACS | Airborne Warning and Control System |
| BAI | battlefield air interdiction |
| BCE | battlefield coordination element |
| BCS | battery computer system |
| BDA | battle damage assessment |
| bde | brigade |
| BH* | black-hot |
| BHL | battle handover line |
| BMNT | beginning of morning nautical twilight |
| BMO | battalion maintenance officer |
| bn | battalion |
| BOS | battlefield operating systems |
| BP | battle position |
| B/P | be prepared |
| BRASSCRAF | background, range to target, altitude, sun, shadows, cover and concealment, rotor wash, adequate maneuver area, fields of fire BRT*brightness |
| BSA | brigade support area |
| C ² | command and control |
| C ³ | command, control, and communications |
| C ² I | command, control, and intelligence |
| C ³ I | command, control, communications, and intelligence |
| C ⁴ I | command, control, communications, computers, and intelligence |
| CAA | combined arms armies (Soviet) |
| CAB | command aviation battalion |
| cal | caliber |
| CAN | combat aviation net |
| CAS | close air support |
| CB | chemical and biological |
| cdr | commander |
| CE | Corps of Engineers |
| CEOI | Communications-Electronics Operation Instruction |
| CFL | coordinated firing line |
| CFS | close-in fire support |
| cGy | centigray |
| CH* | channel |
| CHEMWARN | chemical strike warning |
| CHS | combat health support |
| CI | combat ineffective |

*Control display subsystem nomenclature.

FM 1-112

| | |
|----------|--|
| CM | centimeter |
| CM&D | collection, management, and dissemination |
| cmd | command |
| CMTC | Combined Maneuver Training Center |
| CNR | combat net radio |
| co | company |
| COA | course of action |
| COMINT | communications intelligence |
| COMJAM | communications jamming |
| COMM* | communications |
| comp | component |
| COMSEC | communications security |
| CONEX | container express |
| CONT* | contrast |
| CONUS | continental United States |
| COSCOM | corps support command |
| CP | command post |
| CPG | copilot-gunner |
| CPO | copilot-observer |
| CPX | command post exercise |
| CS | combat support |
| CSA | corps storage area |
| CSAR | combat search and rescue |
| CSM | command sergeant major |
| CSS | combat service support |
| CSSCS | combat service support control system |
| CTOC | corps tactical operations center |
| CTT | commander's tactical terminal |
| CTT-H | commander's tactical terminal-Hybrid |
| CUCV | commercial utility cargo vehicle |
| CVMS | combat vehicle marking system |
| DA | Department of the Army or density altitude |
| DAO | division ammunition officer |
| DART | downed aircraft/aircrews recovery team |
| DD | Department of Defense |
| DEA | Drug Enforcement Agency |
| decon | decontamination |
| DEK | data entry keyboard |
| DF | direction finder |
| DIR WPT* | direct way point |
| DISCOM | division support command |

*Control display subsystem nomenclature.

| | |
|-------|---|
| div | division |
| DLQ | deck landing qualification |
| DMMC | division materiel management center |
| DOCC | deep operations coordination cell |
| DOD | Department of Defense |
| DP | delivery point |
| DPICM | dual-purpose improved conventional munition |
| DS | direct support |
| DSA | division support area |
| DT | demanding task |
| DTG | date-time group |
| DTS | data transfer system |
| DVO | direct view optics |
| | |
| E | east |
| EA | engagement area/electronic attack |
| EAC | echelons above corp |
| ECCM | electronic counter-countermeasures |
| ECM | electronic countermeasures |
| EEFI | essential elements of friendly information |
| E EI | essential elements of information |
| EENT | end of evening nautical twilight |
| EER | enlisted evaluation report |
| EFLT | enemy front line trace |
| ELINT | electronic intelligence |
| EMP | electromagnetic pulse |
| EP | electronic protection |
| EPLRS | enhanced position location reporting system |
| EPW | enemy prisoner of war |
| ERFS | extended range fuel system |
| ES | electronic support |
| ESM | electronic warfare support measures |
| ESSS | external stores support system |
| ETE | estimated time en route |
| EXTAL | extra time allowance |
| ETL | effective translational lift |
| EW | electronic warfare |
| | |
| F | Fahrenheit |
| FA | field artillery |
| FAA | forward assembly area |
| FAAD | forward area air defense |
| FAAO | field artillery air observer |

*Control display subsystem nomenclature.

FM 1-112

| | |
|---------|---|
| FAC | forward air controller |
| FAIO | field artillery intelligence officer |
| FARE | forward area refueling equipment |
| FARM | fuel, ammunition (cannon), rockets, missiles |
| FARP | forward arming and refueling point |
| FASCAM | family of scatterable mines |
| FDC | fire direction center |
| FEBA | forward edge of battle area |
| FFA | free-fire area |
| FFAR | folding fin aerial rocket |
| FIST | fire support team |
| FLIR | forward-looking infrared |
| FLOT | forward line of own troops |
| FM | field manual or frequency modulated |
| FMC | fully mission capable |
| FMCP | fuel management control panel |
| FO | forward observer |
| FOD | foreign object damage |
| FOV | field of view |
| FPLN* | flight plan |
| FRAGO | fragmentary order |
| FR FRZ* | frame freeze |
| FS | fire support |
| FSB | forward support battalion |
| FSCoord | fire support coordinator |
| FSE | fire support element |
| FSCL | fire support coordination line |
| FSO | fire support officer |
| FSS | fast sealift ships |
| FSU | field storage unit |
| Ft | Fort |
| | |
| G1 | Assistant Chief of Staff, G1 (Personnel) |
| G2 | Assistant Chief of Staff, G2 (Intelligence) |
| G3 | Assistant Chief of Staff, G3 (Operations and Plans) |
| GBAB | general support aviation battalion |
| GCU | gas charging unit |
| GLLD | ground laser locator designator |
| gph | gallons per hour |
| GPM | gallons per minute |
| GPS | global positioning system |
| GRM | graduated response matrix |
| GRREG | graves registration |

*Control display subsystem nomenclature.

| | |
|------------|--|
| GS | general support |
| GSAB | general support aviation battalion |
| GSE | ground support equipment |
| GSM | ground station module |
| GTD | guard tank division (Soviet) |
| GTL | gun-target line |
| G/VLLD | ground/vehicle laser locator designator |
| HA | holding area |
| HAC | helicopter aircraft commander |
| HARS | heading attitude reference system |
| HC | hexachloroethane (smoke) |
| HDU | helmet display unit |
| HE | high explosive |
| HEEDS | helicopter emergency egress device system |
| HEMAT | heavy expanded mobility ammunition tractor |
| HEMTT | heavy expanded mobility tactical truck |
| HF | high frequency |
| H-FAC | heliborne forward air controller |
| HFM | Hellfire missile |
| HF NOE COM | high frequency nap-of-the-earth communications |
| HHC | headquarters and headquarters company |
| HI* | high |
| HIND | Soviet helicopter |
| HIT | health indicator test |
| HPT | high-payoff target |
| HQ | headquarters |
| hr | hour |
| HS | highly sensitive |
| HSC | headquarters and service company |
| HSD | horizontal situation display |
| HSS | health service support HUMINT human intelligence HVT high-value target |
| hvy | heavy |
| ICM | improved conventional munitions |
| ID | identification |
| IEW | intelligence and electronic warfare |
| IFF | identification, friend or foe (radar) |
| IGRV | improved Guardrail V |
| IMC | instrument meteorological conditions |

*Control display subsystem nomenclature.

FM 1-112

| | |
|---------|--|
| IMINT | imagery intelligence |
| inl | initial |
| int | intersection |
| intel | intelligence |
| INTG* | integrate |
| INTSUM | intelligence summary |
| IP | initial point |
| IPB | intelligence preparation of the battlefield |
| IPF | integrated processing facility |
| IR | infrared |
| ISOP | isolation preparation packets |
| ITO | installation transportation office |
| | |
| JAAT | joint air attack team |
| JP | jet petroleum |
| JP4 | jet engine fuel |
| J-SEAD | joint suppression of enemy air defense |
| J-STARS | joint surveillance target acquisition radar system |
| JTF | joint task force |
| | |
| KIAS | knots indicated airspeed |
| km | kilometer |
| KMIH | kilometers traveled in an hour |
| kmph | kilometers per hour |
| kph | kilometers per hour |
| kt | knot |
| KW | Kiowa Warrior |
| KZ | kill zone |
| | |
| LADW | local air defense warning |
| LAMPS | light airborne multipurpose system |
| LAN | local area network |
| LC | line of contact |
| LD | line of departure |
| ldr | leader |
| LGB | laser-guided bomb |
| LIC | low-intensity conflict |
| LNO | liaison officer |
| LO | low* |
| LOA | limit of advance |
| LOAL | lock-on after launch |
| LOBL | lock-on before launch |
| LOC | lines of communication |

*Control display subsystem nomenclature.

| | |
|---------|---|
| LOGPAC | logistics package |
| LOI | letter of instruction |
| LORAN-C | long range navigation-C series |
| LOS | line of sight |
| LPU | limited production--urgent |
| LRF/D | laser range finder/designator |
| LRSU | long-range surveillance unit |
| LRU | line replaceable unit |
| LRSD | long range surveillance detachment |
| LST | laser spot tracker |
| LTL | laser-to-target line |
| L/W | lead/wingman |
| LZ | landing zone |
| | |
| m | meter |
| MAC | Military Airlift Command |
| MACOM | major Army command |
| MAG | military airlift group |
| MARKS | Modern Army Recordkeeping System |
| max | maximum |
| MCOO | modified combined obstacle overlay |
| MCS | maneuver control system |
| MCS-P | maneuver control system PHOENIX |
| mech | mechanized |
| MEDEVAC | medical evacuation METL |
| | mission-essential task list |
| METT-T | mission, enemy, terrain, troops, and time available |
| MFD | multifunction display |
| MG | machine gun |
| MHE | materiels handling equipment |
| MI | military intelligence |
| MICLIC | mine-clearing line charges |
| MIH | miles traveled in an hour |
| min | minute |
| MLRS | multiple launch rocket system |
| mm | millimeter |
| MMC | materiel management center |
| MMS | mast-mounted sight |
| MOPP | mission-oriented protective posture |
| MOS | military occupational skill |
| MOU | memorandum of understanding |
| mph | miles per hour |

*Control display subsystem nomenclature.

FM 1-112

| | |
|--------------|--|
| MPLH | multipurpose light helicopter |
| MPSM | multipurpose submunition |
| MR | moonrise |
| MRE | meal, ready to eat |
| MRR | minimum risk route |
| MS | moonset or military specification |
| MSB | main support battalion |
| MSE | mobile subscriber equipment |
| MSR | main supply route |
| MTO | message to observer |
| MTOE | modification table of organization and equipment |
| MTP | mission training plan |
| | |
| N | north |
| NAAK | nerve agent antidote kit |
| NAI | named areas of interest |
| NATO | North Atlantic Treaty Organization |
| NAV ALN* | navigation alignment |
| NAV ALN VAR* | navigation alignment variation |
| NAVAIDS | navigational aids |
| NAV UPD* | navigation update |
| NBC | nuclear, biological, chemical |
| NBCWRS | NBC warning and reporting system |
| NDB | nondirectional radio beacon |
| NCO | noncommissioned officer |
| NCOIC | noncommissioned officer in charge |
| NCS | net control station |
| NDB | nondirectional radio beacon |
| NEO | noncombat evacuation operation |
| NEXT WPT* | next way point |
| NFA | no-fire area |
| NFOV | narrow field of view |
| NGF | naval gunfire |
| NM | nautical mile |
| no | number |
| NOE | nap-of-the-earth |
| NORMA | nature of the target, obstacle clearance, range to target, multiple firing positions, adequate area for proper dispersion between aircraft |
| NOTAM | notice to airmen |
| NSN | national stock number |
| NTC | National Training Center |

*Control display subsystem nomenclature.

| | |
|-----------------|--|
| NVD | night vision device |
| NVG | night vision goggles |
| OBS | optical boresight system |
| OCOKA | observation and fields of fire, cover and concealment, obstacles and movement, key terrain, avenue of approach |
| ODA | optical display assembly |
| OE ² | ordnance expenditure exercise |
| OER | officer evaluation report |
| OH | observation helicopter |
| O&I | operations and intelligence |
| OIC | officer in charge |
| O/O | on order |
| OOTW | operations other than war |
| OP | observation post |
| OPCON | operational control |
| OPLAN | operation plan |
| opn | operation |
| OPORD | operation order |
| OPSEC | operations security |
| OR | operational readiness |
| OSET* | offset |
| PA | pressure altitude |
| PAC | personnel and administration center |
| PC | pilot in command |
| PD | performance degraded |
| PIR | priority intelligence requirement |
| P _h | probability of hit |
| P _k | probability of kill |
| PL | phase line |
| plt | platoon |
| PMC | partially mission capable |
| PMCS | preventive maintenance checks and services |
| PNVS | pilots night vision system/sensor |
| POC | point of contact |
| POD | point of debarkation |
| POE | port of entry |
| POL | petroleum, oils, and lubricants |
| POM | preparation of oversea movement of units |
| POR | preparation of replacements for overseas movement |
| PP* | present position |

*Control display subsystem nomenclature.

FM 1-112

| | |
|---------|---|
| PPC | performance planning card |
| PPT* | prepoint |
| PRF | pulse-repetition frequency |
| psi | pounds per square inch |
| PSNCO | personnel staff noncommissioned officer |
| PSS | personnel service support |
| PW | prisoner of war |
| PZ | pickup zone |
| PZCO | pickup zone control officer |
| | |
| QRF | quick reaction force |
| QSTAG | Quadripartite Standardization Agreement |
| | |
| RCC | rescue coordination center |
| RDF | rapid deployment force |
| REDCON | readiness condition |
| RETRANS | retransmit |
| RF | radio frequency |
| RFA | restrictive fire area |
| RFL | restrictive fire line |
| rgt | regiment |
| RIF | reconnaissance in force |
| RKTS* | rockets |
| RL | readiness level |
| rng | range |
| ROE | rules of engagement |
| RORO | roll-on, roll-off |
| RP | release point |
| RPM | revolutions per minute |
| R&S | reconnaissance and surveillance |
| RTO | radio telephone operator |
| | |
| S1 | Adjutant (US Army) |
| S2 | Intelligence Officer (US Army) |
| S3 | Operations and Training Officer (US Army) |
| S4 | Supply Officer (US Army) |
| SAAFR | standard-use Army aircraft flight route |
| SALT | supporting arms liaison team |
| SALUTE | size, activity, location, unit, time, and equipment |
| SAM | surface-to-air missile |
| SASO | stability and support operations |
| SATCOM | satellite communications |
| SB | supply bulletin |
| SBF | support by fire |

*Control display subsystem nomenclature.

| | |
|-----------|---|
| SCL SEL* | scale select |
| SEAD | suppression of enemy air defense |
| sec | section |
| SERE | survival, evasion, resistance, and escape |
| sgt | sergeant |
| SIDPERS | Standard Installation/Division Personnel System |
| SIGINT | signal intelligence |
| SIGSEC | signal security |
| SINCGARS | single channel ground and air radio system |
| SITREP | situation report |
| SJA | staff judge advocate |
| SLAR | side-looking airborne radar |
| SMCT | soldiers manual of common tasks |
| SOF | special operations forces |
| SOI | signal operation instructions |
| SOP | standing operating procedure |
| SOR | specific orders and requests |
| SP | start point |
| SPC | specialist |
| SS | sunset |
| SSSC | self-service supply center |
| STANAG | standardization agreement |
| STB | supertropical bleach |
| STRIKWARN | strike warning |
| STX | situational training exercise |
| swbd | switchboard |
| SWT | scout-weapons team |
| TAADE | theater area air defense element |
| TAADS | The Army Authorization Documents System |
| tac | tactical |
| TAC CP | tactical command post |
| TACC | tactical air control center |
| TACAIR | tactical air |
| TACAN | tactical air navigation |
| TACFIRE | tactical fire |
| TACP | tactical air control party |
| TACS | tactical air control system |
| TACSAT | tactical satellite |
| TADS | target acquisition and designation system |
| TAI | total active aircraft inventory |
| TBM | theater ballistic missile |

*Control display subsystem nomenclature.

FM 1-112

| | |
|-----------|--|
| TCAE | technical control and analysis element |
| TCF | tactical combat force |
| TCT | time critical targeting |
| TD | tank division (Soviet) |
| TDIS | time-distance |
| TDY | temporary duty |
| TEL | transporter erector launcher |
| temp | temperature |
| TF | task force |
| tgt | target |
| TGT LOC* | target locate |
| TIS INTG* | thermal imaging sensor integrate |
| TLE | target location error |
| TM | technical manual |
| TMD | theater missile defense |
| TOC | tactical operations center |
| TOD* | Time of Day |
| TOE | table(s) of organization and equipment |
| TOW | Tube-launched, optically tracked, wire-guided |
| TP* | turn point |
| TR | tank regiment |
| TRADOC | (United States Army) Training and Doctrine Command |
| trp | troop |
| TRAP | tactical recovery of aircraft and personnel |
| TRP | target reference point |
| TSU | telescopic sight unit |
| TSA | theater storage area |
| tt | training text |
| TTP | tactics, techniques, and procedures |
| TV | television |
| TVS | television sensor |
| UAV | unmanned aerial vehicle |
| UCMJ | Uniform Code of Military Justice |
| UH | utility helicopter |
| UHF | ultra high frequency |
| UMO | unit maintenance officer |
| UMNCO | unit maintenance noncommissioned officer |
| UMT | unit ministry team |
| US | United States (of America) |
| USA | United States Army |
| USAF | United States Air Force |
| USAAVNC | United States Army Aviation Center |

*Control display subsystem nomenclature.

| | |
|---------|--------------------------------------|
| USN | United States Navy |
| UT | undemanding task/unit trainer |
| UTM | universal transverse mercator |
| VA | Virginia |
| VAR* | variation |
| veh | vehicle |
| VERTREP | vertical replenishment |
| VHF | very high frequency |
| vis | visibility |
| VMF | variable message format |
| vpk | vehicles per kilometer |
| vpm | vehicles per mile |
| VROC | vertical rate of climb |
| VRS | video recording system |
| VSD | vertical situation display |
| VTR | video tape recorder |
| W | west |
| WARNORD | warning order |
| WCS | weapons control status |
| WFOV | wide field of view |
| WH* | white-hot |
| WIA | wounded in action |
| WP | white phosphorous |
| wpn | weapon |
| WPT* | way point |
| WSRO | weapon system replacement operations |
| XO | executive officer |
| XTK* | cross track |
| ZOS | zone of separation |

*Control display subsystem nomenclature.

INDEX

A²C², 4-27,
AAR, 3-67, 3-68
AATF, B-1-B-8, B-10, B-11
AATFC, B-5, B-7
ABF, 3-11, 3-12, 3-41, 3-42
ABN, B-7
ACA, 4-12, 4-13
ACP, 3-30
ACR, 2-7
ACUS, 2-17
AD, 4-14, 4-16, 4-17
ADA, 2-17, 3-23, 3-63, 3-66, B-14, C-23, D-19, E-2, E-4, F-22, F-25
advanced field artillery tactical data system. See AFATDS.
AFATDS, 2-17
after-action report. See AAR.
AHB, 1-10, 1-12, B-1
air and naval gunfire liaison company. See ANGLICO.
air assault
 battle command, B-7
 planning, B-3
 checklist, B-12
 responsibilities, B-5,
 security, B-1, B-8
air battle net. See ABN.
airborne target handover system. See ATHS.
air combat
 armament, F-14
 battle drills, F-27
 employment, F-5
 engagements, F-16
 fundamentals, F-4
 helicopter, F-12
 planning, F-17
 security, F-6
 scope, F-1
 tactical operations, F-21
 terms, F-52
 threat, F-2
air control point. See ACP.
aircraft survivability equipment. See ASE..
air defense. See AD.
air defense artillery. See ADA.

FM 1-112

- airlift, D-4
- air mission brief. See AMB.
- air mission commander. See AMC
- air reconnaissance troop. See ART.
- airspace coordination area. See ACA.
- air-to-air stinger. See ATAS.
- all source analysis system. See ASAS.
- ALSE, 3-27, D-4
- AMB, B-9
- AMC, B-11
- AMPS, 2-11, 2-16, 3-18, 3-62
- ANGLICO, 4-7
- area common user system. See ACUS.
- ARI, 1-15, 3-4
- armored cavalry regiment. See ACR.
- armament systems
 - AH-64, A-3
 - AH-1, A-8
 - OH-58D, A-10
- Army airspace command and control. See A²C².
- ART, A-4
- ASAS, 2-17
- ASB, 5-1, 5-4
- ASE, 3-66, E-7, F-9, F-22
- assembly area, 3-9, 3-67
 - designation, G-1
 - emergency displacements, G-4
 - force protection, G-4
 - occupation, G-1
- assault aircraft task force. See AATF
- assault aircraft task force commander. See AATFC.
- assault helicopter battalion. See AHB.
- ATAS, A-13, F-14, F-22, H-3
- ATKHB
 - air assault, 1-10
 - airborne, 1-10
 - capabilities, 1-15
 - command relationships, 2-7
 - defense, 1-6
 - employment, 3-1
 - missions, 1-12
 - limitations, 1-17
 - offense, 1-3, 1-4
 - operations, 1-16
 - organization, 1-8, 3-1
 - role, 1-1

ATKHC, 3-3, 3-5
 aircrews, 3-8
 employment, 3-3
 leaders, 3-6
 attack
 continuous, 3-14, 3-15
 deliberate, 1-5
 hasty, 1-4
 phased, 3-14, 3-15
 route, 3-10
 attack aircraft
 AH-1, A-1
 AH-64, A-1
 combat operations, 1-3
 OH-58, A-9
 attack by fire. See ABF.ATHS, A-10
 attack helicopter battalion. See ATKHB.
 attack helicopter company. See ATKHC.
 aviation intermediate maintenance. See AVIM.
 aviation life support equipment. See ALSE.
 aviation mission planning system. See AMPS.
 Aviation Research Initiative See ARI.
 aviation support battalion. See ASB.
 aviation unit maintenance. See AVUM.
 AVIM, 5-2, 5-4
 AVUM, 5-2 through 5-5
 axis of advance, 3-29

 battalion maintenance officer. See BMO.
 battle damage assessment. See BDA.
 battle drills, F-27 through F-52
 battle position. See BF.
 battlefield operating systems. See BOS.
 battlefield stress, 3-23
 BDA, 1-17, 3-66, H-4
 BMO, D-17
 BOS, B-1
 BP, 3-11, 3-13, 3-42,

 C²
 duties and responsibilities, 2-1, 2-3
 process, 2-9-2-12
 C³, 3-4, B-3, B-9, F-20, I-5
 C³I, 3-10, G-1, I-3, I-5
 C⁴I, I-1
 CAB, 1-10, 1-12

FM 1-112

CAN, B-8

CAS, 4-7

checks,

 before mission receipt, 3-25

 communications

 crew, 3-26

 final, 3-26

 precombat, 3-25

 run-up, 3-27

 upon mission receipt, 3-25

CHS, 5-5, 5-6

close air support. See CAS.

CNR, 2-16

COA, 2-8 through 2-11, 3-49,

combat aviation net. See CAN.

combat cruise formation, 3-32

combat health support. See CHS.

combat net radio. See CNR.

combat spread formation, 3-33

combat search and rescue. See CSAR.

combat service support. See CSS.

combat service support control system. See CSSCS.

combat support. See CS.

combat trail formation, 3-37

command and control. See C².

command aviation battalion. CAB.

command communications, 2-14, 2-18

 FM net, 2-19

 company nets, 2-19

 battalion wire net, 2-20

command, control, and communications. See C³.

command, control, communications, and intelligence. See C³I.

command, control, communications, computers, and intelligence. C⁴I.

command post. See CP.

communications

 nets, B-7

 radio nets, 2-18

 wire, 2-18

communications security. See COMSEC.

company mission brief, C-21

company mission debrief, C-23

COMSEC, 3-27

CP, 2-12, 2-13

corps support command. See COSCOM.

COSCOM, 5-1, 5-2, 5-4, D-6

course of action. See COA.

- counter drug operations, 6-2
- CS, 6-1, B-12
 - AD, 4-14
 - Engineer support, 4-19
 - fire support, 4-1
 - IEW operations, 4-12
 - NBC support, 4-19
- CSAR, B-5, B-6, B-12, B-14
- CSS, B-12
 - aircraft support, 5-2
 - ammunition, 5-1, 5-2
 - coordination, 5-1
 - FARPs, 5-2
 - field services, 5-7
 - fuel, 5-1, 5-2
 - personnel services, 5-5
 - planning , 5-1
 - transportation requirements, 5-5
 - vehicle and GSE maintenance, 5-2
- CSSCS, 2-17

- decontamination, 4-22 through 4-24
- deep operations coordination cell. See DOCC.
- defense
 - area, 1-6
 - mobile, 1-6
- direct view optics. See DVO.
- DOCC, 3-45, I-1 through I-3
- DVO, A-3

- EA, 3-13, 3-22, 3-44, 3-48, 3-50, 3-63
- effective translational lift. See ETL.
- egress operations, 3-66
- electronic protection. See EP.
- electronic warfare. See EW.
- employment
 - direct fire, 3-35, 3-55, 3-63
 - EA development, 3-48
 - engagement, 3-64
 - environmental considerations, 3-17
 - methods, 3-14
 - objective area, 3-44
 - other operations
 - organization and roles, 3-1
 - movement, 3-24
 - terms and missions, 3-9

FM 1-112

engagement area. See EA.

environmental

 battlefield stress, 3-23

 EW, 3-22

 NBC weapons, 3-21

 smoke and obscurants, 3-22

 special, 3-18

 terrain, 3-17

 weather, 3-17

 visibility, 3-17

EP, 3-22

ETL, 3-21

EW, 3-22

EXTAL, D-9, D-10, D-12

extra time allowance. See EXTAL.

FAA, 3-10, 4-9

FAAD, 2-17

FAC, 3-72

family of scatterable mines. See FASCAM.

FARM, 3-63

FARP, 4-26, 5-2

FASCAM, 4-4, 4-6, 4-7

FFA, 4-9, 4-10

FFAR, 3-23, A-4, A-8, A-10

fire commands, 3-56

fire control, 3-46

firing position, 3-11

fire support. See FS.

fire support coordination line. See FSCL.

fire support officer. See FSO.

fire support team. See FIST.

FIST, 3-73

FLIR, 3-17, 3-50, 3-54, A-5

FLOT, 3-66

folding fin aerial rocket. See FFAR.

forward air controller. See FAC.

forward area air defense. See FAAD.

forward arming and refueling point. See FARP.

forward assembly area. See FAA.

forward line of own troops. See FLOT.

forward-looking infrared. See FLIR.

fragmentary order. See FRAGO.

FRAGO, 3-11, 3-65, D-3, D-13, 14, D-16

free cruise formation, 3-31

free-fire area. See FFA.

FS, 3-72, B-3, B-4, B-7

FSCL, 4-9, 4-10

fuel, ammunition (cannon), rockets, missiles. See FARM.

graduated response matrix. See GRM.

GRM, 6-4

ground support equipment. See GSE.

GSE, 5-2, 5-3

HA, 3-10,

Have Quick II, 2-16

HC, 4-5

Hellfire missile, A-4, A-6, A-12, F-15

hexachloroethane (smoke). See HC.

HF NOE COM, 2-16

high frequency nap-of-the-earth communications. See HF NOE COM.

holding area. See HA.

intelligence preparation of the battlefield. See IPB.

IPB, 2-7-2-9, 3-48, B-4

JAAT, 3-71, 3-72, 3-76

joint air attack team. See JAAT.

joint suppression of enemy air defense. See J-SEAD.

joint surveillance target acquisition radar system. See J-STARS.

J-SEAD, F-21

J-STARS, B-4

Kiowa Warrior. See KW.

KW, A-9, H-1-H-4

LADW, 4-16, 4-17

laser-guided bomb. See LGB.

laser range finder/designator. See LRF/D.

lead/wingman. See L/W.

LGB, 3-76

line formation, 3-33

local air defense warning. See LADW.

long-range surveillance detachment. See LRSD.

LRF/D, A-3, A-10

LRSD, B-2, B-3

L/W, 3-3 through 3-5, 3-31

maneuver control system. See MCS.

maneuver control system PHOENIX. See MCS-P.

main support battalion. See MSB.

FM 1-112

maintenance

- aircraft, 4-27
- armament, 5-4
- AVIM, 5-4
- AVUM, 5-3
- communications, 5-4,
- GSE, 5-2

march order, D-13

MCOO, 2-8

MCS, 2-16, 2-17

modified combined obstacle overlay. See MCOO.

MCS-P, 2-16

METT-T, F-17, H-2

MI, B-2, B-3

military intelligence. See MI.

mission, enemy, terrain, troops, and time available. See METT-T.

mobile subscriber equipment. See MSE.MSB, 5-1

MSE, 2-16

munitions, 4-5

NAVAIDS, 3-21, 4-29

navigational aids. See NAVAIDS.

NBC, 3-2, 4-19, 4-20, 4-26, 4-29

NBC weapons, 3-21

naval gunfire. See NGF.

NEO, 6-2

NFA, 4-8, 4-12

NGF, 4-7, 4-8,

noncombat evacuation operation. See NEO.

no-fire area. See NFA.

nuclear, biological, chemical. See NBC.

operations

- close, 1-7

- deep, 1-6, F-21, H-1, H-4

- rear, 1-8, F-25

- TMD, I-1

operation order. See OPORD.

operations other than war. See OOTW.

operations security. See OPSEC.

OPORD, C-2 through C-7, C-9 through C-20

OPSEC, 2-18

OOTW, 1-2

personnel services, 5-5 through 5-8

pilots night vision system/sensor. See PNVIS.

PNVS, A-6

QRF, 6-3, G-5

quick reaction force. See QRF.

rail movement, D-5

rally point, 3-14

reconnaissance and security, 3-68

release point. See RP.

restrictive fire area. See RFA.

restrictive fire line. See RFL.

RFA, 4-8, 4-9, 4-11

RFL, 4-8, 4-9, 4-11

road movement table, D-16

ROE, F-19

RP, D-19

rules of engagement. See ROE.

SAAFR, E-4

SALT, 4-7

SALUTE, 6-4

SASO

 employment guidelines, 6-1

 lessons learned, 6-3

 operational concept, 6-1

 principles, 6-1

 types of operations, 6-2

SBF, 3-11, 3-13, 3-41, 3-42,

SEAD, H-3, I-3

sealift, D-5

SERE, 3-27

show of force, 6-2

signal security. See SIGSEC.

signal operation instructions. See SOI.

SIGSEC, 2-18

SINCGARS, 2-17, E-7

single channel ground and air radio system. See SINCGARS.

SITREP, G-4

situation report. See SITREP.

size, activity, location, unit, time, and equipment. See SALUTE.

smoke and obscurants, 3-22

smoke operations, 4-28, 4-29

SOF, 6-3, I-6

SOI, E-7

SOP, E-1, I-5

special operations forces. See SOF.

FM 1-112

stability and support operations. See SASO.
staggered formation, 3-35
STANAG, D-10
standard-use Army aircraft flight route. See SAAFR.
standardization agreement. See STANAG.
standing operating procedures. See SOP.
strip map, D-15, D-19
supporting arms liaison team. See SALT.
support by fire. See SBF.
suppression of enemy air defense. See SEAD.
survival, evasion, resistance, and escape. See SERE.

TAADE, I-1, I-2
TAC CP, 2-13, 2-18
tactical command post. See TAC CP.
Tactical SOP
 format, E-1
 recommendations, E-1
tactics, techniques, and procedures. See TTP.
target location error. See TLE.
task force. See TF.
TBM, I-1, I-3, I-5, I-6
TCT, I-1, I-6
TDIS, D-11
TEL, I-3, I-6
TF, 3-1, 3-2, B-7
The Army Authorization Documents System. See TAADE.
theater ballistic missile. See TBM.
theater missile defense. See TMD.
time critical targeting. See TCT.
time-distance. See TDIS.
TLE, I-3
TMD
 attack operations, I-1
 purpose, I-1
 search and attack TTP, I-2
 targets, I-6
 TCT, I-1
 TMD operations, I-1
 threat TTP, I-1
TOW, 1-17, A-8, F-15
TP, 3-20
transporter erector launchers. See TEL.
TTP, 3-40, B-8, I-1, I-2
tube-launched, optically tracked, wire-guided. See TOW.
turn point. See TP.

unit movement

- airlift, D-4
- fundamentals, D-1
- ground convoy, D-6
- responsibilities, D-1
- planning, D-2
- rail, D-5
- references, D-23
- sealift, D-5
- security, D-19
- self-deployment, D-3
- training, D-22

video reconnaissance, 1-17

warning order. See WARNORD.

WARNORD, B-12, C-1

weapons control status. See WCS.

wedge formation, 3-36

WCS, 4-18, F-24

FM 1-112
2 April 1997

By Order of the Secretary of the Army:

DENNIS J. REIMER
General, United States Army
Chief of Staff

Official:

JOEL B HUDSON
Acting Administrative Assistant to the
Secretary of the Army
03152

DISTRIBUTION:

Active Army, Army National Guard, and U.S. Army Reserve: To be distributed in accordance with initial distribution number 110712, requirements for FM 1-112.