

*2 rec'd  
1-MR*

ENGINEERING DESIGN HANDBOOK

EXPLOSIVES SERIES

EXPLOSIVE TRAINS



HEADQUARTERS  
UNITED STATES ARMY MATERIEL COMMAND  
WASHINGTON, D.C. 20315

9 March 1965

AMCP 706-179, Explosive Trains, forming part of the Explosives Series of the Army Materiel Command Engineering Design Handbook Series, is published for the information and guidance of all concerned.

(AMCRD)

FOR THE COMMANDER:

SELWYN D. SMITH, JR.  
Major General, USA  
Chief of Staff

OFFICIAL:



STANLEY J. SAWICKI  
Colonel, GS  
Chief, Administrative Office

DISTRIBUTION: Special

## PREFACE

The Engineering Design Handbook Series of the Army Materiel Command is a coordinated series of handbooks containing basic information and fundamental data useful in the design and development of Army materiel and systems. The handbooks are authoritative reference books of practical information and quantitative facts helpful in the design and development of Army materiel so that it will meet the tactical and the technical needs of the Armed Forces. The present handbook is one of a series on explosives.

This handbook presents theoretical and practical data pertaining to explosive trains. It includes consideration of the various elements which, in considerable variation, may constitute the explosive train of an item. The main charge of an explosive item, such as projectile or warhead filler, is also covered. Data are given on the physical and explosive characteristics of typical explosives and references are cited in which additional data will be found.

Coverage includes development of the complete explosive train, from elements suitable for initiation of the explosive reaction to the promotion of effective functioning of the final output element. The nature of the explosive reaction, method of transfer of detonation and measurement of output are discussed. Design principles and data pertaining to primers, detonators, delay elements, leads, boosters, main charges and specialized explosive elements are covered. The effects of environmental conditions and steps to be taken to avoid difficulties are discussed.

This handbook has been prepared as an aid to ammunition designers. It should also be of benefit to scientists and engineers engaged in research and development programs or who have responsibility for the planning and interpretation of experiments and tests relating to the performance of ammunition or ammunition components.

The handbook was prepared by The Franklin Institute, Philadelphia, Pennsylvania, based on a manuscript prepared by Armour Research Foundation of the University of Illinois Institute of Technology. The handbook was prepared for the Engineering Handbook Office of Duke University, prime contractor to the Army Research Office-Durham. The Explosive Series is under the technical guidance and coordination of a special committee with representation from Picatinny Arsenal and Frankford Arsenal of the Munitions Command, and the Ballistic Research Laboratories. Chairman of this committee was Mr. Donald Seeger of Picatinny Arsenal.

Elements of the U. S. Army Materiel Command having need for handbooks may submit requisitions or official requests directly to Publications and Reproduction Agency, Letterkenny Army Depot, Chambersburg, Pennsylvania 17201. Contractors should submit such requisitions or requests to their contracting officers.

Comments and suggestions on this handbook are welcome and should be addressed to Army Research Office-Durham, Box CM, Duke Station, Durham, North Carolina 27706.

# TABLE OF CONTENTS

	<i>Page</i>
PREFACE .....	i
LIST OF ILLUSTRATIONS.....	vii
LIST OF TABLES.....	ix
LIST OF SYMBOLS .....	x
 <b>PART ONE—FUNDAMENTAL PRINCIPLES</b>	
<b>CHAPTER 1. EXPLOSIVE CHARGES AS COMPONENTS OF WEAPON SYSTEMS</b>	
A. Introduction	
1. Purpose.....	1
2. The Explosive Train.....	1
3. Bases for Selecting Explosive Charges.....	3
B. Systems Approach to Ammunition	
4. Vehicular Aspects.....	4
5. Structural Aspects.....	6
6. Mechanical Aspects.....	7
7. Electrical Aspects .....	9
C. General Design Considerations	
8. Economics .....	9
9. Reliability .....	10
10. Safety.....	10
11. Standardization .....	11
12. Information Sources .....	11
 <b>CHAPTER 2. EXPLOSIVE REACTIONS AND INITIATION</b>	
A. Thermal Decomposition and Burning	
13. Thermal Decomposition.....	13
14. Reaction Kinetics.....	13
15. The "Hot Spot" Theory of Initiation.....	15
16. Deflagration .....	16
B. Detonation	
17. Transition from Deflagration to Detonation .....	17
18. Shock Waves.....	19
19. Detonation Waves.....	20
C. Initiation	
20. Establishing a Self-Propagating Reaction.....	23
21. Initiation by Heat.....	25
22. Initiation by Impact.....	28
23. Initiation by Other Means.....	29
References.....	32
 <b>CHAPTER 3. DETONATION TRANSFER AND OUTPUT</b>	
A. Effectiveness of One Charge in Initiating Another	
24. Detonation Propagation.....	33
25. Dimensional Interactions.....	34

## TABLE OF CONTENTS (Continued)

	<i>Page</i>
B. Sensitivity to Initiation	
26. Sensitivity Tests .....	35
27. Variables Affecting Sensitivity.....	37
28. Misaligned Charges .....	40
C. Output	
29. Nature of Explosive Output.....	41
30. Effect of Charge Configuration .....	41
31. Blast .....	42
32. Fragmentation .....	44
33. Other Effects.....	45
References.....	47
CHAPTER 4. ENVIRONMENTAL RESPONSE	48
34. Military Requirements.....	48
A. Temperature	
35. High Temperature Storage.....	49
36. Cook-Off .....	51
37. Other Effects of High Temperature Use.....	53
38. Low Temperature Storage and Use.....	54
B. Environment	
39. Chemical Interactions .....	55
40. Simulation of Impact.....	57
41. Setback Acceleration.....	58
42. Other Effects.....	59
References.....	61
PART TWO—DESIGN CONSIDERATIONS	62
43. Introduction .....	62
CHAPTER 5. PRIMERS AND DETONATORS	
A. Description and Selection	
44. Function and Construction.....	62
45. Initiator Types.....	63
46. Bases for Selecting an Initiator Type.....	65
B. Input Characteristics	
47. Stab Initiators.....	66
48. Percussion Primers.....	66
49. Flash Detonators .....	67
50. Electric Initiators .....	67
C. Output Characteristics	
51. Output of Primers .....	72
52. Output of Detonators.....	73
D. Construction and Fabrication	
53. Initiator Cups .....	75
54. Explosive Loading.....	77
55. Mechanical Initiators .....	77
56. Electric Initiators .....	77
References.....	79

## TABLE OF CONTENTS (Continued)

	<i>Page</i>
<b>CHAPTER 6. DELAY ELEMENTS</b>	
A. Description	
57. Function and Construction.....	80
58. Delay Types.....	80
59. Relays.....	82
B. Delay Compositions	
60. Gas Producing Delay Charges.....	82
61. Gasless Delay Charges .....	84
C. Design Principles	
62. Obturated vs. Vented Design .....	87
63. Design Rules of Thumb.....	87
References.....	88
<b>CHAPTER 7. LEADS AND BOOSTERS</b>	
A. Description	
64. General .....	89
65. Functions .....	89
66. Explosives .....	90
B. Design Considerations	
67. Relation to Fuze Design.....	92
68. Leads.....	92
69. Boosters .....	93
70. Charge Density Effects .....	94
71. Output Wave Profile .....	95
C. Construction and Fabrication	
72. Loading Techniques.....	96
73. Short Leads.....	96
74. Long Leads.....	97
75. Boosters .....	98
References.....	99
<b>CHAPTER 8. MAIN BURSTING CHARGE</b>	
A. Description	
76. Function.....	100
77. Typical Main Bursting Charges.....	100
78. Size and Weight .....	102
B. Initiation	
79. Sensitivity.....	102
80. Explosive Loading.....	103
81. Booster Position.....	103
82. Auxiliary Boosters and Boosted Surrounds.....	103
83. Confinement.....	103
References.....	104
<b>CHAPTER 9. OTHER EXPLOSIVE CHARGES</b>	
A. Actuators	
84. Description .....	105
85. Output Characteristics .....	106

## TABLE OF CONTENTS (Concluded)

	<i>Page</i>
B. Demolition Devices and Accessories	
86. Destructors.....	106
87. Explosive Tubes and Sheets.....	107
88. Demolition Blocks.....	107
89. Explosive Bolts.....	108
References.....	108
CHAPTER 10. LOADING AND FABRICATION	
90. Process Selection.....	109
A. Casting	
91. Projectile Preparation.....	109
92. Effect of Casting Procedure on Charge Characteristics ...	109
93. Standard Casting Procedure.....	110
94. Some Special Casting Techniques.....	110
B. Pressing	
95. Standard Procedures.....	111
96. Special Procedures.....	116
C. Finishing Operations	
97. Machining.....	117
98. Cementing of Compound Charges.....	118
D. Suitability	
99. Availability.....	118
100. Output Characteristics.....	119
101. Sensitivity.....	119
102. Chemical and Physical Properties.....	120
E. Quality Control	
103. Bases for Tolerances.....	121
104. Factors Affecting Quality of Explosive Charges.....	121
References.....	122
CHAPTER 11. EVALUATION PROCEDURES	
A. Considerations in Evaluation	
105. Safety and Reliability Criteria.....	123
106. Statistical Test Methods.....	127
B. Testing Techniques	
107. Explosive Materials.....	128
108. Input.....	133
109. Output.....	135
110. Environment.....	136
References.....	139
GLOSSARY OF KEY TERMS.....	140
INDEX.....	142

## LIST OF ILLUSTRATIONS

<i>Figure</i>	<i>Page</i>
1 Typical Explosive Train.....	2
2 Computed Explosive Reaction Rates .....	14
3 Arrangement Used in Observations of Detonation Growth.....	17
4 Formation and Incipient Decay of Shock Wave from Wave of Finite Amplitude .....	21
5 Energy-Power Relationship for Various Initiators .....	24
6 Typical Effect of Bridgewire Volume on Input Characteristics.....	25
7 Threshold Conditions for Initiation of Various Explosives in a Shock Tube .....	27
8 Input Sensitivity vs. Explosion Temperature .....	28
9 Standard Firing Pin for Stab Initiators.....	29
10 Energy-Velocity Relationship for Percussion Primers .....	30
11 Streak Camera Record of Detonation .....	33
12 Critical Gap as a Function of Column Diameter.....	34
13 Critical Axial Air Gaps Across Which Detonation Is Transmitted Between Lead Azide and Tetryl.....	35
14 Small Scale Air Gap Test .....	35
15 Minimum Priming Charge and Gap for Critical Propagation .....	36
16 Small Scale Lucite Gap Test.....	37
17 Effect of Voids on Booster Sensitivity (Wax Gap Test).....	38
18 Effect of Voids on Booster Sensitivity (Lucite Gap Test).....	38
19 Effect of Acceptor Confining Material upon Sensitivity in an Air Gap Test .....	39
20 Gap Sensitivity Related to Density and Hardness of Acceptor Confining Medium.....	40
21 Arrangement for Propagation of Misaligned Charges .....	41
22 Line Wave Generator of the Manifold Type.....	42
23 Line Wave Generator of Sheet Explosive .....	42
24 Line Wave Generator of Warped Sheet of Explosive.....	43
25 Pressure-Time Relationship of Explosive Blast.....	43
26 Postulated Condition for Initiator Failure Caused by Wire-Explosive Separation.....	51
27 Test of a Booster in Simulated Missile Flight .....	52
28 Cook-Off Characteristics of Three Explosives .....	53
29 Apparatus for Simulating Aerodynamic Heating.....	54
30 Simulated Aerodynamic Heat Test .....	55
31 Typical Time-Acceleration Curve for Projectile While in Gun.....	58
32 Typical Primers and Detonators (Mechanical) .....	63
33 Typical Primers and Detonators (Electrical).....	64
34 Electric Squib (M2) .....	64
35 Stab-Electric Detonator (T29).....	64
36 Functioning Times of Hot Wire Bridge Initiators .....	70
37 Coined Bottom Cup.....	76
38 Punch Trimming of Initiator Cups .....	76
39 Initiator Cup Crimping.....	76
40 Obturated Delay Element of Bomb Fuze ANM100A2.....	81
41 Electric Delay Detonator (MARK 35 MOD 1) .....	81
42 Electric Delay Detonator (T65) .....	82
43 Sealing Methods for Vented Delays.....	82
44 Fuze M54.....	82



## LIST OF ILLUSTRATIONS (Concluded)

<i>Figure</i>	<i>Page</i>
45 Pressure Type Delay.....	83
46 Typical Explosive Relays.....	83
47 Support of Delay Pellet.....	84
48 Characteristics of an Obturated Black Powder Delay Element.....	85
49 Booster (M21A4).....	90
50 2.75-in. HEAT Rocket with Spit-Back Explosive System.....	90
51 20mm Fuze (M505).....	91
52 Critical Conditions for Detonation of Lead.....	93
53 Lead Pellets Held in Place by Staked-in Closure Disk.....	96
54 Lead Retained by a Feature of Fuze Design.....	96
55 Lead Retained by a Cup.....	97
56 Explosive Loaded by Breaking off Excess.....	97
57 Lead End Coated with Sealant.....	97
58 Lead Cup Crimped in Place.....	97
59 Chamfered Booster Pellet.....	98
60 Improper Charging of Cup.....	98
61 High Explosive Projectile.....	101
62 Armor Piercing Projectile.....	101
63 General Purpose Bomb.....	101
64 Antitank Mine (M15).....	101
65 High Explosive Antitank Projectile.....	101
66 Burst Type Chemical Projectile.....	101
67 Dimple Motor (T3E1).....	105
68 Bellows Motor (T5E1).....	105
69 Piston Motor.....	105
70 Multiple Contact Switch.....	106
71 Pyroswitch.....	106
72 Universal Destructor (M10).....	107
73 Explosive Bolt in Which Reflected Tension Waves Are Utilized.....	108
74 Vacuum Casting Kettle.....	111
75 Scoop Loading.....	112
76 Charging Plate Loading.....	112
77 Detonator Loading Tool.....	112
78 Tool for Direct Loading of Component.....	113
79 Nomograph of Loading Pressure-Density.....	114
80 Pelleting Presses.....	115
81 Vacuum Pressing Apparatus.....	116
82 Hydrostatic Press Principle.....	117
83 Isostatic Press Principle.....	117
84 Cumulative Frequency Distribution for a Normally Distributed Population.....	124
85 Skewed Frequency Distribution Typical of Impact Sensitivity Data.....	125
86 Picatinny Arsenal Impact Test Apparatus.....	129
87 Booster Sensitivity Test (Wax Gap).....	130
88 Apparatus Which Simulates Setback Pressure.....	131
89 Method of d'Autriche for the Measurement of Detonation Velocity.....	132
90 Typical Condenser Discharge Firing Circuit for Testing Electric Initiators.....	133
91 Principle of Hopkinson Bar Measurement of Detonator Output.....	135
92 Arrangement for Detonator Safety Test.....	138

## LIST OF TABLES

<i>Table</i>	<i>Page</i>
1 Values of Acceleration in Ammunition.....	6
2 Ignition and Explosion Temperatures.....	15
3 Values of the Constant <i>G</i> in Equation 6.....	17
4 Optimum Loading Densities and Particle Sizes for Growth of Detonation in RDX, HMX and PETN .....	18
5 Detonation Velocity Constants for Equation 20.....	22
6 Detonation Conditions, Calculated and Measured .....	22
7 Sensitivity of Various Explosives in Wire Bridge Initiators.....	26
8 Effect of Loading Pressure on Initiator Sensitivity.....	29
9 Initiation of Explosion by Friction of PETN in the Presence of Grit	30
10 Threshold Ignition Energies.....	31
11 Densities and Shock Velocities in Various Metals.....	35
12 Typical Results of Booster Sensitivity Test.....	36
13 Initiation Sensitivity Measured by Several Tests.....	36
14 Relation of Decibangs to Gap Thickness .....	37
15 Sensitivities of Some Explosives According to the Small-Scale Lucite Gap Test.....	37
16 Effect of 5 Percent D-2 Wax on the Booster Sensitivity of Various Cast Explosives (Wax Gap Test).....	39
17 Air Gap Sensitivity Related to Acoustic Impedance of Acceptor Confining Medium.....	39
18 Sensitivity for Various Spacer Materials (Wax Gap Test).....	40
19 Gurney Constant for Common Explosives.....	44
20 Relative Sensitivities of Explosives According to Standard Laboratory Tests of Ground Samples.....	49
21 Sensitivity of Explosives to Hazards of Use.....	50
22 Cook-Off Tests of Standard and Modified M47 Detonators .....	53
23 Compatibility of High Explosives with Metals and Miscellaneous Materials.....	56
24 Bullet Sensitivity of 50/50 Pentolite.....	57
25 Critical Setback Pressures of Explosives of Various Size Base Separations.....	58
26 Data Obtained from Explosives After Exposure to Gamma Radiation	60
27 Common Priming Compositions .....	66
28 Effect of Sealing Cup or Disk on Sensitivity.....	66
29 Resistivities of Bridgewire Materials.....	68
30 Firing Times of Hot Bridgewire Initiators.....	70
31 Heats of Explosion and Detonation Pressures .....	74
32 Gasless Delay Compositions in Current Use.....	84
33 Ignition Powders for Gasless Delay Elements.....	84
34 Burning Rates of Gasless Delay Compositions .....	86
35 Effect of Loading Pressure on BaCrO <sub>4</sub> -B Compositions .....	87
36 Failure Diameters of Lead and Booster Explosives .....	93
37 Loading Density of Various Explosives.....	113
38 Fundamental Characteristics of Explosive Compounds .....	120
39 Fundamental Characteristics of High Explosive Mixtures.....	120
40 Safety and Reliability Related to Deviations from the Mean .....	126
41 MIL-STD Tests for Fuzes.....	137

## LIST OF SYMBOLS

<i>A</i>	constant	<i>m</i>	mass
<i>a</i>	acceleration	<i>n</i>	number
<i>B</i>	Brinell hardness	<i>n</i>	polytropic exponent
<i>B</i>	constant	<i>P</i>	pressure
<i>C</i>	capacitance	<i>R</i>	burning rate
<i>C</i>	heat capacity	<i>R</i>	resistance
<i>C<sub>p</sub></i>	thermal mass	<i>R</i>	universal gas constant
<i>c<sub>o</sub></i>	velocity of sound	<i>r</i>	radius
<i>D</i>	detonation velocity	<i>r<sub>w</sub></i>	resistivity
<i>d</i>	depth of dent	<i>T</i>	temperature
<i>d</i>	diameter	<i>T<sub>s</sub></i>	stagnation temperature
<i>E</i>	modulus of elasticity	<i>t</i>	time
<i>E</i>	voltage	<i>u</i>	particle velocity
$\sqrt{2E}$	Gurney constant	<i>V</i>	voltage
<i>F</i>	constant	<i>V</i>	volume
<i>G</i>	constant	<i>v</i>	velocity
<i>G</i>	gap	<i>w</i>	energy
<i>g</i>	acceleration of gravity	<i>W</i>	weight
<i>H</i>	agitational energy	<i>X</i>	sensitivity stimulus in decibang units
<i>I</i>	current	<i>y</i>	thickness
<i>K</i>	constant	$\alpha$	covolume of gas
<i>k</i>	thermal conductivity	$\gamma$	cooling rate coefficient
<i>k'</i>	reaction rate	$\gamma$	failure rate
<i>L</i>	inductance	$\gamma$	ratio of specific heats
<i>L</i>	length	$\rho$	density
<i>M</i>	Mach number		

## SUBSCRIPTS

<i>c</i>	case, charge	<i>o</i>	reference condition
<i>d</i>	delay composition	<i>p</i>	priming composition
<i>f</i>	firing temperature	<i>r</i>	recovery, reference
<i>i</i>	insulation	<i>s</i>	short
<i>l</i>	long	<i>t</i>	threshold, test
<i>m</i>	metal		

# EXPLOSIVE TRAINS\*

## PART ONE — FUNDAMENTAL PRINCIPLES

### CHAPTER 1

## EXPLOSIVE CHARGES AS COMPONENTS OF WEAPON SYSTEMS

### A. INTRODUCTION

#### 1. Purpose

This handbook is one in the series of Engineering Design Handbooks dealing with explosives. It covers the principles and factors applicable to the design of the various individual elements which are parts of an explosive train. These elements include primers, detonators, relays, delays, leads, boosters and main bursting charges. In addition, principles and factors involved in the design of explosive items such as actuators, explosive switches and destructors, which are usually not elements of the main explosive train of a military item, are mentioned, particularly where the principles differ from those applicable to the main train.

The phenomena of initiation, deflagration and detonation and their interaction with effects produced in surrounding materials are discussed with particular emphasis on those aspects which are important to designers of explosive charges. Also discussed are evaluation procedures, loading methods, and the effects of design upon the probability of accidental initiation, upon reliability, and upon the useful life of an item.

#### 2. The Explosive Train

An explosive train is an assembly of explosive elements arranged in order of decreasing sensitivity. The function of the explosive train is to accomplish the controlled augmentation of a small impulse into one of suitable energy to cause the main charge of the munition to function.

---

\* Prepared by Gunther Cohn, Laboratories for Research and Development of The Franklin Institute, based on a manuscript written by R. H. Stresau for Armour Research Foundation of the Illinois Institute of Technology.

Explosive trains may be divided into two general classes, *high explosive trains* and *low explosive trains*, according to the type of explosive used in the main charge.† An explosive train may also be designated according to the item in which it is assembled or to which it pertains. One of the most common examples of the high explosive trains is the *fuze explosive train*. If the bursting charge is added, it is commonly called a *bursting charge explosive train*. A common example of the low explosive train is the *propelling charge explosive train*.

Propelling charge explosive trains and other low explosive trains are covered in other handbooks of the Series. Unless otherwise indicated, the term *explosive train* in this handbook signifies a *high explosive train*.

The explosive or combustible elements of a fuze explosive train are so arranged that

- (a) they can be activated in the desired manner,
- (b) on functioning, they will produce the desired effect reliably, and
- (c) the probability of premature functioning is minimized for all foreseeable conditions of handling, storage, transport and use.

Essential elements of such an assembly are generally

- (a) A primary or low explosive charge, contained in a suitable housing, that is capable of (1) being activated by a relatively small stimulus (mechanical or electrical) and (2) producing a self-propagating reaction. The output of this initial charge consists principally of relatively low velocity hot gases and particles.

---

† For more detailed definitions of explosive material, see the Glossary at the end of this handbook.

(b) An intermediate charge of primary high explosive (most commonly lead azide) in which the transition from burning to detonation takes place.

(c) A secondary high explosive charge (for example, RDX) that intensifies the shock output from the intermediate charge, and

(d) A main charge consisting of a secondary high explosive (for example, TNT) that produces the desired effect.

Auxiliary elements which are almost always included in an explosive train for convenience of design and for special purposes are

(a) Leads and relays to transmit explosive reactions between spatially separated elements,

(b) Delay or time element to increase the interval between activation of the first explosive element and functioning of the main charge, and

(c) A booster which is sensitive enough to be initiated by relatively small output of a secondary high explosive charge and powerful enough to initiate the insensitive secondary high explosive usually used for the main charge.

A number of auxiliary elements are used in some ordnance items which are complete explosive trains in themselves to accomplish specific tasks

- (a) Actuators
- (b) Explosive bolts
- (c) Destructors

Note that the foregoing description applies mainly to the most common explosive train, namely one resulting in high explosive functioning. Where the output is nonexplosive, the train is essentially the same through initiation and auxiliary components. However, the explosive train usually never proceeds beyond the burning stage initiated by the primer charge. Examples of such nonexplosive applications are signal flares, smoke bombs, propellant systems, parachute packs and leaflet bombs.

Figure 1 shows a simple explosive train. Pictured in schematic form is the M505 nose fuze which is used with 20mm ammunition. The fuze is shown in both armed and unarmed conditions but details of mechanical construction have been omitted. While important, these features are beyond

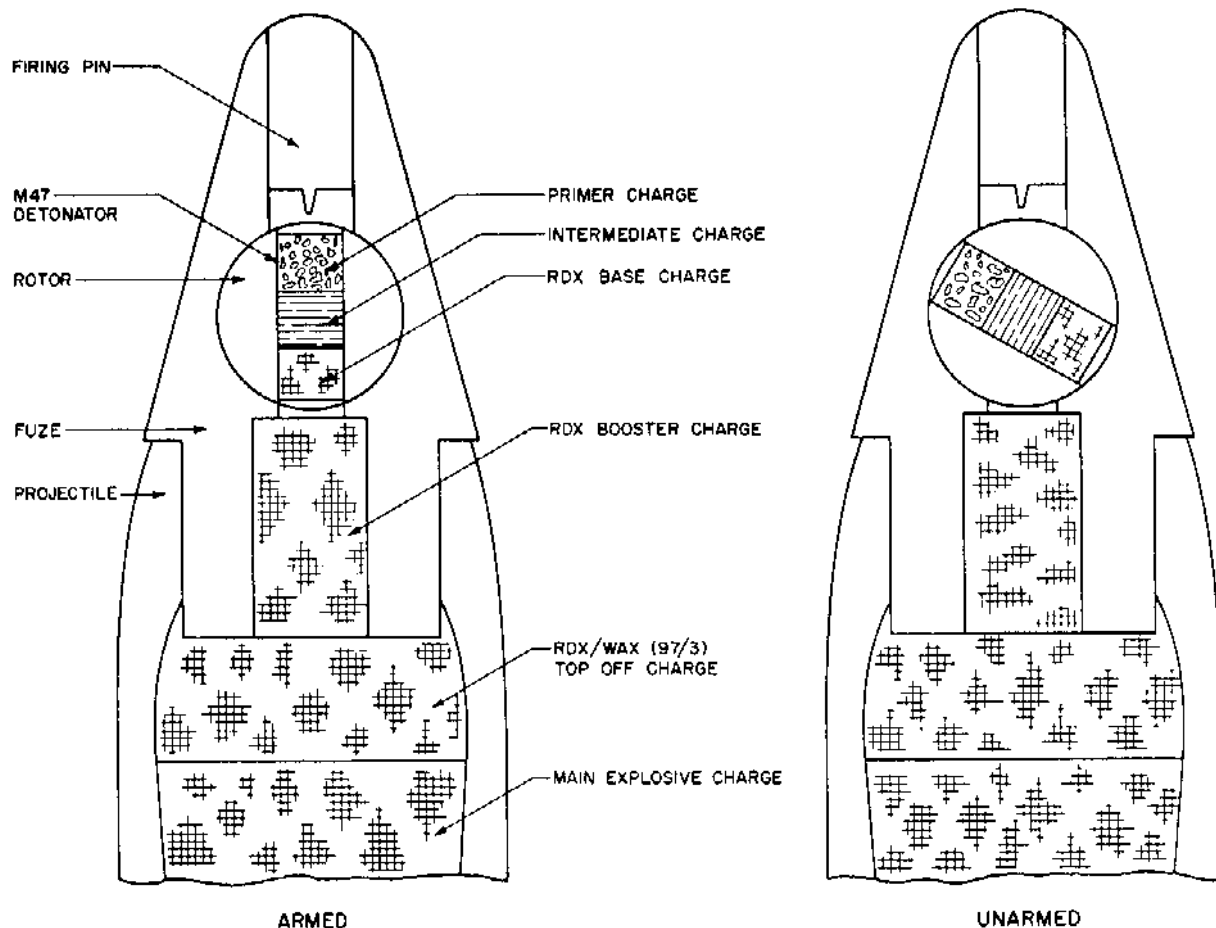

Figure 1. Typical Explosive Train

the scope of this handbook (for an assembly drawing of this fuze, see Fig. 51).

In the armed condition, the fuze is ready to function. When it strikes the target, the following sequence of actions take place

(a) The stab firing pin strikes the input end of the M47 detonator, piercing the thin metal disk and pushing into the primer charge. This stabbing causes a reaction to be initiated in the primer charge.

(b) The primer charge initiates the intermediate charge of lead azide which is also contained in the detonator. Here the action is accelerated and converted to a detonation.

(c) The detonation of the lead azide is transmitted to the RDX base charge of the detonator and is amplified.

(d) The RDX booster and top off charges serve to amplify the detonation wave to insure proper initiation of the main charge in the projectile.

In a superquick fuze, such as this one, this entire sequence takes place in only a few microseconds, whereas in a fuze having delayed action, the interval between activation of the primer charge and explosion of the main charge may be as much as several hundred milliseconds. Such a delay may be introduced by a special pyrotechnic charge, which burns at a definite rate, between primer and intermediate charges.

The rotor in which the detonator is assembled is aligned with the remainder of the explosive train through the action of linear and rotational forces encountered during propelling the projectile from the gun. In the unarmed view (Fig. 1) the fuze is in the *safe* or out-of-line position. The purpose of this safety feature of fuzes is to isolate physically the more sensitive explosives of the explosive train from the main charge. Since the more sensitive explosives are more susceptible to accidental initiation, they will not propagate to the main charge, if initiated, when they are in the out-of-line position.

### 3. Bases for Selecting Explosive Charges

When the designer is ready to build an explosive train, he must make a variety of decisions. Before he can select the explosive charges, he must have a clear idea of the input stimulus that will be used to start his system and of the final output the system is to have. Between these two extremes, he must assemble a variety of explosive components. This complete system will then make up the explosive train.

Since the objective of the explosive train is to function the main bursting charge, it is logical to consider it first. This charge is designed so as to deliver the output which is required of the ammunition. While the output is invariably specified for all design requirements, it is usually given in terms which the explosive charge designer cannot use directly.

Specifications start with the user who has a requirement. For example, the user may want to defeat a tank, to cause personnel casualties or to produce a signal. Next, the ammunition designer translates these needs into terms of specific ammunition. He may call for a 90mm HEAT round to be fired from a recoilless rifle, a nonmetallic mine to be triggered by foot pressure, or a marker projectile delivering a red smoke puff lasting for 20 seconds. At this point, the explosive charge designer takes over. He will specify the weight and configuration of the main high explosive charge in the HEAT projectile, the amount of charge in the mine and, together with the ammunition designer, will fix the size of the mine to result in the desired effects, or he will specify the weight and configuration of the HE booster charge and the composition of the chemicals to produce the smoke puff.

Where the design calls for high explosives in a projectile, bomb, or the like for which caliber is either specified or the shape of which is fixed by ballistic considerations, the task of designing the output charge is fairly straightforward. The given container is filled with as much explosive as will fit. Seventy percent of the total weight of a light-case bomb, for example, is high explosive filler. Design principles for blast (Paragraph 31) and for fragmentation (Paragraph 32) are well established. Explosives for chemical charges must burst the case and disseminate the contents efficiently. The design of main charges is discussed in Paragraphs 76 to 83.

At the other end of the train is the initiator. Selection and design of the proper first element in the explosive train is probably the most difficult step. For this reason, this subject is treated in depth by itself (Paragraph 46). The design of initiators is covered in Paragraphs 44 to 56.

It is a basic safety requirement in almost all ammunition that the initiator be kept out of line so that the train will not propagate in the event of accidental functioning of the sensitive initiator. While the explosive charge designer is definitely concerned with such safety devices, they are not included in this handbook. The design, construc-

tion, layout, and evaluation of the various safety and arming devices are covered in texts on fuze design.

The next element to be considered is the booster charge. Most high explosive ammunition has boosters. The booster is that charge which is sensitive enough to be actuated by the small explosive elements on the one hand and powerful enough to cause detonation of the main explosive on the other hand. Tetryl and RDX are common explosives which have these properties. The booster charge is best placed into a cavity of the main charge (the fuze well). The design of boosters is covered in Paragraphs 64 to 75.

From the standpoint of train propagation, a booster pellet is all that is required. However, for reasons of safety and versatility, some military ammunition calls for a complete booster containing its own detonator and out-of-line arming device. This secondary train is designed in the same manner as the main train.

So far, we have considered main charges and boosters at the output end and initiators at the input end. These three form the basic elements required in every train. If the explosive train is for a small device, no additional charges are necessary. Additional charges are added only to fill a particular need.

If there is to be a time interval between initiation and functioning of the train, a delay element is inserted. Often a relay is required at the end of the delay to transform the deflagration of the burning delay into a detonation wave. Delay elements are described in Paragraphs 57 to 63.

A common explosive train charge is the lead. Because of the geometry required to achieve bore safety, detonator (or relay) and booster are separated too far for the detonation wave to travel. This gap is filled with a lead. Leads contain the same explosives as boosters. Leads are covered in Paragraphs 64 to 75.

Sometimes functions other than initiation of the main charge are required. Actuators exert a force through a small distance to activate controls or to close switches. Small and reliable, they are ideally suited for remote control. Explosive bolts and destructors are other examples of devices serving auxiliary functions. These designs are covered in Paragraphs 84 to 89.

Good design practice must be applied to all explosive charges and to their assembly into a train. Charges must be of the proper geometry and sensitivity and must have the correct density and confinement as discussed in Paragraphs 24 to 28. They

must be compatible with other explosives and with metal parts. They must be safe to handle and must stand the extremes of temperature in storage and use as discussed in Paragraphs 34 to 42. The design of explosive charges which make up safe and reliable trains has not yet been reduced to a formula. Rather, it requires considerable experience. The design of unusual trains, in particular, should never be attempted by a novice.

After the design is completed, the train is ready for thorough test and evaluation as discussed in Paragraphs 105 to 110.

## B. SYSTEMS APPROACH TO AMMUNITION

### 4. Vehicular Aspects

*a. General.* Most ammunition is projected to its target over appreciable distances. Both maximum velocities and ranges continue to increase with improvements in propellants and design. Four aspects of this motion must be considered by the designer of explosive charges.

(a) Range and accuracy of a round depend upon its aerodynamic characteristics. The external contours dictated by aerodynamic considerations are a limitation upon size and shape of the explosive system.

(b) It is sometimes necessary to adapt the design of explosive charges in order to distribute the weight properly for flight stability.

(c) Velocities and flight times of many modern missiles are such that aerodynamic heating has introduced a whole new set of explosive-charge-design problems.

(d) Acceleration forces during launching, flight and impact are the principal sources of the structural loading of ammunition.

In addition to these more or less general consequences of the functioning of military items as vehicles, it is necessary for the designer of explosive charges to consider special circumstances which may arise as a result of transport systems. Accelerations due to the mechanical action of rapid-fire guns and launchers are sometimes quite appreciable and have been known to produce undesirable results when they were not taken into consideration during design. Chambers of rapid-fire weapons are heated in the course of long bursts to temperatures which can cause functioning of rounds that remain in them when firing stops.

The limitations on explosive charge design imposed by the first two aspects listed above are

those of dimension and spatial configuration. They are usually clearly stated in design specifications or military requirements for explosive charges. Effects of aerodynamic heating and acceleration forces, however, are not usually obvious from a glance at the drawings. Frequently, they can influence the functioning of ammunition.

*b. Aerodynamic Heating.* Not only must an explosive system withstand high temperatures without premature functioning, it must also function effectively and reliably during or after such exposure. Insulation of explosive charges can be quite effective because the exposure time is usually so short that, with reduced heat transfer rates, the heat capacity of the explosive is sufficient to keep the temperature within bounds. However, as velocities and ranges continue to increase, the necessary amount of insulation may increase to a point where it seriously reduces the effectiveness of a warhead, both by displacing explosive and by wrapping it in a highly effective shock attenuator. The effects of high temperatures upon explosives are discussed in more detail in Paragraphs 35-37. Some of the newer explosives which are more heat resistant are not castable. The use of these materials will necessitate design changes in the carrier to facilitate either (a) consolidation of the explosive charge or (b) assembly of preformed explosive charges.

The determination of temperature profiles within ammunition items affected by aerodynamic heating is difficult, complex, and quite beyond the scope of the present discussion. It is, however, frequently possible for a designer, by means of a few quick calculations using a simplified model of his system, to obtain a gross answer regarding the need for more detailed calculations, the substitution of explosives, or the insulation of explosive charges. The following discussion is intended as an aid in making such approximate calculations.

The flow conditions about an object moving through the atmosphere are most simple if they are considered in terms of a coordinate system moving with the object. In such a system, the undisturbed air is an infinite stream moving at a velocity of magnitude equal to that of the object in a system of fixed coordinates. Quite clearly, the object impedes this flow of air. By Bernoulli's principle (conservation of momentum) any reduction of the velocity of part of the stream must be accompanied by an increase in pressure. Rapid compression of a gas causes its temperature to rise. The highest temperature which may be anticipated in any point in such a

system, called the stagnation temperature, is that of air which has been brought to rest with respect to the object. The formula for the calculation of difference between the stagnation temperature  $T_s$  is

$$T_s = T_o(1 + 0.2M^2) \quad (1)$$

where  $T_o$  is the temperature of the undisturbed atmosphere and  $M$  is the Mach number. Temperatures are in °K.

If the stagnation temperature is below that at which the explosive charge will suffer any ill effects, as discussed in Paragraphs 36-37, there is no problem of aerodynamic heating.

A stagnation temperature high enough to have deleterious effects upon the explosive is not necessarily reason to take special measures. Only a small fraction of the surface of a moving object is exposed to air at the stagnation temperature. The boundary layer of air in contact with the surface at points where there is an appreciable tangential flow component approaches a recovery temperature which is well below the stagnation temperature. Typical relationships of recovery temperatures  $T_r$  to stagnation temperatures are

$$\frac{T_r - T_o}{T_s - T_o} = 0.8 \text{ to } 0.9 \quad (2)$$

The value of this ratio varies with velocity, position, and shape of the object.

Most ammunition which flies at speeds at which the stagnation temperature of atmospheric air is sufficient to have undesirable effects upon explosives does so for a limited time. The question as to whether the explosive materials will reach undesirably high temperatures during such an interval can be answered only by considering the heat flow into and within each component in detail.

As the stagnation temperatures rise relative to those at which explosives are stable and as designs become more intricate, the means of resolving doubts regarding whether explosive charges will survive aerodynamic heating become more laborious and less positive. The introduction of a heat barrier may turn out to be the only way in which these doubts may be removed. In some cases a simple barrier will not only be effective in protecting the explosive but it will also reduce the heat transfer analysis to simple arithmetic. For example, if a thin layer of insulation is applied to the outside of the metal case of an explosive charge, it may be assumed as a first approximation that the metal loses no heat to the explosive, that the surface coefficient of heat transfer is infinite, and that the



heat capacity of the insulation is negligible. If these assumptions are made, then the heating rate of the case is

$$dT_c/dt = (T_r - T_c)k_i/y_i y_c C_c \rho \quad (3)$$

where  $T_c$  is the temperature of the case,  $T_r$  is the reference temperature,  $k_i$  is the thermal conductivity of the insulation,  $y_i$  is the thickness of the insulation,  $y_c$  is the thickness of the case,  $\rho$  is the density of the case material, and  $C_c$  is the heat capacity of the case material. It will be noted that all of the assumptions are conservative in the sense that they tend to make the calculated temperature rise more rapid than the real one. Thus, if these calculations lead to the conclusion that the protection against aerodynamic heating is adequate, it may be accepted with a minimum of doubt.

Where the combination of temperature, time, space, and weight limitations result in inadequate protection of explosive materials, the use of heats of evaporation and fusion to increase the effective capacity of heat sinks has been suggested. Both the fusion of low melting alloys and the dehydration of hydrated salts have been suggested as thermal buffers. Some salts have the added virtue of expanding with dehydration to form porous insulation media.

A reasonable course for an explosive charge designer, confronted with a possible aerodynamic heating problem, might be as follows

- (a) Compute the maximum stagnation temperature to which a round might be exposed,
- (b) If possible without compromising other features of this design, choose an explosive which will survive this temperature,
- (c) If doubt remains regarding survival of aerodynamic heating, make a conservative estimate of the heating rate based either on a simplified model or experimental data for an analogous system, and
- (d) If doubt remains at this point, give serious consideration to the use of insulation or heat sinks.
- (e) Testing of the system may be required.

*c. Acceleration.* As vehicles, ammunition items must, of course, be accelerated. The magnitudes of the accelerations are in some cases immense. To the designer of explosive charges, accelerations are a source of structural loading which applies inherently to all masses including that of the explosive material. Accelerations associated with changes in the momentum along the line of flight are always variable, usually impulsive, while centrifugal accelerations of spin stabilized projectiles remain nearly steady during the time of flight.

When considering the effects of acceleration of ammunition, its variability must also be considered. On the one hand, it is often possible to reduce peaks by use of shock absorber principles. On the other, the rapid changes can result in impact forces of much greater magnitude than those due to the direct effects of gross acceleration. In considering these effects, the designer should obtain the best estimate available of the time-acceleration function to which his device will be subjected. Table 1 lists the magnitudes of some typical accelerations of ammunition.

## 5. Structural Aspects

*a. Neglecting the Strength of the Explosive.* To sustain accelerations and still retain their functional capability as explosive charges and mechanisms, ammunition must be designed with full recognition of its functions as a structure. The time-honored practice of neglecting the strength of the explosive material, that is, of designing the container to hold a liquid of the density of the explosive, can greatly simplify structural design and is generally quite conservative. It may not always result in the best design and, in some cases, it is inapplicable because

- (a) The strengths of all explosives are far from negligible and those of some materials are quite appreciable. The strengths of cast explosives are on the order of 2000 psi (compressive) and 200 psi (tensile). Those of plastic bonded explosives are somewhat higher.

TABLE 1. VALUES OF ACCELERATION IN AMMUNITION

<u>Ammunition and Condition of Exposure</u>	<u>Typical Peak Acceleration (g)</u>	<u>Direction</u>
Projectile setback when fired in gun	50,000	Axial
Projectile piercing armor	-150,000	Axial or Oblique
Rocket or missile, normal launch	100	Axial
Rocket or missile, gun launched	30,000	Axial
Missile steering	40	Transverse
Missile flight vibration	10	Random
Mine water entry	-2,500	Axial

Note: Forward acceleration is conventionally assigned a positive value.

(b) The resistance of the explosive material to plastic deformation can result in a load distribution on the container that is very different from that computed by assuming the explosive to behave as a liquid.

(c) In many applications, explosive performance could be improved by a smaller metal to explosive ratio from that dictated by design in which the strength of the explosive is neglected. Improvement may also result from a different spatial configuration in which the strength of the explosive is utilized.

(d) Some applications require metal so thin and soft as to have little value as a structural member.

(e) The resistance to deformation and eventual failure of an explosive material under stress could result in impact forces much higher than those calculated using the hydrostatic approximation.

For these reasons it is always best, and sometimes necessary, to design an explosive item as a composite structure or, at least, to consider the effects of its behavior as such.

*b. Consequences of Structural Failure of Explosive Charges.* Obviously, those charges whose output characteristics are closely associated with their geometrical configurations, such as shaped charges, will not function properly if the geometry is altered by structural failure. Other consequences of structural failure may be more serious when they occur. Although available evidence indicates that high mechanical stresses are, in themselves, incapable of initiating explosive reactions, movement under high stress, particularly the rather sudden movement resulting from a structural failure, provides a mechanism for the development of hot spots which may become reaction nuclei (see Paragraph 15). Where the failure results in the relative movement of two adjacent metal members with explosive in between, action similar to an impact or friction sensitivity test (where the explosives are pinched, ground, or impacted) may result in premature initiation.

The initiating trains of ammunition are generally composed of a series of rather small charges which communicate detonation only when properly spaced and accurately aligned. Hence, a structural failure can result in either premature functioning or complete failure.

*c. Structural Components as Sources of Fragments.* In many types of ammunition, notably artillery

fragmentation projectiles, the case serves two somewhat contradictory functions: that of the principal structural member and that of the source of fragments. In the one role it has to hold together under high gun acceleration and centrifugal stresses; in the other it must fly apart in a prescribed manner. The high strength which holds it together in the gun also absorbs a significant amount of the energy liberated when the explosive detonates. The choice of a structure and configuration conducive to optimum fragmentation may unduly weaken it. The charge-to-case weight ratio which is best for fragmentation may afford too little metal for structural stability. In addition, the aerodynamic considerations of stability and range are involved. The design of such a projectile is a compromise of internal, external and terminal ballistic considerations (discussed in Paragraphs 29-33). In other types of fragment-producing ammunition, where structural or aerodynamic considerations are less stringent, the designer has more freedom to adapt shape, construction, and material to obtain optimum fragmentation.

*d. Interaction of Structure with Explosive Materials.* In addition to the interaction of explosives and inert parts to form a composite structure and their interaction to produce output effects, important interactions between explosives and inerts are involved in initiation, growth and propagation of detonation. The pinching, grinding and impact resulting from the relative movement of inert components in contact with explosives are, of course, essential phases of the operation of stab and percussion initiators. The phenomena involved in such initiation processes are discussed in Paragraphs 20-23.

The importance of confinement in every phase of the initiation, growth and propagation of explosive reactions cannot be overstressed. A change in the confining medium can change the critical value of a dimension by a factor of ten or more. Various aspects of the effects of confinement upon explosive reactions are discussed in practically all of the chapters of this pamphlet.

Consideration of the role of an explosive material as a component of the structure and of its interaction with inert structural components from the conceptual stage onward will probably avoid some problems in the testing and evaluation stages.

## 6. Mechanical Aspects

*a. Functioning.* In the sense that their useful output is generally in the form of mechanical work, ex-

plosive charges are mechanical devices. However, the explosive charge designer must also consider those aspects of the mechanical functioning of ammunition which are involved in placing it in the desired location with respect to its target, safeguarding against operation until it gets there, and initiating the reaction at the desired place and time. Both the effects of these preliminary mechanical functions on the explosives and the effects of the presence of the explosives on the functioning must be considered. Because mechanical functioning generally occurs after the ammunition has been launched, the necessary energy must be either stored in or derived from the after-launch environment of the ammunition.

Forms of stored energy which have been used include elastic (cocked springs, compressed gases), chemical (batteries, propellants, explosives), magnetic (permanent magnets) and electrical (charged condensers, piezoelectric elements). Environmental sources include aerodynamic or hydrodynamic forces incidental to the motion of the ammunition through the ambient fluid; acceleration forces related to launching, spin, water entry, and target impact; hydrostatic forces due to changes in ambient pressure; magnetic forces related to movement with respect to the earth's field; electrical forces related to environmental potential differences (electrostatic in air and electrolytic in sea water), and thermal and radiation effects. Quite clearly, the range of forces represented is so great that exceptional precautions are necessary at the one extreme to retain nearly frictionless movement and, at the other, to protect the dormant mechanism, structure and explosive charges from damage.

*b. Location With Respect to Target.* The mechanical functions involved in placing the ammunition in the desired location with respect to its target might be considered as part of its functioning as a vehicle. However, those functions under consideration here are not so clearly vehicular functions as propulsion and flight of the item. They include such varied activities as separation of stages in multi-staged weapons, jump-up action of certain anti-personnel weapons and opening of parachutes. Some of these functions are accomplished by means of explosive actuators (Paragraphs 84, 85). Where such devices are used, it is a concern of the designers of other components to safeguard against their premature initiation or other damage. In other instances, where the source (such as movement of

a small bellows under the action of hydrostatic pressure) makes only a small quantity of energy available, precautions are necessary to prevent an increase in the frictional loading of the system resulting from the distortion of the weapon case, due either to dimensional instability of the explosive material or to differential thermal expansion.

*c. Safety and Arming Devices.* It is a basic requirement of fuze design that the arming action must result only from some force or condition uniquely associated with launching or after-launch environment. Where launching forces are used, arming must be delayed until a safe distance is attained between ammunition and the point of launching. These principles, combined with the wide variety of launching, propulsion, and stabilization means used, the range of after-launch environments, and the inventive ingenuity of fuze designers have resulted in a proliferation of arming devices and schemes.

The arming requirements have made necessary in some instances the use of forces which are so weak as to place very high standards on tolerances, finishes and balance of moving parts, some of which carry explosive components. The designer of explosive components for use in safety and arming mechanisms must be particularly careful to safeguard against dimensional instability, exudation and loss of explosive material. Any design change which results in a change in mass or in mass distribution should be considered carefully in the light of its effect upon the functioning of inertial arming systems, including rotors of fuzes for spin stabilized devices. The effect of changes in mass distribution caused by arming operations may sometimes require examination by an exterior ballisticians.

The design of a safety and arming mechanism is a three way compromise between reliability, quality control and compactness. If the components are large enough, they can be reliable even if they vary greatly from item to item, and quite safe if far enough apart in the unarmed state. To meet the increasing demand for miniaturization, it will be necessary to improve continually the standards of reproducibility of output and sensitivity of explosive components and the techniques for their evaluation. The designer of the mechanism must lean heavily on the explosive component designer because the basic dimensions of the mechanism depend upon the characteristics of the explosive components.

## 7. Electrical Aspects

*a. Environments.* The complexity of our electrical environment is staggering. Practically every insulator has a static charge. Any two dissimilar pieces of metal, wet with slightly impure water, make a battery of sorts. Weld them together and change their temperature and we have a thermal generator. Every spark plug, every switch, every thunderstorm, and all the stars keep broadcasting transients. Hence, all ammunition has, as does everything else, all sorts of small currents running through it at random at all times. In general, these currents remain so small as to have negligible heating effect. However, if the assemblage of conductors, semiconductors and dielectrics in the ammunition is exposed to radiation whose frequency corresponds to a resonant point, fairly high currents are possible. Electrostatic discharges and surges due to nearby strokes of lightning can also develop appreciable currents.

*b. Possible Initiation of the Main Bursting Charge.* If, at some point in a circuit, spurious currents are concentrated in a relatively small path in intimate contact with explosive material, it is not inconceivable that a hot spot might develop and form a reaction nucleus. Analysis of such systems is too complex to undertake. This is particularly true in view of the lack of evidence that such accidentally formed electric initiators have been the cause of accidents. It is well, however, to check a design for conditions which are obviously conducive to such effects.

*c. Electric Initiators Exposed to Spurious Signals.* A more frequent hazard is that of accidental initiation of electric initiators by static electricity, radio frequency pickup or induced surges. The system, where a shorted and grounded lead wire might serve as a tuned antenna for some frequency and a calked crack as a microwave leak, is extremely complex.

A series of thorough investigations has established that initiation by radio-frequency energy is a real hazard to electroexplosive devices. Several solutions have been proposed to alleviate this problem in the design stage. Those solutions dealing with the initiation of electric initiators are discussed in Paragraph 50. The designer of ammunition can minimize the hazard of initiation caused by the electrical environment by following these general design practices

(a) Use of initiators as insensitive as is compatible with reliability of the system.

(b) Taking the utmost advantage of the shielding properties of metal casings.

(c) Consideration of all possible roles of each component of a system as a circuit element.

(d) Incorporation of arming switches, out-of-line safety devices and similar devices to protect the system from premature initiation.

(e) Design of components which are as specific as possible in their input characteristics, including where applicable the special schemes discussed in Paragraph 56, and

(f) Arranging for tests, under the best simulation possible of service electrical environments, to determine the susceptibility of a system to electrical hazards.

## C. GENERAL DESIGN CONSIDERATIONS

### 8. Economics

The assessment of a weapons system involves the comparison of its value with its cost. The value per round may be considered to be the product of the military value of the damage of which a round of ammunition is capable and the probability that a given round will inflict this damage. The cost of a round of ammunition includes the cost of delivering it to its target as well as that of producing it.

Each of these quantities is, in itself, a complex combination of diverse factors which may include aspects of statistics, logistics, psychology, aerodynamics, ballistics, military strategy and tactics and all branches of engineering. Most organizations charged with the development of weapons systems include operations research or weapons systems analysis groups who feed combinations of experimental data, rigorously derived mathematical expressions and careful estimates into electronic computers to obtain estimates of the military values of various weapon systems. If a system is undergoing evaluation at the same time that an explosive charge is being designed for it, the explosive charge designer may find it comparatively simple to obtain information regarding the relative value of several design variants in exchange for data regarding the influence of these variants upon effectiveness, reliability or safety. More frequently, the phasing of the program leaves the explosive charge designer in the position of having to make these decisions himself.

The number of details which might affect the reliability of ordnance have proliferated to such an extent that an attempt to be sure of everything could lead to the employment of the whole population as inspectors and evaluators. There is a limit to the manpower which can be expended in making sure. In addition, the probable consequences of any type of failure are somewhere short of complete disaster. The refusal to accept any risk of failure or premature operation would lead to the certainty of being outclassed by almost any potential enemy.

Compromise is always necessary in decisions regarding the design, development, production, transportation, handling and use of ordnance. A two-way balance must be attained between the probability and consequences of failure and premature operation, and the costs of insuring against these events.

In attempting to arrive at such compromises, one's judgement is sometimes impaired by the feeling that saving a life or winning a war is more important than any amount of dollars. It must be borne in mind that the cost of one item represents a finite fraction of the nation's economic potential, that it limits the number which can be made available, and that lives and wars can be lost for the lack of ammunition as well as by its shortcomings with respect to safety and reliability. On the other hand, one well-publicized accident can destroy the usefulness of a weapon system or material by causing its rejection either at the command level or by troops on an individual basis.

## 9. Reliability

Reliability is a measure of the extent to which a device behaves as it was designed to behave during the usually short period between launching and completion of its mission. Obviously, reliability of ammunition and of its components is of key importance. Weapons are useless if they don't function as intended.

Reliability is defined in statistical terms. We say that a system has a reliability of say 99 percent and we make this statement with a confidence of say 95 percent. The problem for explosives is more severe for two reasons. First, they are a small part of a complex system. Since the probability that all of the components in a system will function is the product of the probabilities of the individual components, the functioning probability of explosives must be high, higher than that of the total system. This requirement calls for high reliability of ex-

plosives. Secondly explosives are one-shot devices which cannot be tested repeatedly. Special work-or-fail methods of analysis have been developed which are described in Paragraph 106.

The evaluation of materiel, including estimation of its reliability, is usually carried out by an organization, or at least a group, other than the design group. Difficulties between these groups can be resolved more readily if the designer of explosive devices is familiar with the techniques used by evaluators, uses similar techniques to assure himself that his designs are reliable, and designs devices and systems in which reliability is as nearly inherent as possible. A few general suggestions can be made for the designer

(a) Whenever possible, use standard components with established quality level and other reliability criteria at least as high as that required by the application.

(b) Wherever possible, particularly in more complex and expensive materiel, use redundant systems.

(c) Specify materials for which the properties of importance to your application are well known and reproducible. Keep in mind that the average value for a parameter may be less important for design purposes than the extreme values.

(d) As far as possible, design items in such a manner that defects which affect reliability can be detected by means of nondestructive tests or inspection.

## 10. Safety

Safety is a basic consideration throughout item life. We are concerned with the extent to which a device can possibly be made to operate prematurely by any accidental sequence of events which might occur at any time between the start of its fabrication and its approach to the target.

While safety is also defined statistically, the approach to safety is somewhat different from that applied to reliability. The keystone of this approach is the fail-safe principle. Essentially, this principle states that any sequence of events other than that to which a round is subjected in normal operation shall result in failure rather than detonation of the round. Compliance with the fail-safe principle is usually accomplished mechanically, and is the reason most ordnance devices must be considered as mechanisms.

In terms of added bulk, weight and complexity, which can be translated into terms of reliability,

effectiveness and logistics, safety is expensive. Hence, the problem of safety is a double one. The designer must be certain that his device is safe enough and yet impose the least impairment of functioning.

A number of policies, rules, and safety codes that apply to various types of materiel have been promulgated. In view of the variety of these codes, it is well for a designer to examine in advance the safety criteria that will be applicable to his design.

The preceding remarks on safety emphasized the protection against premature functioning of the initiation package. However, this is only one aspect of system safety. Another example of safety is that of protecting against direct initiation of main charge or booster by impulses incidental to handling, shipping, storage or launching, and accidents which may occur during these operations. The vulnerability of ammunition to initiation by accident or enemy fire can seriously restrict its tactical usefulness or greatly complicate problems of storage, handling, and transportation. System design can reduce this vulnerability by affording mechanical protection, support, and confinement. Hence, safety is not a separate problem but an integral part of explosive charge design.

#### 11. Standardization

The decision as to whether to adapt a system design to the use of a standardized component or to design a new component especially adapted to a system is often one of the most difficult a designer has to make. On the one hand, a new item has often been developed because, in the layout stage of design, it took less effort to sketch in something that fit the dimensions than to find out what was available. On the other hand, the hard and fast resolution to use only shelf items has resulted in systems which are appreciably inferior to the best

attainable with regard to safety, reliability, effectiveness, or compactness, and in the perpetuation of obsolete items.

As a general rule, the standard item must always be given first preference and must be considered carefully. An important reason in explosive charge design is the cost and time required to qualify new items (see Paragraphs 105-110).

MIL-STD 320 lists a standardized series of dimensions for newly developed detonators, primers and leads and for their components.

#### 12. Information Sources

Of the many available publications in both classified and unclassified literature, we selected a basic library for the explosive charge designer. These general references are compiled and annotated at the end of this paragraph.

It is an underlying assumption that the reader has some knowledge of military explosives. For this reason, details of explosive materials are not treated in this handbook. Such data are contained in References *b*, *g*, *h*, and *i*. References *g* and *h* contain the most up-to-date collection of the newer explosives. References *d* and *f* contain design data for specific explosive components. Standard dimensions for explosive components are listed in Reference *c* while Reference *e* treats the design of fuzes of which explosive components are an important part. Much information in an earlier handbook, Reference *a*, has been used in this handbook. The handbook is now out of print.

These general references are identified by a letter to make multiple referral easier. All other references are numbered and listed at the end of the chapter to which they pertain.

Other Engineering Design Handbooks contain information pertinent to explosive trains. For a list of current titles see inside back cover.

## GENERAL REFERENCES

- a. Report NOLR 1111, *Ordnance Explosive Train Designers' Handbook (U)*, U. S. Naval Ordnance Laboratory, April 1952 (Confidential).  
A handbook of research results, data, and tests, on explosives and explosive components. *Out of print.*
  - b. TM 9-1910, *Military Explosives*, Department of the Army, April 1955.  
A manual about the common military explosives, covering descriptions, properties, tests, and handling methods.
  - c. MIL-STD-320, *Terminology, Dimensions, and Materials of Explosive Components for Use in Fuzes*.  
A standard establishing terminology, external and internal dimensions, and preferred structural materials for explosive components. *Originally issued as MIL-STD-638.*
  - d. Gunther Cohn, *Army, Navy, and Air Force Fuze Catalog (U)*, The Franklin Institute, Report F-A2238 and Supplement F-A2238-1, November 1959 (AD-305 024 and AD-313 702) (Confidential).  
A compilation of military and technical data on all standard and developmental fuzes and fuze explosive components.
  - e. Engineering Design Handbook 210, Ammunition Series, *Fuzes, General and Mechanical*.  
A handbook for the designer of fuzes and fuze components, with particular emphasis on mechanical types.
  - f. *Electrical Initiator Handbook (U)*, 3rd Ed., The Franklin Institute, April 1960 (AD-319 980) (Confidential).  
Has performance characteristics of twenty-five electric initiators, with curves of input sensitivity and functioning time.
  - g. Engineering Design Handbook 177, Explosive Series, *Properties of Explosives of Military Interest, Section 1*.  
Listing the properties and characteristics of eighty-three explosive compounds and mixtures.
  - h. Engineering Design Handbook 178(C), Explosive Series, *Properties of Explosives of Military Interest (U), Section 2* (Confidential).  
Listing the properties and characteristics of twenty-seven explosive compounds and mixtures.
  - i. Engineering Design Handbook 106, *Elements of Armament Engineering, Part 1, Sources of Energy*.  
A handbook on fundamental facts about chemical energy including theory of explosive reactions and properties of explosives.
- 
- \* See inside back cover for handbook designation.

## EXPLOSIVE REACTIONS AND INITIATION

## A. THERMAL DECOMPOSITION AND BURNING

## 13. Thermal Decomposition

Explosives are substances or mixtures of substances which may be made to undergo a rapid chemical change, without an outside supply of oxygen, with the liberation of large quantities of energy generally accompanied by the evolution of hot gases. As metastable materials, they react at all temperatures above absolute zero. The rates of these reactions are direct functions of temperature. For explosives of practical interest, the decomposition rates at normal temperatures of storage, handling, and transportation, are negligibly small. As the temperature is increased a few hundred degrees, the rates of thermal decomposition attain significant levels. The self heating of the explosive by the heat evolved in this reaction tends to further raise the temperature and increase the reaction rate. Where such circumstances result in a runaway reaction, a thermal explosion may result.

Most explosive reactions, whether intentional or accidental, result from highly localized heating which initiates a self-propagating reaction.<sup>1,1\*</sup> In such a reaction the heat liberated by the reaction of the explosive at one point in a charge raises the temperature in adjacent material sufficiently to cause it to react at a similar rate. The modes and rates of such self-propagating reactions so profoundly affect the usable phenomena associated with the functioning of explosives, that these phenomena can hardly be considered except in terms of these modes and rates.

The reaction of a typical charge of solid explosive, rigorously considered in its ultimate detail, is so complex as to defy quantitative description. Fortunately, however, the typical situation is such that one or another aspect of the behavior of

the material is so dominant that other aspects may be dismissed as second order effects. Hence, although gradual thermal decomposition, deflagration and detonation are usually chemically similar processes, their physical causes and manifestations are so different that they may be understood best by considering them as distinct phenomena.

The three modes of explosive reaction, thermal decomposition, deflagration and detonation, are similar in that their rates are directly related to temperature, pressure, or both while the reactions themselves result in the increase of these quantities. It follows that any charge of explosive, if contained so as to prevent expansion or losses of matter or energy, will eventually explode. If the temperature is uniform throughout the charge, the explosive will be a pure thermal explosion where each element of volume experiences the same self-accelerating temperature rise. More usually, any variations in temperature will tend to exaggerate themselves so that the self-heating reaction will run away at the hottest point from which a deflagration, in turn self-accelerating, will propagate. The self-accelerating deflagration is characterized by a similarly accelerating rise in pressure, which is propagated through the unreacted explosive as a compression wave. If the charge is large enough, the wave may develop into a shock of sufficient amplitude to propagate as a detonation.

## 14. Reaction Kinetics

Perhaps the reaction of an explosive material can be understood best by trying to visualize an explosive molecule. Such a molecule is a structure containing atoms which have very strong affinities for one another, and which are prevented from responding to these affinities by their places in the structure. The positions of atoms within the structure of a molecule and that of molecules within the crystal are fixed, not by rigid links, but by equilibrium of electrostatic and quantum-mechanical

\* Numerical References are listed in the end of each chapter while lettered References are listed in Paragraph 12 (end of Chapter 1).



exchange forces. Unless the temperature is absolute zero, each atom vibrates about its equilibrium position with a random motion under the influence of the similar random motions of its neighbors. These random motions, which are characteristic of thermal phenomena, apply to the partition of energy between molecules and between atoms of each molecule.

Temperature is a quantity proportional to the average energy of molecular agitation. At any given absolute temperature  $T$ , the frequency with which any one atom attains an agitational energy  $H$  is given by the function  $A'Te^{-H/RT}$ , where  $R$  is the universal gas constant and  $A'$  is an inverse function of the restraints to motion of the particular atom. If the agitational energy  $H$  exceeds a value  $W$ , known as the activation energy, the atom may escape from its position in the molecule and be free to assume more congenial relationships. This uproar increases the agitation of neighboring molecules, that is to say, the reaction proceeds with the evolution of heat. The reaction rate  $k'$  is the frequency with which the agitational energy  $H$  of individual molecules exceeds  $W$ . Thus

$$k'(T) = A'Te^{-W/RT} \quad (4)$$

The classical Arrhenius equation sets  $A'T = A$  for small temperature ranges, and

$$k'(T) = Ae^{-W/RT} \quad (5)$$

has been used more commonly to represent the temperature dependence of chemical reactions. For the temperature range of most experiments the difference between Equations 4 and 5 is not distinguishable (Fig. 2).

The qualitative implications of the Arrhenius equation deserve the consideration of all who deal with explosives. Since  $W$  for military explosives has a value between 10,000 and 100,000, while  $R$  is approximately two (for units of  $^{\circ}\text{K}$ , calories and gram moles), a small percentage change in temperature results in an order of magnitude change in reaction rate. The sharply defined temperatures which many experimenters have associated with decomposition, ignition or explosion (see Table 2) are quite readily explained in terms of these equations and the relatively limited range of rates which may be measured by most experimental techniques. (The ignition temperatures shown in the table are computed while the explosion temperatures are experimental.)

The Arrhenius equation expresses a characteristic of explosives which has, perhaps, a greater

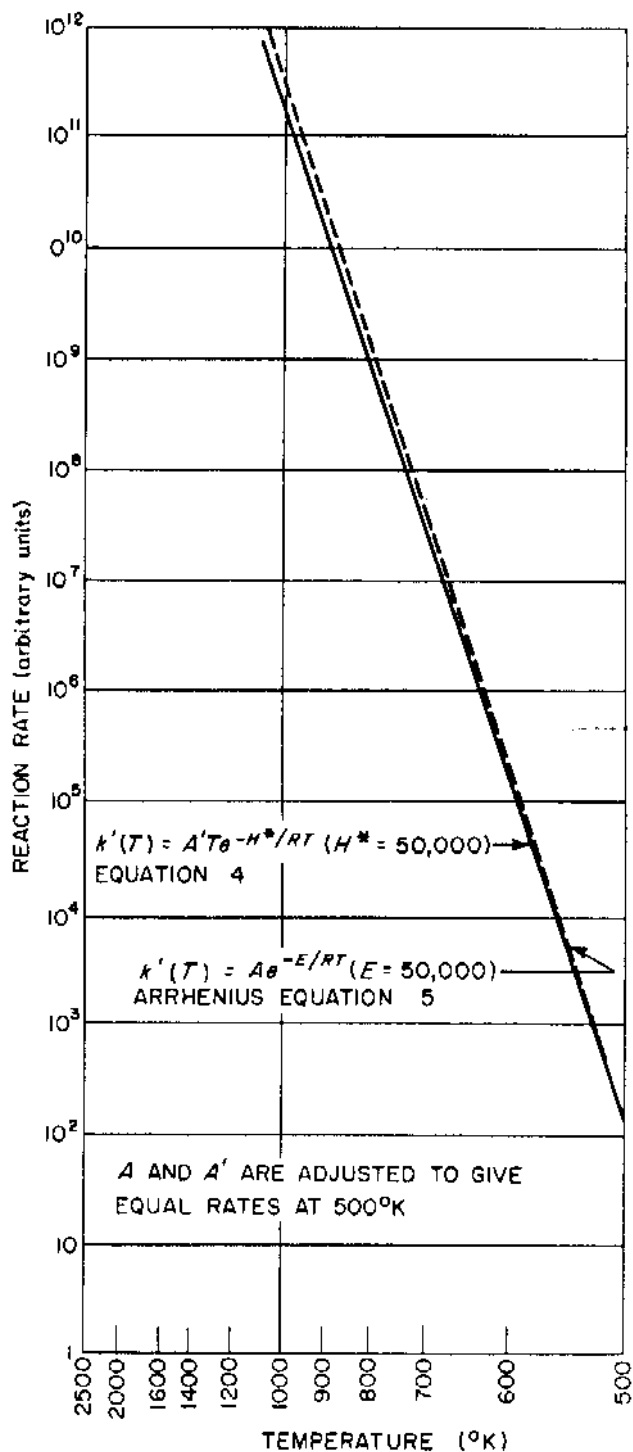

Figure 2. Computed Explosive Reaction Rates

influence upon the initiation process than any of their other attributes. For example, the reaction rate of a typical explosive with an activation energy of 50,000 calories per gram mole, at  $800^{\circ}\text{C}$  is more than ten times its reaction rate at  $700^{\circ}\text{C}$ .

TABLE 2. IGNITION AND EXPLOSION TEMPERATURES

Explosive	Thermal Ignition Temperature <sup>1</sup> (°C)	Explosion Temperature* (°C)				
		0.1 sec	1 sec	5 sec		
beta-HMX	—	380	—	327	Decomposes	306
Composition B	—	526	368	278	Decomposes	255
Cyclonite (RDX)	—	405	316	260	Decomposes	240
Haleite (EDNA)	—	265	216	189	Decomposes	178
Lead Azide	335	396	356	340	Explodes	> 335
Lead Styphnate	250	—	—	282	Explodes	276
Nitroglycerin (Liquid)	200	—	—	222	Explodes	—
Pentolite, 50/50	—	290	266	220	Decomposes	240
PETN (Pentaerythritol Tetranitrate)	215	272	244	225	Decomposes	211
Silver Azide	—	310	—	290	Explodes	—
Tetracene	160	—	—	160	—	—
Tetryl	—	340	314	257	Ignites	238
TNT (Trinitrotoluene)	—	570	520	475	Decomposes	465

The experimental determination of the constants of Equations 4 or 5 for various explosives is complicated by the effects of reaction products, phase changes and multiple reactions, as well as by the heat transfer considerations. The reactions of most of the commonly used explosives are either accelerated (autocatalysis) or retarded (auto-stabilization) by the presence of their reaction products.<sup>2</sup> Because of these difficulties, generally accepted reaction kinetics constants for explosives are not available. However, the exponential form of the Arrhenius equation fits most experimental data so well that many investigators have ignored the complicating influences and derived more or less empirical Arrhenius constants from plots of the logarithm of the rate, or of a rate-dependent quantity, as a function of the reciprocal temperature.

For the explosive charge designer, the most useful consequences of theoretical studies of thermal decomposition problems are the development of (a) a more valid basis for qualitative thinking, and (b) coordinate systems within which most experimental data form recognizable patterns. When confronted with an explosive charge design problem, a suggested approach to a realistic solution consists of the following two steps

(a) Obtain, either from available literature or specifically designed tests, experimental data for situations which simulate as closely as possible those to be encountered in service.

(b) Interpolate between data points using coordinates of inverse temperature, and logarithms of times, rates or dimensions. These coordinates may also be used for extrapolation. However, extreme care should be exercised when extrapolating because abrupt changes in the decomposition rate (such as those due to melting of a component of an explosive material) may occur outside of the range of experimental data.

## 15. The "Hot Spot" Theory of Initiation

The view that nonuniformity of heat distribution is essential to the usual initiation process has been called the "hot spot" theory of initiation. In explosive initiators, the energy available is concentrated by the use of small diameter firing pins and, in electrical devices by dissipating the energy in short and highly constricted paths. The addition of grit to primer mixes serves a similar function. Not only is nonuniformity of energy distribution essential to most initiation processes, but it is an important factor in the growth and propagation of practically all chemical explosive reactions used in ordnance.

Because of the exponential nature of the Arrhenius equation (Eq. 5), the reaction rate inevitably reaches a level such that heat is liberated faster than it can be lost. From this point on, the reaction is self-accelerating and quite rapidly becomes explosive.

Although a general equation which includes consideration of all of the complicating factors would be completely intractable, the use of simplified models makes possible solutions which contribute to the understanding of the initiation process. However, simplifications must be used cautiously. For example, it frequently appears that each explosive has a critical initiation temperature which is independent of dimensions. Although more extensive experiments or more detailed analyses have usually shown it to be an approximation which applies to only a specific class of initiator, this relationship can be a useful design tool if its limitations are kept in mind. Perhaps the most important implication of the foregoing is that, since in any type of system, the critical temperature varies so little with dimensional changes and since the volumetric specific heats of solids

vary only slightly from one to another, the minimum energy required to initiate an explosive device is nearly proportional to the volume of material which is heated by the input energy pulse. It must be stressed that this is an approximation which should be applied only to comparisons of performance within initiators of the same type initiated in a specific manner.

Since the energy available for the initiation of explosives in ordnance is usually limited, initiation systems are designed to concentrate this energy, as heat, in a relatively small volume. Obviously it it won't stay that way. The smaller the volume in which a quantity of heat is concentrated, the faster it is dispersed, other factors remaining similar. In order to concentrate a given amount of heat in a nucleus of a given volume, the heating must take place in a time which is short compared with the cooling time of the nucleus. If the rate at which energy is introduced, that is, the input power, is reduced to a low enough level, the losses will establish equilibrium with the sum of the input power and the heat generated by the reaction. An infinite quantity of energy will not cause initiation under such equilibrium conditions.

Up to this point, the present discussion has been concerned with the establishment of reaction nuclei. Once reaction is established at a nucleus, the useful functioning of an initiator requires that the reaction be propagated to the remainder of the explosive charge of the initiator, and thence, to the next component of the explosive system. Similarly, the consequences of accidental initiation depend upon such propagation. The same heat transfer mechanisms whereby heat is dissipated from a prospective reaction nucleus are necessary for the propagation of the reaction from an established nucleus. However, conditions which promote sensitivity to one or another stimulus will sometimes cause failure of propagation if carried to extremes. Heat may be transmitted by conduction, convection, radiation and what might be called thermodynamic heat transfer. All of these mechanisms are involved in the reaction of explosives, but their relative importance varies greatly, and changes as the reaction progresses.

The process referred to as thermodynamic heat transfer is one of the most important mechanisms involved in explosive reactions. The cooling of reaction products, due to adiabatic expansion can, under some circumstances, quench a reaction. Conversely, unreacted explosives can be heated by compression to reaction-inducing temperatures.

When the compression is of sufficient magnitude and suddenness to cause a significant increase in temperature, it is generally propagated through the material as a shock wave. Detonation, the ultimate goal of most explosive systems, is a type of reaction propagation which depends upon this mechanism to transfer the heat of reaction to the unreacted explosive.

## 16. Deflagration

The very rapid burning of which explosives are capable (by virtue of containing all of the elements needed for the completion of their reaction) is known as deflagration. Deflagration is distinguished from detonation by its subsonic propagation rate, from which it may be implied that shock waves are not important factors in the propagation. Deflagration of a gas may be described quantitatively in terms of thermodynamics and hydrodynamics. That of solid explosives is more complex and, for real situations, is subject to only qualitative description. Empirical relationships, which are quite reasonable consequences of the mechanisms indicated in the qualitative description, are quite useful in the prediction of the course of this type of reaction.

The reaction products of most solid explosives are largely gaseous. Most of the important aspects of the behavior of these materials are related to this phase change at the time of reaction. The surface burning rate is determined by the rate at which heat is transferred from the hot, gaseous reaction products to the unreacted solid explosive material. (The local reaction rate is quite probably related to temperature by the Arrhenius equation, but the very steep temperature gradient is reflected in a much steeper reaction-rate gradient, so that the reaction zone is almost vanishingly thin.) The rate at which heat is transferred between a gas and a solid is the product of the difference between their temperatures and a surface coefficient. The surface coefficient is a function of the flow conditions in the gas and its thermodynamic properties, and is directly proportional to pressure. When a solid explosive burns, temperature increase, flow conditions, and thermodynamic properties of its reaction products are nearly constant. Thus, the rate at which heat is transferred from the products to the explosive and, consequently, the surface burning rate should be directly proportional to the pressure. For some materials it is, but for most the situation is somewhat more complex.

The reaction of many, perhaps most, explosive compounds takes place in the gaseous phase. The rate of surface burning in such cases is essentially the rate at which the surface erodes due to sublimation. This in turn is proportional to the rate of heat transfer divided by the heat of sublimation. Since the heat of sublimation of the solid usually increases with increasing ambient pressure, the increase of the surface burning rate with increasing pressure is somewhat less than linear. A relationship between burning rate  $R$  and pressure  $P$  which has been found to apply to the surface burning of a number of solid explosives and propellants is

$$R = GP^n \quad (6)$$

where  $G$  is a constant and the exponent  $n$  is less than one. Surface irregularities may increase the burning rate by increasing the surface area and by introducing a component of flow parallel to the surface, thus increasing the surface coefficient of heat transfer. Table 3<sup>3</sup> lists constants of Equation 6 for various common military explosives.

TABLE 3. VALUES OF THE CONSTANT  $G$  IN EQUATION 6

Explosive	$G \times 10^3$
Ammonium Picrate	6.25
Tetryl	8.7
TNT	12.5
PETN	21
RDX	36

The pressure dependence of the rate of surface burning, and the fact that gas is evolved at a rate proportional to the surface burning rate, result in a situation where the confinement afforded by the case of an explosive charge is the most important factor in determining the course of the reaction. In a completely enclosed case, pressure continues to build up and burning rate continues to increase until the case bursts or the explosive is expended. The explosion which results is entirely due to the sudden release of gases when the case bursts. If the case has a leak, orifice or nozzle, conditions of equilibrium are possible in which the rate at which gases are evolved equals that at which they flow from the container.

For rockets, in which stability of this kind is extremely important, the effort is made to develop propellants for which the exponent  $n$  of Equation 6 is as low as possible. In initiating elements, the instability which results from the high values of  $n$  associated with porous explosives is an important factor in the rapid acceleration of reaction propagation, a part of the function of such elements.

## B. DETONATION

### 17. Transition from Deflagration to Detonation

*a. Transition Process.* The transition from deflagration to detonation is generally divided into three stages (a) deflagration, (b) low order detonation, and (c) high order detonation. The transition from one to the other of these stages is usually quite sudden and is greatly influenced by three factors, particle size of the material, porosity, and confinement provided by the environment.

The process of transition from the first stage can be described on the basis of the following concepts: The deflagration reaction rate accelerates rapidly if the particle size is of the right magnitude. When confined, this increased reaction rate results in increased pressure which propagates as a shock wave in the unreacted explosive. As the shock wave becomes of increasing strength, shock heating will cause a fast enough reaction to sustain the shock, which then propagates as a low order detonation. This low order detonation then propagates as a shock wave which, if reinforced by sufficient energy, will accelerate to produce a high order detonation.

Particle size influences the acceleration rate of the reaction as does particle porosity because of their effect on the surface area which is exposed to the hot gaseous reaction. Experimentation has shown that for each particle size there is a critical pressure at which the increase in burning rate with increasing pressure is faster than linear.<sup>1</sup> This critical pressure is inversely related to particle size.

*b. Growth of Detonation in Primary High Explosives.* In a series of experiments using the arrangement shown in Figure 3<sup>3</sup> containers were sectioned after firing and the expansion of the bore was taken as a measure of the vigor of detonation. The

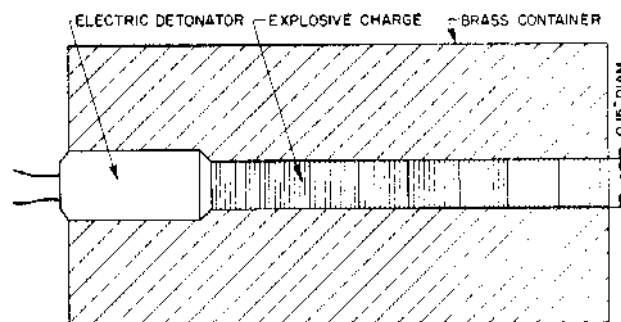

Figure 3. Arrangement Used in Observations of Detonation Growth

arrangement was also used to measure propagation velocities.

(1) *Lead Styphnate*. The growth of reaction in lead styphnate was very gradual in all cases. It grew fastest (as indicated by the taper of the bore) in material pressed at 4000 to 5000 psi. Under these conditions, the maximum measured propagation rate for the second inch of column was about 2000 meters per second, which may be compared with the stable rate of over 4000 meters per second for these loading conditions. The growth is apparently continuous, though slow and, in a few experiments, approached its maximum rate in several inches. Because of its low rate of growth to detonation, lead styphnate is not used as a detonating charge, but mainly as a flash charge, where its reproducible ignitibility is an advantage.

(2) *Lead Azide*. It has been frequently asserted that lead azide detonates immediately when ignited and that it cannot be "dead pressed." It is true that the growth of detonation in lead azide is so much more rapid, even when loaded at very high pressures, that experiments in which detonation growth and "dead pressing" can be observed in most other explosives would lead to this conclusion. However, these properties of lead azide, combined with the ever rising pressures for ruggedization and miniaturization, have resulted in the evolution of designs for which these assertions must be reexamined.

In experiments of the kind discussed in the foregoing paragraphs, lead azide (dextrinated) made the transition from burning to detonation quite suddenly for all combinations of loading pressure, confinement and initiation. However, when pressed to densities above 95% of maximum theoretical (requiring upwards of 100,000 psi loading pressure) and mildly initiated, it would detonate at rates of 1400-1700 meters per second compared with an approximate rate of 3000 meters per second obtained at lower densities.

*c. Growth of Detonation in Secondary High Explosives*. One of the principal features which distinguishes a secondary explosive from a primary

explosive is its much smaller propensity for completing the transition from burning to detonation. As in primary explosives, this transition is affected by the interaction of a number of factors including charge size, state of aggregation, confinement, and vigor of initiation. However, for any given combination, the transition is much slower and many charges, even main bursting charges, are so small as to be consumed by low order detonation before the transition can take place. Such main charges are, of course, much safer to handle and use than those in which the transition will take place. In addition to the assessment of hazards of main charge detonation after accidental ignition, the growth of detonation in secondary high explosives has been investigated by those who are interested in the development of safer detonators. The latter have made significant contributions in the determination of optimum conditions for the most rapid growth of detonation in some of the more sensitive secondary high explosives.

Experiments similar to that illustrated in Figure 3 have been carried out with columns of PETN, RDX and HMX.<sup>6</sup> A refinement was the use of coaxial ionization probes which could be led in through small radial holes at fairly frequent intervals along the length without unduly affecting the confinement. Velocity measurements obtained with these probes and oscilloscopes and timers established the correlation between bore deformation and propagation velocity. The lengths of columns required to grow to detonation, referred to as burning lengths were determined for a number of combinations of particle size and loading density. Hardly design data, these lengths may be taken as indications of development goals. For each explosive, optimum values were indicated for each of these variables at which the burning length reached a minimum value (see Table 4<sup>6</sup>).

In other experiments it has been established that the growth of detonation in a column of secondary explosive is accelerated by the insertion of a barrier followed by an air gap<sup>7</sup> (see Paragraph

TABLE 4. OPTIMUM LOADING DENSITIES AND PARTICLE SIZES FOR GROWTH OF DETONATION IN RDX, HMX AND PETN

Explosive	Optimum Loading Density		Optimum Particle Size		Burning Length (cm)
	Granulation Loading Density	Density (gm/cc)	Micron range	Approx. USS sieve cut	
RDX	Unsieved	1.29	251-124	60-120	1.2
HMX (first sample)	250-135 micron	1.26	251-124	60-120	1.9
HMX (second sample)	(Not determined)	—	76- 53	200-270	1.4
PETN	420 micron	1.59	124- 76	120-200	0.2

27) It might be expected that the explosive material, particle size, loading density, dimensions and confinement on both sides of the barrier-gap combination interact with the material and thickness of the barrier and the dimensions of the gap to determine the burning distance. A factorial experiment to determine the optimum combination would be a formidable program.

Growth of detonation has been observed in a number of cast explosives.<sup>8</sup> In Pentolite and DINA, high order detonation was established in ten to fifteen centimeters. In Composition B, the propagation rate grew to about 3000 meters per second, at which point the container apparently shattered, relieving the pressure and allowing the reaction to decay. In TNT, the reaction grew so little in twelve-inch columns that the containers were practically undamaged, and the propagation rates so low, 600 to 1000 meters per second, that it was difficult to obtain satisfactory records. By increasing the length to 34.5 inches and finally to 58.5 inches, it was possible to observe the growth of the propagation velocity to about 2000 meters per second. The increase was quite regular but seemed to be accelerating toward the end. The question as to whether the reaction would continue to accelerate, stabilize at a low order detonation, or burst the tube and die out has not yet been answered.

### 18. Shock Waves

Detonation is a mode of propagation of reaction in which the energy that initiates the reaction is transmitted to the unreacted material in the form of a shock wave. It has been referred to as a reactive shock. The following discussion of nonreactive shocks serves as a preface to that of detonation.

Shock waves, like acoustic waves, are a special class of compression-displacement waves. Although the behavior of such waves varies with their amplitude, their wave form, and the properties of the media in which they propagate, many relationships which derive from fundamental physical laws are the same for practically all cases. Although the typical wave attenuates as it propagates, this attenuation is so slow compared with the associated transitions that the wave may be assumed to be stable when examining its detailed structure. It is convenient, at the beginning, to assume an infinite plane wave in which only movements and changes along the axis of propagation are significant.

Consider, now, a wave propagating through a stationary medium. In a system moving with the

wave, the conservation of matter demands that the mass of material passing through each plane perpendicular to the axis be equal to that passing through each other such plane. In other words, the product of density and velocity is a constant at all points along the axis. In this system of coordinates, the undisturbed medium approaches the wave front at a velocity  $D$  equal in magnitude to that at which the wave propagates in the stationary medium. The velocity  $v$  of the material relative to the wave front is, of course, equal to the difference between the propagation velocity and the velocity  $u$  of the material at any point relative to the undisturbed medium. Thus, the equation of continuity has the form

$$\rho_0 D = \rho v = \rho(D - u) \quad (7)*$$

where  $\rho$  is the density and the subscript  $0$  refers to conditions in the undisturbed medium.

The impulse applied to the incremental mass  $dm$  which passes through the wave front in the differential time  $dt$  in each unit area is equal to  $(P - P_0)dt$  where  $P$  is pressure. By conservation of momentum, the momentum change  $udm$  is equal to this impulse. The incremental mass, of course, is equal to  $\rho_0 dx$ , where  $dx$  is the distance traversed by the shock wave in time  $dt$ . Thus

$$(P - P_0)dt = udm = \rho_0 u dx \quad (8)*$$

$$P - P_0 = \rho_0 u dx/dt = \rho_0 D u \quad (9)*$$

Equations 7 and 9 may be combined and rearranged to obtain

$$D = (\rho \Delta P / \rho_0 \Delta \rho)^{1/2} \quad (10)*$$

Equations 7 through 10 apply quite generally to all pressure-displacement waves for which the assumption of equilibrium is valid. The relationship between pressure, volume and temperature is known as the equation of state of a material.

\* In using Equations 7 through 10 in the estimation of shock conditions, two convenient systems of units may be derived from the CGS system. The use of grams as units of mass and centimeters as units of length results in densities in grams per cubic centimeter. These densities are numerically equal to the specific gravities of the materials which are given in most handbooks. The use of the second as the unit of time and the dyne as the unit of force results, for the usual shock or detonation calculations, in velocities (centimeters per second) and pressures (dynes per square centimeter) expressed in numbers so large as to elude intuitive grasp. Pressures expressed in bars (millions of dynes per square centimeter) and times in milliseconds can be combined with masses in grams and distances in centimeters to form a system in which these equations and other expressions of physical laws may be used without numerical coefficients. The system of grams, centimeters, microseconds, and megabars is also compatible and may be even more convenient.

Acoustic waves are those of such small amplitude that the volume change is negligible and  $\Delta P/\Delta\rho$  is more accurately expressed as  $dP/d\rho$ . Thus, the sound velocity  $c_0$  is expressed as

$$c_0 = \sqrt{dP/d\rho} \quad (11)$$

By combining Equation 11 with the ideal gas laws, the familiar equation for the velocity of sound in an ideal gas is found

$$c_0 = \sqrt{\gamma RT} \quad (12)$$

where  $\gamma$  is the ratio of the specific heat at constant pressure to that at constant volume, and  $R$  is the gas constant. For elastic solids and liquids the expression becomes

$$c = \sqrt{E/\rho} \quad (13)$$

where  $E$  is the elastic modulus appropriate to the material and mode of propagation.

Waves of finite amplitude (those in which the compression of the medium is sufficient to result in a significant change in the compressibility, that is,  $dP/d\rho$  changes significantly) may, if the pressure rise is continuous in time and space, be considered a succession of sound waves each moving in the medium compressed by its predecessor. The sound velocity may change as the medium is compressed, causing a distortion of the wave as it progresses. For example, in a gas, the temperature rise with compression causes the higher amplitude portion of the wave to propagate faster, outrunning the other portions until it reaches the front (see Fig. 4). The discontinuity of pressure density, particle velocity, and temperature which results is known as a shock. The equations of state of solids are more complex so that the modification of wave forms at pressures beyond their elastic limits varies from one material to another. Shock waves of certain amplitudes degenerate in some solids.<sup>9</sup> When compressed sufficiently, however, all matter becomes less compressible so that compression waves, if they are of sufficient amplitude, will develop into shock waves in any medium.

A curve, commonly known as the Hugoniot curve, may be used with Equations 7 through 10 to define the conditions behind the shock wave.<sup>10</sup> The Hugoniot curve is the locus of end points of shock compressions. The propagation velocity should never be computed from the slope of the Hugoniot curve but always from that of a chord connecting the initial point with the final point using Equation 10. For ideal gases, the equation of the Hugoniot curve is

$$\frac{P}{P_0} = \frac{\rho - \mu^2 \rho_0}{\rho_0 - \mu^2 \rho} \quad (14)$$

where  $\mu^2 = (\gamma - 1)/(\gamma + 1)$ .

Since the Hugoniot compression results in a larger temperature rise than does adiabatic compression, the gas becomes less compressible as the strength of the shock increases. It is thus apparent from Equation 10 that the velocity of a shock is a direct function of its strength. For situations where the density is so close to the limiting value ( $\rho_0/A$ ) that variations with pressure may be neglected, Equation 9 may be rearranged to give

$$P = \rho_0 D^2 (1 - A) \quad (15)$$

Using Equation 14 and the gas laws, the relationship may be expressed in terms of the Mach number  $M$  which is the ratio ( $D/c_0$ ) of the shock propagation velocity to sound velocity in the undisturbed medium

$$P/P_0 = M^2 (1 + \mu^2) - \mu^2 \quad (16)$$

All of the conditions behind the shock may thus be calculated for an ideal gas by combinations of Equations 7, 9 and 16.

## 19. Detonation Waves

*a. Equations of State.* Those concerned with ordnance have particular interest in the behavior of gases under two special sets of circumstances, (a) atmospheric air subjected to explosive shock, and (b) the reaction products of the detonation of military high explosives under conditions in the detonation head.

The rate of propagation of pressure displacement waves is proportional to the square root of the resistance of the medium of propagation to changes in density. This relationship, as it applies to various types of wave in various media, is expressed in Equations 10 through 13. Equations 12 and 13 for elastic waves are essentially ready to use. The constants for various materials are readily available in general scientific and engineering handbooks.

As the amplitudes of the waves increase and their forms change, the relationship becomes more complex. For shock conditions, the irreversible heating of the Hugoniot compression, Equation 14, describes relationship between pressure and density.

With the further increase in amplitude usually associated with the detonation of solid explosives, other factors add their influence to that of the Hugoniot heating to modify the pressure-density relationship further. These factors involve inter-

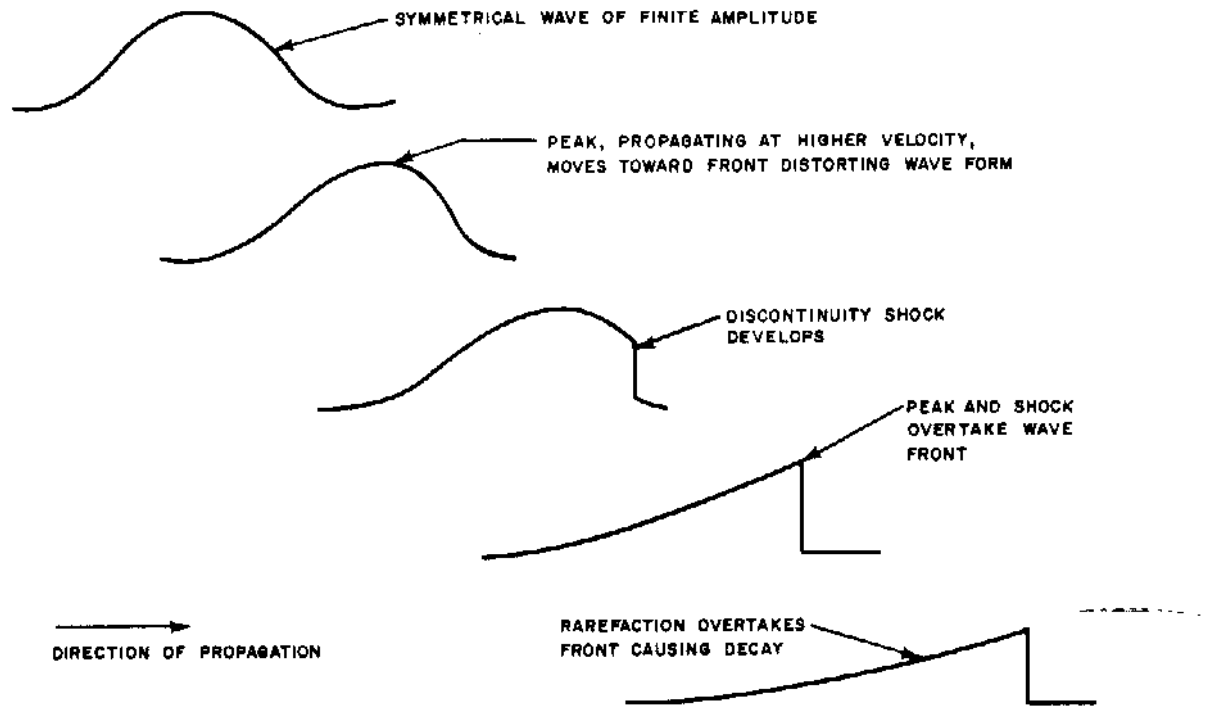

Figure 4. Formation and Incipient Decay of Shock Wave from Wave of Finite Amplitude

and intra-molecular and atomic forces, which derive from relatively simple electrostatic and quantum mechanical principles. However, they acquire a considerable degree of complexity by the time they have been combined to obtain the attraction and repulsion functions for a single species of atom. Hence, calculation of the behavior of strong shocks and the detonation of solid explosives is carried out using one or another of several empirical relationships.

Precise calculations of the thermodynamic behavior of atmospheric air under strong shock conditions have been made and presented in tabular form.<sup>11</sup>

For higher densities, the volume occupied by the molecules (or, more accurately, that in which the electrostatic repulsive forces are significant) is an appreciable fraction of the total volume available. If the molecules are assumed to be incompressible solids, the ideal gas equation of state

$$PV = RT \quad (17)$$

becomes

$$P(V - \alpha) = RT \quad (18)$$

where  $\alpha$  is the covolume of the gas, the volume occupied by the molecules.

The equations of state which have been applied to the computation of detonation conditions in

solid explosives are variants of Equation 18 in which account is taken of the compressibility of molecules and, in some cases, of their thermal expansion.<sup>2</sup> However, none of the equations proposed are adapted to simple, direct calculation.

For the early stages of expansion, which are of interest in connection with most military applications, the pressure-volume relationship

$$PV^n = K \quad (19)$$

where  $n$  and  $K$  are constants, is as accurate an approximation as any. The exact value of  $n$  depends upon composition and loading density of the explosive. For high performance military explosives, the average value is close to three.

*b. Chapman-Jouguet Conditions for Ideal Detonation.* The thermohydrodynamic theory of Chapman and Jouguet is concerned with the transition, insofar as it affects the propagation of detonation (the Chapman-Jouguet point), between conditions in the unreacted explosive and those at the completion of the reaction.

Of the various conditions associated with the detonation of an explosive, the rate of propagation  $D$  is the most easily measured. Many precise experimental data are available relating detonation velocity to density. In general, for military explo-



sives, the relationship is quite accurately represented by the equation

$$D = F + G\rho_0 \quad (20)$$

where  $F$  and  $G$  are constants characteristic of the explosive. Table 5<sup>2</sup> gives the constants of Equation 20 for a number of commonly used military explosives.

Data of this sort, relating detonation velocity to density, have been used to determine equation-of-state constants for the reaction products of detonation reactions. These constants, in turn, have been used with appropriate equations of state in the computation of the Chapman-Jouguet conditions for many explosives. More recently, techniques have been developed whereby the movements of metal plates in contact with explosive charges can be measured precisely and reduced to pressure-time data for detonation. In Table 6<sup>12</sup>, calculated values of parameters of the Chapman-Jouguet condition are given for various explosives. Experimental data, where available, are included for comparison. For organic high explosive compounds, the particle velocity is nearly one-fourth of the detonation velocity. Thus Equation 9 becomes approximately

$$P = \rho_0 D^2/4 \quad (21)$$

Note that in Table 6 the pressures computed empirically using Equation 21 agree with measured values nearly as well as those using the more rigorous theory, certainly well enough for most design purposes.

*c. Actual Detonation.* The previous discussion of detonation has been concerned with a one-dimensional model. In such a model, the conservation laws assume the simple forms of Equations 7, 9 and 10. Combined with data regarding the energy of reaction and equation of state, these laws completely define the conditions of detonation in

TABLE 5. DETONATION VELOCITY CONSTANTS FOR EQUATION 20

Explosive	$F$ (cm/ $\mu$ sec) $G$	
	$F$	$G$
Amatol, 50/50	0.095	0.415
Cyclonite (RDX)	0.249	—
Explosive D (Ammonium Picrate)	0.155	0.344
Haleite (EDNA)	0.203	0.328
Lead Azide	0.286	0.056
Nitroguanidine	0.144	0.402
Pentolite, 50/50	0.238	0.310
PETN (Pentaerythritol Tetranitrate)	0.160	0.395
Picric Acid	0.221	0.305
Tetryl	0.237	0.325
Tetrytol, 65/35	0.186	0.340
TNT (Trinitrotoluene)	0.178	0.323

this one-dimensional model, which is also described as an infinite plane wave and as an ideal detonation. Real charges, of course, have three finite dimensions. It might be questioned whether consideration of the infinite plane wave has practical significance. In fact, ideal detonation is closely approximated when the dimensions of a charge and the radius of curvature of the detonation front are large when compared with the reaction zone length (a situation which is not unusual inasmuch as reaction zone lengths of many explosives have been estimated to be of the order of millimeters or even less). Nearly ideal and definitely nonideal detonation are both quite common in ordnance performance.

Detonation may be termed nonideal when the radial flow of energy and material is sufficient to affect significantly the conditions at the Chapman-Jouguet point. As a result of the interdependence of these conditions with the velocity of propagation, such effects are manifest in velocity variations. Either convergent or divergent flow results in nonideal detonation. Convergent detonation is rare except in cases where it is induced by specialized designs. Divergence, however, occurs at most interfaces with inert materials. The most common shape of charges used for experimental observations of detonation is a long cylinder. In such charges, the effects of radial losses of energy and material become apparent as the diameter is reduced. For this reason such effects

TABLE 6. DETONATION CONDITIONS, CALCULATED AND MEASURED

Explosive	Loading Density $\rho_0$ (gm/cc)	Detonation Velocity $D$ (cm/ $\mu$ sec)		C-J Pressure $P$ (megabar)		Particle Velocity (cm/ $\mu$ sec)	
		Calculated	Measured	Calculated	Measured	Calculated	Measured
Composition B	1.712	—	0.802	0.275*	0.293	—	—
Cyclonite (RDX)	1.762	—	0.862	0.327*	0.325	—	—
Cyclonite (RDX)	1.80	0.875	—	0.349	0.348*	0.224	0.216
Cyclotol, 75/25	1.743	—	0.825	0.297*	0.313	—	—
Cyclotol, 78/22	1.755	0.829	—	0.311	0.213	0.213	0.218
TNT	1.64	0.695	0.695	0.2066	0.177	0.178	0.155
TNT	1.58	—	0.688	0.190*	0.177	—	0.163
TNT	0.624	—	0.380	0.026	—	0.11	—

\*From Equation 21.

have come to be known as diameter effects. Observable diameter effects include reduction of the detonation velocity and failure of detonation.

A rigorous quantitative theory which takes into account all of the complicating factors would be quite useless. It would be too cumbersome for a reasonable computer program even if sufficient experimental data were available to establish values for the many physical constants and properties involved.

Many theories and models have been based on a group of assumptions regarding the controlling mechanisms and processes.<sup>12-14</sup> Each of the theories is an attempt to derive a quantitative description of actual detonation from a consideration of a manageable number of the aspects of the process. Still, the solutions remain complex.

Even though a general theory is lacking, it is possible to make qualitative predictions of the behavior of actual detonations on the basis of the following generalities

(a) Other factors remaining constant, charges of small cross section detonate at lower velocities than those of larger cross section.

(b) The formula

$$D/D_i = 1 - K/r \quad (22)$$

where  $D$  is the detonation velocity of a column of radius  $r$  and  $D_i$  is the ideal detonation velocity may be used to interpolate or extrapolate detonation velocity data in the range where  $D/D_i = 0.95$  or more.

(c) If the diameter of a charge is too small, detonation will fail to propagate. Failure diameters for common explosives are listed in Tables 38 and 39.

(d) The properties of surrounding media can substantially alter diameter effects. For example, failure of detonation in TNT has been observed at diameters of the order of one inch for bar charges<sup>13</sup> while detonation at nearly ideal velocity has been observed for charges one-tenth this size when confined in steel or brass.<sup>14</sup> As might be expected from Equation 9, the shock impedance  $\rho_0 D u$  is a good criterion for the effectiveness of the confining medium.

(e) Velocities of nonideal detonations are affected by particle size of the explosive. Critical diameters and detonation velocity losses are reduced for fine particle sizes. For some materials in certain ranges, it appears that the ratio of charge dimension to average particle dimension is more significant than either absolute dimension. In cast

explosives, techniques conducive to fine crystallization reduce diameter effects.

(f) Particle size distribution is also a factor in diameter effects. Detonation velocities are higher and failure diameters smaller for uniform particle sizes than for mixtures of particle sizes.

(g) The velocity of propagation of actual detonation is determined by Chapman-Jouguet conditions at the center of the charge. Thus, it is possible, under some circumstances, for a material to detonate at near ideal velocity yet for material in the outer streamlines to react only partially.

(h) Nonideal detonation does not necessarily imply incomplete reaction. Many valuable military items include explosive charges which detonate at very low velocities compared with the ideal velocity for the explosives used.

(i) The relationship between density and nonideal detonation is complex. Observable phenomena can be explained and predicted on the basis that, with increasing porosity, the decreasing homogeneity of density is reflected in decreasing homogeneity of temperature distribution and consequently increasing initial reaction rate, while the decrease in pressure results in slower propagation of the grain burning reaction and consequently longer reaction zones. Thus, increasing porosity results in greater diameter effects upon detonation velocity but sometimes in smaller failure diameters, particularly under intermediate conditions of confinement.

## C. INITIATION

### 20. Establishing a Self Propagating Reaction

The rate at which the energy of an externally applied stimulus is transformed into heat and the degree of concentration of the heat in the explosive are as important in determining the magnitude of the stimulus necessary to initiate a reaction as are the chemical and thermal properties of the explosive. These latter factors are determined by the interaction of various physical properties of the explosive with quantities associated with the system or medium whereby the stimulus is transmitted to the explosive. For this reason, even though initiation may be thermal in the last analysis, sensitivity must be considered in terms of the nature of the initiating stimulus as well as its magnitude.

Two limiting threshold conditions for initiating apply to almost every system: that in which the energy is delivered in a time so short that the losses

are negligible during this time, and that in which the power is just sufficient to eventually cause initiation. In the first condition, the energy required is at its minimum while in the second, the power is at its minimum. These two conditions are represented by the dashed asymptotes in Figure 5. The relation between the energy required for initiation and the rate at which it is applied may be represented by the hyperbolas. In its general terms, the relationship illustrated applies to almost all initiators.

Initiation occurs when the rate at which heat is evolved in a reactive nucleus exceeds that at which it is dissipated. The impedance afforded by the surroundings to this dissipation is commonly referred to as confinement. Both experiment and theory demonstrate the dominant role played by confinement in the initiation, growth, and propagation of explosive reactions, particularly when the dimensions are as small as those of explosive train components.

The properties of a container which contribute most to confinement depend upon which of the several dissipative mechanisms is most important. This, in turn, depends upon which phase of the initiation process is most critical in a system.

In the early, self-heating stage of reaction growth, thermal conduction is the dominant heat transfer mechanism. In general, the containers of explosive charges are much better conductors than the explosives themselves so that a thin outer layer of explosive is a better insulation than the container. At this stage, except in rare instances, the properties of the container have negligible effect upon the initiation process.

The pressure of detonation of solid explosives is sufficient to burst or permanently deform any container which can be made. However, the time involved in detonation processes is of the same order of magnitude as the expansion times of the containers. The rate at which the container expands

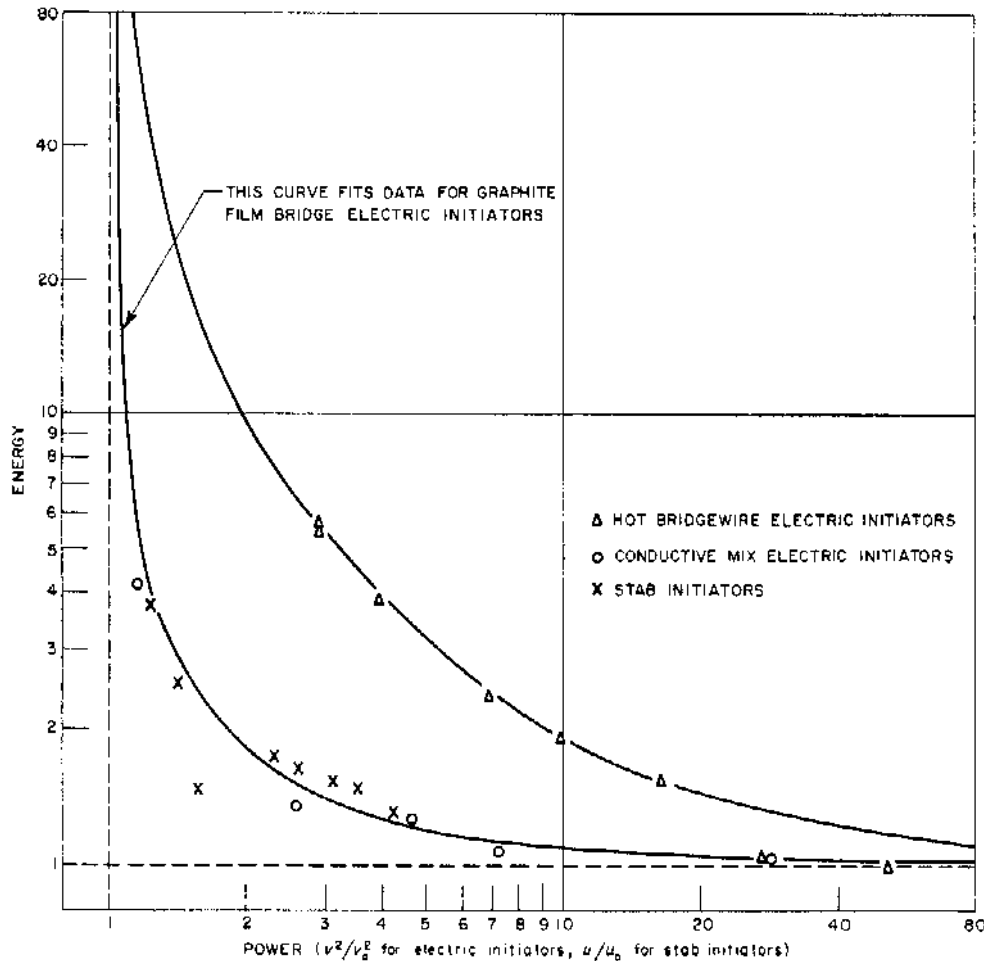

Figure 5. Energy-Power Relationship for Various Initiators

is determined by momentum considerations and is inversely related to the mass of container material which is moved. For a thin walled container this mass is essentially that of the wall; for a thick walled container, since only the material which has been reached by the shock wave induced by the detonation is affected, the affected mass is proportional to the density of the material times the shock velocity in the material. This product, known as the *shock acoustic impedance*, is a good measure of the effectiveness of a material as a confining medium for stable detonation.<sup>13</sup>

Initiation is complicated by such a variety of factors that the most carefully designed experiments yield data which are difficult to interpret in general terms. Practical situations are usually even more complicated. The questions which arise concerning initiation or explosion are best answered in terms of direct experiments with military materiel under service conditions or experiments with models and conditions which simulate service items and situations as closely as possible. For specific applications to initiator design, see Paragraphs 47-50 and for testing, Paragraph 108.

## 21. Initiation by Heat

*a. Hot Wire Electric Initiators.* Hot bridgewire electric initiators are the simplest and most direct illustrations of initiation by heat. Since a bridgewire can be measured, its volume, heat capacity and resistance can be calculated. Since it is further possible to generate electrical pulses and currents of accurately known characteristics, these can be combined with the bridgewire characteristics to obtain accurate estimates of power, energy, and temperature.

A large number of experiments have been carried out in which the interrelationships of the variables which affect the operation of bridgewire initiators have been investigated.<sup>14,15</sup> These investigations have verified the following principles

(a) The energy required to fire a hot wire electric initiator is roughly proportional to the volume of the bridgewire, if the energy is delivered in a short enough time (see Fig. 6<sup>a</sup>).

(b) Closer analysis shows that the threshold temperature increases with reduced wire diameter. This trend is less marked when the explosive has a high activation energy (like lead styphnate).

(c) The energy required per unit volume also increases somewhat with decreasing bridgewire length. End losses probably account for this.

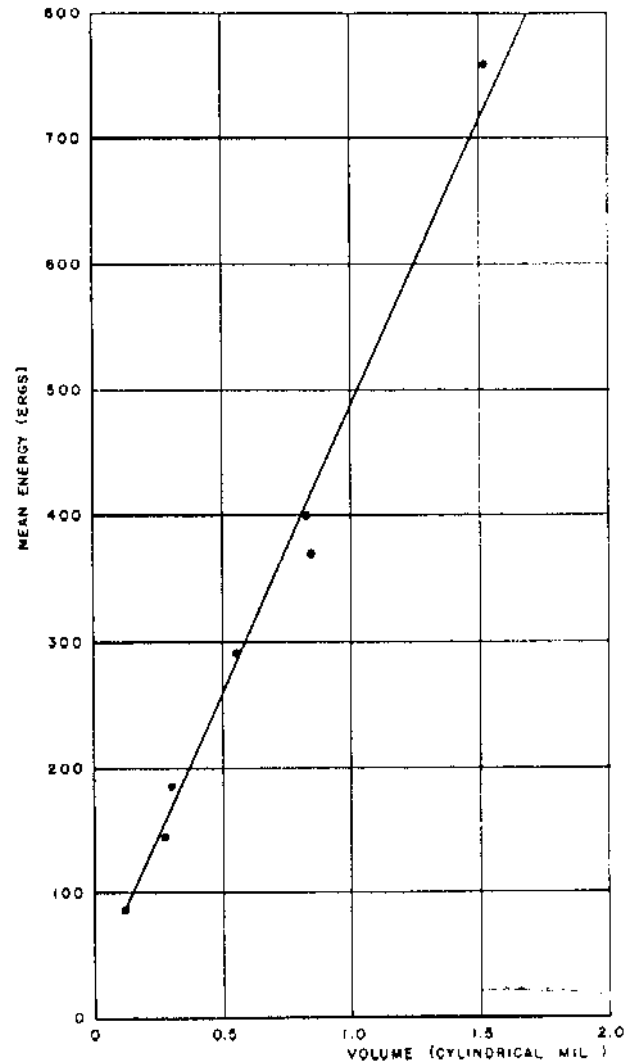

Figure 6. Typical Effect of Bridgewire Volume on Input Characteristics

(d) For a specific initiator design the energy requirement approaches a minimum as voltage, current or power is increased and increases indefinitely as power is reduced to a minimum.

(e) The relationship stated in (d) above refers to the average power of a firing pulse. Pulse shape has a secondary effect which is not easily measured.

(f) The current requirement varies approximately as the  $3/2$  power of the wire diameter and inversely as the resistivity of the bridgewire metal.

The behavior of hot wire electric initiators has been described by an equation which agrees well with experimental data

$$C_p dT/dt + \gamma T = I^2 R \quad (23)$$

where  $T$  is the temperature of a thermal mass  $C_p$  including the bridgewire and a surrounding layer of

explosive,  $I$  is the current through the wire,  $R$  is its resistance, and  $\gamma$  is a cooling rate coefficient.

Although the assumption of a constant ignition temperature yields remarkably accurate predictions of the behavior of specific hot wire initiators, it is an approximation. The generality mentioned as (b) above is evidence of the limitations of this approximation. The above equation and others are based on the assumption of a homogeneous solid charge of explosive. As applied to hot wire initiators, the equations also imply essentially perfect thermal contact between bridgewire and explosive. It has been shown that the separation between the bridgewire and explosive, which results from some combinations of mechanical design, loading procedure, and aging, can be sufficient to cause failure of hot wire initiators.

Another example of a discrepancy between calculations and experiment is worth noting. Based on the usual assumptions, the critical conditions for initiating secondary explosives, such as PETN or RDX, have been computed but attempts to achieve reliable high order detonation in these materials with hot wires have been negative.<sup>7</sup>

The initiation of explosives by means of electrically heated wires is at present more subject to precise quantitative control and theoretical prediction than any other initiation mechanism utilized in ordnance. The broad range of available bridgewire materials and sizes makes it possible to vary the energy sensitivity by a factor of nearly 100 without changing either the explosive materials or the external configuration. At the same time, the process is affected by a wide variety of other variables including electrical circuit parameters, state of aggregation of the explosive, and mechanical design of the initiator. For these reasons, a reasonably complete characterization of the hot wire sensitivity of an explosive would have to be in terms of a series of performance curves. Such data are available for only a few materials. Table 7 lists hot wire sensitivities of a number of primary explosives obtained for particular conditions. Extrapolations of these data to other conditions is a reasonable basis for an experimental development program but should not be used to make firm design decisions.

The application of the foregoing to the design of hot bridgewire electric initiators is discussed in Paragraph 50.

*b. Conductive Film Electric Initiators.* Both metallic and semiconductor films have been used as

bridges in electric initiators. The general principles discussed above for wire bridges also apply to metallic film bridges. In one system, the large ratio of surface to cross-section area of a film is used to greatly increase the steady state power requirement while retaining a desired resistance and energy sensitivity.<sup>7</sup>

TABLE 7. SENSITIVITY OF VARIOUS EXPLOSIVES IN WIRE BRIDGE INITIATORS

Explosive	Energy (erg)	
	0.0001 inch diameter	0.00029 inch diameter
DDNP/KClO <sub>3</sub> , 75/25	260	1050
Lead Azide	340	1340
Basic Lead Styphnate	125	700
LDNR	138	930
Tetracene	115	460

Tungsten wire 0.030 inch long fired at 14-20 volts

In semiconductive films, the negative resistance coefficients typical of such materials can produce a channeling of the current in a restricted path between the electrodes and therefore can result in extremely localized heating. This effect can be used to produce extremely sensitive initiators when such items are desired.

Semiconductive bridges used in ordnance are made of graphite. These bridges normally break down forming a very hot, localized arc when their voltage threshold is exceeded. Because of this behavior, it is difficult to design the bridges for specific conditions. However, the sensitivity levels can be determined experimentally with comparative ease.

Present graphite bridge initiators have essentially similar firing characteristics. Their resistance is on the order of 1000 to 10,000 ohms. The design and fabrication of film bridge initiators is discussed in Paragraphs 50 and 56.

*c. Conductive Explosive Mix Electric Initiators.* The usual conductive mix consists of an explosive to which is added a relatively small percentage of conductive powder. Such mixes are loaded so as to contact a pair of electrodes. Current flowing between the electrodes flows from one conductive particle to another through a series of contact points. In general, many such paths form a complex parallel-series network but one such path usually has a lower resistance than others so that the current tends to concentrate. Where the conductor has a negative resistivity coefficient, like carbon, the resistive heating tends to reduce the resistance of the preferred path and further concentrate the current. Even where the conductor is a metal, the

tendency for contact resistance to decrease with current flow results in a similar concentration in the preferred path. Along the path, the heat tends to concentrate at the contact points. The degree of concentration, and consequently the relationship between temperature and electrical input, is determined by a statistical interaction of particle size, uniformity of mixture, particle shape, composition, loading density and electrode configuration and spacing.

The formulation of a logical process for the design of a conductive mix system of specified electrical and firing characteristics is a task of such formidable proportions that it has not been undertaken. However, remarkable results have been attained by enlightened cut-and-try procedures.<sup>7,15</sup> The design and fabrication of conductive mix initiators is discussed in Paragraph 50.

*d. Transmission of Hot Gas.* The initiation of reactions of solids by means of hot gases depends upon a highly complex heat transfer situation. The heat transfer between a gas and a solid is proportional to pressure and temperature of the gas but is

also affected greatly by the movement of the gas relative to the surface and by surface porosity, roughness and configuration. Since the heat conductivity of the solid is almost invariably much greater than that of the gas, the temperature attained by the surface is much lower than that of the body of the gas unless the duration of exposure is sufficient for the solid to reach the gas temperature. In most situations encountered in military materiel, the total heat capacity of the gas is so much less than that of surrounding solids that the equilibrium temperature approached by the gas-solid system is practically the initial temperature of the solids.

Initiation by hot gases has not been computed but has been measured in a number of experimental apparatus.<sup>16</sup> A shock tube is an interesting tool for the exposure of explosives to high temperature gases. It has the advantage over other devices in that pressure and temperature of the gas in contact with the explosive change virtually instantaneously from initial conditions to those of the reflected shock wave. The shock pressures used in such experiments are too low for the shock waves transmitted into the explosive to be significant factors in

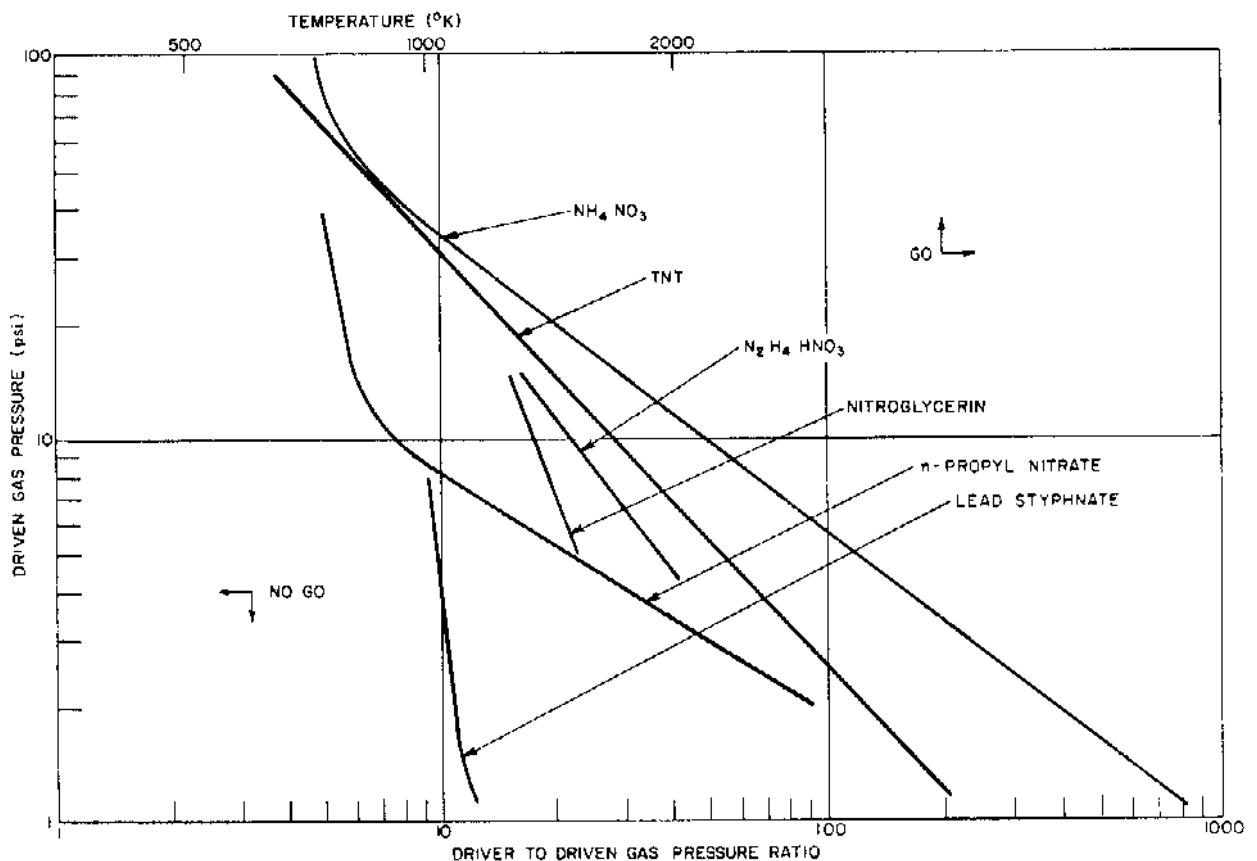

Figure 7. Threshold Conditions for Initiation of Various Explosives in a Shock Tube

initiation. Shock pressure, of course, is an important factor in the heat transfer between the gas and the solid explosive material. Some of the data for threshold conditions of initiation are shown in Figure 7.<sup>17</sup> The effects of variations in the gas composition are apparently quite significant but require further interpretation.

*e. Transmission of Hot Particles.* There is reason to believe that the most effective part of the output of some primers is the spray of hot, high velocity, solid particles or of droplets of liquid which they emit. Quantitative measurements of factors affecting initiation by such means are difficult to make. The process, however, is essentially the same as that of initiation of suddenly heated bridgewires, discussed in the beginning of this paragraph.

## 22. Initiation by Impact

*a. Impact Sensitivity Measured with Laboratory Machines.* Impact initiation of explosives is of interest to designers of ordnance for the assessment and elimination of hazards and for the design of stab and percussion initiators. For the assessment of the relative hazards during handling and use of explosives, several standard impact machines have been devised. Machines and test methods are described in Paragraphs 107 and 108. Essentially, an impact machine consists of an apparatus by means of which a weight can be dropped from various predetermined heights so as to strike an explosive sample. The height from which the explosive is initiated is a measure of impact sensitivity. Impact sensitivity values of common military explosives are shown in Table 20.

It has long been agreed that impact initiation is usually thermal.<sup>1</sup> The explosive is heated locally by compression of interstitial gases, intercrystalline friction, and viscous flow. On this basis it is possible to compute the reaction rates which may be expected in an impact machine. The data of one experiment are shown in Figure 8.<sup>18</sup> Here the temperature calculated for explosion in 250 microseconds is compared with impact sensitivity.

While impact sensitivity data are used as the basis for establishing safe practices and for selecting explosives which may be used in one or another application, there are two problems. First, it is admitted by most investigators that these tests really do not simulate any situation likely to occur in manufacture or use of ordnance. Secondly, different machines rank the same explosives in different orders. Perhaps part of the problem is that

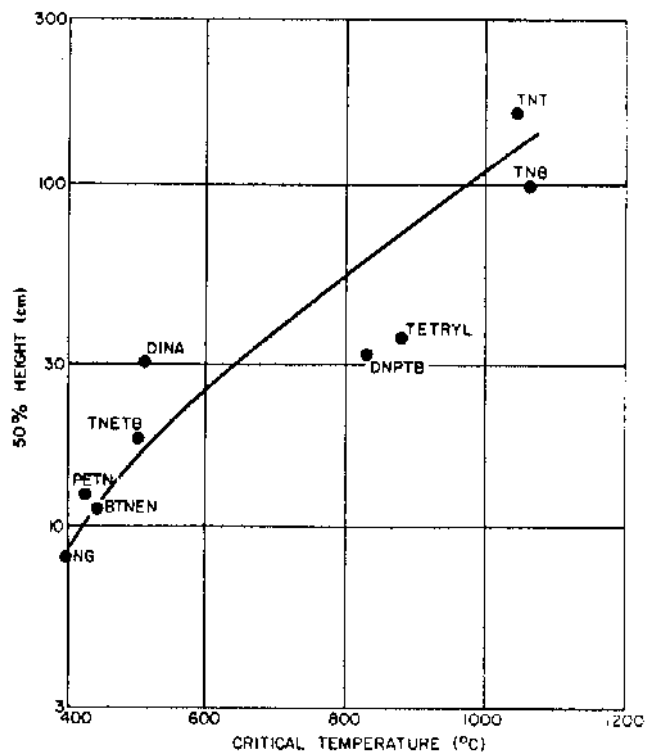

Figure 8. Input Sensitivity vs. Explosion Temperature

the explosive samples are not prepared in the same manner as cast or pressed explosive components. As a result, many have come to doubt the validity of impact test results as a basis for any binding decisions. Doubtlessly, sound and valid explanations can be found for the inversions in Table 20. However, such explanations are not particularly helpful in efforts to employ the impact machines in the selection of explosives.

Still, impact test sensitivities are in widespread use. If a newcomer to the field of explosives wonders what to make of this, he is in the company of experts of long experience. One basis which has been suggested for the assessment of the relative hazards connected with the use of an explosive is comparison by means of a variety of machines. Another is the design of tests more subject to analysis in physical terms. A third approach is the use of tests, such as those described in Paragraphs 107 to 110, which are designed to simulate specific conditions of service and use.

*b. Stab Initiation.* For detonators initiated by stab action, one of the most important functions is that of converting another form of energy into highly concentrated heat. As in electrical devices, the energy necessary is nearly proportional to the amount of material which is heated.

The standard firing pin for stab initiators is a truncated cone (Fig. 9). A rather interesting relationship has been found to exist between the sensitivity of the explosive used and the optimum size of the flat on the firing pin. The less sensitive the explosive, the larger the optimum diameter of the flat. This can be related to the compactness of the affected volume of the explosive. The most compact shape for a cylinder (that is, the shape having the least surface area for a given volume) is one whose length is equal to its diameter. Thus, as the energy required for initiation is increased, it is advantageous to distribute it over a large enough area to limit the effective length to nearly the diameter. The flat diameter given serves the priming mixes commonly used. Both steel and aluminum alloys are in common use. Aluminum results in a significant but not serious decrease in sensitivity.<sup>8</sup> Alignment is critical because misalignment will decrease sensitivity.

In general, the higher the density of the explosive, the more sensitive the stab initiator (see Table 8<sup>9</sup>). Because the denser explosive offers more resistance to the penetration of the firing pin, the kinetic energy of the moving mass is dissipated over a shorter distance, so that a smaller quantity of explosive is heated to a higher temperature.

TABLE 8. EFFECT OF LOADING PRESSURE ON INITIATOR SENSITIVITY

Loading Pressure (1000 psi)	Drop Test Height (inch)
15	1.31
25	0.91
40	0.77
60	0.68
80	0.57

NOI. Priming Mix in MARK 102 Cups; 2 oz ball.

Since the resistance of solids to deformation does not change very much with moderate changes of deformation rate, the power dissipation by the displacement of explosive by a firing pin is nearly proportional to its velocity, which, in a drop weight system, is proportional to the square root of the drop height. The energy, on the other hand, is proportional to the product of the height and the weight. This energy-power relationship is shown in Figure 5.

*c. Percussion Initiation.* As in stab initiation, the function of the percussion firing pin is to transform energy into highly concentrated heat. However, contrary to initiation by stab, the firing pin does not puncture the case in percussion initiation. Rather,

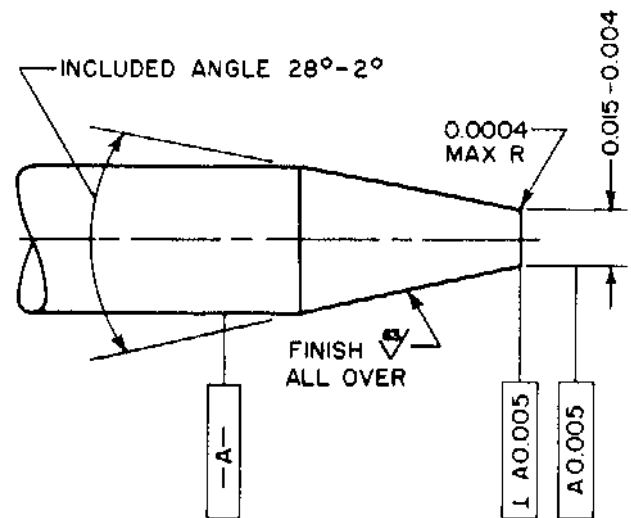

Figure 9. Standard Firing Pin for Stab Initiators

the pin dents the case and pinches the explosive between anvil and case. Energy must be supplied at a rate sufficient to fracture the granular structure of the explosive. Criteria for percussion firing pins have not been refined to the same degree as those for stab pins. It has been established that a hemispherical tip gives greater sensitivity than a truncated cone and that tip radius has little effect on sensitivity. Typical radius is 0.050 inch.

A study on the effect of firing pin alignment showed that there is little effect if the eccentricity is less than 0.02 inch. Above 0.04 inch eccentricity, sensitivity decreases rapidly because of primer construction. Sensitivity also decreases as the rigidity of primer mounting is decreased. In general, a study of the relationship of cup, anvil, explosive charge, and firing pin has shown that sensitivity variations appear to depend on the nature of primer cup collapse rather than on explosion phenomena themselves.<sup>6</sup>

The effect of firing pin velocity results in the same general hyperbolic energy-velocity relationship as that of other initiators (see Fig. 10<sup>10</sup>).

From experimental data it can be inferred that stab and percussion initiations occur by different mechanisms. Kinetic energy appears to be the determining magnitude for stab initiation, momentum for percussion.

### 23. Initiation by Other Means

*a. Friction.* The importance of frictional heating in the initiation of explosives has been demonstrated by several investigators.<sup>1</sup> The importance of this type of initiation with respect to handling hazards



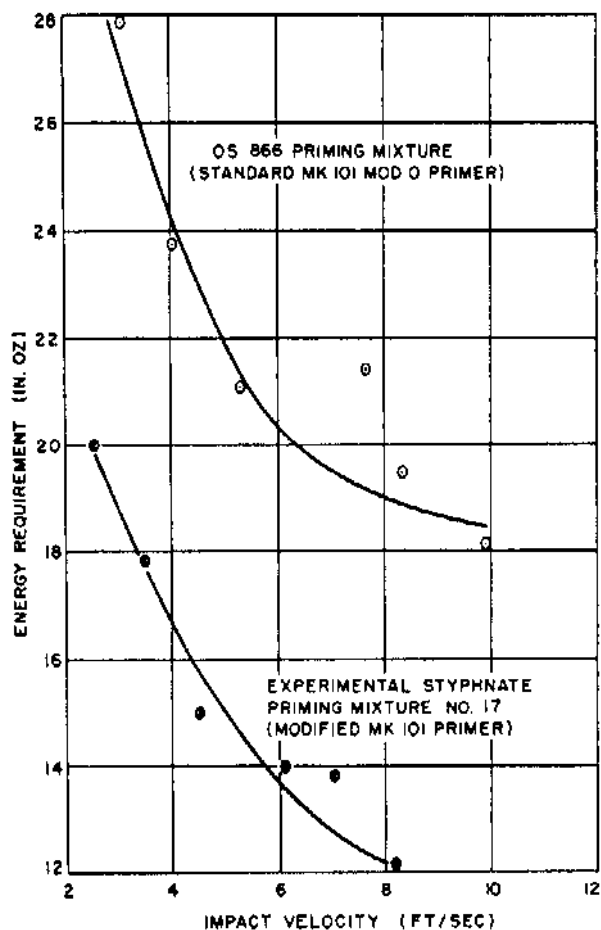

Figure 10. Energy-Velocity Relationship for Percussion Primers

is attested by the experience of press loading activities, namely "press blows" are much more frequent during pellet ejection and ram extraction than during the actual pressing phase. However, no quantitative means of measuring this property is

in current use. Perhaps the most pertinent data regarding friction sensitivity are those shown in Table 9<sup>1</sup> which relate impact sensitivity to melting point and hardness of the intermixed grit.

*b. Electric Sparks.* The initiation of explosives by electric sparks is of interest with respect to hazards of use. An individual may carry a charge of a few hundredths of a joule on his body, which if discharged could initiate explosives.<sup>19</sup> It has been found that the energy required for initiation is highly dependent upon physical and electrical characteristics of the discharge system and the form of the explosive (see Table 10).<sup>16</sup>

The military application consists of "high tension" initiators which are ignited by electric sparks (see Paragraph 50). A number of experimental detonators are also being studied.<sup>7,20</sup> The sensitivity of common military explosives to static electricity is shown in Table 20.

*c. Exploding Wires.* Exploding bridgewire (EBW) devices are a recent development in explosive materiel. Of course, almost any bridgewire may be made to explode if subjected to a sufficiently rapid and energetic electrical discharge. However, the feature which classifies an item as an EBW device is that it will fire *only* if subjected to such an impulse. Lesser energies or lower rates will burn out the bridge without initiating the explosive. The key feature of exploding bridgewires is that they can initiate secondary explosives directly and hence result in insensitive initiators.

The exploding wire phenomenon as well as that of the initiation of explosives thereby is complex. The rate at which the energy can be delivered is limited by circuit inductance, impedance mis-

TABLE 9. INITIATION OF EXPLOSION BY FRICTION OF PETN IN THE PRESENCE OF GRIT

Grit added	Hardness (Mohs' scale)	Melting point (°C)	Friction explosion efficiency (percent)	Impact explosion efficiency (percent)
Nil (pure PETN)	1.8	141	0	2
Ammonium nitrate	2-3	169	0	3
Potassium bisulphate	3	210	0	3
Silver nitrate	2-3	212	0	2
Sodium dichromate	2-3	320	0	0
Potassium nitrate	2-3	334	0	0
Potassium dichromate	2-3	398	0	0
Silver bromide	2-3	434	50	6
Lead chloride	2-3	501	60	27
Silver iodide	2-3	550	100	-
Borax	3-4	560	100	30
Bismuthinite	2-2.5	685	100	42
Glass	7	800	100	100
Rock salt	2-2.5	804	50	6
Chalcocite	3-3.5	1100	100	50
Galena	2.5-2.7	1114	100	60
Calcite	3	1339	100	43

TABLE 10. THRESHOLD IGNITION ENERGIES

<i>Material</i>	<i>Metall/metal electrodes (no added circuit resistance)</i>		<i>Rubber/metal electrodes (10<sup>5</sup> ohm series resistance)</i>	
	<i>Contact sparks (500 μμf)</i>	<i>Gaseous sparks (1000 μμf)</i>	<i>Minimum energy</i>	<i>Minimum capacity (μμf)</i>
Lead azide	20	10,000	2250	500
Lead styphnate	60	—	20	5
Lead dinitroresorcinate	—	—	1250	25

*Notes:* (1) The energy value quoted is the energy (erg) stored on the capacitor; the energy dissipated in the gap is about one-tenth of this.

(2) The gaseous and contact spark regions of sensitiveness are continuous with lead styphnate.

match between cable and bridgewire and skin effect in the bridge, which raise the effective resistance to several ohms during the initial stage of the discharge. As the discharge continues, the temperature increase in the wire maintains its resistance in this range. The discharge time is thus increased to about two microseconds which is long enough, even at sonic velocity, for a shock envelope to expand to a few hundred times the volume of the wire. Thus, the energy density may be so low that it is surprising that explosion is initiated.

Gleaned from many research studies,<sup>21-23</sup> the following practical generalities may serve as a guide to applications of EBW devices

(a) Firing units should consist of special high-rate discharge condensers and of switches with minimum inductance and transient resistance so that the rate of current rise is on the order of 10<sup>9</sup> amperes per second. Triggered spark gap switches are most frequently used.

(b) Transmission lines should be as short as possible. For more than a few feet of transmission line, special "flat" low impedance cable is desirable. All connections must be firm and of negligible resistance.

(c) Bridgewires of pure metals rather than

higher resistance alloys are more efficient for EBW purposes. Although silver and copper are satisfactory in the laboratory, platinum and gold have been preferred for military items because of their resistance to corrosion. Diameters between one and a half and two mils appear to be optimum for initiation of such explosives as PETN.

(d) The state of aggregation of the explosive around the bridgewire is quite critical. Loading densities much higher than one gram per cubic centimeter greatly increase the energy requirement for initiation. This increase is so great as to make devices loaded at higher densities inoperable for practical purposes. Fine particle size is also essential.

(e) The reaction initiated by an EBW in secondary explosives appears to be a low order detonation. Time measurements indicate initial velocities which are definitely supersonic yet well below the stable rates for the explosives and loading densities used. The densities and particle sizes used in EBW detonators are such that detonation of PETN grows to its stable rate in a few millimeters. For other material, such as RDX, confinement and other measures to augment this transmission are desirable.

## REFERENCES

### CHAPTER 2

*a-i Lettered references are listed in Paragraph 12 (end of Chapter 1).*

1. F. P. Bowden and A. D. Yoffe, *Initiation and Growth of Explosives in Liquids and Solids*, Cambridge University, Monographs on Physics, Cambridge University Press, New York, 1952.
2. M. A. Cook, *The Science of High Explosives*, Reinhold Publishing Corporation, New York, 1958.
3. S. J. Jacobs, *Closed Bomb Burning of High Explosives and Propellants*, (from Explosive Research Laboratory) Office of Scientific Research and Development, OSRD Report 6329, January 22, 1946.
4. J. W. Taylor, "The Rapid Burning of Secondary Explosives by a Convective Mechanism," *Third Symposium on Detonation*, Office of Naval Research, Navy Dept., Report ACR-52, Vol. 1, pp. 77-87, September 26-28, 1960.
5. R. H. Stresau, *Low Velocity Detonation of Certain Primary Explosives*, Naval Ordnance Laboratory (White Oak), NAVORD Report 2460, 28 May 1962.
6. N. Griffiths and J. M. Grocock, *The Burning to Detonation of Solid Explosives*, Part 1, "Ionization Probe Studies in Confined Channels," ARDE Report (MX) 5/59, Ministry of Supply, Armament Research and Development Establishment, Fort Halstead, Kent, England, March 1959.
7. *Proceedings of the Electric Initiator Symposium (U)*, Held at The Franklin Institute November 29-30, 1960, Report F-A2446, Papers 14 to 18, 27 (AD-323 117) (Confidential).
8. A. Macek, "Transition From Deflagration to Detonation in Cast Explosives," *J. Chem. Phys.*, 31, 1, 162-167 (1959).
9. J. Pearson and J. Rinehart, *Behavior of Metals Under Impulsive Loads*, American Society for Metals (1954).
10. H. J. Hugoniot, de l'Ecole Polytech, 57, 3 (1887): 58, 1 (1888).
11. C. F. Curtiss and J. O. Hirschfelder, *Thermodynamic Properties of Air*, University of Wisconsin Naval Research Laboratory, Report CF-793, April 1948.
12. *Second ONR Symposium on Detonation*, Office of Naval Research, Navy Dept., February 9-11, 1955, Papers 15 to 18, pp 205-285.
13. H. Eyring et al., "The Stability of Detonation," *Chemical Reviews*, 45, 1, 69-181, (1949).
14. L. D. Hampton and R. H. Stresau, *Small Scale Technique for Measurement of Detonation Velocities*, Naval Ordnance Laboratory (White Oak), NAVORD Report 2282, 27 December 1951.
15. P. W. Cooper, *Low Firing Energy Detonator Containing No Primary Explosives*, Final Report, Contract DA-11-022-501-ORD-2892, Armour Research Foundation, 15 June 1960.
16. F. P. Bowden et al., "A Discussion of the Initiation and Growth of Explosion in Solids," *Proc. Royal Society, Series A, Mathematical and Physical Sciences*, 246, 1245 (1958).
17. R. McGill and P. Holt, Eds., *Proceedings of the Gilbert B. L. Smith Memorial Conference on Explosive Sensitivity (U)*, Naval Ordnance Laboratory (White Oak), NAVORD Report 5746, 2 June 1958 (Confidential).
18. J. Wenograd, "The Behavior of Explosives at Very High Temperatures," *Third Symposium on Detonation*, Office of Naval Research, Navy Dept., Report ACR-52, Vol. 1, pp. 60-76, September 26-28, 1960.
19. F. W. Brown, D. J. Kusler and F. C. Gibson, *Sensitivity of Explosives to Initiation by Electrostatic Discharges*, Bureau of Mines, Report of Investigations 5002, September 1953.
20. J. M. A. de Bruyne and J. A. McLean, "The Initiation of Booster Type Explosives by Low Energy Spark Discharges," American Cyanamid Co., Contract DA-49-186-502-ORD-537, 1 April 1957.
21. M. T. Hedges, *Development of Exploding Wire Initiators*, Picatinny Arsenal, Initiator and Explosives Application Section, Artillery and Rocket Development Laboratory, Report 84, April 1960.
22. W. G. Chace and H. K. Moore, Eds., *Exploding Wires*, The Plenum Press, New York, 1959.
23. *Proceedings of the HERO Congress (U)*, held at The Franklin Institute May 24, 25, and 26, 1961, Report F-A2424, Contract N178-7705, papers 12, 23, 25 (AD-326 263) (Confidential).

## DETONATION TRANSFER AND OUTPUT

A. EFFECTIVENESS OF ONE CHARGE  
IN INITIATING ANOTHER

## 24. Detonation Propagation

In some cases, two charges are in such close contact that the transfer of detonation from one to another is indistinguishable from the propagation within a single continuous charge. More often, however, packaging, structural and fabrication considerations result in the interposition of gaps and barriers of such magnitude that the agency of transmission is nonreactive shock, blast, flying fragments or some combination of these. The conditions induced by such agencies differ in important respects from those of stable detonation. In general, it takes time and space to re-establish these conditions in the receptor charge.

Figure 11 illustrates a detonation front as recorded by a streak camera. Investigators agree that detonation of the receptor first occurs at a point within the receptor charge rather than at surface exposed to the initiating impulse.<sup>1</sup> Although this phenomenon must be taken into account in the design of initiation systems for main charges whose effectiveness is critically influenced by the form of the detonation wave front, it is generally ignored in other explosive train charges. For most practical purposes, transfer of detonation is considered in terms of the probability that high order detonation will be induced in the receptor.

High order detonation is defined as that in which the detonation rate is equal to or greater than the stable detonation velocity of the explosive. It is rarely practical, however, to instrument real charges for detonation rate measurements. Hence,

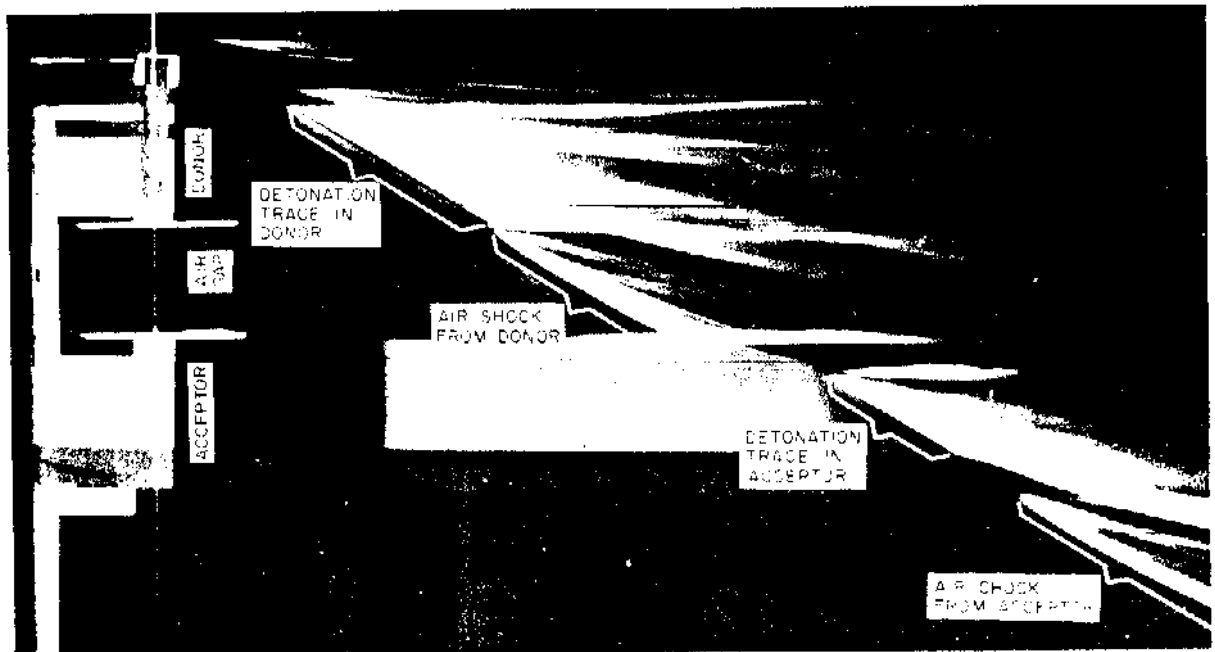

Figure 11. Streak Camera Record of Detonation

Courtesy  
BALLISTIC RESEARCH LABS  
ABERDEEN PROVING GROUND

high order detonation is generally considered to be a reaction whose effects are not significantly less than the maximum which has been observed with a charge of the type in question. For main charges, high order may be considered in terms of the desired effects of the charge. Booster charges, as usually used, tend either to detonate high order by almost any criterion or to fail completely.

A proposed law of similitude for sympathetic detonation states that the critical distance for transmission between one explosive charge and another varies with the cube root of the weight of the donor charge.<sup>2</sup> However, where the intervening space was filled with air rather than solids, a trend was noticed toward a relationship of the 2/3 power of the charge weight.<sup>3</sup>

### 25. Dimensional Interactions

The effectiveness of one charge in initiating another is determined by the interaction of the properties of the explosive, its loading density, and the dimensions and confinement of the charge. The interaction is such that it would be impractical to discuss these factors separately, except in broad generalities.

Although, as might be expected, the effective output of a donor charge increases systematically with its diameter, the relationship between acceptor diameter and sensitivity is more complex (see Fig. 12<sup>a</sup>). Note that the optimum diameter of an acceptor, from the point of view of the air gap across which it can be initiated, is slightly less than the diameter of the donor. This relationship applies specifically to well confined columns of explosive.

As might be expected, the increase in the weight of a donor charge is more effective in increasing output if it is due to a diameter increase than to a length increase (see Fig. 13<sup>b</sup>).

Most experimental determination of the relative effectiveness of explosive charges in initiating other charges has been done as part of a study of a specific system. Hence, the variables are generally so intermingled as to make generalizations from such data difficult. However, the evidence that the volume of dent which a charge makes in a steel block is nearly proportional to its effectiveness as an initiator, combined with relatively broad and interpretable plate-dent data, makes it possible to derive relationships which appear to have relatively broad applicability.<sup>4</sup>

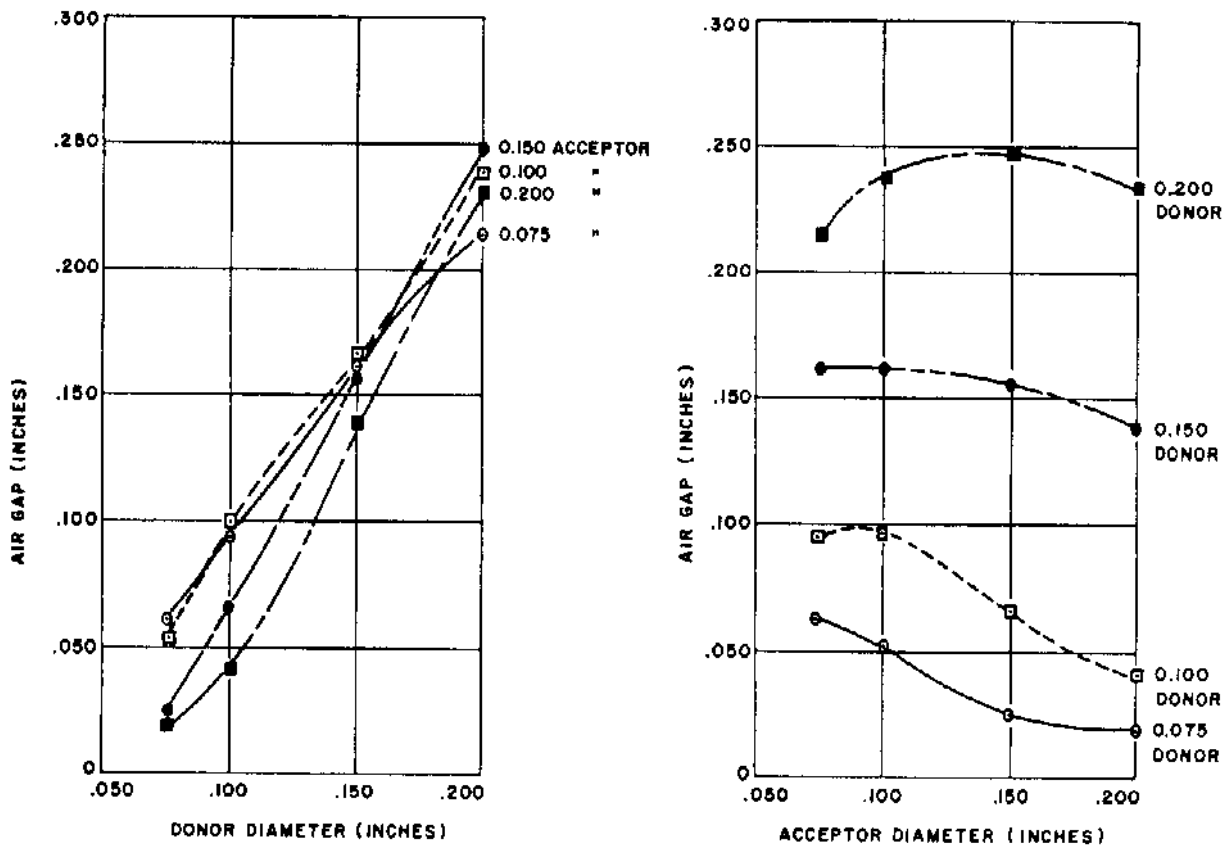

Figure 12. Critical Gap as a Function of Column Diameter

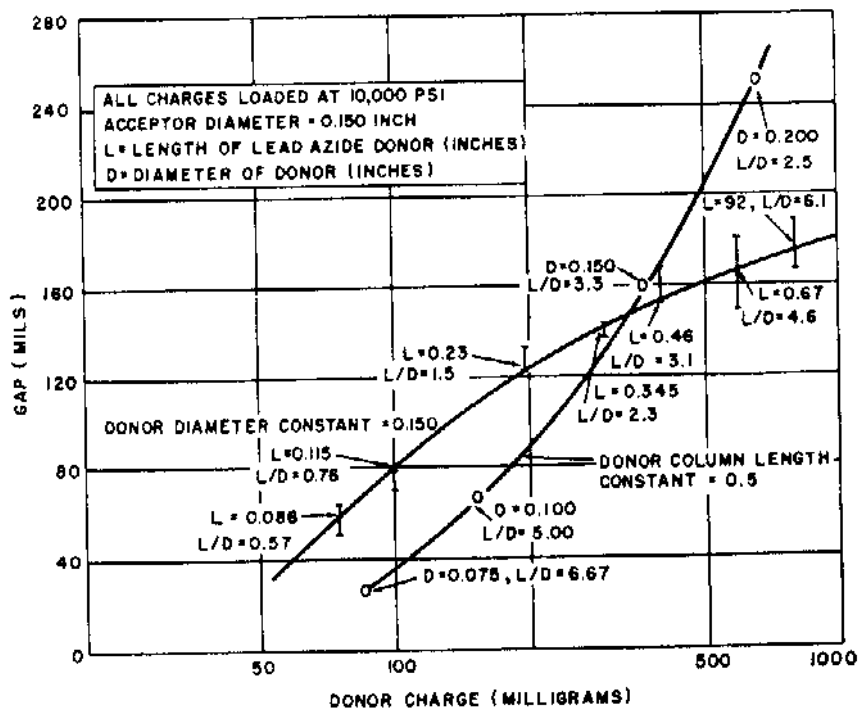

Figure 13. Critical Axial Air Gaps Across Which Detonation Is Transmitted Between Lead Azide and Tetryl

Confinement has a significant effect. In relatively thin-walled containers, confinement is related to the weight ratio of case to charge. For heavily confined charges (where the wall thickness exceeds the charge radius) the shock impedance of the confining material is a good criterion of confinement effectiveness. Shock velocities of various metals are listed in Table 11 (see also Paragraph 52).

TABLE 11. DENSITIES AND SHOCK VELOCITIES IN VARIOUS METALS

Metal	Density (gm/cc)	Shock Velocity (mm/microsec)
Aluminum	2.71	7.00
Babbitt	9.73	3.25
Brass	8.50	4.57
Bronze	8.80	4.82
Copper	8.9	4.6*
Lead	11.3	2.1*
Magnesium	1.76	7.83
Steel	7.85	5.30
Zinc Alloy (die cast)	6.60	3.95

\*Ref. 5

## B. SENSITIVITY TO INITIATION

### 26. Sensitivity Tests

*a. Standard Tests.* The sensitivity of an explosive charge to initiation by another is the result of the interaction of a number of variables. This interaction has not been reduced to a formula. However, a review of available tests should help the designer to develop an intuitive grasp of the effects and

interactions of the various factors involved. The fact that results obtained by various procedures differ does not necessarily imply that one is right and another wrong or that one is necessarily better. Each may be completely valid as a measurement of the sensitivity of an explosive under the conditions of the test.

One test employed to measure sensitivity to initiation is the booster sensitivity test in which a gap between donor and test charge is filled with wax (see Paragraph 107 for a description of the test). Typical results are shown in Table 12.<sup>6</sup> The 50% gaps were determined by means of Bruerton tests (see Paragraph 106). Results of several other tests are compared in Table 13.

*b. Gap Tests.* The small scale air-gap test has been employed by a number of investigators. In this test, donor and acceptor explosives are separated by a variable air gap (see Figure 14).<sup>6</sup> Gap distance is the measure of sensitivity.

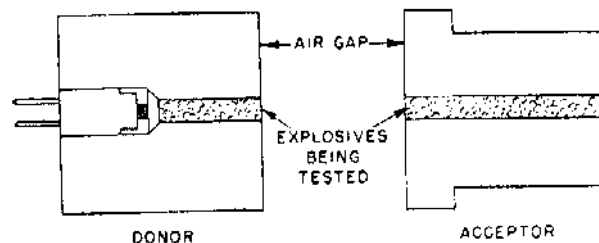

Figure 14. Small Scale Air Gap Test

TABLE 12. TYPICAL RESULTS OF BOOSTER SENSITIVITY TEST

Explosive	Preparation	50% Gap (in.)	Density (gm/cc)
Amatol 80/20	Pressed	0.83	1.65
Amatol 50/50	Cast	0.60	1.55
Composition A-3	Pressed	1.70	1.62
Composition B	Cast	1.40	1.69
Composition C	Pressed	1.36	1.56
Composition C-3	Pressed	1.36	1.62
Cyclonite (RDX)	Pressed	2.33	1.54
DBX	Cast	1.35	1.76
Ednatol 55/45	Cast	1.28	1.62
Explosive D (Ammonium Picrate)	Pressed	1.27	1.54
Haleite (EDNA)	Pressed	2.09	1.42
Minol-2	Pressed	1.46	1.74
Nitroguanidine	Pressed	0.67	1.41
Pentolite 50/50	Pressed	2.36	1.61
Pentolite 50/50	Cast	2.08	1.65
Picratol 52/48	Cast	1.00	1.63
Tetryl	Pressed	2.01	1.58
Tetrytol 75/25	Cast	1.66	1.66
TNT	Pressed	1.68	1.55
TNT	Cast	0.82	1.60
Tritonal 80/20	Cast	0.58	1.75

In Figure 15,<sup>4</sup> results of this test are compared with average impact sensitivity results. Impact data for the various explosives were compared with results obtained with the small scale gap test. This test consists of determining the minimum priming charge by loading the explosive into a cup of a blasting cap with a priming charge of DDNP. Both donor and acceptor were loaded at 10,000 psi. Bruceton tests of from fifteen to fifty trials formed the basis of the estimates of the gap. For these tests, the logarithm of the gap length was assumed to be a normalizing function.

A refinement of the small scale gap test is illustrated in Figure 16.<sup>11</sup> Here, a steel dent block is added and the gap filled with Lucite. Further, data are analyzed by the gap decibang method. The gap decibang  $DB_g$  is analogous to the decibel in that it expresses not an absolute energy or stimulus but rather a comparison with some arbitrarily established reference level.

This method of expressing explosive sensitivity is based on a function which transforms sensitivity data into a normal distribution in which the explosive response increases with increased initiation intensity. Because the initiation intensity is in-

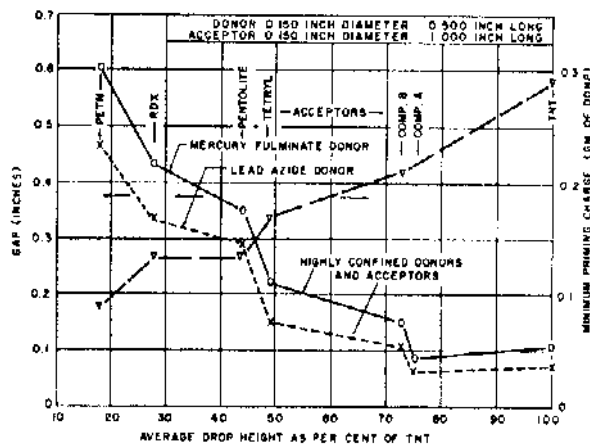

Figure 15. Minimum Priming Charge and Gap for Critical Propagation

TABLE 13. INITIATION SENSITIVITY MEASURED BY SEVERAL TESTS

Explosive	Min. Prim. <sup>a</sup> Chg. (gm)	Impact Tests			Crit. Air Gap <sup>d</sup> 0.2 in. Diam. (in.)	Crit. Lucite Gap <sup>e</sup> 50% Gap (in.)	Crit. Lucite Gap <sup>f</sup> (DB <sub>g</sub> )
		PA <sup>b</sup> (in.)	Bu. Mines <sup>b</sup> (cm)	ERL <sup>c</sup> No. 12			
Composition B (Desens.)	0.19	14(17)	95	82	—	0.266	55.75
Cyclonite (RDX)	—	8(18)	32	—	0.318	0.470	3.28
Cyclonite/Wax	—	—	—	—	—	—	—
99/1	—	—	—	34	—	—	—
98/2	—	—	—	35	—	—	—
97/3	—	—	—	43	—	—	—
95/5	—	—	—	47	—	—	—
91/9 (Comp. A-3)	0.21	16(17)	> 100	—	—	—	—
Cyclonite/Calcium Stearate	—	—	—	—	—	—	—
99.3/0.7	—	—	—	—	—	0.392	4.07
98.6/1.4	—	—	—	23	—	0.332	4.79
98.0/2.0	—	—	—	37	0.144	0.313	5.04
97.2/2.8	—	—	—	32	—	0.299	5.25
Pentolite, 50/50	0.12	12(15)	34	38	—	—	—
10/90	—	14(18)	65	—	—	—	—
PETN	0.09	6(16)	17	—	0.47	—	—
Tetryl	0.17	8(18)	26	—	0.184	0.434	3.63
Tetrytol, 70/30	0.19	11(18)	28	—	—	—	—
TNT, Pressed	0.25	14(17)	> 95	—	—	0.281	5.52
Cast	—	—	—	—	—	0.021	16.7

<sup>a</sup>Ref. 7. Table shows charge in grams of DDNP to initiate material pressed to density of 1.4 grams per cc.

<sup>b</sup>Ref. g. Figures in parentheses are sample weights in milligrams.

<sup>c</sup>Ref. 9, 10.

<sup>d</sup>Ref. 8.

<sup>e</sup>Donor—RDX, 1 inch long, 0.2 inch diameter. Pressed in steel at 10 kpsi.

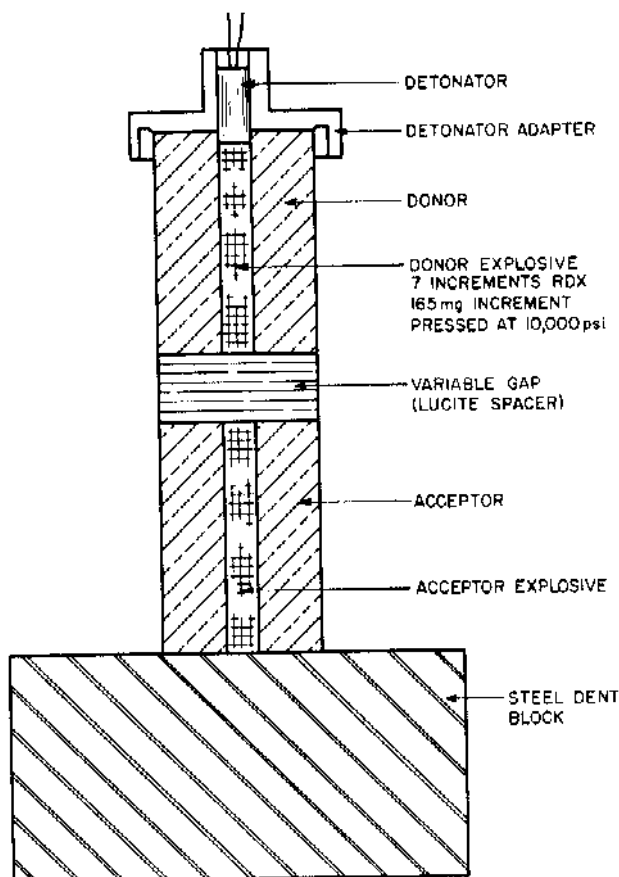

Figure 16. Small Scale Lucite Gap Test

creased by reducing the attenuation of the output of a standard donor, the transformation function will show the stimulus to be an inverse function of barrier thickness. The transformation function is

$$X = A + 10 B \log G_r/G_t \quad (24)$$

where  $X$  is the stimulus expressed in  $DB_g$ ,  $A$  and  $B$  are arbitrary constants,  $G_r$  is the reference gap, and  $G_t$  is the observed (test) gap. The reference gap  $G_r$  has been selected to be 1.0 inch using a high-intensity RDX-loaded donor.

Corresponding values of decibang intensity and gap thickness are shown in Table 14. Table 15<sup>11</sup> lists sensitivities of some explosives in gap decibangs as determined by the small scale Lucite gap test. It is possible that the method of gap decibang analysis may have a broader application than that of an arbitrary intensity measure. It may serve, for example, as a unit of effective initiating output of detonator, lead, or booster. The relationship between the dent produced by a donor acting through a barrier or gap and the gap decibang level of the combination appears to be linear.

TABLE 14. RELATION OF DECIBANGS TO GAP THICKNESS

Intensity ( $DB_g$ )	0	3	6	9	10	13	16	19	20
Thickness (mil)	1000	501	251	126	100	50.1	25.1	12.6	10.0

## 27. Variables Affecting Sensitivity

*a. Loading Density.* The voids which are present in most explosive charges affect the initiation sensitivity by providing reaction nuclei and by reducing the pressure in the reaction zone. These effects, of course, interact with those of charge size, confinement, and the nature of the transmitting medium. Results obtained with pressed, granular explosives in the wax gap sensitivity test are plotted in Figure 17.<sup>12</sup> For material with less than one percent voids, failures were observed with no barrier at all. Results with small scale gap tests were similar. Some data are included in Table 15.<sup>13</sup> Figure 18<sup>13</sup> shows the results of a test with RDX, tetryl, and TNT.

*b. Lot-to-lot Variations.* The variable with the largest effect on lot-to-lot uniformity is loading density. While there are other differences in explosives which cannot be explained in terms of density effects alone, these are difficult to pinpoint and even more difficult to control.<sup>8,12</sup> Particle size and its distribution are variables which have been shown to have an appreciable effect on the sensitivity of explosives in most cases.

TABLE 15. SENSITIVITIES OF SOME EXPLOSIVES ACCORDING TO THE SMALL SCALE LUCITE GAP TEST

Explosive	Loading Pressure (kpsi)	Loading Density (gm/cc)	Sensitivity ( $DB_g$ )
Cyclonite (RDX)	10.0	1.5649	3.283
Cyclonite (RDX)	38.2	1.7373	5.069
TNT	Cast	1.5746	16.5
TNT	6.2	1.4078	4.635
TNT	19.0	1.5835	6.114
Tritonal	Cast	2.0557	17.5

*c. Additives.* The addition of a few percent of a waxy substance, such as calcium stearate, reduces the sensitivity of RDX by a factor of two or three, as indicated by the air gap test. This effect may be noted in Table 13, although on closer consideration, it is apparent that a large measure of this desensitization is attributable to the higher density attainable at the same loading pressure when a lubricant is added.

In Table 16, the effects of added wax on the sensitivity of a number of cast explosives are given as measured by the wax gap booster sensitivity test.



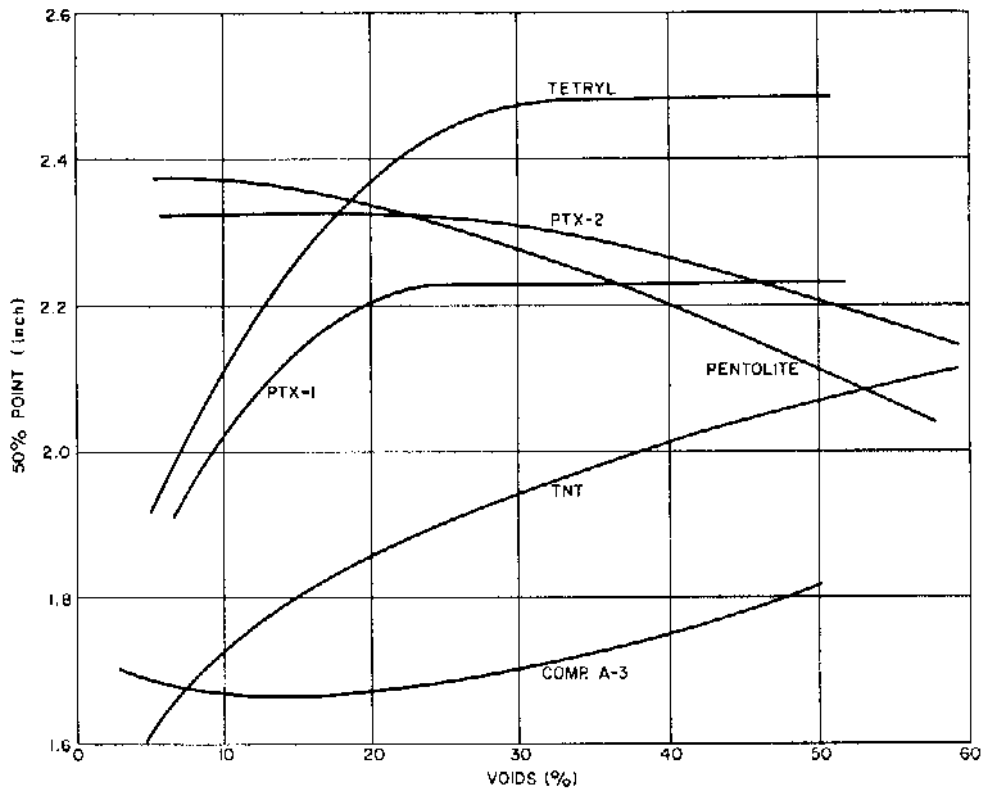

Figure 17. Effect of Voids on Booster Sensitivity (Wax Gap Test)

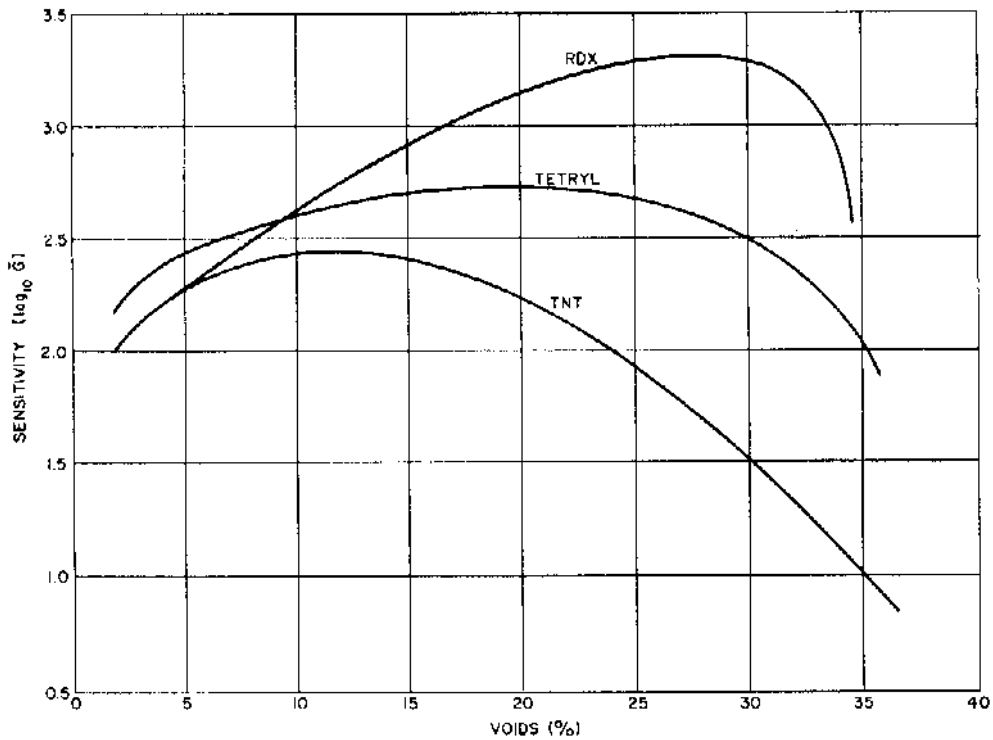

Figure 18. Effect of Voids on Booster Sensitivity (Lucite Gap Test)

**TABLE 16. EFFECT OF 5 PERCENT D-2 WAX ON THE BOOSTER SENSITIVITY OF VARIOUS CAST EXPLOSIVES (Wax Gap Test)**

Explosive	Unwaxed	Waxed	Difference
Baronal	0.86	0.64	-0.22
Comp. B	1.32	1.16	-0.16
Pentolite	2.08	1.96	-0.12
Picratol 52/48	1.00	0.88	-0.12
PTX-2	1.87	1.63	-0.24
TNT	0.82	1.03	+0.21
Tritonal 80/20	0.58	1.04	+0.46

d. *Confinement.* Critical air gaps as determined by the test illustrated in Fig. 14 are related to confining media of the acceptors used as shown in Figure 19. However, as may be seen in Table 17,<sup>14</sup> the agreement is somewhat less than perfect.

The sum of a dimensionless density with a dimensionless Brinell hardness has been proposed to relate the effect of the confining medium to

sensitivity. This relation is shown in Figure 20.<sup>15</sup> Almost the identical plot results if Brinell hardness is replaced with a dimensionless strength. All of the above data were obtained with tetryl acceptor charges. The effect of confinement upon sensitivity varies considerably from one explosive to another.<sup>2</sup> For small columns the differences become more marked.

**TABLE 17. AIR GAP SENSITIVITY RELATED TO ACOUSTIC IMPEDANCE OF ACCEPTOR CONFINING MEDIUM**

Confining Medium of Acceptor	Shock Impedance of Acceptor Confinement (megarayl)	Critical Air Gap* (in.)
Lucite	0.7	0.063
Magnesium	1.4	0.088
Zinc (die cast)	2.6	0.101
Babbitt	3.2	0.148
Brass	3.9	0.153
Steel (SAE 1020)	4.2	0.260

\*Lead azide to tetryl, 0.150 inch diameter columns

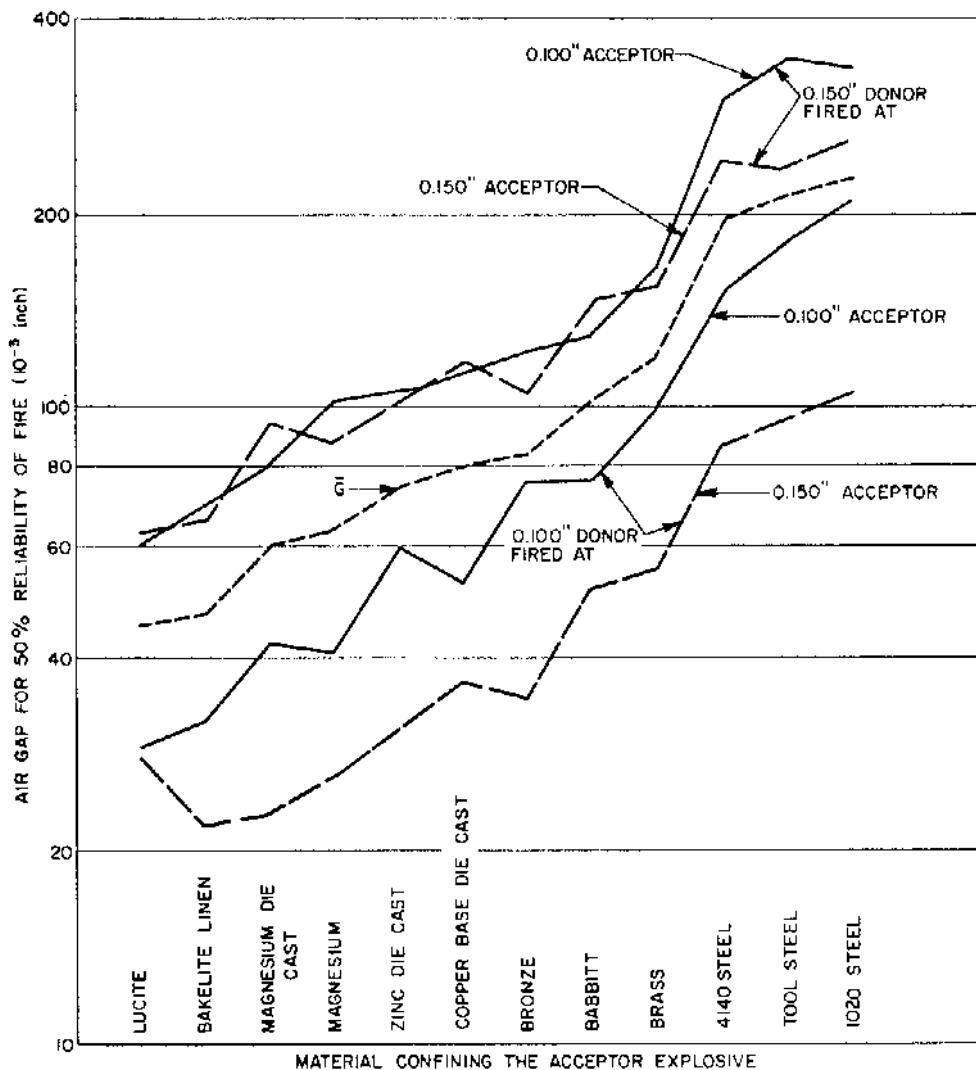

**Figure 19. Effect of Acceptor Confining Material upon Sensitivity in an Air Gap Test**

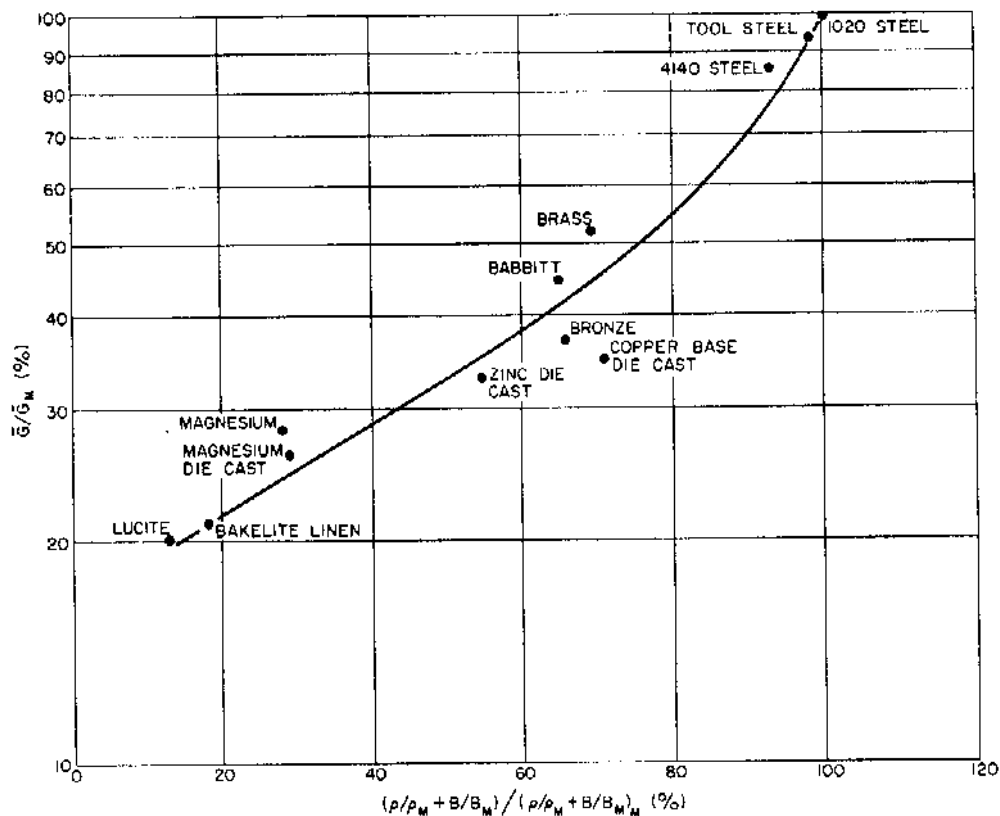

Figure 20. Gap Sensitivity Related to Density and Hardness of Acceptor Confining Medium

*e. Gaps and Barriers.* In one way or another, gaps, barriers or spacer materials are components of explosive systems. In some instances, these features are designed into a train to achieve a desired effect. In other cases, they are inherent to construction just as is confinement. Bottoms of cups are barriers and manufacturing tolerances introduce gaps. In some instances, the combination of gaps and barriers are beneficial. For example, barrier fragments have transmitted detonation over a gap which was sometimes forty times that across which the air blast wave alone could carry it.

Available experimental data relating the variables are not complete. Figure 52 compares performance under service conditions for several gap and barrier combinations both unconfined and confined. In Table 18<sup>6</sup> the effect of changing the spacer material in the wax-gap booster test is given for four explosives and a number of spacer materials. Attention is directed to the air gap data. It has been suggested that the mechanism of transmission across an air gap to the more sensitive materials must involve factors other than shock pressure.

TABLE 18. SENSITIVITY FOR VARIOUS SPACER MATERIALS (Wax Gap Test)

Spacer Material	50 Percent Point (in.)			
	Tetryl	Comp. B	HBX	Pentolite
Air	5.04	1.21	0.93	5.01
Wood (oak)	1.39	1.04	0.93	1.47
Copper	1.69	1.17	0.86	1.92
Polystyrene	1.85	1.43	1.19	1.90
Acrax B	1.89	1.46	1.28	2.08
Aluminum	1.90	1.51	1.33	2.05
Stanolind Wax	2.07	1.50	1.28	2.06

## 28. Misaligned Charges

Out-of-line safety is a general requirement of fuzes. The usual situation is that of two well confined columns of explosives, one of which is displaced laterally with respect to the other as in Figure 21.<sup>a</sup> Propagation occurs near the point where the expanded hole of the donor becomes tangent to the original acceptor charge. In an experiment with PETN and RDX, transmission occurred when the charges were displaced somewhat beyond the point of tangency. It was also observed that these explosives sometimes detonated from an apparent central initiation point. Out-of-

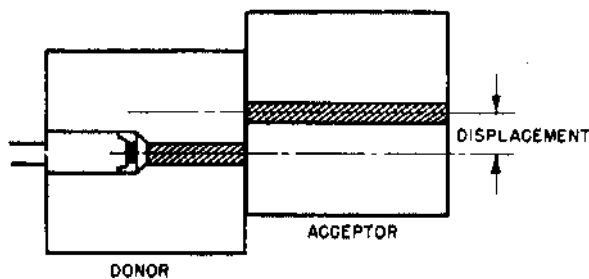

Figure 21. Arrangement for Propagation of Misaligned Charges

line safety should always be tested to make certain that the train does not propagate in the safe position (see Paragraph 110).

### C. OUTPUT

#### 29. Nature of Explosive Output

The mechanism whereby useful output is derived from an explosion is essentially that of a heat engine. Heat is transformed into mechanical energy by the adiabatic expansion of hot, compressed gas. As a heat engine, the detonation of a military high explosive is remarkably efficient. Over seventy percent of the theoretical heat of explosion usually appears as measurable mechanical output. However, the effectiveness of an explosive charge in any particular application is not necessarily directly related to its total mechanical energy output. Only a small fraction of the energy usually reaches the target and, of this, most is usually either reflected or absorbed without damage to the target. Hence, effectiveness is characterized in terms of the various phenomena which are utilized to transmit the output to the target. These phenomena include shock waves, gross movements of such intervening media as air, water or earth, and the projection of metal or other materials which are inert components of explosive ordnance items. All of these phenomena accompany most explosions, but the partition of energy between them varies greatly with variation of design and composition, as do other quantities associated with each phenomenon which may be more important than energy in determining relative effectiveness.

For these reasons, characterization of the output of an explosive charge in terms of the phenomena involved in its intended application is the most valid basis for comparison with charges of other designs and loadings. Examples of such phenomena are blast and fragmentation.

The theory of detonation waves is described in Paragraph 19. The calculations discussed are

based on a number of assumptions which include ideal detonation (Chapman-Jouguet conditions) and a certain reaction chemistry. Although in many investigations agreement has been attained between experiment and theory, many of the most interesting and important aspects of the output behavior of real charges stems from their nonideality — from deviations in their chemical or thermodynamic behavior from those commonly assumed. For these reasons, more quantitative predictions of performance are made by use of the empirical relationships based on measurements of output phenomena.

An introduction to actual detonations, those which are theoretically nonideal, is also contained in Paragraph 19.

#### 30. Effect of Charge Configuration

*a. The Detonation Front.* As a first approximation, detonation may be considered to propagate in all directions within a homogeneous charge at the same velocity. Thus, if a charge is initiated by a relatively concentrated source, the detonation front assumes a divergent spherical form. This curvature (convex in the direction of propagation) is accentuated at the boundaries of the charge (see Paragraph 19).

Such curvature, if its radius is small enough to be comparable with the reaction zone length, results in a reduction of detonation velocity and pressure from that associated with ideal detonation. The explosives used in applications where detonation pressure is a prime consideration (pentolite, Compositions A-3 and B and cyclotols) have reaction zone lengths of the order of a millimeter or less so that this effect is not usually important. However, with small charges of such materials as TNT, Explosive D or tritonal, they can assume importance. In addition, the pressure and its gradient vary radially. For some applications, most notably the controlled propulsion of solids, wave front profiles and pressure distributions other than those resulting from the action of hydrodynamic laws in simple charge configurations are desirable. For such purposes, special configurations have evolved.

One of the results of pressure variation behind the detonation front is the variation in momentum which the detonation wave imparts to solid objects. Where it is desired to propel an object of uniform thickness which has a relatively large area in contact with a charge, these variations in momentum

result in corresponding velocity variations which may result in distortion or even rupture of the object. This problem may be alleviated by either of two means although they are generally combined

- (a) distributing the explosive charge so as to reduce the variation in momentum transfer, or
- (b) adding mass at points where momentum is greatest.

The hydrodynamic relationships which determine momentum distribution in finite explosive charges are too complex to be solved analytically. However, they have been programmed for solution by computer.<sup>16</sup> Intuitive reasoning and cut-and-try development have yielded satisfactory designs in the past.

*b. Wave Shaping.* The control of the profile of detonation fronts has been the subject of much research.<sup>17</sup> All techniques are essentially applications of Huygens' principle which forms the basis of geometric optics. For ultimate refinement, account must be taken of the fact that detonation velocities are not precisely constant, but satisfactory control for many purposes is possible by designs which ignore the relatively small variations. The following four means of controlling the sequence of arrival of detonation waves at various points in a charge have been used<sup>17,18</sup>

- (a) Wave interrupters which require the wave to go around the interrupter,
- (b) Two explosives of appreciably different rates of detonation,
- (c) Density and composition variations in the explosive, and
- (d) Air, inert fillers, or both of such thickness as to delay the wave but not destroy it.

Perhaps the simplest devices for the control of wave front profiles are line wave generators. Those of the manifold type (Fig. 22) have been made by loading explosives into channels machined, molded, or cast into metal or other inert components

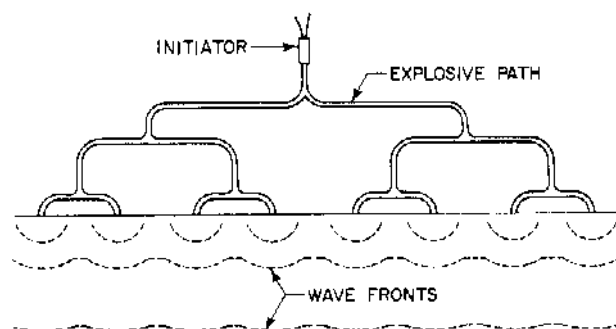

Figure 22. Line Wave Generator of the Manifold Type

and by constructing arrays of detonating cord. The detonating cord arrays were, of course, limited to relatively large systems by the spacing needed to prevent initiation or damage due to radial blast effects of adjacent cords.

The advent of mild detonating fuse (MDF) opens new possibilities in manifold type wave shaping devices (see Paragraph 87). In such applications, particular attention should be given the problem of transmission of detonation from the very small column diameter of MDF to the larger charges in which it is hoped to control the wave front profile. Even though reliable transmission is assured, the build-up may introduce enough time scatter to nullify the wave shaping effects. Step construction or a tapered lead should result in a satisfactory system.

Another line wave generator of the manifold type consists of perforated sheet explosive (see Fig. 23).

In addition to such generators, warped surfaces may be used to produce line waves of any desired curvature. The circular front generated by the point initiated detonation of a plane charge may also be modified by warping the plane and by transmission to other explosive surfaces. One example, illustrated in Figure 24, is the generation of a straight line wave by means of warped sheet explosive.

### 31. Blast

Blast is the brief and rapid movement of air or other fluid away from a center of outward pressure, as in an explosion, or it is the pressure accompanying this movement. Physical manifestations of blast include (a) a shock front which is created by the rapidly expanding gases being opposed by the medium around the explosive, (b) a time period in which the pressure drops to ambient, (c) a continued pressure drop below ambient and finally (d) a

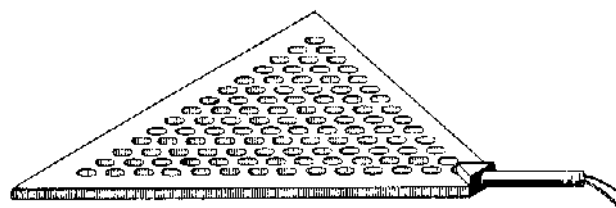

Courtesy  
E. I. DUPONT  
DE NEMOURS & CO., INC.

Figure 23. Line Wave Generator of Sheet Explosive

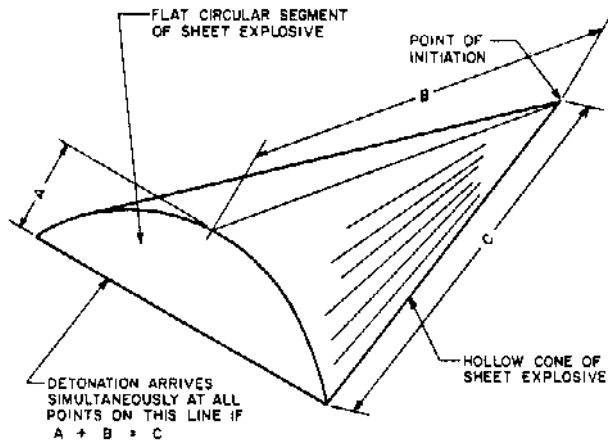

Figure 24. Line Wave Generator of Warped Sheet of Explosive

return to ambient pressure. Figure 25<sup>b</sup> shows this pressure-time relationship resulting from reactions of explosive charges. The area under the curve above ambient is called impulse.

The blast wave is produced by a process which may involve several steps. It always involves an initial explosion. It may be enhanced by the after-burning or reacting of the explosive products with themselves and with the oxygen in the air. It may also be enhanced by shock reflection from surfaces such as ground, water, or walls.

Blast decreases in magnitude at a ratio equivalent to the cube root of the distance from the charge. Blast pressures are plotted on graphs as  $P$  vs  $r/W^{1/3}$  where  $r$  is the distance from the charge and  $W^{1/3}$  is the cube root of the charge weight. Various design equations and graphs have been evolved for predicting the output from explosive charges, most of which are the results of empirical studies. The parameters which affect blast include

- (a) type of explosive
- (b) confinement
  - material used
  - thickness of material

- (c) configuration of explosive charge
- (d) effects of exterior media
  - atmospheric pressure
  - water
- (e) reflection of blast from surfaces
  - exterior blast
  - interior blast

The studies conducted with explosives showed that there exists a generalized relationship between energy of the explosive and the output in terms of peak pressure and impulse. An equation for estimating the blast pressures of cylindrical charges is available in classified literature.<sup>19</sup>

It was found that steel confined charges generally produced decreasing amounts of blast output with increasing thickness of confinement.<sup>20</sup> The only exception is a very thin steel confinement which appears to produce a blast output equal to or slightly better than bare charges. This is probably due to the fact that some unconfined charges break up partially during explosion. Certain materials when used as confining media for explosives appear to react in an explosive manner.<sup>21</sup> That is, they increase the blast output when they confine explosives. Some rubbers and plastics exhibit this behavior.

Studies of the effects of altitude on blast showed that there is a constant decrease in blast output with altitude.<sup>22</sup> For practical purposes, there is a 1% decrease in excess pressure for every 1000 ft altitude.

The foregoing studies were concerned with exterior blasts far from ground or reflective surfaces. If the charge is exploded close to a surface, the shock wave which reaches this surface will be partially reflected. The reflected wave may subsequently catch up with the original shock wave and reinforce it. The reason for its catching up is that the reflected wave travels through the hot gases of the explosive where its velocity is greater.

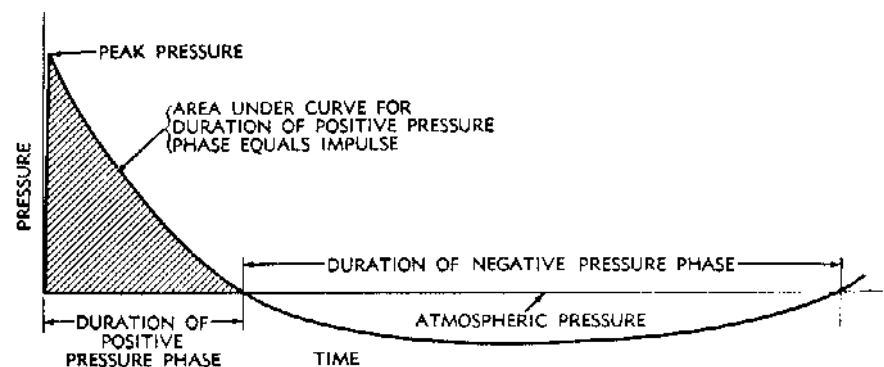

Figure 25. Pressure-Time Relationship of Explosive Blast

If many reflective surfaces are available, the resulting blast damage can be considerably greater than that without reflective surfaces. The interior of a structure or vehicle offers many such reflective surfaces. Consequently, the damage produced by exploding a blast charge inside an enclosure is considerably greater than that outside of it. Less than 20% of an explosive may be required for an interior blast kill compared with an exterior one.

Most ammunition is limited in size for tactical reasons. Artillery projectiles, for example, have a volume limitation. Hence, the designer must look for the blast explosive which produces the highest blast damage for a given volume. The missile warhead designer faces a weight limitation in the same manner.

### 32. Fragmentation

*a. Fragmentation Characteristics.* As a manifestation of explosive output, fragmentation is characterized by velocity and size distribution of fragments. For some purposes, the size and shape of fragments are predetermined either by preforming or by modifications of the case or charge design which predisposes it to break as desired. Many studies have been carried out both for fragmentation projectiles<sup>23</sup> and for specialized fragmentation warheads.<sup>24</sup>

The initial velocity of fragments is quite accurately predicted by the Gurney formulas

$$\text{for cylinders } v_0 = \sqrt{2E} \sqrt{\frac{W_c/W_m}{1 + 0.5 W_c/W_m}} \quad (25)$$

$$\text{for spheres } v_0 = \sqrt{2E} \sqrt{\frac{W_c/W_m}{1 + 0.6 W_c/W_m}} \quad (26)$$

where  $v_0$  is the initial fragment velocity

$\sqrt{2E}$  is the Gurney constant

$W_c$  is the charge weight

$W_m$  is the weight of the fragmenting metal

The empirical constant  $E$  is determined for a particular range of explosive to metal ratios. It is expressed as the quantity of energy per unit mass of explosive which is available as kinetic energy of the fragments. In general, this is somewhat more than half of the energy of detonation. Rather than reducing the quantities to theoretical terms, Gurney constants are usually given as velocities. Table 19 includes Gurney constants for some explosives of military interest. Initial fragment velocities have been computed and are available in tabular form.<sup>25</sup>

TABLE 19. GURNEY CONSTANTS FOR COMMON EXPLOSIVES

<i>Explosive</i>	$\sqrt{2E}$ (ft/sec)
Composition B	8800
Pentolite	8400
TNT	7600

The lethality of a fragment is a function of its velocity, weight and presented area. The problems of assessing lethality and vulnerability are quite difficult because the seriousness of the damage inflicted depends first on the nature of the target and then on the point of impact and direction of the flight of the fragments with respect to the target as well as its size, velocity, shape, attitude and materials.

The determination of the optimum fragment size, in addition to the lethality considerations, requires an estimate of the probable location of the fragmenting charge with respect to the target at the time of burst and a knowledge of the azimuthal distribution of the fragments. In some instances relative movement of the charge and target is an important factor. The position of the charge with respect to the target is sometimes a design variable which is combined with other factors to maximize effectiveness. For example, in an air-burst anti-personnel weapon, burst height, fragment size and azimuthal distribution are combined to maximize the lethality.

When a projectile or other container is burst by the explosion of the explosive contained, the sizes of the fragments produced vary according to a statistical distribution. Of course, this size is also affected by the charge-to-case mass ratio and by the physical properties of the case material. Where all aspects of the design of a fragmentation round or head may be varied to optimize a design, the choice of explosive is simplified by this general tendency for explosives which produce the fastest fragments to also produce the finest fragments. The explosive with the highest Gurney constant may thus be expected to be capable of producing the largest number of lethal fragments.

Where a case originally designed for anti-personnel use is to be adapted for use against more resistant targets, high performance explosives may break it into fragments too small for effectiveness. In such situations a less brisant explosive may improve effectiveness. Generally, in gun projected missiles such considerations as structural strength to resist setback and spin accelerations dictate the use of a case which forms coarser fragments than is desirable even with the most brisant explosive.

*b. Controlled Fragmentation.* Since the breakup of charge cases under explosive attack is mainly two dimensional, the average size of fragments may be reduced and their number increased by the use of multiple walled cases. A wide variety of other methods have been used to produce fragments which are almost all of the optimum size and shape. Methods which have been used include<sup>23</sup>

- (a) preformed fragments (with or without matrix)
- (b) notched or grooved rings
- (c) notched or grooved wire
- (d) notched or grooved casings
- (e) fluted liners.

One form of preformed fragment is a rod. In controlled experiments, a rod has been found to be more effective against aircraft than the same weight of metal broken into smaller pieces. It can sever important structural members rather than merely perforate them.

A discrete rod warhead consists of a number of rods (usually of steel) arranged like the staves of a barrel to form a cylindrical container. They are joined together with sufficient strength to provide the needed structural strength for handling, launching, and flight but in such a manner that their movement under the action of the explosive will not be impeded significantly. This container, completed with suitable end plates and usually with auxiliary thin liners, is loaded with the explosive.

A continuous rod warhead differs from a discrete rod warhead in that the rods are strongly joined to one another at alternate ends in a pattern similar to that of a folded carpenters' rule. This hoop breaks when its circumference equals the sum of the rod lengths, if excess energy is imparted by the explosive.

The value of a discrete rod fragment depends upon maintenance of its shape (as a relatively straight rod) and its attitude such that its long axis is at right angles to its path. The value of a continuous rod depends upon its retaining its integrity as such. Each of these requirements, in turn, rests on a basic requirement that the velocity imparted to each element of the length of the rod is the same as that for each other element. This is the most important application of the momentum distribution control discussed in Paragraph 30. The losses of pressure at the ends cause the parts of the rods near the ends of the warhead to lag behind those near the midsection. Discrete rods are bent and twisted, and continuous rods are broken as a result of the differences in velocity.

### 33. Other Output Effects

*a. Underwater.* The effects of an underwater explosion are separable into two distinct phenomena, the shock wave and the pulsation of the bubble. It is of interest to note that seventy to eighty percent of the heat of detonation can be accounted for in the sum of the energy of the shock wave and that of the movement of the bubble. The shock wave is characterized in terms of its peak pressure, energy, impulse and time constant. These quantities may be computed as functions of distance and charge weight from existing nomographs.<sup>24</sup>

The pulsation and other movements of the bubble impart large quantities of momentum to surrounding water. Under some circumstances, the migration of the bubble due to hydrodynamic and gravitational effects can result in highly concentrated transfer of this momentum to ships or other structures so that the bubble action can outweigh that of the shock wave in its damaging effects. Bubble parameters may also be calculated conveniently with a nomogram. The behavior and actions of bubbles resulting from underwater explosions has been the subject of several studies.<sup>25</sup>

*b. Underground.* The effects of underground explosion are more difficult to characterize quantitatively than are those in air or water because soils and rocks are so much more variable in character and because disturbances are transmitted through them as stress waves with components of shear and sometimes tension in addition to the pressure which characterizes waves produced by explosions in fluids. The initial wave transmitted from an explosive charge to almost any solid medium is a true shock wave and the pressures are far beyond the elastic limit. However, such shocks attenuate much faster than those in water because a large fraction of the energy is expended in shattering the medium. As the pressure approaches the compressive strength of the material, the shock is modified to a stress wave. It loses the sharp rise characteristic of a shock and may separate into several waves, elastic compression wave, plastic wave, surface wave and a shear wave, which propagate at different velocities.

Meanwhile, since soil and rock are usually variable in structure and density, waves are refracted and reflected in paths of various lengths. In addition, where the explosion occurs close enough to the surface to produce an air blast wave, this induces another surface wave. As a result of this wave, at a distance of a mile, the ground dis-



turbance from a single explosion might continue for thirty seconds. At large distances, the disturbances induced by underground explosions have essentially the same characteristics as seismic waves produced by earthquakes. However, at shorter distances, the positive durations of stress waves are similar in magnitude to the exponential decay constants for underwater explosions of charges of similar size.<sup>28</sup>

In addition to inducing shock, stress, and seismic waves, underground explosions displace the surrounding media. When close to the surface, they produce craters. Explosions too deep to burst through the surface produce spherical cavities known as camoufflets. The product of the volume of a camoufflet and the strength of the surrounding medium has been related to the heat of explosion of the charge which produces it.

*c. Shaped Charge.* The lined shaped charge is one of the most effective means for the defeat of armor in terms of the ratio of thickness penetrated to diameter of round. Much information is available on the design of shaped charges.<sup>23,29</sup> Action of the shaped charge is sometimes referred to as the Munroe effect. Operation is as follows. The metal of the liner and the explosive moves at the detonation velocity. At the detonation front, the metal liner is deflected inward. Converging symmetrically toward the centerline, the metal is deflected along this line. The slug of metal which accumulates at the center is squeezed by the continuing convergence to such high pressures that part of it emerges in a jet, like toothpaste from a tube.

Because the theory of shaped charges is based on a number of simplifying assumptions and because of unavoidable variations introduced during manufacture and loading, a large part of design

and development of shaped charges has been empirical. The following rules of thumb on the design of shaped charges, are consistent with the theory although they might not be quantitatively predictable.

(a) The optimum cone (included) angle, for most purposes, is about 42°.

(b) Maximum penetration is obtained with a stand-off distance between charge and target of 2 to 6 calibers.

(c) The cone liner material which seems to have the best combination of properties is soft copper, although mild steel and aluminum have been used to advantage.

(d) Optimum cone liner thickness is about 0.03 caliber for copper.

(e) Detonation pressure seems to be the most important property of an explosive affecting shaped charge performance.

(f) In spin stabilized rounds, the centrifugal forces are sufficient to impair shaped charge performance significantly. This may be counter-balanced, at least to some extent, by use of fluted and trumpet shaped liners.

(g) As the cone angle becomes larger, the velocity of the jet decreases and that of the slug increases. Shallow shaped charges in which the slug is the effective output are referred to as Mischay-Schardin charges. They are used extensively in land mines.

(h) As the cone angle becomes smaller the velocity of the jet becomes higher and its mass becomes smaller until, for a tube, they approach infinity and zero respectively.

(i) Although penetrations by shaped charges in armor plate as high as 11 calibers have been observed in the laboratory, the limit for practical ammunition is closer to four or five cone diameters.

# REFERENCES

## CHAPTER 3

*a-i Lettered references are listed in Paragraph 12 (end of Chapter 1).*

1. M. A. Cook, D. H. Pack, and W. A. Gey, "Deflagration to Detonation Transition in Solid and Liquid Explosives," Proc. Royal Society, Series A, 246, 1245, 281 (1958).
2. N. A. Tolch, *Law of Similitude for Sympathetic Detonations*, Aberdeen Proving Ground, BRL Report 385, 17 July 1943.
3. J. Savitt, *Investigation of Sympathetic Detonation and Evaluation of Structures for Ammunition Manufacture*, Final Report, Armour Research Foundation, Contract DA-11-173-ORD-416, October 20, 1955.
4. W. M. Slie, *A Study of Output of Detonator Versus Internal Design Factors of Limited External Dimensions (U)*, Naval Ordnance Laboratory (White Oak), NAVORD Report 3593, 10 December 1953 (Confidential).
5. *Ultrasonic Inspection, Nondestructive Testing Inspection Handbook*, Quality Assurance Pamphlet AMC 715-501, Watertown Arsenal, 17 October 1960.
6. E. H. Eyster, L. C. Smith and S. R. Walton, *The Sensitivity of High Explosives to Pure Shocks*, Naval Ordnance Laboratory (White Oak), Memorandum 10336, 14 July 1949.
7. *Sensitiveness of High Explosives* (from Hercules Powder Co.) Office of Scientific Research and Development, Report OSRD 6629, March 1946.
8. L. D. Hampton, *Sensitivity and Pelleting Characteristics of Certain Desensitized RDX Mixtures (U)*, Naval Ordnance Laboratory (White Oak), NAVORD Report 4320, 25 June 1956 (Confidential).
9. S. Duck, G. W. Reynolds and L. E. Starr, *Sensitivity of Explosives to Impact (U)*, Naval Ordnance Laboratory (White Oak), NAVORD Report 4212, 1 May 1955 to 1 November 1955 (Confidential).
10. G. Svadoba, *Sensitivity of Explosives to Impact (U)*, Naval Ordnance Laboratory (White Oak), NAVORD Report 2940, 1 May 1952 to 1 July 1953 (Confidential).
11. J. N. Ayres et al., *Varicomp, A Method for Determining Detonation-Transfer Probabilities*, Naval Ordnance Laboratory (White Oak), NAVWEPS Report 7411, July 1961.
12. W. E. Dimmock, L. D. Hampton and L. E. Starr, *Investigation of the Propagation of Detonation Between Small Confined Charges (U)*, Naval Ordnance Laboratory (White Oak), NAVORD Report 2385, 1 April 1952 (Confidential).
13. J. Smith, *Some Observations of the Growth of Detonation (U)*, Naval Ordnance Laboratory (White Oak), NAVORD Report 3753, August 25, 1954 (Confidential).
14. J. Savitt, *Effect of Acceptor Confinement Upon Acceptor Sensitivity (U)*, Naval Ordnance Laboratory (White Oak), NAVORD Report 2938, 13 November 1953 (Confidential).
15. J. Savitt, *Study of Parameters Affecting Fuze Explosive Train Performance (U)*, Armour Research Foundation, Report 8, Contract DA-11-022-501-ORD-2219, February 1957 (Confidential).
16. T. Orlow, E. Piacesi and H. M. Sternbert, "A Computer Program for the Analysis of Transient Axially Symmetric Explosion and Shock Dynamics Problems," *Third Symposium on Detonation*, Office of Naval Research, Navy Dept., Report ACR-52, Vol. 1, pp. 226-240, September 26-28, 1959.
17. *Proceedings of Detonation Wave Shaping Conference (U)*, Picatinny Arsenal, California Institute of Technology, Pasadena, California, 5-7 June 1956 (Confidential).
18. M. A. Cook, *Fundamental Principles of Wave Shaping (U)*, Utah University, Report TR 52, Contract N7-ONR-45107, August 1, 1956 (Confidential).
19. Robert W. Evans and D. K. Parks, *The Development of Equations for the Prediction of Explosive Effectiveness (U)*, Denver Research Institute, Report 8, Contract DAI-23-072-501-ORD(P)-35, 15 March 1961 (AD-323 207) (Confidential).
20. S. D. Stein, *Effect of Confinement on Blast Performance of Explosives (U)*, Picatinny Arsenal Technical Report 2555, November 1958 (Confidential).
21. R. W. Heinemann, R. W. Snook and S. D. Stein, *The Effect of Casing Materials and Explosive Compositions on Blast (U)*, Picatinny Arsenal, Ammunition Group, Report DR-TR-1-60, February 1961 (Confidential).
22. *Detonation of Cased Explosive Charges Inside F-47 Aircraft Aft Structures at a Simulated Altitude of 100,000 Feet (U)*, Aberdeen Proving Ground, Firing Record P-62416, September 1956 (Confidential).
23. Engineering Design Handbook 245(c), Ammunition Series, *Design For Terminal Effects (U)* (Confidential).\*
24. Engineering Design Handbook 290(c), *Warheads, General (U)* (Confidential).\*
25. *Table of Initial Fragment Velocities Calculated from Sperrin Formulas For Various Ratios and Explosive Energies*, Naval Ordnance Test Station, NAVWEPS Report 7592, December 22, 1960.
26. E. A. Christian and E. M. Fisher, Eds., *Explosion Effects Data Sheets (U)*, Naval Ordnance Laboratory (White Oak), NAVORD Report 2986, 4 June 1955 (Confidential).
27. R. H. Cole, *Underwater Explosions*, Princeton University Press, 1948.
28. M. A. Cook, *The Science of High Explosives*, Reinhold Publishing Corp., New York, 1958, p. 83.
29. *Transactions of Symposium on Shaped Charges*, Aberdeen Proving Ground, BRL Report 985, May 22-24, 1956

\* See inside back cover for handbook designation.

## ENVIRONMENTAL RESPONSE

## 34. Military Requirements

A military item must perform as intended after years of storage under conditions which may vary from tropical to arctic and from jungle to desert. In the case of explosive materiel, the situation is aggravated first by the fact that explosives are of necessity metastable materials, and second by the irreversibility of their operation.

The range of  $-65^{\circ}\text{F}$  ( $-54^{\circ}\text{C}$ ) to  $160^{\circ}\text{F}$  ( $71^{\circ}\text{C}$ ) has been prescribed as that which explosive material must endure in storage and remain operative. The Temperature and Humidity Test, MIL-STD-304, tests over these temperatures (see Paragraph 110) and the most common hot surveillance or hot storage tests are conducted  $160^{\circ}\text{F}$ . "Accelerated aging" tests are conducted at higher temperatures although interpretation of results is subject to question. Both bulk explosives and loaded items are subjected to hot storage, surveillance or accelerated aging tests. After aging, materials may be weighed and analyzed to detect chemical decomposition or tested to determine changes in performance characteristics. Loaded items are sometimes dissected and their various components examined and analyzed. More often, they are tested functionally. Changes in functional characteristics may result from chemical deterioration of explosive or inert components, changes in state of aggregation (such as fusion and reconsolidation, sintering or redistribution of components of mixtures) or dimensional distortion.

In the course of their use, some explosive materiel is exposed to temperatures substantially higher than  $160^{\circ}\text{F}$ . Three common sources of such high temperatures are hot guns, heat transferred through metal parts from rocket motors and aerodynamic heating. The hot gun problem, for the present, is somewhat simplified for the explosive charge designer because it is not difficult to find high explosives which are more temperature resistant than the propellants used in guns. Rocket

propellants have flame temperatures far beyond that which any explosive can sustain so that the designer of rocket warheads must consider the heat transfer situation. As missiles are projected at higher velocities for longer times, the aerodynamic heating problem becomes more severe. At these higher temperatures, all effects are exaggerated and accelerated to a point where the deteriorations, which may take months or years in storage, may occur in minutes or seconds and the thermal decomposition of the explosive may become self sustaining and run away to a thermal explosion. Such explosions are referred to as *cook-off*. In addition, the higher temperatures may cause damage of types which would never occur at lower temperatures.

In addition to temperature, explosives are subjected to other environments. One of these is the proximity with metals and other explosives which may be chemically incompatible.

In the course of military transportation, handling and use, explosives and explosive charges are necessarily subjected to rather violent mechanical disturbances. From the viewpoint of analytical mechanics, the manifestations of these disturbances are compression, tension and shear of the explosive which must be specified in time-dependent terms. However, problems associated with such disturbances are not usually considered in such terms. The usual approach is that of attempting to simulate conditions which may be experienced by explosive charges in service under quantitatively controlled conditions and in circumstances where behavior can be observed. Considered in these terms, the disturbances to which explosives may be subjected can be categorized as impact, acceleration, vibration and friction.

The relative sensitivities of common military explosives according to standard laboratory tests are given in Table 20 while sensitivities to hazards of use are tabulated in Table 21. For details of test procedures, see Paragraph 107.

TABLE 20. RELATIVE SENSITIVITIES OF EXPLOSIVES ACCORDING TO STANDARD LABORATORY TESTS OF GROUND SAMPLES

Explosive	Impact Tests			Friction Tests		Bu Mines Static Elec. Tests <sup>b</sup>		Explosion Temperature-5 sec. (°C)	Min. Det. Chg. Lead Azide (gm)	50% Det. Sensitivity, 100-gm Tetryl Booster		
	Picatinny Arsenal (in.) <sup>a</sup>	NOZ (ERL type 12) (cm)	Bureau of Mines (cm)	Picatinny† (Street Shoe)	Hercules (4kg added)	(Unconf.) (Joule)	(Confined) (Joule)			Wax Gap (in.)	Density (gm/cc)	Vacuum Stab. 40 hr. 120°C (cc)
Amatol, 50/50	16(17)	—	95	U	—	—	—	265 <sup>d</sup>	0.20	0.60	1.55	1.0
Baratol	11(24)	—	35	—	—	—	—	385 <sup>d</sup>	0.20	0.32	2.55	—
Black Powder	16(16)	—	32	S	—	>12.5	0.8	427 <sup>e</sup>	—	—	—	—
Composition A-3	16(17)	78 <sup>h</sup>	—	U	—	—	—	250 <sup>d</sup>	0.25	1.70	1.62	0.6
Composition B	14(19)	57 <sup>h</sup>	—	U	38	—	—	278 <sup>d</sup>	0.20	1.40	1.69	0.9
Composition C-3	14(33)	—	—	U	—	—	—	280 <sup>d</sup>	0.20	1.36	1.62	1.21 <sup>f</sup>
Composition C-4	19(27)	47 <sup>h</sup>	—	U	—	—	—	290	0.20	—	—	0.26 <sup>f</sup>
Cyclonite (RDX)	8(18)	24 <sup>g</sup>	100 <sup>g</sup>	E	25	—	—	260 <sup>d</sup>	0.05	—	—	0.9
Cyclotol, 70/30	14(20)	—	75	U	—	—	—	265 <sup>d</sup>	0.20	—	—	0.86
Cyclotol, 60/40	14(19)	—	100 <sup>g</sup>	U	—	—	—	280 <sup>d</sup>	0.20	—	—	0.29
Explosive D (Ammonium Picrate)	17(18)	214 <sup>h</sup>	100 <sup>g</sup>	U	—	0.025	6.0	318 <sup>d</sup>	0.20	1.27	1.54	0.4
Haleite (EDNA)	14(17)	31 <sup>h</sup>	32	U	27	—	—	189 <sup>d</sup>	0.13	2.09	1.42	1.5
beta-HMX	9(23)	26 <sup>h</sup>	60	E	—	—	—	327	0.30	—	—	0.45
Lead Azide (pure)	3(30)	—	75	E	—	0.007	0.007	340	—	—	—	—
Lead Styphnate	8(22)	12 <sup>f</sup>	—	E	—	0.0009	0.0009	282	0.001	—	—	0.3
Nitroguanidine	26(7)	320 <sup>h</sup>	48	—	—	—	—	275 <sup>d</sup>	0.20	0.67	1.41	0.44
Pentolite, 50/50	12(15)	38 <sup>h</sup>	34	U	19	—	—	220 <sup>d</sup>	0.13	2.08	1.65	3.0 <sup>f</sup>
PETN	6(16)	12 <sup>c</sup>	—	C	11	0.06	0.21	225 <sup>d</sup>	0.03	3 gm	1.6	0.5 <sup>e</sup>
Picratol, 52/48	17(19)	—	17	U	—	—	—	285 <sup>d</sup>	0.20	1.00	1.63	0.68
Picric Acid	13(17)	63 <sup>h</sup>	100 <sup>g</sup>	—	—	—	—	320 <sup>d</sup>	0.24	2 gm	1.7	0.5
Tetryl	8(18)	34-53 <sup>h</sup>	26	C	26	0.007	0.44	257 <sup>d</sup>	0.10	2.01	1.58	1.0
Tetrytol, 70/30	11(18)	—	28	U	—	—	—	320 <sup>d</sup>	0.22	1.66	1.66	3.2 <sup>f</sup>
TNT	14-15(17)	171 <sup>h</sup>	95 <sup>g</sup>	U	—	0.06	0.44	475 <sup>d</sup>	0.27	0.82	1.60	0.23
Torpex	9(15)	—	42	—	14	—	—	260 <sup>d</sup>	—	—	—	1.0
Tritonal, 80/20	13(16)	—	85	U	—	—	—	470 <sup>d</sup>	0.20	—	—	0.2

\* Figures in parentheses are sample weights in milligrams

<sup>a</sup> Ref. 2      <sup>g</sup> At 100°C, value at 120°C is >11

<sup>b</sup> Ref. 3      <sup>h</sup> Ref. 5

<sup>c</sup> Ref. 4      <sup>i</sup> Ref. 6

<sup>d</sup> Decomposes      <sup>j</sup> Ref. 7

<sup>e</sup> ignites

<sup>f</sup> E. Explodes; C crackles; S Snaps; U Unaffected

## A. TEMPERATURE

### 35. High Temperature Storage

*a. Chemical Decomposition.* As indicated by the Arrhenius equation (Eq. 5), explosives are decomposing all the time. An important basis for the selection of military high explosives is the slow rate of this decomposition at storage temperatures. The vacuum stability test, described in Paragraph 107, is the criterion of thermal stability which is used most frequently to predict storage life of an explosive.

Samples of TNT and tetryl, analyzed after storage for twenty years, showed no detectable chemical deterioration.<sup>1</sup> Assuming an activation

energy of 33,000 calories per mol, and 1.0 cc gas evolved in 40 hrs at 120°C as the vacuum stability of tetryl, Equation 5 extrapolates to predict less than one percent decomposition in twenty years at 160°F. Most military explosives have vacuum stabilities at least as good as tetryl. The storage characteristics of PETN, although worse than those of most military high explosives, are not so bad as to outweigh its desirable properties for certain applications.

*b. Dimensional Change.* Explosives, in general, have larger thermal coefficients of expansion than the metals in which they are usually loaded. This results in some tendency to extrude through any available openings when stored for long periods

at high temperatures. Under some circumstances, the pressure developed by this expansion is enough to bulge bulkheads or covers.

Some wave shaping systems (see Paragraph 30) involve the use of air spaces within or adjacent to explosive charges. At elevated temperatures, the gravitational forces are sufficient to induce creep at a rate such that the configuration, which is so critical in such applications, is modified within days to a point where the wave shaping effects are lost.

Materials, like Composition B and cyclotol, which contain large percentages of TNT, are particularly susceptible to such distortion because the high storage temperatures are so close to their melting points. Temperature cycling causes such materials to "grow." The growing is a permanent expansion which is caused by the opening of microscopic cracks due to thermal gradient stresses and the bridging of these cracks by fusion and refreezing of multiple component eutectics.

In general, plastic bonded explosives have better dimensional stability at high temperatures than castable materials. The dimensional stabilities of the resin binders of such materials provide reasonable clues regarding those of the mixtures.

*c. Explosive Property Change.* Some explosive properties, especially those associated with initiation and growth of detonation (see Paragraph 17-23), are determined by the state of aggregation of an explosive as much as by its composition.

Prolonged storage of an explosive at temperatures near its melting point can result in changes of structure and, in the case of mixtures, segregation of components. Where granular TNT is used in a booster or other application in which the differential in initiation sensitivity between cast and granular TNT is important, prolonged storage at 160°F results in substantial decrease in sensitivity, and has caused failures.

Similarly, a bare tetryl booster in an unlined cavity in Composition B, or other TNT base material, may be converted to tetrytol by exudation of the TNT.<sup>10</sup> The fuzing system may not be adequate for the initiation of tetrytol. A similar problem would exist if bare RDX and HMX boosters had been used.

*d. Exudation.* Usually TNT contains a group of impurities which can form very low melting multiple component eutectics. Much of the TNT used during World War I contained large enough fractions of such components that they exuded from the surfaces of charges. The exudate, which was an explosive and which could turn up in unintended places, presented a hazard. TNT made in accordance with present specifications does exude at 160°F.<sup>8</sup> Pentolite, which has an eutectic of 170°F and tetrytol, eutectic 153°F, have greater tendencies to exude. Tetrytol exudes at 149°F. Composition B, which has an eutectic at 174°F exudes slightly at 160°F.

TABLE 21. SENSITIVITY OF EXPLOSIVES TO HAZARDS OF USE

Explosive	100 kg Drop Test <sup>a</sup> 10% Firing		60mm Proj. Against Armor (ft/sec)	T7 Bomb Max Safe Drop (ft)	Setback <sup>b</sup> Critical Pressure (K psi)	Rifle Bullet Test (Approx. percentage)			
	Height (ft)	Cast Density (gm/cc)				E	P	B	U
Composition A-3	3.1	1.64 <sup>p</sup>	—	—	—	0	0	0	100
Composition B	3.1	1.65	209	—	87.5	3	13	4	80
Composition C-3	—	—	—	—	—	0	40	0	60
Composition C-4	—	—	—	—	—	0	0	20	80
Cyclonite (RDX)	—	—	—	—	—	100	—	—	—
Cyclotol, 70/30	—	—	—	—	—	30	30	0	40
Cyclotol, 60/40	—	—	—	—	—	5	55	25	15
Explosive D (Ammonium Picrate)	—	—	—	—	—	—	—	30	70
beta-HMX	—	—	—	—	—	—	—	—	—
Nitroguanidine	—	—	—	—	—	—	—	—	100
Pentolite, 50/50	1.5	1.59	170	—	—	72	20	—	8
PETN	—	—	—	—	—	100	—	—	—
Picratol, 52/48	7.1	1.50	—	10,000	—	—	—	40	60
Tetryl	2.8	1.57 <sup>p</sup>	—	—	—	13	54	10	23
Tetrytol, 70/30	—	—	—	—	—	0	55	0	45
TNT	6.5	1.54	1100	5,000	86.0	40	—	—	60
Torpex	—	—	—	—	—	20	80	—	—
Tritonal, 80/20	3.8	1.67	509 <sup>c</sup>	—	87.0	60	—	—	40

<sup>a</sup> Ref. 8

<sup>b</sup> Ref. 9

<sup>c</sup> 100-micron aluminum

<sup>p</sup> Pressed, 10,000 psi

E Exploded

P Partially Exploded

B Burned

U Unaffected

During a study designed to prevent exudation, it was found that the addition of a small amount of calcium silicate to charges containing TNT will keep exudation under satisfactory control.<sup>11</sup> While the exudation is controlled, the addition of the calcium silicate renders the explosive charge more brittle. The degree of increased hazard that this addition may cause has not yet been determined.

*e. Effects in Initiators.* The performance of initiators is determined as much by spatial configuration and the properties of inert components as by those of the explosive materials.

Bridgewires of electric initiators may be broken by the tension resulting from the thermal expansion of the plastic plugs which are often used in such items. Such failures have been observed.<sup>12</sup> In a test of a wirebridge initiator, substantially increased firing times after hot storage and temperature-humidity cycling were noted. Since the basic lead styphnate charge used is one of the most stable explosives known and is certainly well below any softening or phase transition point at 160°F, these changes in functioning time must be attributed to mechanical distortions. One such distortion, which may be visualized, is the compression of the explosive as a result of the difference in expansion coefficients of metal case and its plastic and explosive contents. When the initiator is returned to normal room temperature, the plastic and the explosive contract and a separation of bridgewire and explosive may result as shown in Fig. 26.

No systematic basis exists for the prediction or prevention of such deterioration of initiators. Hence, thorough testing in high temperature surveillance and cycling tests is indicated.

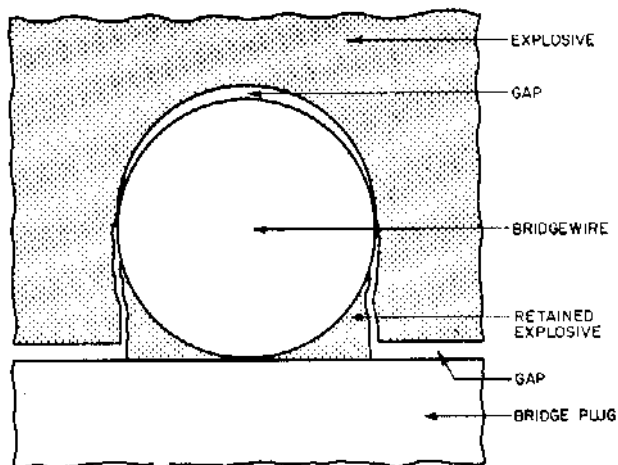

Figure 26. Postulated Condition for Initiator Failure Caused by Wire-Explosive Separation

### 36. Cook-Off

*a. Threshold Conditions.* Of all explosion processes of practical interest, cook-off is the most nearly ideal manifestation of the thermal explosion described in Paragraph 13. Considered in more general terms, it is like other initiation processes in that it is the result of a situation where energy losses cannot keep pace with the rate at which energy is released by the reaction of the explosive. When an explosive charge is exposed to a high temperature environment, its temperature rises eventually above that of the surroundings. The temperature attained in the interior of the charge is enough higher than that of the surroundings so that the heat liberated by the reaction is carried off. Since the reaction rate is an exponential function of temperature, Equation 5, a given increase in the temperature of the surroundings causes a larger than proportional increase of the temperature of the interior. A point is reached where equilibrium cannot be maintained. This temperature, referred to as the cook-off temperature, is not a constant property of an explosive but a property of a system which varies with charge size, thermal properties of surroundings and time of exposure.

For any given environmental temperature, the interior equilibrium temperature increases with the size of the charge because heat flow depends upon a temperature gradient, and even the same gradient over a longer distance should give a higher temperature (but more heat is liberated per unit area in a large charge so that the gradient is steeper). Thus, the surface temperature which will result in a thermal explosion, the cook-off temperature, decreases as the size of a charge is increased. As a general rule of thumb, cook-off temperature is decreased about 100°F for each ten-fold increase in charge diameter.

The use of thermal insulation, of course, retards the penetration of heat into an explosive charge and thus may forestall cook-off where the time of exposure is limited. However, since it also retards the dissipation of the heat evolved in the reaction, it tends to reduce the temperature which will result in eventual cook-off. Decisions regarding the use of insulation must be based on the type of exposure anticipated. The probability of cook-off is reduced by insulation of charges which are to be exposed for relatively short times to temperatures well above cook-off temperatures. Charges to be exposed to marginal temperatures for times long enough to approach thermal equilibrium are more subject to cook-off if insulated than if not.

Under usual conditions, exposure to elevated temperature is for relatively short periods. Frequently a charge is detonated purposely after exposure to high temperatures for a few minutes. Under such circumstances, the environment to which the packaged explosive charge is exposed may be well above the cook-off temperature of the charge, but the explosive may be detonated before it reaches a dangerous temperature. Figure 27<sup>19</sup>, a plot of experimental data, illustrates a case where the explosive reaches the cook-off temperature after the end of expected life. Such situations may be predicted using conventional heat transfer analysis techniques, although experimental verification is necessary. Cook-off temperatures of common military explosives are listed in Reference 14.

*b. Cook-Off Experiments.* The complications of heat flow, phase changes and reaction kinetics as applied to military explosive charges in service situations has driven many to the conclusion that the probability of cook-off can be assessed only by direct experiment. Tests using complete ammunition under service conditions is usually too expensive. Unless a charge is instrumented, such experiments can yield no more than a yes or no answer as to whether and when cook-off occurred under

the particular conditions. Instrumentation of a missile or projectile involves telemetering, adding to the expense. The compromise which has been reached most often is that of simulating the thermal conditions of use as closely as is possible in static tests using live ammunition, modified only to the extent necessary for the installation of thermocouples (see Paragraph 107).

Typical of the many cook-off experiments is one which was conducted to measure the cook-off temperature of the M47 stab detonator and to determine if this temperature could be raised by modifying its constituents. The M47, containing NOL 130 primer mix, an intermediate charge of lead azide and a base charge of RDX, when heated in an oven, cooked off at 369°F (see Table 22<sup>18</sup>). Seven additional charge combinations were tested. The highest cook-off temperature for a complete detonator (all three charges) was 415°F.

The cook-off characteristics of TNT, RDX and tetryl are plotted in Figure 28. The curves are the composites of three separate experiments which show remarkably close agreement. Data were obtained in an oven, a Wood's metal bath and in electrically heated tubing. Other experiments show that the cook-off threshold of military explosives is in the range of 350 to 450°F.<sup>19,20</sup>

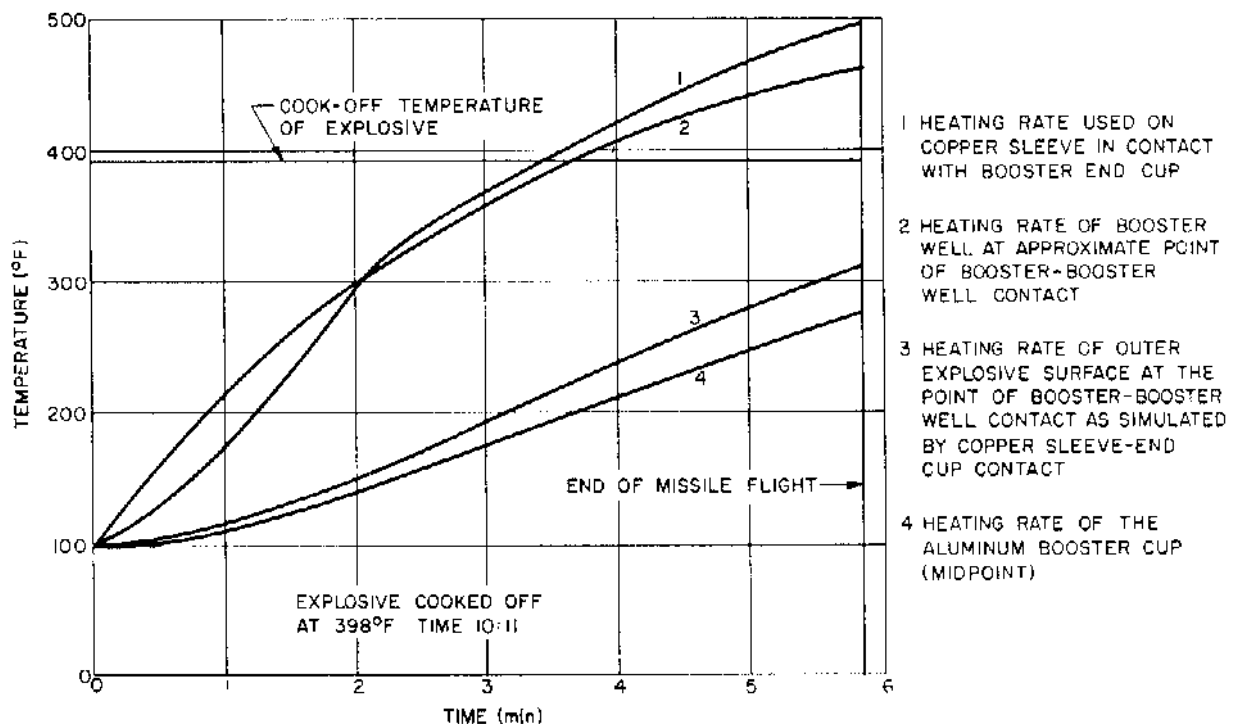

Figure 27. Test of a Booster in Simulated Missile Flight

TABLE 22. COOK-OFF TESTS OF STANDARD AND MODIFIED M47 DETONATORS

Group Designation	Upper Charge		Intermediate Charge		Base Charge		Cook-Off Temp.(°F)
	Explosive	Wt.(mg)	Explosive	Wt.(mg)	Explosive	Wt.(mg)	
Standard	NOL 130 primer mix	13	Dextrinated lead azide	105	RDX	34	369
PAX-7	Dextrinated lead azide	115	RDX	40	RDX	40	370
PAX-9	NOL 130 primer mix	13	Dextrinated lead azide	105	Inert <sup>a</sup>	40	535
PAX-8	Inert <sup>a</sup>	10	Dextrinated lead azide	105	HMX <sup>b</sup>	36	435
PAX-11	NOL 130 primer mix	13	Dextrinated lead azide	105	HMX <sup>c</sup>	34	415
PAX-12	NOL 130 primer mix	13	Dextrinated lead azide	105	HMX <sup>c</sup>	34	405
DEX	Inert <sup>a</sup>	8	Dextrinated lead azide	105	Inert <sup>d</sup>	36	520
HMX	Inert <sup>a</sup>	10	Inert <sup>d</sup>	66	HMX <sup>c</sup>	34	460

<sup>a</sup> Inert charges consisted of CP grade sodium chloride.  
<sup>b</sup> HMX, recrystallized, Lot PAE-E-23224, 2.5% RDX, max.  
<sup>c</sup> HMX, recrystallized, Lot unknown, 2.5% RDX, max.  
<sup>d</sup> HMX, laboratory recrystallized, Lot unknown, 2.5% RDX, max.

c. *Simulation of Aerodynamic Heating.* Temperature and other factors associated with aerodynamic testing are discussed in Paragraph 4. In some missile applications, the stagnation temperature, Equation 2, is well above the cook-off temperature of any known explosive, and the heating rate is limited mainly by the surface coefficient of heat transfer between air and missile. Such a situation is closely simulated by the use of a heating element of constant power in close thermal contact with the container of a charge. Data obtained in such an experiment with the apparatus shown in Figure 29<sup>15</sup> are given in Figure 30.<sup>15</sup>

37. Other Effects of High Temperature Use

a. *Melting of Explosives.* The fact that an explosive charge reaches its target before cooking off is no guarantee that it is in the same condition as that in which it was launched. All of the effects of high temperature storage are exaggerated and accelerated at the higher temperatures which sometimes result from aerodynamic heating, etc. In addition, some effects which are negligible or nonexistent at 160°F may become important at higher temperatures.

The castable explosives in common military use are all based on TNT as a vehicle. TNT melts at 178°F but most of the commonly used mixtures melt at slightly lower temperatures. One effect of the melting of TNT is the "thermal buffering" which prevents the temperature from rising above the melting point until it is completely melted. This effect may keep a tetryl booster, surrounded by TNT or a TNT mixture well below its cook-off temperature until a weapon reaches its target.

Most effects of melting are somewhat less beneficial. Wave shaping systems, which depend upon accurate retention of charge configuration, may lose all of their effectiveness with relatively

slight distortion. The segregation of the components of mixtures such as HBX can result in serious changes in explosive properties. A region in which the RDX concentration is much higher may be appreciably more sensitive than the original mixture. A hazard associated with the melting of explosives is the possibility that the material will work its way into unintended locations.

In considering the effects of charge melting in use, a certain amount of common sense is necessary. A warhead full of molten explosive may be intolerable but a little melting at the corners might have no ill effect in some applications. Estimates of the quantity or degree of melting and the location at which it is anticipated should be considered in terms of their consequences.

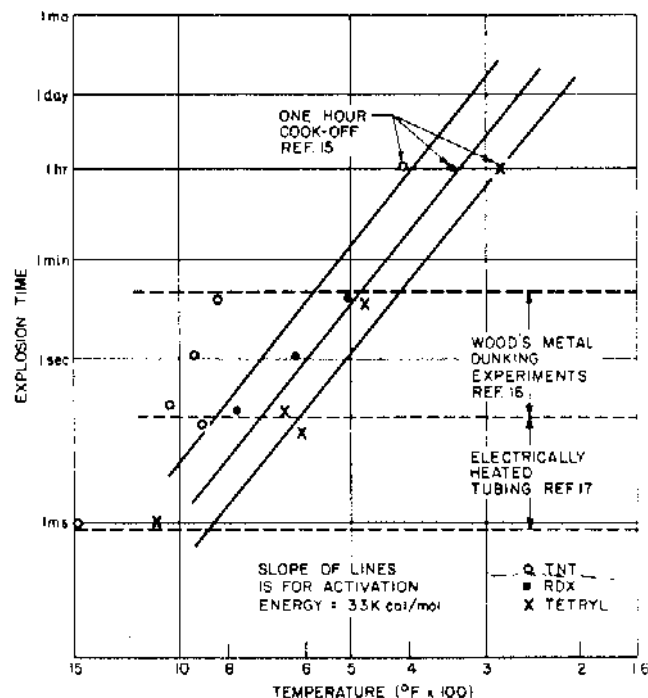

Figure 28. Cook-Off Characteristics of Three Explosives



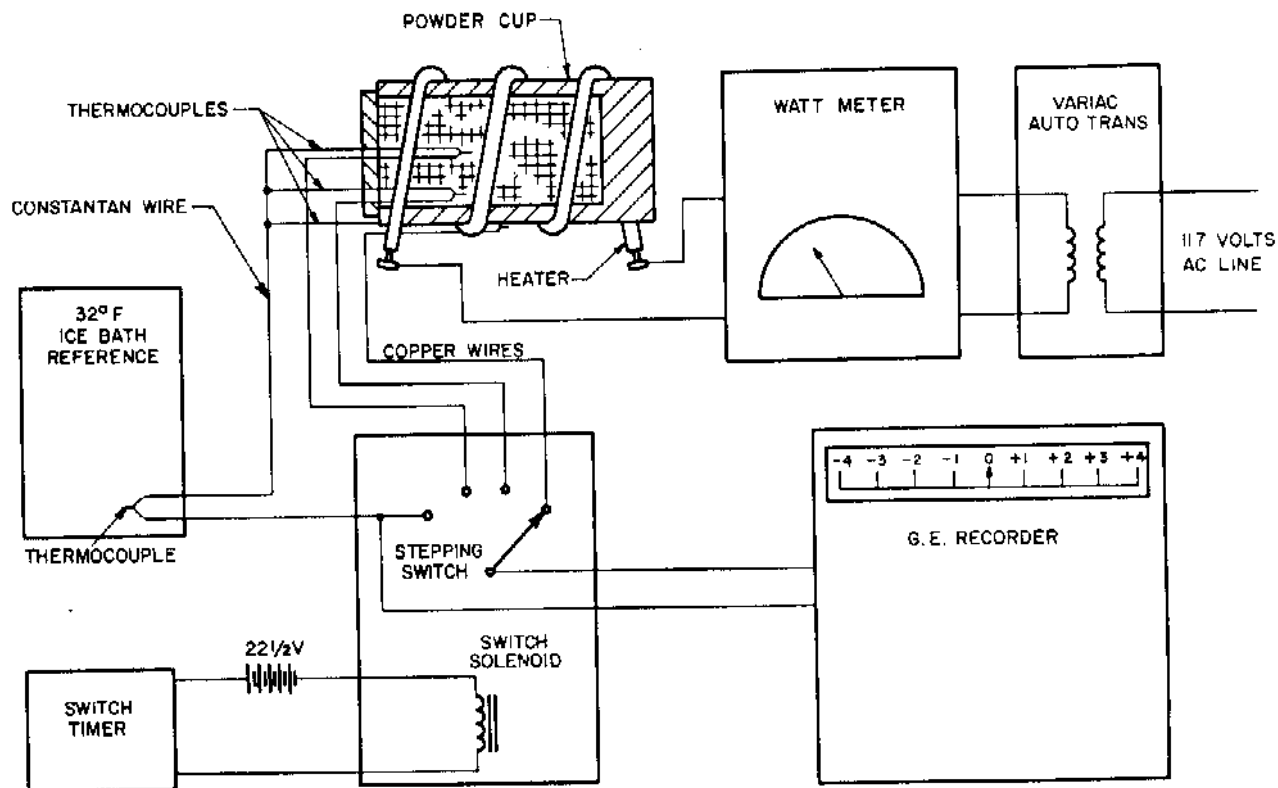

Figure 29. Apparatus for Simulating Aerodynamic Heating

*b. Sensitization.* As pointed out in Paragraph 21, the initiation process is usually thermal. With increasing temperature, less additional temperature rise is needed to induce a self propagating reaction. In other words, explosives tend to become more sensitive as they are heated. However, the effect is rather small until the cook-off temperature is approached.

Another effect is that of solid-solid phase transitions. An example of one explosive in common use is HMX which exhibits a marked change in sensitivity attributable to this cause.<sup>15</sup> However, because most missiles are on their way to their targets before they are subjected to aerodynamic heating, this type of sensitization may be of more importance in reducing effectiveness due to deflagration on impact and similar defective operation than in contributing to the hazards of use. It might contribute to the hazards associated with the hangfires in hot guns and externally mounted weapons on fast aircraft.

### 38. Low Temperature Storage and Use

Most deteriorative processes are slowed at low temperatures. Hence, low temperature storage is

usually less harmful than storage at normal atmospheric or elevated temperature. Rapid heating after low temperature storage can induce thermal stresses which may have more than usual tendencies to crack some sealing materials which become brittle at low temperatures. Ammunition which depends upon organic seals to protect moisture sensitive materials should be subjected to the temperature-humidity test (see Paragraph 110).

Burning, and the initiation, growth and propagation of explosion are often retarded or prevented by very low temperatures.

The effect of low temperatures upon the sensitivities of initiators is usually quite small because the change from room temperature is only a fraction of the rise associated with initiation. However, systems which are marginal with respect to growth or propagation of explosive reaction will usually fail in the low temperature test.

Interestingly enough, the most noticeable effect of low temperature upon stable detonation results from the shrinkage in volume. Because of the higher density at low temperatures, detonation velocities and consequently detonation pressures are higher. The increases, of course, are too small to have practical significance. Where propagation

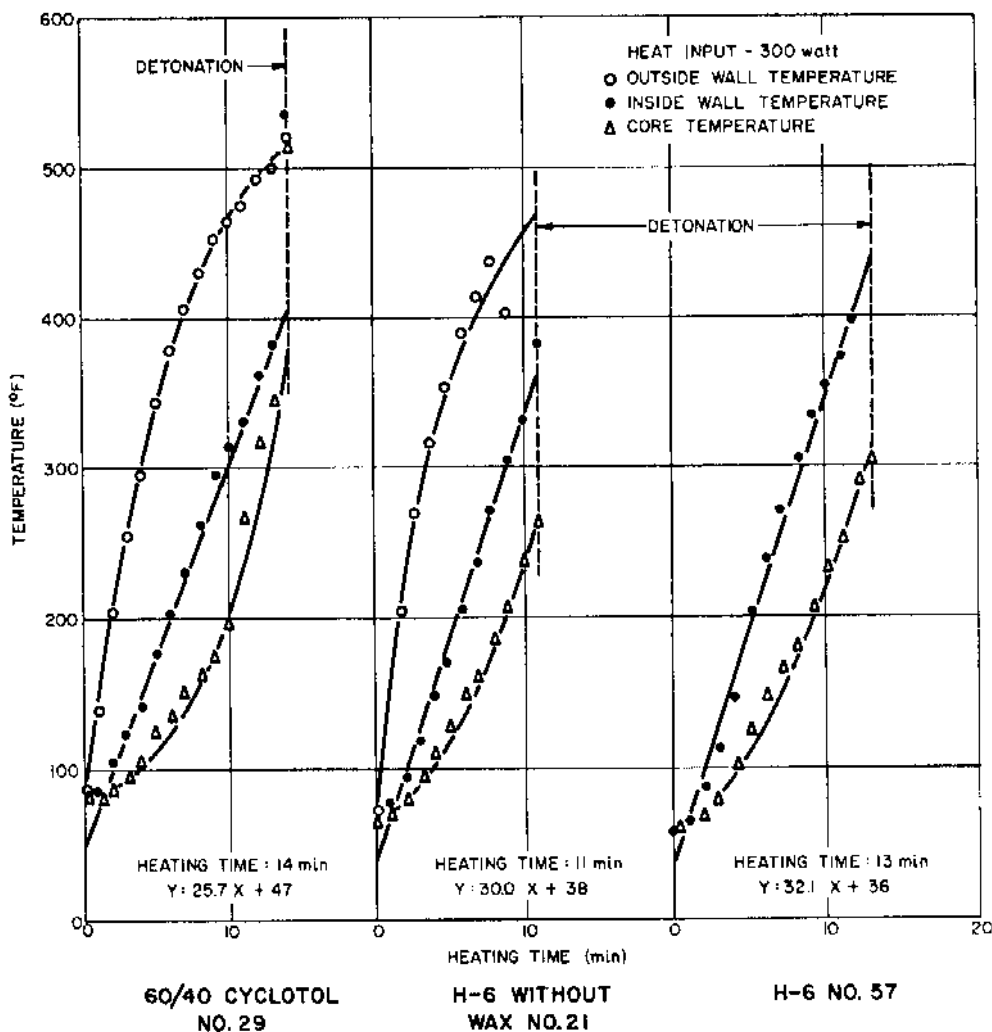

Figure 30. Simulated Aerodynamic Heat Test

time is critical and must be synchronized with a process which is independent of temperature, this effect, now accentuated by reduction in distance, can be a source of difficulty.<sup>21</sup>

## B. ENVIRONMENT

### 39. Chemical Interactions

Table 23<sup>22</sup> gives the compatibilities of explosives with common metals used in military construction and with a few other materials. More complete data regarding reactions of explosives with metals have been compiled in several studies.<sup>23,24</sup>

Of the reactions of explosives with metals, that of lead azide with copper deserves special

comment. Although this reaction is relatively slow, even in the presence of moisture, some forms of copper azide are so sensitive as to create a serious hazard even in minute quantities, particularly when in contact with lead azide. For this reason, it is desirable to utilize only containers of aluminum and stainless steel.

The compatibility of explosives with a large number of plastics has also been studied.<sup>25</sup> It was shown that the following types of plastic have negligible effect on explosives and are themselves unaffected: acrylates, cellulose, ethylenes, fluorocarbons, nylon, properly cured unmodified phenolics and silicones.

An important class of explosive materials is that of mixtures of fuels and oxidants. Oxidants are added to explosive compounds like TNT which are deficient in oxygen. Although the compounding of explosive mixtures is beyond the scope of this

TABLE 23. COMPATIBILITY OF HIGH EXPLOSIVES WITH METALS AND MISCELLANEOUS MATERIALS

Explosive	Aluminum		Brass				Magnesium				Steel												Titanium	Black paint, acidproof	Cement	Pettman											
	D	W	Brass		NRC coated		Shellac coated		D	W	D	W	D	W	D	W	D	W	D	W	D	W					D	W	D	W	D	W					
			D	W	D	W	D	W																									D	W	D	W	D
Amatol 50/50			S <sub>m</sub>	S <sub>m</sub>	VS <sub>m</sub>	VS <sub>m</sub>	VS <sub>m</sub>	F <sub>m</sub>	S <sub>m</sub> †	H <sub>m</sub> †	C <sub>m</sub>	VH <sub>m</sub>	S <sub>m</sub> †	C <sub>m</sub> †	VS <sub>m</sub>	H <sub>m</sub>	F <sub>m</sub>	C <sub>m</sub>	H <sub>m</sub>	H <sub>m</sub>	F <sub>m</sub>	F <sub>m</sub>	VS <sub>m</sub>	F <sub>m</sub>													
Composition C-3	F <sub>m</sub>	F <sub>m</sub>	VS <sub>m</sub>	VS <sub>m</sub>								F <sub>m</sub>		VS <sub>m</sub>																							
Mercury fulminate	F <sub>m</sub>	F <sub>m</sub>	F <sub>m</sub>	F <sub>m</sub>	F <sub>m</sub>	F <sub>m</sub>	F <sub>m</sub>	F <sub>m</sub>				H <sub>m</sub>	F <sub>m</sub>	F <sub>m</sub> †	F <sub>m</sub> †	F <sub>m</sub>	F <sub>m</sub>	F <sub>m</sub>	F <sub>m</sub>	F <sub>m</sub>	F <sub>m</sub>	F <sub>m</sub>	F <sub>m</sub>	F <sub>m</sub>	F <sub>m</sub>	F <sub>m</sub>	F <sub>m</sub>	F <sub>m</sub>	F <sub>m</sub>	F <sub>m</sub>	F <sub>m</sub>	F <sub>m</sub>	F <sub>m</sub>	F <sub>m</sub>	F <sub>m</sub>	F <sub>m</sub>	
Pentolite	F <sub>m</sub>	F <sub>m</sub>	F <sub>m</sub>	VS <sub>m</sub>					F <sub>m</sub> †	S <sub>m</sub> †	F <sub>m</sub>	F <sub>m</sub>	F <sub>m</sub>	F <sub>m</sub>	F <sub>m</sub>	VS <sub>m</sub>																					M
Picric acid	F <sub>m</sub>	F <sub>m</sub>	F <sub>m</sub>	F <sub>m</sub>	F <sub>m</sub>	S <sub>m</sub>	F <sub>m</sub>	F <sub>m</sub>				F <sub>m</sub>	F <sub>m</sub>	F <sub>m</sub>	F <sub>m</sub>	F <sub>m</sub>	F <sub>m</sub>	F <sub>m</sub>	F <sub>m</sub>	F <sub>m</sub>	F <sub>m</sub>	F <sub>m</sub>	F <sub>m</sub>	F <sub>m</sub>	F <sub>m</sub>	F <sub>m</sub>	F <sub>m</sub>	F <sub>m</sub>	F <sub>m</sub>	F <sub>m</sub>	F <sub>m</sub>	F <sub>m</sub>	F <sub>m</sub>	F <sub>m</sub>	F <sub>m</sub>		
Tetrytol 65/35									F <sub>m</sub>	F <sub>m</sub>																										H <sub>m</sub>	
Tetrytol 75/25	F <sub>m</sub>	F <sub>m</sub>	F <sub>m</sub>	VS <sub>m</sub>					F <sub>m</sub> †	S <sub>m</sub> †	F <sub>m</sub>	VS <sub>m</sub>	F <sub>m</sub>	VS <sub>m</sub>	F <sub>m</sub>	VS <sub>m</sub>																				H <sub>m</sub>	
Black powder	H <sub>m</sub>	H <sub>m</sub>	VH <sub>m</sub>	H <sub>m</sub>	F <sub>m</sub>	F <sub>m</sub>	F <sub>m</sub>	F <sub>m</sub>	F <sub>m</sub> †	F <sub>m</sub> †	H <sub>m</sub>	H <sub>m</sub>	F <sub>m</sub> †	F <sub>m</sub> †	VH <sub>m</sub>	VH <sub>m</sub>	F <sub>m</sub>	S <sub>m</sub>	F <sub>m</sub>	F <sub>m</sub>	F <sub>m</sub>	F <sub>m</sub>	F <sub>m</sub>	F <sub>m</sub>	F <sub>m</sub>	F <sub>m</sub>	F <sub>m</sub>	F <sub>m</sub>	F <sub>m</sub>	F <sub>m</sub>	F <sub>m</sub>	F <sub>m</sub>	F <sub>m</sub>	F <sub>m</sub>	F <sub>m</sub>		
Composition A-3	F <sub>m</sub>	F <sub>m</sub>	VS <sub>m</sub>	S <sub>m</sub>					VS <sub>m</sub>	VS <sub>m</sub> †	VS <sub>m</sub>	S <sub>m</sub>	VS <sub>m</sub>	F <sub>m</sub>	F <sub>m</sub>	S <sub>m</sub>																					
Composition B	F <sub>m</sub>	F <sub>m</sub>	VS <sub>m</sub>	S <sub>m</sub>					F <sub>m</sub> †	S <sub>m</sub> †	F <sub>m</sub>	VS <sub>m</sub>	F <sub>m</sub>	VS <sub>m</sub>	F <sub>m</sub>	VS <sub>m</sub>																				M-100 U-120 M-90	
Explosive D																																					
Lead azide	F <sub>m</sub>	F <sub>m</sub>	F <sub>m</sub>	F <sub>m</sub>	F <sub>m</sub>	F <sub>m</sub>	F <sub>m</sub>	F <sub>m</sub>				F <sub>m</sub>	C <sub>m</sub>	F <sub>m</sub> †	F <sub>m</sub> †	S <sub>m</sub>	VS <sub>m</sub>	F <sub>m</sub>	F <sub>m</sub>	F <sub>m</sub>	F <sub>m</sub>	F <sub>m</sub>	F <sub>m</sub>	F <sub>m</sub>	F <sub>m</sub>	F <sub>m</sub>	F <sub>m</sub>	F <sub>m</sub>	F <sub>m</sub>	F <sub>m</sub>	F <sub>m</sub>	F <sub>m</sub>	F <sub>m</sub>	F <sub>m</sub>	F <sub>m</sub>		
PETN	F <sub>m</sub>	VS <sub>m</sub>	F <sub>m</sub>	VS <sub>m</sub>					F <sub>m</sub> †	S <sub>m</sub> †	F <sub>m</sub>	VS <sub>m</sub>	F <sub>m</sub>	VS <sub>m</sub>	F <sub>m</sub>	F <sub>m</sub>																					
Picratol 52/48																																					
RDX	F <sub>m</sub>	F <sub>m</sub>	F <sub>m</sub>	F <sub>m</sub>	F <sub>m</sub>	F <sub>m</sub>	F <sub>m</sub>	F <sub>m</sub>				F <sub>m</sub>	F <sub>m</sub>	F <sub>m</sub> †	F <sub>m</sub> †	S <sub>m</sub>	VS <sub>m</sub>	F <sub>m</sub>	F <sub>m</sub>	F <sub>m</sub>	F <sub>m</sub>	F <sub>m</sub>	F <sub>m</sub>	F <sub>m</sub>	F <sub>m</sub>	F <sub>m</sub>	F <sub>m</sub>	F <sub>m</sub>	F <sub>m</sub>	F <sub>m</sub>	F <sub>m</sub>	F <sub>m</sub>	F <sub>m</sub>	F <sub>m</sub>	F <sub>m</sub>	F	
Tetracene	F <sub>m</sub>																																				
Tetryl	F <sub>m</sub>	F <sub>m</sub>	VS <sub>m</sub>	F <sub>m</sub>	F <sub>m</sub>	F <sub>m</sub>	F <sub>m</sub>	F <sub>m</sub>			H <sub>m</sub>	C <sub>m</sub>	F <sub>m</sub> †	F <sub>m</sub> †	F <sub>m</sub>	F <sub>m</sub>	F <sub>m</sub>	F <sub>m</sub>	F <sub>m</sub>	F <sub>m</sub>	F <sub>m</sub>	F <sub>m</sub>	F <sub>m</sub>	F <sub>m</sub>	F <sub>m</sub>	F <sub>m</sub>	F <sub>m</sub>	F <sub>m</sub>	F <sub>m</sub>	F <sub>m</sub>	F <sub>m</sub>	F <sub>m</sub>	F <sub>m</sub>	F <sub>m</sub>	F <sub>m</sub>	U	
Tetrytol 70/30									F <sub>m</sub>	F <sub>m</sub>																										H <sub>m</sub>	
TNT	F <sub>m</sub>	F <sub>m</sub>	F <sub>m</sub>	F <sub>m</sub>	F <sub>m</sub>	F <sub>m</sub>	F <sub>m</sub>	F <sub>m</sub>	F <sub>m</sub> †	H <sub>m</sub> †	F <sub>m</sub>	F <sub>m</sub>	F <sub>m</sub>	F <sub>m</sub> †	VS <sub>m</sub>	VS <sub>m</sub>	VS <sub>m</sub>	F <sub>m</sub>	F <sub>m</sub>	F <sub>m</sub>	F <sub>m</sub>	F <sub>m</sub>	F <sub>m</sub>	F <sub>m</sub>	F <sub>m</sub>	F <sub>m</sub>	F <sub>m</sub>	F <sub>m</sub>	F <sub>m</sub>	F <sub>m</sub>	F <sub>m</sub>	F <sub>m</sub>	F <sub>m</sub>	F <sub>m</sub>	F <sub>m</sub>	N to M	
Tritonal 80/20																																				N to M	

† 2 months      † 10 months      † 12 months      † 18 months

Legend

- F = favorable, no visible evidence of reaction
- VS = very slight corrosion, indicated by light tarnishing
- S = slight corrosion, indicated by heavy tarnishing
- H = heavy corrosion
- VH = very heavy corrosion
- C = considerable corrosion, indicated by pitting or rusting
- P = prohibited
- N = negligible reaction
- M = moderate reaction
- U = undesirable reaction
- D = dry sample
- W = wet sample
- Subscript m = explosive reaction on metal
- Subscript x = metal reaction on explosive

handbook, a few remarks regarding the reactions of some of the oxidants may be useful as a guide to designers who specify mixtures containing them.

Many of the oxidants used are nitrates, chlorates and perchlorates. Water solutions containing these ions are highly corrosive to metals. The alkaline metal salts, with the help of a little moisture, will pit aluminum quickly. The trend away from potassium chlorate in priming mixes is part of the effort to reduce corrosion. Where explosives are used which contain metallic nitrates, chlorates or perchlorates in contact with metals, particular attention should be given the exclusion of moisture.

In delay compositions, these corrosion problems have resulted in widespread use of chromates which, in addition to being insoluble, tend to inhibit corrosion.

Mixture containing chlorates and perchlorates in combination with organic materials tend to be quite sensitive. There has been a general reluctance to use such mixtures except as primary explosives. An exception has been ammonium perchlorate.

#### 40. Simulation of Impact

*a. Laboratory Impact Tests.* The objection to the laboratory impact tests described in Paragraph 22 is that the explosive sample does not simulate those in actual use. Hence, a standard machine was adapted to the testing of pressed and cast military explosives by the use of modified tools in which one inch by one inch cylindrical pellets are cast or pressed directly.<sup>8</sup> The data are given in Table 21. Other impact tests are described in Paragraph 107.

*b. Bullet Impact.* The standard bullet impact test consists of shooting at a capped pipe nipple, loaded with the explosive to be tested, with a caliber 30 rifle bullet fired from 90 feet. The test is described in Paragraph 107 and data obtained are given in

Table 21. Some of the uncontrolled variables have been eliminated by the use of a test bomb with flat target surfaces in which both thickness of the target plates and explosive column length may be varied conveniently. Some of the effects of such variations are shown in Table 24.<sup>26</sup> Note that the sensitivity increases both with plate thickness and charge length.

In the bullet impact tests of other explosives, both aluminum and steel target plates were used in thicknesses ranging from  $\frac{1}{32}$  to  $\frac{3}{16}$  inch. Most of the explosive specimens were three inches long, but four, five, and six-inch columns were also tested. To the extent that it was significant, the effect of charge length varied with the explosive and with the criterion used to determine whether or not a charge was initiated. The general trend toward more frequent and vigorous reaction with increasing target plate thickness, as noted in Table 24 seemed to apply to most explosives tested. Initiation was also more frequent with steel plates than aluminum. These effects of plate material and thickness were referred to as confinement effects.

Another interpretation is that the heavier plates serve as more effective anvils for the initiation of the explosives by squeezing or pinching as the explosive approaches the back plate. One aspect of this interpretation, that initiation sometimes occurs as the projectile approaches the rear plate, was the subject of another investigation.<sup>27</sup>

*c. Mass Impact.* In the course of use, military explosive charges are often brought to rest from high velocities by impact. Whether the impact is intentional or accidental, it is usually undesirable for an explosion to result. Explosion due to target impact is usually deflagration, low order detonation or, if high order, it starts from the wrong place or at the wrong time. The undesirability of explosion of accidentally dropped or jettisoned charges is obvious.

TABLE 24. BULLET SENSITIVITY OF 50/50 PENTOLITE

Column Length (inch)	Plate Thickness (inch)	Avg. Chg. Density (gm/cc)	Observed Effects				
			Unaffected	Smoke	Burning	Partial Detonation	Complete Detonation
1	0.146	1.68	0	10	0	0	0
1	0.250	1.66	0	9	1	0	0
1	0.375	1.69	1	2	7	0	0
2	0.146	1.58	0	0	3	6	0
2	0.250	1.67	0	0	0	9	1
2	0.375	1.63	1	1	0	4	4
3	0.146	1.62	0	0	3	7	0
3	0.250	1.63	0	0	0	6	4
3	0.375	1.65	0	0	0	2	8

The armor plate impact test and bomb drop test, which are described in Paragraph 107 and data from which are given in Table 21, are direct tests under particular sets of service conditions. Clearly, the velocity or drop height which will result in an explosion can be expected to vary substantially with such factors as the design and striking attitude of the ammunition and the nature of the surface it strikes.

#### 41. Setback Acceleration

The setback acceleration, experienced by projectiles as they are propelled from guns, has been the subject of much research. Although this work has been specifically concerned with setback, most of the principles and basic data are equally applicable to the assessment of effects of acceleration of similar magnitude from other causes such as water entry and target or earth impact.

Table 1 lists some typical magnitudes of acceleration to which weapons are subjected in the course of their use. More specific data are usually available to the designer of components for a particular application. Effects of these accelerations on inert components may be computed by conventional applied mechanics.<sup>8</sup> Failure of mechanical components as a result of acceleration-induced stresses may, of course, result in the application of impact of sufficient magnitude to initiate an explosive charge. Some types of explosive charge, including shaped charges for example, are strongly dependent upon both configuration and point of initiation for their effectiveness. The explosive material is part of the structure which maintains such configuration.

Typical setback accelerations experienced by projectiles are of the order of 30,000 times that of gravity.<sup>24</sup> The acceleration increases from zero to its maximum value (see Figure 31) in a few milliseconds. The duration of the acceleration period is long compared to the transit time for a compression wave in the material, but short compared with the time required for significant heat transfer. Thus, the compression which results may be considered essentially adiabatic. If the explosive is considered to behave as a fluid, the pressure  $P$  at the base of the charge cavity is essentially the weight of a column of explosive of unit area, and length equal to that of the explosive charge, multiplied by the acceleration in  $g$ 's.

$$P_{(psi)} = 0.036 \rho_{(gm/ccr)} a_{(g)} L_{(in.)} \quad (27)$$

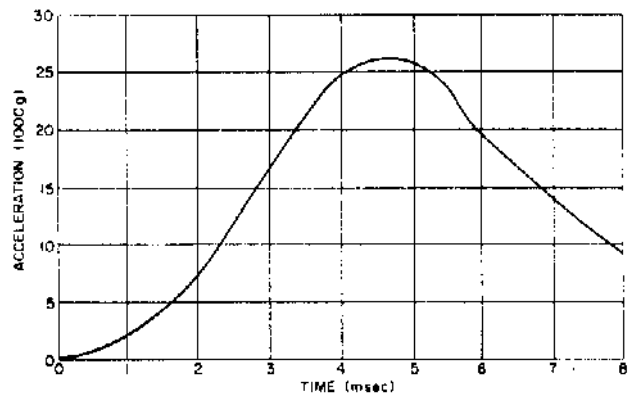

Figure 31. Typical Time-Acceleration Curve for Projectile While in Gun

In a typical projectile with an explosive charge of Composition B ( $\rho_o = 1.7$ ), ten inches long, the pressure at 30,000  $g$ 's would come to about 18,300 psi. Since this pressure is several times the 2,200 to 3,000 psi compressive strength for Composition B, the assumption of fluid behavior is quite valid.

The apparatus for the measurement of the sensitivity of explosives to initiation by rapidly rising pressure, such as that due to setback, is described in Paragraph 107. Setback sensitivity data so obtained for various explosives are listed in Table 21.

The setback initiation pressure drops linearly with increasing temperature to zero at the cook-off temperature. This increase in sensitivity with increasing temperature can raise the probability of bore prematures where projectiles are left in hot gun chambers for appreciable periods before firing.

It was found that, when separation of charge base from projectile was simulated by separation of plunger from specimen in the test apparatus, the critical setback pressures were substantially reduced (see Table 25).<sup>9</sup> This increase in sensitivity is said to be related to initiation of the explosive by the adiabatic compression of the air.

Findings that cavities such as bubbles, incidental to the casting process, and grit inclusions

TABLE 25. CRITICAL SETBACK PRESSURES OF EXPLOSIVES OF VARIOUS BASE SEPARATIONS

Explosive	No Separation	Pressure (psi)*	
		$\frac{1}{16}$ in. Separation	$\frac{1}{8}$ in. Separation
Composition B	87,500	32,000	11,200
Cyclotol 75/25	82,000†	31,500	—
TNT	86,000	37,000	19,500
Tritonal 80/20	87,000†	—	—

\* Maximum setback pressure at which explosive cannot be initiated at 125° F/in. 25 or more shots.

† Extrapolated 0% point.

can cause substantial reduction in critical setback pressures have resulted in the following suggested provisions in projectile loading standards<sup>15,29,30</sup>

(a) No cavities should be permitted at the interface of explosive charge and inside base of the projectile.

(b) No cavity should be permitted in the explosive charge close to its base.

(c) No grit should be permitted in the projectile.

(d) No projectile with deep gouges on the interior surface at the base area should be accepted.

#### 42. Other Effects

*a. Vibration.* No evidence is available which indicates that explosives as such are affected by vibration of the types to which ordnance items may be subjected. As structural materials, of course, explosives may be severely damaged by vibrations. Included in such structural damage is crumbling, after which small particles of explosive, under the influence of strong vibration, may move considerable distances and become lodged in crevices where vibrational friction or repeated impact might result in initiation. The prediction of such conditions cannot be reduced to a formula. However, for items subject to vibration, some consideration should be given the resonant properties of explosive and inert structures.

Standard tests to simulate vibrations to which materiel is subject are described in Paragraph 110.

*b. Friction.* The sensitivity of explosives to friction is well known from a qualitative point of view, but meaningful quantitative techniques for its measurement are not included in the standard explosive laboratory procedures. Some data are given in Table 20 and the test is described in Paragraph 107. Their quantitative applicability to practical problems is not clear. Situations in which explosives are subject to frictional movement should be carefully avoided in design, as well as in handling and loading practices. At least one fatal accident has been ascribed to TNT in screw threads.<sup>31</sup>

*c. Electricity.* The electrical influences to which materiel is exposed are discussed in Paragraph 7. The most serious electrical problems stem from the possibility of initiation of electric initiators by spurious signals. Paragraph 50 contains informa-

tion regarding the input characteristics of such items. Normally an electric initiator cannot discriminate between intentional and accidentally applied signals.

Static electricity can be a source of spurious signals for the initiation of electrical items and, in addition, is a hazard in the loading of explosives. Sensitivities to static electricity of powdered explosives are given in Table 20 and tests are described in Paragraph 107. Except for primary explosives, most explosives are quite insensitive to static electricity after loading. However, most pressed explosives (with the exception of plastic bonded explosive) are subject to a certain amount of crumbling and chalking at exposed surfaces. If such attrition of the surfaces is not prevented by appropriate coating or other covering, the powdered material can constitute a static hazard. Installations where initiators or bulk explosives are handled or stored should be made with conductive floors and bench tops and all personnel should be properly grounded by conductive shoes, bracelets or other means.<sup>32,33</sup>

*d. Irradiation.* Most materiel is packaged to exclude infrared, ultraviolet and visible radiation and the likelihood of any appreciable dosage of X-rays or nuclear radiation seems remote.

Primary explosives, including lead and silver azide, decompose when exposed to visible and ultraviolet light. At intensities many times higher than that of direct sunlight, a number of investigators have been able to initiate some of these substances by such radiation.<sup>34</sup> The initiation is found to be basically thermal although there is some evidence of photochemical action in some cases. Decomposition under usual daylight or artificial illumination is too slow to affect these materials in the exposure times associated with ordinary loading. However in the loading plant, exposure of lead azide to direct sunlight is avoided. Decomposition of secondary explosives by visible or ultraviolet radiation is generally too slow to detect.

Data obtained on the effects of exposure to gamma radiation at an average rate of  $10^5$  r/hr are summarized in Table 26.<sup>34</sup> Note that the effects on most materials are quite small and that the greatest effects are those on lead azide.

TABLE 26. DATA OBTAINED FROM EXPLOSIVES AFTER EXPOSURE TO GAMMA RADIATION

	<i>TNT</i>	<i>Tetryl</i>	<i>RDX</i>	<i>Lead azide</i>	<i>Lead styphnate</i>	<i>Diazodinitrophenol</i>	<i>Nitroglycerin</i>	<i>PETN</i>
	5	5	5	2	5	2	1	5
Weight of sample (g)								
Volume of gas produced (ml/g) in the following times (days)								
10	0.02	0.10	0.16	1.10	0.05	0.25	2.5	0.10
20	0.04	0.20	0.44	1.95	0.07	1.35	5.0	0.43
30	0.06	0.35	0.87	2.90	0.09	3.25	7.5	1.04
40	0.08	0.48	1.49	3.95	—	5.60	9.0	2.33
50	0.11	0.66	—	5.30	0.10	7.2	10.8	—
90	0.20	1.40	—	—	0.12	—	—	—
Total irradiation time (days)	90	90	44	52	90	45	56	42
Purity of sample, by chemical analysis (%)								
original material	—	—	—	93.08	—	—	—	—
irradiated material	—	—	—	89.04	—	—	—	—
Melting points, corrected (°C)								
original material	82.1	128.8	204.8	—	—	—	—	140.8
irradiated material	80.9	127.8	204.8	—	—	—	—	137.0
Sensitivity to impact, Picatinny Arsenal machine (in.)*								
original material	13	—	9	3	6	2	—	—
irradiated material	12	—	8	3	6	2	—	—
Sensitivity to impact, Bureau of Mines machine (cm)*								
original material	95	25	40	65	20	4	—	—
irradiated material	95	26	25	75	22	3	—	—
Sand test, 200 g bomb, grams of sand crushed when sample was ignited by black-powder fuse only								
original material	—	—	—	20.5	14.1	22.1	—	—
irradiated material	—	—	—	18.7	14.3	14.1	—	—
Sand test, 200 g bomb, grams of sand crushed when sample was initiated by 0.30 g of lead azide								
original material	48.9	56.4	61.7	—	—	—	—	—
irradiated material	50.1	56.0	62.0	—	—	—	—	—

\* Minimum height of fall of 2.0 kg weight to produce at least one explosion in ten trials.

## REFERENCES

### CHAPTER 4

*a-i Lettered references are listed in Paragraph 12 (end of Chapter 1).*

1. *Surveillance of High Explosives*, Picatinny Arsenal Technical Report 986, August 14, 1939.
2. S. Duck, G. W. Reynolds and L. E. Starr, *Sensitivity of Explosives to Impact (U)*, Naval Ordnance Laboratory (White Oak), Report NAVORD 4212, 1 May 1955 to 1 November 1955 (Confidential).
3. S. F. Duck et al., *Sensitivity of Explosives to Impact (U)*, Naval Ordnance Laboratory (White Oak), NAVORD Report 4394, 20 December 1956 (Confidential).
4. S. Svadeba, *Sensitivity of Explosives to Impact (U)*, Naval Ordnance Laboratory (White Oak), NAVORD Report 2940, 1 May 1952 to 1 July 1953 (Confidential).
5. G. Svadeba, *Impact Sensitivity of Primary Explosives (U)*, Naval Ordnance Laboratory (White Oak), NAVORD Report 2647, 1 November 1952 (Confidential).
6. J. R. Holden, *Preliminary Evaluation of Small Cast Samples for Impact Sensitivity Testing (U)*, Naval Ordnance Laboratory (White Oak), NAVORD Report 4399, 23 October 1956 (Confidential).
7. F. W. Brown, D. J. Kusler and F. C. Gibson, *Sensitivity of Explosives to Initiation by Electrostatic Discharges*, Commerce Dept., Bureau of Mines, Report RI-3852, 1946.
8. R. L. Wagner and M. E. Pollack, *Development of an Impact Sensitivity Test for Cast and Pressed Explosives*, Picatinny Arsenal Technical Report 2290, June 1956.
9. R. W. Heinemann and R. T. Schimmel, *Sensitivity of Explosives to Setback Pressure*, Picatinny Arsenal Technical Report 2572, December 1958.
10. A. J. Pascazio, *The Suitability of a Bare PBX Booster Pellet in the 2.75-Inch Head M1 Rocket Head*, Picatinny Arsenal Technical Report 2271, November 1955.
11. R. W. Heinemann and S. J. Lowell, *Prevention of Exudation from Ammunition Items*, Picatinny Arsenal Technical Report 2675, February 1960.
12. G. W. Peet and L. F. Gowen, *Evaluation Test Results on Service and Experimental Squibs*, Naval Ordnance Laboratory (White Oak), NAVORD Report 6061, 4 March 1958.
13. B. J. Meleski, *Development of Flexible Explosive Lead, Mark 11 Mod 0, and Warhead Booster Mark 36 Mod 1 (U)*, Naval Ordnance Laboratory (White Oak), NAVORD Report 6664, 30 June 1959 (Confidential).
14. R. W. Heinemann, et al., *Sensitivity of Explosives to Aerodynamic Heating (U)*, Picatinny Arsenal Technical Report 2651, October 1959 (Confidential).
15. R. McGill and P. L. Holt Eds., *Proceedings of the Gilbert B. L. Smith Memorial Conference on Explosive Sensitivity (U)*, Naval Ordnance Laboratory (White Oak), NAVORD Report 5746, 2 June 1958 (Confidential).
16. W. H. Rinkenbach and A. J. Clear, *Standard Laboratory Procedures for Sensitivity, Brisance, and Stability of Explosives*, Picatinny Arsenal Technical Report 1401, Rev. 1, February 1950.
17. *Third Symposium on Detonation*, Office of Naval Research, Navy Dept., Report ACR-52, September 26-28, 1960.
18. R. L. Wagner, *Development of a Modified M47 Detonator Having Improved Cook-Off Characteristics*, Picatinny Arsenal Technical Report 2519, June 1958.
19. R. L. Wagner and R. W. Snook, *Thermal Stability of Several Electric Detonators (U)*, Picatinny Arsenal Technical Report 2482, March 1958 (Confidential).
20. Gunther Cohn, *Cook-Off in Aircraft Guns, Summary 1952-1959*, The Franklin Institute, Report F-A2144-2, Contract DA-36-034-501-ORD-10RD, June 1960 (SPIA 20-688, AD-239 808).
21. G. V. Horvat and E. J. Murray, *Propagation of Detonation in Long Narrow Cylinders of Explosives at Ambient Temperature and at -65°F*, Picatinny Arsenal Technical Report 2389, January 1957.
22. Engineering Design Handbook 245(c), Ammunition Series, *Design for Terminal Effects (U)* (Confidential).\*
23. L. H. Eriksen, *Action of Explosives on Metals Used in Ammunition*, Picatinny Arsenal Technical Report 1493, 24 January 1945.
24. B. V. Zlotucha and M. Baer, *The Reactivity of Explosives With Metals and Protective Finishes*, Picatinny Arsenal Technical Report 2288, May 1956.
25. M. C. St. Cyr, *Compatibility of Explosives With Polymers*, Picatinny Arsenal Technical Report 2595, March 1959.
26. S. D. Stein and M. E. Pollack, *Development of an Improved Rifle Bullet Impact Sensitivity Test*, Picatinny Arsenal Technical Report 2247, May 1956.
27. R. L. Jameson and J. S. Williams, *Velocity Loss of Projectiles Passing Through High Explosives*, Aberdeen Proving Ground, BRL Memo Report 1127, October 1957.
28. Engineering Design Handbook 247(c), Ammunition Series, *Design for Projection (U)* (Confidential).\*
29. L. Jablansky, *Factors Affecting Sensitivity of Composition B to Setback*, Picatinny Arsenal Technical Report 2433, June 1957.
30. S. D. Stein, *Proposed Shell Loading Standards Based on a Statistical Study of Setback Sensitivities*, Report 63, Explosives Development Section, FREI., Picatinny Arsenal, May 1959.
31. S. D. Stein and S. J. Lowell, *Initiation of Explosive in Shell Threads*, Picatinny Arsenal Technical Report 2441, July 1957.
32. J. N. Ayres and I. Kabik, *A Study of the Effects of Static Electricity on Low Input Energy Electric Initiators of the Carbon-Bridge Type*, Naval Ordnance Laboratory (White Oak), NAVORD Report 3670, August 1954.
33. D. J. Kusler and F. W. Brown, *Ignitability of Explosives by Static Electricity*, Bureau of Mines Technical Note 31, 5 May 1944.
34. F. P. Bowden (Leader), "A Discussion on the Initiation and Growth of Explosion in Solids," Proc. Royal Society, Series A, Mathematics and Physical Sciences, 246, 1245. (1958)

\* See inside back cover for handbook designation.



## PART TWO—DESIGN CONSIDERATIONS

### 43. Introduction

Explosive materiel serves its function only if exploded at the intended time and place. The fuze is the mechanism which senses these circumstances and initiates the explosive reaction in response to the stimulus generated by target impact, proximity or some other circumstance or combination of circumstances to which the fuze is designed to respond.

The first explosive component or initiator is that explosive charge which starts the explosive reaction in response to the initiating stimulus. At the other end of the train is the main bursting charge which produces the desired effect at the target. The

intervening components establish a detonation wave, introduce the desired delay, guide the detonation through the required path and augment the detonation.

This part is concerned with each of the explosive charges which make up the explosive train. Each is described, its characteristics are specified and design procedures are given. In addition, there are presented a number of other explosive charges used as auxiliary devices, such as actuators, or the related field of demolition devices, such as destructors and explosive bolts. Finally, methods of loading and fabrication and techniques for evaluation procedures are discussed.

## CHAPTER 5

### PRIMERS AND DETONATORS

#### A. DESCRIPTION AND SELECTION

##### 44. Function and Construction

The first element of the explosive train is the initiator. It responds to the target stimulus received by the fuze and starts the explosive reaction. Initiators are classified according to the nature of the stimulus to which they are designed to respond as stab, percussion or electric and according to their output characteristics as primers, detonators or squibs.

A primer is a relatively small sensitive explosive component used as a first element in an explosive train. As such it serves as an energy transducer converting mechanical or electrical energy into explosive energy. In this respect, the primer is unique among the other explosive components in a train. A primer, which is loaded with sensitive material, has a relatively small explosive output and will not reliably initiate secondary high explosive charges. Sometimes, however, the purpose of the primer is performed for convenience by a detonator. A squib is a type of electrically initiated primer.

A detonator is a small sensitive explosive component which is capable of reliably initiating high order detonation in the next high explosive element in the explosive train. It differs from the primer in that its output will initiate reliably secondary high explosive charges. It can be initiated by nonexplosive energy, in which case it includes the action of a primer, or by the output of the primer. Furthermore, when acted upon by sufficient heat, or by mechanical or electrical energy, it will detonate.

Primers and detonators are housed in cylindrical cups of aluminum, stainless steel, copper or gilding metal. The open end is sealed with a closing disk of metal or of paper over which the end of the cup is crimped. In case of electric initiators, the cup is crimped over the plug which contains lead wires or contact pin. Primers contain an explosive priming mix while detonators contain three charges, primary, intermediate and base, although sometimes two of these are combined. The primary charge is near the input or acceptor end and the base charge is near the output end.

#### 45. Initiator Types

a. *Stab Initiators.* The stab initiator is a rather simple item consisting of a cup loaded with explosives and covered with a closing disk. It is sensitive to mechanical energy. A typical stab detonator is shown in Figure 32.

b. *Percussion Primers.* Percussion primers differ from stab initiators in that they are initiated and fired without puncturing or rupturing their containers. They are therefore used in fuzes mainly as initiators for obturated (sealed) delay elements. The essential components of a percussion primer are a cup, a thin layer of priming mix, a sealing disk and an anvil. Initiation is accomplished by a blunt firing pin which squeezes the priming mix between cup and anvil. Typical percussion primers are shown in Figure 32. In general, they are less sensitive than stab initiators (12 in-oz is a typical "all-fire" point). Percussion primer cups are constructed of ductile metals, commonly brass, in order to avoid rupture by the firing pin.

c. *Flash Detonators.* Flash detonators are essentially identical in construction to stab initiators. They are sensitive to heat. A typical flash detonator is shown in Figure 32. Flash detonators are considered to be initiators for convenience of grouping even though they are not the first element in the explosive train.

d. *Electric Initiators.* Electric primers and electric detonators differ from stab initiators in that they contain the initiation mechanism as an integral part. They constitute the fastest growing class of explosive initiators.

Several types of initiation mechanism are commonly employed in electric initiators: hot wire bridge, exploding bridgewire, film bridge, conductive mixture and spark gap. While these types, depending on specific design, may or may not provide initiators with large differences in input sensitivities, they do exhibit different electrical characteristics. Typical electric initiators are shown in Figure 33. Electrical contact is by means of two wires, by center pin and case, or occasionally by two pins.

To indicate construction, let us examine a wire lead initiator. Two lead wires are molded into a cylindrical plug, usually of bakelite, so that the ends of the wire are separated by a controlled distance on the flat end of the plug. This gap can then be bridged with a graphite film or a bridge wire.

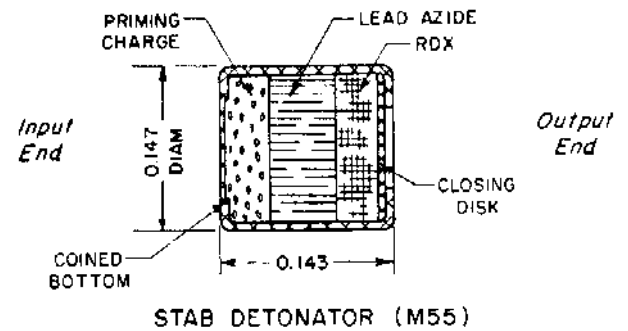

STAB DETONATOR (M55)

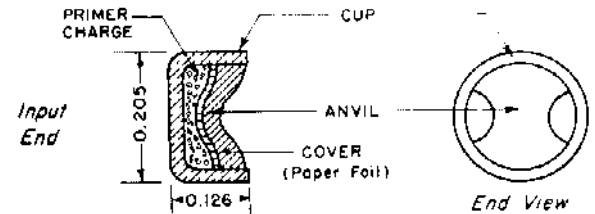

PERCUSSION PRIMER (M29A1)

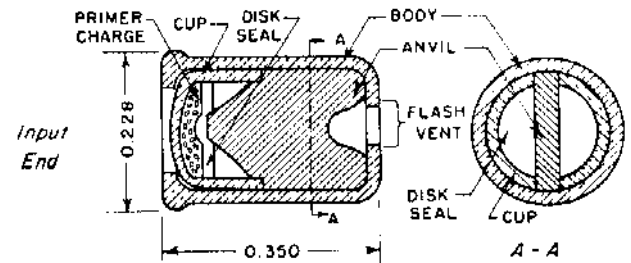

PERCUSSION PRIMER (M39A1)

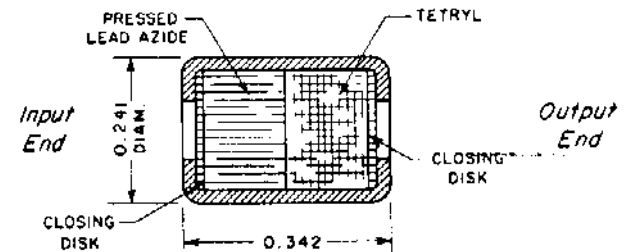

FLASH DETONATOR (M17)

Figure 32. Typical Primers and Detonators (Mechanical)

e. *Squibs.* Metal parts of squibs are identical to those of electric initiators. A typical squib is shown in Figure 34. A low explosive, flash charge is provided to initiate the action of pyrotechnic devices.

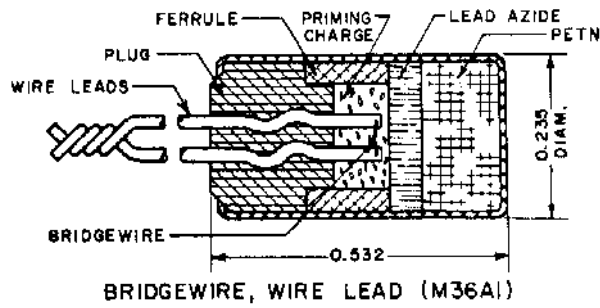

BRIDGEWIRE, WIRE LEAD (M36A1)

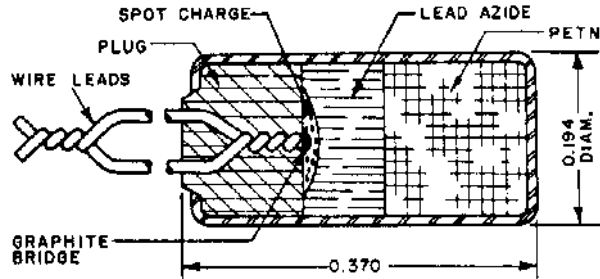

GRAPHITE BRIDGE, WIRE LEAD (M51)

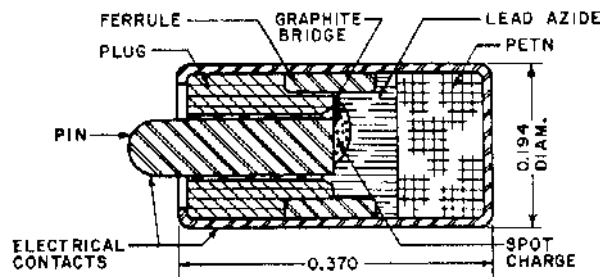

GRAPHITE BRIDGE, BUTTON (T77)

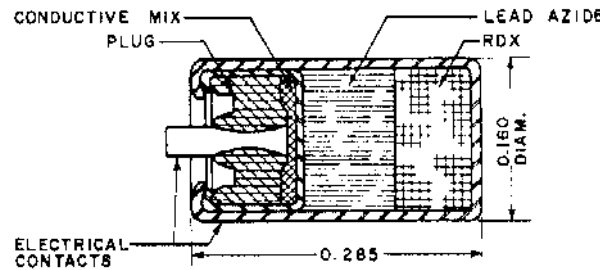

CONDUCTIVE MIX, BUTTON

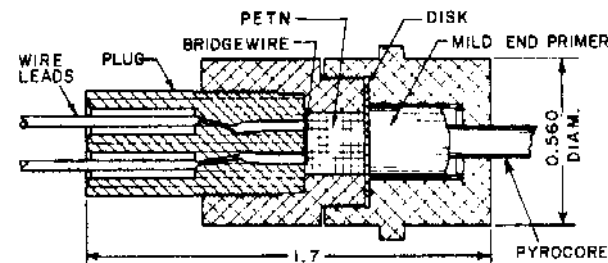

EXPLODING BRIDGEWIRE, WIRE LEAD

Figure 33. Typical Primers and Detonators (Electrical)

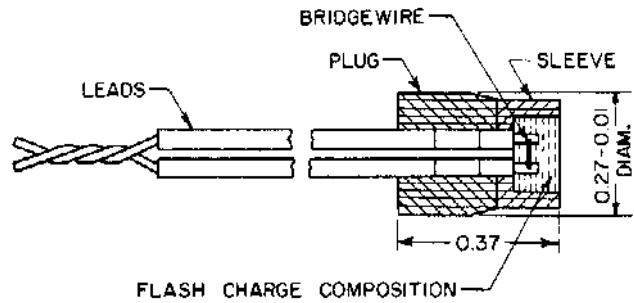

Figure 34. Electric Squib (M2)

f. *Grouping of Initiator Types.* Primers and detonators are commonly placed into two groups, namely mechanical and electrical. Electrical includes those which are initiated by an electric stimulus while all others are mechanical. Therefore, the mechanical group includes not only percussion and stab elements which are initiated by the mechanical motion of a firing pin but also flash detonators which are included because of their similarity in construction and sensitivity. As a group, electric initiators are more sensitive and differ from the mechanical group in that they contain the initiating mechanism, the plug, as an integral part.

One interesting detonator cuts across the two groups, the stab-electric detonator. It is an ingenious adaptation of the button type electric initiator in which the pin is replaced by a small-diameter stab detonator (see Fig. 35). It is intended for use where a detonator is initiated either by means of a stab firing pin (which is centered) or by means of an electric pulse (applied to outside case and stab case as contacts). The two components are designed as conventional separate detonators except that the stab element is small.

Delay detonators are those initiators which contain a delay charge after the priming charge so as to introduce a time delay in the output detonation. These are discussed in Paragraph 57.

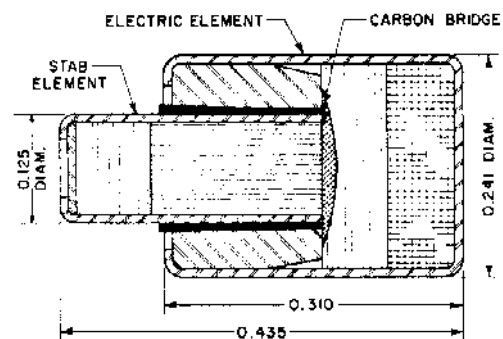

Figure 35. Stab-Electric Detonator (T29)

#### 46. Bases for Selecting an Initiator Type

In selecting an initiator for a specific task, one must consider two main criteria, input and output. For the latter, both type of output and time in which this output is to be delivered are important. In addition to these main criteria, size, weight, cost and reliability should also be considered.

With regard to initiator input conditions, it is probable that the design of the rest of the system has already established whether an electric or mechanical initiator is to be used. If not, the designer is free to choose any system which solves his problem most easily. Mechanical initiators are usually simpler to use than electric ones. If the item is to be completely sealed, a percussion primer is indicated over a stab primer. The need for fast functioning times, less than a few hundred microseconds, or for functioning an initiator which must be remotely located from the source of power can be satisfied most easily by the electric type.

Once having selected the general method of initiation, the next consideration is that of sensitivity. As a general rule, the designer should use the least sensitive item available that meets his other requirements. Stab detonators are more sensitive than percussion detonators. Electric initiators can be made to fall anywhere in a wide range of sensitivities. Initiation by friction or spark cannot be closely controlled so that components initiated in this manner are suitable in only those rare instances where sensitivity is of no concern.

In the case of mechanical initiators, the designer will select the firing pin so that he has complete control of the initiation mechanism. For electric initiators, on the other hand, the power source may be located elsewhere in the system and may have other functions to perform. In such instances, close coordination with the other systems people involved is mandatory so that the initiator will be certain to receive the correct stimulus.

For each initiator, definite firing input conditions are specified. It is wise to hold very closely to these conditions. For example, if the specified input should be designated as 300 volts from a 0.001 microfarad capacitor, then the designer should make certain that intervening circuitry between capacitor and initiator does not reduce the amplitude or modify the wave shape delivered to the initiator. The assumption that a similar amount of energy delivered from a different size capacitor will fire the initiator is risky indeed.

At the same time the designer selects a type of

initiation and an input condition which is compatible with his system, he must consider the type of output desired. As in the case of input, the first choice is relatively simple. The application of the system should indicate whether the output is to be a detonation, a flame or a mechanical function. If, for example, the initiator is to be the first element of an explosive train leading to the detonation of high explosives, then the designer requires a detonation as an output. Unfortunately, available output data are more sketchy than input data so that firm, quantitative choices of output are difficult to make. Adequate testing is usually required.

In addition to the type of output, one is usually concerned with the functioning time of the initiator, which is the interval from delivery of the input to the initiator until the output of the initiator is realized. If very fast initiation is required, an initiator using lead azide as its initial charge will probably be necessary. Somewhat lower acceptable times may permit the use of lead styphnate as the initial charge. Functioning times are usually published as a function of the input stimuli.<sup>1</sup>

In addition to these criteria, one must consider size, weight and cost. The smallest and simplest device is the least expensive, and incidentally the most reliable, but it is limited in versatility, sensitivity and functioning time. Size and weight are always of some importance but are relative. They can become critical in the case of a 20mm fuze while they may be less important in a large missile. In the same manner, the unit cost of an item can be critical if the application calls for millions of devices while it may be of little concern if a relatively few items are to be made. High reliability is expensive but the designer has no choice but to meet this specification when it is required.

Hence, the bases for selecting initiators are not clear cut and require considerable engineering judgement. Two hints may be offered to simplify this task. First, initiators have been developed by the military agencies along certain family lines so that a specific input may be tied to a series of explosive components with different mounting systems, outputs, and functioning times. Conversely, a specific type of output can be traced back to an assortment of initiators requiring differing inputs. These family groups greatly facilitate final selection. Second, many explosive trains of different types exist which have a record of proven performance. Compilations of such past practice make for a good starting place.<sup>2</sup>

## B. INPUT CHARACTERISTICS

### 47. Stab Initiators

*a. Initiation.* The firing pin used for stab initiators, a truncated conical pin, is shown in Figure 9. Firing pin characteristics and the relationship of firing pin velocity to sensitivity are discussed in Paragraph 22.

Table 27<sup>a</sup> lists the compositions of common stab and percussion priming mixtures which are used by the Armed Forces.

*b. Effects of Disk and Cup Thickness.* The energy required to fire stab initiators increases nearly linearly with the thickness of metal which the firing pin penetrates. The zero thickness intercept of the drop height curve may be presumed to be the energy necessary to pierce the metal. Although data are not on hand, it might be expected that use of stainless steel rather than aluminum in this application would result in a less sensitive initiator. There is every reason to expect that this relationship interacts with other variables such as firing-pin dimensions and tolerances and the composition and density of the priming mix.

*c. Effects of Test Apparatus.* Sensitivities of stab initiators are usually specified in terms of weight and height, measured with some standard test apparatus (see Paragraphs 22 and 107). Often the firing pin is not changed in design when the dropped weight is varied. As the weight is reduced to approach that of the firing pin, motion of the pin and energy distribution in the system become quite complex.

The support of the primer is also important. Cushioned support can make an item seem much less sensitive than it is.

Care must also be taken that the movement of the firing pin is not restricted so that its penetra-

tion is less than that which would result from free movement under the action of the drop weight.

### 48. Percussion Primers

*a. Initiation.* Percussion primers are fired with round-nosed firing pins. A typical radius is about 0.050 inch, but variations between 0.023-inch radius and flat had little effect on sensitivity in one investigation.<sup>a</sup> Other firing pin characteristics and the relationship of firing pin velocity to sensitivity are discussed in Paragraph 22. Priming compositions are listed in Table 27.

*b. Sealing Disks and Cups.* The material and thickness of sealing cups affect the sensitivity of percussion primers. As an example, data for the MARK 101 Primer are given in Table 28.<sup>a</sup>

TABLE 28. EFFECTS OF SEALING CUP OR DISK ON SENSITIVITY

<i>Seal</i>	<i>Thickness (inch)</i>	<i>50% Firing Height (inch)</i>	<i>Std. Dev. (inch)</i>
Paper disk	0.003	1.95	0.41
Tin disk	0.005	3.74	0.34
Copper disk	0.005	4.04	0.56
Tin cup	0.005	4.00	0.63
Copper cup	0.002	3.88	0.69
Copper cup	0.003	4.19	0.64
Copper cup	0.004	4.83	0.91
Copper cup	0.005	5.00	0.98

Primer MARK 101, 4-Ounce Ball

In a test of the effects of cup hardness, in which cups ranging from 31.2 to 105.7 Vickers Hardness were used, the trend toward higher drop heights with increasing hardness was apparent but was neither practically nor statistically significant.

*c. Other Variables.* Loading pressure has a negligible effect upon sensitivity of percussion primers in the range from 10,000 to 60,000 psi. Mixtures which do not contain highly soluble components are sometimes loaded wet without significant effect on input properties.

TABLE 27. COMMON PRIMING COMPOSITIONS

<i>Ingredients</i>	<i>Composition (percent by weight)</i>						
	<i>FA70</i>	<i>FA90</i>	<i>PA100</i>	<i>PA101</i>	<i>793</i>	<i>NOL60</i>	<i>NOL130</i>
Lead Styphnate, Basic	—	—	—	53	39	60	40
Lead Styphnate, Normal	—	—	38	—	—	—	—
Barium Nitrate	—	—	39	22	44	25	20
Lead Azide	—	—	—	—	—	—	20
Tetracene	—	—	2	5	2	5	5
Lead Dioxide	—	—	5	—	—	—	—
Calcium Silicide	—	—	11	—	14	—	—
Aluminum Powder	—	—	—	10	—	—	—
Antimony Sulfide	17	12	5	10	—	10	15
Lead Sulphocyanate	25	25	—	—	—	—	—
PETN	—	10	—	—	—	—	—
TNT	5	—	—	—	—	—	—
Potassium Chlorate	52	53	—	—	—	—	—

Although quantitative data are not available, it is clear that firing energy requirements can be expected to increase with thickness and hardness of the primer cup, and with thickness of the layer of primer mix between anvil and cup. Movement of the anvil can drastically reduce the sensitivity to normal firing pin action, while increasing the sensitivity to accidental jars and vibrations. Firm support of the primer is essential.

#### 49. Flash Detonators

*a. Initiation.* The input characteristics of flash initiators are difficult to characterize in terms which are significant indications of performance under usual conditions. Flash initiators are usually initiated by the spit of a primer, the heat from a delay column or other action of previous explosive elements. The exact mechanism of initiation varies with the application. In some cases, the flame may ignite the explosive; in others, either the impact or heat of solid particles or a shock wave may play important roles. No useful, quantitative results have been obtained with gap tests. See Paragraph 21 on adiabatic compression theory.

*b. Effect of Explosive at Input End.* Although U. S. flash detonators have lead azide at the input (also called sensitive) end, lead styphnate has been used in a number of foreign items. Tests indicate that such items should be appreciably more sensitive than lead azide items. Although no data are at hand to support this view, possibly finer particle sizes and lower loading densities should result in more sensitive items. The fact that flash detonators are ignited by rather diffusely distributed heat might encourage the idea that materials like tetryl and PETN, which have rather low ignition temperatures, might be effective at the input end of a flash detonator. However, these materials are much less sensitive to heat pulses of short duration than lead azide or lead styphnate.

*c. Effect of Construction at Input End.* According to a gas blast tester, a flash detonator, in which the sensitive end was the unpierced bottom of an aluminum cup coined to 0.003-inch thickness, required gas pressure about three times as high for initiation as one with a closure consisting of a paper disk 0.0015-inch thick held in place by an aluminum washer crimped into the cup. The sensitivity of flash detonators to initiation by hot gases is determined largely by the heat flow patterns and resulting thermal gradients. A factor which undoubtedly

contributes to the insensitivity of the coined bottom detonator is the continuous metal path from the bottom around to the sides. Although the paper disk, as a better insulator, impedes the flow of heat from the gas to the explosive, it also impedes the transverse flow to the edges which distributes the heat more easily.

#### 50. Electric Initiators

*a. Input Sensitivity.* The input characteristics of electric initiators are subject to precise control over quite remarkable ranges. Items have been designed with threshold firing energies ranging from less than one erg to hundreds of thousands of ergs, with current requirements from hundredths to hundreds of amperes, and resistance from a few hundredths of an ohm to tens of megohms.

Determination of input sensitivity of electro-explosive devices requires sophisticated testing equipment and is considerably more involved than that of stab and percussion detonators. For a discussion of initiation theory, see Paragraph 21 and for details on testing of the item, see Paragraph 108. Input characteristics of specific electro-explosive devices are recorded in the *Electric Initiator Handbook*.<sup>1</sup>

Input sensitivity varies sharply with the type of transducer. Each type, hot bridgewire, exploding bridgewire, film bridge, conductive mix and spark gap, must therefore be considered separately.

*b. Hot Bridgewire Initiators.* Of all initiators, those in which explosives are initiated by electrically heated wires behave most precisely in the manner which can be logically anticipated. For this reason, detonators of this type can be designed quite readily and precisely to any desired input characteristics, within the relatively broad limits imposed by properties of available materials, and the rather simple laws which govern their behavior.

*(1) Flash Charge Explosives.* The explosive in direct contact with the bridgewire is known as the flash charge and sometimes as the spotting charge. Relative sensitivities of a number of explosives are given in Table 7. Normal lead styphnate has the broadest general use at present. For applications where extremely rapid response is needed, lead azide has been used. Lead azide is also finding application in initiators which are required to withstand extremes of temperatures over the extended ranges of modern missile applications (see Paragraphs 36 and 37).

Since the sensitivity of hot bridgewire initiators is determined largely by heat-flow patterns, both particle size and loading density have important effects on sensitivity. Three aspects of heat-flow are involved: transfer between wire and explosive, dissipation through the explosive from the heated surface and longitudinal flow through the wire (end effects). Of these aspects, sensitivity is increased by the first and decreased by the other two. The use of explosives of very fine particle size results in improved contact between explosive and wire and, at the same time, reduces the bulk conductivity of the explosive. Explosives have been ground in ball-mills to take advantage of this tendency. It was found that milling for longer periods resulted in more sensitive initiators.<sup>1</sup> More recently, both lead styphnate and lead azide have been manufactured by processes involving rapid precipitation. The materials so produced are referred to as *colloidal*. Information about these materials is given in specifications MIL-L-17186 for normal lead styphnate and MIL-L-3055A for lead azide. Basic lead styphnate, as procured under specification MIL-L-16355, has particle sizes in the range between 5 and 95 microns, which is highly satisfactory for flash charge use.

Loading density or pressure, as it is increased, may increase sensitivity by improving contact between wire and explosive or decrease it by increasing the rate of dissipation of heat through the explosive. In lead styphnate, loaded at pressures between 1000 and 4000 psi, the latter trend apparently dominates. On the other hand, lead azide loaded at pressures between 3000 and 90,000 psi becomes more sensitive with increasing loading pressure.

(2) *Bridgewire Resistance*. The resistance of a bridgewire is given by

$$R = 0.0005Lr_w/d^2 \quad (28)$$

where the resistance  $R$  is in ohms, the length  $L$  and diameter  $d$  are in mils, and resistivity  $r_w$  is in microhm-centimeters. Resistivities of common bridgewire materials are given in Table 29.<sup>2</sup>

TABLE 29. RESISTIVITIES OF BRIDGEWIRE MATERIALS

Metal	Resistivity (microhm-centimeters)	
	at 20°C	at 500°C
Tungsten	5.5	20
Platinum	10	30
Platinum/Iridium		
90/10	24	39
80/20	31	43
Nichrome*	100	120
Tophet C†	110	132

\* Proprietary alloy of Driver-Harris Co., Newark, N. J.

† Proprietary alloy of Wilbur Driver Co., Newark, N. J.

(3) *Firing Energy and Power*. As pointed out in Paragraph 20, the assumption of a fixed initiation temperature is a valid approximation. In combination with the relatively small variation of volumetric specific heats of solids (illustrated in Fig. 5), this approximation can be extended to the general rule that the firing energy requirement is proportional to the volume of the reaction nucleus, and further, the volume of the reaction nucleus is proportional to that of the bridgewire. Both the variation in critical temperature with size, and the effects of end losses are accounted for in the empirical equation

$$W_t = 25 + 450d^2L \quad (29)$$

where  $W_t$  is the threshold firing energy (50% point) in ergs

$d$  is the diameter of the bridgewire in mils

$L$  is the length of the wire in mils

This equation fits available data within ten percent for lead styphnate loaded either at 3000 to 5000 psi, or "battered" or "spotted."<sup>3</sup>

On the basis of a fixed initiation temperature, the threshold power for initiation should be that required to attain equilibrium with the losses at that temperature. Experimental data indicate that, for short bridgewires where end losses dominate, the firing current requirement of lead styphnate loaded initiators is estimated from the equation<sup>1,2</sup>

$$I_s = 0.4/R_f \text{ (short bridgewire)} \quad (30)$$

where  $I_s$  is the current in amperes required for fifty percent functioning, and  $R_f$  is the resistance of the bridgewire at the firing temperature, which has been assumed to be about 500°C. Note that the current is independent of wire dimensions and material.

For long bridgewires a semi-empirical equation has been derived which relates the current required to overcome the radial losses and which accounts for the tendency for larger wires to initiate "any" given explosive at a lower temperature"

$$I_t = 2.3d/\sqrt{r_w} \text{ (long bridgewire)} \quad (31)$$

where  $I_t$  is the threshold firing current for a lead styphnate loaded initiator with a bridgewire so long that end effects are negligible and  $r_w$  is the resistivity of the bridgewire at the initiation temperature. Assumed values for  $\sqrt{r_w}$  are 4.6 for tungsten and 11.5 for Tophet C.

The total threshold firing current,  $I_t$ , is given by

$$I_t = \sqrt{I_s^2 + I_t^2} \quad (32)$$

However, either  $I_s$  or  $I_f$  is usually so dominant that the other may be neglected. Hence, bridgewires are grouped into short or long class depending on which term dominates in Equation 35.

As pointed out in Paragraph 21, the hyperbolic relationship between power and energy applies quite accurately to wire bridge initiators. Details of the pulse shape are relatively unimportant. The average power, whether in the form of a damped RC discharge or an oscillatory discharge, is the important factor. The response of an initiator to complex sequences of electrical events is predicted by

$$C_p dT/dt + \gamma T = I^2 R \quad (23)$$

The constants for Equation 23 are determined from the limiting threshold energy and current (which can be calculated by means of Equation 32 for  $W_t$  and 35 for  $I_t$ ) using the relations

$$C_p T_t = W_t \quad (33)$$

$$\gamma T_t = I_t^2 R \quad (34)$$

For purposes of prediction of an absolute value of  $T_t$ , the temperature of initiators is not important if  $C_p$  and  $\gamma$  are computed by means of the above relations. The quantity  $T_t$  may be taken as 500°C, which in practice has given reasonably accurate results.

(4) *Response Times.* Condenser discharge firing times vary with flash charge material as well as with bridgewire characteristics and firing conditions. Table 30<sup>4</sup> gives functioning times obtained in one experiment. Figure 36<sup>1</sup> shows functioning times of some typical military items. Azide loaded items, in general, have much shorter functioning times than those loaded with other primary explosives. Since the functioning time of a hotwire initiator is related to the ratio of the firing energy to the threshold firing energy, the variation of individual threshold energies within a lot (as indicated by the standard deviation of the mean) is reflected in functioning times.

In addition, such factors as particle size and porosity, which affect the growth of explosion, are contributing factors in the variability of functioning times. Precise control of these variables and of those which determine threshold firing conditions, can result in highly reproducible functioning times. Careful control in test items has resulted in functioning times equal to calculated detonation transit times within a few hundredths of a microsecond (for firing conditions of 600 volts discharged from a 0.01 microfarad condenser—18,000 ergs compared with a threshold of about 1300 ergs).

Functioning times at relatively low steady currents approach those predicted by Equation 35 which is a solution of Equation 23<sup>5</sup>

$$t = \frac{C_p}{\gamma} \ln \frac{I^2 R_f}{I^2 R - \gamma T_t} \quad (35)$$

(5) *Typical Design Problem.* Design a hot wire initiator with a resistance of two ohms, an all-fire energy of 42,000 ergs, and a no-fire energy of 15,000 ergs.

Solution: Since firing probabilities tend to be normally distributed, with respect to the logarithm of input energy, the fifty percent point should be at the logarithmic mean of the all-fire and no-fire points

$$W_t^2 = 15,000 \times 42,000$$

$$W_t = 25,000$$

From Equation 29

$$W_t = 25 + 450 d^2 L = 25,000$$

$$d^2 L = 55$$

Assuming a Tophet C bridgewire and using Equation 28

$$R = 0.0005 r_w L/d^2 = 2 = 0.0005 \times 110 \times L/d^2$$

$$L/d^2 = 36$$

Solving for  $L$  and  $d$ , we get

$$(L/d^2)(d^2 L) = L^2 = 55 \times 36$$

$$L = 45 \text{ mils}$$

and

$$d^2 = 55/45 = 1.22$$

$$d = 1.1 \text{ mils}$$

Thus, the requirements are met by an initiator with a lead styphnate flash charge and a Tophet C bridgewire 1.1 mil in diameter and 45 mils long. If the mechanical design of the item makes a longer bridgewire desirable, the requirements can be met with wires of lower resistivity. Where the length is fixed by other considerations, Equation 29 may be solved for the diameter corresponding with the given length. The bridgewire dimensions so obtained may then be substituted in Equation 23 to determine the resistivity corresponding with the desired resistance. A suitable material may then be selected from Table 30. Should the value of resistivity be below that of available materials, "heat sinks" can be used which are essentially blind terminals to which the wire is soldered at one or more points along its length. The equations are applied to the design of such a system by considering each segment separately as a series element.



TABLE 30. FIRING TIMES OF HOT BRIDGEWIRE INITIATORS

Explosive	Milling Time (hr)	Capacitance (microfarad)		
		0.5	0.05	0.0047
Polyvinyl Alcohol Lead Azide	24	1.12- 1.26	1.09- 1.38	1.41- 5.00
Dextrinated Lead Azide	64	1.08- 2.43	1.12- 2.43	3.46- 4.95
Silver Azide	24	1.13- 1.47	1.17- 1.56	1.9 - 13.1
Silver Azide	64	1.23- 1.89	1.23- 2.36	1.3 - 43.1
Normal Lead Styphnate	24	11.8 -12.5	10.0 -20.6	13.1 -374.4
Normal Lead Styphnate	64	10.0 -13.7	10.6 -13.1	10.0 -381.2
Basic Lead Styphnate	24	10.6 -13.1	11.2 -23.1	20.0 -430.0
Basic Lead Styphnate	64	4.4 -13.0	12.5 -14.4	10.6 - 60.6
Diazodinitrophenol	24	8.33- 9.00	10.0 -13.8	91.2 -362.5

50 mg loads of explosives, voltage of 450 volts. Times are in microseconds.

Note that while hot bridgewire initiators are more readily designed by calculation than most initiators, their exact input characteristics are affected by a wide variety of variables which are discussed above as well as in Paragraph 21. The formulas are empirical and in reasonable agreement with performance data of military fuze items loaded with colloidal or milled lead azide or lead styphnate. Since it is impractical to specify in complete detail some variables (such as particle shape, particle size distribution and the degree of contact between explosive and bridgewire) which have been found to affect input characteristics, experimental verification of these characteristics is always necessary. If desired characteristics have been

specified within close limits, it is well to be prepared to adjust one or another of the variables involved after tests of a preliminary sample.

c. *Exploding Bridgewire Initiators.* As pointed out in Paragraph 23, exploding bridgewire (EBW) initiators are defined as those which fire only when subjected to electrical conditions conducive to explosion of their bridgewires. The initial charges of EBW initiators are secondary explosives such as PETN or RDX. Hence, they are relatively safe from initiation by direct application of heat and external mechanical influences (impact or vibration) or from electrical input of most any kind except the highly specialized pulses for which they are designed.

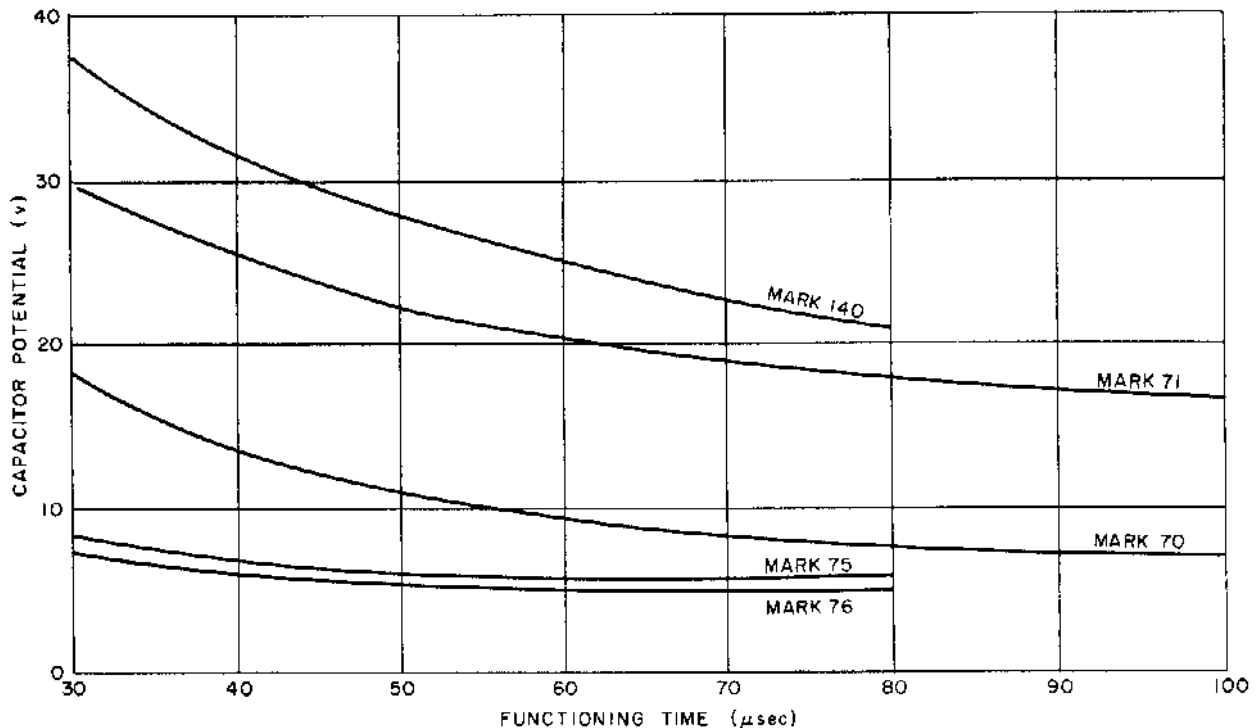

Figure 36. Functioning Times of Hot Wire Bridge Initiators

If an EBW initiator is subjected to a gradually increasing current, the bridgewire can burn out at some point without exploding and initiating the explosive. The rate at which the current must rise ( $di/dt$ ) to result in firing is an important characteristic of an EBW device. For typical EBW initiators, this rate must equal or exceed  $10^9$  amperes per second. Remembering that this rate is equal to the quotient of voltage by inductance and that typical firing circuits have output voltages in the range of a few thousand volts, the maximum permissible inductance is of the order of a few microhenries, which is close to the minimum practical value for circuits usable in ordnance. The high rate of rise results in concentration in the outer layers of the bridgewire, and an increase in the effective resistance from the static value of a few hundredths of an ohm to a dynamic value of a few ohms. In addition to these electrical phenomena, the initiation of explosives by exploding bridgewires involves interactions of firing voltage and capacitance, bridgewire dimensions, melting point, boiling point, heats of fusion and evaporation, resistivity, coefficient of resistivity, heat capacity, surface tension in the liquid state, explosive composition, particle size and shape and the distributions thereof, charge dimensions and confinement and some other factors. Hence, EBW initiators do not lend themselves to precise calculation.

(1) *Bridgewire Dimensions and Materials.* Clearly, the smaller the volume of a bridgewire, the less energy is required to cause it to explode. However, a given amount of energy in a given circuit will not necessarily result in increasingly vigorous explosions as the size of the wire is reduced. A smaller wire, for example, will generally vaporize sooner. If this occurs before the current approaches the maximum value, as determined by the circuit, most of the energy will be dissipated in an arc discharge, generally diffused in a volume much larger than that of the original wire. The resulting explosion may thus be less intense than that from a larger wire. This effect, combined with the characteristics of practical firing circuits and the properties of explosives used, will cause the threshold firing energy or voltage of an EBW device to reach minima at optimum values of bridgewire diameter and length which have, unfortunately, not yet been defined.

Of the materials tested, platinum, gold and copper have given the best results.<sup>6</sup> Nichrome, tungsten and silver, under circumstances for which data are available, require more energy than the

first named materials. Gold and platinum have been preferred because of their corrosion resistance.

(2) *Explosive Materials.* PETN is, for the present, the most widely used initial charge material for EBW detonators. RDX and HMX, which are desirable because of their better thermal stability, are somewhat harder to initiate.

EBW devices are most sensitive when loaded with explosives of very fine particle size at densities close to their bulk densities. The energy and voltage requirements rise sharply with increasing loading density.

d. *Film Bridge Initiators.* Conductive films may be applied to the surfaces of insulators by a variety of techniques, including chemical precipitation; painting; drying of suspensions and solutions; writing, as with a pencil, crayon, or pen; plating; vacuum evaporation; sputtering and spraying. Most of these techniques have been used at one time or other to produce bridges which can be heated or exploded to initiate explosive reactions.

(1) *Initiation Mechanism.* The initiation mechanism of film bridge initiators is complex (see Paragraph 21). Hence film bridges cannot be designed by computation as can hot wire bridge initiators. Typical complications result from the fact that film thickness is much less uniform than is the diameter of a drawn wire and that various paths exist between the electrodes. Where the film is a semiconductor with a negative resistance coefficient, like carbon, variations in film thickness and path length combine with the negative resistance coefficient to channel most of the current into one or a few preferred paths. Since the volume of material through which most of the current flows is only a small fraction of the film, initiators with carbon film bridges are among the most sensitive in use.

Although some experimental results have been obtained with a variety of experimental film bridge initiators,<sup>7</sup> the only type applied in standard fuzes has been the low-energy graphite bridge type.

(2) *Graphite Bridge Films.* Bridges of graphite bridge initiators are all made by essentially the same process. A droplet of a colloidal suspension of graphite in water is deposited on a surface which consists of two or more metal electrodes separated by, and often imbedded in, an insulator. The electrical and electrothermal characteristics of a bridge made in this manner are determined not only by such aspects of the design as spacing and configuration of the electrodes and specified dilution

of the droplet but also by the manner of droplet application.

The input characteristics of graphite bridge initiators (both resistance and sensitivity) are determined, at least in part, by the chance distribution of the particles of graphite as they are deposited. Consequently, the item to item variation is quite large. The acceptable resistance range for Army items is 1000 to 10,000 ohms, while that for Navy items is 700 to 14,000 ohms. Generally, several hundred ergs of input energy are required for reliable initiation.

*e. Conductive Mix Initiators.* By mixing explosives with metals or other conductive materials, mixtures can be prepared which are electrically conductive, and in which sufficient current density results in initiation of a self-propagating reaction of the explosive. The input characteristics are functions of electrode dimensions, spacing, configuration, particle size shape and distribution of each component of the mixture and intimacy of the mixture, as well as its composition. Flaked or powdered metals as well as graphite and acetylene black have been used for the conductive component of the mixtures while both common primary and secondary explosives serve as the explosive component.

Conductive mix initiators are rarely used. The permutations of the variables are so numerous that a systematic study of their results has not been completed. A number of these results are discussed in Paragraph 21. In some cases, rather ritualized schedules of grinding, mixing and loading are necessary to attain the desired characteristics.

*f. Spark Gap Initiators.* Electric sparks of rather low energy content will initiate some explosives (see Paragraph 23). The earliest electric blasting caps were spark gap or "high tension" caps. The high voltage necessary to fire spark gap initiators is still a limitation to their usefulness. As the gaps are reduced to lower the threshold firing voltage, the critical voltage varies so sharply with both gap length and electrode configuration that normal manufacturing variation makes input characteristics difficult to predict. This situation is not improved by the presence of a powdered explosive between the electrodes. For voltages above a few thousand volts, spark gap initiators can be made with more reproducible characteristics. Spark gap initiators are even more rare than conductive mix detonators.

*g. Squibs.* From the standpoint of input, squibs are identical to other electric initiators. Since most

squibs are wirebridge devices, they are designed like hot wirebridge initiators described in the foregoing. The explosive is one of the flash charges listed in Table 29. Some squibs have a second charge of black powder or similar material to initiate materials which are more difficult to ignite.

Squibs are used in pyrotechnic trains.<sup>8</sup> Initiators for propellants are also called squibs at times. However, these are larger components and should be called ignitors.

## C. OUTPUT CHARACTERISTICS

### 51. Output of Primers

The output of a primer includes hot gases, hot particles, a pressure pulse which, in some cases, may be a strong shock and thermal radiation. Measurable quantities which have been used to characterize primer output include: the volume of the gas emitted, the impulse imparted to a column of mercury by the pressure pulse, the light output as measured by a photocell, the temperature rise of a thermocouple exposed to the output gases and particles, the ionic conduction between a pair of probes exposed to the output, the pressure rise in a chamber in which the output is confined, the propagation velocity of the air shock, the hangfire, namely the time lapse between supply of mechanical energy to the primer and initial primer output, and flame duration. Some of the more brisant primers emit pressure pulses of sufficient magnitude to give measurable results in the sand test and lead disk test (see Paragraph 109). Each of these measurable quantities has been related to effectiveness in one or another application by experiment, theory or intuition. However, no general quantitative relationship of value to a designer has been developed. The design of a primer for appropriate output must be based on precedent and the following generalities

(a) Both gaseous products and hot particles emitted by primers play important roles in ignition.

(b) The effectiveness of the gaseous products in ignition increases directly with temperature and pressure. Since the pressure is related inversely to the enclosed volume, an increase in this volume or a venting of the system may call for primers of greater output.

(c) It has been shown experimentally that the heat of an enclosed body of gas is distributed quite uniformly over the surface to which it is exposed.<sup>9</sup> Thus, the insertion of baffles or the introduction of irregularities which increase the total surface, both

inert and reactive, exposed to the primer gases may necessitate the use of a primer with more output energy.

(d) Hot particles of solids or globules of liquids are particularly effective in the ignition of materials with high thermal diffusivities (such as those containing appreciable proportions of metal) or of those whose melting points are well below their ignition temperatures.

(e) Hot particles and globules establish a number of reaction nuclei, rather than burning along a uniform surface. This action may be undesirable in short delay columns, or in propellant grains designed for programmed combustion. Where the particles or globules are large, or have high enough velocities to penetrate beneath the surface, serious problems may result.

(f) The blast effects of pressure pulse and accompanying gas movement are both favorable and adverse in igniting by means of a primer. Although they result in more rapid heat transfer between gases and solid materials which are to be ignited, they may also "blow out the flame" by moving the hot gaseous products from contact with the combustible material.

(g) In some applications, shock waves which are too strong may damage the structure of either reactive or inert material in such a manner that control of system behavior is lost.

(h) The reproducibility of the time of a delay element is related to the reproducibility of the output of the primer which initiates it. The times of short obturated delay elements are particularly sensitive to variations in primer output.

(i) When a primer is used to drive a firing pin (this combination is used where the sensitivity of a stab primer is needed in combination with a delay of the obturated type, which requires a percussion primer), the important aspect of primer output is the momentum it is capable of imparting to the firing pin. Where the output gases are reasonably well contained, the impulse as measured in the gas volume and impulse machine is a reasonable gage of output. Where the system is essentially vented, blast type phenomena, perhaps as indicated in air shock velocity or the lead disk test, are more significant.

## 52. Output of Detonators

*a. Parameters of Detonator Output.* As its name implies, a detonator is intended to induce detonation in a subsequent charge. The two features of its

output which are useful for this purpose are the shock wave it emits and the high velocity of the fragments of its case.

Although it is possible to envision detonator designs which are effective in inducing detonation without detonating themselves, the output effectiveness of detonators of current designs is directly related to the quantity of the explosive which detonates, and to the vigor of this detonation. These quantities are somewhat less predictable than in most other components because the transitions from burning to detonation and from low order to high order detonation take place in the detonator.

These transitions, as pointed out in Paragraph 19, can require anything from a hundredth of an inch to the whole length of a detonator, depending upon such factors as loading density, composition, particle size, confinement and column diameter. However, recent developments in lead azide production have resulted in materials in which these transitions require so little explosive that the output of a detonator can be predicted with a fair degree of confidence.

The effective output of a detonator includes factors of pressure, duration and area over which the pressure acts. Clearly a simple product of these quantities is inadequate as a characterization because a low pressure of either long duration or large extent would obviously be ineffective.

*b. Measurement of Detonator Output.* Detonator output is difficult to characterize except in terms of the characteristics of a subsequent charge. This is to be expected because the transmission of detonation involves the interaction of quantities associated with the acceptor as well as with the donor.

Detonator output is measured by means of gap or barrier tests, sand test, copper block test, lead disk test, steel plate dent test, Hopkinson bar test and in terms of the velocity of the air shock produced. These tests are described in Paragraph 109.

No known measurement technique yields a quantitative measure of the output of an individual detonator which is usable, without reservation, as a criterion of the effectiveness of the detonator.

*c. Explosives Used in Detonators.* In the past, a detonator was considered to be incomplete unless it contained three charges of different explosives: a priming or flash charge for initiation, an intermediate charge in which the transition from burning to detonation takes place and a base charge to maximize output. Recent trends have been toward the combination of these functions, but separate dis-

cussion is still appropriate. Priming and flash charges are discussed in Paragraphs 47-50 under input.

(1) *Intermediate Charges.* The properties of a primary explosive which promote the growth of detonation have not been quantitatively defined. From a practical point of view, the superiority of lead azide over other available explosives in this respect is such that no other explosive is used in a current detonator for fuze use (except in exploding bridgewire applications).

Most detonators in current production have intermediate charges of dextrinated lead azide. However, the lot-to-lot variation in the growth of detonation in dextrinated lead azide, particularly at loading densities necessary for the output potentialities of this compound, has been a factor in the trend toward the use of such other forms as RD1333. Although silver azide appears to be superior to the best lead azide in this respect, it may never be available in sufficient quantities to be considered for production. In exploding bridgewire detonators, the function of the intermediate charge (as well as initial charge) is served by an exploding wire.

(2) *Base Charges.* It has been the practice to include base charges of booster type explosives at the output ends of detonators. The base charges of most electric detonators in current production are PETN. Those of flash and stab detonators of early designs are tetryl and of more recent designs, RDX. The difference between electric and non-electric items is that the former evolved from commercial electric blasting caps, in which PETN is widely used, while the latter have a much longer history of development within military agencies. A number of experimental electric detonators have been made with RDX and HMX base charges to obtain better stability at high temperatures. However, the improvement in this respect was not as great as anticipated.<sup>10</sup> Meanwhile, the superiority of lead azide to any of these materials in thermal stability has combined with the considerations discussed below to cause a trend toward the elimination of explosive base charges.

The limitation of the size of a base charge is generally that of the volume available. Thus, one criterion of the relative effectiveness of a base charge explosive is its volumetric heat of detonation. Another criterion is the detonation pressure. (Detonation velocity has often been used as a criterion but is probably involved mainly as a factor in the detonation pressure.) In Table 31,<sup>9</sup> volu-

metric heats of explosion and detonation pressures of lead azide and various base charge explosives are given.

TABLE 31. HEATS OF EXPLOSION AND DETONATION PRESSURES

Explosive	Volumetric Heat of Explosion		Detonation Pressure	
	Voidless (cal/cc)	Pressed at 10,000 psi (cal/cc)	Voidless (k bar)	Pressed at 10,000 psi (k bar)
Lead Azide (dext.)	1450	970	317	158
Lead Azide (pure)	1760	1100	394	161
Tetryl	1900	1720	276	221
PETN	2440	2260	327	264
RDX	2330	2050	354	257
HMX	2580	2070	414	261

In general, the comparisons made for the various explosives pressed at 10,000 psi are of more practical significance than those made for voidless materials. Most detonators are loaded at pressures in this range which is a good compromise value for several practical reasons. The newer forms of lead azide, in contrast, are apparently immune to dead pressing (see Paragraph 17) except at pressures near or above 100,000 psi, so that realizable output approaches that for voidless lead azide, which is comparable to that of a base charge explosive. Colloidal, PVA, or RD1333 lead azide, loaded in place of a base charge at pressures of the order of 50,000 psi, may be expected to result in detonators similar enough in output to detonators of similar design with base charges of booster explosives to be indistinguishable from them. Some investigators report that RD1333 lead azide and PETN base charges, loaded in the same volumes, have equal output. Others show an increase in output as a PETN base charge displaced lead azide.<sup>11</sup> The lot-to-lot variations in loading characteristics of both PETN and lead azide probably account for part of this disagreement. Variations between test procedures and output criteria used by various investigators might also affect relative as well as absolute output of variously loaded detonators.

In substitution of base charge explosives, bear in mind that RDX and HMX are less sensitive than PETN. An intermediate charge which is adequate for reliable high order initiation of PETN may not be sufficient for maximum or reproducible results with these materials. Experimental investigations of such substitutions should be made in full cognizance of the effects of confinement on the growth and transfer of detonation, as outlined in Paragraphs 20 and 25. Tests which are carried on with better confinement and consolidating pressures than occur in service may be misleading.

*d. Explosive Quantities and Dimensions.* The total energy released by a detonator is the sum of the products of the heats of detonation and the quantities of the various explosives used. Of this energy, only that from the explosive which detonates high order is effective output. In general, this includes the base charge and part of the intermediate charge. Where the intermediate charge is dextrinated lead azide, the fraction which detonates may vary appreciably with loading density, confinement, and lot-to-lot variations in the lead azide. The azide which actually detonates must be sufficient to initiate the base charge. In current detonator designs, this is assured by the use of at least 100 milligrams of lead azide. A rule of thumb calls for a 0.10 inch minimum column height. The necessary quantities of such materials as PVA, colloidal, and RD1333 are considerably smaller than this. At this time, design practices have not developed to a point where a conservatively reliable minimum quantity of such materials can be specified.

Most detonators are considerably longer than their diameters. This configuration is dictated by both fuze and detonator design considerations.

*e. Loading Density of Explosives.* The growth of detonation is most rapid in explosives loaded at densities well below those usually used in military items. On the other hand, the effective output of stable detonating explosives increases sharply with density. Thus, a given quantity of intermediate or base charge explosive has a maximum effective output at some optimum density. The value of this optimum is affected by the composition and particle size of the explosive, the vigor with which it is initiated, the dimensions of the charge and the confinement afforded by surroundings. For the conditions in the usual fuze application, the optimum density for dextrinated lead azide and normally used base charge materials is obtained by loading at between 10,000 and 20,000 psi. As indicated in the foregoing, the optima for PVA, colloidal and RD1333 lead azide are much higher. For most lots of these materials, in fact, the optimum loading pressure is beyond practical limits of production tools.

The optimum density for the initial charge of an exploding bridgewire detonator is less than one gm/cc. For some such devices, it has been found advantageous to load by increments at varying densities, increasing in stages, as for example, 1.0, 1.2, 1.4 and 1.6 gm/cc. Such gradual increases are less necessary in PETN than in RDX and other less sensitive explosives.

*f. Confinement of Explosives.* Confinement is an important factor in both the growth of detonation (see Paragraph 20) and the effective output of stable detonation (see Paragraph 25). The confinement of a detonator is somewhat difficult to describe in quantitative terms, because different properties of the confining structure are involved in the promotion of detonation growth and in augmentation of the output of stable detonation, and because of the relative complexity of the structure and configuration of detonators. The confinement afforded by surrounding fuze structures as well as that of the detonator itself can contribute significantly to the effective output of a detonator.

In the early stages of the growth of detonation, the detonator case, closure, and the surrounding structure should be considered as a container of high pressure gases. At the earliest stages, *tightness* (the absence of leaks) is the most important factor. As the growth progresses, the strength of the container becomes more important, while the importance of leaks diminishes.

As the detonation approaches its stable rate, the pressure exceeds the bursting strength of any feasible container and confinement is mainly a matter of inertia. In relatively thin-walled containers, the confinement afforded by the inertia of the case is related to the weight ratio of case to charge. For heavy walls (where the thickness equals or exceeds the charge radius), the shock impedance of the surrounding material (Table 11) is the best criterion of its effectiveness in confinement.

The confinement afforded by any component is related to its proximity to the explosives. For example, a heavy steel case surrounding a thick plastic charge holder contributes little to the confinement of the explosive inside the charge holder.

The rearward confinement afforded by the plug of an electric detonator can contribute significantly to its output. Some of the smaller electric detonators have appreciably greater output than have stab or flash detonators of nearly identical loading.

## D. CONSTRUCTION AND FABRICATION

### 53. Initiator Cups

Initiators usually consist of simple cylindrical metal cups into which explosives are pressed and various inert parts inserted. MIL-STD-320 describes design practices and specifies the standard dimensions, tolerances, finishes and materials for

initiator cups. In general, all initiator designs should conform to this standard. However, it is not the intent of the standard to inhibit the development of new concepts so that an occasional departure from the standard may be necessary for special circumstances.

An example of a deviation from standard design is a coined bottom cup. For flash and stab initiators, it is desirable for both ends to be thinner than the walls. Cups with standard holes are used in which the holes are covered from the inside with thin metal disks. However, this construction results in a sealing problem at both ends. An alternative method, which has been used extensively in recent years, is use of a cup in which the central portion of the bottom is coined to an appropriate thickness (see Figure 37).

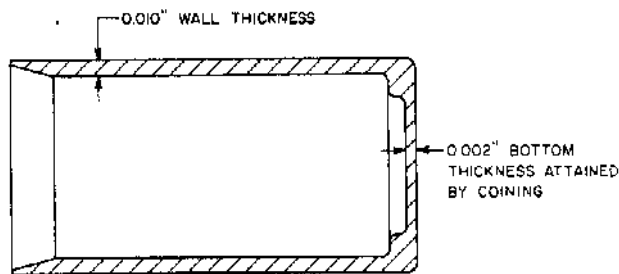

Figure 37. Coined Bottom Cup

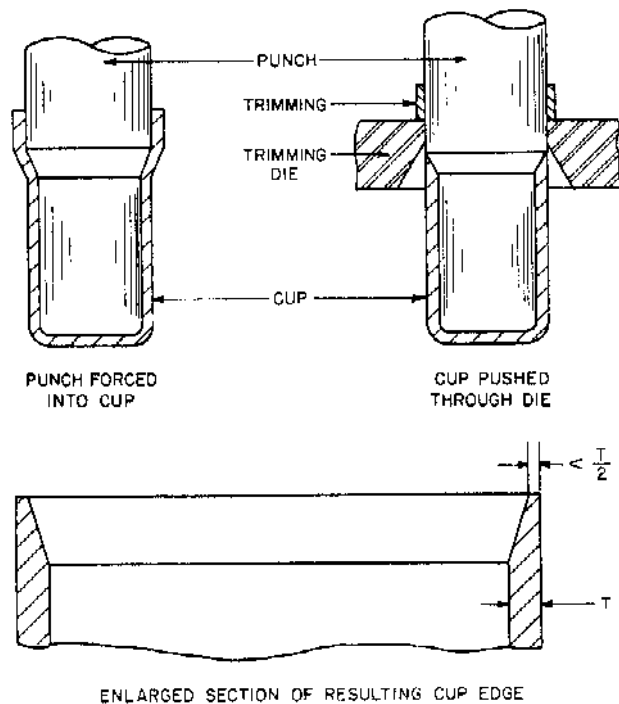

Figure 38. Punch Trimming of Initiator Cups

After drawing, cups are punch trimmed. In this process, the cup is expanded by means of a punch, the diameter of which is slightly larger than the outside of the cup, to the point at which it is to be trimmed. The cup is then forced through a die which fits the punch, trimming off the expanded part (Fig. 38).

Initiators are usually closed by crimping with a succession of conical crimping tools (Fig. 39). Cups for flat ended cylindrical items should be made 0.030 inch longer than the finished length to allow for crimping.

In selecting one of the standard cup materials from MIL-STD-320, it is important to consider compatibility of metals with one another and with the explosives used (see Paragraph 39).

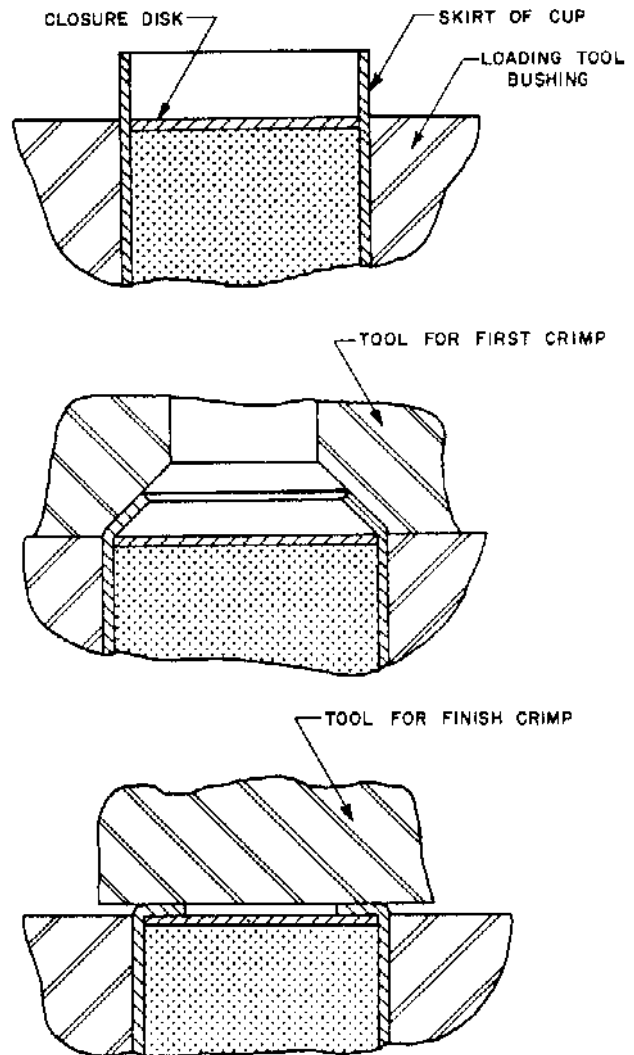

Figure 39. Initiator Cup Crimping

#### 54. Explosive Loading

Initiators are loaded by pressing powdered explosives into the cup. For details of loading procedures and considerations, see Paragraph 95. For flash and spotting charges of electric initiators, see Paragraph 56.

Most fuze initiators are loaded at between 10,000 and 20,000 psi. Exceptions include percussion and stab priming mixtures which may be loaded at 30,000 to 80,000 psi and the flash charges of electric initiators which are loaded at 3000 to 5000 psi, or sometimes are "battered" into a cavity in the form of a paste, including solvent and binder.

As suggested in Paragraph 52, experimental evidence indicates performance advantages may result from the use of loading pressures between 40,000 and 80,000 psi with PVA, colloidal, and RD1333 lead azide. However, the practicality of using such pressures in production has not, at this time, been demonstrated.

Where a charge of one explosive is longer than its diameter, the usual practice is to load it in increments not over one diameter long. Shorter increments are sometimes used for a precise control of density.

The base charge of electric detonators is loaded first, the initiator plug forming the closure. The usual practice for stab and flash detonators is to load the sensitive end first. Some reasons for this practice are

(a) "Press blows" are most probable when pressing the priming mix. Both hazards and resulting damage are minimized if this is the only material present.

(b) The greatest sensitivity of stab mixtures is obtained when they are loaded at pressures higher than those usually used for intermediate and base charges. By loading this material first, the charge may be loaded at any appropriate pressure without overpressing the other charges.

(c) The priming mix, which is most vulnerable to moisture and other atmospheric gases, is farthest from the crimped end (in a coined bottom cup).

(d) The base and intermediate charges have their density gradients in the most advantageous direction. The reaction propagates from the low density end, which is most sensitive to flame or detonation initiation, to the high density end, which has the most effective output.

#### 55. Mechanical Initiators

*a. Stab and Flash Initiators.* Stab and flash initiators are the simplest explosive devices, consisting

of a cup filled with the explosive charges. Where a pierced cup is used the opening is covered with a disk. From the standpoint of compatibility, the best disk material is the same as that of the cup. However, thickness and material of the disk may be dictated by sensitivity requirements. Paper disks, usually supported by metal washers, have been used for the bottom closure of flash detonators where there is no sealing requirement because most of the sensitivity gained by the use of paper is lost if the paper is coated with sealant. The loading tool base has a protrusion to fit the pierced hole so as to form, with the remaining edge of the bottom, a flat surface for the support of the disk. Disks for the closure of the output end are, in general, somewhat heavier to make crimping more satisfactory. A commonly used thickness is 0.005 inch.

It is the usual practice to paint the ends of stab and flash initiators with a lacquer type sealant. Although waterproof seals have been shown to be effective in most instances, moisture proofing according to the Temperature and Humidity Cycling Test (see Paragraph 110) is seldom achieved.

*b. Percussion Primers.* A percussion primer consists of a cup, a small charge of priming mix and an anvil. Sealing disks or cups are sometimes used. Some anvils are held in place only by a force fit and protrude beyond the edges of the cups. The final seating of the anvils takes place as they are crimped in place. Adequate square shoulders should be provided for the anvil support.

The relatively thin layer of priming mix used in percussion primers makes it possible to load these items wet with the expectation that they can be dried in a reasonable amount of time. Many of the primers used for small arms are loaded wet.

#### 56. Electric Initiators

*a. Initiator Plugs.* Electric initiators differ in construction from mechanical initiators mainly in that they include plug assemblies, which are essentially means of supporting and insulating a pair of electrodes. The electric firing stimulus is carried through these electrodes to bridges or other means of converting electric energy into a form to which the explosive will respond.

Most plugs are molded of phenolic material. Powdered iron plugs are now being evaluated. They are designed to attenuate radio-frequency or other spurious electrical signals.<sup>12</sup> The plug may have a front region of reduced diameter onto which a ferrule or charge holder is forced to serve as a



receptacle into which the flash charge is pressed or "battered" (see Figure 33). For wire lead assemblies, two wires are imbedded in a phenolic plug with the plug acting as the insulator. The button type assembly consists of two concentric stainless steel components, pin, and ring shaped plug, cemented together and insulated from one another by a thin layer of synthetic resin adhesive. In addition to their ruggedness and adaptability to certain fuze designs, the plugs provide rearward confinement which significantly augments the output of the initiators. Glass-kovar plug assemblies and other metal ceramic seals provide a basis for the development of hermetically sealed units. Such assemblies have found widespread application in explosive actuated devices, discussed in Paragraphs 84 and 85.

*b. Bridging Techniques.* Most electric initiators are wire bridge items and most of the remainder are film bridge initiators. Several techniques have been developed to apply wires to the electrodes of the wire bridge type.

(1) *Soldered Bridges on Raised Terminals.* Soldering a bridgewire to a raised terminal is, of course, the obvious way to connect one wire to another. (See M36A1 detonator, Figure 33.) For quantity production, a large number of plugs are lined up in a fixture and a length of the bridging wire is stretched so as to bisect the tips of the terminals. The group is bridged by touching each tip with a properly tinned soldering iron. Subsequent operations include removal of all flux, trimming the ends of each bridge at the outside edges of the terminals, and pinching the terminals together to put a little slack in the wire. Although a hand process, it is reasonably fast. One of the principal disadvantages of this technique is that the suspended wire is easily broken by press loading of the explosive.

(2) *Flush Soldered Bridges.* This fastening technique is similar to that with raised terminals, except that the lead wires are ground flush with the face of the plug. Explosives may be pressed against such a bridge. However, battered or spotted charges may not contact a flush bridge over as large a fraction of its surface as they would cover a bridge on raised terminals.

(3) *Welded Bridges.* Where soldering is impractical, bridgewires may be resistance welded. In addition to eliminating the soldering flux, this technique reduces the number of metals involved to a minimum. The welding of bridgewires, in its ultimate development, is ideal for high rate automatic pro-

duction. However, in its present state, it is somewhat slower than soldering. Button type plugs when used with wire bridges are usually bridged by welding.

(4) *Graphite Film Bridges.* Plugs for graphite bridge initiators are made by molding the plastic about a twisted pair of enameled wires, and then grinding the surface flush. This leaves a plastic surface with two metal islands separated by twice the thickness of the enamel. A droplet of a diluted colloidal suspension of graphite in water is applied over the point of closest approach of these islands and allowed to dry. While hand daubing of graphite film remains something of an art, a recently developed automatic bridging machine has permitted the application of fairly uniform films.<sup>13</sup>

*c. Bridgewire Materials.* Bridgewire is selected first for its resistivity. Next its adaptability to the bridging process and its compatibility with the explosive to be used must be considered. The very small size of the usual bridgewire results in a situation where an amount of corrosion, which might be negligible elsewhere, is sufficient to part the wire. These considerations limit the choice to relatively few materials (see Table 30).

Gold, platinum and platinum-iridium are nearly impervious to chemical attack, and are relatively easy to solder. However, the low tensile strengths of these materials makes them difficult to handle without breakage in sizes much under a thousandth of an inch. They are extensively used in EBW devices. Nichrome and Tophet C are similar to stainless steel in their corrosion resistance and compatibility characteristics. Although somewhat more difficult to solder, their higher strength, combined with favorable electrical properties, has resulted in their use in most heated wire initiators, in diameters down to about 0.4 mils. Its extremely high tensile strength makes tungsten the preferred material for extremely small bridgewires. It is available in sizes down to 0.1 mil and is not too difficult to work with in these sizes.

*d. Spark Gap Plugs.* A plug for a spark gap initiator is like a plug used for graphite film devices without the graphite film. The gap between the terminals is about 0.001 inch or less.

*e. Flash and Spotting Charges.* The explosive in intimate contact with the electric bridge is called a spotting charge. Only a small quantity (on the order of 5 mg) is used. A ferrule or charge holder may serve as a receptacle into which the flash charge is

"battered" or pressed. Milled lead styphnate mixed with nitrocellulose lacquer is the currently used spotting charge. For flush bridging, dry pressed flash charges have been used in a number of initiators. The pure explosive and uniform density of pressed flash charges makes them more reproducible, particularly in functioning time.

The resistance of graphite film bridges is

stabilized to some extent by covering them with a relatively thin layer of a lead styphnate-lacquer mixture which is applied as a meniscus to the plug surface. Such a charge, known as a spotting charge, is used on some wire bridges as well as on most graphite film bridges. It has been found that faster functioning can be obtained by the use of lead azide, either milled or colloidal.

## REFERENCES

### CHAPTER 5

*a-i Lettered references are listed in Paragraph 12 (end of Chapter 1).*

1. R. H. Stresau, L. D. Hampton and J. Kabik, *Firing Characteristics of Electric Initiators Made by the Spray Metal Process*, Naval Ordnance Laboratory (White Oak), Memorandum 10771, 30 March 1950.
2. *Handbook of Chemistry and Physics*, The Chemical Rubber Publishing Company, Cleveland, 43rd Edition, 1961-1962.
3. G. W. Peet and L. F. Gowen, *Evaluation Test Results on Service and Experimental Squibs*, Naval Ordnance Laboratory (White Oak), NAVORD Report 6061, 4 March 1958.
4. W. K. Meyer and R. H. Stresau, *Initiation Times of Various Primary Explosives (U)*, Naval Ordnance Laboratory (White Oak), NAVORD Report 2644, 14 October 1952 (Confidential).
5. L. A. Rosenthal, *Electro-Thermal Equations for Electro-Explosive Devices*, Naval Ordnance Laboratory (White Oak), NAVORD Report 6684, 15 August 1959.
6. W. G. Chace and H. K. Moore, *Exploding Wires*, The Plenum Press, New York, 1959.
7. W. M. Slie, *An Insensitive Substitute for Graphite Bridge Detonators for Laboratory Evaluation of Fuze Explosive Trains*, Naval Ordnance Laboratory (White Oak), NAVORD Report 4512, 6 February 1957.
8. TM 9-1981, *Military Pyrotechnics*, Department of the Army, January 1951.
9. G. J. Bryan and E. C. Noonan, "Energy Requirements for the Ignition of Seven Solid Explosives," Proc. Royal Society, Series A, Mathematical and Physical Sciences, 246, 1245, 167 (1958).
10. R. L. Wagner, *Development of a Modified M47 Detonator Having Improved Cook-Off Characteristics*, Picatinny Arsenal Technical Report 2519, June 1958.
11. W. Slie, *A Study of Output of Detonators Versus Internal Design Factors of Limited External Dimensions (U)*, Naval Ordnance Laboratory (White Oak), NAVORD Report 3593, 10 December 1953 (Confidential).
12. P. F. Mohrbach, R. F. Wood and N. P. Faunce, *Development of an RF Attenuated T24E1 Detonator (U)*, The Franklin Institute Report LM-A2357-7, Contract DA-36-034-501-ORD-3115 RD, June 1, 1961 (AD-347 806) (Confidential).
13. J. F. Heffron and P. F. Mohrbach, *Automatic Bridging Mechanism for Electric Detonators (U)*, The Franklin Institute, Report F-A2352, Contract DA-36-034-501-ORD-3107 RD, May 1961 (AD-326 667) (Confidential).

## CHAPTER 6

### DELAY ELEMENTS

#### A. DESCRIPTION

##### 57. Function and Construction

Many tactical situations call for the introduction of a time delay between an input stimulus and firing. A variety of mechanical and electrical devices has been employed to delay the firing of explosive materiel.<sup>6</sup> However, we are concerned here with the prolongation of the burning phase to provide this delay. As pointed out in Paragraph 17, burning forms an important part of the growth of detonation. Hence, it is one of the simplest means for providing delay. It is usually desirable to interpose a column of a special delay material in which the rate of burning is more readily controlled than in material predisposed to the growth of explosion. Since burning rates are affected by such conditions as pressure and temperature and their gradients, it is necessary to take these effects into consideration when designing initiators for delay columns and selecting inert components in which they are housed.

In its barest essentials, a delay element is a metal tube with an initiator (a primer) at one end (see Paragraph 45), a delay column in the middle and a relay or other output charge at the other end. In addition, depending upon the application and the delay material used, the element may include baffles, igniter mixes at one or both ends of the delay, a housing and provision for internal free volume. Delay elements are subdivided according to construction into the two main divisions of obturated and vented.

##### 58. Delay Types

*a. Obturated Delays.* Obturated delay elements are so constructed as to retain all gases emitted by the initiator and the delay element until the relay or other base charge explodes. This class includes also the so called "internally vented" delays.<sup>1</sup>

Advantages of obturated delays include the inherent independence of these necessarily well sealed units from effects of pressure or humidity of the ambient atmosphere, and the absence of fumes which might have harmful effects on other components of a system. Obturation also helps in the design of short delays because the resulting increase in pressure increases the burning rate.

(1) *Percussion Initiated.* The principal use of percussion primers in explosive trains is for the initiation of delay elements. In this application, their main advantage over stab primers is their adaptability to obturated systems. A typical percussion initiated obturated delay system is shown in Figure 40.<sup>4</sup> Note the heavy construction, to contain the pressure, and the expansion chamber. Some delays contain baffles beyond the primer to prevent erratic delay times caused by penetration of the delay column by hot primer particles, erosion by the action of the gas stream or cracking by the shock wave.

(2) *Electrically Initiated.* Some electrically initiated obturated delay elements are essentially the same as percussion initiated items with electric initiators in place of the percussion primers. Others are military adaptations of commercial delay blasting caps. The MARK 35 detonator (Fig. 41<sup>4</sup>) is an example of such an adaptation. The delay powder is loaded, at bulk density, into a lead tube of larger than the intended finished diameter. The tube is then drawn to size, consolidating the explosive.

In the electric delay detonator T65 (Fig. 42<sup>2</sup>) advantage is taken of the small size of spotting charges of recently developed electric initiators and of the modern gasless delay compositions to eliminate baffle and air space. There may be some question as to whether the T65 remains obturated throughout its delay period because the gas produced is enough to cause high pressures. Occasional fast times observed during development of T65

detonators indicate that those which have satisfactory delay times do so only because they leak. However, the advantage of a sealed unit in storage is realized.

*b. Vented Delays.* Vented delays have openings through which gases may escape. As delays become longer, the amount of gas they produce and consequently the internal volume needed in an obturated delay element increases to a point where the units become too bulky. In practice, before this point is reached, vented delays are used. These designs are usually more reproducible in functioning time than obturated delays because the tolerances in internal volume, size of priming charge and gaseous impurities in the delay element have a cumulative effect of varying pressure and, hence, burning rate of the delay columns of obturated items.

Vents must be kept closed until the devices are fired to protect primer and delay column from moisture and other atmospheric deterioration. Figure 43<sup>a</sup> shows two means for sealing vents, (a) covering them with disks, and (b) providing a soft plug to blow out under the action of the primer.

*c. Ring Type Delay.* The ring type delay is a special type of vented delay and is therefore discussed separately. The delay consists of a column of black powder which is wound through the fuze cavity (Fig. 44<sup>a</sup>). The ring type delay is generally so large as to comprise a large part of a fuze. The delay time of the M54 fuze can be set at any desired value from 0.4 to 25 seconds by rotating the calibrated ring, thus varying the length of the delay train which must be traversed by the flame between the primer and the output charge.

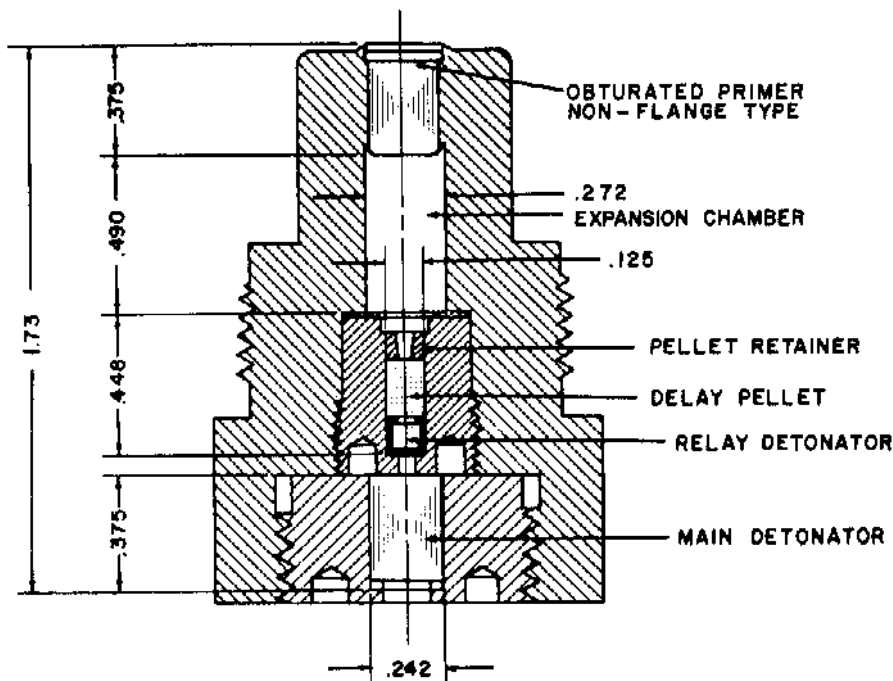

Figure 40. Obturated Delay Element of Bomb Fuze ANM100A2

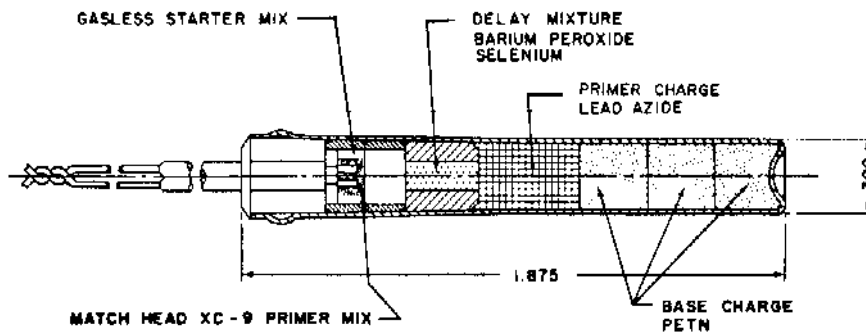

Figure 41. Electric Delay Detonator (MARK 35 MOD 1)

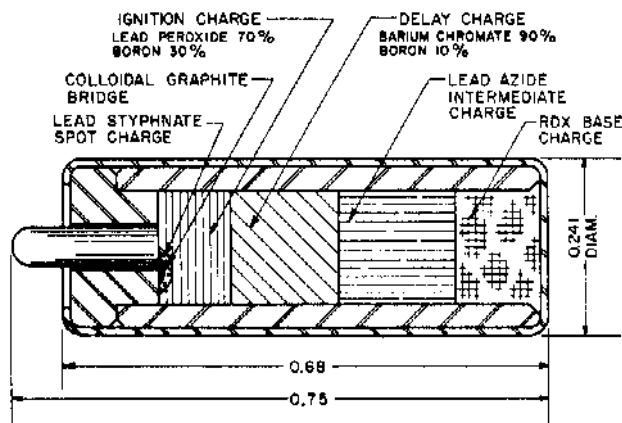

Figure 42. Electric Delay Detonator (T65)

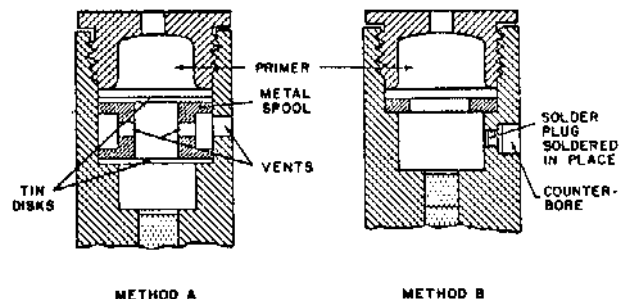

Figure 43. Sealing Methods for Vented Delays

d. *Delays Achieved by Methods Other than Controlled Rate Burning.* Ignition of one charge by another may be delayed by control of the heat transfer process. An experimental design in which primer and output relay were separated by a baffle with relatively small ports, to delay initiation of the relay until sufficient gas has passed through the ports, was not successful.<sup>4</sup>

The pressure evolved by burning black powder can be utilized to give delays in the order of one to six milliseconds. The principle involves a rapid build-up in pressure and terminates in the rupture of a disk. Designs based on this principle can be vented or obturated. Figure 45<sup>a</sup> shows a delay based on this principle, using a vented type with baffle.

## 59. Relays

The output charge of a delay element is usually a relay. The relay can consist simply of the last charge increment in the delay element, or it can be a separate component inserted into the delay assembly. As separate components, relays are also used in other parts of the explosive train. Typical relays are shown in Figure 46.

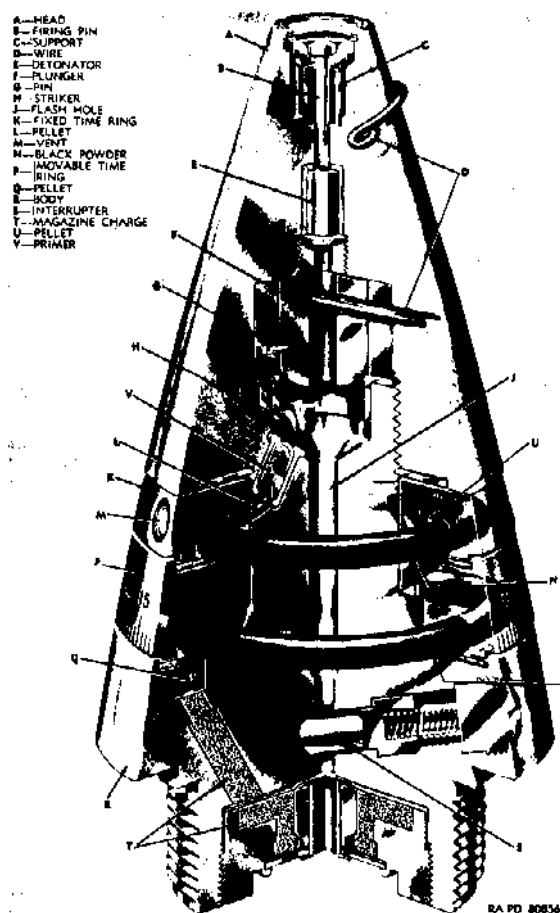

Figure 44. Fuze M54

The input characteristics are essentially those of a flash detonator (see Paragraph 49) while the output characteristics can be those of a primer or a detonator as desired (see Paragraphs 51 and 52).

The usual relay consists of a cup into which lead azide is pressed at 10,000 psi. In some relays, a sealing disk is crimped over the open end while in others, the end is left open, but the skirt left by partial filling is crimped to an angle. When such relays are inserted into delay elements and crimped in place, the crimp is compressed just sufficiently to result in a firm and snug fit.

## B. DELAY COMPOSITIONS

### 60. Gas Producing Delay Charges

a. *Loading Pressure.* Since the burning of gas producing materials depends upon the transfer of heat between the gaseous reaction products and the solid, the burning rate is a direct function of pressure. Thus, the delay times of such delays are

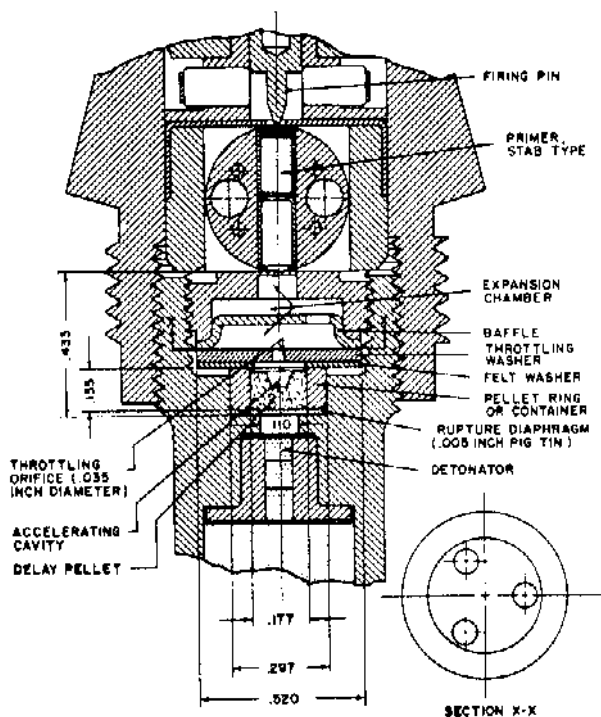

Figure 45. Pressure Type Delay

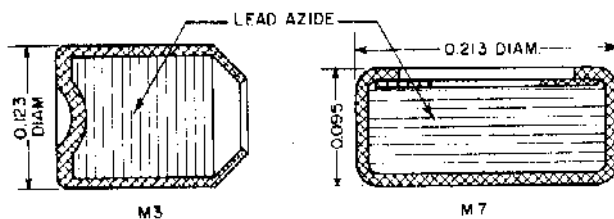

Figure 46. Typical Explosive Relays

greatly influenced by all factors which affect the gas pressure at the burning surface. The burning surface, of course, is all surface exposed to the gas, including that of pores and cracks which the gas may penetrate. The largest class of gas producing delays are black powder elements.<sup>a</sup>

Reproducible behavior of any delay requires that it burn as a continuous homogeneous substance. Porosity can result in a discontinuous relationship between interface pressure and burning rate. Black powder delays are therefore loaded at 60,000 psi or more. When a long column is required, it is pressed in increments, each pellet being no longer than its diameter (see Paragraph 95).

*b. Pellet Support.* As a gas producing delay burns, the surface in frictional contact with the walls

diminishes while (in the case of an obturated delay) the pressure increases. The point at which a cylindrical pellet would break free and initiate the relay would be determined by such random considerations as surface roughness. The time of breakthrough is made more definite by pressing an acceleration cavity in the output end of the pellet. The pellet is supported by a washer or the relay detonator cup (Fig. 47<sup>a</sup>).

*c. Effects of Moisture and Temperature.* The effect of moisture on the burning rate of black powder is quite complex. For this reason, black powder delay elements must be kept dry. Effects of temperature extremes on performance of black powder delay elements vary appreciably from one delay to another. The spread of data almost invariably increases at extreme temperatures. It may be suspected that these variations are related to subtle design details.

*d. Obturated Delays.* In an obturated system, the pressure in the enclosed free volume is increased, quickly at first, by the primer or flash charge and then progressively by the gas liberated by the burning of the delay column. The result is that the burning rate (which is usually nearly proportional to pressure) accelerates continuously. The time does not increase directly with the column length unless the free volume is also increased. This requirement for a volume more or less proportional to the delay time limits obturated gas producing delays to about 0.4 seconds with the common diameter columns of 0.1 to 0.125 inch. The delay time of an obturated delay element, in addition to its direct relationship to the free volume, is inversely related to the gas volume and heat of explosion of the primer (Fig. 48<sup>a</sup>).

If the pressure rise in an obturated system is sufficient to cause bursting or significant leakage, the time will be greatly increased or the item may not burn through. The pressure may be calculated from thermodynamic consideration of heat and gas volume liberated by the primer and delay column and the enclosed free volume in which the gases are confined. For design test purposes, the following equation gives a reasonable estimate

$$P = 30(W_p + W_d)/V \quad (36)$$

Where the pressure  $P$  is in pounds per square inch, the weights of the priming composition  $W_p$  and the delay composition  $W_d$  are in milligrams and the enclosed free volume  $V$  is in cubic inches.

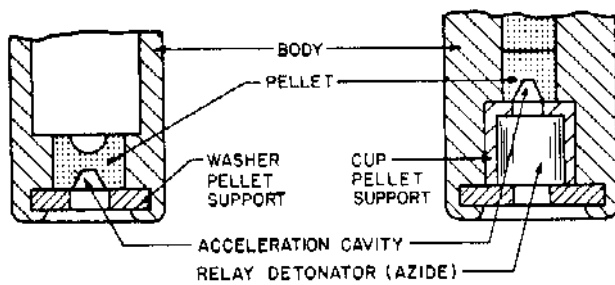

Figure 47. Support of Delay Pellet

*e. Vented Delays.* The burning rate of a gas producing material is, in general, nearly proportional to pressure. At atmospheric pressure, a vented black powder delay column 0.125 inch in diameter, pressed at 65,000 psi, burns at an inverse rate of about 5.5 seconds per inch.

When mounted in fuzes, vented delays must be located so as to vent to the outside or to a relatively large volume. If other components of the fuze also occupy the volume, account must be taken of the effects of gaseous combustion products on these components. Since the behavior of black powder is adversely affected by moisture, vents must be sealed until the delay is initiated. Two methods of sealing are shown in Figure 43.

## 61. Gasless Delay Charges

*a. Delay Compositions.* The limitations of gas producing delay compositions and the inherent problems associated with their design have led to the development of gasless delay mixes. It is possible to write stoichiometric equations for many highly exothermal reactions which produce no gaseous products. A large number of these have been considered and many subjected to experimental investigations.<sup>5-8</sup> However, most of them have been discarded for one or another of the following reasons

- (a) Erratic burning rates,
- (b) Too large column diameter necessary for reliable propagation,
- (c) Large temperature coefficient of burning rate,
- (d) Failure at low temperatures,
- (e) Hygroscopicity,
- (f) Rapid deterioration,
- (g) Unavailability of reproducible supply of raw materials,
- (h) Large pressure coefficient of burning rate,
- (i) Failure at low pressure, or

TABLE 32. GASLESS DELAY COMPOSITIONS IN CURRENT USE

Fuel	Oxidant		Inert
Boron	Barium chromate	Chromic oxide	None
4 to 11	89 to 96	—	
13 to 15	40 to 44	41 to 46	
Manganese	Barium chromate	Lead chromate	None
45 to 30	0 to 40	15 to 70	
20 to 50	70 to 40	10	None
Molybdenum	Barium chromate	Potassium perchlorate	
20 to 30	70 to 60	10	
Ni-Zr Alloy	Barium chromate	Potassium perchlorate	None
	60	14	
Ni-Zr Mix	Barium chromate	Potassium perchlorate	None
5/31	22	42	
5/17	70	8	
Selenium	Barium Peroxide	—	Talc 0.5 (added)
84	16		
Selenium	BaO <sub>2</sub>	—	Tin/lead alloy powder (15/85) 20
20	80		
Silicon	Red lead	—	Celite max. 8 parts by weight
20	80		
Tungsten	Barium chromate	Potassium perchlorate	Diatomaceous earth
27 to 39	59 to 46	9.6	5 to 12
39 to 87	46 to 5	4.8	3 to 10
Zirconium	Lead dioxide	—	None
28	72		

(j) Reaction products liquid or otherwise subject to movement from acceleration during burning.

Table 32 lists the gasless delay combinations in current use. The range of compositions given for some of the combinations allows for adjustment of the burning rates over wide ranges.

*b. Ignition Powders.* A column of gasless delay composition is usually preceded by a charge of igniter mix. Igniters are necessary when the delay compositions are too insensitive to be initiated directly by the agent used in the particular application. Table 33 gives the compositions of igniter mixes used in gasless delay elements.

TABLE 33. IGNITION POWDERS FOR GASLESS DELAY ELEMENTS

Fuel	Oxidant	Inert
Boron (30)	Lead peroxide (70)	—
Boron (10)	Barium chromate (90)	—
Zirconium (41)	Ferric oxide (49)	Diatomaceous earth (10)
Zirconium (65)	Ferric oxide (25)	Diatomaceous earth (10)
Zirconium (33)	Ferric oxide (50)	—
Titanium (17)		

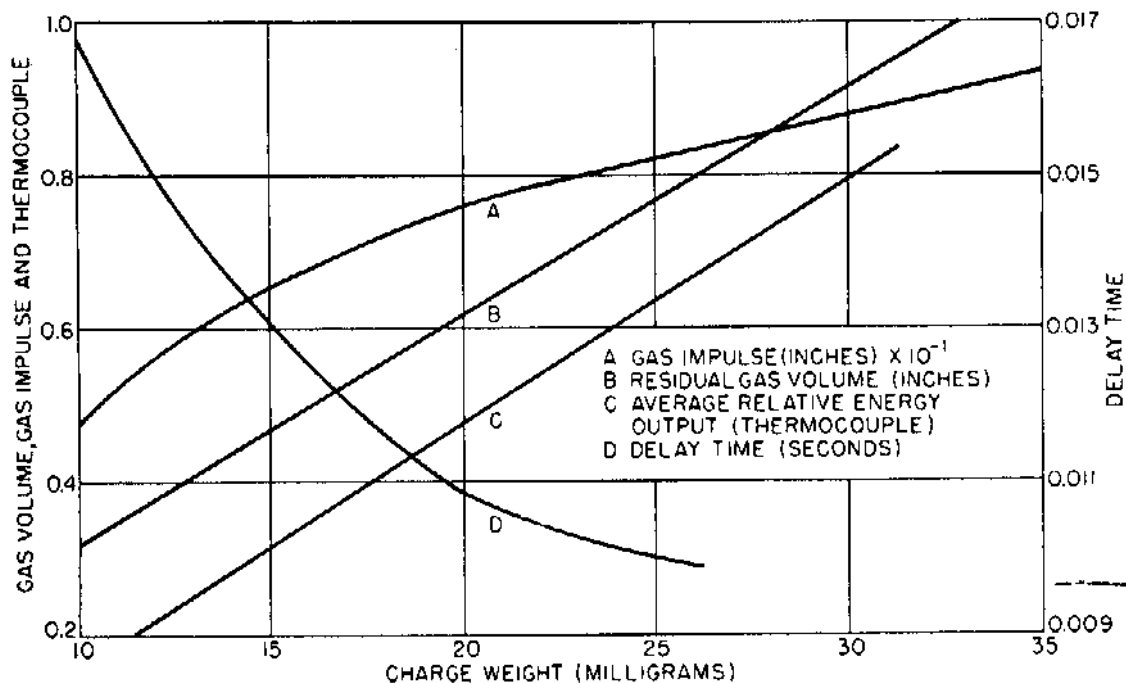

Figure 48. Characteristics of an Obturated Black Powder Delay Element

Note that these are all gasless mixtures which also have application as gasless delay mixtures. They differ from the mixtures of Table 32 in that they burn faster and are readily ignitable.

*c. Properties of Delay and Ignition Powders.* In addition to burning rates, properties of delay powders of interest include variability of burning rate, temperature coefficient of burning rate, pressure coefficient of burning rate, effects of storage (both wet and dry), effects of column diameter and obturation and mechanical properties. Other special problems may be associated with the use of one or another type of composition. Before discussing these properties, it should be stressed that they are affected by such variables as particle size, particle size distribution, intimacy and uniformity of mixture, relative distribution of components of a mixture, and impurities which are not readily detectable. To control these variables, relatively elaborate procedures have been established for the procurement, characterization and treatment of raw materials, and the mixing and subsequent treatment of the ignition, and delay powders. It should not be assumed that similar properties will be observed in all mixtures of the same nominal chemical composition. The description of the compounding of delay compositions is beyond the scope of this handbook.

(1) *Burning Rates.* Table 34<sup>a</sup> gives the ranges of burning rates of current gasless delay compositions. The variation of burning time within a lot of delay elements is expressed as a *coefficient of variation*, the standard deviation of the burning time expressed as a percentage of the total burning time. Under controlled laboratory conditions, the coefficients of variation of most of the materials listed are three percent or less.

Lot-to-lot variability may be compensated by adjusting the length of the delay column for each new lot of delay composition or by adding appropriate ingredients and remixing to speed up or slow down the mixture. Variation may be greatly reduced by careful control of raw materials and preparation procedures.

Coefficients of variation as small as three percent cannot be expected in practical delay elements. Variations in other components than the delay column contribute to the variability. In general, these other variations affect the shorter delays most seriously.

(2) *Effects of Temperature and Storage.* Since the burning of a pyrotechnic delay composition is essentially a heat transfer process and since the peak temperatures are lower than those of most explosive reactions, it is to be expected that temperatures of  $-65^{\circ}\text{F}$  to  $+125^{\circ}\text{F}$ , the usually



TABLE 34. BURNING RATES OF GASLESS DELAY COMPOSITIONS

Composition*	Designation	Approximate Inverse Burning Rate (sec/in)
BaCrO <sub>4</sub> /Cr <sub>2</sub> O <sub>3</sub> /B 44/41/15	-	4.5-8.5
44/42/14	-	4.5
41/44/13	-	6.5
BaCrO <sub>4</sub> /B (amorphous)	-	8.5
(crystalline)	-	0.5-3.5
95/5	-	9-12.5
90/10	-	1.5
BaCrO <sub>4</sub> /KClO <sub>4</sub> /W 40/10/50	-	0.6
70/10/20	-	12.5
BaCrO <sub>4</sub> /KClO <sub>4</sub> /(Zr-Ni)(alloys)	-	41
60/14/9(70-30)/17(30-70)	Type II	3-11
60/14/3(70-30)/23(30/70)	Type III	6
BaCrO <sub>4</sub> /PbCrO <sub>4</sub> /Mn	D-16	11
0/45/55	-	2.5-12.5
30/33/37	-	2.17
30/33/37	-	9.45
BaO <sub>2</sub> /Se/Talc	-	16.58
84/16/0.5 added	-	2.3
Red Lead/Si/Celite	-	4-11
80/20/3 to 7 added	-	4-11
PbO <sub>2</sub> /Zr 28/72	-	<0.5
Zr/Ni/BaCrO <sub>4</sub> /KClO <sub>4</sub> 5/31/42/22	T-2	6.5
5/17/70/8	HP-25	17.8

\*Numbers given are percentages

specified operating range of military materiel, should have a significant effect. In general, the effect is more than is desirable, experimental results ranging up to 25% variation.

A number of delay compositions have been stored at both high and low humidity.<sup>9</sup> All those tested survived the low humidity storage without failure whereas a number of mixes failed after high humidity storage. It was concluded that the mixes will survive storage in well sealed packages. Effect of surveillance on burning rates was inconsistent, some mixes slowing down 6% while others accelerated up to 30%. It is not clear whether the tests demonstrated the effectiveness of the seal or the moisture resistance of the delay composition.

(3) *Effects of Reduced Pressure.* In some applications, vented delay systems are required to operate at high altitudes. Many compositions are affected appreciably at low pressures. Some of the slower mixes with crystalline boron, for example, couldn't be initiated at pressures less than 50 to 200 mm. One molybdenum mix at 40 mm, the lowest pressure at which it would ignite, doubled its burning time as compared with normal atmospheric conditions.

(4) *Effects of Acceleration.* Delay elements are often subjected to very high accelerations while the delay composition is burning. If the structure of the material at or behind the reaction front is too weak, the accelerations may cause the hot products to lose contact with the unburned delay composition or a subsequent charge, and extinguish the reaction.

Although quantitative data regarding the resistance of delay compositions to this type of failure are not available, the "slag retention," the fraction of the weight of the original charge remaining in an open ended delay column after functioning, has been used as a qualitative indication of this property and the relative gaslessness of the composition. Slag retentions are in the following descending order: D-16, >95%; Red lead, 90%-95%; HP-25, 90%; tungsten, >88%; Ni/Zr, 80%-90%; Boron, 50%-90%.

(5) *Particle Size.* The effect of particle size on the inverse burning rates of delay compositions is nearly direct. In addition to increasing the burning rate (faster burning), reduction of the particle size tends to reduce the effects of temperature and pressure.

*d. Design, Fabrication, and Loading.* An ideal delay composition would be a material which, once ignited, would burn at a uniform rate which is independent of all surrounding conditions. This ideal has not been attained. Reasonable performance of a delay element demands that the design take into account the effects of various conditions upon the behavior of the composition.

(1) *Loading Pressure.* Data relating burning rate to density for barium chromate/boron compositions are given in Table 35. Similar results will not necessarily be found with other compositions. The rather small and systematic change of burning rate with loading pressure suggests that considerable latitude is available to the designer and that adjustment of pressure might be a convenient way to compensate for lot-to-lot variations in burning rate. However, considerations of ruggedness have resulted in the practice of loading gasless delays at pressures between 30,000 and 40,000 psi. In this respect, it should be borne in mind that a crack in a delay column can result in a "blow through" and instantaneous functioning. For best results, delay columns and igniter charges should be loaded in increments not over one-half diameter long.

(2) *Column Diameter.* Radial losses of heat can retard or extinguish the burning of a delay column. Such losses, of course, become more serious as the

TABLE 35. EFFECT OF LOADING PRESSURE ON BaCrO<sub>4</sub>-B COMPOSITIONS

95/5 BaCrO <sub>4</sub> -B	Loading Pressure (10 <sup>3</sup> psi)					
	36	18	9	3.6	1.3	0.5
Mean burning rate (sec/inch)	1.69	1.60	1.49	1.39	1.29	1.21
Mean burning rate (sec/gram)	0.648	0.655	0.645	0.642	0.646	0.693
% Coefficient of Variation	1.2	0.6	0.7	0.7	0.8	0.8
90/10 BaCrO <sub>4</sub> -B						
Mean burning rate (sec/inch)	0.670	0.653	0.619	0.586	0.558	0.544
Mean burning rate (sec/gram)	0.272	0.276	0.280	0.287	0.297	0.309
% Coefficient of Variation	1.5	0.9	1.1	1.6	2.0	1.8

column diameter, burning rate and ambient temperature are reduced, and these effects combine to result in a failure diameter associated with delay mix and temperature. For the manganese compositions at -65°F, the failure diameter for a three second/inch composition is less than 0.109 inch; that of a ten second/inch mix is between 0.125 and 0.156 inch, while for a 12.5 second/inch composition, the failure diameter is between 0.156 and 0.203 inch. It is believed that for practical delay mixtures and at -65°F, the quarter-inch diameter usually used is well above the failure diameter.

(3) *Wall Thickness.* The body into which a delay is loaded serves as a heat sink. Metals in general are much better conductors of heat than is the delay composition. Delay columns close to their low temperature failure diameters tend to have larger thermal coefficients as the surrounding wall thickness is increased. For materials well above their failure diameters, the effect of wall thickness becomes less important. It has been suggested that a body with very thin walls of a good thermal conductor might accelerate burning by preheating the column ahead of the burning front.<sup>10</sup>

The strength of the delay body can be important. Yielding under the loading pressure has been found to result in erratic delay times.<sup>11</sup> Stress analysis of the body as a tube stressed hydraulically is a conservative means of assuring adequate strength. However, experience indicates that delay bodies will usually give satisfactory results under conditions such that calculated stress is well beyond the yield point.

### C. DESIGN PRINCIPLES

#### 62. Obturated vs. Vented Design

The harmful effects of moisture and other atmospheric gases make sealed delay elements desirable in all cases and mandatory for situations where an element which must be exposed to normal

storage and handling conditions contains materials which fail after humid surveillance. Obturated delays are inherently sealed.

Delay powders are divided into two categories, those whose reaction products are largely gaseous, and those known as gasless. All current design effort has been applied to the latter which lend themselves to obturated design.

The term gasless must not be taken literally. Gasless delay compositions produce some gas, chiefly as a result of impurities. Gas quantity is much less predictable than that of gaseous delays. For this reason, it is the best practice to use an internal volume large enough so that the effect of pressure build-up on the delay time is negligible. This is quite practical in relatively short delays. However, as the length, and consequently the amount of delay powder increases, the required free volume also increases, so a delay element can get quite bulky. Such considerations often drive the designer to the use of a vented system.

#### 63. Design Rules of Thumb

Because delay compositions are metastable materials containing all ingredients necessary for self propagating reaction, their burning is metastable. The effect of any factor which tends to cause an increase or decrease in burning rate is exaggerated. For this reason, satisfactory performance requires accurate control of all such factors. Control must be maintained from the procurement of raw materials until the weapon, of which the delay is a component, reaches its target. The following rules should govern the designer

(a) Use delay compositions prepared by a well established procedure from ingredients of known and controlled characteristics.

(b) Use obturated or internally vented construction where practical.

(c) Where obturated construction is impractical, use a seal which opens at ignition.

(d) If a sealed unit is not practical, use delay compositions of demonstrated resistance to conditions of high humidity.

(e) Calculate the effect of cumulative tolerances upon such pertinent factors as internal free volume.

(f) Provide for adequate free volume in obturated units.

(g) Analyze stresses induced by both internal and external forces which may be anticipated during loading, shipping, launching and operation.

(h) Make sure that all components will survive

these stresses taking into account the elevated temperatures which result from burning of the delay column.

(i) Specify adequate loading pressures (at least 60,000 psi for gas producing compositions and at least 30,000 psi for gasless delay powders), and short enough increments (one-half diameter).

(j) Provide for proper support of delay column.

(k) Use diameters well above failure diameter at  $-65^{\circ}\text{F}$ . (Usual practice is 0.2 or 0.25 inch for gasless mixtures; 0.1 or 0.125 inch for black powder.)

## REFERENCES

### CHAPTER 6

*a-i Lettered references are listed in Paragraph 12 (end of Chapter 1).*

1. H. S. Leopold and E. E. Kilmer, *An Investigation of Internal Venting for Delay Actuators*, (U), Naval Ordnance Laboratory (White Oak), NAVORD Report 5724, 10 September 1957 (Confidential).
2. D. E. Seeger and R. E. Trezona, *Development of the 50 Millisecond-Delay T65 Electric Detonator* (U), Picatinny Arsenal Technical Report 2594, April 1959 (Confidential).
3. TM 9-1300-203, *Ammunition for Antiaircraft, Tank, Anti-tank, and Field Artillery Weapons*, Department of the Army, August 1960.
4. J. Squier and L. Zernow, *Short Delay Baffle Detonators for Antiaircraft Contact Fuzes*, Aberdeen Proving Ground, BRL Report 690, February 1949.
5. David Hart, *Long-Range Development of Delay Powders for Ammunition Fuze Application*, Picatinny Arsenal Technical Report 1733, 7 June 1949.
6. Burton Werbel, *Development of Delay Powders*, Picatinny Arsenal Technical Report 2249, September 1955.
7. R. Comyn and R. Dwiggin, *Surveillance Characteristics of Gasless Igniters*, Naval Ordnance Laboratory (White Oak), NAVORD Report 1774, 14 March 1951.
8. *Effect of Loading Variables on the Burning Characteristics of Delay Powders*, Naval Ordnance Laboratory (White Oak), NAVORD Report 2262, December 1951.
9. M. F. Murphy, *A Comparative Study of Five Pyrotechnic Delay Compositions*, Naval Ordnance Laboratory (White Oak), NAVORD Report 5671, 2 April 1958.
10. B. A. Breslow and R. K. Blanche, Sr., *Development of a Short-Time Interval Fuze Delay Element for 2.75-inch Folding Fin Aircraft Rocket*, Naval Ordnance Test Station, NAVORD 3333, May 1954.
11. E. E. Kilmer, *The Development of the XE-57B Delay Primer for the Picket Boat Depth Charge Pistol* (U), Naval Ordnance Laboratory (White Oak), NAVORD Report 6092, 13 October 1958 (Confidential).

## CHAPTER 7

# LEADS AND BOOSTERS

### A. DESCRIPTION

#### 64. General

Leads and boosters are those components of the explosive train whose function is the transmission of the detonation established by the detonator and its augmentation to a level such that the main charge is initiated reliably. They are the most flexible tools of the explosive train designer and they are the components most influenced in operation by his decision regarding the design of inert parts. They are relatively simple in function and fabrication.

The explosive contained in a booster is called a booster charge. In common usage, the term *booster charge* is abbreviated to *booster*. Actually, a booster consists of a housing and other metal parts, the booster charge and, as a special feature, an auxiliary arming device. We are concerned here only with booster charges.

Figures 49 to 51 are sectional views of typical military items which illustrate the use of leads and boosters. Figure 49<sup>1</sup> shows a complete booster, the M21A4, which is employed with point detonating fuzes to effect the functioning of projectiles. It is typical of boosters used in artillery projectiles. The external threads screw into the projectile so that the booster rests in the fuze well. The internal threads hold the nose fuze, one of the M48 family.

The booster consists of two parts which thread together, (a) the booster charge *N* (a tetryl pellet) held in the aluminum booster cup *M* and (b) the brass housing *A* which contains detonator *E*, lead *L*, and a rotor as well as a variety of pins and springs which make up the auxiliary arming device. It is the purpose of the auxiliary arming device to prevent initiation of the booster in the event of a premature functioning of the fuze detonator. When armed by setback and centrifugal forces of firing, the booster detonator moves into line with the fuze

detonator. The explosive train is then complete so that the detonator in the fuze initiates the booster detonator which in turn sets off lead and booster charge.

Figure 50<sup>2</sup> illustrates the use of boosters in spit-back systems. Two booster charges are required for this application, the donor (auxiliary booster) at the end of the fuze explosive train and the receiver (booster) at the bottom of the projectile cavity. Operation of this fuze is discussed in Paragraph 71.

Finally, Figure 51<sup>3</sup> shows a typical small caliber fuze with booster charge. Because of the compactness of the 20mm fuze, no lead is required. When the fuze is armed, the firing pin initiates the detonator which sets off the booster directly. This figure illustrates that booster design is not hard and fast. Here the booster acts as a lead while the top-off charge loaded into the projectile acts as a booster (see also Figure 1).

#### 65. Functions

*a. Leads.* In some constructions, the separation between detonator and the next charge may be short, while in others, the detonator is mounted remotely from the booster. A lead is used to transmit the detonation from detonator to booster when the gap is too large for direct transmission. Leads are also used when complexity or safety of the train demands them. These various circumstances have resulted in the evolution of a wide variety of leads. Some are simple cylindrical charges of relatively small length-to-diameter ratios and others are quite long. Some transmit detonation around corners or angles and others are flexible.

While the function of a lead is merely the transmission of a detonation, in practice leads are often used to augment the output of detonators. This is done because, for reasons discussed in Paragraphs 24 and 25, boosters are generally

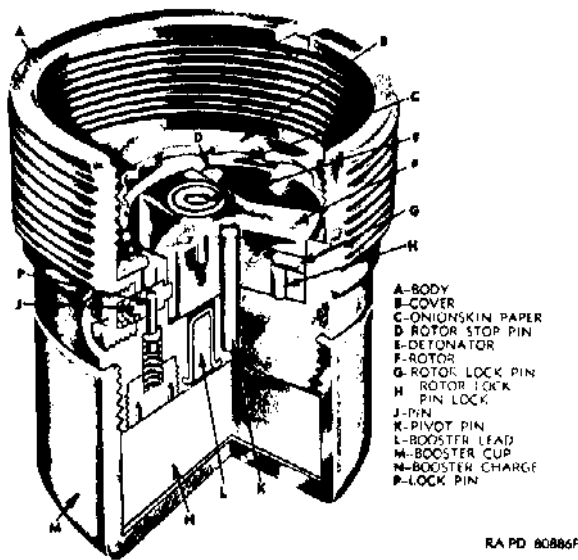

Figure 49. Booster (M21A4)

harder to initiate than leads and because leads are often called upon to initiate subsequent charges across large gaps or through heavy barriers. On the other hand, it is possible to design detonators with output adequate for the direct initiation of boosters, even where gaps are appreciable. In fuzes for small arms, leads are usually not necessary (see Fig. 5).

*b. Boosters.* The main charges of high explosive material are as insensitive as it is practical to make them. Detonators and leads are as small as is consistent with reliability. In general, neither detonators nor leads are in themselves sufficient to initiate main charge explosives reliably. Boosters are elements of sufficient output to detonate main charges reliably when initiated by detonators or leads. Hence, the main function of the booster is to augment the detonation wave.

Generally, boosters are loaded with the same or similar explosives to those used in the base charges of detonators and in leads. Therefore, their intensity as characterized by velocity of propagation, pressure, temperature and particle velocity is not distinguished from that of detonators and leads. However, since the booster charge is larger, its output is correspondingly greater. The function of a booster is to establish in the main charge a detonation wave whose dimensions are large compared with the reaction zone length of the main charge explosive material.

## 66. Explosives

For many years tetryl was the standard lead and booster explosive. It is still in more common use in leads and boosters than any other explosive. In recent years, the use of other explosives (particularly RDX and some of its mixtures) has been found advantageous for some applications. Many of the principal rules of thumb, practices and procedures which serve as guides in the design and loading of explosive components and systems derive in part from the properties of tetryl. For this reason, tetryl has served as a standard of comparison for booster explosives and the development of some materials has been a deliberate effort to match its properties.

An essential feature of any military explosive item is the safety provision of the fuze. This feature would lose its purpose if the sensitivity of the leads and booster were not limited. On the other hand, the booster must be sensitive enough to detonate reliably when initiated by means of a detonator or explosive lead. Thus, maximum and minimum allowable limits of sensitivity must be closer to-

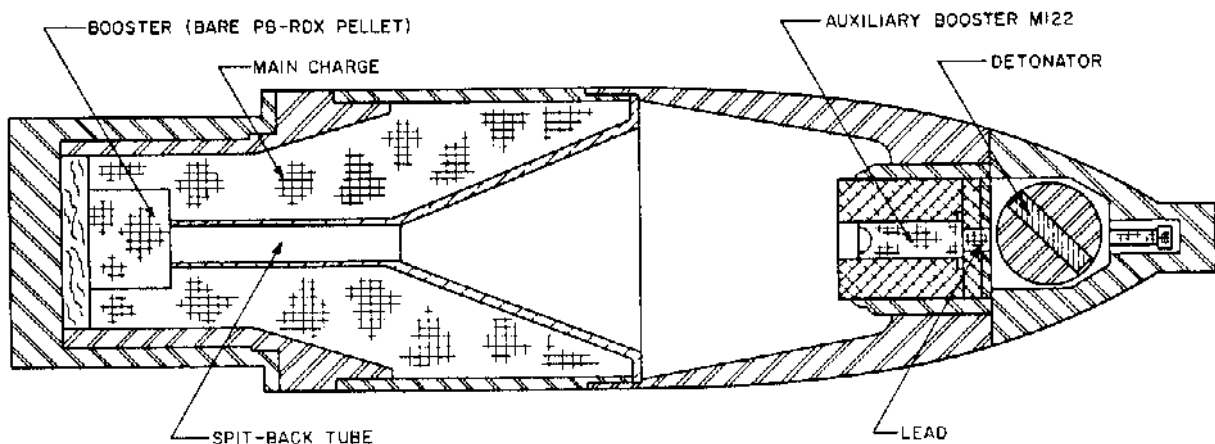

Figure 50. 2.75-in. HEAT Rocket with Spit-Back Explosive System

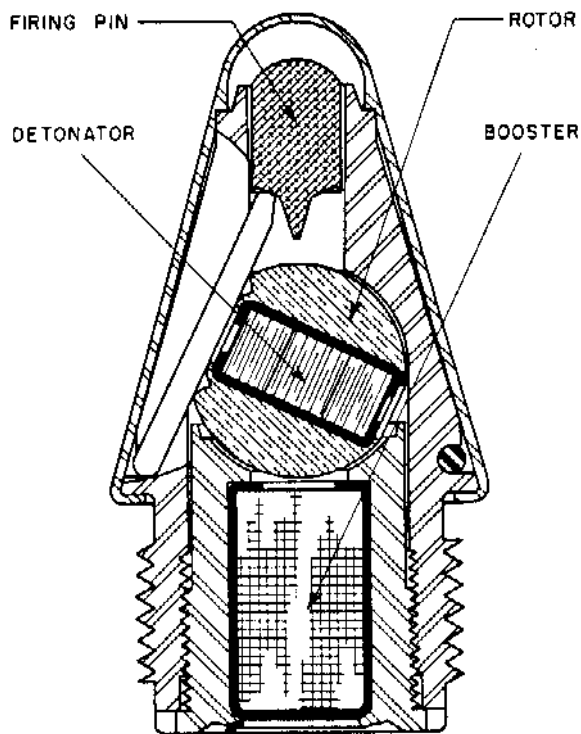

Figure 51. 20mm Fuze (M505)

gether for lead or booster explosive than for other explosives. Considerations of design economy and of safety and reliability determinations tend to compress these limits still further.

The explosive material used in the booster is somewhat more sensitive than the main charge, is smaller than the main charge and is less sensitive than the previous explosive components. It should be remembered that initiation sensitivity is a function of a number of variables of the experimental system including the agency of energy transfer, the confinement of the explosive elements, the state of aggregation of the explosive and the dimensions of the explosive elements. The effects of these variables interact to make quantitative prediction difficult unless the experiment is a reasonably accurate simulation of the conditions of use. Fortunately, the design and loading practices for leads and boosters are well enough standardized that a relatively modest test schedule can be devised to include conditions representative of all but highly specialized applications.

Table 13 is a list of the sensitivities of various booster explosives as measured by several techniques. For comparison, a few typical main charge explosives have been included. Note that the presence of one or two percent of calcium stearate or wax has an adverse effect upon the sensitivity of

RDX to initiation. Some designers have considered these materials only as binder-lubricants for the improvement of loading properties, overlooking their effects upon sensitivity. For this reason, notations appear in drawings or specifications indicating that "up to 1 percent" of these materials *may* be added. The variation allowed by such notations can result in a change in gap sensitivity by a factor of three or four. This is sufficient to make the difference between a highly reliable system and one which is almost completely inoperable.

In choosing an explosive material for a booster, both the design of inert parts and special environmental conditions associated with the application must be considered. Sensitivity and output of explosives may be adjusted by varying their loading densities. Thus, in some applications, substitution is possible, without adverse effects upon established safety or reliability levels if the designer is free to specify the loading density of the substituted explosive. However, the loading pressure needed to attain the necessary density may exceed the strength of the container. On the other hand, if the necessary density is too low, the explosive may be subject to breakage, crumbling or to other mechanical failure.

The need to consider cook-off and thermal decomposition at high temperatures is obvious. In the case of leads and boosters, the effects of temperature extremes upon explosive properties, in particular upon sensitivity, may be more serious than in other explosive charges. As is shown in Paragraphs 36-38, these effects can be quite large. In these respects, RDX and many of its mixtures, particularly when plastic bonded,<sup>3</sup> are markedly superior to tetryl.

Most boosters are pressed as pellets. Tetryl has highly desirable properties for these purposes. It flows freely through the hoppers of automatic pelleting machines (in particular if one or two percent of graphite or a stearate are added) and, when loaded at the usual 10,000 psi, forms a pellet sufficiently firm and strong to withstand the handling necessary between pelleting and insertion in the booster cup. Pure RDX, on the other hand, forms low density, crumbly, pellets when pressed at this pressure, and, at high pressures, the pellets are so brittle that they often break as they are pushed from the die. RDX Class C was developed to alleviate this difficulty, which may be further reduced by the addition of one or two percent of a binder-lubricant.

Polystyrene bonded RDX (PB-RDX) was originally intended as a compound for hot molding as a plastic. However, it can be press loaded at ordinary room temperatures like other powdered explosives. When so loaded, its physical properties, although not as good as those of hot molded PB-RDX, are definitely superior to those of almost any other pressed powdered explosive. The sensitivity of PB-RDX, when pressed at similar pressures, is almost identical with that of other booster explosives, while its output closely resembles that of tetryl. Improved physical properties and output can be obtained by hot pressing, higher loading pressures, or both, but at the expense of somewhat reduced initiation sensitivity.

## B. DESIGN CONSIDERATIONS

### 67. Relation to Fuze Design

As fuze components, dimensions of leads and boosters are largely determined by the necessities of fuze design. Similarly, the mechanical design of the fuze in which it is used is one of the important governing factors in the confinement afforded an item of this type. The fact of the matter is that the design of leads and boosters interacts with the mechanical design of fuzes to such an extent that the most practical arrangement is usually that in which these items are designed by the fuze designer.

The design of leads and boosters is not as complex as that of initiators. For this reason, many past designs have been evolved by copying a previous design which served its purpose satisfactorily. There is nothing wrong with such an approach provided improvements are added when possible, care is taken not to perpetuate errors and due consideration is given to safety and reliability. Since lead and booster layout and materials affect other fuze design features to a large extent, it is best to give them careful consideration in early design stages before major dimensions are frozen. In the case of leads, standards have been established for dimensions and cups.<sup>c</sup>

### 68. Leads

*a. Length.* When a lead is initiated by a detonator or another lead with a metal covered output end, some increase in the reliability with which it will be initiated may be attained by reducing its length to allow for a gap at its receiving end. Where it has a closure at the output end, a small gap at this end

may also increase the reliability with which it will initiate the succeeding element. Although a number of investigators have noted that detonation is more effectively transmitted by moving fragments than by shock, flame, or even by the direct contact of detonating explosive, the permutations of variables are so numerous as to have discouraged a quantitative study of their interactions to affect reliability. Optimum gaps between detonators and leads ranging from 0.03 inch to 0.125 inch have been observed.

Where a lead is used to augment the output of a relatively mild detonator or where it is initiated for use under adverse conditions such as across a large gap or through a heavy barrier, it may be necessary to make leads longer than they would be just for transmission. It has been found that the output of a lead which detonates high order for most of its length reaches a point of diminishing returns when the length is about four or five diameters or more. The growth of detonation in marginally initiated leads has been observed to take place over as many as fifteen diameters but the reproducibility of this process is not well enough established to be relied upon, even if systems involving such gradual growth in leads had attractive design possibilities. At the present state of the art, the only valid reason for use of a lead more than four diameters long is the necessity arising from the mechanical separation of the components which it connects.

*b. Diameter and Confinement.* The most usual combination of lead diameter and confinement in military usage is an explosive column between 0.150 and 0.160 inch diameter, heavily confined in brass or steel. Figure 49 is an example of such a design. Failure diameters are listed in Table 36.

As is indicated in Paragraph 25, the most reliable transmission of detonation between a detonator and a confined lead occurs when the lead is close to the same diameter or slightly smaller in diameter than the detonator. Since a common diameter of detonators in military use is 0.192 inch O.D. and about 0.172 inch I.D., the prevalent lead diameter is well chosen from this point of view.

The effect of lead diameter upon lead sensitivity is not usually of practical significance in the design of military materiel. Where it is, present practices are close to ideal.

The importance of diameter and gap to sensitivity is illustrated for idealized acceptors similar to leads in Figure 12. Effect of gap and confine-

TABLE 36. FAILURE DIAMETERS OF LEAD AND BOOSTER EXPLOSIVES (INCH)

Explosive	Bare	Confinement				
		Fabric (Detonating cord)	Lucite <sup>a</sup>	Aluminum <sup>b</sup> (0.006 walls)	Lead (MDF)	Heavy Brass or Steel <sup>c</sup>
PETN	—	0.06	—	< 0.05	< 0.01	< 0.05
RDX	—	—	—	—	< 0.02	—
RDX/Calcium Stearate 98/2	—	0.14-0.17	—	0.08-0.12	—	—
Tetryl	< 0.50	—	—	0.10-0.13	—	< 0.08
TNT (Granular)	0.50-0.70	< 0.63	0.50	—	—	< 0.10
TNT (25 μ)	—	—	< 0.10	—	—	—

<sup>a</sup> Ref. 4  
<sup>b</sup> Ref. 5  
<sup>c</sup> Ref. 6

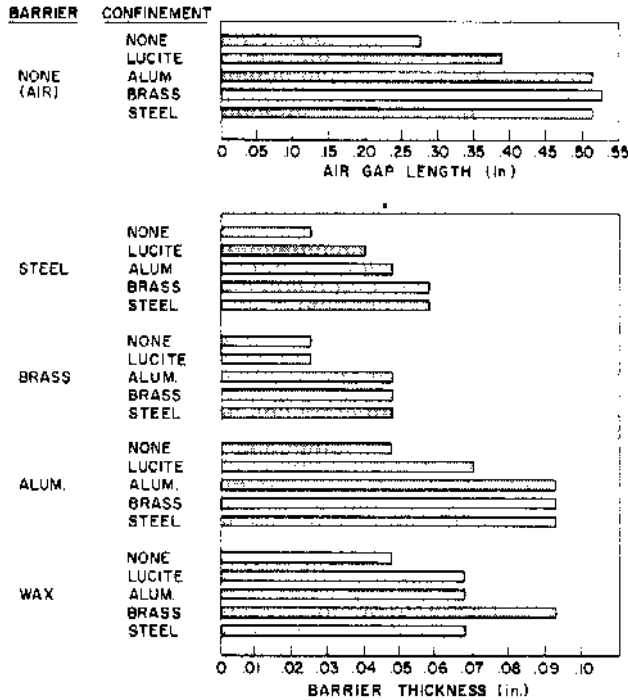

STEEL DENT OUTPUT TEST WITH Tetryl LEADS, 0.169 INCHES O.D. TUBE DETONATORS IN GROUPS OF 30. MINIMUM DENT FOR HIGH ORDER DETONATION IS 0.015 INCHES

Figure 52. Critical Conditions for Detonation of Lead

ment for actual service leads on initiation by detonators is shown in Figure 52.

The effect of the wall thickness of a confining tube upon the initiation sensitivity of leads or similar small columns, has not been quantitatively evaluated. In one experiment with 0.169-inch diameter leads, there was no significant difference resulting from confinements between 0.500 inch and 12.25 inch O.D.

An important aspect of lead confinement is the effect of clearance between the lead cup and the hole in which it is inserted. By resisting radial expansion, the confining medium directs a larger fraction of the energy along the axis toward the booster. In an experiment with a standard lead of

0.171 inch nominal diameter, three groups were tested under identical conditions except for clearance.<sup>7</sup> Of those with a snug fit, ten out of ten fired high order; of those with 0.004-inch diametral clearance, only four fired high order while all ten with 0.008 inch clearance failed. In view of these results, the designer has the following alternatives

- (a) Call for force fits of leads,
- (b) Load the cup in place. (This procedure is of value only when the loading pressure is substantially beyond the yield pressure of the cup), or
- (c) Evaluate reliability on the basis that only the lead cup provides confinement, and safety on the basis that the lead is well confined.

The foregoing remarks regarding diameter and confinement of leads is intended to apply to common arrangements where lead and booster are in contact or separated only by short gaps and thin diaphragms incidental to assembly and packaging within a single unit. If heavy barriers are necessitated by mechanical design or if lead and booster are mounted in separate structural units of a weapon system, larger leads should be used to insure reliability.

69. Boosters

In general, boosters are so large compared with the leads or detonators which initiate them that the initiation may be considered as a local action which is affected by neither dimensions nor confinement.<sup>8</sup> Their dimensions are so much larger than the failure diameters of the explosives with which they are loaded that neither dimensions nor confinement are factors in propagation within a booster. All of the important effects of booster dimensions and confinement are those upon output.

The function of a booster is, of course, to provide adequate output for the reliable initiation of the main charge. The size of booster needed to initiate a main charge, as pointed out in Paragraphs



24 and 25, depends not only upon the explosive material of the main charge, but upon its confinement, its state of aggregation as determined by manufacturing and loading procedures and conditions and the location of the booster with respect to the main charge.

Although the design of a fuze or booster may be made with one particular main charge design in mind, boosters should be made as large and effective as possible to allow for maximum interchangeability and for future changes in main charge design, loading procedures and explosive materials which may require more effective booster action.

If the process of making boosters as large as possible were carried to the extreme, one might ask, "Why not fill the whole round with a booster explosive and forget the booster?" This is essentially the way some small caliber rounds are loaded. The so-called boosters of most 20mm fuzes (see Fig. 51) are closer to leads than to boosters in their size and function. For most high explosive materiel, however, the following motives apply for the reduction in the size of boosters so that the booster will be only a small fraction of main charge size.

(a) Because of the greater sensitivity of booster explosives to friction, impact and bullets, the booster should be protected by as much main charge explosive and metal and offer as small a target as possible.

(b) Hazards such as cook-off and setback tend to increase with the mass of a charge as well as with the sensitivity of the explosive of which they are composed.

(c) The larger the booster, the more it displaces of the main charge explosive, which was chosen for its special output properties.

In general, the mechanical design of a fuze leaves a certain amount of the space in the fuze cavity vacant. If the designer fills this with as large a cylindrical pellet as practical, allowing for packaging the pellet and stand-off, he will be doing as well as possible. In this case, booster geometry is usually not critical.

While it might be possible to derive some notions from the data in Paragraph 19 regarding an ideal length-diameter ratio, if such a ratio is attained by reducing the quantity of explosive in the booster, the improved ratio will result in a less effective booster.

The only reservation which might be expressed about filling the available space derives from the fact that metal fragments accelerated by the action

of the booster may be more effective in the initiation of a subsequent charge than the direct action of the explosive. However, quantitative data on this effect has not been evolved.

## 70. Charge Density Effects

The sensitivities of most explosives reach maxima at a specific density range. The optimum density varies with the explosive material as well as with the mode of initiation. For most situations encountered in military materiel, the optimum density is well below the range of densities at which military explosives are generally loaded. For most practical purposes, the sensitivity of explosives to initiation may be considered to decrease with increasing density. Output, of course, increases with increasing density, the rate of the increase ranging from linear to cubic depending upon the aspect of the output under consideration.

Booster and lead explosives for most military materiel are loaded at densities between 85 percent and 95 percent of voidless (corresponding with loading pressures between 5,000 and 20,000 psi). Within this range, the designer may adjust densities to attain needed compromises between sensitivity and output. If there is the need to employ explosives loaded at densities appreciably outside this range, loading, handling and quality control problems discussed in Paragraphs 96 and 104 should be considered.

In addition to the problems which are clearly in the province of production or quality control, the use of extremes of loading density introduces a group of propagation problems which must be taken into account. The longer reaction zones and more gradual growth and decay of detonation in lower density explosives result in a relatively large variation in detonation velocity, both stable and low order. These variations not only increase the probability of failure due to low order effects at corners, small sections, or abrupt changes, but often make it difficult to pinpoint the exact causes of such failures. In general, very low loading densities should be used only with larger than average charge dimensions.

The decrease in sensitivity with increasing density becomes more abrupt as the voidless density of an explosive is approached. Thus, small variations in density cause increasingly larger variations of sensitivity at very high densities. Before specifying densities in excess of 95 percent of voidless, a careful investigation should be made of factors

in fabrication and loading which can affect loading density to determine the maximum density which can be anticipated in production. It should be determined that the preceding element is adequate for the initiation of lead or booster at this maximum density.

### 71. Output Wave Profile

The output wave profile of the usual cylindrical booster or lead is a relatively simple curve, convex in the direction of propagation. For short boosters initiated by relatively small diameter leads or boosters, the front is essentially spherical, centered at the input lead. For longer charges, the curvature is determined by radial flow and shock propagation as described in Paragraph 18. When the purpose of the lead or booster is only that of reliability initiating a subsequent charge, the gain in effectiveness which might result from a modification of this profile will usually be more than offset by the displacement of high performance explosive with lower performance explosive and inert materials used in such modification. However, main charges for many applications depend for their effectiveness upon the profiles of the wave fronts, which in turn are determined, at least in part, by the boosters which initiate them.

The techniques for the design of charges for the control of wave front profiles are described in Paragraph 30. Charges of this kind are often called explosive lenses because of the close analogy between these techniques and those of geometrical optics.

Most of the means used to shape wave profiles are present in all boosters. However, in most shaping applications in military materiel, the wave shaping features are included in the design of the main charge rather than the booster. In such cases, the important requirement, so far as the booster is concerned, is that it initiates a wave with reproducible and symmetrical profile in the main charge. Variable or assymetrical initiation will, of course, defeat the best efforts at wave shaping.<sup>9</sup>

Two alternate means are available to the designer for the reduction of variability and distortion of the wave front induced in the main charge: (a) specification of precise controls of all variables, or (b) design of a system to minimize their effects by the closest possible approach to the situation in which lead, booster and main charge form a continuum of explosive through which the

wave propagates as a continuous detonation. Of these, the latter is usually the easiest and most satisfactory. The following practices will help in this respect

(a) Use of the most effective lead which is feasible.

(b) Use of a booster diameter that is large compared with the failure diameter of the main charge explosive.

(c) Use of the most sensitive explosives compatible with safety.

(d) Minimization of barrier thicknesses and densities, and of gaps between leads and boosters, and between boosters and main charges. A bare booster in an unlined cavity is nearly ideal.

(e) Use of explosives with the finest particle sizes available and compatible with reasonable loading procedures.

(f) Use of explosives in a density range high enough for relatively rapid growth of detonation and low enough to avoid desensitization (90 to 95 percent of maximum theoretical density is a good range).

The shaped charge effect, as used in a HEAT round (see Paragraph 33) results in the concentration of a substantial fraction of the axial output of an explosive charge in a rather small diameter jet. In most situations found in explosive systems, little advantage accrues from the use of shaped charge leads or boosters.

The most frequent use of shaped charges in explosive trains, except in the projectile charge, is in spit-back fuze systems (Fig. 50). In a spit-back system, the target is sensed by a nose fuze which initiates a booster at the rear of the explosive charge. Initiation of the main charge from the rear is essential for satisfactory performance of the shaped main charge. Note that the shaped auxiliary booster has a hemispherical rather than a conical liner, so as to have less degradation on spin and to provide a wider area of impact on target. Since reliable initiation of the booster in a spit-back system requires direct hits of the relatively small part of the booster exposed at the bottom of the spit-back tube, and since the slug or jet will be deflected by asymmetry of the liner or of the detonation front which projects it, close control is necessary of all dimensions of the auxiliary booster, of the fuze body which confines it, and in the loading procedure. In recent years, with the development of piezoelectric fuze systems, the interest in spit-back systems has waned.<sup>10</sup>

## C. CONSTRUCTION AND FABRICATION

### 72. Loading Techniques

The design of leads and boosters, from the point of view of fabrication and construction, is largely determined by the loading procedure to be used. Three procedures are common

- (a) Insertion of preformed pellets into containers,
- (b) Reconsolidation of preformed pellets to conform to containers, and
- (c) Direct pressing of powdered explosive into containers.

Of the three common techniques, the first is the simplest and most economical. Automatic machines are available which will produce pellets of any size suitable for use in leads or boosters. Most pellets are pressed at pressures between 5000 and 20,000 psi or to corresponding densities. It is the usual practice to limit pellet lengths to about one diameter because large density differences from one end to another are probable in longer pellets. Of course, when this technique is used, provision must be made for the retention of the pellets in their cavities. Clearances resulting from the accumulated tolerances of the cups and containers, requiring the use of inert padding, such as cardboard and felt disks to fill these clearances, may reduce the effectiveness of items loaded in this manner.

The third method, that of loading the powder directly, has the advantage that it can be used to fill a cavity to an exactly predetermined point, with a specified loading pressure (if the last increment is adjusted to compensate for tolerances of the container). This procedure may be expected to result in the most effective as well as the most reproducible performance. It is also the most expensive procedure. When inert components are designed for this type of loading, it is well for the designer to at least lay out a concept of a loading tool. In dimensioning the item, it should be remembered that the consolidating punches should fit the die with only a few thousandths of an inch clearance. Misalignment can initiate the explosive on the one hand or result in excessive binding on the other hand. Columns much over one diameter long are usually loaded in increments one diameter long or less.

The second method, although somewhat simpler and easier to tool for than the third and dispensing with some of the disadvantages of the

first, can give trouble unless a means is provided of dealing with tolerances. If a pellet is reconsolidated at a fixed pressure, all of the tolerances in container, in weight or dimensions of the pellet, as well as any variations in compressibility of the explosive will combine to vary the length of the reconsolidated pellet. Similarly, if the pellet is pressed to a specified length, all of these tolerances and variations will be reflected in the density of the reconsolidated pellet, and consequently in the pressure it exerts on the walls of the container.

### 73. Short leads

Short leads are loaded by any of the techniques discussed in Paragraph 72. When pellets are direct loaded, they may be retained by means of staked-in closure disks as shown in Figure 53, by features incidental to the fuze design as in Figure 54, or by a cup as in Figure 55.

Where there is insufficient space for closure disks or cups, leads are loaded either by pressing powdered explosive or reconsolidating pellets directly into the cavity. An optional method which has proven useful in filling small lead holes nearly flush without adjusting weights for each individual

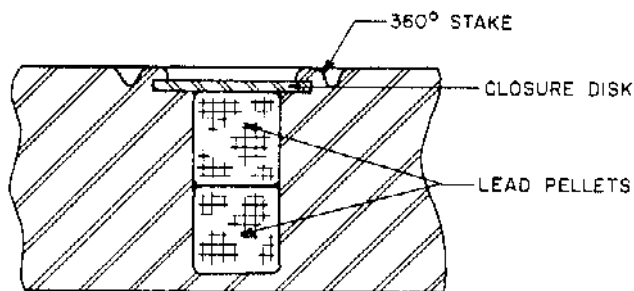

Figure 53. Lead Pellets Held in Place by Staked-in Closure Disk

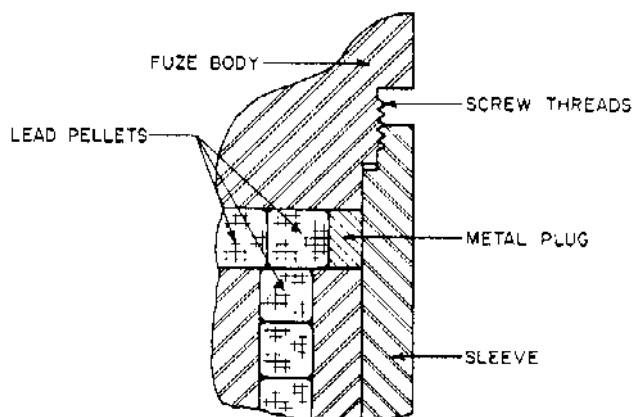

Figure 54. Lead Retained by a Feature of Fuze Design

item is that of loading somewhat more than enough to fill, and breaking off the excess as in Figure 56. Where, as in Figure 57<sup>a</sup>, the open end of a lead is at a sliding surface, it is the usual practice to coat the ends with lacquer or varnish to prevent dusting. Onion skin disks are also used. Allowance should be made for the sealant in loading. This method involves the risk of gumming the surface so as to impede arming. The holes in which leads are to be loaded directly are sometimes scored to improve explosive retention.

Most leads are loaded into cups. Both flanged and straight cups of standardized dimensions are used. Where leads completely packaged in metal are desired, closure disks are crimped in place. Moisture resistance is sometimes augmented by painting the crimped end with a lacquer, but the seals so obtained are not reliable.

Leads may be installed by crimping in place (Fig. 58), securing with adhesive, force fitting, or by pressing the explosive into the cup after the cup has been inserted into the hole. The first method is the best adapted to economical production but should be specified only if the designer has taken into account the effects of clearances upon confinement as discussed in Paragraph 72.

In designing for a force fit, the controlling dimension is the maximum cup dimension after loading. The diameter is slightly larger than the manufactured cup to allow for clearance between cup and loading tool. Since the hoop stress induced by the loading pressure is usually larger than the yield stress of the cup material, the cup expands to fit the tool. The cup may also expand slightly when removed from the loading tool because of residual stresses from loading. Therefore, when the lead cup is to be assembled as a force fit, diametral dimension and tolerance should be specified on the loading drawing of the lead.

#### 74. Long Leads

Four types of construction have been used for explosive transmission between widely separated arming devices and boosters: (a) elongated leads or stacks of lead pellets of the types described in Paragraph 73, (b) spit-back systems, (c) detonating cord, and (d) MDF (see Paragraph 87).

Of the various adaptations of short lead fabrication practices to long leads, the reconsolidation of pellets is preferable. In loading loose pellets in a long hole, there is always a chance that one will jam, leaving a gap which can be detected only by

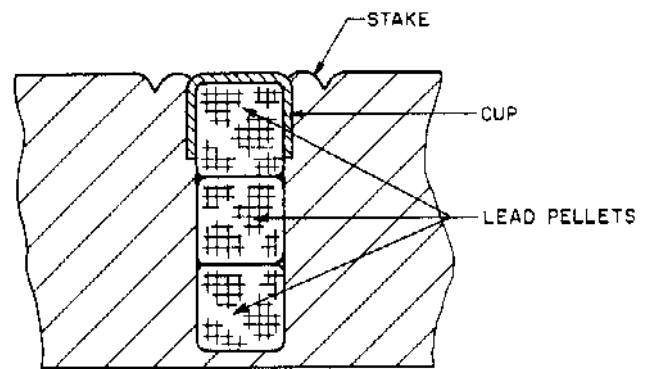

Figure 55. Lead Retained by a Cup

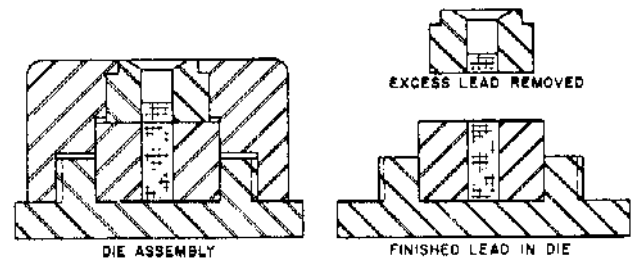

Figure 56. Explosive Loaded by Breaking off Excess

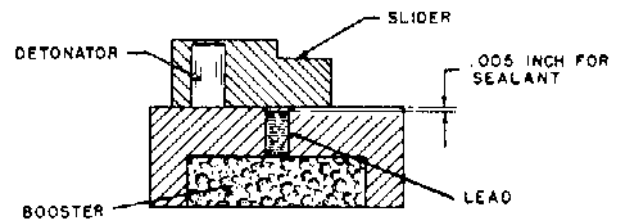

Figure 57. Lead End Coated with Sealant

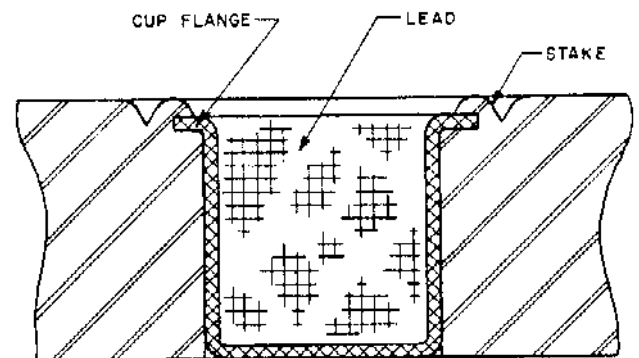

Figure 58. Lead Cup Crimped in Place

X-ray. Use of pellets without reconsolidation may lead to failures because of acceleration forces (setback) producing reconsolidation with resulting gap. The small ram clearances necessary for direct loading of powder, combined with a small deviation

from straightness, can cause enough binding to seriously affect the reliability of the system.

Spit-back systems are discussed in Paragraph 71. Essentially, a spit-back system consists of a small shaped charge, which is initiated by a fuze system and which initiates a remote booster or receiver by the action of its jet. Most spit-back systems have been used to attain rear initiation of shaped charges from nose fuzes.

Detonating cord has the advantage that it can be bent around curves and may thus be used as the basis for flexible leads to transmit detonation along complex paths. As a very convenient form of a preloaded long explosive column, it has also been used, for long straight leads. Detonating cord and mild detonating fuse are described in Paragraph 87.

### 75. Boosters

Radial confinement is much less important in its effect upon booster performance than upon lead performance. For this reason, unreconsolidated pellets are frequently used in booster construction. Cardboard disks and felt pads are sometimes used to take up tolerances, even though they detract from output if used at the bottom of a booster and from input sensitivity, if used at the top. An arrangement where the variations in pellet length may be taken up by screwing a cap to a snug contact with the pellet would be preferable if possible. A method of forming booster pellets to clear the fillets in the bottom of booster cups is illustrated in Fig. 59.

It is important that loading density of boosters be uniform. If density is allowed to vary unduly, this variability will be reflected in the profile of the wave front generated in the main charge. Most explosives vary in density from point to point with a resulting variation in detonation velocity. The small and reproducible gradient occurring between the ends of a pellet is not usually serious. However, with careless charging, it is possible for the explosive to stack obliquely against one side of mold or container as shown in Figure 60. Explosives so stacked will not completely redistribute themselves under pressure so that the resulting pellet may be appreciably denser at one side than at the other causing asymmetry of the output wave.

Housings for boosters take many forms. They may be cavities machined into fuze bodies or they may be separate packages. Some booster charges have no housings at all and some are housed in thin drawn metal cups or thin walled tubing with closure disks crimped in place. By far the most common housings are of the type shown in Figure 49 which

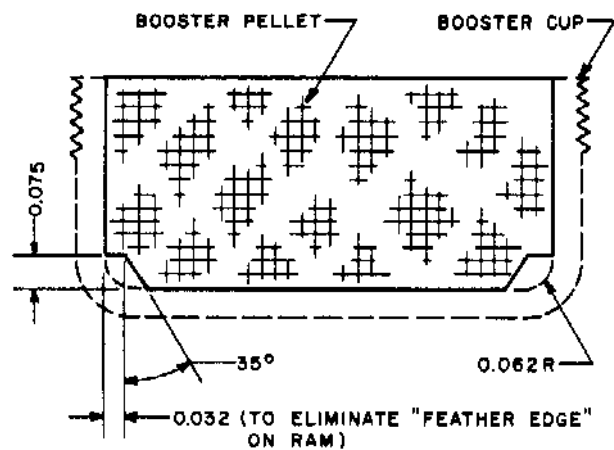

Figure 59. Chamfered Booster Pellet

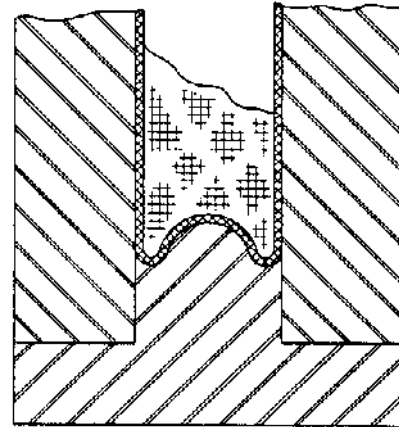

Figure 60. Improper Charging of Cup

are simple cups, drawn, extruded, cast or machined with walls thick enough to be threaded so as to screw into the fuze body. For the usual thread pitch, NS-16, the walls must be something over a sixteenth of an inch thick. Unless metal fragments are needed to defeat a heavy barrier, the walls through which the detonation is to be communicated to the main charge should be as light as consistent with mechanical strength.

Most boosters are closed merely by screwing the booster cup or cap into or onto the fuze. Others are closed by crimping a disk in place, cementing or even soldering the cover on with low melting solder. Where covers or cups are screwed against surfaces close to a pellet, it is the usual practice to use a paper gasket to prevent explosive dust from being pinched directly between metal surfaces. Where high spin accelerations are anticipated, it is a frequent practice to stake the threads heavily after the booster has been screwed closed. Threads and crimps are usually sealed. Another precaution is the use of left-handed threads.

## REFERENCES

### CHAPTER 7

*a-i Lettered references are listed in Paragraph 12 (end of Chapter 1).*

1. TM 9-1300-203, *Ammunition for Antiaircraft, Tank, Anti-tank, and Field Artillery Weapons*, Department of the Army, August 1960.
2. T. Fruchtman, *Development of 2.75-Inch HEAT Rocket Head T20E1 (M1) (U)*, Picatinny Arsenal Technical Report 2252, December 1955 (Confidential).
3. A. J. Pascazio, *The Suitability of a Bare PBX Booster Pellet in the 2.75-Inch Head M1 Rocket Head*, Picatinny Arsenal Technical Report 2271, November 1955.
4. *The Rate of Detonation of Various Explosive Compounds and Mixtures*, (from Explosives Research Laboratory) Office of Scientific Research and Development, OSRD Report 5611, 15 January 1946.
5. L. D. Hampton, *Minimum Diameter for the Propagation of Detonation in Tetryl, RDX, and PETN (U)*, Naval Ordnance Laboratory (White Oak), NAVORD Report 4082, 1 August 1955 (Confidential).
6. L. D. Hampton and R. H. Stresau, *Small Scale Technique for Measurement of Detonation Velocities*, Naval Ordnance Laboratory (White Oak), NAVORD Report 2282, 27 December 1951.
7. *Proceedings of the Electric Initiator Symposium (U)*, held at the Franklin Institute 11-12 September 1957, paper XXXIII (AD-153 579) (Confidential).
8. J. Savitt, *The Propagation of Detonation in Some Special Explosive Systems (U)*, Naval Ordnance Laboratory (White Oak), NAVORD Report 2844, 13 April 1953 (Confidential).
9. *Proceedings of Detonation Wave Shaping Conference (U)*, Picatinny Arsenal, held at Jet Propulsion Laboratories, California Institute of Technology, Pasadena, California, 5-7 June 1956. Paper by G. M. Bryan et al., "Effects of Asymmetry on Shaped Detonation Waves" (Confidential).
10. T. Fruchtman, *Development of the T2017E1 2.75-Inch HEAT Rocket Head (U)*, Picatinny Arsenal Technical Report 2257, December 1955 (Confidential).

## MAIN BURSTING CHARGES

## A. DESCRIPTION

## 76. Function

The purpose of the explosive train is achieved by initiating effective detonation on the main bursting charge of high explosive ammunition. The resulting detonation is the source of energy for the output effect of the item, designed to reduce or preferably destroy military targets.

For other types of military materiel, such as chemical ammunition, the main bursting charge (called *burster*) is designed to open the case and disseminate the contents of the round.

Each ammunition item is color-coded to indicate the type of loading according to MIL-STD-709.<sup>1</sup>

## 77. Typical Main Bursting Charges

*a. High Explosive (HE) Ammunition.* Typical blast or fragmentation ammunition is primarily a container filled with explosive. Its size, shape and construction are determined by ballistic and structural considerations which vary depending on the vehicle.

A typical high explosive projectile is shown in Figure 61.<sup>2</sup> To withstand setback and spin forces, such rounds usually have wall thicknesses and metal to charge ratios greater than optimum for blast or fragmentation characteristics (see Paragraphs 31 and 32). Fuze seat liners are desirable to prevent the occurrence of loose explosive in the fuze well (which could constitute a hazard during the fuzing operation).

The armor-piercing projectile shown in Fig. 62<sup>2</sup> is presented for historical interest. Now, projectiles of this type contain no explosive filler.

Because the forces to which mortar projectiles are subjected are much lower, they may be designed for more nearly optimum charge to weight ratio in accordance with principles outlined in Paragraphs 19 and 30. The same holds true for rocket and

missile warheads and, for that matter, grenades, which are subject to relatively mild forces.

High capacity, high explosive bombs (Fig. 63<sup>3</sup>) are thin walled tanks, the thickness of which is no more than sufficient to withstand normal rough handling. As much as 70% of the total weight of such a bomb may be that of the main bursting charge. For fragmentation and target penetration, heavier cases are sometimes used. Land mines are merely packaged explosive charges with fuzing systems (Fig. 64<sup>3</sup>).

Underwater mines, depth charges, and torpedo warheads are generally relatively thin-walled containers with shapes dictated by structural and pre-explosion functional considerations. These items are usually loaded with aluminized explosives to produce high intensity shock waves.

*b. High Explosive Antitank (HEAT) and High Explosive Plastic (HEP) Ammunition.* As is pointed out in Paragraph 33, the shaped charge effect of HEAT rounds results from the progressive collapse of the liner as it is engulfed, from the rear, by the detonation wave (Fig. 65<sup>2</sup>). Thus, in addition to requiring a special configuration, a shaped charge must be initiated from the rear in order to form an axially symmetrical detonation wave. Initiation can be from a piezoelectric nose element to a base fuze or by means of a spit-back system as shown in Figure 50. Homogeneity of the explosive charge is particularly important in HEAT rounds.

The HEP round is one which deforms, to attain intimate contact with a large area of the armor which is attacked, before detonating. The detonation is transmitted to the armor as a shock wave which, upon being reflected, causes the inner surface to spall. Both case and filling of such rounds must deform.

*c. Chemical Ammunition.* The main bursting charges of chemical ammunition are no larger than necessary to burst the case and disseminate the

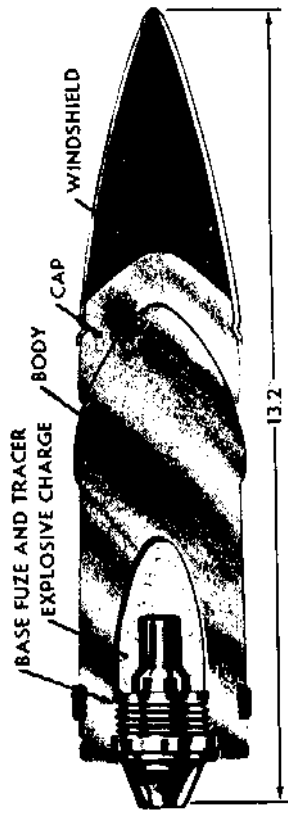

Figure 62. Armor Piercing Projectile

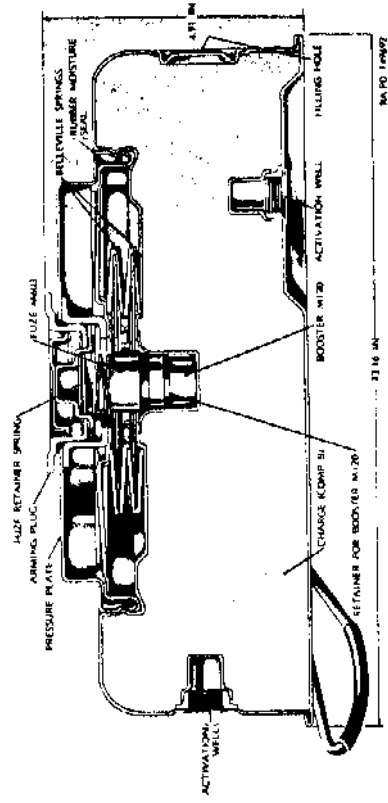

Figure 63. General Purpose Bomb



Figure 64. Antitank Mine (M15)

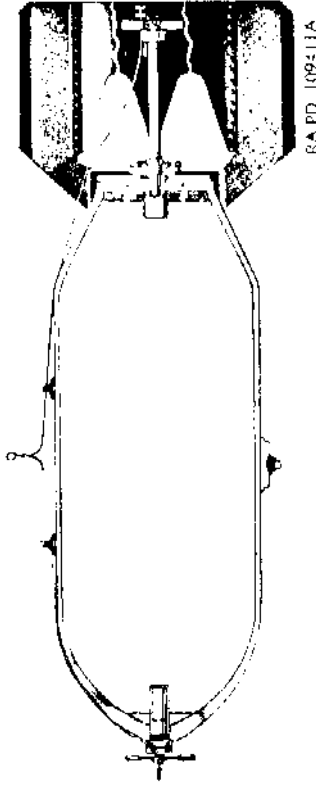

Figure 65. High Explosive Antitank Projectile



Figure 66. Burster Type Chemical Projectile



contents.<sup>4</sup> They are usually small diameter cylindrical charges which often extend the full length of the projectile (see Fig. 66<sup>2</sup>).

### 78. Size and Weight

The total weight and bulk of weapon plus ammunition is limited by the capacity of the means of transportation. In modern warfare, the variety of such means and combinations which might be used is so great that such factors can be considered only in terms of overall operations analysis. The explosive charge designer will usually be given an upper limit of dimensions and weight of a round. Under such circumstances, it is usually best to utilize as much of this weight and space as possible in the main charge. Where a definite tactical purpose is specified, the designer may make a worthwhile contribution if he can show how to accomplish this purpose with a significantly smaller or lighter round. This weight-saving may be used to increase the tactical effectiveness of the system by providing a larger complement of ammunition or by increasing its mobility. In these terms, the smallest and lightest round which will serve the specified purpose is the best design.

Size and weight is often limited by ballistic factors. In gun-launched projectiles, the outside diameter (caliber) is fixed. The length of the round is limited in spin-stabilized weapons by considerations of stability. Setback forces and still higher impact forces place such stringent demands on the structural properties of many rounds that only a small fraction of the total weight and space remain for the main charge.

In chemical, flechette, leaflet, signal and bacteriological ammunition, where the function of the bursting charge is that of releasing and sometimes disseminating non-explosive items, the bursting charge should be as small as is compatible with the performance of this function. Not only does a larger charge displace some of the principal cargo, it also increases the probability or magnitude of damage to the cargo. The size and composition of bursting charges for such items are determined by the interaction of considerations of case strength, desired area of dispersion, vulnerability of cargo to damage, etc. These considerations are clearly so specifically applicable to particular devices that formulas of general applicability are not feasible.

Let us consider for example, a marker projectile. It is intended to produce a conspicuous colored cloud, visible for a few minutes, to serve

as a signal or marker for ground targets. Red, green and yellow markers are standard. Standard projectiles are used with a smoke-producing material. They are loaded by drilling a cavity in the pressed charge and inserting an axial bursting charge.

The smoke material consists of a fine powder, usually dye diluted with a nonreactive agent, such as sodium chloride pulverized to an average 10-micron particle, treated with an appropriate diluent. Typical smoke mixtures used in the 90mm M71 projectile are

(Red) 80/20 1-methylamino-anthroquinone/sodium chloride

(Yellow) 50/50 dimethylamino-azobenzene/sodium chloride

(Green) 40/40/20 auramine hydrochloride/1,4-dimethylamino-anthraquinone/sodium chloride.<sup>5</sup>

The bursting charge for this projectile is a cast cylinder of 67/33 baratol. A coating of acid-proof black paint is used on the inner surface of the smoke charge to prevent chemical interaction between it and the baratol bursting charge.

## B. INITIATION

### 79. Sensitivity

An essential factor in the choice of an explosive for use in main bursting charges of military items is its insensitivity to stimuli incidental to handling, storage, and launching which are discussed in Paragraphs 39-42. Such insensitivity is, in general, inseparable from that to purposely applied stimuli. Hence, boosters are usually necessary for the reliable initiation of main bursting charges.

The initiation of a main charge explosive is not always a matter of simple fire-misfire reliability. All main charge explosives (including TNT) are capable of low order detonation under conditions where the probability of complete failure is low. Thus, the problem of main charge initiation is that of reliably initiating high order detonation. Experimental investigations of this aspect should include output determinations, such as a fragmentation test.<sup>6</sup>

The design of boosters for the reliable initiation of main charges is discussed in Paragraph 71. The relative booster sensitivity of various explosives is given in Table 20. Other comparisons appear in Tables 12 and 13. When a less sensitive explosive is to be substituted in a main charge, the adequacy of the booster must be verified.

## 80. Explosive Loading

Voids, imperfections and discontinuities in an explosive charge play an important role in the transmission and propagation of detonation. For example, cast charges, in which the voids tend to be fewer, larger, and farther apart, are appreciably less sensitive to initiation than pressed charges of the same composition and density (Table 12). Casting procedures, such as "cream casting" which are conducive to the formation of fine, uniform crystal structure will sometimes increase booster sensitivity while improving charge quality at the same time. Other loading techniques are discussed in Paragraphs 93-96.

In general, particle size and particle size distributions which are conducive to the best loading characteristics are also conducive to initiation difficulty. The tendency is for sensitivity to increase with uniformity of particle size and with decreasing particle size. Explosives tend to become less sensitive with increasing density, within the range used in military items. In taking advantage of modern techniques to approach maximum theoretically attainable densities, the designer may lose more in reliability than he gains in performance or safety.

## 81. Booster Position

Since detonation is transmitted between charges through their adjacent surfaces, the reliability and effectiveness of transmission is directly related to the area of the surfaces (see Paragraph 25). Hence a booster which intrudes into a cavity in the main charge, is more effective, other conditions being equal, than one which can communicate only through its end.

Intuitive reasoning leads to the expectation that gaps and barriers will be detrimental to the transmission of detonation. However, as pointed out in Paragraph 27, they have been observed under some circumstances to be useful means of increasing reliability and effectiveness. It may be suspected that the booster cups (provided primarily as containers) combine with the clearances provided for ease of assembly to make many service items as effective as they are, although relatively few designs have been consciously optimized from this point of view. Where improvements in manufacturing techniques or design changes make it possible to reduce clearances between boosters and fuze wells,

such reductions should be made only after determining that they will not adversely affect reliability. Similarly, changes in booster cup and fuze seat liner materials should be considered in this respect.

## 82. Auxiliary Boosters and Boosted Surrounds

When fuzes of several intrusion lengths are to be used in a main charge, the fuze well must, of course, be deep enough to receive the longest fuze. In such cases, auxiliary boosters, usually pellets contained in thin drawn sheet metal containers, are used to fill the space left when shorter fuzes are used. Where the boosters of existing fuzes are inadequate, auxiliary boosters may be used, or a relatively small fraction of the main charge, immediately surrounding the booster, may be loaded with a more sensitive explosive than the rest of the charge. These supplementary charges are sometimes referred to as boosted surrounds. TNT surrounds have been used with amatol main charges in 105mm howitzer projectiles,<sup>2</sup> and Composition A-4 boosted surrounds are used in 40mm projectiles loaded with MOX type explosives.<sup>7</sup> In these examples, the insensitive main charge explosives are employed for reasons other than safety (which would be adequate for the items named if they had been loaded entirely with the explosive used in the boosted surround). Relative advantages of various designs, from this point of view, must be considered in terms of desired terminal effects.<sup>4</sup>

## 83. Confinement

Confinement has a great effect on the sensitivity of an explosive charge (see Paragraph 27). Because of the relatively high cost of statistical experiments with loaded full-scale ammunition, data are scarce. However, there is every reason to expect that the trends indicated in initiators also apply to larger charges. It is reasonable to expect that the same explosive similarly loaded will be more sensitive in projectiles than in bombs, and in armor-piercing projectiles than high capacity projectiles. For items as heavily confined as projectiles, smaller projectiles are probably more easily initiated than larger ones, if the booster diameter remains constant. On the other hand, for non-metallic mines, which are rather poorly confined, the self-confinement provided by the surrounding explosive probably makes larger items more sensitive.

## REFERENCES

### CHAPTER 8

*a-i Lettered references are listed in Paragraph 12 (end of Chapter 1).*

1. MIL-STD 709, *Ammunition Color Coding*, June 1960.
2. TM 9-1901, *Artillery Ammunition*, Department of the Army, September 1950.
3. TM 9-1900, *Ammunition General*, Department of the Army, June 1956.
4. Engineering Design Handbook 245(C), *Ammunition Series, Design for Terminal Effects (U)* (Confidential).\*
5. S. D. Stein and Paul B. Tweed, *Development of Shallow Cavity Red Marker Shell for 90 MM Guns*, Picatinny Arsenal Technical Report 2294, August 1956.
6. M. E. Pollack and D. E. Seeger, *Study of Initiation of High Explosives by Booster Pellets (U)*, Picatinny Arsenal Technical Report 1956, 17 September 1953 (Confidential).
7. S. M. Adelman, P. B. Tweed and J. D. Hopper, *Study of Loading of MOX-2B into 20 MM Shell and Acceptance Tests of Cartridge Containing Projectile Filled With This Explosive (U)*, Picatinny Arsenal Technical Report 1935, 11 May 1953 (Confidential).

---

\* See inside back cover for handbook designation.

## OTHER EXPLOSIVE CHARGES

## A. ACTUATORS

## 84. Description

Actuators are explosive devices that produce gas at high pressure in short periods of time into a confined volume for the purpose of doing work. They are small, reliable, one-shot devices well suited to remote control of small movements such as switch closures. Most actuators are electrically initiated. Hence, their initiation mechanism and their input characteristics are those of electric initiators described in Paragraph 52.

A dimple motor is similar in construction to an electric detonator except that the bottom is outwardly concave and the explosive is a small gas producing charge (Fig. 67). The pressure of the gas liberated by the reaction inverts the end to a convex surface. A typical dimple motor imparts a 0.10-inch movement against an eight-pound load. The relatively complex curvature of the dimple, as well as accurate control of metal condition, is necessary for reliable and satisfactory functioning.<sup>1</sup>

The lower cups of bellows motors are metallic bellows.<sup>2</sup> A typical bellows motor (Fig. 68) moves one inch against a ten-pound load. In addition to linear movement, bellows motors may be used to give a rotary movement. They have been made to work against loads as large as 100 pounds.

In a piston motor, the gases generated by the explosive push a piston in the cup which acts as a cylinder. The one shown in Figure 69 moves  $\frac{5}{16}$  inch against a 20-pound load.

Each of these motors has been used to open or close switch contacts or to provide other mechanical movement. A number of commercial units have been designed containing a motor and a series of switch contacts within a single unit. The one shown in Figure 70 has four double-pole, single-throw switches in which each position is available either normally open or normally closed.

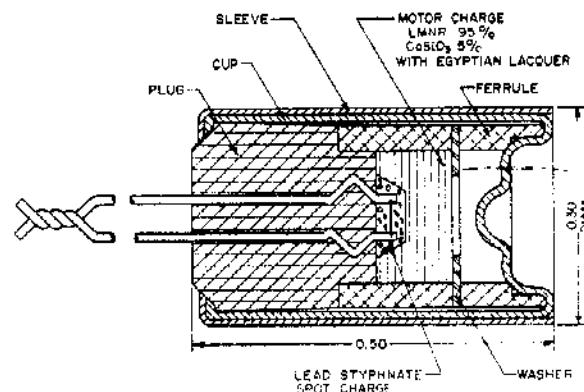

Figure 67. Dimple Motor (T3E1)

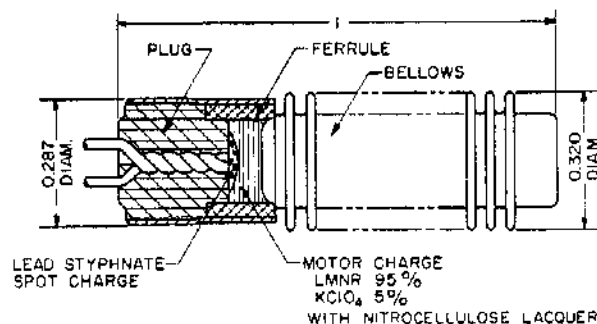

Figure 68. Bellows Motor (T5E1)

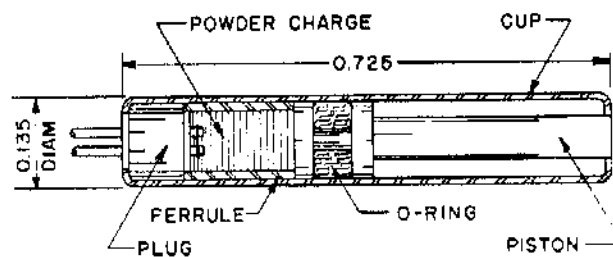

Figure 69. Piston Motor

Courtesy  
ATLAS CHEMICAL  
INDUSTRIES, INC.

An interesting variation in a switch is the pyroswitch which has no moving parts, and hence, is not strictly an actuator. The pyroswitch (Fig. 71) is based on the fact that certain mixtures of gasless powders are non-conductors of electricity before burning but good conductors after burning.

Non-electric actuators are based on pull-type igniters. They have been developed to perform delayed mechanical functions, as in parachutes.

### 85. Output Characteristics

The usable output from the explosive charge of an actuator is the work accomplished by the expansion of the gases liberated as it burns. The magnitude of this output has been computed for propellant actuated devices based on assumptions of adiabatic conditions and no motion before powder burn-out.<sup>3</sup> It is not likely that these equations can be applied to actuators.

For most design purposes, simple scaling of charge size to requirements from existing items will suffice. In such scaling, the quantity of charge should be proportional to the pressure or force desired for constant volume, to the volume for a constant pressure, or to the energy requirement. In dimple motors, the quantity of explosive used is so small that it presents measuring difficulties in production. One means of alleviating these difficulties is that of using a mixture containing a small percentage of a gas producing material (3 percent nitrostarch) with an essentially gasless mixture (lead selenium). Recent developments in the design and production of initiating elements have made it possible to use lead styphnate for dimple motor charges. Lead mononitroresorcinate, which produces only about one-third as much gas as lead styphnate, has been used for bellows motors.

In dimple and bellows motors, which have appreciable internal free volumes before movement, the rapid burning of materials like lead styphnate and lead mononitroresorcinate is tolerable. In the usual piston motor, however, the rapid burning of these materials within the small free volumes would cause the pressure to rise above the bursting point. Smokeless powder of the sporting arm type has been effective.<sup>4</sup> Detonation, of course, would be disastrous in any actuators, so azides and other detonation-prone materials are avoided.

Often squibs can be used as actuators. Actuators can also incorporate one of the various delays discussed in Paragraph 58.

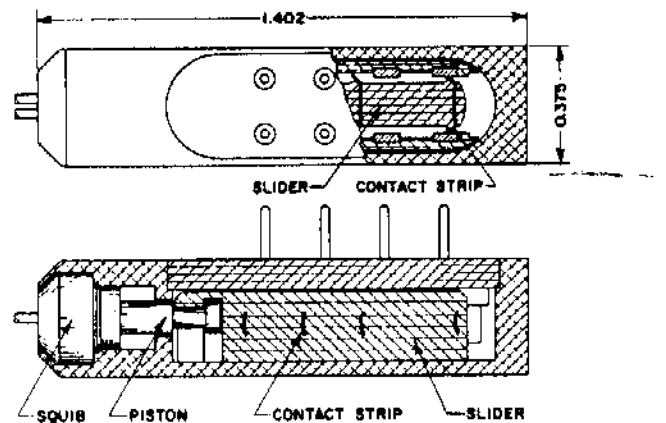

Figure 70. Multiple Contact Switch

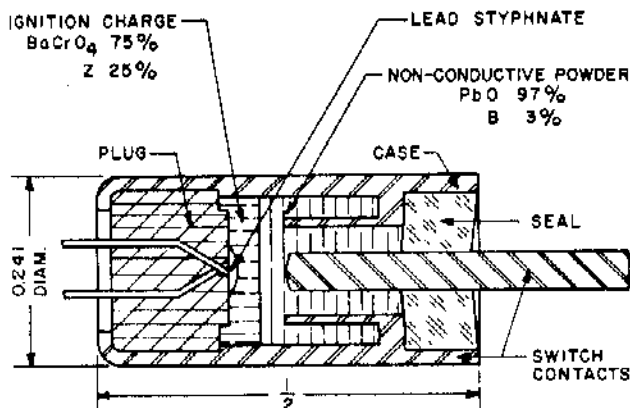

Figure 71. Pyroswitch

## B. DEMOLITION DEVICES AND ACCESSORIES

### 86. Destructors

The destruction of equipment, either to prevent it from falling into enemy hands or to halt further functioning of a missile which has gone out of control, is accomplished by explosive devices called destructors. Destructors are also used as complete initiating systems for improvised mines, demolition devices and the like. A wide variety of explosive destructors has been devised to accomplish such destruction. Destructors vary in size and shape depending upon their specific applications.

A typical destructor, the Universal Destructor M10, is shown in Figure 72<sup>5</sup>. The principal portion is the pair of booster cups. The one nearer the activator bushing contains tetryl pellets with a center hole for the insertion of the activator while the other one contains solid tetryl pellets. A bushing with two different external threads permits the device to fit most fuze cavities. The input end of

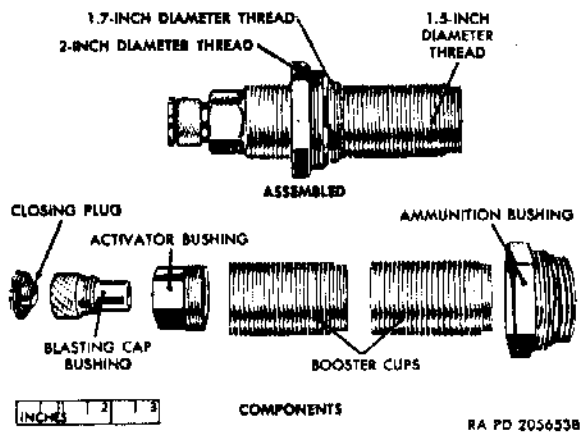

Figure 72. Universal Destructor (M10)

the destructor can accommodate a firing device and blasting cap combination, a firing device and activator combination or a blasting cap, electric or nonelectric.

Construction of such a manual destructor as the M10 differs greatly from that of destructors which are built into missiles or classified components. The large explosive charges required for these purposes must be as safe to handle as those of the main charges. Further, accidental functioning of such charges must be precluded as definitely as that of the main charges. For these reasons, large destructors are essentially special fuzing systems which have their own explosive trains and safety devices. Hence, destructors which form a part of a weapon system are designed in the same manner as the functioning components of the system. The destructor is usually tucked away into whatever free space is available.

### 87. Explosive Tubes and Sheets

*a. Detonating Cord.* Detonating cord consists of a textile or plastic sheath loaded with explosive. The explosive strength of detonating cord is given in the number of grains of explosive per foot. Primacord is made in a number of loadings: PETN in 30, 40, 50, 60, 100, 150, 175, 200, and 400 grains per foot, and RDX in 70 and 100 grains per foot. Propagation rate of standard Primacord is quoted as 6300-6400 m/s for either explosive. Somewhat higher velocities are attainable. Coatings (over the textile) include asphalt, wax, polyethylene, vinyl, Hycar rubber and polyvinyl chloride.

*b. Mild Detonating Fuse (MDF).* This material consists of a column of explosive in a lead sheath. MDF loaded with PETN is made in loadings of 1, 2, 5, 10, and 20 grains per foot in several diameters.

It has been established that the detonation velocity of MDF may be raised to over 8100 m/sec by subjecting it to hydrostatic pressure of 55,000 psi.<sup>6</sup> This material has attracted wide interest for military applications. Several special variants have been made, including special sizes, other explosives and metal coverings. A completely contained type has been produced with textile and plastic covering, thick enough to be unbroken at the surface after detonation of the core.

Where MDF is to be used to transmit detonation between a detonator and a charge of booster explosive, the limitations of transmission of detonation between small and large columns of explosive, discussed in Paragraphs 25 and 71, must be considered. A series of mild end primers is available for use with MDF.

Pyrocure\* is similar to MDF, loaded with a detonating-ignition composition containing hot particle-producing components as well as organic high explosives. Compositions are varied to meet various propellant and pyrotechnic ignition requirements.

*c. Flexible Linear Shaped Charge.* A flexible linear-shaped charge which is essentially MDF drawn into a V shape, FLSC is available in a variety of sizes and casing materials. It has been used successfully in metal cutting applications.

*d. Sheet Explosive.* Flexible sheet explosive is a mixture of PETN with some additives. This material has the consistency of a vinyl floor covering and can be cut with a sharp knife or razor blade. Sheets are 10 by 20 inches and of various thicknesses. Extrusion in other shapes are also available. Blasting caps are recommended for initiation.

### 88. Demolition Blocks

Composition C-4 and its variants are moldable mixtures of RDX with various other solids which forms a putty-like moldable plastic explosive. Properties of these materials are given in Tables 12 and 20. They are available in bulk form and in the form of demolition blocks.<sup>7</sup> With reasonable care, the material from the demolition blocks may be remolded into almost any desired shape without appreciable reduction of density from the 1.50 gm/cc of the blocks. For mock-up experiments, Composition C-4 at this density resembles many of

\* Trademark product of E. I. duPont de Nemours and Co., Wilmington, Del.

the standard main charge explosives closely enough in output characteristics (Paragraphs 29-33) that experiments with such mockups can be very useful for the early investigation of design concepts. Where simulation of explosives of higher performance than that of Composition C-4 at a density of 1.5 is desired, it can be consolidated to a density of 1.6 or higher, with relatively low ram pressures, if vacuum techniques are used. Where less brisant materials are desired, military dynamites LVD<sup>8</sup> and MVD<sup>9</sup> may be used.

### 89. Explosive Bolts

Explosive bolts are a convenient means for separating subassemblies which, up to the instant of desired separation, must be firmly attached. Stage separation of multistage missiles is a typical application. In its most rudimentary form, an explosive bolt is merely a bolt loaded with sufficient explosive to shatter it upon functioning. A bolt of this description might serve some purposes, but in many applications, its use would subject nearby components of the system to damage by fragments.

A more suitable type of explosive bolt for most applications remains one which parts at a predetermined surface and is otherwise essentially intact. One method of attaining this end is that of so weakening the bolt at the intended breaking point that it may be broken by an explosion too weak to do other damage. A circumferential groove will achieve this purpose.

By taking advantage of the interactions of reflected tension waves and the rarefactions which follow detonation induced shocks, it is possible to design an explosive bolt of nearly the full strength attainable in the diameter used which will break along a predetermined surface. A shock wave in a condensed medium is reflected from a free surface as a tension wave. The shock produced by a detonation tends to retain the pressure-time profile, and hence the pressure-distance profile of the detonation itself. This profile is sharply peaked, so that the shock is followed closely by a rarefaction. The interactions of these reflected tension waves with one another, and with the rarefaction waves behind the detonation, induce fracture.<sup>10,11</sup> Such interactions are utilized in the explosive bolt illustrated in Figure 73.

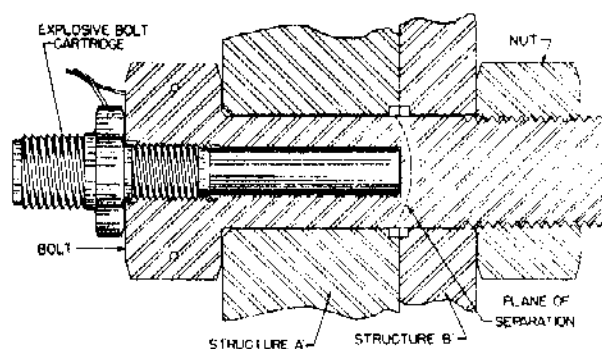

Figure 73. Explosive Bolt in Which Reflected Tension Waves Are Utilized

## REFERENCES

### CHAPTER 9

a-i Lettered references are listed in Paragraph 12 (end of Chapter 1).

1. F. K. Van Arsdel, *Development of an Improved M4 (T3) Explosive Dimple Motor (U)*, Picatinny Arsenal Technical Report 2689, June 1960 (Confidential).
2. F. K. Van Arsdel, *Development of an Improved M6 Explosive Bellows Motor (U)*, Picatinny Arsenal Technical Report 2648, October 1959 (Confidential).
3. Engineering Design Handbook 270, *Propellant Actuated Devices*.\*
4. E. E. Kilmer and M. J. Falbo, *The Development of the XE-16A Actuator, Explosive, as a Replacement for the MK1, MOD 0 Actuator, Explosive*, Naval Ordnance Laboratory (White Oak), NAVORD Report 6111, 26 May 1958.
5. TM 9-1940, *Military Explosives*, Department of the Army, April 1955.
6. G. R. Abrahamson and G. B. Huber, "Precision High-Velocity Detonating Cord," *Review of Scientific Instruments*, 30, 10, 934-936 (1959).
7. T. W. Stevens, D. E. Seeger and D. H. Stone, *Development of the M5 and M5A1 Demolition Blocks*, Picatinny Arsenal Technical Report 2332, August 1956.
8. B. J. Zlotucha, *Preparation of Low-Velocity Military Dynamite on a Semiplant Scale (U)*, Picatinny Arsenal Technical Report 2576, November 1958 (Confidential).
9. C. E. Jacobson and B. J. Zlotucha, *Development of a Military Dynamite Equivalent to Commercial Dynamite*, Picatinny Arsenal Technical Report 2239, February 1956.
10. J. Savitt, R. H. Stresau and L. E. Starr, "Compression Wave Velocity Experiments with Copper," *J. Applied Physics*, 10, 1307-1311 (1954).
11. J. S. Rinehart and J. Pearson, *Behavior of Metals Under Impulsive Loads*, American Society of Metals, Cleveland, 1954.

\* See inside back cover for handbook designation.

# LOADING AND FABRICATION

### 90. Process Selection

Most solid high explosives are manufactured by processes which yield granular material. Their bulk densities are generally somewhat less than one gram per cubic centimeter. They are used in military applications as solids of well defined configurations, usually at densities between 1.5 and 1.7.

The two principal loading techniques are casting and pressing. All explosives in common military use can be pressed. However, those which are castable are usually cast because of the greater convenience and flexibility of this process. As a rule of thumb, main bursting charges are cast while small explosive components (initiators to boosters) are pressed.

More pounds of military explosive are cast than are loaded by all other processes. Essentially, the casting of an explosive involves only melting it and pouring it into a charge case or mold. In practice, like most fundamentally simple processes, the procedures necessary to cast charges of the quality needed for acceptable performance and safety can become quite elaborate.

The most common procedure for pressing powdered explosives is that of pouring the powder into a mold and pressing it with a ram which fits snugly. The pressure most frequently specified for charges used in military items is 10,000 psi. Charges may be pressed directly into their containers or pressed into molds and ejected as pellets. Where they are pressed into containers of lengths greater than the diameter, the explosive is usually loaded in increments.

After pressing or casting, it is sometimes necessary to machine explosives, either to provide a smooth surface or a fuze cavity at the filling hole, or to produce complex contours required for some specialized purposes. In some cases, mating contours of two charges are cemented together.

Of increasing importance are the plastic bonded explosives (PBX). These are exactly what

the name implies, and like plastics can be obtained in many different forms. Hence, PBX's are available for molding, casting or machining. They vary from rigid to rubbery consistencies. High mechanical strength and high thermal stability are possible.<sup>1</sup>

Other considerations for process selection include fabrication facilities and suitability of the explosive for its intended application.

### A. CASTING

#### 91. Projectile Preparation

As part of the manufacturing process, the interior wall of the projectile is sprayed with paint or varnish, primarily to prevent rusting of the projectile in storage. The requirements of the coating are that it be compatible with the explosive, adhere well to the projectile wall and offer a good bonding surface for the explosive. The latter requirement is necessary to prevent rotation of the charge relative to the spinning projectile. The finished coating at the base of the projectile should be thin enough to assure thorough drying and be sufficiently smooth to eliminate irregularities that could otherwise form air pockets.

The molten explosive is usually poured through a funnel-former. This tool is specially designed to furnish the desired surface contour upon removal and to hold a sufficient reservoir of molten explosive to replenish the shrinking, cooling mass beneath it. A thin film of silicone grease is applied to the former to aid in its release when the explosive has solidified.

#### 92. Effect of Casting Procedure on Charge Characteristics

*a. Porosity and Cavitation.* The porosity of an explosive charge is usually introduced by two principal causes, entrained air bubbles and dis-



solved gases, and shrinkage which occurs as the charge solidifies and cools. The higher the temperature of casting and the more fluid the melt, the larger is the fraction of the entrained air which forms into bubbles and floats out of the charge. On the other hand, these conditions maximize cavitation due to shrinkage. The most serious effect of shrinkage is that known to metal founders as "piping." The casting solidifies from the outside and consequent shrinkage is that of an isolated mass at the center where no additional material is available to fill the volume left by the shrinkage. The result is a single large void at the center of the casting.

In a cast charge (unlike in a pressed charge), both density and pore or cavity size are determined by the casting procedure. Both of these factors must be considered by the designer in terms of their effects upon safety, reliability, and performance.

*b. Crystal Size.* The crystals of TNT in cast explosives may vary from microscopic size to a substantial fraction of the size of the charge, depending upon casting conditions and procedure. The approach known as cream casting (Paragraph 80) results in very fine crystals. In mixed explosives, which usually are cast in the form of slurries, the solid particles tend to inhibit crystal growth, although TNT crystals sometimes apparently grow around the particles of the slurry. The effects of particle size on initiation sensitivity, failure diameter and performance characteristics (see Paragraph 27), have also been observed to apply to crystal size in cast TNT.

*c. Uniformity of Composition.* Most castable explosives are poured as slurries of RDX, aluminum, etc., in molten TNT. The instant a charge is poured, the particles of higher density than TNT start to settle, and those that are lighter start to rise. As a result, by the time the material solidifies, its composition varies from point to point within the charge. Another cause of nonuniformity of composition is the tendency of TNT to form essentially pure crystals, leaving other components of the mixture at grain boundaries and in the center of the charge which usually solidifies last. The most serious production problem of this kind is the settling of aluminum in larger charges of aluminized explosives. The use of aluminum and other additives in very fine particle sizes can help to alleviate this problem but also tends to increase pouring difficulties because of the higher viscosities of the melts.

### 93. Standard Casting Procedure

The most common procedure for filling a projectile or bomb case is to do so in a single pouring.<sup>2</sup> A funnel or sprue provides a reservoir of molten explosive to fill the volume left by the shrinkage. The explosive in the funnel must, of course, remain liquid and in communication with the center of the charge. When the filling hole is large enough, convective heat transfer maintains such conditions. In other cases, however, such conditions can be maintained only by means of steam heated funnels, steam finger or hot probes.

Where the maintenance of a clear channel between sprue and the slowest freezing part of a charge is impractical, cavitation is avoided by casting charges in layers, each of which is allowed to solidify before pouring the next.

TNT melts at 81°C. It forms eutectics with RDX, tetryl (68°C), and PETN (76°C) and dissolves these materials at higher temperatures. Thus, there is a general tendency for the solids content and, hence, the apparent viscosity of most castable mixtures to decrease as the temperature is increased. However, a reversal of the tendency toward the reduction in viscosity has been noted in Composition B when it is heated above 100°C.

From the eutectic or melting point, the composition of the liquid portion and its viscosity vary as heat is removed. It has been recommended that the heat content of any explosive be reduced, before pouring, to the minimum compatible with the avoidance of air entrainment. This practice can be followed when an experienced operator is available.

TNT may be cast after it has cooled to a point where a fairly large fraction of it has solidified to form a slurry of very small crystals. Such a slurry is obtained by stirring it as it cools, as in the making of chocolate fudge. TNT cast in this manner is labeled by some as creamed TNT. Some have applied the term creamed to all explosives which are cast after stirring until the last possible instant. Extreme caution must be taken to avoid air entrapment during stirring.

### 94. Some Special Casting Techniques

*a. Pellet Casting.* For very large charges, cooling time is reduced and shrinkage minimized by use of precast pellets. The best pellet casting technique is that of pouring a quantity of molten explosive into the case, and then pouring in pellets, slowly enough so that they are not in contact with one

another to avoid entrapping interstitial air.<sup>2</sup> Although pellet casting reduces the total amount of shrinkage voids, it makes it nearly impossible to maintain channels to the pockets of molten material. The most important advantage of pellet casting is the reduction of cooling time in large charges.

*b. Vacuum Melting and Casting.* Entrainment of air may be avoided by melting and casting under a vacuum. Vacuum melting is a fairly straightforward procedure in the vacuum kettles which are maintained by many loading facilities (see Fig. 74). Vacuum casting requires specially designed molds or a vacuum chamber large enough to contain both kettle and mold. A divergence of opinion exists regarding the value of vacuum melting followed by pouring in air. Some investigators report results nearly as good as those obtained with complete vacuum melting and casting. Others maintain that

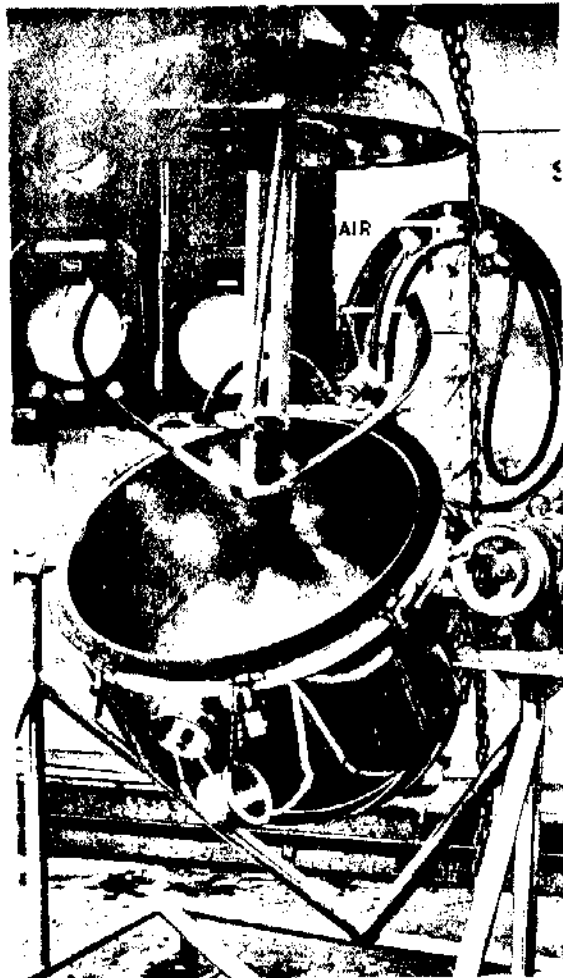

Figure 74. Vacuum Casting Kettle

so much air is entrained in the casting process that the value of vacuum melting is negligible. A possible explanation for this difference of opinion is the difference in techniques which can be applied in various types of operation.

*c. Vibration, Jolting and Centrifugal Casting.* Accelerating of a cast charge after pouring but before solidification will often expedite the movement of air bubbles to the surface.<sup>3</sup> Vibration and jolting often break the surface tension which causes bubbles to cling to surfaces.<sup>2</sup> Centrifugal acceleration, of course, also accelerates the settling of denser components of mixtures.<sup>2</sup>

*d. Controlled Cooling.* If an explosive charge can be induced to cool from the bottom up, maintaining a nearly plane interface between liquid and solid, densities well in excess of 99 percent of maximum theoretical are attainable. In a complicated programmed cooling, the thermal cycle of preheating the mold, pouring, and cooling takes over forty hours.<sup>4</sup> At the other extreme is the use of strategically placed insulation to cause a charge to cool in the approximate desired pattern.

## B. PRESSING

### 95. Standard Procedures

*a. Measurement of Explosive Charges.* For small test quantities or for some premium quality production, direct reading one-pan balances are used. They are faster than analytical balances and provide an accuracy within one percent. Automatic weighing machines are also available.

The desire is always to load a specific weight of explosive. This objective can be achieved to a sufficient degree of accuracy for many purposes by volumetric control, as in commercial blasting caps and squibs. The two most common volumetric measuring devices are scoops and charging plates. Scoops (Fig. 75) are filled and leveled against a rubber band. Careful scooping is accurate within 4%. Charging plates (Fig. 76) lend themselves to production rates. After filling holes in the top plate and scraping off the excess, plates are aligned with cup holes. Since explosive quantities are usually specified by weight, it is left to the loading plant to adjust the volume measured so as to take into account bulk density.

*b. Direct Pressing in Case.* A large proportion of explosive charges are loaded by direct pressing of

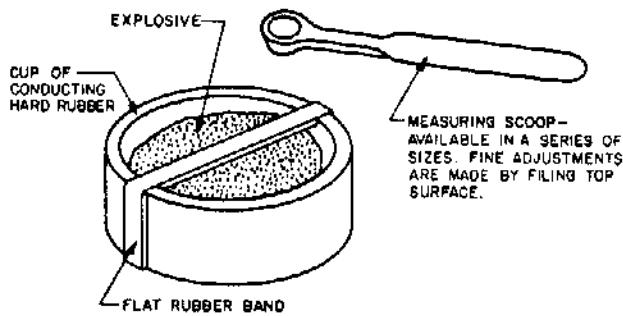

Figure 75. Scoop Loading

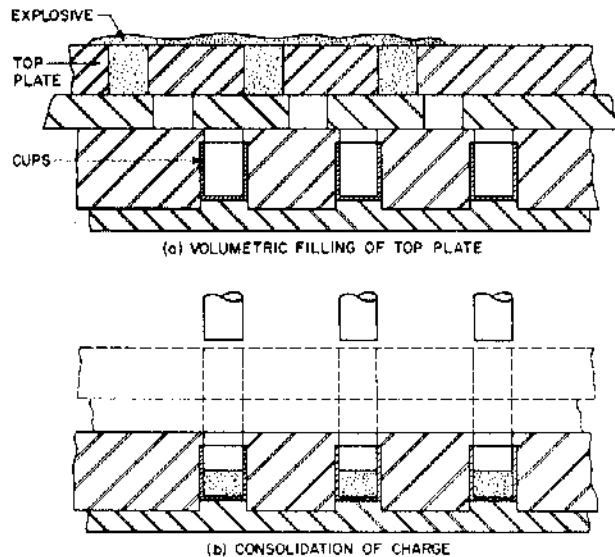

Figure 76. Charging Plate Loading

explosive charges in cases (Fig. 77)<sup>4</sup>. Fits and tolerances of explosive charge cases and loading tools are determined by reconciliation of three opposing factors

(a) Production costs of components rise sharply as tolerances are reduced.

(b) Powdered explosives tend to flow into the clearance between ram and case. In addition to creating a hazard, the explosives wedged in this space can increase the frictional resistance to ram movement, and substantially decrease real loading pressure.

(c) Interference between ram and case results in binding (which may be so severe as to prevent any pressing of the explosive), damage to the case, inclusion of chips of case material in the explosive, or all of these.

The cost of a set of loading tools may be distributed over a large number of items. For this reason, they are often made to fits and tolerances similar to those used for gages.<sup>5</sup> Where cases are

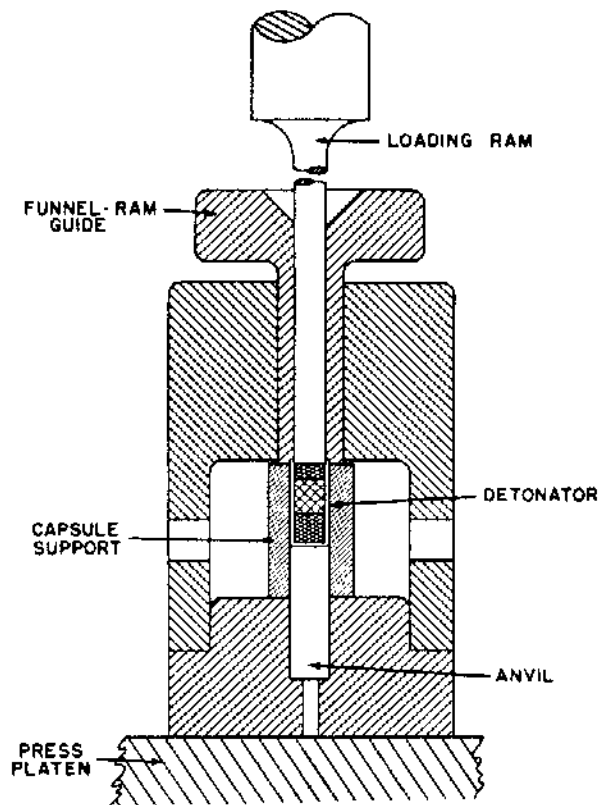

Figure 77. Detonator Loading Tool

made by processes such as forging, drawing and extrusion, which use most of the tolerance in lot-to-lot variation, some loading activities have found it worthwhile to maintain a series of loading tools of graduated dimensions, utilizing those giving the best fit possible with each lot of cases.

Production loading tools should be hardened (60 Rockwell C is common). The die should be ground, honed and lapped or polished to an 8 or 16 rms micro-inch finish. Some claim better results if the final operation involves longitudinal rather than rotary motion.

The friction between the explosive and the walls causes a gradient of pressure, and hence density, decreasing from the face of the ram. The slope of this pressure gradient, of course, is proportional to the coefficient of friction between the explosive and the walls, which varies with both explosive and case material and also with the interior finish of the case.<sup>4</sup> As a general rule, the density variations due to these gradients are kept within reasonable bounds by adherence to the general rule-of-thumb that the length of an increment after consolidation should not exceed the diameter of the cavity.

The usual loading pressure of about 10,000 psi is well beyond the bursting strength of charge cups of any material which can be economically deep drawn. Hence, cups are supported by close fitting loading tools while being pressed. Most of the difference between the cup diameter before and after loading is accounted for by the expansion of the explosive component, relieving residual stresses, as it is pushed out of the tool. For this reason, loading tools should be made to fit the maximum outside diameter of the cup, within a few ten-thousandths of an inch. Standard dimensions and tolerances of cups are listed in MIL-STD-320.<sup>c</sup> Bore finish and hardness of the bushing are important factors in trouble-free ejection of finished cups. Lapped or honed bores are often specified. Where cases are heavier or where explosives are to be loaded directly into fuze cavities, the interactions of case and tool tolerances, which may be sufficient to cause interference between the ram and any of the bores through which it passes, should be considered carefully. In some situations, where explosives are to be loaded directly into fuze holes, the most practical way to attain alignment is to use a pin or dowel, similar to the loading ram, to hold the component in alignment with the ram guide while it is being clamped in place. It is best to use an alignment pin a thousandth of an inch or so larger than the loading ram. Figure 78<sup>a</sup> shows a set-up for hand loading of leads making use of an alignment ram and a mandrel.

*c. Stop vs. Pressure Loading.* In production, it is possible either to press a controlled quantity of explosive to a controlled height (called stop loading) or to apply a given load to a loading ram of a given diameter (called pressure loading). The inherent variations in production material introduce a certain

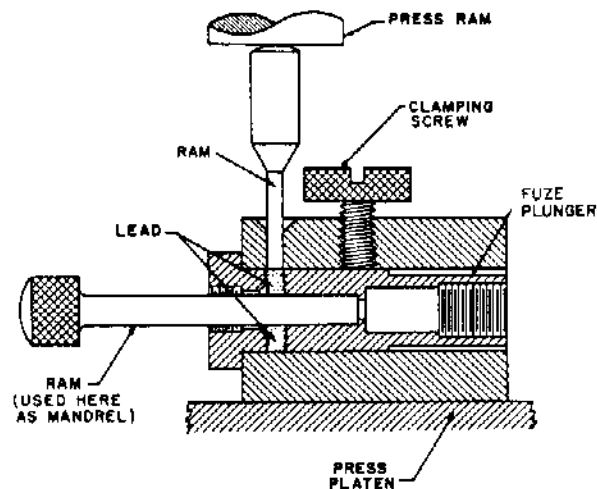

Figure 78. Tool for Direct Loading of Component

amount of error in the density obtained by either method.

The relationship between loading pressure and charge density for commonly pressed explosives is given in Table 37.<sup>a</sup> An approximation of the loading densities of six commonly used explosives is shown in the nomograph, Fig. 79<sup>b</sup>. The pressure-density relationship varies somewhat from lot to lot. In addition, loading density is affected by such factors as ram clearance and increment length.

From the usual cup tolerances, it has been calculated that the cross-section area of the explosive column of a detonator may vary by two or three percent. In normal production, a reasonable weighing tolerance for initiator charges is three or four percent. Thus, in stop loading, assuming that the height of an increment is exactly reproduced, the density may vary as much as seven percent.

The implication of the foregoing, that densities are more readily controlled by the control of loading pressure than by stop loading, has been borne

TABLE 37. LOADING DENSITY OF VARIOUS EXPLOSIVES

Explosive	Pressed (pressure Kpsi)						Cast	Crystal Density
	3	5	10	12	15	20		
Composition A-3	1.47	—	1.61	1.65	—	—	—	—
Composition B	—	—	1.59	—	—	—	1.67	—
Cyclonite (RDX)	1.46	1.52	1.60	1.63	1.65	1.68	—	1.82
EDNA (Haleite)	—	1.39	1.46	—	1.51	1.55	—	1.71
Explosive D	1.33	1.41	1.47	1.49	1.61	1.64	—	1.72
Lead Azide	2.46	2.69	2.98	3.05	3.16	3.28	—	4.68
(2 specimens)	2.62	2.71	2.96	—	3.07	—	—	—
Lead Styphnate (Norm.)	2.12	2.23	2.43	2.47	2.57	2.63	—	3.1
Pentolite, 50-50	—	—	1.59	—	—	—	1.65	—
PETN	—	1.48	1.61	—	—	—	—	1.76
Picric Acid	1.4	1.5	1.57	1.59	1.61	1.64	1.71	1.76
Picratol, 52/48	—	—	—	—	—	—	1.62	—
Tetracene	1.05	1.22	1.33	1.37	1.41	1.48	—	4.72
Tetryl	1.40	1.47	1.57	1.60	1.63	1.67	—	1.73
TNT	1.34	1.40	1.47	1.49	1.52	1.55	1.59	1.65

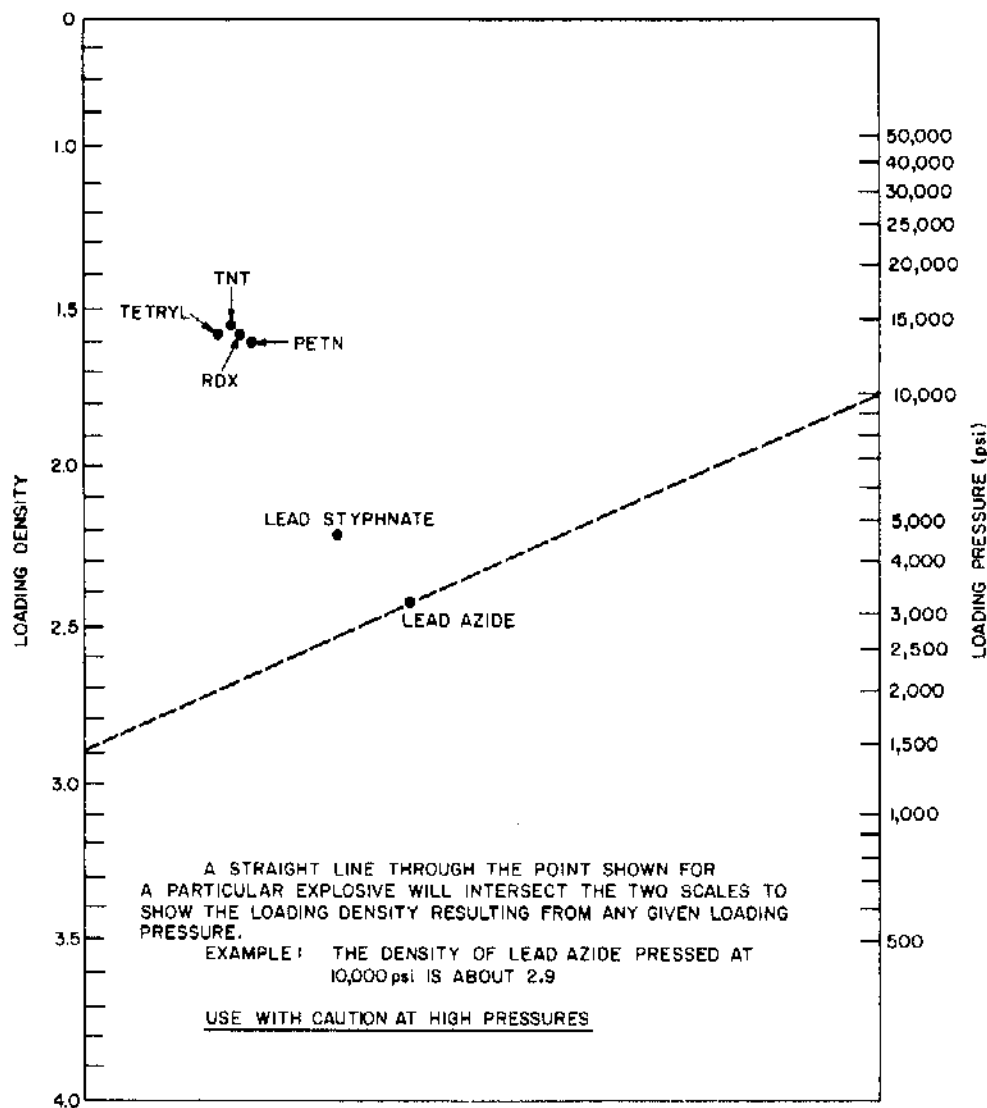

Figure 79. Nomograph of Loading Pressure-Density

out by experience. However, the production advantages of stop loading are sufficient to outweigh any theoretical disadvantages. It is important for stop loading to specify dimensions, quantities, and tolerances such that the maximum pressure is within limits imposed by tool strength. When items so loaded are used, safety and reliability determinations should take the effects of variable charge density into account. In either type of loading, a check of the loading density for each production lot is highly desirable.

When density is determined by pressure loading, variation in pressure, cross section area and charge weight each have an effect upon the column height. Usually, the length tolerances specified cannot be held merely by holding the various

quantities mentioned within their tolerances. The weight of explosive must be adjusted to compensate for the other variables. Commonly, the last charge loaded is adjusted to fit the space remaining for it and the weight is specified as "approximate."

In addition to the pressing properties of the explosive as such, the relationship between loading pressure and density is affected by such factors as ram movement, clearances, increment size and the coefficient of friction between explosive and case. The movement of the ram affects the relationship in two ways.

The first effect may be very serious. Where a balance or dead weight is used to determine the loading pressure, a rapid ram movement can result in a force due to acceleration of the masses moved

which may vary from a substantial fraction to several times the force due to gravity. Analyses of some loading operations have revealed that the true loading pressure was three or four times that intended.

The second effect of ram movement usually works in the opposite direction (slower ram speeds plus a dwell at the peak pressure may cause an increase in density). This effect is due to the fact that, at loading pressures usually used, explosives are stressed beyond their yield points and creep or flow plastically. This effect, of course, becomes more important at very high pressures, such as those used for delays. In addition to increasing the density, slower speeds plus dwell of the ram result in a more uniform density.

*d. Pelletizing.* Most powdered explosives which are to be pressed, are prepressed into pellets. The die of the loading tool permits closer tolerances and better finishes than are reasonable for cases which are loaded by direct pressing.

Although pellets for experimental use are loaded by single operation methods, in which weighed charges are pressed either by stop loading or by controlled pressure techniques, quantity production of pellets is accomplished in automatic pelleting machinery, in which the explosive is metered volumetrically by the controlled movements of punches (Fig. 80). Single stroke presses of the types used for explosives produce about 90 pellets per minute while rotary presses have rates of about 700 pellets per minute.

The density gradient resulting from wall friction, in addition to its effects on explosive performance, may adversely affect the handling properties of pellets. Pellets consolidated from powders at low densities tend to be weak in two ways: their resistance to body fractures is often less than desirable and they may crumble at corners and chalk off at surfaces. On the other hand, some materials become brittle and develop residual strains at high densities.

The effect of density variation on mechanical properties of pellets may cause difficulties even though the variation in explosive properties is tolerable. On the other hand, the general superiority of the finishes of pelleting molds over those of charge cases, and the use of double acting loading equipment, result in somewhat smaller density gradients in pellets than in direct loaded explosives. The result of these counterbalancing trends is that the one-to-one limiting ratio of length to diameter



SINGLE PUNCH

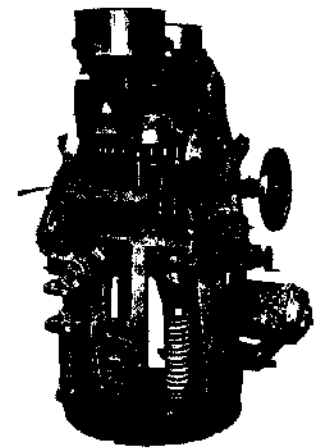

ROTARY

Courtesy  
F. J. STOKES CORP., PHILA.

Figure 80. Pelleting Presses

which applies to increment loading also applies to pellets. For some materials, somewhat shorter pellets are desirable, particularly in larger sizes.

The diameter of a pelleting die may be maintained to almost any tolerance specified. Similarly, the distance between the top and bottom punches of an automatic pelleting machine, or the punch-to-heel distance in a stop pressing tool, can be held to any desired tolerance. Thus, the dimensional variations are essentially the variations in expansion of the material, during and after ejection from the die. The immediate expansion upon ejection for a typical explosive used for pressed pellets is about 0.3 percent. Pellet-to-pellet variations are usually less than 0.1 percent but the expansion continues with storage at a rate which varies appreciably with conditions as well as with the composition of the explosive. Pellets of an explosive of known expansion characteristics, which are to be inserted into cups within a few hours after pelleting, may be held to dimensional tolerances of the order of 0.1 percent or less. However, tolerances of 0.3 percent to 0.5 percent are more practical.

Variations in density reflect variations in dimensions with those of the bulk density and flow characteristics of the explosive, and those of the measured volume. With frequent pellet density determinations and occasional adjustment of the pelleting press, explosives with good flow properties can be pressed into pellets reproducible in density to one percent in an automatic pelleting press.

*e. Reconsolidation.* Frequently, when it is desirable to attain the close confinement and continuity characteristic of explosives loaded directly into their cases, it is difficult or inconvenient to do so. In such instances, pellets are inserted into the cavities and reconsolidated by pressing. In designing for reconsolidation, consideration must be given to the tolerances and variations of hole dimensions, pellet weight and pressure-density relationship that enter into the determination of the relative location of the surface through which the reconsolidation pressure is applied. Where this dimension is critical, the reconsolidation is done to a stop so that the tolerances appear in the density of the reconsolidated pellet. When reconsolidation is specified, the effects of these variations upon performance should be considered.

### 96. Special Procedures

*a. Vacuum Pressing.* In the usual pressing operation, in which a granular explosive is pressed from a bulk density of about half the crystal density to about 95 percent of the crystal density, the pressure rise in the interstitial gases (assuming isothermal compression and no leakage) may be in the neighborhood of 200 pounds per square inch. The air may be presumed to diffuse out of the pellet, through the continuous pores, quite rapidly after the pellet is ejected or the ram is removed, if it has not already leaked through the clearance between ram and cavity during pressing.

When densities reach 99 percent of crystal density, the calculated pressure of the interstitial gases rises rapidly, limiting attainable densities. When under conditions of pressing the explosive or some component of it is caused to flow plastically, the pores may be closed into individual bubbles in which the compressed gases are retained to cause excessive growth after pressure removal. In an open pore material, the relatively mobile gases tend to increase density gradients by distributing pressure without a correspondingly even distribution of the solid explosive. For these three reasons, vacuum pressing is used where very high or uniform densities are required, or where significant plastic flow is anticipated during pressing.

Figure 81<sup>1</sup> is a diagram of a vacuum loading tool. First, lower and top punches are advanced to a prepress position to compact the powder slightly. After evacuating to 1 mm Hg, full pressure is applied. Production of extremely high quality charges of TNT (pressed at elevated temperature)

and Composition A-3 (both at elevated and room temperature) have been reported.<sup>4</sup> Density spreads within six-inch diameter charges are 0.005 gm/cc.

*b. Hot Pressing.* The unique properties of plastic bonded explosives are realized most fully if they are pressed at elevated temperatures. Appropriate temperatures are, of course, determined by the properties of the plastic bonding agents used and limited by the thermal instability of the explosives.

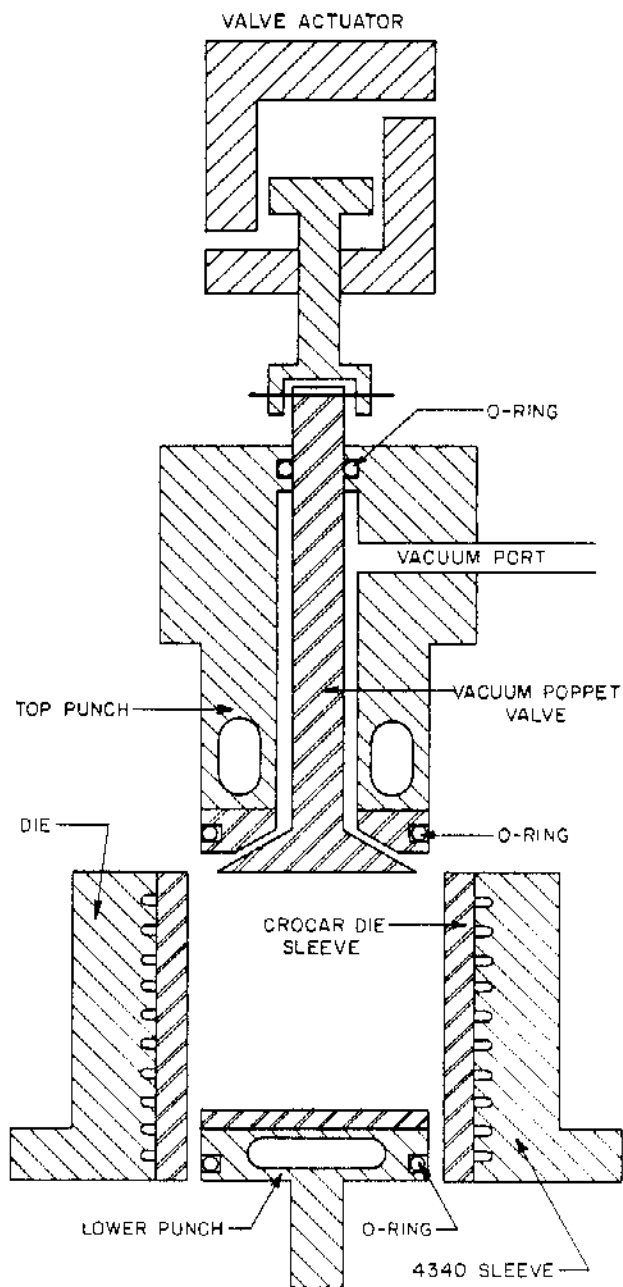

Figure 81. Vacuum Pressing Apparatus

Temperatures as high as 130°C have been used.<sup>7</sup> When heated to temperatures approaching their melting points, explosives and additives used in explosives, like most solids, are more prone to plastic flow. Equipment required for hot pressing of PBX has been found useful in the production of high density charges of conventional explosives. TNT is pressed routinely to a density of 1.62 in the vacuum pressing process described above at 70°C, whereas cast densities this high are unusual.<sup>4</sup> Preheating of the explosive is more efficient than waiting for it to heat in the mold but cannot be used when thermosetting resins serve as binder.

*c. Hydrostatic and Isostatic Pressing.* When an explosive is pressed in a die by means of a ram, the friction of the walls tends to cause pressure and density gradients. In addition, the one-dimensional compression can result in an anisotropic structure and produce pellets with residual strains. Where dimensional stability, uniformity and high density are essential to performance, hydrostatic and isostatic pressing have been used. In both of these processes, the explosive is compressed by the action of a fluid, from which it is separated by a rubber (or other elastomer) film.

In hydrostatic pressing, the explosive is placed on a solid surface and covered with a rubber diaphragm (Fig. 82). Although this process eliminates the gradients which result from wall friction, some directionality of compression remains which can result in anisotropic structure and residual strains. In isostatic pressing, the explosive is placed in a rubber bag (Fig. 83) which is surrounded by the pressurizing fluid so that the compression is essentially three dimensional.

In addition to the production of high quality charges, hydrostatic and isostatic pressing can be used to consolidate explosives which are so sensitive that frictional contact with the walls of a conventional mold creates a hazard. Materials like pure RDX, of which it is difficult to make firm pellets except in small sizes, can often be pressed hydrostatically or isostatically.<sup>7</sup>

Hydrostatic and isostatic pressing is usually applied to explosives which have been evacuated, frequently at elevated temperatures. Temperatures up to 130°C and pressures up to 30,000 psi have been used. The surfaces where pressure is applied through elastic membranes are, of course, of relatively poorly defined form and dimensions. Hence, these pressing processes must almost invariably be followed by machining.

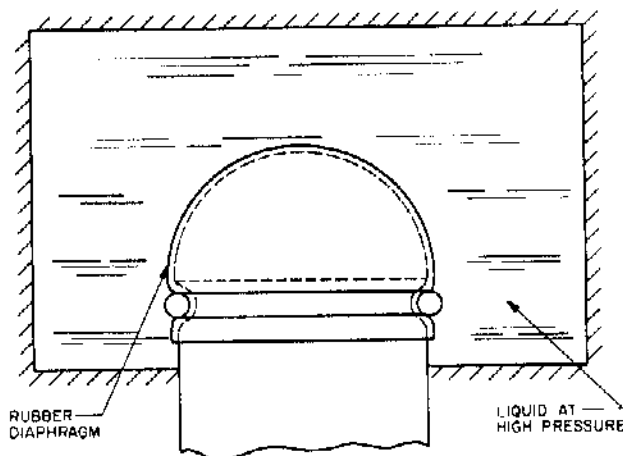

Figure 82. Hydrostatic Press Principle

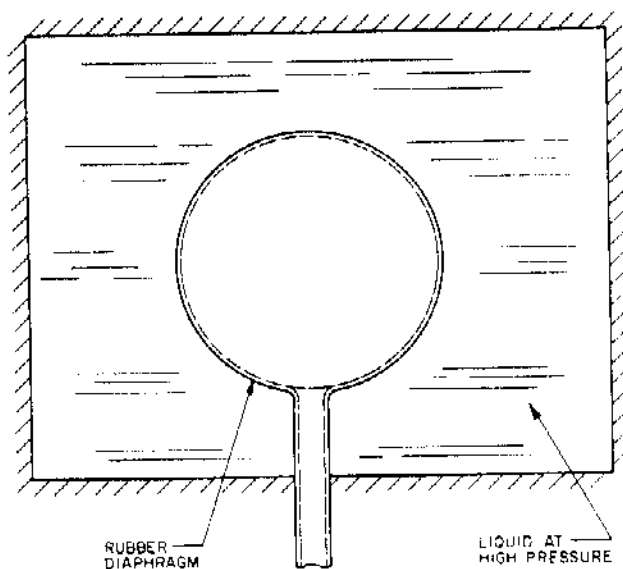

Figure 83. Isostatic Press Principle

*d. Pulsating Pressures.* Experiments have shown that pressures which pulsate with an amplitude of a few percent of the static pressure and at a frequency of about sixty cycles per second, when used with conventional molding tools, make it possible to produce pellets four or five diameters long with negligible density gradients. The interesting possibilities of this technique in production of explosive charges have not yet been exploited.

## C. FINISHING OPERATIONS

### 97. Machining

It has been found that the most uniform densities and compositions are attained by pressing



or casting relatively large charges, and machining the charges needed from selected segments. Similarly, high quality charges can be made by isostatic or hydrostatic pressing, which also must be followed by machining operations. All standard machine shop operations, including milling, drilling, sawing, boring, and turning, are applied in this work.

Many cast loaded items are filled through the same hole as that into which the fuze is to be inserted. After casting, the sprue is broken off. Although it is a good plan to design the funnel to form a core for the fuze cavity, the problem of funnel extraction limits this practice to some extent. At best, then, the bottom of the fuze cavity is a rough, broken off surface and, generally, the cavity isn't as deep as desired. The boring of fuze cavities to the specified depth and surface finish is a routine operation of production.

Profile lathes and forming tools may be used to form almost any desired surface of revolution. The special forms required for detonation wave shaping and other specialized output are often generated by such means. Explosives may be machined to the same tolerances as metals. Turning and milling to a thousandth of an inch is not difficult with a good machine. However, the practical applicability of such precision is limited by the dimensional instability of most explosive materials.

Safety is an important aspect in machining explosives. Since, as pointed out in Paragraph 20, the sensitivity of an explosive has meaning only in terms of the specific initiating impulse, the practice mentioned of machining each explosive material by remote control at ten times the surface speed to be used in charge fabrication is most desirable.<sup>1</sup> On the basis of this test, it is considered safe to machine Composition A-3, Composition B, and TNT at 200 ft/min surface speed.

Cut-off tools and small drills are more hazardous because of the poor cooling conditions. These operations, if necessary, should be performed at low speeds with intermittent cutting and frequent flushing. Water should be used wherever practical as a coolant, although tests at high speed under dry conditions are considered justification for dry machining where needed. The water keeps explosive dust out of the air and cools the cutting operation.

#### **98. Cementing of Compound Charges**

Explosives charges made of more than one explosive, in which the contour of the boundary is

an important design parameter, are often fabricated from cast, pressed or machined components which are cemented together.

Cements which harden by the loss of solvent are generally to be avoided because the solvent can be lost only by diffusion through the explosive. Diffusion may be slow and the solvent may modify the properties of the explosive. Two types of cement which have been used for this purpose are catalytic setting cements, like epoxy resins, and contact cements. Compatibility of the materials to be used should be checked. Compatibility of epoxy resins with most explosives depends upon the catalyst or hardener used.<sup>8</sup> Data regarding bond strengths and other pertinent properties have also been compiled.<sup>9,10</sup>

Both surfaces to be cemented should be clean and fit accurately to one another. A minimum continuous layer of cement should be applied to each surface to be joined. Where catalytic resins are used, provision should be made to hold the members in firm contact for the curing period. When contact cements are used, mechanical means are desirable to assure that the elements are in the proper position and orientation when they make the first contact.

#### **D. SUITABILITY**

##### **99. Availability**

The criteria upon which explosive materials and fabrication processes must be chosen are suitability for use in ordnance, availability, and suitability for a particular application.

Some materials and techniques are inherently more expensive than others and should be applied only where the advantages to be gained are clearly worth the added cost. In this respect, it is well to remember that such costs are reflections of demands on specialized manpower and strategic materials so that, in a total war, they represent proportional fractions of the total available military potential. In other cases, the most suitable materials and techniques are so new as to be available only for laboratory quantities of items.

Availability of an explosive involves more than the existence of plant capacity and raw materials suitable for economical production. The material must have been approved for military use and quality control criteria must exist. Government policy discourages the use of proprietary materials, especially those protected by trade secrets.

Most explosives of military interest with their properties and other details, are listed in References *g* and *h* given in Paragraph 12 (end of Chapter 1). The existence of a Purchase Description or Specification may be taken as evidence of the general availability of a material for military use. These purchase documents contain many details about the explosive including quality control criteria.

The production of a high explosive compound usually requires a specialized and often elaborate plant. Before specifying a compound or a mixture, the designer should assure himself that the necessary plants exist or will exist at the time the item he is designing reaches the production stage.

Mixtures are more easily made and generally require only the simplest apparatus. In a sense, the availability of a mixture may be considered that of its ingredients. The prevalence of this viewpoint is the reason many mixtures have been specified only by notes on drawings giving their compositions. Mixtures so specified usually perform satisfactorily. However, the properties of mixtures, particularly their sensitivities, may be affected by the mixing procedures. Also, in the absence of specified procedures and quality controls, mixtures may be less uniform than desirable. For this reason, some take the view that each mixture is a unique explosive. Whenever possible, it is wise to use mixtures which have been standardized.<sup>g,h</sup> The most common mixtures are listed in Table 39 while priming compositions are shown in Table 27.

The preceding paragraphs of this chapter describe casting, pressing, and finishing operations and, hence, indicate the kind of facility which must be available for fabrication.

#### 100. Output Characteristics

Explosives differ from other forms of stored energy in that the rates at which they liberate energy as well as the forms in which it is liberated are less subject to control by design and more uniquely by properties of the materials in which the energy is stored. For this reason, the total amounts of energy liberated in their reaction, although of importance in evaluating explosives, is not necessarily a final criterion of relative effectiveness in any particular application. Other properties, such as the detonation velocity or detonation pressure, combine with energy to define the effectiveness of an explosive. A number of these properties are tabulated in Table 38 for explosive compounds and in Table 39 for explosive mixtures.

Although the effectiveness of an explosive material in any particular application is the result of the interaction of quantities such as those listed in Tables 38 and 39, quantitative calculation of effectiveness in various applications is difficult and often impossible. Some of the quantities are directly determined by composition. Others are affected by the state of aggregation of the explosive which is, in turn, partly determined by loading techniques and conditions.

The aspect of the state of aggregation which has the most effect upon output is loading density (see Paragraphs 27 and 95). In general, the effects of density are greatest in applications such as fragmentation and, in particular, shaped charges where the detonation pressure is an important factor.

#### 101. Sensitivity

The term sensitivity is often applied as if it were some fundamental property of an explosive like its melting point. The fact is that sensitivity test results are meaningful only in terms of the test method employed (see Paragraph 26). If one considers the complex series of events and the many factors involved in the initiation process, this is hardly surprising.

Sensitivity tests which are of interest to the designer are of two types: (a) general laboratory tests, chosen for convenience, reproducibility, and correlation with experience, whereby the sensitivity of various explosives to such stimuli as impact, friction, and static electricity, may be evaluated, compared, and ordered, (b) tests which are designed to simulate a specific hazard to which the explosives may be exposed. The results obtained in the two types of tests are tabulated in Tables 20 and 21. The various tests are described in Paragraph 107.

Some of the tabular data are directly applicable to the design of safe and reliable materiel. Other aspects of safety are not subject to quantitative evaluation or prediction. Predicting the abuse to which ammunition may be subject under extreme conditions of stress is a difficult task.

Even the more obvious data in the tables should be applied with caution. For example, given the maximum setback acceleration, it is possible to compute the maximum setback pressure by assuming the explosive to behave as a liquid and applying Pascal's Law. Comparison of this pressure with the setback sensitivity figures of Table 21

TABLE 38. FUNDAMENTAL CHARACTERISTICS OF EXPLOSIVE COMPOUNDS

Explosive	Crystal Density (gm/cc)	Melting Point (°C)	Heat of Combustion (call/gm)	Heat of Explosion (call/gm)	Gas Volume (cc/gm)	Detonation Velocity (m/sec)	Loading Density (gm/cc)	Detonation Pressure (megabar)	Failure Diameter <sup>a</sup> (in.)
Ammonium Nitrate	1.73	170	346	346	980	1000	0.9	—	—
Cyclonite (RDX)	1.82	204	2285	1280	908	8780	1.65	0.255 <sup>c</sup>	—
Diazodinitrophenol	1.63	157	3243	820	865	—	—	—	—
Explosive D (Ammonium Picrate)	1.72	265 <sup>a</sup>	2890	800	—	6850	1.55	0.145 <sup>c</sup>	—
Haleite (EDNA)	1.71	175 <sup>a</sup>	2477	1276	—	7570	1.49	0.173 <sup>c</sup>	—
Lead Azide	4.80	<sup>a</sup>	630	367	308	4600	3.0	0.922 <sup>c</sup>	—
Lead Dinitrosorcinat (LDNR)	3.2	265 <sup>b</sup>	—	270	—	—	—	—	—
Lead Styphnate	3.02	260-310 <sup>b</sup>	1251	457	368	5200	2.9	0.126	—
Nitroglycerin (Liquid)	1.59 <sup>c</sup>	2.2&13.2	1616	1600	715	8000 <sup>c</sup>	1.6 <sup>c</sup>	0.241 <sup>c</sup>	—
Nitroguanidine	1.72	232	1995	721	1077	7650	1.55	0.160 <sup>c</sup>	—
PETN (Pentaerythritol Tetranitrate)	1.77	141	1960	1385	790	8300	1.70	0.253 <sup>c</sup>	—
Picric Acid	1.76	122	2672	1000	—	7350	1.71	0.187 <sup>c</sup>	—
Tetryl	1.73	130	2925	1080-1130	760	7170	1.53	0.196 <sup>c</sup>	< 1/2
TNT (Trinitroloene) (Cast)	1.65	81	3620	1080	730	6825	1.56	0.170 <sup>c</sup>	1

<sup>a</sup> Decomposes<sup>b</sup> Explodes<sup>c</sup> From Ref. 11 by interpolation<sup>d</sup> From Ref. 12<sup>e</sup> Density of liquid at 25°C

TABLE 39. FUNDAMENTAL CHARACTERISTICS OF HIGH EXPLOSIVE MIXTURES

Explosive	Composition	Ratio	Density (gm/cc)	Melting Point (°C)	Heat of Combustion (call/gm)	Heat of Explosion (call/gm)	Gas Volume (cc/gm)	Detonation Velocity (m/sec)	At Loading Density (gm/cc)	Detonation Pressure (megabar)	Failure Diameter <sup>c</sup> (in.)
Amatol	NH <sub>4</sub> NO <sub>3</sub> /TNT	80/20	1.46	<sup>a</sup>	1002	490	930	4500	1.46	0.074	—
Amatol	NH <sub>2</sub> NO <sub>2</sub> /TNT	50/50	1.59	<sup>a</sup>	1990	703	855	6420	1.55	0.160	—
Baratol	BaNO <sub>3</sub> /TNT	67/33	2.55	<sup>a</sup>	—	—	—	—	—	—	1½
Composition A-3	RDX/Wax	91/9	1.65	—	1210	—	—	8100	1.59	—	< 1
Composition B	RDX/TNT/Wax	60/40/1	1.65	—	2790	1240	—	7840	1.68	0.243 <sup>b</sup>	< 1/2
Composition C-3	RDX/...	77/...	1.6	—	—	—	—	7620	1.6	—	—
Composition C-4	RDX/...	91/...	1.5	—	—	—	—	8040	1.59	—	—
Cyclotol	RDX/TNT	75/25	1.71	<sup>a</sup>	2625	1225	862	8030	1.70	—	—
Cyclotol	RDX/TNT	70/30	1.71	<sup>a</sup>	2685	1213	854	8060	1.73	—	—
Cyclotol	RDX/TNT	60/40	1.68	<sup>a</sup>	2820	1195	845	7900	1.72	—	—
Pentolite	PETN/TNT	50/50	1.65	76	—	1220	—	7465	1.66	0.233 <sup>b</sup>	—
Pentolite	PETN/TNT	10/90	1.60	76	—	—	—	—	—	—	—
Picratol	Expl. D/TNT	52/48	1.62	<sup>a</sup>	—	—	—	6970	1.63	—	—
Tetrytol	Tetryl/TNT	75/25	1.59	68	—	—	—	7385	1.60	—	—
Torpex	RDX/TNT/A1	42/40/18	1.79	<sup>a</sup>	3780	1800	—	7495	1.81	—	—
Tritonal	TNT/A1	80/20	1.79	<sup>a</sup>	4480	1770	—	6475	1.71	—	1

<sup>a</sup> Essentially the melting point of the TNT component (81°C)<sup>b</sup> From Ref. 11 by interpolation<sup>c</sup> Ref. 12

might be expected to give some measure of the safety of the weapon against bore prematures. However as pointed out in Paragraphs 35-42, the probability of such prematures is a function of a number of aspects of weapon design and loading procedure as well as the choice of explosive.

Hence, the data presented in Tables 20 and 21 are offered as aids to, rather than substitutes for, judgment of the designer in the choice of explosives which will result in safe and reliable ordnance.

## 102. Chemical and Physical Properties

The fundamental chemical and physical properties of explosives are, of course, important in determining explosive characteristics. These properties are listed in References *g* and *h* given in Paragraph 12 (end of Chapter 1). Aside from these, the most important chemical characteristics to the designer are the reactions of explosives with other materials with which they may come into

contact. For a condensation of compatibility data, including the more usual combinations, see Table 23.

An example of a compatibility problem is lead azide which is subject to a certain amount of hydrolysis in the presence of moisture. The hydrazoic acid formed reacts with most metals to form metallic azides. The safest practice is to avoid contact of azide with any metal except the preferred stainless steel and aluminum alloys.

Exudation is a phenomenon related to the chemical characteristics of TNT bearing explosives against which safeguards must be taken (see Paragraph 35). Because of the similarity of many of the impurities to the parent explosive, multiple component eutectics are formed which melt at ordinary storage temperatures and exude from the charge in an oily form.

Physical properties pertain to the structural strength of the explosive. Plastic bonded explosives were developed for their physical properties which are far superior to those of cast or pressed explosives.

## E. QUALITY CONTROL

### 103. Bases for Tolerances

Safety, reliability and performance of an explosive charge are determined by such design quantities as dimensions, composition and loading density. Limits or tolerances must be stated for each quantity specified. The designer's responsibility with respect to tolerances does not stop with the assurance that the specified tolerance will be satisfactory. It includes determinations of the maximum limits or tolerances compatible with requirements for safety, reliability, and performance. The tolerance specified should be determined in the light of the following considerations

(a) Production costs are inversely related to tolerance limits. The form of this relationship varies with quantity specified, complexity of the item, process used, and equipment available. Small tolerances should be specified only on the basis that the benefits which accrue are worth the cost.

(b) Where compliance with tolerances required for satisfactory performance is too expensive in terms of the cost and value of the item, an investigation should be made of possible design modifications to permit greater variations in the quantity considered.

(c) The measurement of quantities which may be specified in a design is limited in precision.

The designer will often be called upon to classify defects as critical, major, or minor, and to specify AQL levels for various defects. The basis and procedure for such classification and specification, as well as the sampling procedures which are used in inspection, are given in MIL-STD-414.<sup>13</sup> In essence, as applied to most explosive charges, critical defects are those which result in hazards to users, major defects are those which cause failure, and minor defects are those which do not materially affect usability.

### 104. Factors Affecting Quality of Explosive Charges

*u. Density.* The density of a pellet may be determined by measuring its dimensions with a micrometer and its weight with an analytical balance and calculating its weight-to-volume ratio. If it is impervious to water, the chemist's method of weighing in air and in water can be used. Both of these methods are somewhat slow for repetitive operations, such as those of quality control. For impermeable charges, one of the most convenient means of checking density is the preparation of two solutions of a dense salt, one of a density equal to the upper limit and the other at the lower limiting density. If a pellet floats in the former and sinks in the latter, its density is within the specified tolerance.

The density of a cased charge may be determined by weighing the case empty, filled with water and after loading. The density in gm/cc is then the ratio of the net explosive weight to the net water weight. This method becomes impractical for small cased charges like those of leads and detonators. Here, the density may be determined from the weight as determined by weighing the case before and after loading, and from the volume as calculated from the dimensions.

A scheme for continuous quality control is that of pressing at some constant pressure or dead load and measuring the intrusion of the ram in each item. Variations in cavity dimensions, charge weight, or pressure-density relationship can be detected by this method. Of course, the method is incapable of distinguishing between these variations, and errors of one kind can compensate for errors of another. However, in a well controlled process, the probability of each type of error is low enough that the probability of simultaneous occurrence, either compensating or not, is negligible. The type of data to be collected in each case, to avoid erroneous conclusions, can usually be determined by study of the problem.

b. *Crack and Cavities.* In cast charges, the possible presence of cracks and cavities cannot be ruled out. Such defects can be detected by means of X-ray photographs. When such inspection is called for, as it should be in most cases, a defect classification chart should be prepared, including full scaled illustrations of minor, major, and critical defects. Such classification should be based on quantitative determinations of effects of defects on safety and performance. X-rays should be made in at least two charge orientations.

c. *Composition Variation.* When homogeneity is critical, determinations of density and composition from point to point within a charge are made from samples obtained by sectioning the item.<sup>14</sup> This is a destructive test, at least for the explosive charge itself, and can be done only on a sampling basis. Variations in aluminum content of aluminized explosives may be detected in the X-rays which are made to detect cracks and cavities.

## REFERENCES

### CHAPTER 10

a-i Lettered references are listed in Paragraph 12 (end of Chapter 1).

1. D. Kite, Jr., A. K. Behlert and E. Jercezewski, *Plastic Bonded Explosives for Use in Ammunition (U)*, Picatinny Arsenal Technical Memorandum 2-2-62, March 1962 (Confidential).
2. M. J. Margolin and E. A. Skettini, *Ammunition Loading Techniques*, Picatinny Arsenal, Explosives Development Section, Report 43, December 1958.
3. G. D. Clift, *Centrifugal Casting of Explosive Charges for HEAT Shell*, Picatinny Arsenal Technical Report 2381, November 1956.
4. E. James, Jr., "Charge Preparation for Precise Detonation Velocity Studies," *Second ONR Symposium on Detonation*, Office of Naval Research, Navy Dept., February 9-11, 1955, pp. 1-17.
5. Engineering Design Handbook 248, Ammunition Series, *Inspection Aspects of Artillery Ammunition Design*.<sup>\*</sup>
6. *Explosion Effects Data Sheets*, Naval Ordnance Laboratory (White Oak), NAVORD Report 2986, June 1955.
7. C. C. Misener, *Capabilities of Explosive Loading Group of the Chemical Engineering Division (W.E.)*, Naval Ordnance Laboratory (White Oak), NAVORD Report 6873, 27 April 1960.
8. M. C. St. Cyr, *Compatibility of Explosives with Polymers*, Picatinny Arsenal Technical Report 2595, March 1959.
9. M. J. Bodnar, *Bonding of Explosives to Metal with Adhesive*, Picatinny Arsenal Technical Report 2412, June 1957.
10. M. J. Bodnar, E. R. Kelly and W. J. Powers, *Adhesive Bonding of High Explosives to Metals*, Picatinny Arsenal Technical Report 2538, August 1958.
11. E. A. Christian and H. G. Snay, *Analysis of Experimental Data on Detonation Velocities*, Naval Ordnance Laboratory (White Oak), NAVORD Report 1508, February 1951.
12. G. V. Horvat and E. J. Murray, *Propagation of Detonation in Long Narrow Cylinders of Explosives at Ambient Temperature and at -65°F*, Picatinny Arsenal Technical Report 2389, January 1957.
13. MIL-STD-414, *Sampling Procedures and Tables for Inspection by Variables for Percent Defective*, June 1957.
14. L. Jablansky and S. D. Stein, *Specific Gravity Study and Composition Analysis of Composition B-Loaded 77mm T30E2 Shell*, Picatinny Arsenal Technical Report 2338, February 1957.

<sup>\*</sup> See inside back cover for handbook designation.

## EVALUATION PROCEDURES

## A. CONSIDERATIONS IN EVALUATIONS

## 105. Safety and Reliability Procedures

*a. Statistical Inferences.* If each type of material could be perfectly made, its properties could be accurately described by measuring one of each type. Since this ideal can never be realized in practice, one can measure the properties of either every item or a sample which is truly representative of that type. The simplest, most direct and least questionable way to demonstrate the safety or reliability of an explosive charge is to test enough items under actual service conditions. This will enable one to determine the reliability or safety of the charge under actual conditions.

Absolute assurance can never be given unless all of the units are tested. A quantitative measure, however, can be obtained in terms of a probability which can be qualified with a confidence level. As an example, with a low failure rate  $\gamma$ , the number of trials  $n$  without a failure to establish (with 95% confidence) any specified reliability or safety level is

$$n = 2.3/\gamma \quad (37)$$

Thus, to establish 99.9% reliability at 95% confidence, it is necessary to test 2300 items without a failure, and to establish a safety of one explosion or less in a million exposures, 2,300,000 trials would be needed.

The designer's task, however, is to provide sound estimates of what can be expected in terms of safety and reliability with relatively few samples. To do so he must be able to recognize the significant parameters and treat the measurements on a sound statistical basis. Hence, the following discussion should be considered as a general guide. It should not be followed slavishly at the expense of sound engineering practice. It is strongly recommended that the reader supplement his background by studying the referenced texts.<sup>1-10</sup> A review of the

normal, binomial, and Poisson distributions would be particularly helpful. It is important to realize, on the other hand, that correct design of experiment and performance of statistically significant tests is a specialty which calls for the services of a qualified expert.

When computing safety and reliability by statistical extrapolations of sensitivity data, the following points will serve as a general guide.

(a) All safety and reliability determinations are estimates. As such, they should be accompanied by assessments of their accuracy and confidence levels.

(b) Safety and reliability determinations apply specifically to the conditions for which they were determined. It is part of the function of a designer to determine, as completely as possible, the range of conditions which may be expected to prevail in service and to assure himself of safety and reliability over the whole range.

(c) The surest way to establish safety and reliability is to test a large enough quantity under the exact conditions of use. The quantities necessary for such tests are, however, prohibitive, particularly in the design and development phase.

(d) *All fire* points are not what their name implies. The only way to be sure that all charges of a kind will fire under any given set of conditions is to fire them all under these conditions. When this is done, none will be left to use in ammunition. If *all fire* data are accompanied by a 50 percent point or a *no fire* point, and the numbers of trials involved in *all fire* and *no fire* determination are specified, they may be used with a statistical lever technique to compute safety and reliability levels.

(e) All extrapolations are based on assumptions, depending on the nature of the underlying distribution. Hence, predicted values should be accompanied by a clear statement of the assumptions made and, whenever possible, a justification for their use.

(f) The sensitivity of a charge is determined by its design and that of its surroundings, as well as by the explosive materials of which it is composed. Thus, safety and reliability must be re-evaluated when the design of either explosive charges or inert parts is altered. Seemingly small changes are sometimes important.

(g) Both safety and reliability are related to the ratio of the difference between the expected service condition and the mean sensitivity to the standard deviation of the sensitivity. Either may be improved by increasing this difference or by reducing the standard deviation.

(h) Although, as shown in Paragraph 20, the initiation process often depends upon the non-homogeneity of explosives, so that sensitivity is perhaps more inherently statistical in nature than most quantitative properties, it has been found that the variability of the sensitivity of most explosive charges is mainly due to variations in such quantities as dimensions, density, and confinement. Thus, the standard deviation of the sensitivity can usually be substantially reduced by improved control of such quantities.

*b. Frequency Distributions.* Observations will usually take the form of variables or attributes. Data consisting of measured characteristics are said to be expressed by variables. Attributes are specific qualities possessed by the item, such as color, cracked, fired, or not fired. Hence, in general, the item examined either conforms or does not conform to some quality standard or specification. Attributes in the form of *go* and *no-go* data, such as fired and not-fired, are often referred to as quantal response data; the event either occurs or does not occur upon the application of a stimulus. It is often advantageous to express the latter as a percentage of occurrence for a given stimulus which in effect is a means of transforming quantal data to a variable form.

One of the methods that can be used to present the results of a series of observations is a graphical plot of the frequency of each occurrence with respect to the independent variable. This plot is a visual display of the pattern of variation for the observations. With a graphical technique it is usually more convenient to plot the cumulative frequency as a function of the independent variable. An example of cumulative frequency distribution, the probability of functioning of an electric initiator, is shown in Figure 84a. So many types of experimental data fit a pattern of this type (also known as

a *normal* distribution) that a special graph paper (probability paper) is made on which this function will plot as a straight line (Figure 84b). When a distribution of observations fits such a pattern it can be described by its mean (the average or 50% value) and a standard deviation (the root mean square of the deviation from the mean).

There are cases when the data will yield a curve on probability paper as shown in Figure 85a. It is wise in cases of this type to find a suitable mathematical transform for the independent variable which will give a straight line to take advantage of the properties of the normal distribution which are well defined. The transform (or normalizing function) which has been successfully applied to

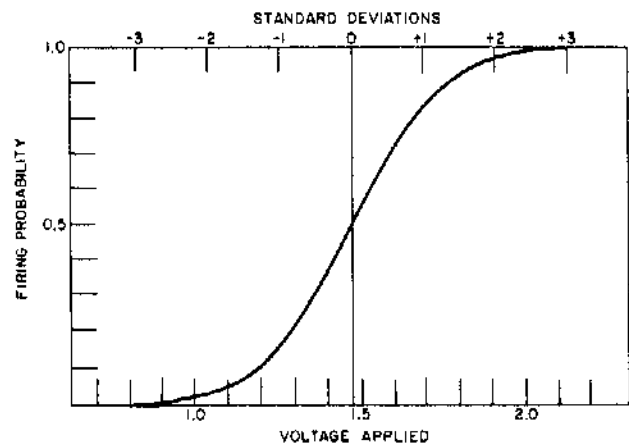

(a) DATA PLOTTED ON RECTANGULAR COORDINATES

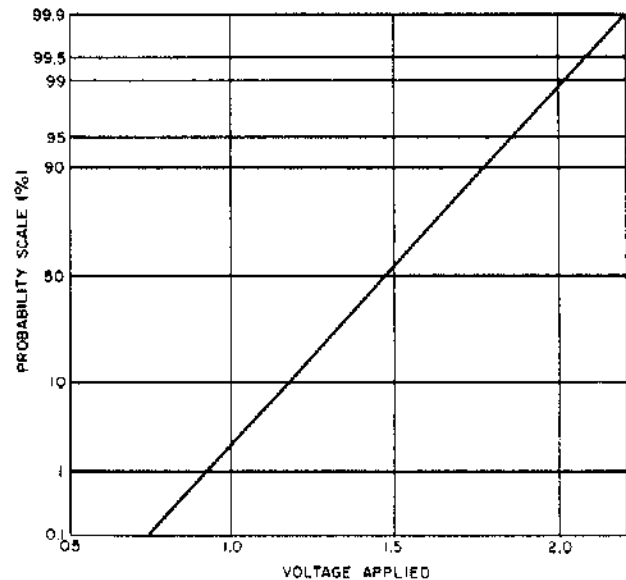

(b) DATA PLOTTED ON PROBABILITY PAPER

Figure 84. Cumulative Frequency Distribution for a Normally Distributed Population

input sensitivity is the logarithm of firing stimulus. Figure 85b. The probability that mechanical detonators will fire has been found to be nearly normally distributed with respect to the logarithm of drop height which is related to the energy required for functioning. The analogy also applies to initiation by another explosive charge, the probability of which is related to the logarithm of gap length. The logarithmic relationship has also been found to be useful for wirebridge electric initiators with respect to such energy parameters as current or voltage.

The assumption that statistical quantities are normally distributed, or may be made that way by the choice of a normalizing function of the physical variable, has formed the basis for most statistical methods and treatments. Most quantitative statements of the variability of experimentally determined quantities are in these terms. For this reason, we discuss the variables in terms of this assumption even though recent experiments have cast some doubt on its applicability to safety and reliability problems.

Probability paper may be used to extrapolate from experimental data to predictions of safety and reliability. Consider, for example, that 23 of 25 electric detonators of a given design fire when subjected to the discharge of a one-microfarad condenser charged to 50 volts and only one in 25 fires when the potential is reduced to 25 volts. Suppose that the firing circuit to be used in service uses a one-microfarad condenser which will be charged to at least 65 volts. Assuming that the firing probability of the initiator is normally distributed with respect to the logarithm of the firing voltage, the noted frequencies (92 percent and 4 percent) are plotted on log-probability paper versus the voltages at which they occurred (50 and 25 volts). A straight line plotted through these points gives the most probable relationship between firing voltage and reliability. When extrapolating this line to 65 volts, the most probable reliability is found to be 99.4 percent.

*c. Confidence Levels.* Although the most probable reliability, as indicated by constructions such as in Figure 85, is a valid estimate of the performance which may be anticipated, the true reliability has as much chance of being lower as it has of being higher. For purposes of system evaluation or operations analysis, it is necessary to quote reliabilities with confidence levels. Confidence levels are quantita-

tive statements of the reliance which may be placed upon the statement of a statistical quantity. In the foregoing example, it is certainly true that the 23 out of 25 which fired at 50 volts is exactly 92 percent of that group of 25. It is also obvious that, if this group is drawn from a lot of 1000, the fact that 92 percent of the sample fired does not establish 92 percent as the reliability of the whole lot at this level. There is a possibility that by a remote coincidence of selection, either the only 23 in the

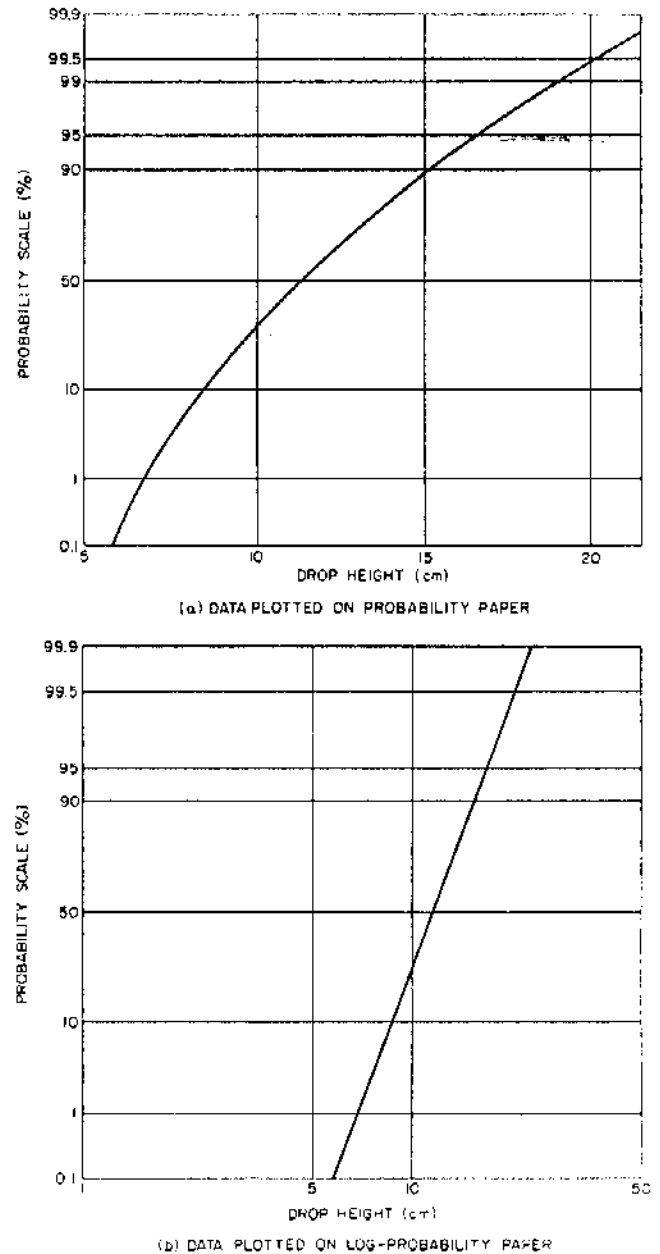

Figure 85. Skewed Frequency Distribution Typical of Impact Sensitivity Data



lot which would have fired or the only two which would have failed were those used in the test. Thus, the only statement which can be made with absolute certainty (100 percent confidence level) is that somewhere between 2.3 percent and 99.8 percent of the lot fired at this level. To assess the effect of reliability of the initiator upon that of the system, the reliability must be quoted at a confidence level somewhere between the 50 percent level (which states that 92 percent, more or less) will fire and the 100 percent level, which gives limits so broad as to be useless. Statisticians generally settle for 95 percent confidence level (19/1 odds that the statement is correct).

*d. Reliability Determination from Mean and Deviation.* The standard statistical techniques used in the conduct and analysis of many sensitivity tests yield data expressed in terms of a mean and standard deviation. The mean is the point at which 50 percent explosions are observed or anticipated. The deviation(s) of the sensitivity of an individual charge is the difference between the magnitude of the initiating impulse which is just sufficient to initiate it and the mean for the population from which it is drawn. The standard deviation of the population is the root of the mean square of the deviations of the whole population.

Where the correct normalizing function and the true standard deviation of the sensitivity of a charge, as well as the magnitude of the initiating impulse to be expected in use, are known, safety or reliability calculations are quite simple. A graphical method, as shown in Figures 84 and 85, can be used but is not usually needed. It is only necessary to divide the difference between mean and anticipated operating condition to obtain the deviation in standard deviation units and interpolate on a table (see Table 40<sup>b</sup>) to find the reliability. For example, if it is known that the mean sensitivity of a stab initiator is four inches when dropping a two-ounce ball (in this example, eight inch-ounces) with a standard deviation of one inch (two inch-ounces) and if the expected firing impulse is at least seven inches (fourteen inch-ounces), the deviation of the expected firing impulse from the mean sensitivity is six inch-ounces. This is three standard deviations above the mean and the predicted reliability is 99.87 percent.

It is well to note that the statement of this example starts with the qualifying phrase *if it is known*. Many reported sensitivity data are obtained by the use of experimental and analytical tech-

niques whose validity rests upon that of a series of assumptions which may or may not apply to the situation under consideration. In some cases, careful investigations have been made to validate these assumptions. Usually not. The fact that the standard deviation is quoted in inch-ounces implies that the probability of firing is normally distributed with respect to the energy of impact. Suppose that the true distribution is normal with respect to the logarithm of the energy. The log of the mean sensitivity is 0.903 with a standard deviation of about 0.1 log units, while the log of the expected firing energy is 1.146, or 0.243 log units above the mean. The expected firing condition, assuming the log-normal distribution, is 2.43 standard deviations above the mean. Interpolating on Table 40, the predicted reliability is only 99.23 percent. This one change in assumptions changes the expected failure rate significantly. Further, it is not correct to assume that a fourteen inch-ounce energy obtained by dropping a seven-ounce ball two inches is equivalent to the above example.

TABLE 40. SAFETY AND RELIABILITY RELATED TO DEVIATIONS FROM THE MEAN

No. of Std. Deviations From Mean	Probability of Occurrence (%)	
	For Positive* Deviation	For Negative* Deviation
0.253	60	40
0.524	70	30
0.842	80	20
1.000	84.13	15.87
1.282	90.0	10.0
1.500	93.32	6.68
1.645	95.0	5.0
2.000	97.73	2.27
2.054	98.0	2.0
2.327	99.0	1.0
2.500	99.38	0.62
2.575	99.5	0.5
2.875	99.8	0.2
3.000	99.87	0.13
3.09	99.9	0.1
3.29	99.95	0.05
3.50	99.98	0.02
3.73	99.99	0.01
4.00	99.997	0.00317
5.00		$2.87 \times 10^{-5}$
6.00		$1.0 \times 10^{-7}$
7.00		$1.3 \times 10^{-10}$
8.00		$6.4 \times 10^{-14}$
9.00		$1.2 \times 10^{-17}$
10.00		$8.0 \times 10^{-22}$

\* Positive and negative are meant to imply deviations toward and away from more probable occurrence.

The determination of the statistical distribution function of the sensitivity of a given type of charge

to a given type of initiating impulse obviously requires the test firing of large numbers of charges, each under closely controlled conditions. For some relatively inexpensive and easily tested items, such programs have been carried out.

In view of the high costs of many items and the relatively low rate at which they can be tested, it is too much to hope that all aspects of the sensitivity of all types of charge will ever be characterized in this respect. Where the designer is faced with the necessity of predicting safety or reliability of an item for which the distribution function is not known, the most prudent approach is to assume the function which gives the most pessimistic prediction (in the case of the last mentioned example, the log-normal distribution).

#### 106. Statistical Test Methods

*a. General Considerations.* The sensitivity of an explosive charge is the magnitude of the minimum stimulus which will result in its initiation. Stimuli too weak to initiate charges can still alter them, sometimes quite obviously, at other times in ways which can only be detected in terms of changed sensitivity. Hence, subjecting each charge to gradually increasing stimuli until it fires is not a satisfactory means for determining sensitivity.

In recognition of this variability, a number of statistical plans have been devised for sensitivity studies. Some of these plans are designed to characterize the entire distribution, others to characterize it in terms of an assumed normal distribution, and still others to determine some point in the distribution which was felt to be of particular interest. Before these plans may be applied, sampling procedure and criteria of acceptance must be established.

It is a basic assumption regarding any test of a limited sample that the sample is representative of the population from which it is drawn. Unless some effort is made at randomization, this may not be the case. Many of the variables which affect sensitivity may vary progressively or periodically as production proceeds. Selection of a sample for test by any systematic means might conceivably produce a biased sample, one in which all items are more similar in some respect than is the whole batch or lot. A positive plan of randomization should be adopted, such as use of a table of random numbers.

While most explosive charges used in ordnance function with nearly their maximum vigor, some

vary appreciably in output as the vigor of initiation is varied. Even within groups of items for which output is usually independent of input, an occasional individual item, when initiated marginally, will explode with significantly less than its maximum vigor. For these reasons, it is necessary to prescribe in advance the criterion of fire. Both the quantity associated with output and its magnitude should be specified. A shift of criterion part way through a test reduces the data to uselessness. Sometimes such shifts are inadvertent. For example, when plate dent output is used as a criterion, the supply of plates may be exhausted before completion. The replenished supply may come from a different heat of metal with a different response in terms of dent it sustains.

The criterion of fire will generally depend upon the purpose of the test. If it is a reliability test, the charge should be considered to have fired only if it detonated high order in the sense that its output cannot be distinguished from the maximum of which a charge of its type is capable (due allowance having been made for statistical fluctuations in this quantity). For safety tests, on the other hand, any evidence of burning, scorching, or melting of the explosive should be considered to be the criterion of fire.

*b. Staircase Method, The Bruceton Test.* A staircase testing technique is one in which a predetermined set of steps in the magnitude of the initiating stimulus is established before starting and in which the magnitude used for each trial is determined by results of previous trials. A number of staircase techniques have been proposed. Of these, the simplest and most used is the Bruceton test.<sup>7</sup> In the Bruceton test, the magnitude of stimulus used in each trial is determined by the result obtained in the immediately preceding trial. If the preceding trial resulted in a misfire, the stimulus to be used in the present trial is one step higher than that in the previous trial. If it fired, the stimulus of the present trial should be of a magnitude one step lower. The test is continued in this manner for a predetermined number of trials.

The validity of the results of this procedure depends on whether the assumption is valid that the steps are of uniform size in a system in which the frequency of explosions is normally distributed. The Bruceton test is most applicable to systems for which extensive tests have established the nature of a generic normalizing function. Unfortunately, it is often applied to systems for which it is not

economically feasible to carry on such a program. The logarithm of the initiating stimulus has frequently been assumed as a normalizing function (giving a geometric progression of step sizes) on the logical basis that this distribution predicts zero probability of functioning at zero input and that a positive stimulus is required for any finite probability of firing. This choice has been supported by such observations as the relative constancy of standard deviations of similar systems over large ranges of sensitivity. In some cases, rundown tests have also supported this choice.

It should be noted that the analytical technique for Bruceton data was originally devised with much larger tests in mind (100 shots or more) than those which have been used in most safety and reliability investigations. It seems to have been grasped as a straw by evaluators drowning in the impossible problem of predicting reliabilities to the 99.9+ percent level from samples as small as twenty-five samples. It is probable that those who have so little appreciation of the impossibility as to assign such a problem will accept solutions which depend on so many untenable assumptions.

The Bruceton experimental technique is often used as a convenient means for the collection of data in situations where the assumption of normality is known to be false and where it is intended to use other methods of analysis. An objection which has been raised to this practice is that the strong tendency of the Bruceton technique to concentrate testing near the 50 percent point reduces the value of the data in estimating the nature and deviation of the distribution. In answer, it may be pointed out that the sample sizes available when this technique is used are usually so small that a reasonable estimate of the mean and a rough guess of the deviation is the most which can be expected.

*c. The Frankford Run-Down Method.* A run-down method has been developed at Frankford Arsenal, which, at the expenditure of a much larger sample, makes possible a much better assessment of the distribution of the underlying population.<sup>8</sup> Beginning at any convenient level of the independent variable (drop height, voltage, barrier thickness, or the like) between 0% and 100% of the expected functioning level, a minimum of 25 trials is made at each of several levels above and below the starting level, using increments equal to or less than the expected standard deviation. The test is continued in both directions in this manner until the 0% and 100% functioning levels are reached as indicated

by 0% and 100% functioning in 25 consecutive trials. A cumulative probability plot is then drawn from the results of the test which is considered to be the frequency distribution of the parent population.

*d. Probit, Normit, and Logit Procedures.* These procedures are not data collecting schemes but rather analytical procedures for the estimation of distribution. They can utilize data collected by any of a number of schemes. They may be used with data collected by the Bruceton experimental technique using nonuniform steps or with incomplete or abbreviated versions of the run-down method.

Each of these procedures is based upon the transformation of the observed frequency of fire or misfire into a number related to the deviation in terms of an assumed distribution function. In the probit, for example, the mean is assigned a probit value of five, the 15.87 percent level (the mean minus one standard deviation) a value of four, the 84.13 percent point a value of six, and so forth.<sup>9</sup>

The normit differs from the probit procedure only in that a value of zero is assigned to the mean. This necessitates the use of negative values but frequently simplifies both thinking and arithmetic.

The logit system is similar but assumes the logit distribution function.<sup>10</sup> In addition to fitting certain data better than the normal curve, this function has the advantages of being somewhat more conservative in its predictions and of being simple enough to apply without special tables.

## B. TESTING TECHNIQUES

### 107. Explosive Materials

*a. General.* Explosive compounds or mixtures are evaluated for acceptance as standard materials on the basis of programs in which their explosive properties are determined. Many tests have been standardized to describe these explosive properties. In addition, special tests have been developed to take care of unusual conditions or to simulate a particular use.

This paragraph describes the purpose, nature, and key features of the tests on explosive materials. For a detailed discussion of the tests, the explosive charge designer should consult one of the handbooks on explosives.<sup>11\*</sup> The tests covered here are included partly for general information and partly because some of the tests have been applied to explosive charges. It is important to realize, however, that the performance of a loose explosive

sample may differ greatly from that of the same explosive when pressed into a cup so as to form an explosive component.

Tests of explosive materials are conveniently placed into four groups. Descriptions of tests pertaining to sensitivity, output, and stability follow. The fourth group is made up of chemical tests designed primarily to verify composition and state of aggregation. As such, these tests are not included in this volume but can be found in handbooks on explosives.<sup>11-14</sup> Included in this group are tests on flammability, hygroscopicity, volatility, molecular weight and oxygen balance.

*b. Sensitivity.* The tests grouped under sensitivity measure how easily explosive materials are initiated. They simulate the various stimuli which are capable of setting off the explosive. The stimulus used most widely is that of impact sensitivity. In addition to the following tests, the sand bomb test, listed under brisance output, is also a measure of sensitivity to initiation.

*(1) Impact Test.* The impact test consists of dropping a weight on a sample of explosive. The two most prevalent impact tests are those by Picatinny Arsenal (PA) and by the Bureau of Mines (BM). The PA apparatus is shown in Figure 86.

In the test, a sample of explosive is subjected to the action of a falling weight, usually 2 kilograms. A 20-milligram sample is always used in the BM apparatus while the PA sample weight is stated for each case. The minimum height at which at least one of 10 trials results in explosion is the impact test value. For the PA apparatus, the unit of height is the inch; for the BM apparatus, it is the centimeter.

In the PA apparatus, the sample is placed in the depression of a small steel die cup, capped by a thin brass cover in the center of which is placed a slot-vented cylindrical steel plug, slotted side down. In the BM apparatus, the explosive is held between two flat and parallel hardened steel surfaces. In the former the impact is transmitted to the sample by the vented plug, in the latter case by the upper flat plate. The main differences between the two tests are that the PA test (a) involves greater confinement (b), distributes the translational impulse over a smaller area, and (c) involves a frictional component. Hence, PA test values are greatly affected by sample density.

Some additional impact tests differ primarily in the construction of the sample holder. The tests have also been modified to accommodate cast and liquid explosives.

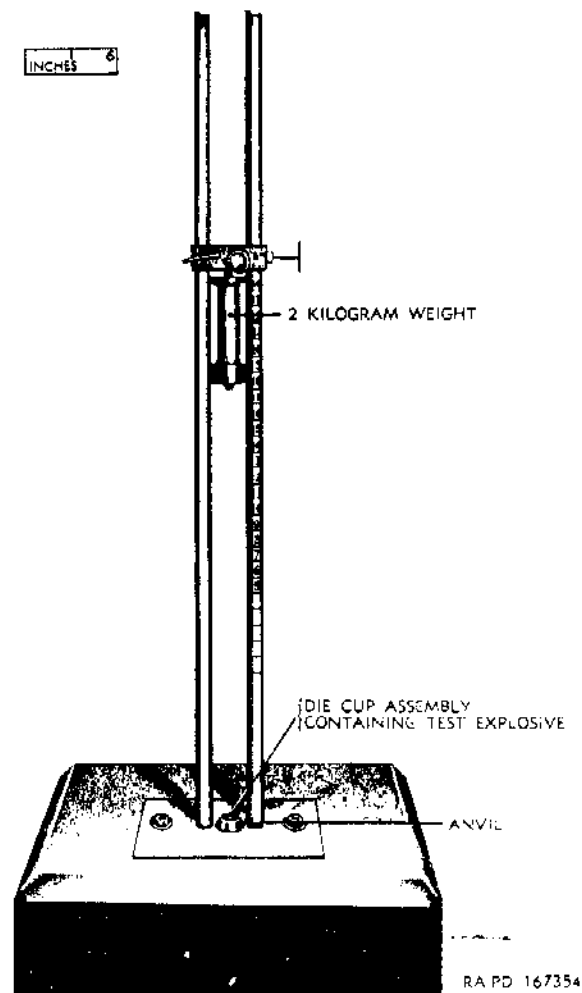

Figure 86. Picatinny Arsenal Impact Test Apparatus

*(2) Friction Pendulum Test.* To measure the sensitivity to friction, a 7 gm sample, 50-100 mesh, is exposed to the action of a steel or fiber shoe swinging as a pendulum at the end of a long steel rod. The behavior of the sample is described qualitatively to indicate its reaction to this experience, that is, the most energetic reaction is explosion and, in decreasing order of severity, snaps, cracks, and unaffected.

*(3) Rifle Bullet Impact Test.* The traditional bullet sensitivity test consists of firing a caliber 30 rifle into the side of a 3-inch pipe nipple, loaded with approximately 0.5-pound of the explosive being tested, and capped at both ends. Because of the curved surface presented as a target, the angle of incidence, and consequently the test results, can be greatly affected by the condition of the weapon and characteristics of the ammunition. An improved test with a flat target plate was devised at Picatinny Arsenal.<sup>11</sup>

(4) *Explosion Temperature Test.* A 20-milligram sample of secondary explosive or a 10-milligram sample of primary explosive, loose loaded in a No. 8 blasting cap cup, is immersed in a Wood's metal bath. The temperature determined is that which produces explosion, ignition, or decomposition of the sample in 5 seconds.

(5) *Booster Sensitivity Test.* The sensitivity of explosives to initiation by a booster is characterized in terms of the thickness of a wax barrier which, when placed between a cylindrical booster,  $1\frac{5}{8}$  inches by 2 inches, and the explosive being tested, will result in high order detonation of 50 percent of specimens. The set-up is shown schematically in Figure 87.

(6) *Setback Pressure Test.* To simulate the conditions experienced by the filler of a projectile during acceleration in a gun, the apparatus shown in Figure 88 was developed. By the action of the propellant, a pressure pulse is transmitted to an explosive specimen through the piston system which closely resembles these conditions. The criterion for each explosive tested is the maximum pressure at which the explosive cannot be initiated, when at an initial temperature of 125°F in 25 or more trials.

(7) *Armor Plate Test.* A modified 60mm M49A2 mortar projectile is loaded with the explosive to be tested. The loaded projectile, with fins attached, is fired against armor plate from a five-foot length of steel tubing by a bazooka igniter and a quantity of shotgun propellant sufficient to give the desired

velocity. The velocities are measured electronically, and the reaction is determined by observation (for example, whether or not flash occurs on impact). The minimum velocity required to produce an explosion is recorded.

(8) *Bomb Drop Test.* Bomb drops are usually made with bombs assembled in the conventional manner, but containing either inert or simulated fuzes. The target is usually reinforced concrete.

(9) *Cook-Off Temperature Test.* The temperature at which an explosive charge will explode is related to the size of the charge, its confinement, and the length of time it is heated, as well as the composition and loading density of the explosive. Cook-off is usually measured by inserting a projectile containing the test explosive into a carefully controlled oven. Temperature is measured by thermocouples inserted into the projectile. Rate of heating, location of thermocouple, and simulation of heat transfer to other charges and weapon parts all affect the cook-off temperature so that results vary with different apparatus. For high-rate-of-fire weapons in the small arms group, cook-off is best determined by heating the weapon in actual burst firing and then inserting an instrumented round into the chamber.<sup>12</sup> The cook-off temperatures quoted are threshold temperatures, those below which cook-off will not occur in an infinite time (practically, an hour).

(10) *Electrostatic Discharge Test.* To determine the sensitivity to electrostatic discharge, a 50 milligram sample of the explosive is placed on a flat metal electrode. A sharp metal electrode, which is connected to the first through a condenser charged to 5000 volts, is brought gradually closer to the flat electrode until the condenser discharges. By varying the electrical capacity, the energy of the discharge may be varied. Values quoted are maximum energies in joules for zero probability of initiation. These data may be related to hazards by keeping in mind that the human body, on a dry winter day, may store as much as 0.05 joules of static electrical energy.

*c. Output.* The tests grouped under output measure the effect that an explosive produces. As do the sensitivity tests, output tests measure a particular result which is judged to simulate performance.

(1) *Detonation Velocity.* Of the fundamental quantities associated with detonation, the propagation velocity is the most readily and directly measurable. While it is not a complete characterization of the output properties of an explosive, it is a good criterion of performance in many applications.

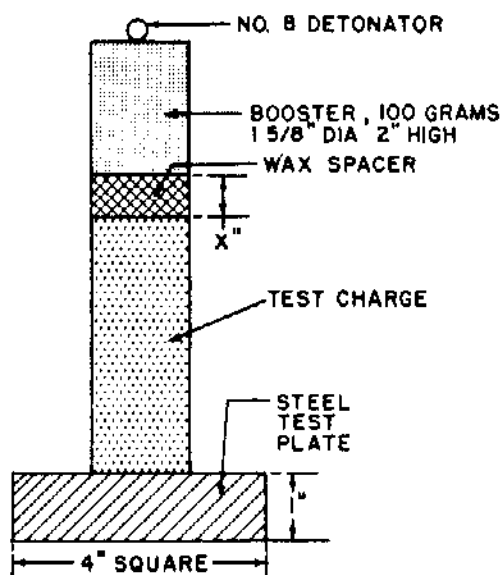

Figure 87. *Booster Sensitivity Test (Wax Gap)*

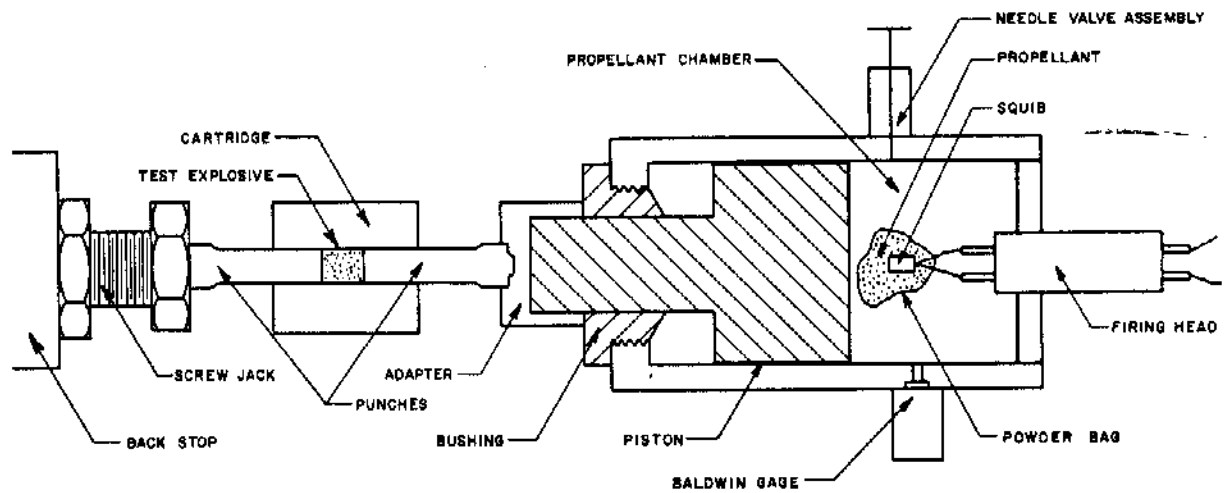

Figure 88. Apparatus Which Simulates Setback Pressure

Since the detonation velocity varies with both density and charge dimensions, results must be accompanied by accurate data regarding these quantities. Detonation velocity may be measured by optical techniques, by electrical measurements of transit time between points and by comparison with the known velocity of detonating cord.

The optical technique involves the use of a high speed camera. Streak cameras which have been used in detonation velocity measurements include rotating mirror cameras, rotating drum cameras, high-speed roll film cameras, and electronic image converter tube cameras.<sup>13</sup> Figure 11 is a record obtained by a streak camera. A high speed framing camera has also been developed which will take full image pictures at rates higher than four million frames per second.

The material within a detonation zone is highly ionized and, hence, an excellent electrical conductor. Thus a pair of electrical probes, placed in or close to an explosive charge, become electrically connected when a detonation, or the shock emitted by a detonation, engulfs them. Time intervals between such signals are measured with oscilloscopes and any of several types of interval timers.<sup>14,15</sup>

The d'Aurriche method (Fig. 89), depends upon the augmentation of radial output at the point where two waves in a cylindrical charge converge. Although it is attractive in that it requires no high cost instrumentation and has the reliability inherent in its extreme simplicity, this technique has fallen into disuse in recent years because of the higher precision obtainable with optical and electronic methods. With advent of mild detonating fuse,

whose small size makes precision location of the critical points of Figure 89 possible, and the development of precise means of detonation velocity control, new applications of the d'Aurriche method may be anticipated.

(2) *Detonation Pressure.* Detonation pressures are too high to measure directly with any ordinary pressure gages. The pressures of shocks induced by detonations in metals may be determined from measurements of the movement of the metal and of shock velocity in the metal. From such data and the laws of shock interaction, it is possible to deduce detonation pressure.<sup>13</sup> Detonation pressure may also be determined from detonation velocity and the density within the detonation zone, which may be measured by means of flash X-rays.

(3) *Brisance.* The shattering power of an explosive, as distinguished from its total work capacity, is termed brisance. Brisance is measured in sand, plate dent or fragmentation tests.

In the sand test, a 0.4-gm sample of the explosive under test pressed at 3000 psi into a No. 6 cap, is initiated by lead azide in a sand test bomb containing 200 gm of "on 30 mesh" Ottawa sand. The sand is resieved and is considered to have been crushed if it passes a No. 30 sieve. The significance of the sand test is difficult to state in physical terms. However, it does correlate, generally, with overall performance characteristics.

Plate dent tests, as used in brisance measurements, are made with charges long enough compared with their diameters that the detonation head can reach a stable configuration. The standard specimen is 1 $\frac{5}{8}$  inches diameter by 5 inches long. The depth of dent produced in the steel plate is

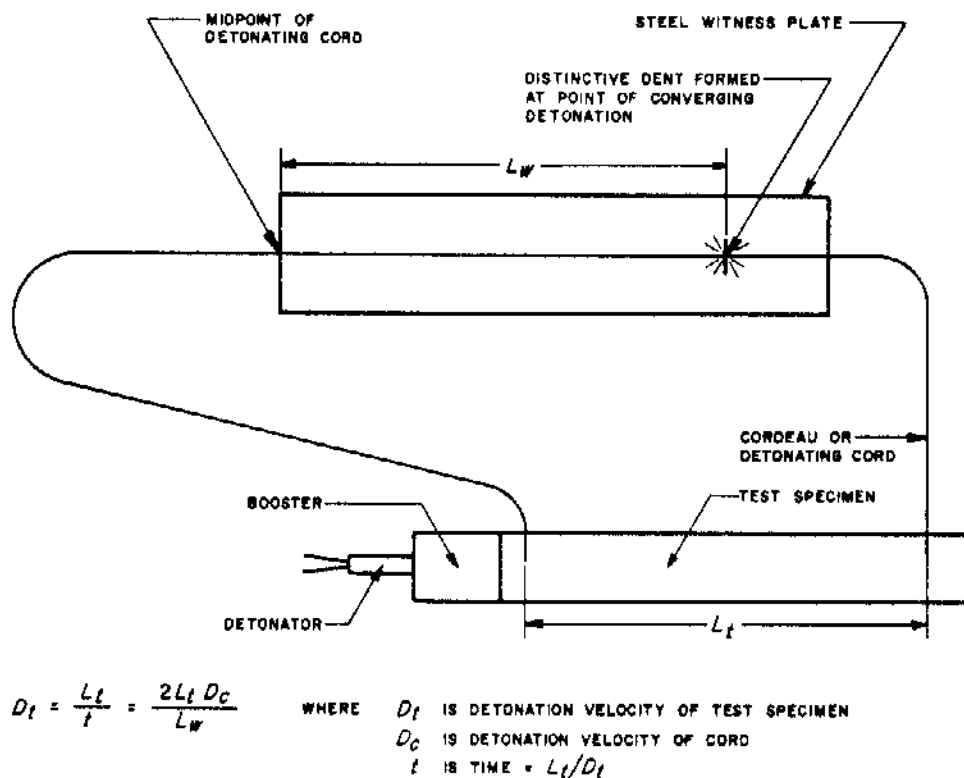

Figure 89. Method of d'Auriche for the Measurement of Detonation Velocity

compared with that produced by TNT. Plate dent brisance for bare charges correlated rather well with detonation pressure.

The fragmentation test is the most direct measure of the brisance of explosives. It consists of loading a projectile with the sample explosive, detonating the charge and recovering the fragments. The projectile is placed in a wooden box that is buried in sand and fired electrically. Recovery of fragments and their classification into weight groups permits evaluation of the charge.

(4) *Blast*. Blast pressures and impulses are determined almost exclusively with piezoelectric gages and the necessary specialized electrical circuits. Results are obtained by an analysis of oscillograms.

(5) *Ballistic Mortar*. A number of tests compare the effectiveness of explosives as propellants.<sup>15</sup> In general, to preserve the mortars used, the charges are relatively quite small (for example, ten grams in a ten-inch bore mortar). The quantity of the explosive being tested which gives the same recoil as ten grams of TNT is used as the basis for expressing the relative output of the explosive. Although ballistic mortar test data tend to correlate with usable output for many explosives, there are enough inversions to inspire serious questioning of the

meaning and validity of this type of data. Ballistic mortars have not been used extensively in recent years.

(6) *Trauzl Test*. In a Trauzl block test, a sample of explosive (on the order of 10 gm) is exploded in a cavity in a lead block. The increase in volume of the hole is the criterion of output. It is usually related to TNT. The Trauzl test is a direct measure of the mechanical work performed by the explosive. It tends to correlate with the heat of explosion, although the small sample size is rather small for complete reaction of TNT. More sensitive materials, which react more completely, tend to have larger Trauzl block values than might be expected.

*d. Stability*. The vacuum stability test is the most widely used stability test for explosives. A 5-gm sample (1 gm in the case of primary high explosives), after having been thoroughly dried, is heated for 40 hours in vacuum at the desired temperature (100° or 120°C). Temperatures and the volume of gas evolved (in cc) are quoted.

Other tests are the heat tests in which samples are heated for 48 hours and the effects noted. Actually, stability of explosives under conditions of service is too complex to be characterized com-

pletely on the basis of standardized laboratory tests. Tests like that for cook-off, which are tailored to simulate conditions of use, are often necessary.

### 108. Input

*a. Mechanical Initiators.* Most mechanical sensitivity tests, whether for stab or percussion items, consist of dropping weights from various heights. The most common means to this end is to release a weight from a magnet. The weights used in the testing of stab and percussion initiators are usually steel balls which are dropped free from the points of conical magnets. Impact machines include convenient means of adjusting the height of the magnet between drops and means for rapid and precise determination of the free fall distance (Fig. 86). In some machines, the height adjustment includes indexing stops for even intervals of height (usually fractions of an inch or centimeter). In others a dial, counter or scale is provided for rapid reading of the drop height. The latter have the advantage, in Bruceton type testing, that the step intervals may be varied to suit the appropriate normalizing function.

The drop test is performed in a manner similar to that used for explosive materials (Paragraph 107). A given weight (perhaps 2 ounces) is dropped from various heights on the firing pin and the results noted. Height steps are varied by the Bruceton technique (Paragraph 106).

*b. Electric Initiator.* Depending upon the application, the sensitivity of electric initiators should be characterized in terms of the threshold current, voltage, power, energy or some combination of these. A specification in terms of only one of them may be misleading. However, in many applications, one or another of these quantities is so much more

significant than the others that it is appropriate to characterize the sensitivity of the initiator in its terms. The sensitivity response can be defined more rigorously in most cases by controlling the time as well as the magnitude of the applied stimulus.

(1) *Condenser Discharge Test.* The sources used to fire electric initiators in many military applications emit pulses in which both current and voltage exceed, by many times, the threshold conditions for firing the initiator but for a very short duration. In many cases, the quantity which expresses limitation of output is the available energy. For this reason, it is a common practice to express the sensitivity of an electric initiator in terms of its energy requirement. The energy which is stored in a charged condenser is

$$W = 5 CE^2 \quad (38)$$

where  $W$  is the energy in ergs,  $C$  is the capacitance in microfarads, and  $E$  is the voltage. Theoretically, when a condenser is discharged through a resistance, all of the energy is dissipated as heat in the resistance. Thus a condenser discharge circuit is a means of dissipating an accurately known quantity of energy in an initiator, independent of variations in its resistance. The energy sensitivities of most of the electric initiators now in military use were determined by using circuits similar to that shown in Figure 90. Either voltage or capacitance may be varied to vary the energy. In many cases, convenience has been the basis for the choice. However, where a particular application is under consideration, the choice might be made on the basis of the limitations of the firing circuit in the fuze.

The threshold firing energy tends to vary inversely with the rate at which the energy is applied down to a point, characteristic of the initiator,

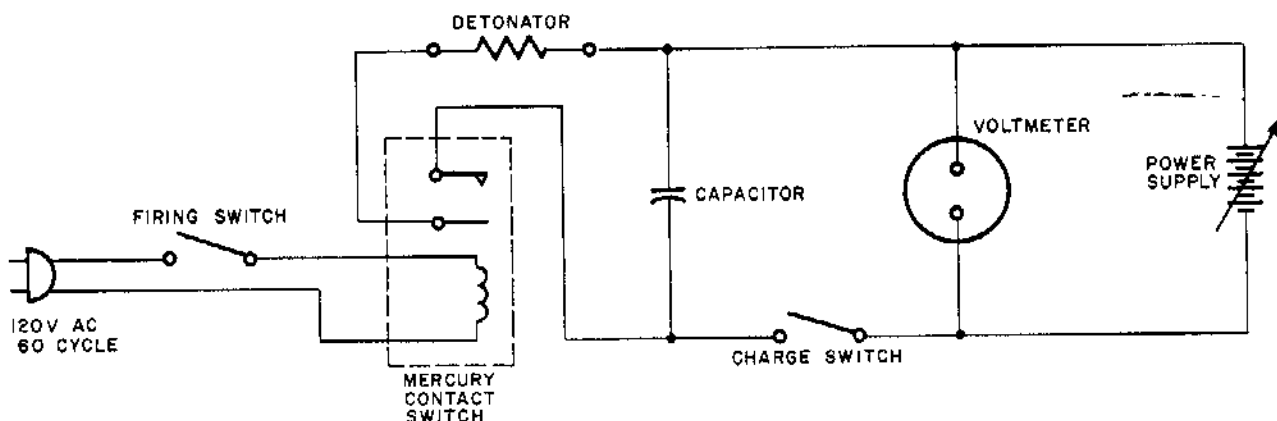

Figure 90. Typical Condenser Discharge Firing Circuit for Testing Electric Initiators



beyond which further increase in the rate of application has no effect on the energy required. Here is an important basic characteristic of an initiator. For general evaluation purposes, it is recommended that a condenser discharge circuit be chosen with a voltage high enough and a correspondingly small enough condenser that further change in the voltage will not affect the energy requirement of the detonator. An initiator test set has been developed which furnishes the proper signal and minimizes condenser and switch losses.<sup>6</sup>

(2) *Voltage Sensitivity.* Where the firing circuit is a very low voltage source, the impedance of which is low compared with that of the initiator, as for example, some types of battery, the threshold voltage for firing may be the most important criterion of sensitivity. Test firing circuits for the determination of threshold firing voltage should be, similarly, very low impedance circuits. A type of variable source which has proven useful in this respect is a high capacity storage battery shunted by a relatively low resistance potentiometer. The resistance of the potentiometer should be low compared with that of the initiator but not so low as to overtax the battery. Aside from this, the circuit should provide for switching and connecting with a minimum of resistance. Contact potentials and inductive surges have been misleading in such circuits. As for condenser discharge, a test set is also available for both constant voltage and constant current tests.<sup>16</sup>

(3) *Steady Current Functioning.* Where the firing source is of high impedance and limited current capacity, such as the high voltage supply of an electronic device, the firing current may be the most significant aspect of the sensitivity of an electric initiator. A test circuit for the determination of threshold firing current of an electric initiator should have an impedance which is high compared with the maximum resistance of the initiator during firing. A high voltage supply with a dropping resistor (a ratio of 10 to 1 is desirable) meets these requirements. The current may be varied from trial to trial by varying either the voltage or the resistance. In such circuits, if the switch is in series with the dropping resistance and the initiator in the wrong order, the distributed capacitance of the circuit can get charged to the supply voltage and discharged with an initial surge sufficient to fire the initiator. One means of insuring against such spurious effects is that of shunting the initiator with a switch which is opened to fire the initiator. Constant current pentode circuits have much higher effective impedances than can be realized by

circuits of the kind described. However, the current requirements of most electric initiators exceed the capacity of receiving pentodes.

c. *Gaps and Barriers.* The relative sensitivity of various explosives to initiation by detonation of nearby charges can be determined from the results of trials with varying gaps or barriers interposed.<sup>16-18</sup> In such evaluations, determinations are made of the mean and deviation of the gap or barrier using data collection schemes and statistical procedures similar to those described in Paragraph 106. The result is a threshold value of gap or barrier which will result in detonation.

It must be remembered, however, that the use of gap or barrier tests to evaluate the reliability of systems in which gaps or barriers are not part of the intended design is dubious at best. As pointed out in Paragraphs 27 and 68, gaps and barriers, particularly when combined, may actually improve a system. For example, it is possible to adopt a design on the strength of tests indicating a threshold gap of, say, a half inch and then find a forty percent failure rate in pilot lot tests with zero gap. Another possible pitfall in the use of gap and barrier tests for reliability predictions is the assumption of normality of the distribution of transmission probability with respect to the gap length, barrier thickness, or some function of these quantities. In one instance, a nonnormalizable distribution has been found.<sup>19</sup> Further, in complex systems, where gaps and barriers are combined with angular and axial displacements of consecutive charges, it is difficult to design gap, barrier, or transverse displacement tests from which predictions may be made, with reasonable confidence, of the reliability of transmission of detonation.

For these reasons, the Varicomp technique has been devised.<sup>20</sup> In this technique, construction, materials, and spatial configuration of a system under investigation are as nearly identical with those of the intended design as it is practical to make them. The probability of transmission between two consecutive components is reduced by the substitution of a less sensitive material in the acceptor element in the transfer under investigation. By the use of a series of explosives of graded sensitivity, using the sensitivity or composition as the independent variable in a data gathering system like the Bruceton technique, data may be obtained from which it is possible to determine the sensitivity or composition for 50 percent functioning and its standard deviation. These quantities may be

used in extrapolating to the material to be used (see Paragraph 106).

Explosives of varying sensitivity have also been used to estimate the reliability with which main charges may be expected to be initiated by means of boosters. For such purposes, the wax gap booster test has been used (see Paragraph 107).

### 109. Output

*a. Detonation.* The output of detonators, leads and boosters consists of a shock wave and high velocity hot particles. A number of indirect output tests are in use which are designed to give a quantitative measure of the ability of the test component to propagate the detonation in the next component. In addition to the tests listed, gaps and barrier tests (Paragraph 108) may be used for this purpose.

(1) *Sand Test.* The sand test, in which the output is characterized in terms of the amount of sand which is crushed by a detonator, gives a quantitative result for each trial. Early investigators<sup>21</sup> found good correlation between sand test results for blasting caps and their effectiveness in initiating dynamite. More recently, it has been found that detonators which give good sand test results may fail to initiate booster charges. The trend is away from sand tests for evaluation of explosive components.

(2) *Lead Disk Test.* This test consists of firing a detonator in direct end-on contact with a lead disk, in accordance with MIL-STD-317 (see Paragraph 110). The size of the hole produced in the disk is a measure of the output. Hole sizes are measured by means of taper gages or by photometric measurement of the amount of light from a standard source which passes through. In general, the lead disk test is a reasonably useful quality control test which correlates with the effectiveness of detonators. Significance in terms of physical quantities is difficult to assess. At least one situation has been experienced in which modifications in loading procedure which increased output according to the lead disk test decreased effectiveness in initiating subsequent charges.

(3) *Steel Dent Test.* The steel dent test consists of firing a detonator in direct end-on contact with a steel block in accordance with MIL-STD-316 (see Paragraph 110). The depth of the dent produced is a measure of output. The depth, or better the volume, of the dent correlates well with initiating effectiveness. The low rate detonation, which crushes nearly as much sand as high order detonation, makes no dent whatever in a steel plate. It has

been shown that the depth of dent is proportional to the excess of pressure over the yield strength of the steel of the dent block, integrated over the volume of the detonation head.

It has been found that a detonator of 0.190-inch diameter or larger, which produces a dent 0.010-inch deep in a mild steel block will initiate a lead of tetryl or RDX under favorable conditions.<sup>17</sup> Specification requirements for detonators to be used in fuzes are usually at least 0.015 to 0.020-inch depth and many produce dents up to 0.060-inch deep.

Dents tests are also used to measure the output of leads and boosters and to determine whether token main charges have been caused to detonate high order. Plates used for this purpose are sometimes referred to as witness plates.

(4) *Hopkinson Bar Test.* In this test, the output of a detonator is characterized in terms of the velocity imparted to a steel time piece which is in intimate contact with one end of a steel bar when the detonator is fired at the other end (see Fig. 91). The velocity of the time piece is a measure of the average pressure over the time it takes for the shock to traverse its length and the tension wave to return. For steel, this time in microseconds is almost exactly equal, numerically, to the length of the time piece in centimeters (since both shock and tension waves propagate at 0.5 cm/microsec).

Although the velocity of the time piece is a precise and rigorous measure of the momentum of the shock in the bar, the relationship between this shock and the output of the explosive charge which induced it is less clear. The coupling between the output of the detonator and the input end of the bar is necessarily quite poor. Direct exposure of

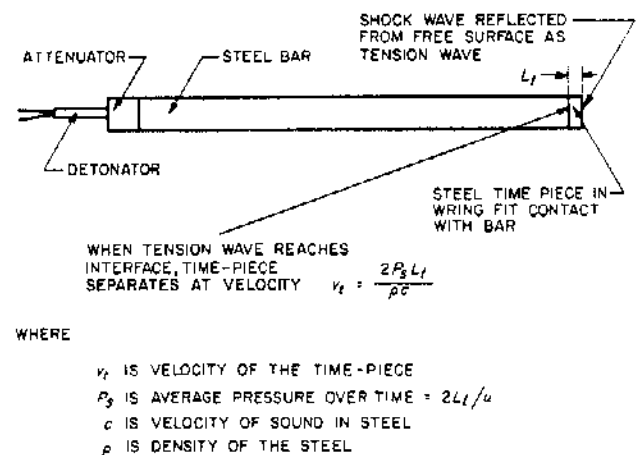

Figure 91. Principle of Hopkinson Bar Measurement of Detonator Output

the bar to the action of the detonator results in damage with each shot and progressively changing characteristics. The effect of attenuators (to protect the bar) on output has not been established. Hence, the test is only in experimental use.

(5) *Velocity of the Air Shock.* Since the velocity of an air shock is a direct measure of its strength, measurements of air shock velocity may seem to be attractive means of measuring detonator output. However, at the short range over which the blast output of a detonator is effective, a larger part of the effectiveness is attributable to the kinetic energy of the reaction products which support the shock than to the shock itself. In this respect, an inversion results from the nonideality of the reaction product gases. Hence, velocity of the air shock is not a suitable output measure.

(6) *Detonation Pressure Measured by Means of Shock Transducers.* The output of detonators may be determined by measuring detonation pressure waves.<sup>22</sup> Two types of solid state transducers are used to record the intense stress waves involved. One, based upon changes in electrical conductivity of materials normally considered as insulators, provides not only a reading of the peak intensity of the wave but also a record of pressure variation with time. The second transducer utilizes the polarization of molecular solids to provide a device more capable of resolving the very steep shock fronts often produced by explosives of high brisance.

The explosive item to be tested is placed with its output end on the transducer and initiated in the normal manner. When the detonation wave passes through the transducer, a signal proportional to the magnitude of the pressure is produced which is recorded on an oscilloscope or other electronic device thus indicating the output of the explosive.

*b. Nondetonating Items.* The output of nondetonating explosive charges requires entirely different measuring techniques from those of detonating charges. On the one hand, detonating output is more difficult to measure but on the other hand more work has been done with detonators and more tests have been standardized. Nondetonating output includes flames of deflagrating charges (primers, squibs, delay columns) and mechanical output (explosive actuators).

(1) *Flame Output.* The most prevalently used instrument for the testing of primer output is a manometer connected to a closed chamber into which the primer fires. The output pulse of the primer imparts momentum to the liquid in the

manometer, causing it to displace to a maximum and recede. The maximum displacement is proportional to the momentum and is referred to as the impulse of the primer. The volume of gas emitted, may, of course, be measured after the manometer reaches equilibrium.

A thermocouple placed in the flame gives some measure of temperature although the question may be raised as to whether it ever reaches equilibrium. Perhaps, in many applications, the temperature reached by such a thermocouple, which is proportional to the quantity of heat transferred to a solid by the flame, is more pertinent than the actual flame temperature.

Light output, as measured by a photocell, has also been used as a measure of primer output. If the light is mainly black body radiation, it may be quite significant. However, the presence of some elements, such as sodium, which have strong spectral output, might bias such results unduly.

The lead disk test, employed for detonating output, has been used for primers. Primer output does not puncture the disk; rather the volume of the dent becomes the measure of output. Softer materials, such as styrofoam, have also been used experimentally for this purpose to achieve a larger volume.

A test set has been developed to measure the output of flame producing charges by measuring flame temperature and length.<sup>23</sup>

(2) *Mechanical Output.* The series of mechanical actuators includes diaphragm motors, bellows motors, piston motors and switches. The output of these devices is usually specified in terms of pushing a given weight through a given distance. Use of a test fixture employing dead weights is therefore best.

Output tests have often been performed by having the actuator push against a spring. Since the spring force is not constant, it is important to specify in this case whether the given force is measured at the start or end of the stroke. In the case of switches, it has been suggested that the initial hump in the load curve of a switch can be simulated by having a pin rupture a metal foil.

## 110. Environment

Explosive charges must not only perform as intended; they must also be safe and operable in the environment in which they are expected to perform. Encompassing deep water to outer space, the range of military environments is indeed formidable. A series of tests has been developed to

simulate the various conditions to which ammunition may be subjected.

Many of the tests have been standardized to assure uniform conditions. The bulk of the tests of interest to the explosive charge designer are grouped in the 300 series of the Military Standards pertaining to fuzes. These Standards are listed in Table 41 in two groups, those which apply during item development and those which determine quality in production. All of the standards are compiled in *Department of Defense Index of Specifications and Standards*, 30 July 1961, a consolidation of previous volumes issued by the three services. A convenient summary of descriptions and use of these tests has been compiled for fuze components.<sup>e</sup>

The explosive charge designer faces more severe testing problems than the fuze designer because of the relative smallness of his components in the system. For some of the components, the MIL-STD tests are frankly meaningless. There is no reason, for example, to subject a booster charge pellet to the jumble test. On the other hand, it is dangerous to introduce an untested component, particularly a new concept, into the military environment. In some instances, other system components may help (confinement, structural strength, sealing, cushioning), in other instances, they may hinder (incompatible materials, unplanned electric paths, stress concentrations). This problem must be resolved by sound engineering judgement. If, for example, detonators are to be subjected to a drop test, they can be placed within a jig which permits positioning and introduces confinement.<sup>24</sup>

The chief purpose of environmental tests is to insure safety during rough handling and surveillance. The safety tests are of two types, destructive and non-destructive. Operability is *not* required after destructive tests, such as Jolt (MIL-STD-300, MIL-STD-350) while operability is required after non-destructive tests such as Transportation Vibration (MIL-STD-303, MIL-STD-353). All surveillance tests are non-destructive, such as Temperature and Humidity (MIL-STD-304, MIL-STD-354).

It is important to understand that MIL-STD tests are never specified unless they serve a definite purpose. The selection of tests for application in a particular case requires engineering judgement. Tests must not be applied indiscriminately. On the other hand, once a standard test is prescribed, it is mandatory that it be performed precisely as specified without deviation. The 300 series of MIL-STD's includes a number of tests which apply to special

conditions only, such as Jettison Tests (MIL-STD's 307a to 310). For other conditions, additional tests

TABLE 41. MIL-STD TESTS FOR FUZES

<i>Development Series</i>	
MIL-STD-300	Jolt Test for Use in Development of Fuzes, 6 July 1951.
MIL-STD-301	Jumble Test for Use in Development of Fuzes, 6 July 1951.
MIL-STD-302	Forty (40) Foot Drop Test for Use in Development of Fuzes, 6 July 1951.
MIL-STD-303	Transportation Vibration Test for Use in Development of Fuzes, 6 July 1951.
MIL-STD-304	Temperature and Humidity Test for Use in Development of Fuzes, 6 July 1951.
MIL-STD-305	Vacuum-Steam-Pressure Test for Use in Development of Fuzes, 26 March 1952.
MIL-STD-306	Salt Spray (Fog) Test for Use in Development of Fuzes, 27 March 1952.
MIL-STD-307a	Jettison (Aircraft Safe Drop) Test for Use in the Development of Fuzes, 17 November 1958.
MIL-STD-308	Jettison (Simulated Aircraft Safe Firing, from Ground Launcher) Test for Use in the Development of Rocket-Type Fuzes, 4 August 1953.
MIL-STD-309	Jettison (Simulated Aircraft Safe Drop, from Ground Launcher) Test for Use in the Development of Fuzes, 5 August 1953.
MIL-STD-310	Jettison (Aircraft Safe Firing) Test for Use in the Development of Rocket-Type Fuzes, 5 August 1953.
MIL-STD-311	Accidental Release (Low Altitude, Hard Surface) Safety Test for Use in the Development of Fuzes, 4 August 1953.
MIL-STD-312	Muzzle Impact Safety Test for Use in Development of Projectile Fuzes, 15 January 1954.
MIL-STD-313	Impact-Safe Distance Test for Use in Development of Projectile Fuzes, 15 January 1954.
MIL-STD-314	Waterproofness Test for Use in Development of Fuzes, 20 September 1954.
MIL-STD-315	Static Detonator Safety Test for Use in Development of Fuzes, 29 November 1954.
MIL-STD-316	Detonator Output Measurement By the Steel Dent Test, 22 September 1961.
MIL-STD-317	Detonator Output Measurement by the Lead Disc Test, 17 December 1959.
MIL-STD-318	Missile Pull-Off From Aircraft on Arrested Landing (Ground Launcher Simulated) Safety Test for Use in Development of Fuzes, 6 February 1959.
MIL-STD-319	Time to Air Burst Test for Use in Development of Projectile Time Fuzes, 20 May 1959.
MIL-STD-320	Terminology, Dimensions, and Materials of Explosive Components, for Use in Fuzes, 3 August 1959.
MIL-STD-321	Jettison (Aircraft Safe Drop) Test for Use in the Development of Fuzing Systems, 1 September 1959.
<i>Production Series</i>	
MIL-STD-350	Jolt Test for Use in Production of Fuzes, 6 July 1951.
MIL-STD-351	Jumble Test for Use in Production of Fuzes, 6 July 1951.
MIL-STD-352	Forty (40) Foot Drop Test for Use in Production of Fuzes, 6 July 1951.
MIL-STD-353	Transportation Vibration Test for Use in Production of Fuzes, 6 July 1951.
MIL-STD-354	Temperature and Humidity Test for Use in Production of Fuzes, 26 November 1958.
MIL-STD-355	Vacuum-Steam-Pressure Test for Use in Production of Fuzes, 13 April 1953.
MIL-STD-356	Salt Spray (Fog) Test for Use in Production of Fuzes, 13 April 1953.
MIL-STD-358	Five Foot Drop Test for Use in Production of Fuzes, 17 November 1958.

may have to be performed, such as Sand and Dust (MIL-E-5272B).

Four tests in the MIL-STD-300 series apply specifically to explosive components. The Static Detonator Safety test (MIL-STD-315) determines whether the rest of the train will be set off when the detonator is initiated in the unarmed position. The fuze or test fixture must be modified so that the detonator may be initiated in the safe position. A typical modification is shown in Figure 92. The test is successful if no explosive charge beyond the arming device functions, chars or deforms.

Detonator output tests by lead disk (MIL-STD-317) and steel dent (MIL-STD-316) are discussed in Paragraph 109. Terminology, Dimensions, and Materials of Explosive Components (MIL-STD-320) applies to the selection of standard parts during the design phase. The application of this standard is discussed in Paragraph 53 and 73.

As in performance tests, programming is important in the environmental series. It may be desirable to combine several tests sequentially or to add tests to introduce such special conditions as acceleration which can be performed in air gun or

centrifuge. Sufficient samples must be tested to assure significant results. As a rule of thumb, no fewer than five samples should ever be tested. The quantity depends on the criteria for test acceptance, the destructive test (criterion: did this item explode?) requiring fewer samples than the non-destructive test (criterion: is performance affected?).

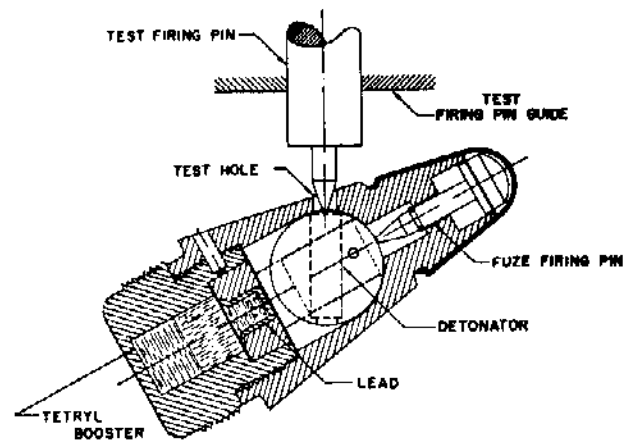

Figure 92. Arrangement for Detonator Safety Test

## REFERENCES

### CHAPTER 11

*a-i Lettered References are listed in Paragraph 12 (end of Chapter 1).*

1. Engineering Design Handbook 110, *Experimental Statistics, Section 1, Basic Concepts and Analysis of Measurement Data.*\*
2. Engineering Design Handbook 111, *Experimental Statistics, Section 2, Analysis of Enumerative and Classificatory Data.*\*
3. Engineering Design Handbook 112, *Experimental Statistics, Section 3, Planning and Analysis of Comparative Experiments.*\*
4. Engineering Design Handbook 113, *Experimental Statistics, Section 4, Special Topics.*\*
5. Engineering Design Handbook 114, *Experimental Statistics, Section 5, Tables.*\*
6. A. Hold, *Statistical Theory With Engineering Applications*, John Wiley & Sons, New York, 1952.
7. *Statistical Analysis for a New Procedure in Sensitivity Experiment*, AMP Report 101.1R SRG-P No. 40, Statistical Research Group, Princeton University, Princeton, N. J., July 1944 (ATI-34 558).
8. C. W. Churchman, *Statistical Manual, Methods of Making Experimental Inferences*, Pitman-Dunn Laboratories, Frankford Arsenal, 1951.
9. D. J. Finney, *Probit Analysis*, Cambridge University Press, 1947.
10. J. Berkson "A Statistically Precise and Relatively Simple Method of Estimating the Bio-Assay with Quantal Response", *J. Am. Statistical Assoc.*, 48, 263, 565-599 (1953).
11. S. D. Stein, *Quantitative Study of Parameters Affecting Bullet Sensitivity of Explosives*, Picatinny Arsenal Technical Report 2636, September 1959.
12. Gunther Cohn, *Cook-Off in Aircraft Guns*, The Franklin Institute, Report F-A2144-2, Contract DA-36-034-504-ORD-10RD, June 1960 (SPIA 20-668, AD-239 808).
13. *Second ONR Symposium on Detonation*, Office of Naval Research, Navy Dept., February 9-11, 1955, papers 15-17, pp. 209-264.
14. L. D. Hampton and R. H. Stresau, *Small Scale Technique for Measurement of Detonation Velocities*, Naval Ordnance Laboratory (White Oak), NAVORD Report 2282, 27 December 1951.
15. C. E. Munroe and J. E. Tiffany, *Physical Testing of Explosives at the Bureau of Mines Explosives Experiment Station*, Bruceton, Pa., Commerce Dept., Bureau of Mines, Bulletin 346, 1931.
16. *Proceedings of the Electric Initiator Symposium (U)*, held at The Franklin Institute September 11-12, 1957, papers XXIII and XXXIII (AD-153 579) (Confidential).
17. L. D. Hampton, W. M. Slie and R. H. Stresau, *Direct Initiators of Boosters by Electric Initiators (U)*, Naval Ordnance Laboratory (White Oak), NAVORD Report 2815, 13 March 1953 (Confidential).
18. W. M. Slie, *A Study of Output of Detonators Versus Internal Design Characteristics of Limited External Dimensions (U)*, Naval Ordnance Laboratory (White Oak), NAVORD Report 3593, 10 December 1953 (Confidential).
19. R. McGill and P. Holt, Eds., *Proceedings of the Gilbert B. L. Smith Memorial Conference on Explosive Sensitivity (U)*, Naval Ordnance Laboratory (White Oak), NAVORD Report 5746, 2 June 1958, p. XV-B-71 (Confidential).
20. J. N. Ayers et al., *Varicomp, A Method for Determining Detonation-Transfer Probabilities*, Naval Ordnance Laboratory (White Oak), NAVWEPS Report 7411, July 1961.
21. C. G. Storm and W. C. Cope, *The Sand Test for Determining the Strength of Detonators*, Bureau of Mines, Dept. of Interior, Technical Paper 125, 1916.
22. R. J. Eichelberger and G. E. Hauver "Solid State Transducers for Recording of Intense Pressure Pulses" *Les Ondes de Detonation*, Editions du Centre National de la Recherche Scientifique, Paris, 1962.
23. *Design and Development of Tests for Characterization of Initiators*, University of Denver, Denver Research Institute, Combined Final Report and Operation Manual, Contracts DAI-28-017-501-ORD(P)-1811, DAI-23-072-501-ORD(P)-37, December 1958.
24. R. E. Trezona and E. L. Miller, *Forty-Foot Drop Test for Detonators (U)*, Picatinny Arsenal, Explosives Development Section, Report 28, May 1958 (Confidential).

---

\* See inside back cover for handbook designation.

## GLOSSARY OF KEY TERMS

This Glossary is an excerpt from *Nomenclature and Definitions in the Ammunition Area*, MIL-STD-444, 6 February 1959. Definitions are often abbreviated and only terms pertaining to explosive charge design are included.

**actuator.** An explosive device that produces gas at high pressure in short periods of time into a confined volume for the purpose of doing work. Dimple motors, bellows motors and switches are examples of actuators.

**booster.** An assembly of metal parts and explosive charge provided to augment the explosive components of a fuze to cause detonation of the main explosive charge of the ammunition. It may be an integral part of the fuze. (This term is often used as an abbreviation for booster charge).

**booster charge** 1. The explosive charge contained in a booster. It must be sufficiently sensitive to be actuated by the small explosive elements in the fuze and powerful enough to cause detonation of the main explosive filling. 2. The amount or type of explosive used to reliably detonate the bursting charge of ammunition.

**brisance.** The ability of an explosive to shatter the medium which confines it; the shattering effect shown by an explosive.

**combustion.** The continuous rapid combination of a substance with various elements such as oxygen or chlorine or with various oxygen bearing compounds, accompanied by the generation of light and heat.

**cook-off.** The deflagration or detonation of ammunition by the absorption of heat from its environment. Usually it consists of the accidental and spontaneous discharge of, or explosion in, a gun or firearm caused by an overheated chamber or barrel igniting a fuze, propellant charge, or bursting charge.

**deflagration.** A very rapid combustion sometimes accompanied by flame, sparks, or spattering of burning particles. A deflagration, although classed as an explosion, generally implies the burning of a substance with self-contained oxygen so that the reaction zone advances into the unreacted ma-

terial at less than the velocity of sound in the unreacted material.

**delay.** An explosive train component that introduces a controlled time delay in the functioning process.

**detonation.** An exothermic chemical reaction that propagates with such rapidity that the rate of advance of the reaction zone into the unreacted material exceeds the velocity of sound in the unreacted material. The rate of advance of the reaction zone is termed detonation velocity. When this rate of advance attains such a value that it will continue without diminution through the unreacted material, it is termed the stable detonation velocity. When the detonation velocity is equal to or greater than the stable detonation velocity of the explosive, the reaction is termed a high order detonation. When it is lower, the reaction is termed a low order detonation.

**detonator.** An explosive train component which can be activated by either a nonexplosive impulse or the action of a primer and is capable of reliably initiating high order detonation in a subsequent high explosive component of train. When activated by a nonexplosive impulse, a detonator includes the function of a primer. In general detonators are classified in accordance with the method of initiation: such as percussion, stab, electric, flash, etc.

**explosion.** A chemical reaction or change of state which is effected in an exceedingly short time with the generation of a high temperature and generally a large quantity of gas. An explosion produces a shock wave in the surrounding medium. The term includes both detonation and deflagration.

**explosive.** A substance or mixture of substances which may be made to undergo a rapid chemical change, without an outside supply of oxygen, with the liberation of large quantities of energy

generally accompanied by the evolution of hot gases.

**explosive train.** A train of combustible and explosive elements arranged in an order of decreasing sensitivity. Its function is to accomplish the controlled augmentation of a small impulse into one of suitable energy to cause the main charge of the munition to function. It may consist of primer, detonator, delay, relay, lead, and booster charge, one or more of which may be either omitted or combined.

**firing pin.** An item in a firing mechanism of a fuze which strikes and detonates a sensitive explosive to initiate an explosive train.

**high explosive (HE).** An explosive which when used in its normal manner detonates rather than deflagrates or burns; that is, the rate of advance of the reaction zone into the unreacted material exceeds the velocity of sound in the unreacted material.

**igniter.** A device containing a specially arranged charge of a ready burning composition, usually black powder, used to amplify the initiation of a primer.

**initiator.** A device used as the first element of an explosive train, such as a detonator or squib, which upon receipt of the proper mechanical or electrical impulse produces a burning or detonating action. It generally contains a small quantity of a sensitive explosive.

**lead.** (Rhymes with "feed") An explosive train component which consists of a column of high explosive, usually small in diameter, used to transmit detonation from a detonator to booster charge.

**low explosive (LE).** An explosive which when used in its normal manner deflagrates or burns rather than detonates; that is, the rate of advance of the

reaction zone into the unreacted material is less than the velocity of sound in the unreacted material. Low explosives include propellants, certain primer mixtures, black powder and delay compositions.

**primary high explosive.** An explosive which is extremely sensitive to heat and shock and is normally used to initiate a secondary high explosive. A primary explosive is capable of building up from a deflagration to detonation in an extremely short distance and time; it can also propagate a detonation wave in an extremely small diameter column.

**primer.** A relatively small and sensitive initial explosive train component which on being actuated initiates functioning of the explosive train and will not reliably initiate high explosive charges. In general, primers are classified in accordance with the methods of initiation; such as percussion or stab.

**relay.** An explosive train component that provides the required explosive energy to cause the next element in the train to function reliably. It is especially applied to small charges that are initiated by a delay element and, in turn, cause the functioning of a detonator.

**secondary high explosive.** A high explosive which is relatively insensitive to heat and shock and is usually initiated by a primary high explosive. It requires a relatively long distance and time to build up from a deflagration to detonation and will not propagate in extremely small diameter columns. Secondary high explosives are used for boosters and bursting charges. Sometimes called 'non-initiating high explosives.'

**squib.** A small explosive device, similar in appearance to a detonator, but loaded with low explosive, so that its output is primarily heat (flash). Usually electrically initiated, it is provided to initiate action of pyrotechnic devices.



## INDEX

- Acceleration, 6, 58, 86
- Actuator, 105, 136
- Aerodynamic heating, 5, 53
- Ammunition, 100
- Arrhenius equation, 14
- Auxiliary booster, 103
- Availability, 118
  
- Ballistic mortar, 132
- Barrier, 40, 92, 134
- Bases for explosive charge selection, 3, 65, 87
- Bellows motor, 105, 136
- Blast, 42
- Boosted surround, 103
- Booster
  - charge, 89
  - construction, 98
  - design, 92
  - position, 103
  - sensitivity test, 36, 130
- Bridge wire, 25, 30, 51, 67, 78
- Brisance, 131
- Bruceton technique, 127
- Bullet impact test, 57
- Burning, 13, 16
  
- Carbon bridge, 26, 71, 78
- Casting, 109
- Cementing, 118
- Chapman-Jouguet condition, 21
- Characteristics, 120
- Chemical decomposition, 49
- Chemical interaction, 55, 120
- Compatibility, 56, 120
- Condenser discharge test, 133
- Conductive explosive mix electric initiator, 26, 72
- Conductive film electric initiator, 26, 71, 78
- Confinement, 38, 75, 87, 92, 103
- Construction. *See* specific explosive charge
- Cook-off, 48, 51, 130
- Cup, 75
  
- d'Autriche method, 131
- Deflagration, 13, 16
- Delay composition, 82
- Delay element, 80
- Demolition block, 107
- Demolition device, 106
- Density. *See* loading density
- Design considerations, 1, 9, 62, 92
  
- Destructor, 106
- Detonating cord, 107
- Detonation
  - pressure, 74, 120, 131
  - transfer to another charge, 33, 135
  - transition from deflagration, 17
  - velocity, 22, 120, 130
  - wave, 20, 41, 95
- Detonator
  - construction and fabrication, 75
  - design, 66
  - function, 62
  - output, 73, 135
- Dimensional interaction, 34
- Dimple motor, 105, 136
  
- Economics, 9
- Electric initiation, 25, 80
- Electric initiator, 63, 67, 77, 133. *See also* specific explosive charge
- Electric spark initiation, 30
- Electrical aspects, 9, 59, 130
- Environmental response, 48, 55, 136
- Equation of state, 20
- Evaluation procedure, 35, 57, 123
- Exploding bridge wire, 30, 70
- Explosion temperature, 15, 130
- Explosive
  - bolt, 108
    - Characteristics, 120
    - material, 71, 73, 90, 128
    - sheet and tube, 107
    - train, 1
- Explosive charge. *See also* specific explosive charge (actuator, booster, delay, detonator, lead, main bursting charge, primer, relay, squib)
  - bases for selection, 3, 65, 87
  - design considerations, 1, 9, 62, 92
  - fabrication, 109
  - general description, 1, 62, 80, 89, 100, 105
  - loading, 109
  - purpose, 1
  - system approach aspects, 4
- Exudation, 50
  
- Fabrication, 109. *See also* specific explosive charge
- Failure diameter, 93, 120
- Film bridge electric initiator, 26, 71, 78

- Finishing operation, 117
- Firing pin, 29, 66
- Flame output, 136
- Flash charge, 78
- Flash detonator, 63, 67, 77
- Fragmentation, 7, 44
- Frankford run-down method, 128
- Frequency distribution, 124
- Friction, 29, 59, 129
- Functioning, 7
- Fundamental principles, 1
  
- Gap test, 35
- Gap and barrier, 40, 92, 134
- Gasless delay compositions, 84
- Glossary, 140
- Graphite film bridge, 26, 71, 78
- Gurney constant, 44
  
- Heat initiation, 25
- Heat of explosion, 74, 120
- High temperature effect, 53
- Hopkinson bar test, 135
- Hot spot theory of initiation, 15
- Hot wire electric initiator, 25, 67
- Hugoniot curve, 20
  
- Ignition powder, 84
- Ignition temperature, 15
- Illustrations, list, vii
- Impact initiation, 28
- Impact simulation, 57, 129
- Information sources, 11
- Initiation
  - by heat, 25, 67
  - by impact, 28
  - by other means, 29
  - effectiveness, 33
  - general, 23, 33
  - sensitivity, 35, 49, 102
- Initiator. *See* specific explosive charge
- Input characteristics, 66, 133
- Irradiation, 59
  
- Lead
  - construction, 96
  - design, 92
  - function, 89
- Lead azide, 18, 121
- Lead disk test, 135, 138
- Lead styphnate, 18
- Lethality, fragment, 44
- Loading, 109. *See also* specific explosive charge
  
- Loading density, 27, 66, 75, 82, 86, 94, 113, 120, 121
- Low temperature effect, 54
  
- Machining, 117
- Main bursting charge, 100
- Mechanical aspects, 7
- Mechanical initiator. *See* specific explosive charge
- Melting, 53, 120
- Mild detonating fuse, 107
- Military environment, 48
- Military standard, 137
- Misaligned charge, 40
  
- Obturated delay, 80, 83
- Out-of-line safety, 3, 8
- Output, 41, 72, 95, 106, 119, 130, 135
  
- Pelletizing, 115
- Percussion initiation, 29, 66, 80
- Percussion primer, 63, 66, 77, 133
- Piston motor, 105, 136
- Plug for electric initiator, 77
- Pressing, 111, 121
- Primer
  - construction and fabrication, 75
  - design, 66
  - function, 62
  - output, 72, 136
- Priming composition, 66
- Projectile preparation, 109
  
- Quality control, 121
  
- Reaction kinetics, 13
- References, 12, 32, 47, 61, 79, 88, 99, 104, 108, 122, 139
- Relay, 82
- Reliability, 10, 123
- Resistivity of wire bridge, 68
- Ring delay, 81
  
- Safety, 3, 8, 10, 123
- Sand test, 135
- Sensitivity test, 26, 35, 119, 128
- Sensitivity to initiation, 26, 35, 49, 66, 102
- Sensitization, 54
- Setback acceleration, 6, 58, 130
- Shaped charge, 46
- Shock velocity, 35
- Shock wave, 19
- Simulation of impact, 57
- Spark gap electric initiator, 72, 78
- Spotting charge, 78

Spurious electrical signal, 9  
Squib, 63, 72  
Stab initiation, 29, 66  
Stab initiator, 63, 66, 77, 133  
Stagnation temperature, 5  
Standardization, 11  
Statistical test method, 123  
Steel dent test, 135, 138  
Structural aspects, 6  
Suitability, 118  
Switch, 105  
Symbols, list, x  
Systems approach to ammunition, 4  
  
Tables, list, ix  
Temperature effect, 49, 85  
Testing technique, 35, 57, 123, 128, 135

Thermal decomposition, 13  
Transfer of detonation from one charge to another,  
33, 135  
Transition from deflagration to detonation, 17  
Trauzl test, 132  
  
Underground output effect, 45  
Underwater output effect, 45  
  
Vacuum stability, 132  
Vehicular aspects, 4  
Vented delay, 81, 84  
Vibration, 59  
  
Warhead, 45  
Wave shaping, 42  
Wire bridge, 25, 30, 51, 67, 78