

Safari Arms, Inc.

and its subsidiary

**Schuetzen
Pistol Works**

**.45 Automatic Pistols
*Owners Manual***

620-626 Old Pacific Highway SE
Olympia, WA 98513
(360) 459-7940

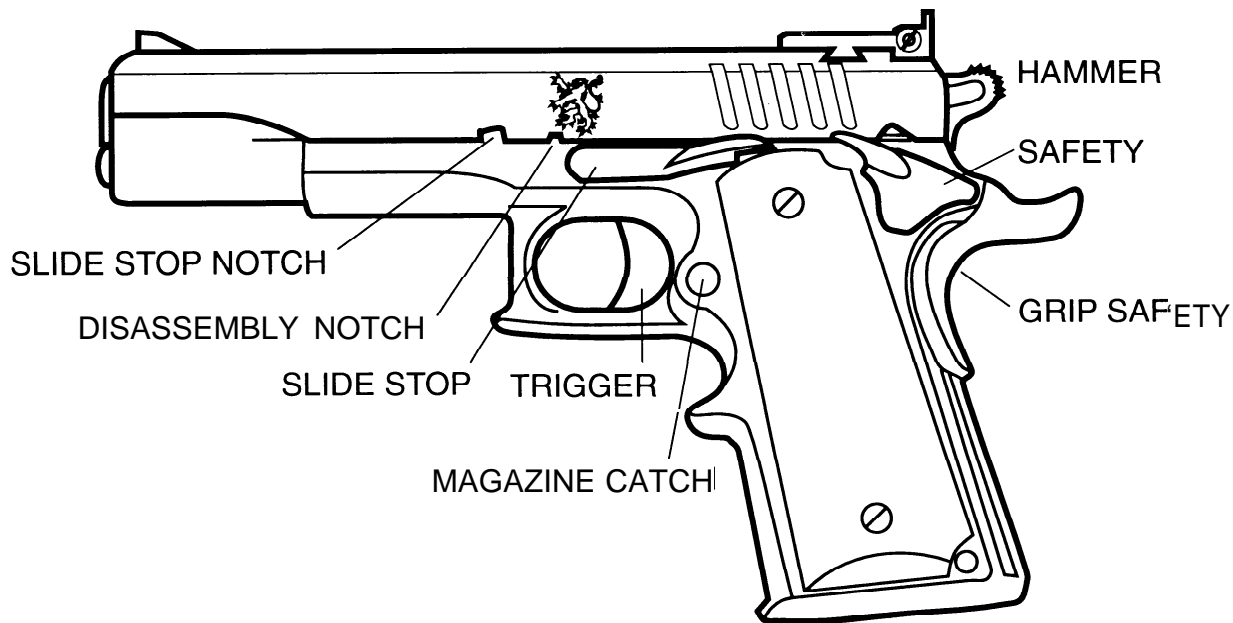

INTRODUCTION

We understand how excited you are to have received your Safari Arms handgun. **NOW, PUT IT DOWN. Don't pick it up until you have read and understood all instructions and cautions in this manual.**

An exploded diagram and parts list is included. For those unfamiliar with the 1911A1 Government Model design handgun, all instructions are accompanied by step-by-step illustrations. Please refer to the illustrations given and/or the exploded diagram for the part's location.

When shooting, WEAR HEARING PROTECTION

and WEAR SHOOTING GLASSES. For hearing protection you should wear ear muffs with a MINIMUM noise reduction factor of decibels. These handguns are LOUD and will damage your hearing if you are not careful.

The Safari Arms pistol is the direct result of dedication to the U.S. Government drawings and specifications. Safari Arms manufactures virtually every part in-house, using our own strict quality controls and rigid testing procedures. This guarantees you a custom pistol at production prices.

1911.45 PARTS LIST

- 1 Slide
- 2 LPA Adj. Rear Sight
- 3 LPA Front Sight
- 4 Extractor
- 5 Firing Pin
- 6 Firing Pin Spring
- 7 Firing Pin Stop
- 8 Barrel
- 9 Barrel Link
- 10 Barrel Link Pin
- 11 Barrel Bushing
- 12 Recoil Spring
- 13 Recoil Spring Guide
- 14 Recoil Spring Cap
- 15 Ejector
- 16 Ejector Pin
- 17 Disconnecter
- 18 Sear
- 19 Hammer
- 20 Hammer Strut
- 21 Hammer Strut Pin
- 22 Slide Stop
- 23 Magazine Catch
- 24 Magazine Catch Spring
- 25 Magazine Catch Lock
- 26 Hammer Pin
- 27 Sear Pin
- 28 Plunger Tube
- 29 Slide Stop Plunger
- 30 Plunger Spring
- 31 Safety Plunger
- 32 Thumb Safety
- 33 Trigger
- 34 Grip Safety
- 35 Sear Spring
- 36 Mainspring Housing
- 37 Mainspring Cap Pin
- 38 Mainspring Cap
- 39 Mainspring
- 40 Mainspring Retainer
- 41 Mainspring Housing Retainer Pin
- 42 Grip Screw
- 43 Grip Screw Escutcheon
- 44 Magazine
- 45 Barrel
- 46 Barrel

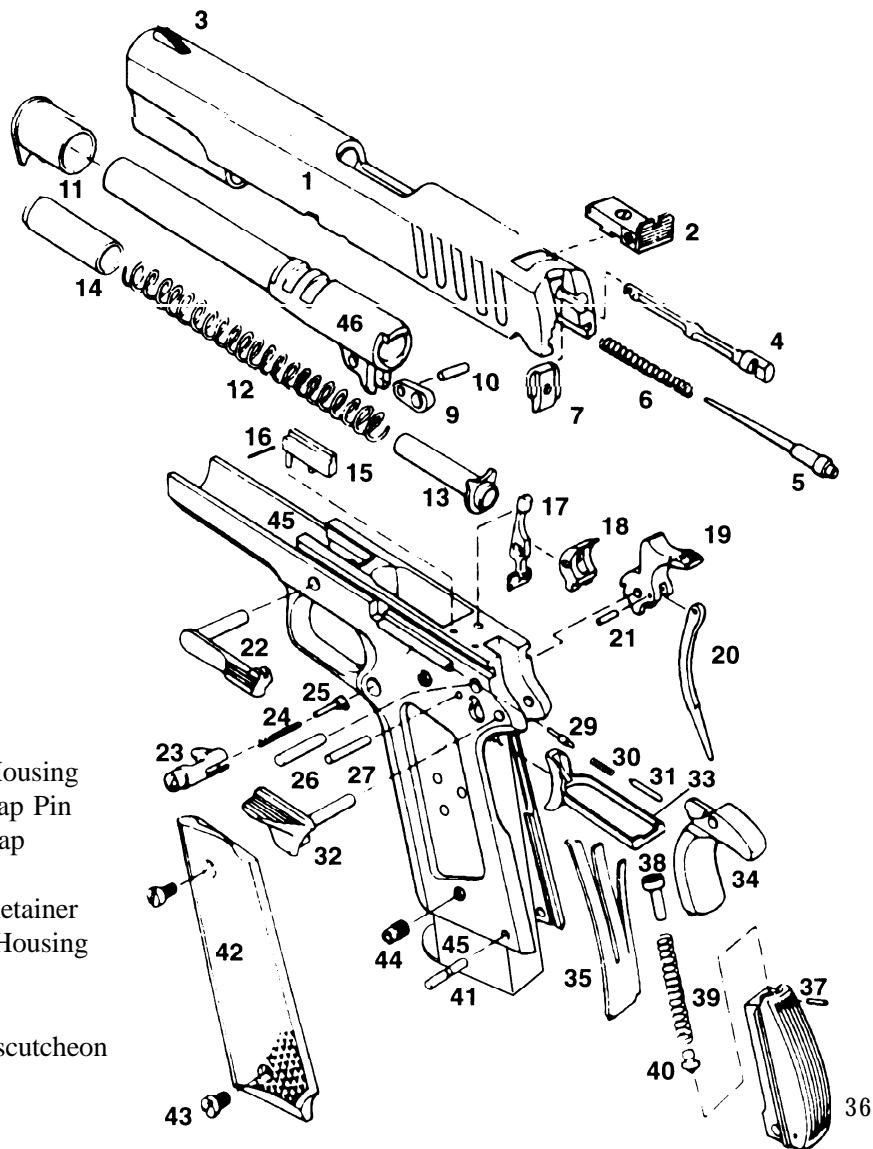

BASIC NRA RULES FOR SAFE GUN HANDLING

- 1. ALWAYS KEEP THE GUN POINTED IN A SAFE DIRECTION.**
- 2. ALWAYS KEEP YOUR FINGERS OFF THE TRIGGER UNTIL READY TO SHOOT.**
- 3. ALWAYS KEEP THE GUN UNLOADED UNTIL READY TO USE.**
- 4. ALWAYS TREAT YOUR GUN AS IF IT IS LOADED AND READY TO DISCHARGE.**

LEAD WARNING

Discharging firearms in poorly ventilated areas, cleaning firearms, or handling ammunition may result in exposure to lead and other chemicals known to cause birth defects, reproductive harm, cancer, and other serious physical injury. Have adequate ventilation at all times. Wash hands thoroughly after exposure.

WARNING:

This product is classified as a lethal weapon. Failure to read and properly execute the instructions and warnings in this manual could result in serious injury, death or damage to property

Do not attempt to practice loading or unloading with live ammunition without a thorough understanding of the safe operation of this pistol.

Always treat a firearm as if it were fully loaded.

Always store and carry this product empty, with the

hammer forward on an empty chamber. Failure to do so could result in an unintentional discharge.

Keep out of reach of children.

When you squeeze the trigger, you must expect the pistol to fire and take full responsibility for your actions.

Read through the entire manual before attempting to use this product.

TABLE OF CONTENTS

Exploded View and Parts List, 1911 .45 ACP	3
Basic Rules for Safe Gun Handling, Lead Warning, Manufacturer's Warning	4
Rules of Safety	6
Ammunition	7
Basic Description of Mechanism	10
How to Check if Your Weapon Is Loaded	11
Preparing Your Pistol for Firing	11
Safety and Gun Handling	13
Matchmaster "Captive" (single-pin): Disassembly, Cleaning and Reassembly	15- 19
Matchmaster (2-Piece Guide Rod System): Disassembly, Cleaning and Reassembly,	20 - 25
Matchmaster (One-Piece Undrilled Guide Rod System): Disassembly, Cleaning and Reassembly	26 - 30
Big Deuce: Disassembly, Cleaning and Reassembly	31-35
Enforcer and Cohort: Disassembly, Cleaning and Reassembly	36 - 40
Manufacturer's Warranty Instructions,	41
Tips from Your Pistolsmith	42

How to Determine Your Recoil System Type

The Safari Arms Matchmaster™ has been modified over the years, and has been produced with three different recoil systems. Instructions are provided for all three.



A hex-head opening means you have a two-piece guide rod system (page 20).

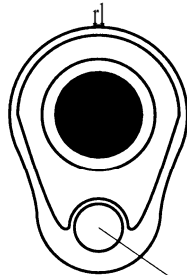

A smooth guide rod end means you have either a captive or a one-piece undrilled system, so...

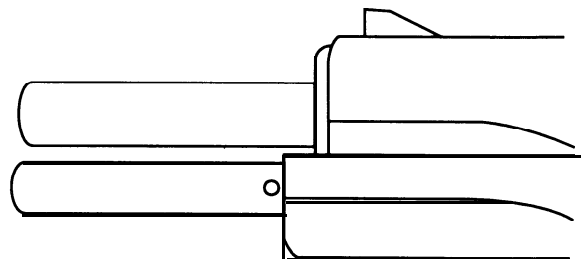

move the slide back until the slide stop engages. Look at the guide rod. If there is a tiny hole drilled through it, you have a captive system (page 15). If there isn't, you have the undrilled system (page 26).

RULES OF SAFETY

NOTICE: Safari Arms Inc., Olympic Arms Inc. and Schuetzen Gun Works shall not be responsible for any death, physical injury or property damage that is the result of the proper or improper use of this product.

1. Always treat this and any other firearm as if it were loaded.
2. Never point this or any other firearm at anything you do not intend to shoot. Keep muzzle pointed in a safe direction.
3. **NEVER** take anyone's word that a firearm is unloaded. **Clear it yourself with your finger off the trigger and the muzzle pointed in a safe direction.** Remove the magazine, lock the slide open and visually check to ensure that no round is chambered.
4. Always make sure the pistol is unloaded and the slide is latched open before laying it down or handing it to someone else.
5. **Never carry this pistol cocked, loaded and ready to fire.** This practice is dangerous, and can easily result in an unintentional discharge.
6. Always make sure that this firearm is in top working condition and that no internal parts have been damaged as a result of corrosion, improper maintenance or abuse. If evidence of these conditions is apparent, have your pistol checked by a competent gunsmith prior to use.
7. Never leave a loaded pistol unattended.
8. **Make sure that your backstop is adequate to stop your bullets prior to shooting.**
9. Make sure all other shooters and bystanders are well away from the ejection port. Empty cases are hot, and are ejected with great force. They may cause injury if someone is struck.
10. Obey all range rules at all times.
11. Always wear adequate hearing and eye protection when using any firearm
12. While on the range, be sure to carry this pistol cleared, with the slide locked open and the muzzle pointed in a safe direction until you are ready to shoot.
13. Always make sure that the barrel and action are clear of obstructions. Shooting a blocked firearm can result in serious injury, death and damage to the weapon.
14. Never drink alcoholic b or take drugs prior to or during shooting or handling of this or any other firearm.
- 15¹ Seek a doctor's advice if you are taking medicine prior to engaging in any shooting activity
16. Keep the safety on when pistol is loaded and cocked, until ready to fire. Immediately unload and clear this

pistol when shooting sequence has been completed.

17. Never shoot at any hard or flat surface, such as rock or water. The resulting ricochets could result in physical injury, death or property damage.
18. Never put your finger in the trigger guard until you are ready to fire.
19. Always make sure your pistol is unloaded before cleaning.
20. Never force a jammed action., This could cause a round to explode resulting in physical injury and damage to the pistol.
21. If a firearm fails to fire when the trigger is pulled, as

a result of slow primer ignition (hangfire), keep muzzle pointed downrange for a minimum of 30 seconds. If the round does not fire, remove the magazine, clear the weapon and examine the ejected, unfired cartridge. If the indentation from the firing pin is off center, light or absent, take the pistol to a competent gunsmith. If the indent appears normal compared to other rounds, assume the round is faulty, separate it from the other cartridges, reload and continue shooting.

22. Never use this pistol in any manner other than that for which it was specifically intended.
23. Never indulge in “horseplay” while holding any firearm.

AMMUNITION

1. Use only high-quality, original U.S. factory-manufactured ammunition. Don't oil cartridges. Don't spray aerosol lubricants or cleaners directly onto your cartridges, or where excess spray may flow into contact with them. Lubricants or other foreign matter on cartridges can cause potentially dangerous ammunition malfunction. Use only ammunition of the caliber for which your firearm is chambered. The proper caliber is engraved on the barrel; never try to use any other caliber.
2. The use of reloaded, “remanufactured:” aluminum cased, hand-loaded or other non-standard ammunition voids all warranties. Reloading is a science and improperly loaded ammunition can be dangerous. Severe damage to the pistol and serious injury to the shooter or to others may result. Always use ammunition that complies with the industry performance standards established by the Sporting Arms and Ammunition Manufacturers' Institute, Inc. of the United States (SAAMI).

3. Firearms may be severely damaged and serious injury to the shooter or bystanders may result from any condition causing excessive pressure inside the barrel or chamber during firing. Excessive pressure can be caused by powder overloads, an obstruction in the barrel, or by the use of defective cartridges. Never use dirty, corroded or damaged cartridges - they can lead to a burst cartridge case and damage to the firearm and to the shooter as a result of the explosive escape of high-pressure propellant gases within the firearms mechanism.

4. Immediately stop shooting and check the barrel for a possible obstruction whenever:

. You have difficulty in, or feel unusual resistance in chambering a cartridge, or

. A cartridge misfires (fails to go off), or

. The mechanism fails to extract a fired cartridge case.

. Unburned grains of powder are discovered spilled in the mechanism, or

. A shot sounds weak or “funny”

In such circumstances it is possible that a bullet is lodged part-way down the barrel. Firing a subsequent bullet into the obstructed barrel can wreck the firearm and cause serious injury to the shooter or bystanders.

5. Bullets can become lodged in the barrel -

. If the cartridge has been improperly loaded without propellant powder, or if the powder fails to ignite. (Primer ignition alone will push the bullet out of the case, but does not generate enough energy to push it completely out of the barrel).

. If the bullet is not properly seated tightly in the cartridge case. When such a cartridge is extracted from the chamber without being fired, the bullet may be left behind in the bore. Subsequent chambering of another cartridge may push the first bullet further into the bore.

6. If there is any reason to suspect that a bullet is obstructing the barrel, **immediately unload the firearm and look through the bore.** It is not sufficient to just look in the chamber. A bullet may be lodged some distance down the barrel where it cannot easily be seen. If a bullet is in the bore, ***do not attempt to shoot it out by using another cartridge, or by blowing it out with a blank,*** or a cartridge from which the bullet has been removed. Such techniques can generate excessive pressure, wreck the firearm and cause serious personal injury.

If the bullet can be easily removed with a cleaning rod, (using hand pressure only, never “hammer” a bullet lodged in the bore), clean any unburned powder grains from the bore, chamber and mechanism before resuming shooting. If the bullet cannot be dislodged by tapping it with a cleaning rod, take the pistol to a gunsmith.

7. Dirt, corrosion, or other foreign matter on a cartridge can cause difficulties with chambering and may cause the cartridge case to burst upon firing. The same is true of cartridges which are damaged or deformed.
8. **Don't oil your cartridges**, and be sure to wipe the chamber clean of any oil preservative before you start shooting. Oil interferes with the friction between cartridge case and chamber wall that is necessary for safe functioning, and subjects the pistol to stress similar to that imposed by excessive pressure.
9. Use lubricants sparingly on the moving parts of your firearm. Avoid excessive spraying of any aerosol gun care product, especially where it may get on ammunition. All lubricants, and aerosol spray lubricants in particular, can penetrate cartridge primers and cause misfires. Some highly penetrative lubricants can also migrate inside cartridge cases and cause deterioration of the propellant powder. When the cartridge is fired, the powder may not ignite. If only the primer ignites, there is a danger that the bullet may become lodged in the barrel.
10. 1911-style pistols were designed to function best with bullets that have a smooth contoured nose, seated to an overall length of 1.260 to 1.270 inches (1.270 is the maximum).

Shorter, blunter ammunition, such as hollow points, will normally function best if the barrel is and polished, by a competent pistolsmith, specifically for the bullet configuration most desired. Throating and polishing are standard on all Safari Arms pistols.

When cartridges fail to feed, check the following:
 - A. Substandard ammunition.
 - B. Magazine is poor quality, or feed lips are damaged.
 - C. Cartridge overall length too short.
 - D. Bullet nose too blunt.
 - E. Slide is short-stroking. Ammo charge is not to SAAMI specifications.

NOTE: 95% of all autopistol malfunctions are due to ammunition or defective magazines.

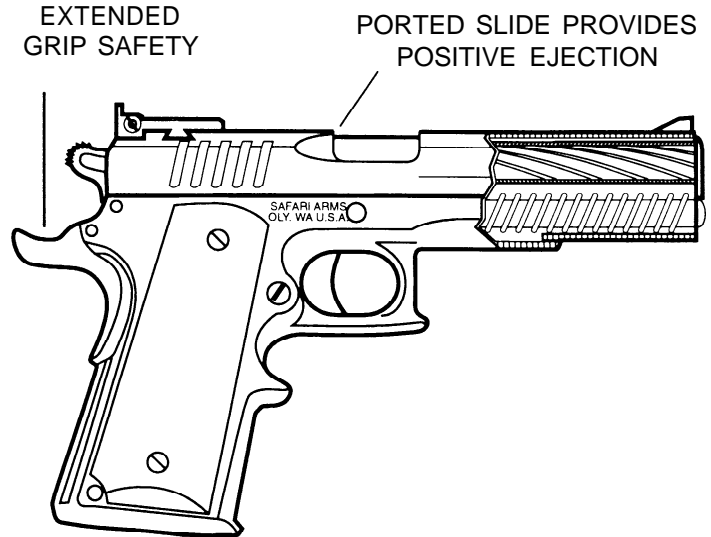
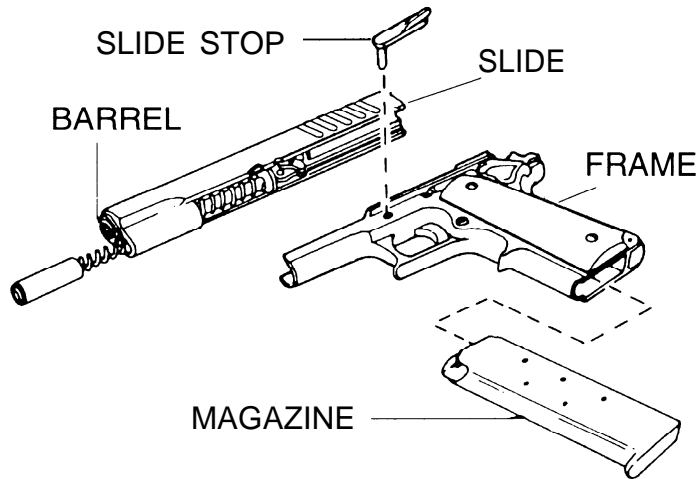

BASIC DESCRIPTION OF MECHANISM

The 1911 .45 ACP has three main parts: frame, barrel and slide.

The frame is fitted with guides in which the slide operates. Its grip is hollow to permit insertion of the magazine, which is retained by the magazine catch.

The barrel has two transverse locking ribs on its rear upper surface. They lock onto corresponding slots on the inside of the slide when in firing position. The lower rear end of the barrel is attached to the frame by a link and pin. It can, in consequence, move a limited distance lengthwise and downwards.

The slide mounts on the frame from the front end, and the distance of its rearward movement is controlled by the frame abutment, which prevents it from being thrown off the frame.

When the barrel and slide together are mounted on the frame and the slide stop is in place, the slide stop pin passes through the frame and the barrel link, locking slide, barrel and frame together. The top of the slide stop is serrated to provide positive traction for releasing the slide from the open position.

HOW TO CHECK IF YOUR WEAPON IS LOADED

Every time the pistol is picked up and anytime someone hands you a gun, the **FIRST THING** you must do is **CHECK TO SEE IF THE GUN IS LOADED!** It is the **FIRST** thing that every smart shooter does.

Pick up the pistol by its grip *with your finger off the trigger*, point it away from you, at the floor or some other safe direction.

Remove the magazine by depressing the magazine catch.

Grasp the grip grooves on the slide and pulling the slide to the rear as shown, open the breech. This will expose the chamber at the rear of the barrel and the cartridge feeding area behind and below the barrel. By looking down into the opening in the slide ejection port and into the chamber at the rear of the barrel it is easy to see if the chamber is empty or if there is a cartridge in place.

If there is a cartridge in the chamber, **UNLOAD THE GUN** by pulling the slide all the way to the rear. The cartridge will either fall down the magazine well or be ejected through the ejection port. **BE SURE THAT IT DOES.** Ease the slide forward.

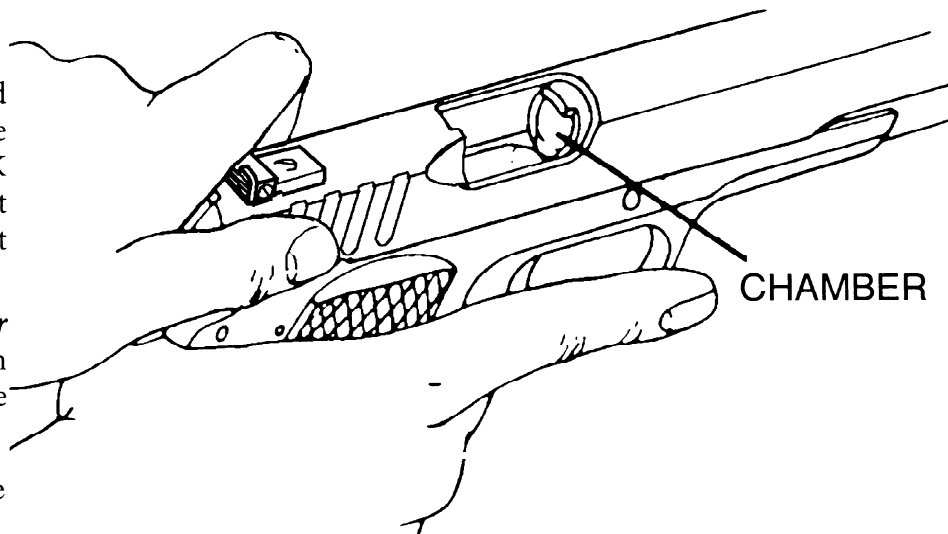

PREPARING YOUR PISTOL FOR FIRING Loading the magazine

Grasp it firmly in your left hand (see picture).

Press down the follower (or, after a round has been inserted, the top cartridge) with your left thumb.

Insert cartridges with the right hand, pressing the base

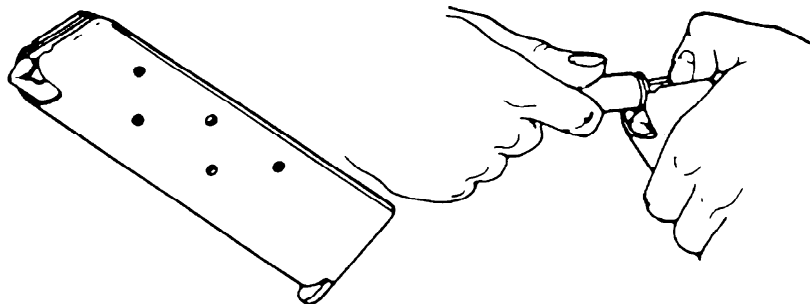

of a cartridge down against the front end of the follower and slide backward in one smooth motion under the retaining lips.

This is done with one cartridge after another until the magazine is full. Each factory-supplied magazine has holes in the body which will show how many cartridges are in place. Having loaded one magazine, you can see why owning several spare magazines is desirable and also, how easily and quickly the pistol can be reloaded when you have a supply of loaded magazines. Loading a magazine is simple and becomes even easier with a little practice.

Insert the magazine

Be sure it locks in place. There will be an audible click.

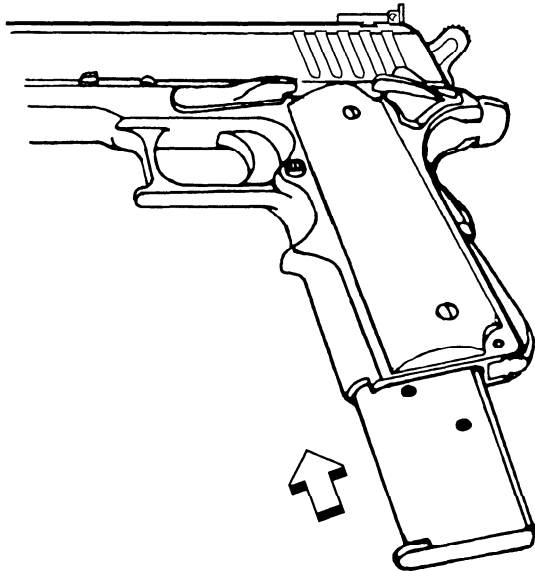

Load the pistol this way:

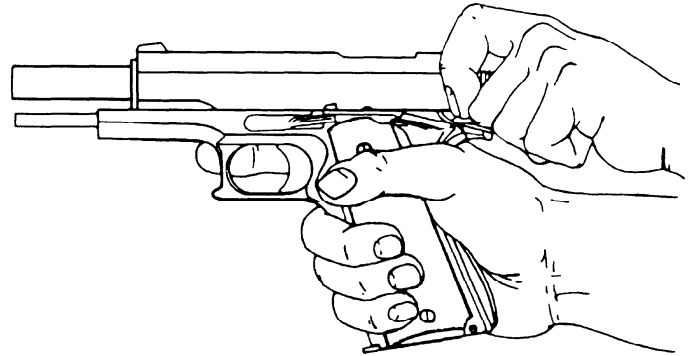

Load the pistol in this way, with the hand behind the slide as shown, and the finger out of the trigger guard. The effort needed to pull back the slide can be reduced if the hammer is first cocked. Pull the slide completely to the rear. When the slide is as far to the rear as it will go, release it.

The slide, when released, moves forward, propelled by the recoil spring. The breech face of the slide pushes the first cartridge into the chamber, thus loading the pistol. The slide should be pulled completely to the rear, and released from the furthest-back position, allowing the recoil spring to close and lock the pistol with no interference from the hand. **Be careful. At this point the pistol is ready to fire.** If you do not plan to immediately shoot the pistol, engage the safety lock. The pistol is fired by steady rearward pressure on the trigger; one

pull for each round until the magazine is empty. After the last shot is fired, the pistol will remain locked open ready for a freshly loaded magazine. It will be in this position:

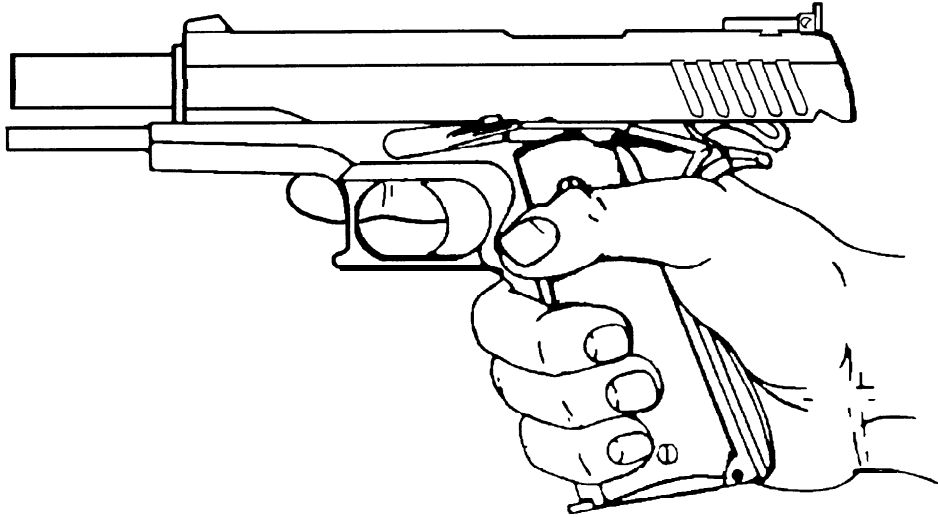

This feature tells the shooter that his pistol is empty, and permits rapid reloading. Press the slide stop down out of its locking notch to allow the slide to move forward. If a loaded magazine is inserted and the slide stop is pushed down, the slide will load a fresh cartridge from the magazine into the chamber, and the pistol is ready to fire.

SAFETY & GUN HANDLING

A gun is a lethal instrument. It is no safer than the person handling it. There are many rules about gun

handling, but the most important one is: **WATCH THAT MUZZLE.** Do not point it at anything you do not intend to shoot. Check every gun to see if it is loaded, with your fingers off the trigger and the muzzle pointed in a safe direction, every time you touch one. Watch what you shoot at when you are shooting. Keep the gun pointed in a safe direction when you do not intend to shoot it.

On a shooting range, lock your gun in the open position whenever you are not firing it. This tells everyone that you have a gun in safe condition. Practice common sense and range courtesy, and you will find yourself welcome among shooters.

ASK YOURSELF: what will the bullet strike after it passes through the target? Safe gun handling also means

being certain of your backstop. If you are going to turn all that firepower loose, you'd better be certain that something will stop it.

All **Safari Arms** pistols are provided with a positive safety lock. When the safety lock is pushed into the upward position (see second picture), it snaps into a notch on the slide. At the same time, a stud on the inner face blocks motion of the sear when in the full cocked position. This safety can only be applied when the hammer is cocked.

Safari Arms recommends that you carry your pistol

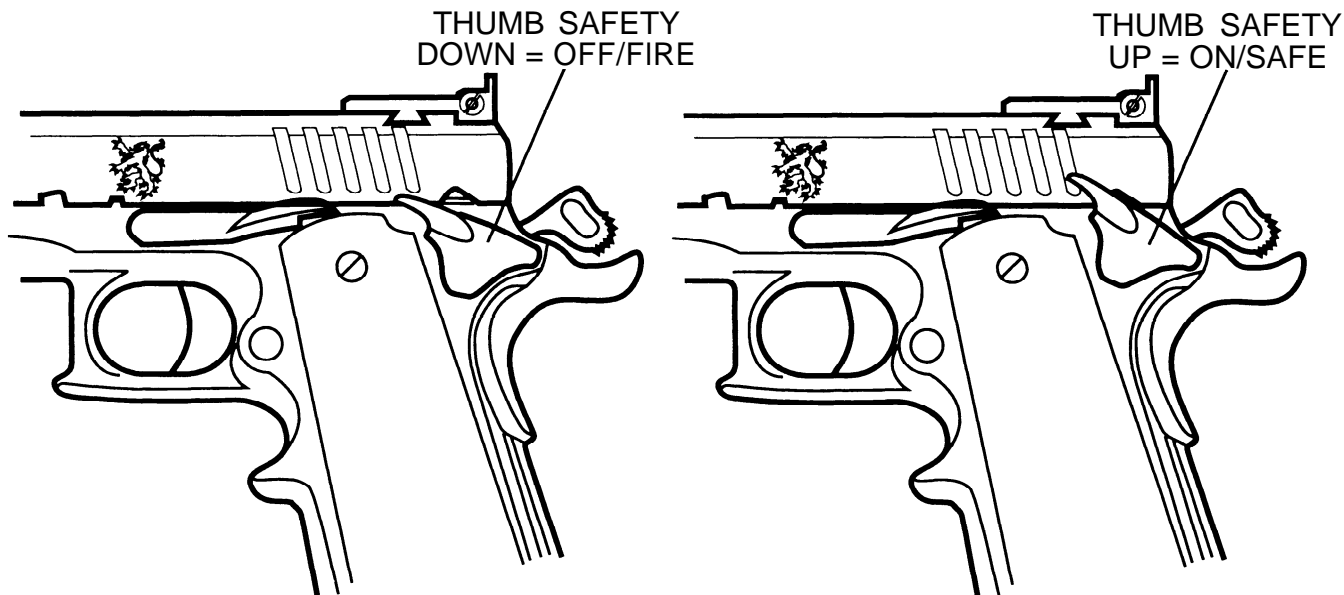

with the hammer down on an **EMPTY CHAMBER**. This allows a loaded magazine to be safely inserted into the pistol.

*Carry your .45 with the
hammer down on an
empty chamber.*

MATCHMASTER 'CAPTIVE' (Single-pin)

For Matchmaster pistols manufactured after August, 1995.

Remove magazine and check to make sure pistol is unloaded.

Lock the slide back with the slide stop. Into the exposed hole in the side of the guide rod, insert the takedown tool, a bent paper clip or a short pin or nail.

While holding the takedown tool or pin in place, ease the slide forward until the tool or pin takes up the tension (the spring tension will hold it in place).

Move the slide forward a little until the takedown notch is just above the slide stop tab.

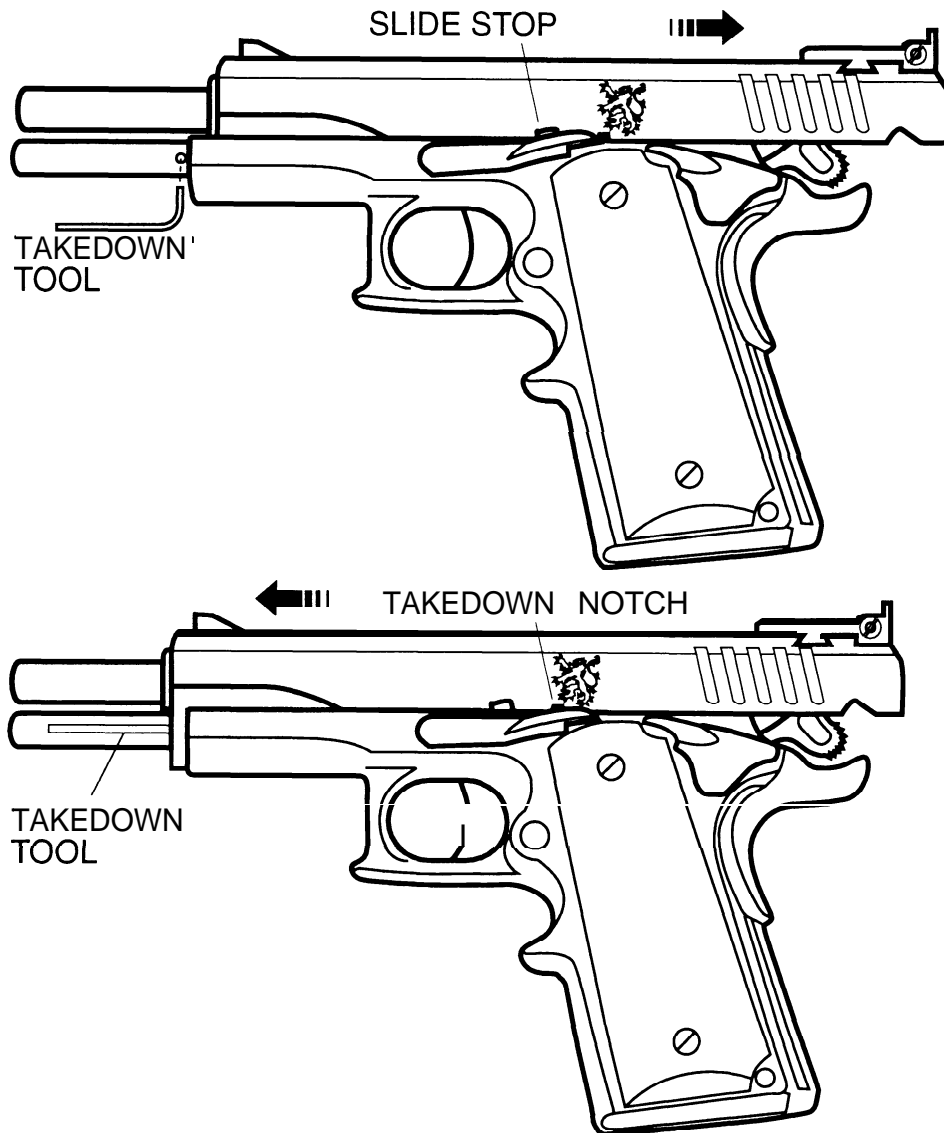

Remove the slide stop by pulling it straight out - it can be started by pressing on the end that protrudes from the opposite side of the frame.

Remove entire top end of pistol by moving it forward off the frame.

The recoil system will lift out as a unit from the underside of the barrel.

Rotate barrel bushing counter-clockwise.

Flip barrel link forward toward muzzle.

Remove barrel and bushing by pulling them out of the end of the slide.

Leave the hammer cocked.

Your Matchmaster™ with “captive” guide rod is now disassembled for cleaning. No further disassembly is necessary.

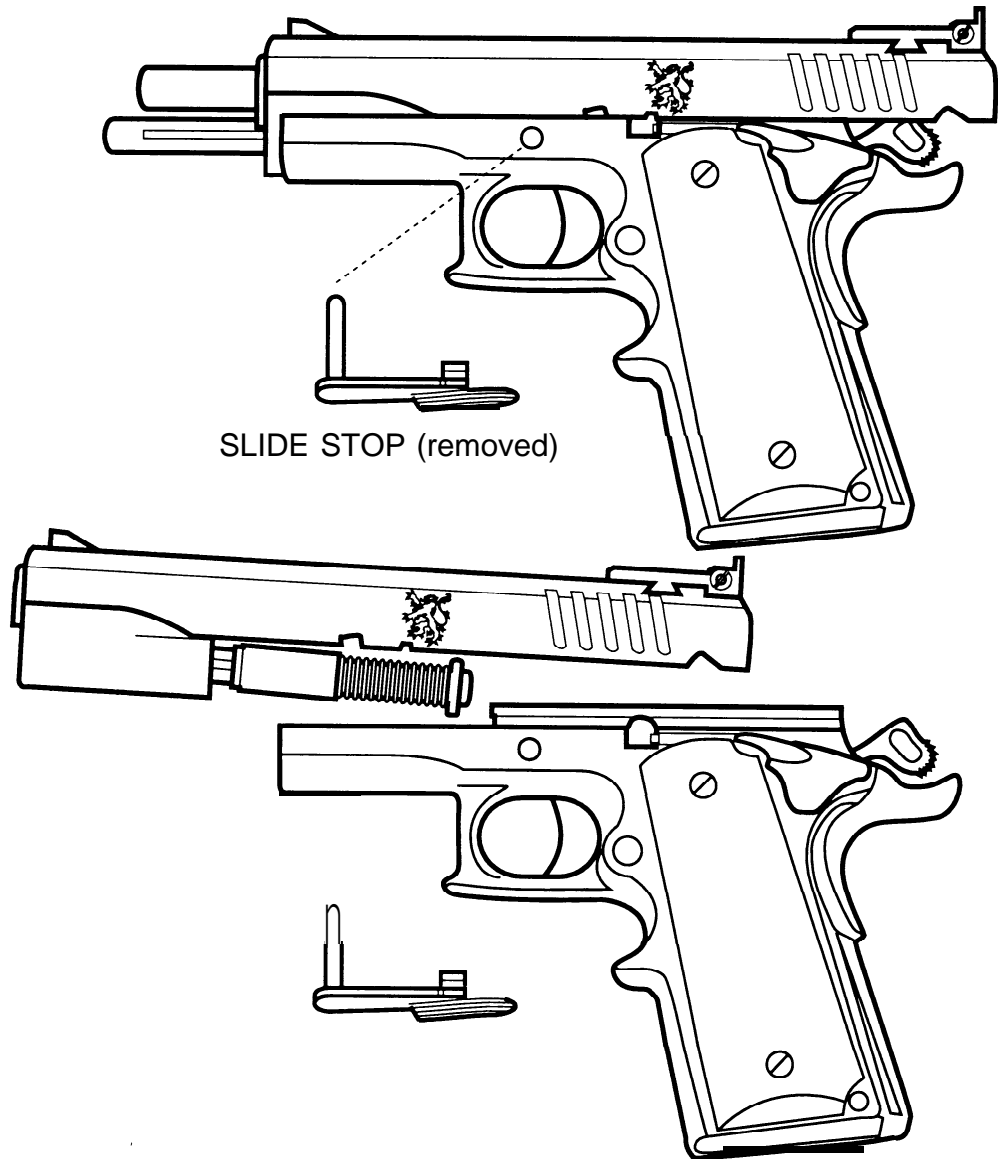

Clean and lubricate using:

a stainless or polished steel cleaning rod (avoid using an aluminum or wooden rod - they can collect abrasive residue);

a brass bore brush which threads onto the cleaning rod;

a supply of patches (ready-made, or cut out of cotton or flannel rags) and several rags;

an old towel or carpet scrap for your working surface;

an old toothbrush or a brass-bristled parts brush; and
“CLP” or suitable gun oil.

Swab the bore (inside of the barrel) by pushing a dry patch through it with the cleaning rod, **always entering from the rear**. The first pass will push out loose fouling. Then, using a clean patch dampened with “CLP”, do the same thing again. DO NOT allow the rod to scrape the edges as it passes through the bore. If you damage the rifling, the pistol’s accuracy will be affected.

Let the “CLP” work on the bore deposits while you use a rag dampened with more “CLP” and scrub and wipe off the inside of the slide (especially around the breech and the locking lugs - the lugs on the inside of the slide that match up to the indentations on the barrel), the outside of the barrel, and the slide stop.

Wipe off the black residue on the face of the breech around the firing pin hole and under the hook of the extractor. Wipe off any residue on the barrel bushing and recoil spring guide as well. Wipe off any excess oil.

After the “CLP” has had a chance to loosen the deposits in the bore, run a dry patch through the barrel, use a

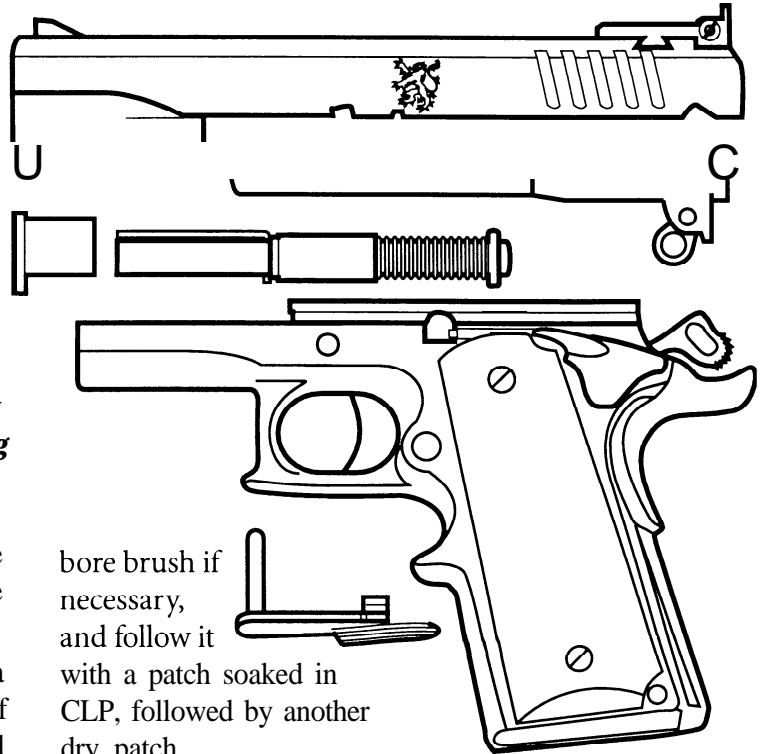

bore brush if necessary, and follow it with a patch soaked in CLP, followed by another dry patch.

With a quality lubricant designed for stainless steel (such as FP-10, Energy Release, etc.), put a few drops on the running, or function, surfaces *in the slide only*; i.e., where the barrel rides, the slide rail surfaces where they match the frame, and on the disconnecter ramp. These areas usually show wear and shiny patches. NEVER squirt oil into the frame.

Do not over-oil. It can be detrimental to the proper function of the pistol.

Matchmaster Reassembly

(with “Captive” recoil-spring guide system)

Turn slide upside down. Flip barrel link toward the muzzle and ease barrel into the slide until it seats on the locking lugs in the top of the slide.

Press barrel bushing into place and twist it clockwise to lock. Flip barrel link to the rear.

Insert recoil spring assembly into place from the back of the slide.

Note: because the spring is held under tension by the takedown tool or pin, you do not need to adjust its position relative to the slide and barrel; just make sure that the “ears” on the guide rod are properly seated against the barrel, and the spring cap is at least partially within the lower portion of the slide.

Flip barrel link to upright position.

Align the grooves in the receiver with the rails on the slide and press them together until the barrel link hole is visible through the hole for the slide stop. Insert the slide stop.

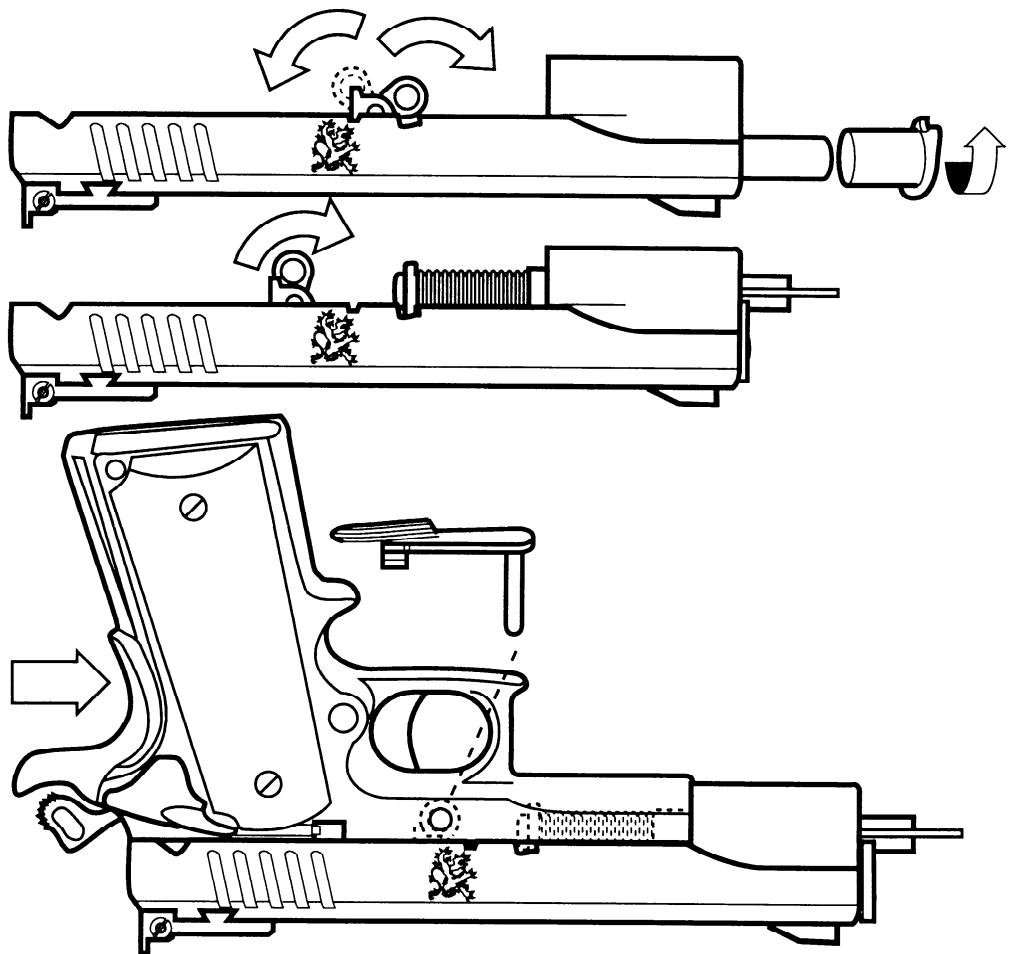

NOTE: Do not try to align the barrel link, the disassembly notch and the top of the slide stop all at the same time. Align the link first, insert the slide stop shaft, and then rotate the slide stop upward until it aligns with the disassembly notch.

Move slide to the rear until the semicircular protrusion on the back of the slide stop aligns with the semi-circular disassembly notch on the bottom of the slide. Exercise caution as you rotate the slide stop upward, or you will mar the finish.

Push inward on the slide stop until it snaps into place.

Push the slide a little further to the rear and move the slide stop into the slide stop notch.

Pull out the takedown tool or pin and ease the slide into battery. Lower the hammer.

The pistol is now ready to have a magazine inserted.

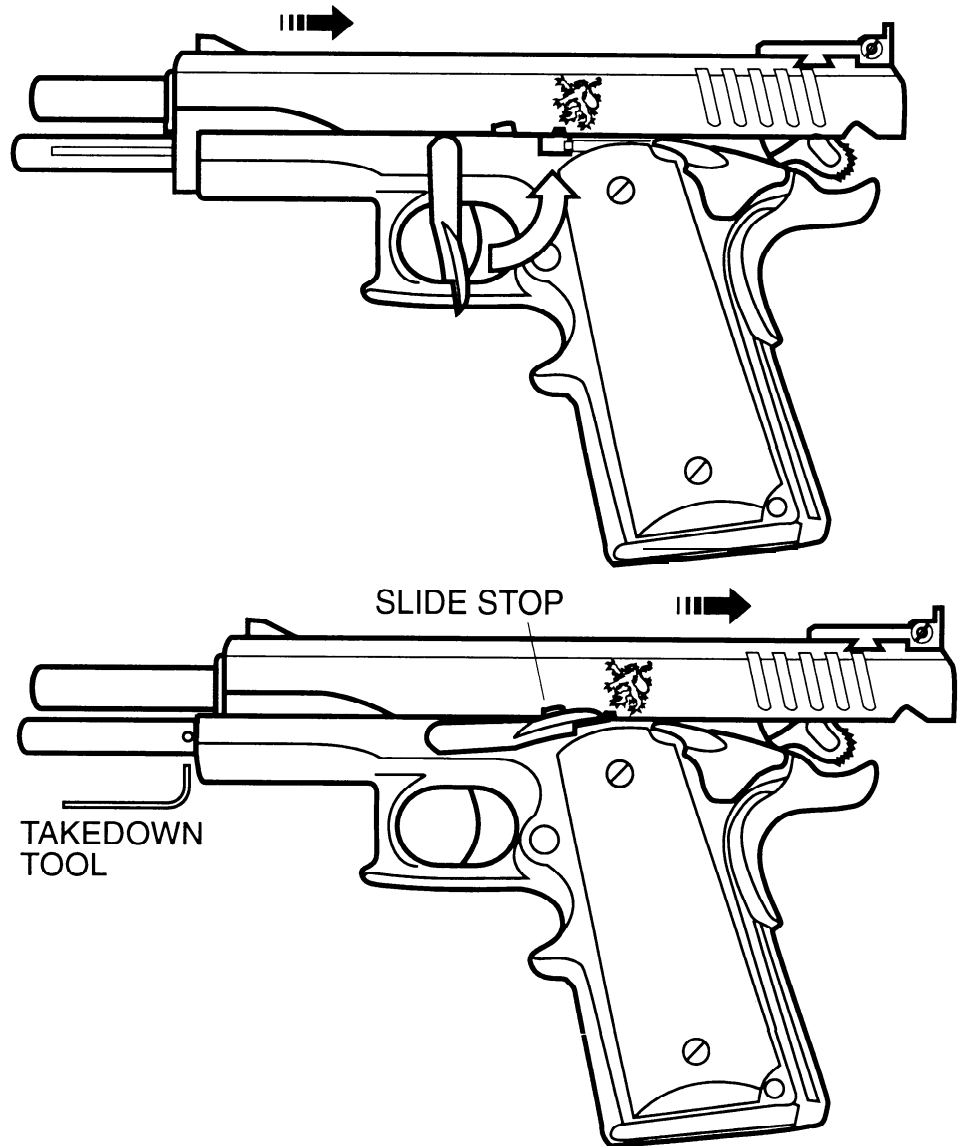

MATCHMASTER

2-piece guide rod

Remove magazine and check to make sure pistol is unloaded.

Lock the slide back with the slide stop. Insert allen wrench into the end of the guide rod; unscrew and remove.

Unlock slide and ease it back into battery.

Depress the recoil spring cap - using the bottom of the magazine works well.

Leave the hammer cocked.

While holding recoil spring cap down, rotate barrel bushing *clockwise*.

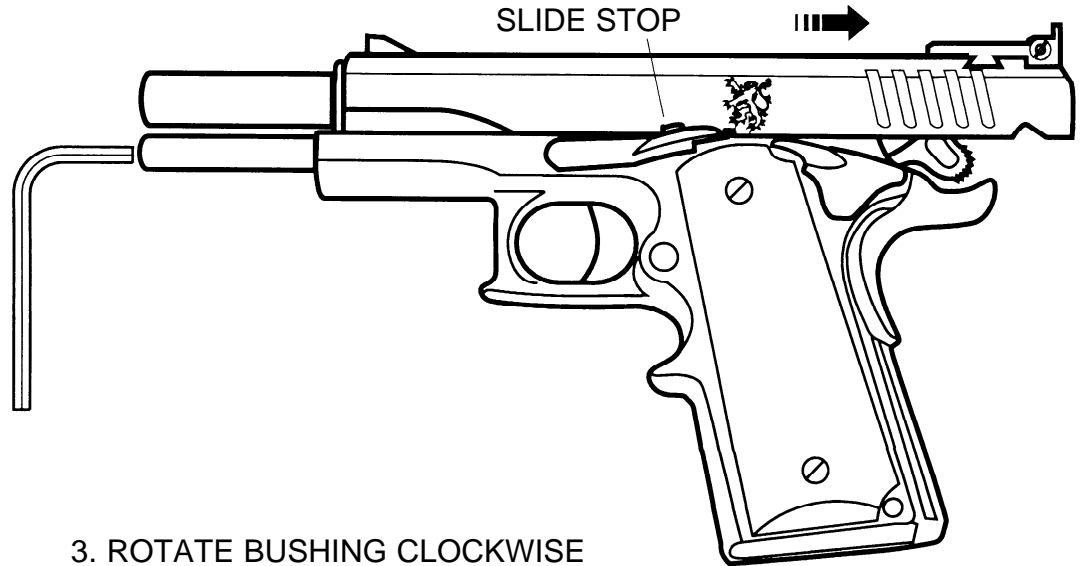

3. ROTATE BUSHING CLOCKWISE

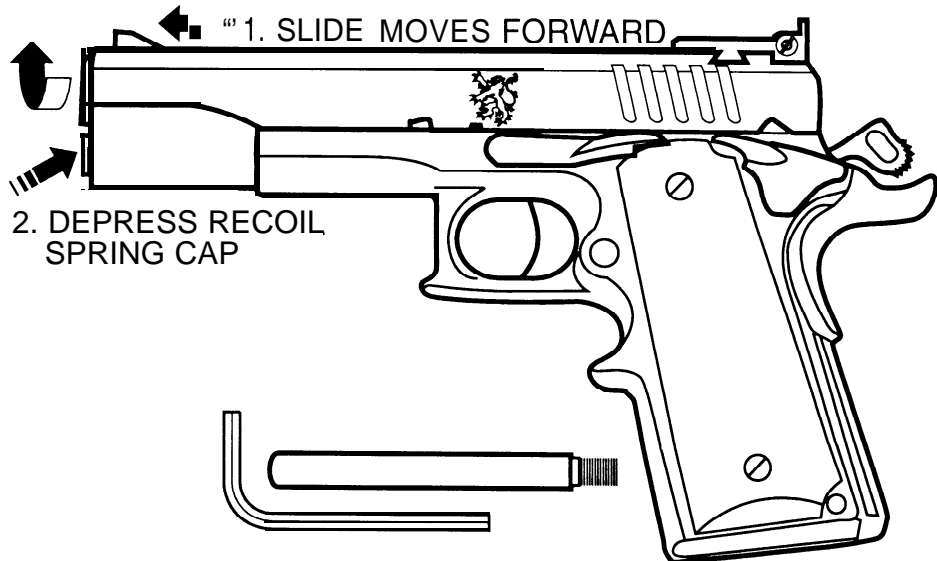

Control the spring cap, as it is under considerable pressure from the spring.

Ease the recoil spring cap out.

Move slide back until take-down notch is above slide stop tab.

Remove slide stop.

Remove slide (top end) by sliding forward off the frame.

Remove recoil guide end and spring from underside of slide/barrel.

Flip barrel link forward toward muzzle and remove barrel by pulling it out of the muzzle end of the slide. Be sure you leave the hammer cocked.

No further disassembly is necessary or advisable.

When re-assembling, make sure barrel link is flipped back (away from muzzle) before inserting slide stop.

Make certain you can see the barrel link hole through the slide stop opening.

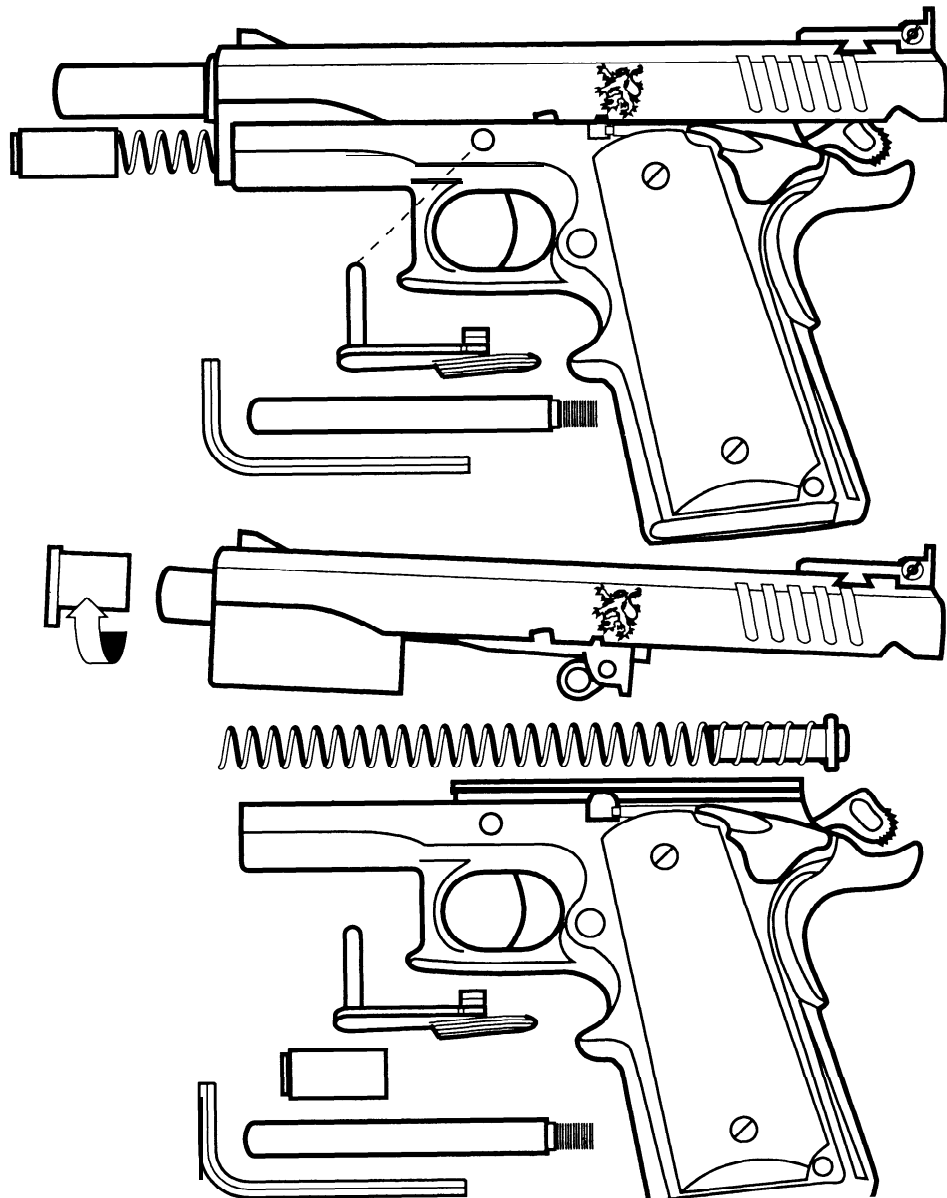

Clean and lubricate using:

a stainless or polished steel cleaning rod (avoid using an aluminum or wooden rod - they can collect abrasive residue);

a brass bore brush which threads onto the cleaning rod;
a supply of patches (ready-made, or cut out of cotton or flannel rags) and several rags;

an old towel or carpet scrap for your working surface;
an old toothbrush or a brass-bristled parts brush; and
“CLP” or suitable gun oil.

Swab the bore (inside of the barrel) by pushing a dry patch through it with the cleaning rod, **always entering from the rear**. The first pass will push out loose fouling. Then, using a clean patch dampened with “CLP”, do the same thing again. DO NOT allow the rod to scrape the edges as it passes through the bore. If you damage the rifling, the pistol’s accuracy will be affected.

Let the “CLP” work on the bore deposits while you use a rag dampened with more “CLP” and scrub and wipe off the inside of the slide (especially around the breech and the locking lugs), the outside of the barrel, and the slide stop.

Wipe off the black residue on the face of the breech around the firing pin hole and under the hook of the extractor. Wipe off any residue on the barrel bushing and recoil spring guide as well. Wipe off any excess oil.

After the “CLP” has had a chance to loosen the deposits in the bore, run a dry patch through the barrel, use a bore brush if necessary, and follow it with a patch soaked



in CLP, followed by another dry patch.

With a quality lubricant designed for stainless steel (such as FP-10, Energy Release, etc.) put a few drops on the running, or friction, surfaces *in the slide only*; i.e., where the barrel rides, the slide rail surfaces where they match the frame, and on the disconnecter ramp. These areas usually show wear and shiny patches. NEVER squirt oil into the frame.

Do not over-oil. It can be detrimental to the proper function of the pistol.

Matchmaster Reassembly

(with two-part recoil-spring guide system)

Turn slide upside down. Flip barrel link toward the muzzle and ease barrel into the slide until it seats on the locking lugs in the top of the slide.

Flip barrel link to the rear.

Insert the guide rod base, making sure that the “ears” on the guide rod are properly seated against the barrel.

Flip barrel link to upright position.

Thread the recoil spring onto the guide rod base from the front of the slide.

Align the grooves in the receiver with the lugs on the slide and press them together until the barrel link hole is visible through the hole for the slide stop. Insert the slide stop.

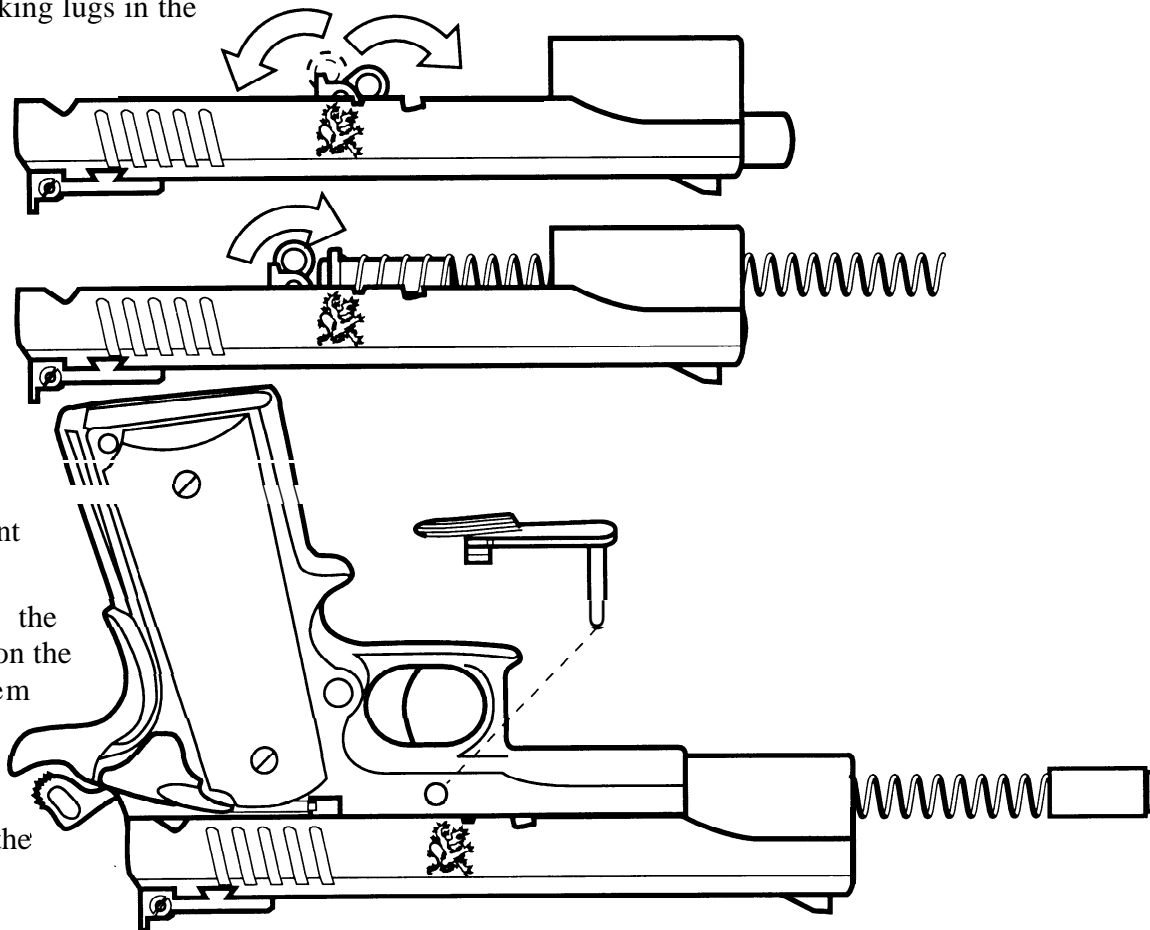

NOTE: Do not try to align the barrel link, the disassembly notch and the top of the slide stop all at the same time. Align the link first, insert the slide stop shaft, and then rotate the slide stop upward until it aligns with the disassembly notch.

Move the slide forward until it lines up flush with the muzzle. Place the recoil spring cap on the recoil spring.

With the pistol braced firmly on a padded surface (a carpet scrap works nicely), compress the spring into the slide while holding the slide in place and keeping the barrel bushing ready. An extra hand is helpful but not absolutely necessary.

Use the base of

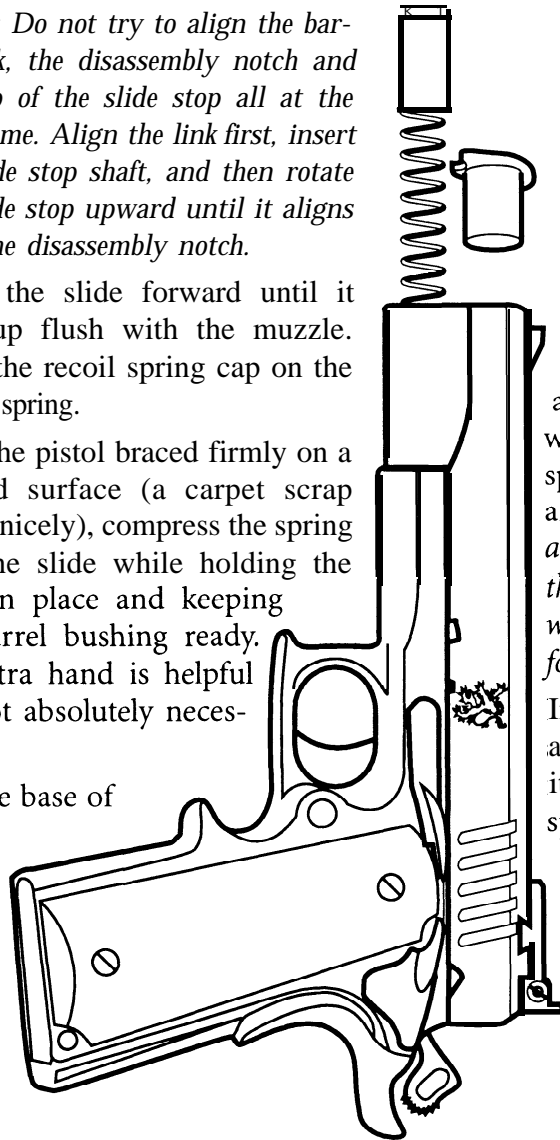

a magazine or a barrel bushing wrench to compress the recoil spring cap flush with the slide and muzzle. *Keep the muzzle aimed away from your face – if the spring gets away from you it will shoot out with considerable force.*

Insert the barrel bushing and twist clockwise to lock it in place. The recoil spring cap should snap into the bushing notch.

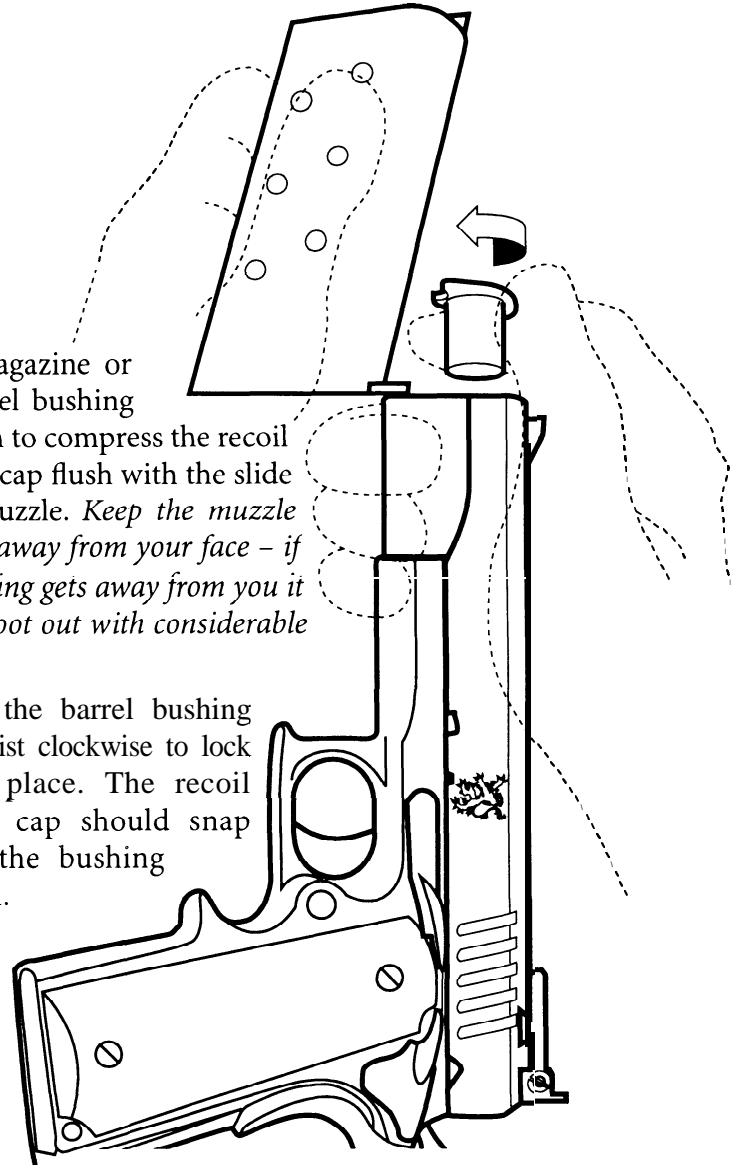

Press the front section of the two-part guide rod into the pistol, taking care not to kink or crush the recoil spring. Firmly tighten with the hex-head wrench.

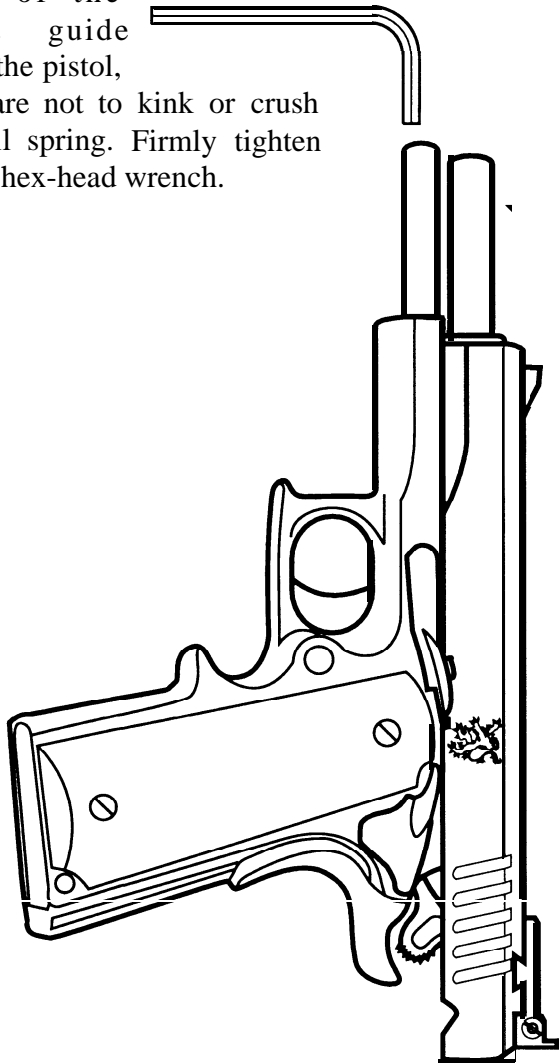

Move the slide to the rear until the slide stop lines up with the slide stop notch.

Then depress the slide stop and ease the slide forward into battery. Lower the hammer.

Your pistol is now ready for a fresh magazine.

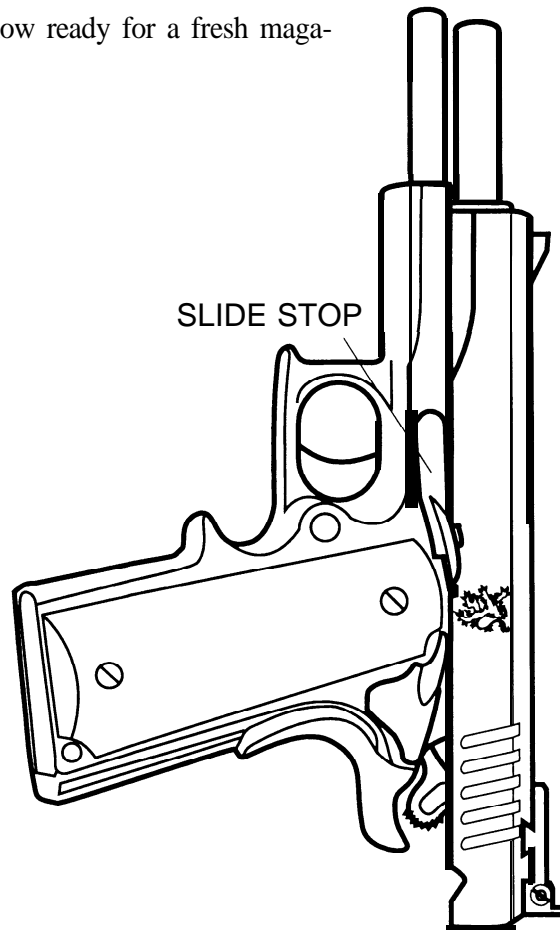

MATCHMASTER

One-piece guide rod, undrilled
(For Matchmasters manufactured before
1995).

Remove magazine and check to make sure
pistol is unloaded.

Cock the hammer and position the pistol
on a clean, padded solid surface (a scrap of
carpet is excellent). *Since all parts are **under**
spring tension, DO NOT point the front of
the pistol at your face or someone else's face
during disassembly and reassembly.*

Depress the recoil spring cap using the
bottom of the magazine works well. A barrel
bushing wrench (available at your local
sporting goods store) is better.

While holding recoil spring cap down,
rotate barrel bushing *clockwise*. **Control the
recoil spring cap.** It is under great pressure
from the spring.

Ease the recoil spring cap out. Remove the
recoil spring.

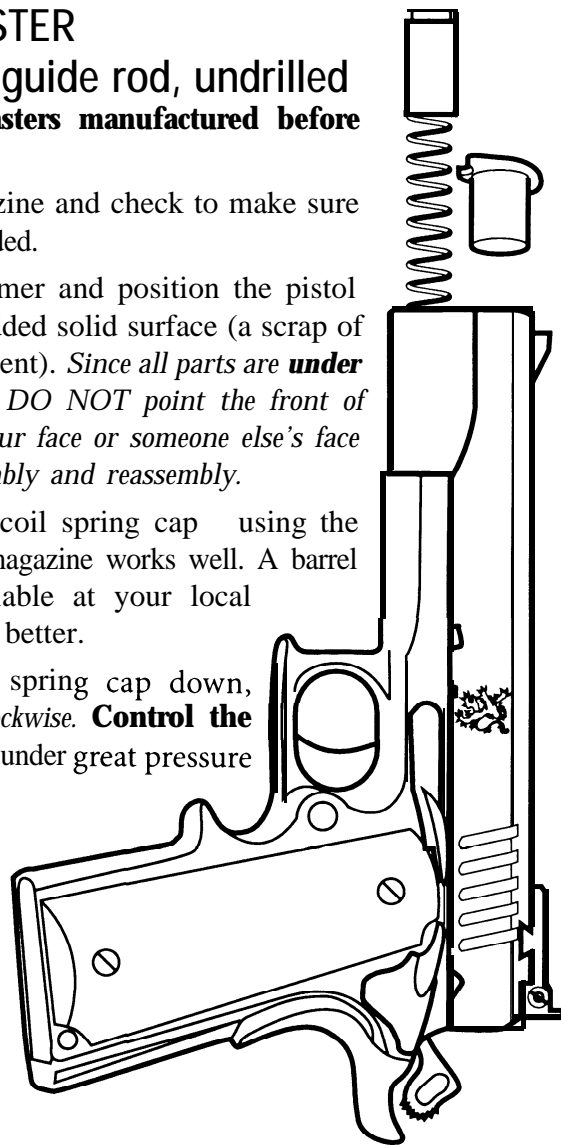
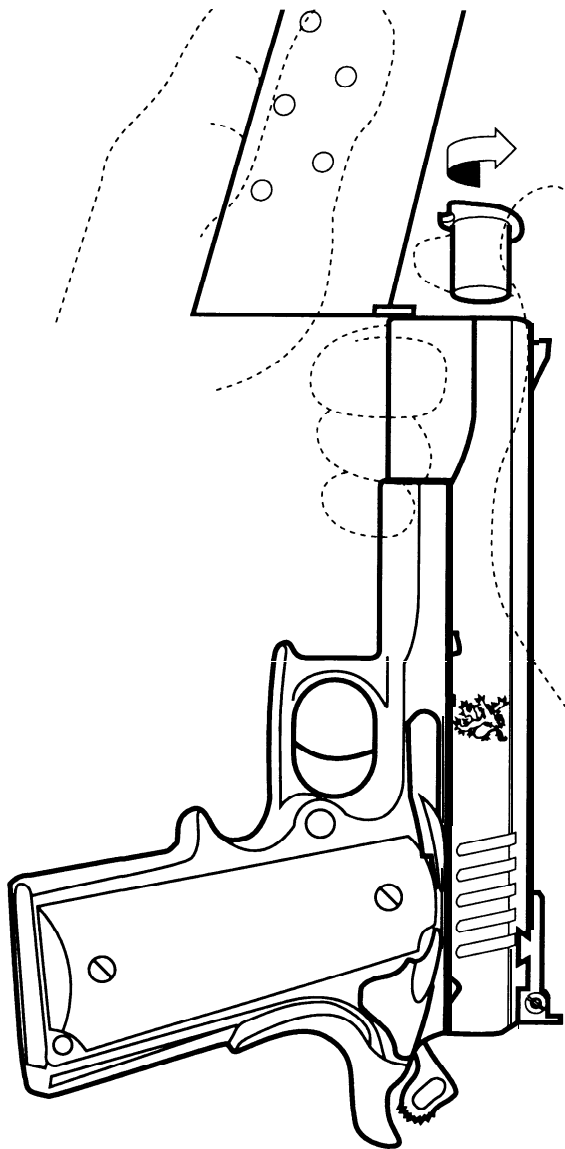

Move slide back until take-down notch is above slide stop tab.

Remove slide stop.

Remove slide (top end) by sliding forward off the frame.

Remove recoil guide end and spring from underside of slide/barrel.

Flip barrel link forward toward muzzle and remove barrel by pulling it out of the muzzle end of the slide.

Clean and lubricate, and reassemble by following the instructions on the next page.

When re-assembling, make sure barrel link is flipped back (away from muzzle) before inserting slide stop. **Make certain you can see the barrel link hole through the slide stop opening.**

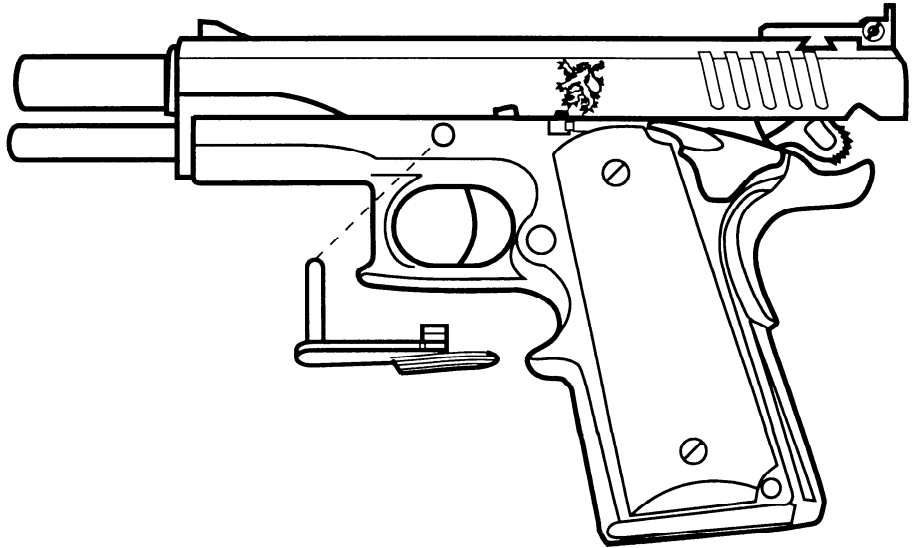

Clean and lubricate using:

a stainless or polished steel cleaning rod (avoid using an aluminum or wooden rod - they can collect abrasive residue);

a brass bore brush which threads onto the cleaning rod;

a supply of patches (ready-made, or cut out of cotton or flannel rags) and several rags;

an old towel or carpet scrap for your working surface;

an old toothbrush or a brass-bristled parts brush; and

“CLP” or suitable gun oil.

Swab the bore (inside of the barrel) by pushing a dry patch through it with the cleaning rod, ***always entering from the rear***. The first pass will push out loose fouling. Then, using a clean patch dampened with “CLP”, do the same thing again. DO NOT allow the rod to scrape the edges as it passes through the bore. If you damage the rifling, the pistol’s accuracy will be affected.

Let the “CLP” work on the bore deposits while you use a rag dampened with more “CLP” and scrub and wipe off the inside of the slide (especially around the breech and the locking lugs - the lugs on the inside of the slide that match up to the indentations on the barrel), the outside of the barrel, and the slide stop.

Wipe off the black residue on the face of the breech around the firing pin hole and under the hook of the extractor. Wipe off any residue on the barrel bushing and recoil spring guide as well. Wipe off any excess oil.

After the “CLP” has had a chance to loosen the deposits in the bore, run a dry patch through the barrel, use a

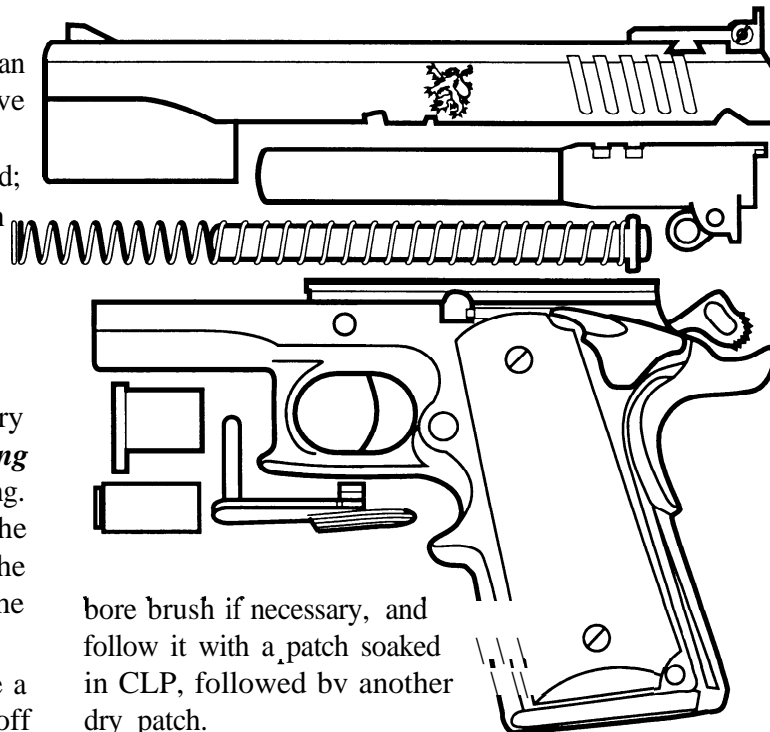

bore brush if necessary, and follow it with a patch soaked in CLP, followed by another dry patch.

With a quality lubricant designed for stainless steel (such as FP-10, Energy Release, etc.), put a few drops on the running, or friction surfaces in the slide i.e., where the barrel rides, the slide rail surfaces where they match the frame, and on the disconnecter ramp. These areas usually show wear and shiny patches. NEVER squirt oil into the frame.

Do not over-oil. It can be detrimental to the proper function of the pistol.

Matchmaster Reassembly

(with full-length guide rod system)

Turn slide upside down. Flip barrel link toward the muzzle and ease barrel into the slide until it seats on the locking lugs in the top of the slide.

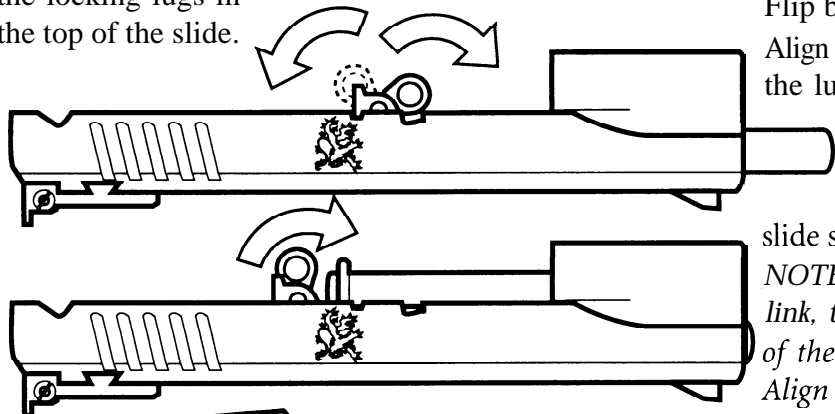

shaft, and then rotate the slide stop upward until it aligns with the disassembly notch. Be careful not to mar the finish on your pistol. The slide will move easily for alignment.

Move the slide forward until it lines up flush with the muzzle. Thread the recoil spring onto the full-length guide-rod. Place the recoil spring cap on the recoil spring.

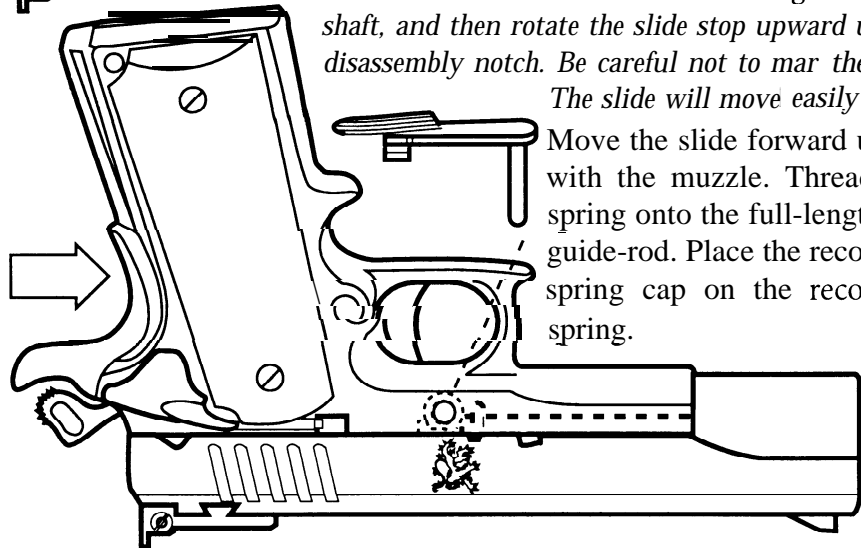

Flip barrel link to the rear.

Insert the full-length guide rod, making sure that the "ears" on the guide rod are properly seated against the barrel.

Flip barrel link to up-right position.

Align the grooves in the receiver with the lugs on the slide and press them together until the barrel link hole is visible through the hole for the slide stop. Insert the slide stop.

NOTE: Do not try to align the barrel link, the disassembly notch and the top of the slide stop all at the same time. Align the link first, insert the slide stop

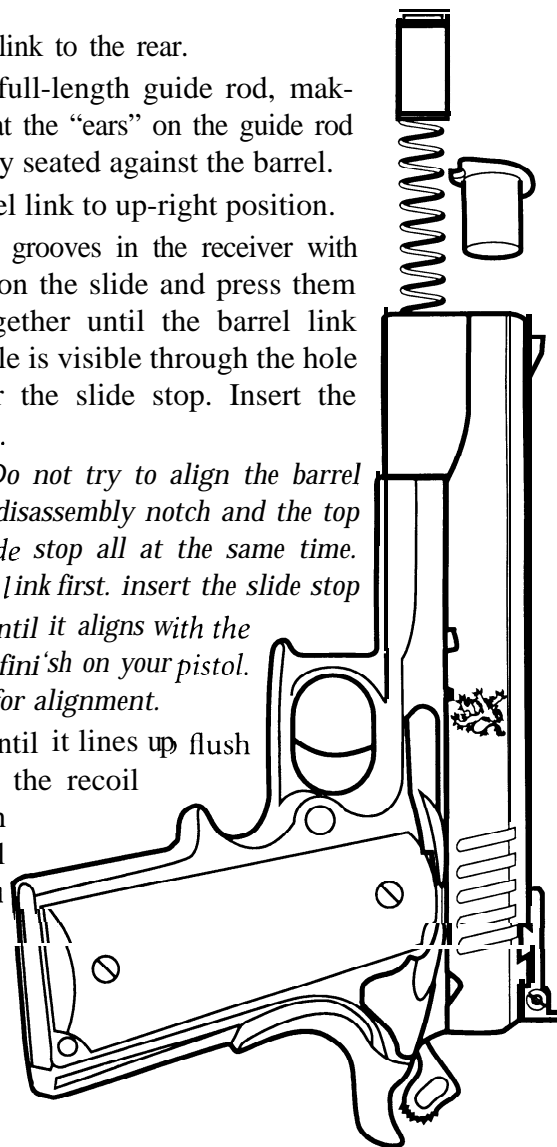

With the pistol braced firmly on a padded surface (a carpet scrap works nicely), compress the spring into the slide while holding the slide in place and keeping the barrel bushing ready. About this time you'll wish you had a third hand.

Use the base of a magazine or a barrel bushing wrench to compress the recoil spring cap flush with the slide and muzzle. *Keep the muzzle aimed away from your face - if the spring gets away from you it will shoot out with considerable force.*

Insert the barrel bushing and twist clockwise to lock it in place. The recoil spring cap should snap into the bushing notch.

Move the slide to the rear until the slide stop lines up with the slide stop notch. Then depress the slide stop and ease the slide forward into battery. Lower the hammer.

Your pistol is ready for loading.

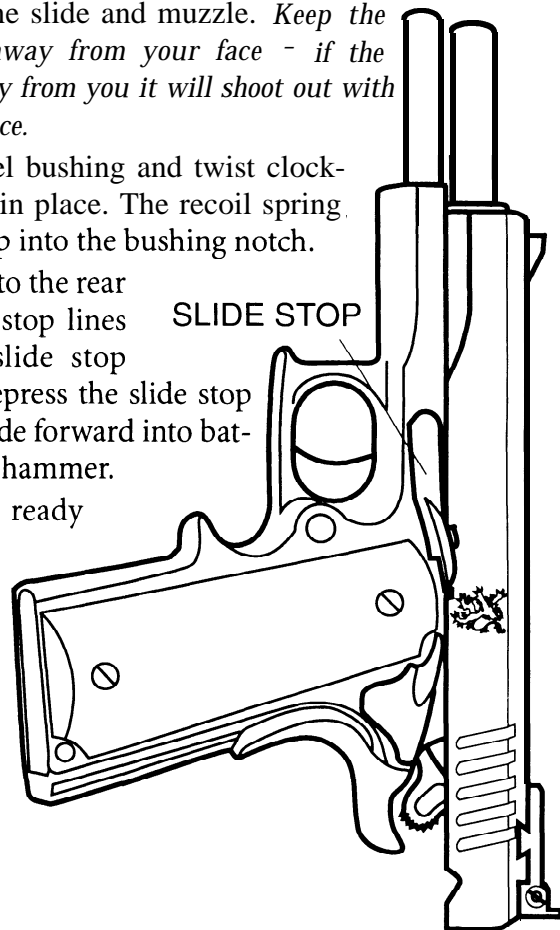
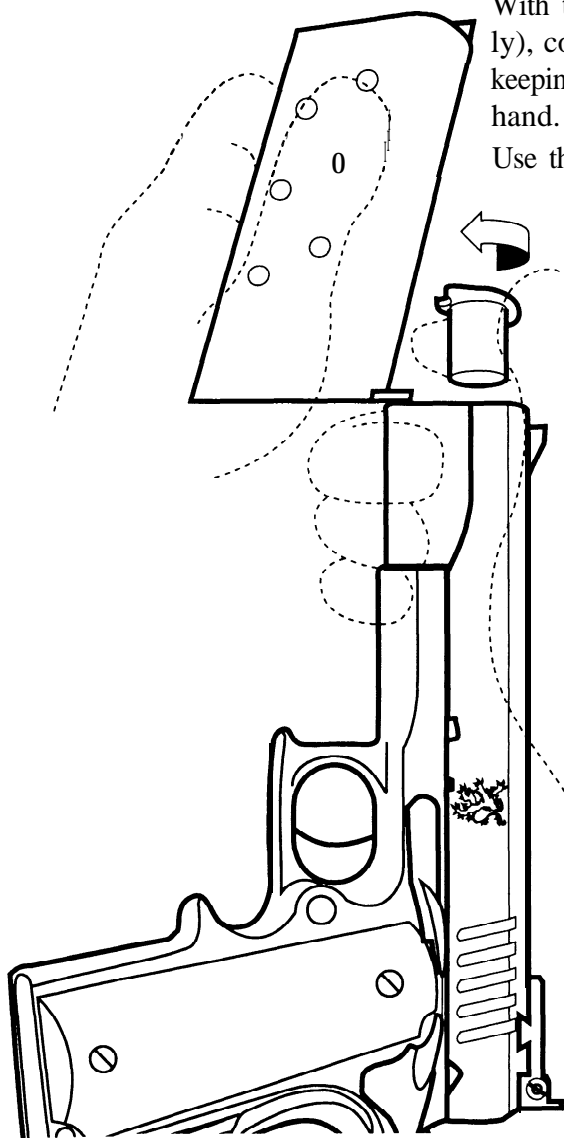

BIG DEUCE and 6" STAINLESS

Remove magazine and check to make sure pistol is unloaded.

Move the slide back a little until the takedown notch is just above the slide stop tab.

Remove the slide stop by pulling it straight out - it can be started by pressing on the end that protrudes from the opposite side of the frame.

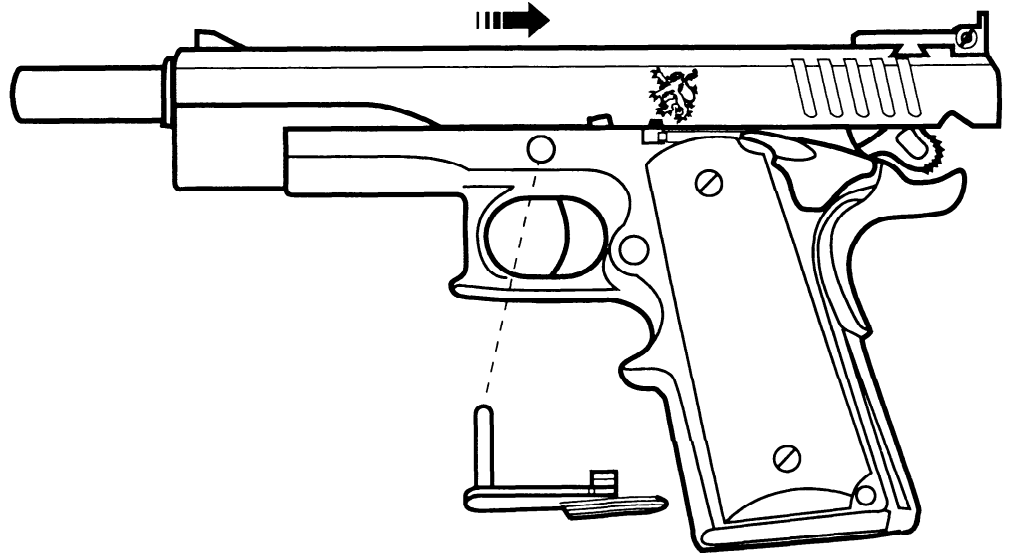

Ease the slide forward into battery. Then, while gripping the slide and receiver, move the slide forward off the receiver. Maintain your grip on the slide and its internal components (barrel and recoil unit) to keep them from springing apart.

Carefully slide the recoil spring out of its seat - be careful that it doesn't shoot out of your hand.

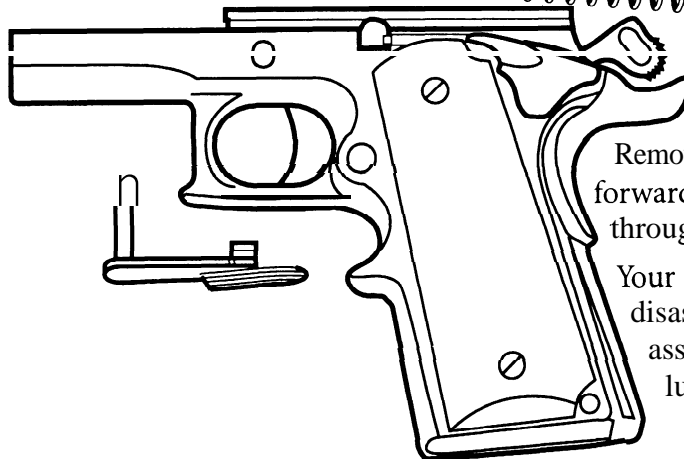
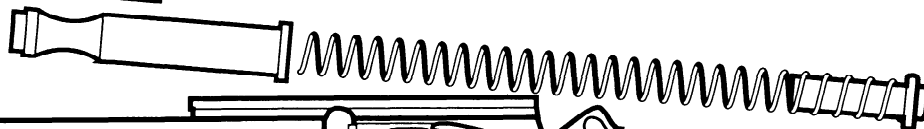
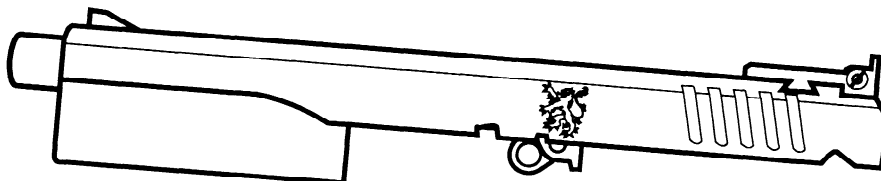
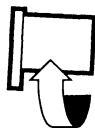
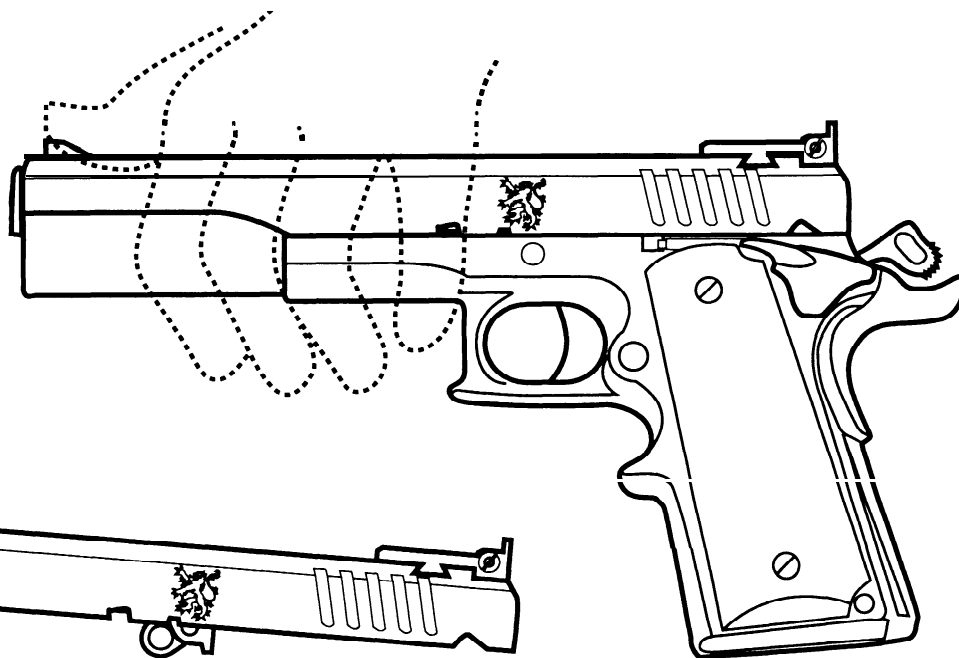

Then twist the barrel bushing counter-clockwise and remove.

Remove recoil spring cap. Flip the barrel link forward (toward muzzle) and remove barrel through the front of the slide.

Your **Big Deuce** or **6" Stainless .45** is now disassembled for cleaning - no further assembly is necessary or advisable. Clean, lubricate, and reassemble in reverse order.

Clean and lubricate using:

a stainless or polished steel cleaning rod (avoid using an aluminum or wooden rod - they can collect abrasive residue);

a brass bore brush which threads onto the cleaning rod;

a supply of patches (ready-made, or cut out of cotton or flannel rags) and several rags;

an old towel or carpet scrap for your working surface;

an old toothbrush or a brass-bristled parts brush; and

"CLP" or suitable gun oil.

Swab the bore (inside of the barrel) by pushing a dry patch through it with the cleaning rod, ***always entering from the rear***. The first pass will push out loose fouling. Then, using a clean patch dampened with "CLP", do the same thing again. **DO NOT** allow the rod to scrape the edges as it passes through the bore. If you damage the rifling, the pistol's accuracy will be affected.

Let the "CLP" work on the bore deposits while you use a rag dampened with more "CLP" and scrub and wipe off the inside of the slide (especially around the breech and the locking lugs - the lugs on the inside of the slide that match up to the indentations on the barrel), the outside of the barrel, and the slide stop.

Wipe off the black residue on the face of the breech around the firing pin hole and under the hook of the extractor. Wipe off any residue on the barrel bushing and recoil spring guide as well. Wipe off any excess oil.

After the "CLP" has had a chance to loosen the deposits in the bore, run a dry patch through the barrel, use a

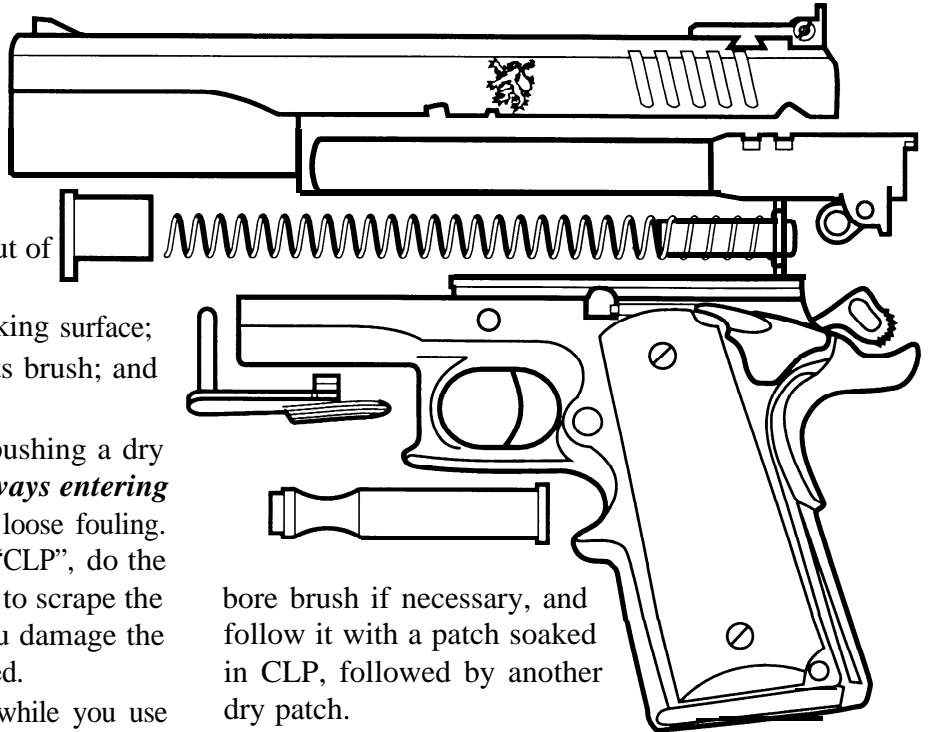

bore brush if necessary, and follow it with a patch soaked in CLP, followed by another dry patch.

With a quality lubricant designed for stainless steel (such as FP-10, Energy Release, etc.), put a few drops on the running, or friction, surfaces *in the slide only*; i.e., where the barrel rides, the slide rail surfaces where they match the frame and on the disconnecter ramp. These areas usually show wear and shiny patches. **NEVER** squirt oil into the frame.

Do not over-oil. It can be detrimental to the proper function of the pistol.

Big Deuce Reassembly

Turn slide upside down. Flip barrel link toward the muzzle and ease barrel into the slide until it seats on the locking lugs in the top of the slide.

Press in the barrel bushing and twist it clockwise to lock.

Flip barrel link to the rear.

Insert the recoil spring cap

Ease guide rod into recoil spring and feed it into the recoil spring cap as shown. The spring is very stiff under compression and will try to kink or get away from you. It is advisable to grip the slide and compressed spring with one hand while the other hand feeds in the remainder

Flip barrel link to up-right position.

Align the grooves in the receiver with the lugs on the slide and press them together until the barrel link hole is visible through

the hole for the slide stop. Insert the slide stop.

NOTE: Do not try to align the barrel link, the disassembly notch and the top of the slide stop all at the same time. Align the link first, insert the slide stop shaft, and then

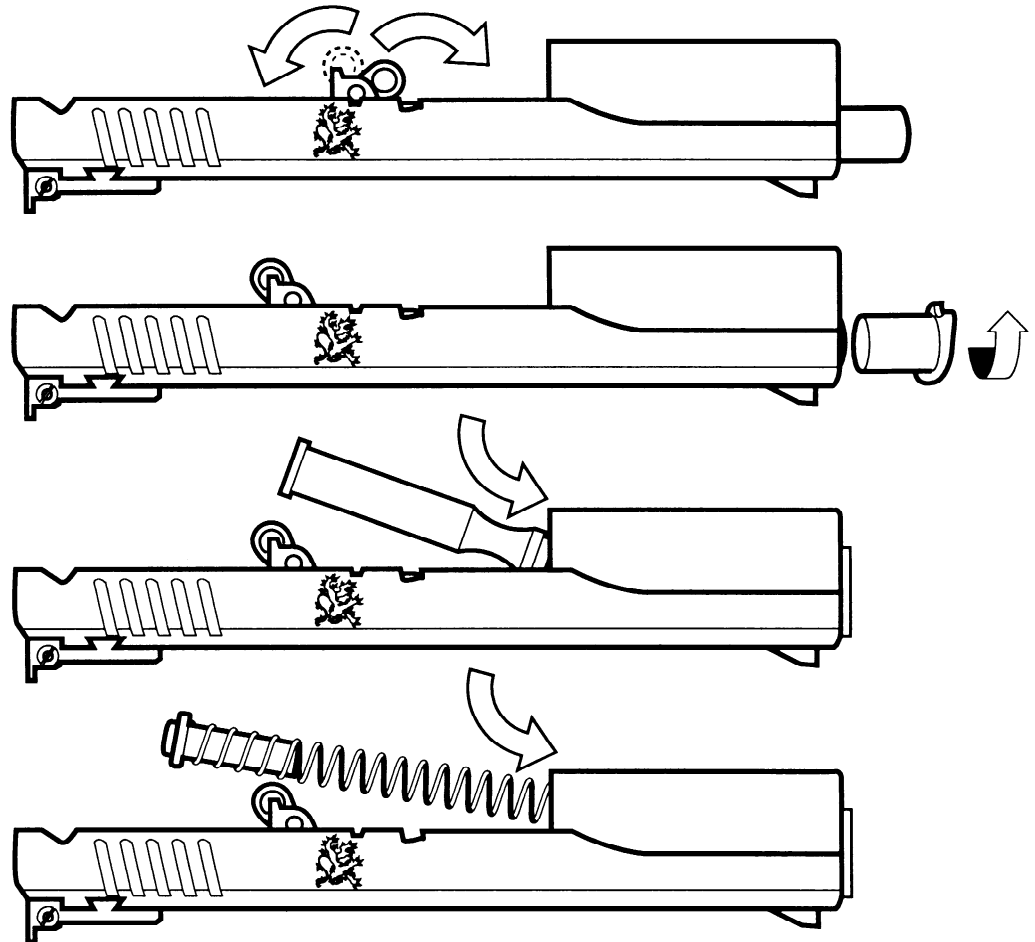

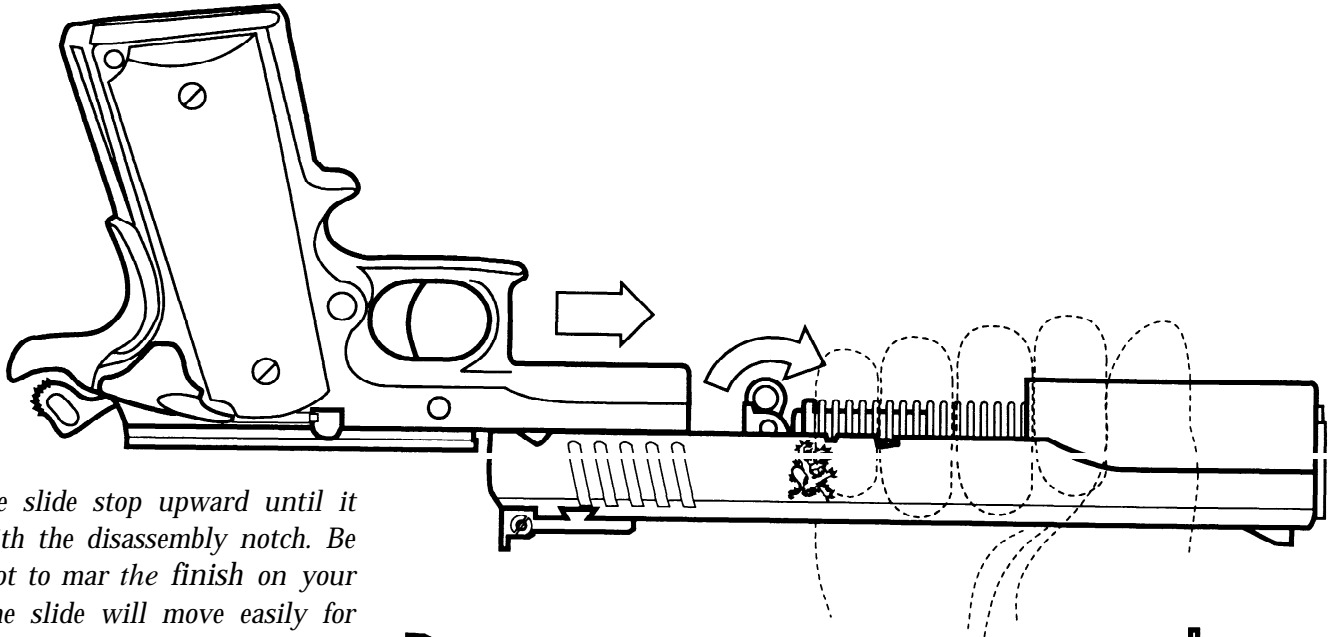

rotate the slide stop upward until it aligns with the disassembly notch. Be careful not to mar the finish on your pistol. The slide will move easily for alignment.

Move the slide to the rear until the slide stop lines up with the slide stop notch. Then depress the slide stop and ease the slide forward into battery. Lower the hammer.

Your pistol is ready for loading.

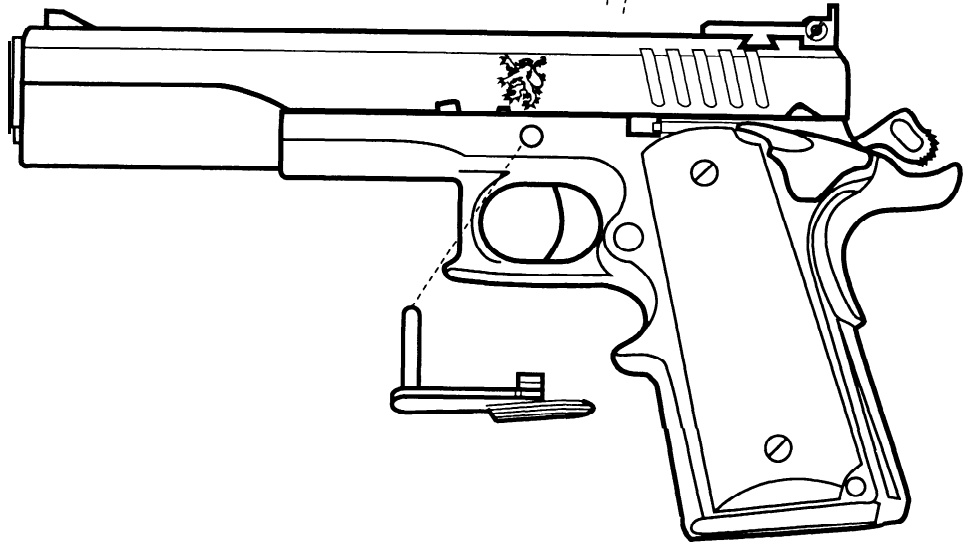

ENFORCER and COHORT

Remove magazine and check to make sure pistol is unloaded.

Move the slide back until disassembly notch is positioned over retaining tab on slide stop.

The slide stop can now be removed by pulling straight out.

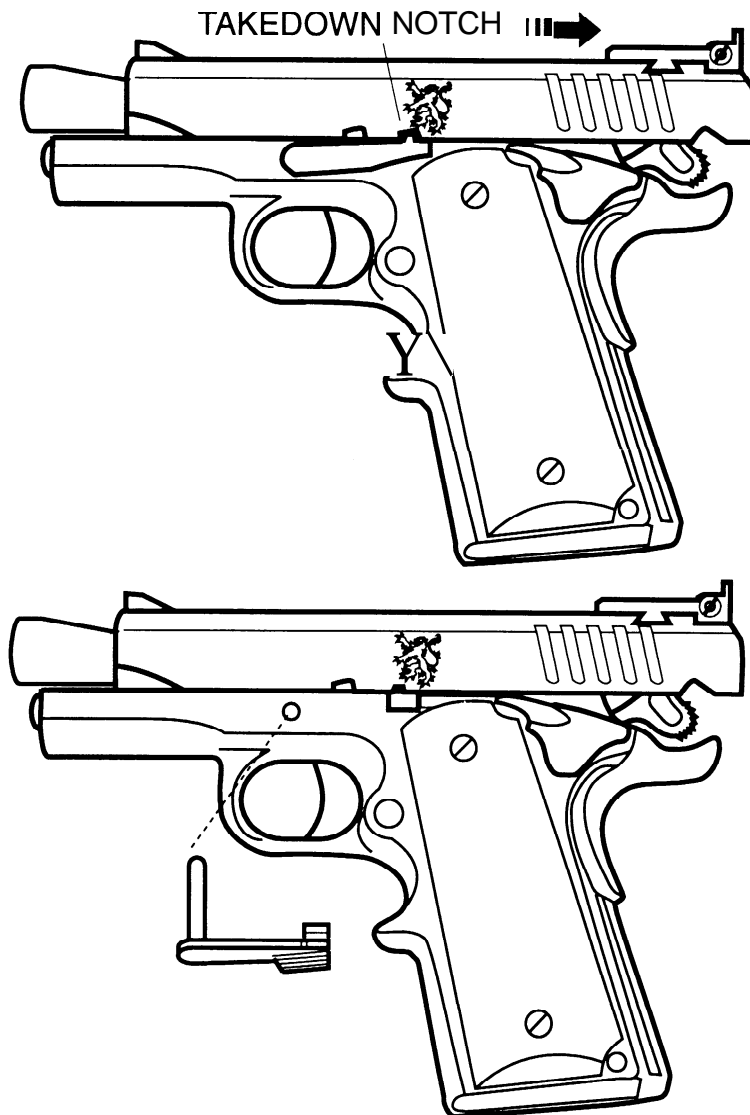

Remove slide unit by moving it forward and off the frame.

Remove the recoil system by pulling it back out of the recoil spring tunnel. (Flip the barrel link to the rear to make it easier).

DO NOT ATTEMPT TO DISASSEMBLE THE RECOIL SPRING ASSEMBLY.

The barrel can now be removed by flipping the barrel link forward and pulling the barrel out the front of the slide.

Reassembly is the reverse of the above order. During reassembly, the barrel link is put in the forward position to insert the barrel, then moved to the rear position to allow the recoil system to be seated. Be sure you can see the hole in the barrel link through the disassembly notch before inserting the slide stop.

Note: If guide rod protrudes from the pistol after assembly, the pistol is incorrectly assembled. Please try again

Your **Enforcer®** or **Cohort®** is now disassembled for cleaning no further disassembly is advisable.

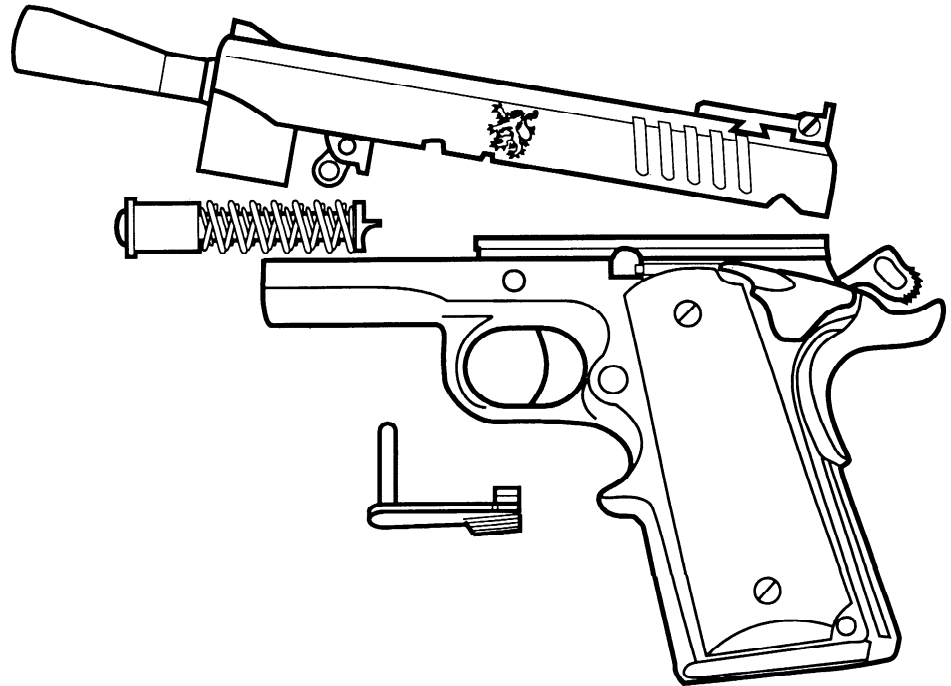

Clean and lubricate using:

a stainless or polished steel cleaning rod (avoid using an aluminum or wooden rod - they can collect abrasive residue);

a brass bore brush which threads onto the cleaning rod;

a supply of patches (ready-made, or cut out of cotton or flannel rags) and several rags;

an old towel or carpet scrap for your working surface;

an old toothbrush or a brass-bristled parts brush; and

“CLP” or suitable gun oil.

Swab the bore (inside of the barrel) by pushing a dry patch through it with the cleaning rod, ***always entering from the rear***. The first pass will push out loose fouling.

Then, using a clean patch dampened with “CLP”, do the same thing again. DO allow the rod to scrape the edges as it passes through the bore. If you damage the rifling, the pistol’s accuracy will be affected.

Let the “CLP” work on the bore deposits while you use a rag dampened with more “CLP” and scrub and wipe off the inside of the slide (especially around the breech and the locking lugs), the outside of the barrel, and the slide stop.

Wipe off the black residue on the face of the breech around the firing pin hole and under the hook of the extractor. Wipe off any residue on the barrel bushing and recoil spring guide as well. DO NOT ATTEMPT TO DISASSEMBLE RECOIL SPRING UNIT. This is a professionally-assembled triple-spring unit which is extremely tricky to put back together. Scrub it with a toothbrush with a little CLP on it. Wipe off any excess oil.

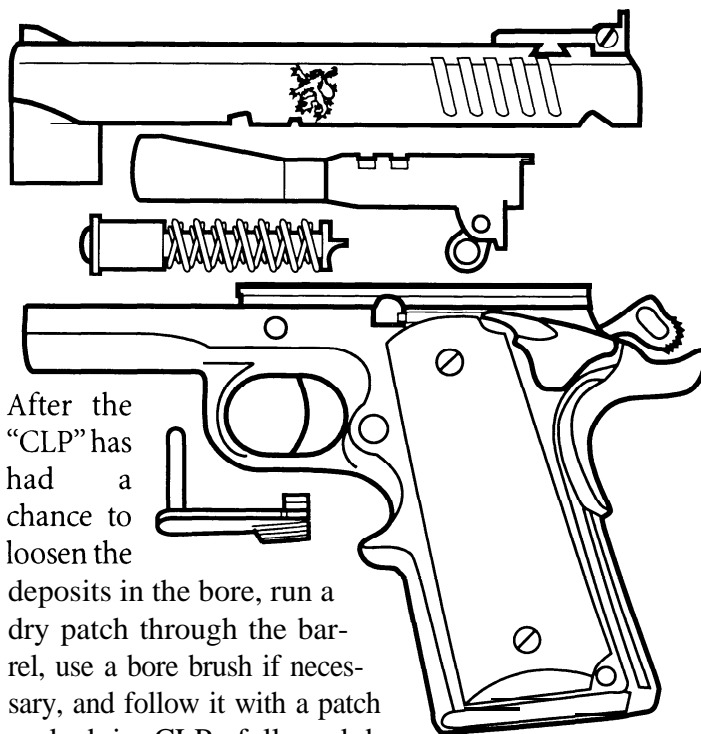

After the “CLP” has had a chance to loosen the deposits in the bore, run a dry patch through the barrel, use a bore brush if necessary, and follow it with a patch soaked in CLP, followed by another dry patch.

Use a quality lubricant designed for stainless steel (such as FP-10, Energy Release, etc.). Put a few drops on the running, or friction surfaces *in the slide only*; i.e., where the barrel rides, the slide rail surfaces where they match the frame, and on the disconnecter ramp. These areas usually show wear and shiny patches. NEVER squirt oil into the frame. Do not over-oil. It can be detrimental to the proper function of the pistol.

Enforcer and Cohort Reassembly

Turn slide upside down. Flip barrel link toward the muzzle and ease barrel into the slide until it seats on the locking lugs in the top of the slide.

Flip barrel link to the rear.

Insert the recoil spring system. **NOTE:** The triple-spring recoil system is not designed to be disassembled except by factory-trained experts. **Do not take this system apart.**

Flip barrel link to upright position.

Align the grooves in the receiver with the lugs on the slide and press them together until the barrel link hole is visible through the hole for the slide stop. Insert the slide stop.

NOTE: Do not try to align the barrel link, the disassembly notch and the top of the slide stop all at the same time. Align the link first, insert the slide stop shaft, and then rotate the slide stop upward until it aligns with the disassembly notch. Be careful not to mar the finish on your pistol. The slide will move easily for align-

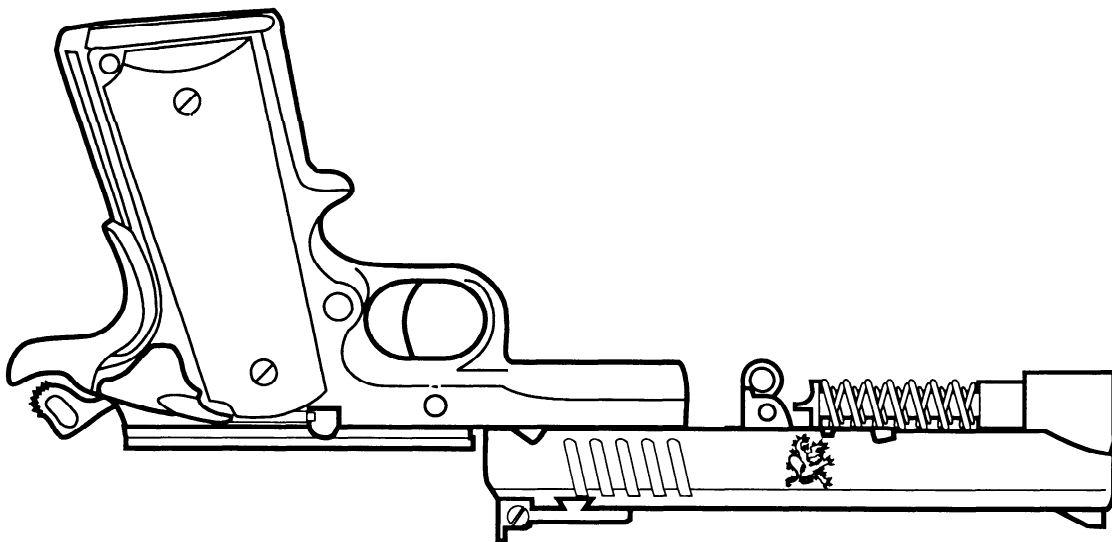
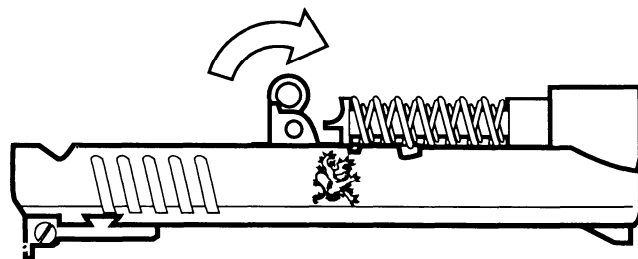
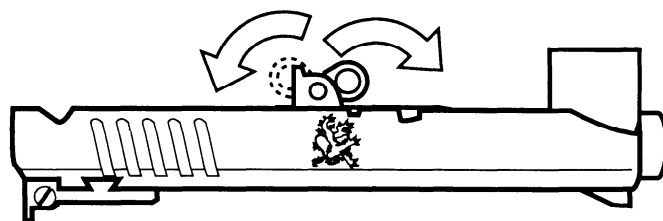

ment.

Move the slide to the rear until the slide stop lines up with the slide stop notch. Then depress the slide stop and ease the slide forward into battery. Lower the hammer.

Your Enforcer or Cohort is ready for loading.

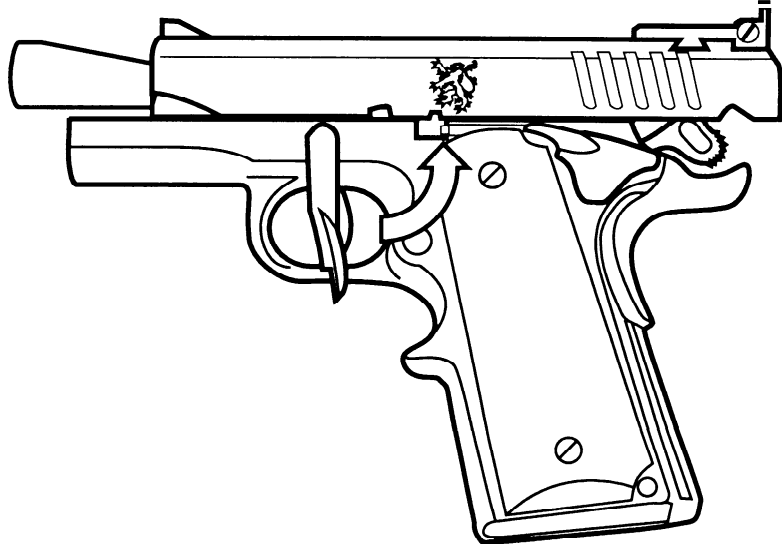
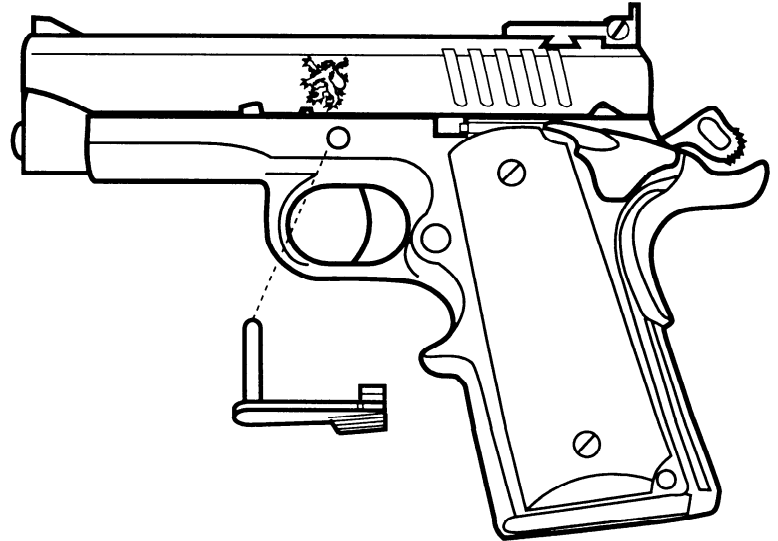

WARRANTY INFORMATION

This "Limited Warranty" has been drafted to comply with the Magnuson-Moss Warranty Federal Trade Commission Improvement Act which is effective for goods manufactured on or after December 31, 1995.

Safari Arms, Inc. firearms are warranted to be free from defects in material and workmanship for ten (10) years after the date of original new gun retail purchase. The manufacturer agrees to correct by repair or replacement (with the same or comparable quality model) your firearm, without charge, if returned prepaid with a copy of the bill of sale and a copy of ATF Form 4473.

Safari Arms, Inc. assumes no responsibility for product malfunction or for physical injury or property damage resulting in whole or in part from criminal or negligent use of the product, improper or careless handling, unauthorized modifications, use of defective, aluminum-cased, or hand-loaded ammunition, customer abuse or neglect of the product, or other influences beyond Safari Arms, Inc.'s control. This warranty does not apply to normal wear of any parts, including metal, wood, plastic, rubber and other material's surfaced finish or if unauthorized repair and/or alteration has been performed.

This warranty does not cover repairs related to unreasonable use, corrosion, failure to provide proper maintenance, damaged or shopworn display guns, gun barrels damaged by an obstructed bore or guns damaged in shipment due to improper packing and handling.

Safari Arms, Inc. reserves the right to inspect any product before making any adjustment covered by this warranty.

Under no circumstances shall Safari Arms, Inc. be liable for incidental or consequential damages with respect to economic loss or injury or property damage whether the result of breach of express or implied warranty.

Some states do not allow the exclusion of consequential or incidental damages so the limitation may not apply to you. This warranty gives only the original retail purchaser specific legal rights. Other rights may also be available which may vary from state to state.

The terms of the warranty cannot be changed except in writing by an officer of Safari Arms, Inc.

Some Tips from Your Pistolsmith

If you have questions or problems, call me first, before you do something you'll regret.

- NEVER "Hollywood" your pistol; that is, do not drop the slide on an empty chamber unless there is a loaded magazine in place. After clearing, ease the slide forward and dry fire the pistol. Dropping or slamming the slide on an empty pistol may seem cool, but it *will* damage your pistol.
- Dry firing - provided you follow all safety guidelines - does *not* hurt a 1911 pistol, but lowering the hammer into the half-cock can easily deform the sear nose we so carefully matched and stoned.
- Keep an idea of how many rounds have been through your pistol. Depending on what loads you shoot, a single recoil spring should be replaced after 2,000+ rounds

(this does not apply to the triplex spring system on the Cohort and Enforcer).

- Remember 95% of malfunctions in these pistols are due to ammo or magazines. Keep that in mind when you consider bargain "Baggie Brand" ammunition or "Three for \$20" magazines at the gun show or the discount gun shop. It is true: *You get what you pay for, if you're lucky.*
- Use both a quality powder solvent and a quality stainless steel lube. "Shooter's Choice" is the best powder solvent. "FP-10" is the best lube. Always buy *non-aerosol* lube: it is better to apply a few drops of lube in the right place than to spray-hose an entire area with aerosol.
- If in doubt, find out - call and talk to Safari Arms.