



Construction Plans for a Folding One-Man Kayak

Troop 303
Verdugo Hills Council
Iron Eyes Cody District
Boy Scouts of America

Received courtesy of Troop 37
Palo Alto Council
Boy Scouts of America

Revised September 25, 1995

Drawings by
Rob Kaspar

Text by
David J. Ellis

Revised by
Rob Kaspar, Alton Brown,
Bruce Wilton

Adapted from original plans and instructions by Jess Rathburn,
coordinator of Industrial Arts, San Francisco School District.

FOLDING ONE-MAN KAYAK **GENERAL INFORMATION**

This kayak weighs less than 40 pounds and will carry a full-sized man, It is constructed of plywood, canvas, and wood strips — all held together with contact cement and screws.

The design is for a 10 foot kayak, but 8, 12, and 14 foot versions have been successful.

The boys build the kayaks as a group, with adult supervision. Most of the materials needed for construction are purchased as a bulk order at the lowest price available. Paint and sandpaper are bought on an individual basis.

Most of the work is done during three one-day sessions.

At the first session the plywood is cut into the body panels, the spreader boards are cut and shaped, and all the remaining parts are cut out.

Between the first and second sessions the boy must complete sanding and painting the inside surfaces of the body panels, as they become inaccessible when the kayak is glued together.

The wood panels become a kayak on the second session when they are glued together with contact cement and canvas strips.

On the final session, all the reinforcing wood strips and boards are glued, screwed, and bolted into their proper place to complete the kayak. The seat is also finished.

All that remains is for the scout to paint the kayak with a scheme of his choice and to prepare for the thrill of paddling his own boat for the first time!

The final painting is done by the boy at home. About thirty boy (and parent) hours are needed to complete the kayak.

LIST OF MATERIALS
(All measurements in inches)

Body Panels	4 pcs.	1/4 x 11-7/8 x 120 (Plywood)
Floor Board	1 pc.	1/4 x 9 x 48 "
Back Rest	1 pc.	1/4 x 9 x 14 "
Spreader Boards	2 pcs.	1/2 x 11 x 24 "
Outer Cockpit Edging	2 pcs.	5/8 x 3/4 x 48 (Clear Pine
Inner Cockpit Edging	2 pcs.	5/8 x 3/4 x 48 or Fir)
Floor Strips	2 pcs.	1/2 x 3/4 x 48 "
Bottom Runners	2 pcs.	1/2 x 3/4 x 117 "
Canvas End Strips	2 pcs.	6 x 46
Canvas Side Strips	2 pcs.	6 x 96
Canvas Center Strip	1 pc.	12 x 198
Canvas Center Reinforcement	1 pc.	14 x 132
Canvas Cockpit Reinforcement	2 pc.	6 x 12
Back Rest Hinges	2 pcs.	2-1/2 x 4 (canvas scraps)
Contact Cement (glue)	4 qts.	
Brass Flat Head Mach. Screws	12	10-32 x 1-1/4
Brass Flat Head Mach. Screws	4	10-32 x 3/4
Brass Nuts	16	10-32
Fender Washers	16	3/16
Stop Blocks	12	1 x 2 x 2
Brass Wood Screws	12	#8 x 7/8
Paint/ Varnish	As required	
Latex Primer	As required	
Wood Putty	As required	
Lacquer Thinner	As required	

Notes Regarding Materials

Make sure the plywood is exterior grade.

Other wood parts such as floor strips, edgings and bottom runners can be made from either clear pine or fir.

MATERIAL REQUIREMENTS

PLYWOOD: AC-Exterior (good one side) is very adequate for the plywood parts. Marine plywood is too expensive and differs from AC-Ext. only in that it has no voids.

CANVAS: Usually sold by duck number (smaller number means heavier canvas) or by ounces per yard. Canvas from 10 to 88 oz/yard has been used satisfactorily. In duck canvas, a number 10 duck is economical, while a number 4 duck will give maximum durability. We have obtained canvas from awning companies in the past. It is most easily cut on a board with a razor blade or very sharp knife. Canvas should be untreated.

CONTACT CEMENT: GRIP BRAND has been used for the past few years. Its green color may be undesirable if a clear varnish finish on the kayak is wanted. Other brands such as Weldwood have also been used in the past. Whatever brand you choose, make sure that it's waterproof, and not merely "water resistant". (No ifs, ands, or buts here) It would be embarrassing for your boat to fall apart on the water! Also, don't use a foam brush because the solvent in the contact cement will destroy the brush.

PAINT: Any exterior paint or varnish will do. Be sure to give wood one coat of latex primer before applying the finish coats. A flexible paint should be used on the canvas, as it is subjected to folding. (An exterior latex paint works well here.) Some paint solvents may soften contact cement and cause the canvas to peel off. A latex primer coat will guard against this. The two most common painting schemes have been:

1. All surfaces (i.e.. wood and canvas) painted with one coat of latex primer followed by an exterior latex paint. Contrasting colors can be used.
2. Canvas painted with a flexible-exterior latex and wood painted with a hard durable paint such as Varathane.

Both paint jobs eventually get scratched up on the rocks and may need refinishing.

TOOLS AND SUPPLIES

Power tools greatly speed construction, and will be used only under careful adult supervision. If you have one or more of the power tools listed, please bring them to the work sessions indicated. Hand tools and supplies should be brought to the indicated sessions. Tools marked with an asterisk (*) can be pooled or will be provided.

<u>Power Tools</u>	<u>Sessions needed</u>
* Table Saw - for cutting plywood sheets	1st
* Skil Saw - for cutting plywood sheets	1st
* Saber Saw - for curved cuts	1st & 3rd
* Router - for rounding edges of spreader boards	1st
* Belt Sander - for smoothing rough edges	1st & 3rd
* Power Drill - for drilling screw holes, etc.	1st & 3rd
<u>Hand Tools & Supplies</u>	<u>Sessions needed</u>
Pencil	1,2,3
Tape Measure, Ruler	1, 2, 3
C-Clamps	1, 2, 3
Work Gloves	1,2,3
Saw Horses or Benches	1, 2, 3
Cheap 1-2' Paint Brush (for glue)	2, 3
* Hard Roller (plastic)	2
Jar or Coffee Can with Lid (for glue)	2, 3
Newspapers	2, 3
* Screwdriver, Crescent Wrench	2, 3
Rags (to clean hands, etc.)	2, 3
Drill bit 5/16"	3
Countersink Bit	3
Sandpaper	1, home

FIRST SESSION - WOOD CUTTING

I. Cutting of Body Panels from 4' x 10' plywood. (Figure 1)

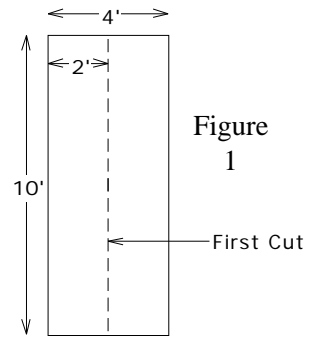

A. Cut 4' x 10' sheet down the middle to make two 2' x 10' sections. One will be for the bottom panels, the other for the top panels.

B. Mark the cut-out lines for the cockpit on one of the 2' x 10' sections. (Figure 1). The inner 10" x 36" cut-out piece is destined to become the floor board. A small hole is drilled on the midline and used to start the cut-out with a saber saw.

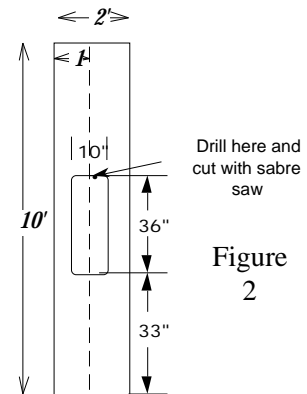

C. Both the top and bottom 2' x 10' sheets are now cut exactly in half. (Figure 3)

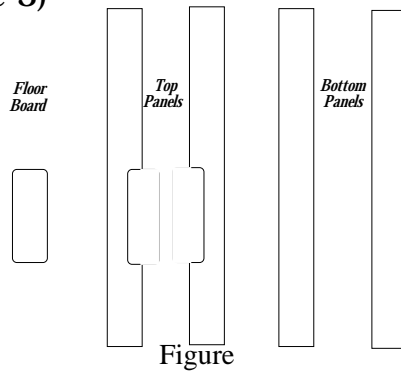

D. All 4 panels are clamped together and the corner curves are marked and cut out simultaneously (and identically) with a saber saw. The design for the bow and stern curves is left to the artistic taste of the Scout. Make sure you leave 1-1/2" on the ends for gluing later. (See Figure 4)

(Make sure to arrange it so the good sides of the plywood are out)

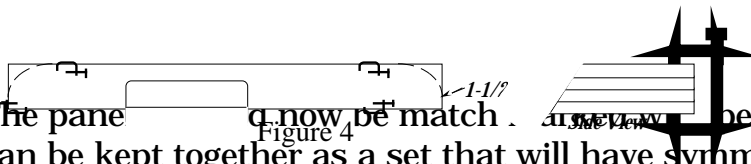
- E. The panels now be match .  pencil so they can be kept together as a set that will have symmetrical bow and stern curves. Pay attention to the plywood surface. The best side should be on the outside of the kayak. (see Figure 5)

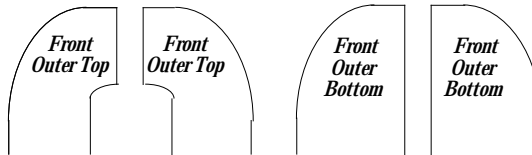

- F. Use a sander to smooth the rough edges

Cutting of Spreader Boards

- A. One or more 1/2" x 4' x 8' sheets of plywood are cut into as many 11" x 24" rectangles as needed. (2 spreader boards per kayak)

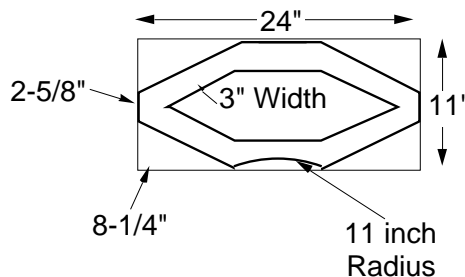

Figure 6

- B. Using the dimensions of Figure 6, lay out the cutting lines for the 11" x 24" rectangle.
- C. Drill a small hole for the center cut-out to aid in starting the saber saw blade, and complete cutting out center hole in spreader board.
- D. The corners are cut off with a skill saw or saber saw.
- E. Cut the final bottom radius with a saber saw,
- F. A power router can be used to round off all inside and outside edges of the final spreader board.

Cutting of Back Rest

- A. A 1/4" sheet of plywood is cut into the required number of 9" x 14" back rests. (About one-half sheet will make 18 pieces. One required for each kayak.)

Panel Strips

- A. The narrow strips used for reinforcement and protection of the bottom of the kayak will be pre-cut. If necessary, they must be ripped on a table saw to the necessary dimensions from 1" lumber.

Canvas Cutting

If time permits, cut out the canvas in accordance with Figure 10. Remember that the canvas will cut better if you put the first coat of contact cement on the canvas.

BETWEEN FIRST AND SECOND SESSIONS

SANDING AND PAINTING OF BODY PANELS

After the body panels have been cut out, they must be sanded and painted on the surfaces that will become the inside of the kayak. The rough side with the knot holes is generally put inside. The knot holes can be patched with wood putty, if desired.

After the edges and both sides of the panels are patched and sanded, the inner surfaces must be painted before the next group session. The edges can also be painted, but take care not to get paint on the outside as that will weaken the glue bond between the outer surface and the canvas. (See Figure 7)

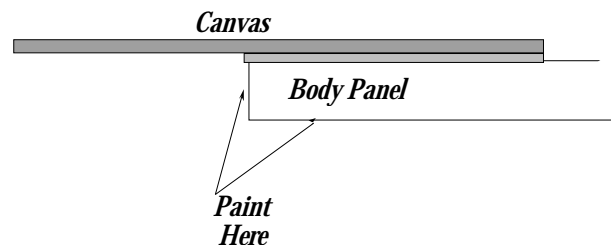

Figure 7

Also, you will need to make (or borrow) a pair of spacer blocks (not shown

on the materials list) before the second session. They are used to hold the four body panels together so that the canvas side strips can be applied along the edges. The blocks can be made from scraps of wood, etc. The dimensions of the center (3-1/2" x 3-1/2") block are critical, and it should be exactly square, and about 1/2" thick. (Figure 8)

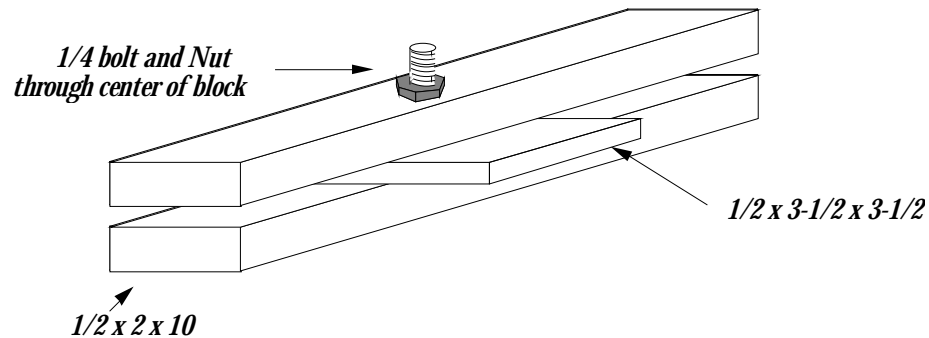

Figure 8
Spacer Block - make 2

SECOND SESSION - CANVAS GLUING

Bring the following items to the second session

1. Body panels (painted inside only)
2. Canvas strips
3. Floor board and back rest board
4. Spreader boards
5. A pair of spacer blocks
6. Stack of newspapers (3") (or a roll of butcher paper)
7. A cheap paint brush
8. A pair of saw horses or benches
9. Roller
10. Pencil
11. Tape Measure
12. Cheap Clothes- Contact cement doesn't come out!

The general procedure is to glue the canvas end strips first, then the canvas side strips, and finally the canvas center strip. The entire

procedure takes most of the day, as the glue must mostly dry between coats. (Each surface needs 2 coats of glue.)

It is recommended that the first coat of glue be put on the canvas **before** it is cut out to prevent fraying.

GENERAL GLUING INSTRUCTIONS

- a. Use cheap 1-2" brushes, as they are difficult to clean and are thrown away.
- b. Lacquer thinner or Methyl Ethyl Ketone (MEK) can be used to thin contact cement, and to clean it off hands, etc.
- c. Follow instructions on can. Avoid gluing in cold or damp weather. Work with good ventilation (outside) as the cement solvent is rather noxious.
- d. **FIRST COAT** Apply a thin "sealer" coat to both surfaces to be joined. Allow at least 30 min. before applying second coat.
- e. **SECOND COAT** Apply glue to both surfaces and let dry. When the cement is dry (at least 30 min.) contact may be made. The surfaces should be joined within 4 hrs. of applying the second coat.
- f. **MAKING CONTACT** Once the glue surfaces "grab" each other, they can not be shifted or moved - so line up pieces carefully before making contact. When gluing canvas to wood, rub the joint firmly with a block of wood or the back of a C-clamp or a roller to remove small wrinkles and to "set" the joint.

GLUING KAYAK TOGETHER

1. Clamp the four body panels together with the spacer blocks (painted surfaces inside, curves matched). (see Figure 9)

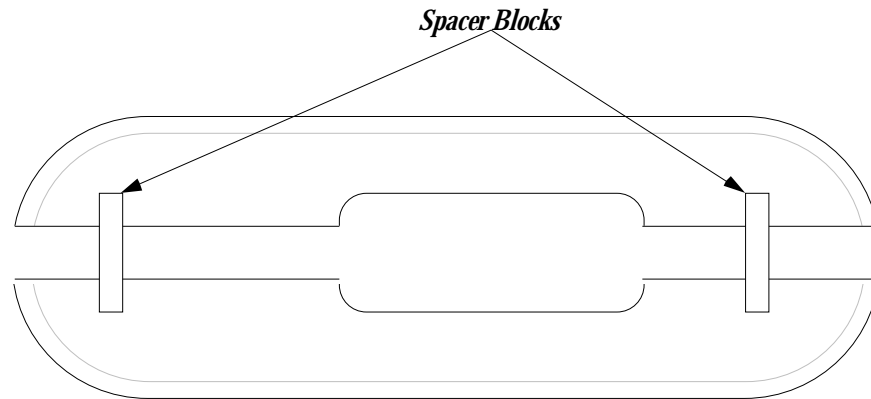

Figure 9

2. Draw a 2" margin around the entire boat, top and bottom to serve as a guide for applying glue. It's easiest to put the panels on a sawhorse from here on to save your back.
3. Apply the first thin coat of glue to the top panels covering the 2" margin. As soon as it is dry to the touch, turn over and apply likewise to bottom panels. Make sure to put glue on the edges also.
4. Lay out a row of newspapers about 16 feet long for gluing the canvas. Lay out the two end strips, the two side strips and the center strip of the canvas, in accordance with the dimension shown. (see figure 10)
5. Apply a thin first "sealer" coat of glue to the end and side strips prior to cutting.

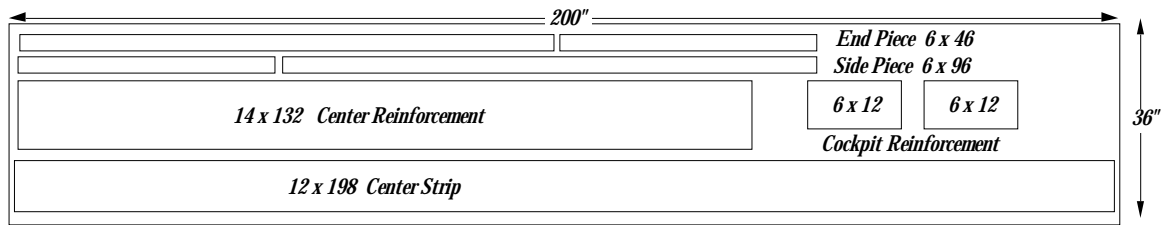

Figure 10

6. Apply second coat of glue to top and bottom panels.
7. Cut out the end and side canvas strips and apply second coat of glue.
8. While glue is drying on side and end strips, lay out glue margins on center strip. Mark center of strip. Make a similar mark on the boat so the strip will go COMPLETELY around the length of the boat from front cockpit edge, around the bottom of the boat and to the front cockpit edge. The first coat can then be applied to the center strip.
9. When the second coat of glue is dry on the panels, side, and end strips, you are ready to put the kayak together. Work in groups of 3 for this step. Two workers stretch the side strip apart, while the third worker carefully applies the center of the strip to kayak edge taking care to keep the strip even, and to avoid wrinkles.

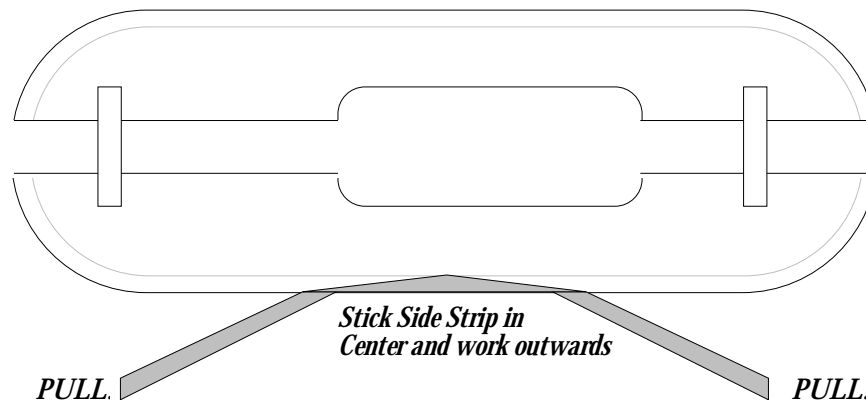

Figure 11

- Put on the second side strip, Work out wrinkles and “set” the joint with a small block, etc. Now apply a coat of contact cement to the last 5” of the side strips, where the end strips will overlap. (see Figure 12)

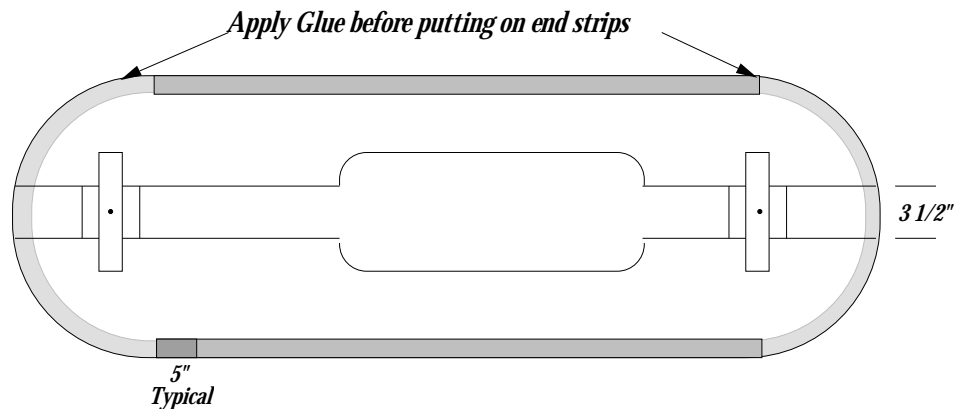

Figure 12

- When the glue is dry, apply the end strips, taking care that they are even and wrinkle free. Finally, the entire margin should be rolled firmly to set the joints.
- Now remove the spacer blocks and get ready for gluing the center strip. Use a pencil to mark glue margin on the top and bottom panels 5" from the center edge in line with the front edge of the cockpit. (See Figure 14) Mark the center of the bottom panel.

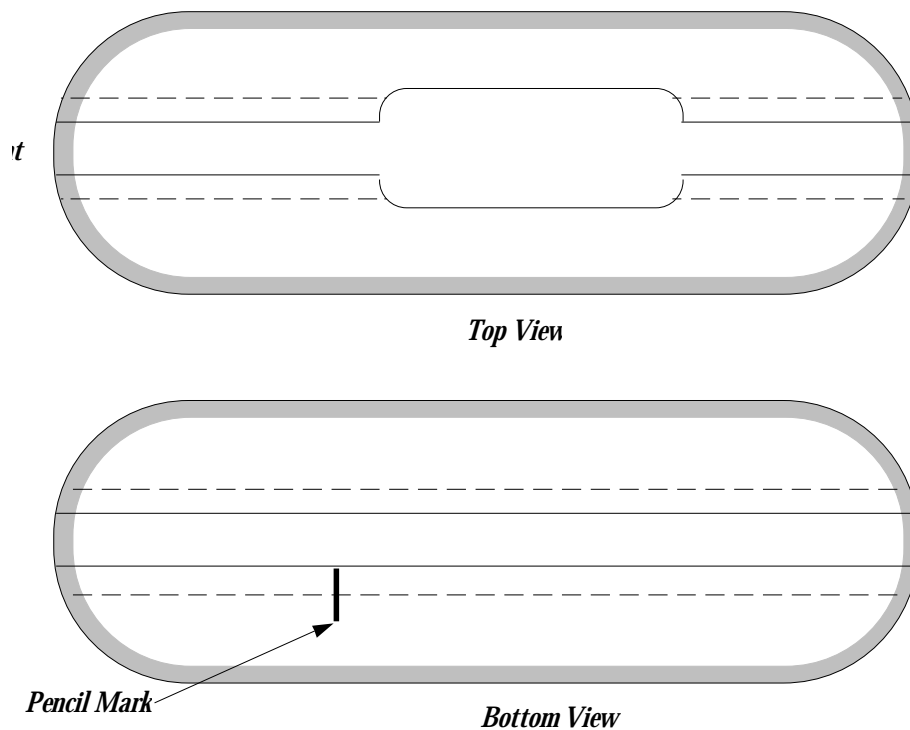
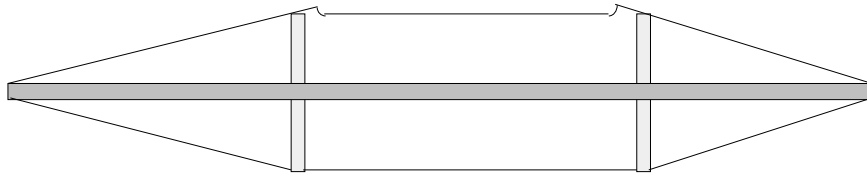

Figure 14

13. Apply first and second coats of glue to center margins of body panels and end canvas. Put glue on the inside of cockpit as canvas will overlap about 5 inches to the inside of the cockpit on each side.
14. Apply first and second coats of glue to center canvas strips in the same manner as the edge strips were coated. Remember to apply a thin first coat prior to cutting out the canvas strip.
15. When the second coat of glue is dry on the center strip and panels, the spreader boards can be put in to open the body-panels to their approximate normal position. Place the kayak upside down on saw horses. Remember to make sure the maximum gap between the boards with the spreader

boards inserted is 9 inches. See Figure 15



Side View

Figure 15

16. Three workers will be needed to put on the center strip. Two people hold the center strip above the kayak, while the third worker carefully aligns the center of the canvas strip (marked with pencil) to the mark on the kayak bottom (also marked with pencil). (See Figure 14) He then carefully works towards each end, taking care that the canvas is centered equally on each side, and wrinkle free. Turn the kayak over; continue to press the canvas to the top deck, finally folding the last 3-4" under at the cockpit. Use a block to set the joints and rub out any wrinkles. The spreader boards can now be removed and the joints lightly rolled with the roller.

THIRD SESSION - ATTACHING REINFORCING STRIPS

Bring the following items to the third session

1. Kayak
2. Wood for edgings, floor strips, and bottom runners
4. Contact Cement & Brush
5. Sand Paper, Sanding Block, etc.
6. Screwdriver, Wrench
7. C-clamps
8. Saw horses and Benches
9. Power Drill and Bits
10. Pencil and Tape measure
11. Rags for clean-up

Four pair of reinforcing strips will be installed, one on each body panel surface. They are, from top to bottom

1. Outer Cockpit Edging
2. Inner Cockpit Edging
3. Floor Strips
4. Bottom Runners

They will be glued on with contact cement, and the ends will additionally be bolted on to prevent loosening. (See Figure 16 & 17)

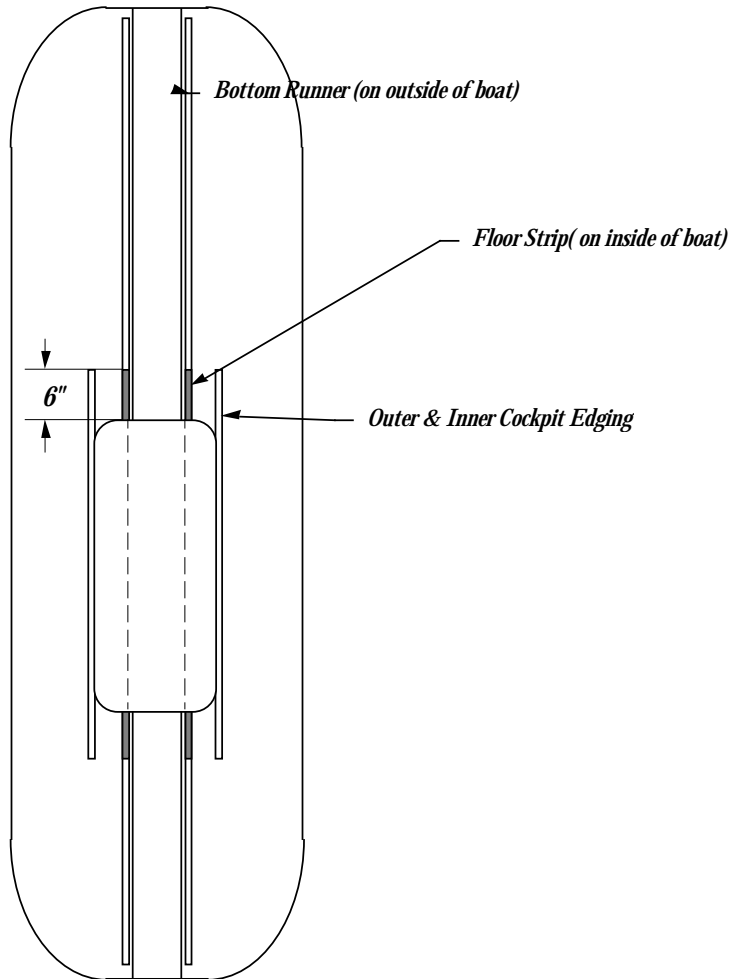
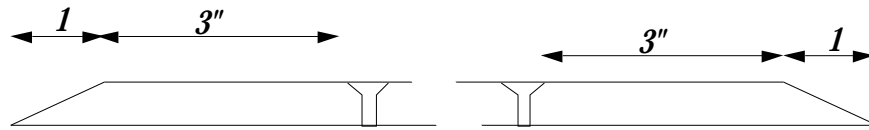

Figure 16



Side View

Figure 17

I. BOTTOM RUNNERS

- a. Taper the ends of the runners with belt sander and/or sandpaper as shown in Figure 17.
- b. Drill 3/16 holes 3 inches from each end of the runners, being careful not to drill through the top body panel. Counter sink all the drill holes so that a flat head 10-32 machine screw or nut will be flush with the runner.
- c. Apply two coats of glue to runners and the corresponding location on the bottom of the boat. The runners go on top of canvas just over the inside edge of the plywood panels (see figure 18).
- d. With kayak collapsed, put the runners in place. The ends should be 1-1/2" from the end of the kayak. Keep the runners close to the inside edge of the plywood.

Figure18

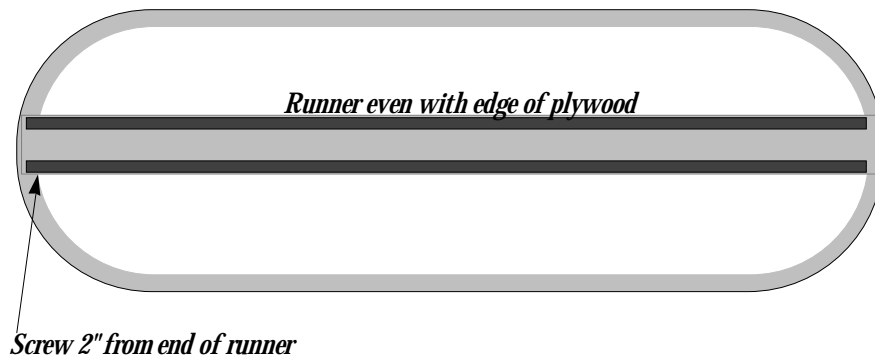

- e. Reinstall the spreader boards.
- f. Drill again into the 3/16 holes to extend the hole through the panel, being careful NOT to drill through the top panel.
- g. Put the 10-32 x 3/4" machine screws through the holes, reach inside the kayak (a good job for small boys), and put the nuts on all 4 screws; tighten.

II. FLOOR STRIPS

- a. Taper the ends of the strips with sandpaper the same as was done on the bottom runners and pre-drill as was done for the bottom runners.
- b. Mark the center of the strips and the center of the kayak with pencil.
- c. Mark glue margins on the inside of the kayak floor.
- d. Apply two coats of glue to the strips and the kayak floor.
- e. When the glue is dry, place the strips on the floor of the kayak - they should be even with the edges of the plywood pane and exactly opposite the bottom runners. (See Figure

16)

- f. Drill 13/64 holes 2 inches from each end, countersink and bolt into place with 10/32 machine screws.

III. COCKPIT EDGING

- a. Taper inner and outer strips with sandpaper.
- b. Pre-drill cockpit edgings in left and right pairs, so as to align the holes. Countersink as shown in Figure 19.
- c. Mark glue margins with pencil.
- d. Apply two coats of glue to the strips and the cockpit inner and outer edges.
- e. Place the inner and outer strips, and bolt into place with 10-32 screws and clamp with C-clamps. The bolts should be ground flush after the glue dries.

IV. STOP BLOCKS

- a. The eight stop blocks are designed to butt up against the back of the spreader boards, and to prevent them from being pushed inward (by a boy's foot - thus collapsing the kayak - usually in midstream)
- b. Mark the eight locations for the stop blocks on the inside of the kayak with pencil according drawing in back.
- c. Apply two coats of contact cement to the blocks and the corresponding spots inside the kayak.
- d. Carefully push the blocks into place.
- e. A small 3/8" flat head brass wood screw can be put into each block to give added strength.

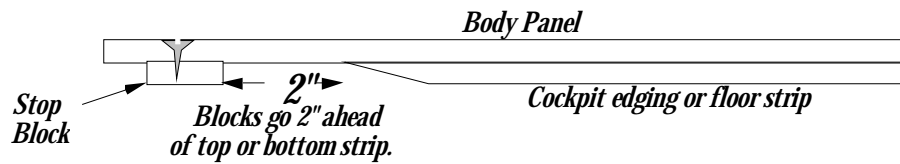
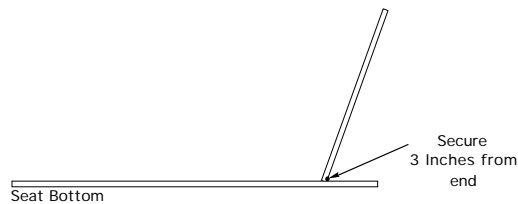

Figure 19

BUILDING AND PLACING THE SEAT

- a. Take the seat bottom (formerly known as the cockpit cutout) and the seat back which you cut out and glue the two together with the joint 3 inches from the back edge of the seat bottom. (see diagram) You may use canvas and contact cement for the hinge, but I have used a piano hinge for a longer lasting assembly.



- b. Place the seat in the boat so it is centered between the floor strips and so the seat backs make a comfortable angle (20 degrees off vertical).
- c. Secure 4 stop blocks by gluing and securing with screws, 1 block in the front of the seat, 1 block on either side of the seat bottom, and 1 in the rear.
- d. To store the seat when the boat is folded, remove it from between the blocks, fold the seat flat, and store it inside one side of the boat before folding.

Options

SKEGS

Attach Boogie Board fins to the bottom of the boat in the rear using wood or metal channels so that the fins are removable for storage. The fins make the boat track more naturally in a straight line.

THE WEDGE

Make a 12 inch by 12 inch seat wedge and elevate the front of it by 2 inches. Place this on the seat board along with a cushion and the seat is **MUCH** more comfortable for long trips.

THE RING

A 3 inch ring (purchased at a marine hardware store) may be attached to the front of the kayak. Tie 10 feet of nylon rope to the ring, making sure both ends of the rope are whipped. This rope will allow you to easily tie the boat to shore for breaks and will aid if a tow is needed.

Conclusion

This boat has been in scouting since the 1930's. As near as I can tell, it has been on rivers all over the United States, and who knows, a large part of the world.

If you are going to build one of these boats, good luck and have fun. But remember, your success in building and then using this boat is a combination of planning, care, and knowledge.

Get out there and have many adventures!!

Author's Note to Scout Leaders:

I have helped build more than 30 of these boats over the years and each one is still floating. My own personal boat was made out of a 12 foot sheet of plywood and was made a little wider.

The stability of these boats is incredible. I have performed a rescue of a 17 foot canoe with my kayak. I can also carry enough gear for a 4 day trip with no problems. If your scouts are going to get into trouble, it will be during the gluing phase. Make sure there is enough canvas glued to the boat for safety. If questions come up, my E-mail address is 73443.3651@compuserve.com. Drop me a line and we will figure it out.

Best regards and safe sailing!!!

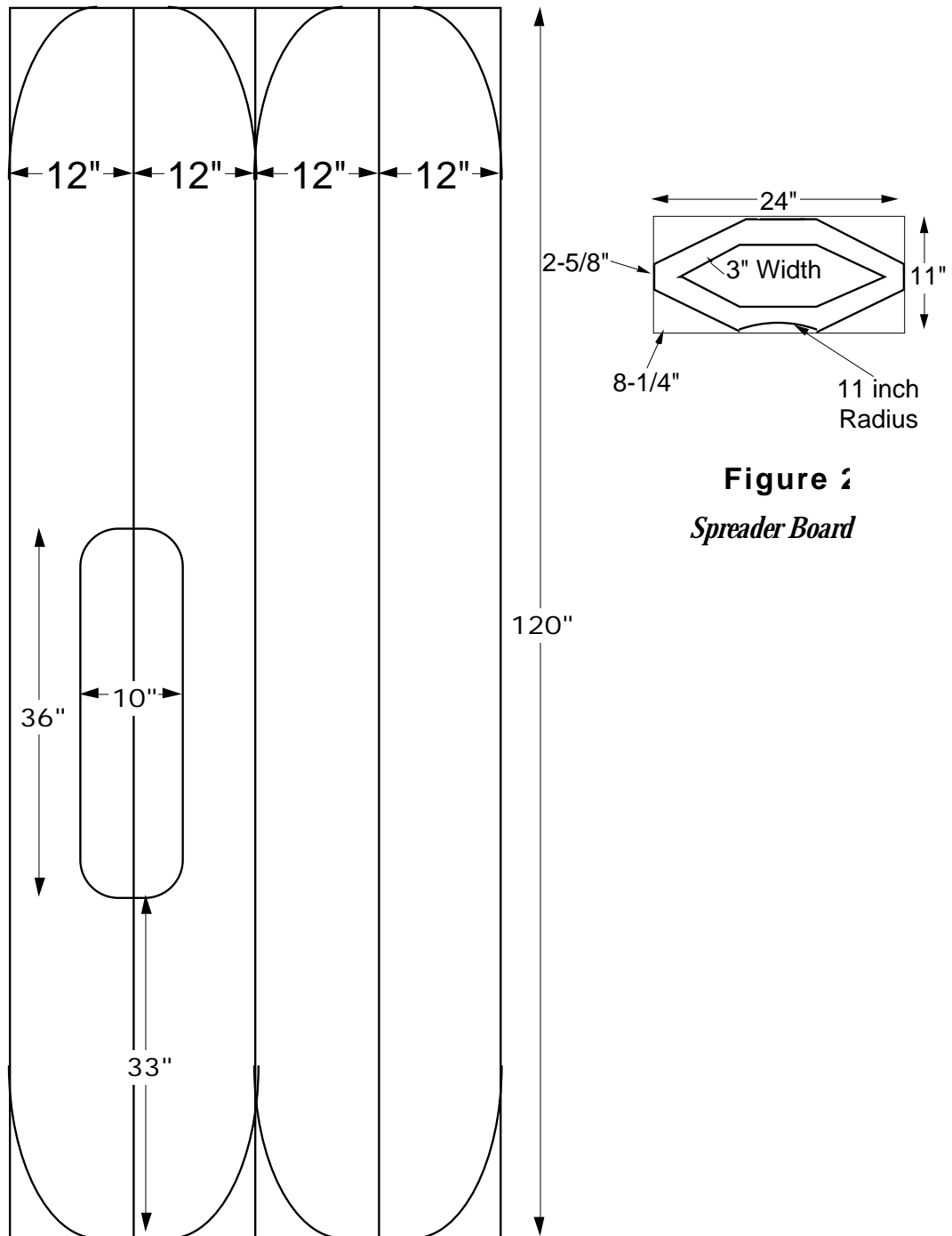
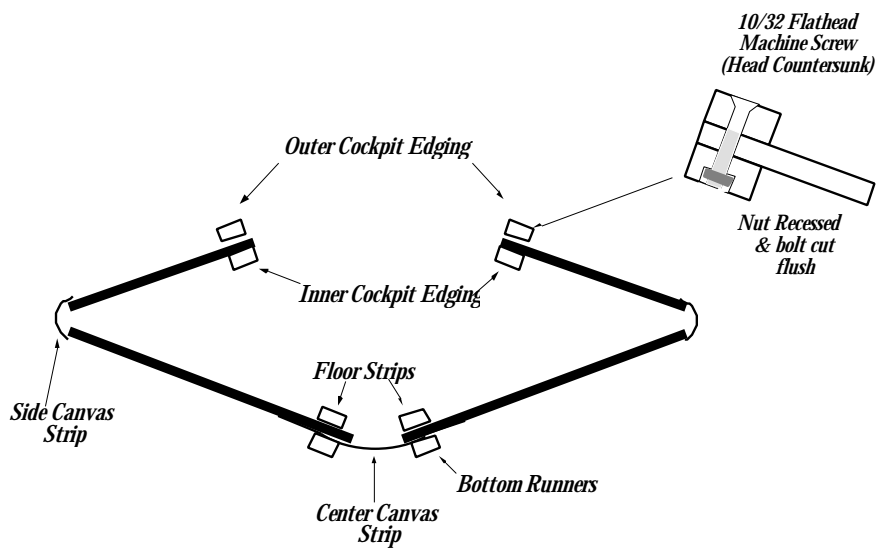

Figure 1.

Figure 2
Spreader Board



Cross Section-Midship

Figure 7

See placement detail on next page

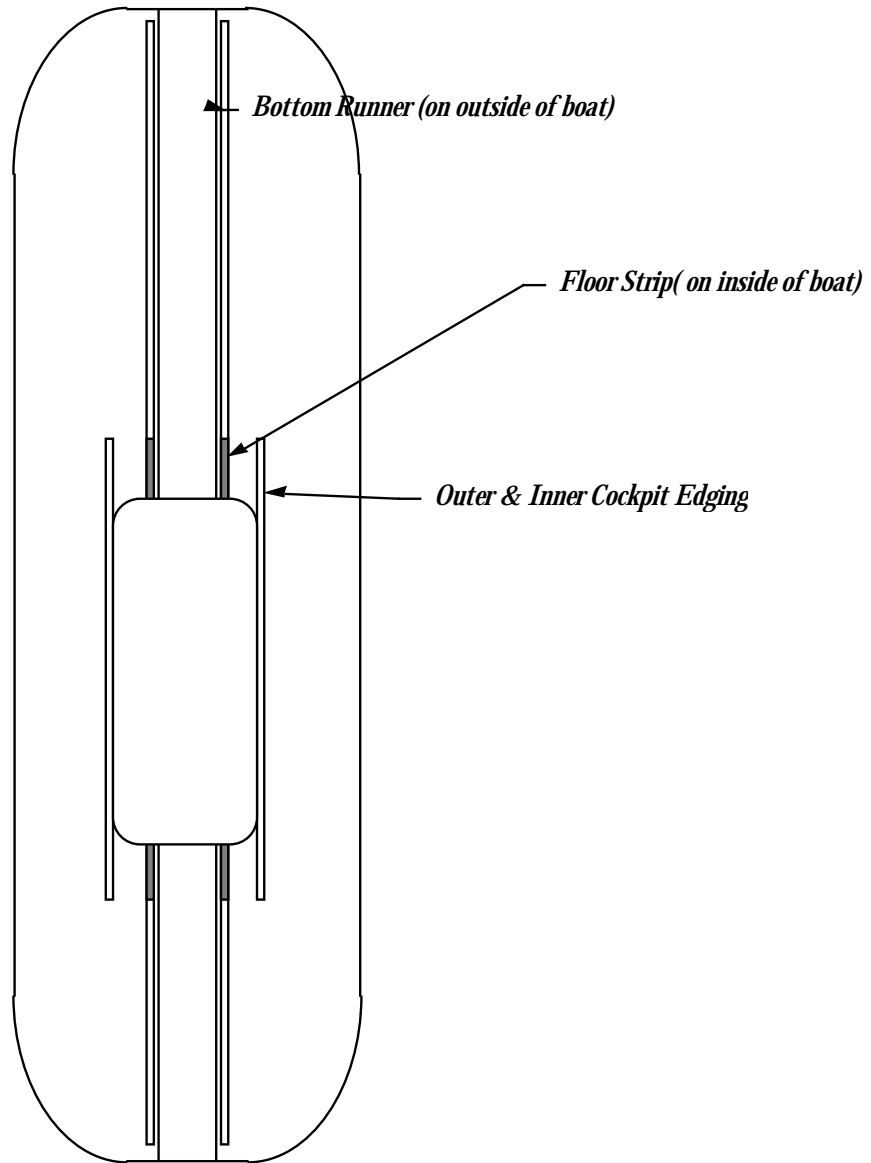

RunnerPlacementDetail

