

**MASSACHUSETTS INSTITUTE OF TECHNOLOGY
HAYSTACK OBSERVATORY
WESTFORD, MASSACHUSETTS 01886
March 6, 2008**

Telephone: 781-981-5407
Fax: 781-981-0590

To: VSRT Group
From: Alan E.E. Rogers and Preethi Pratap
Subject: Laboratory demonstrations/experiments

1] 2-element interferometer using LNB feeds without parabolic dishes.

Title: 2-element interferometer using LNB feeds

Purpose: To demonstrate radio wave interferometer fringes, measure the wavelength, illustrate the principles of making radio images, show the radio emission from fluorescent lamps and illustrate the principle of radiative transfer and optical depth.

Materials: pc, USB frame grabber, Power supply, power injector, CAE~9220 amplifier, 15~amplifier, power combiner, 2 direct TV triple feed LNBFs, detector 2 27 w CFLs, tripods, clamps etc.

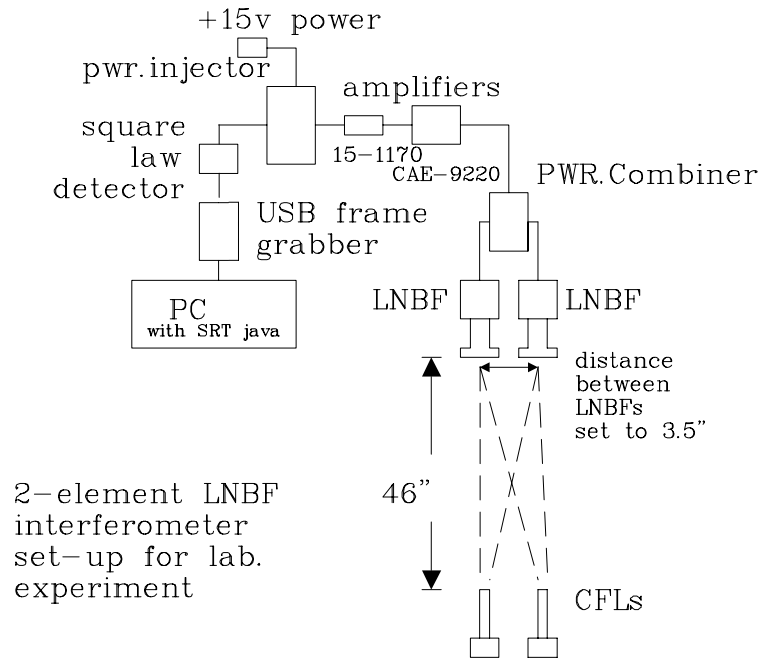

Figure 1.



Figure 2. 2-element interferometer using LNBF's and CFL's as signal sources.

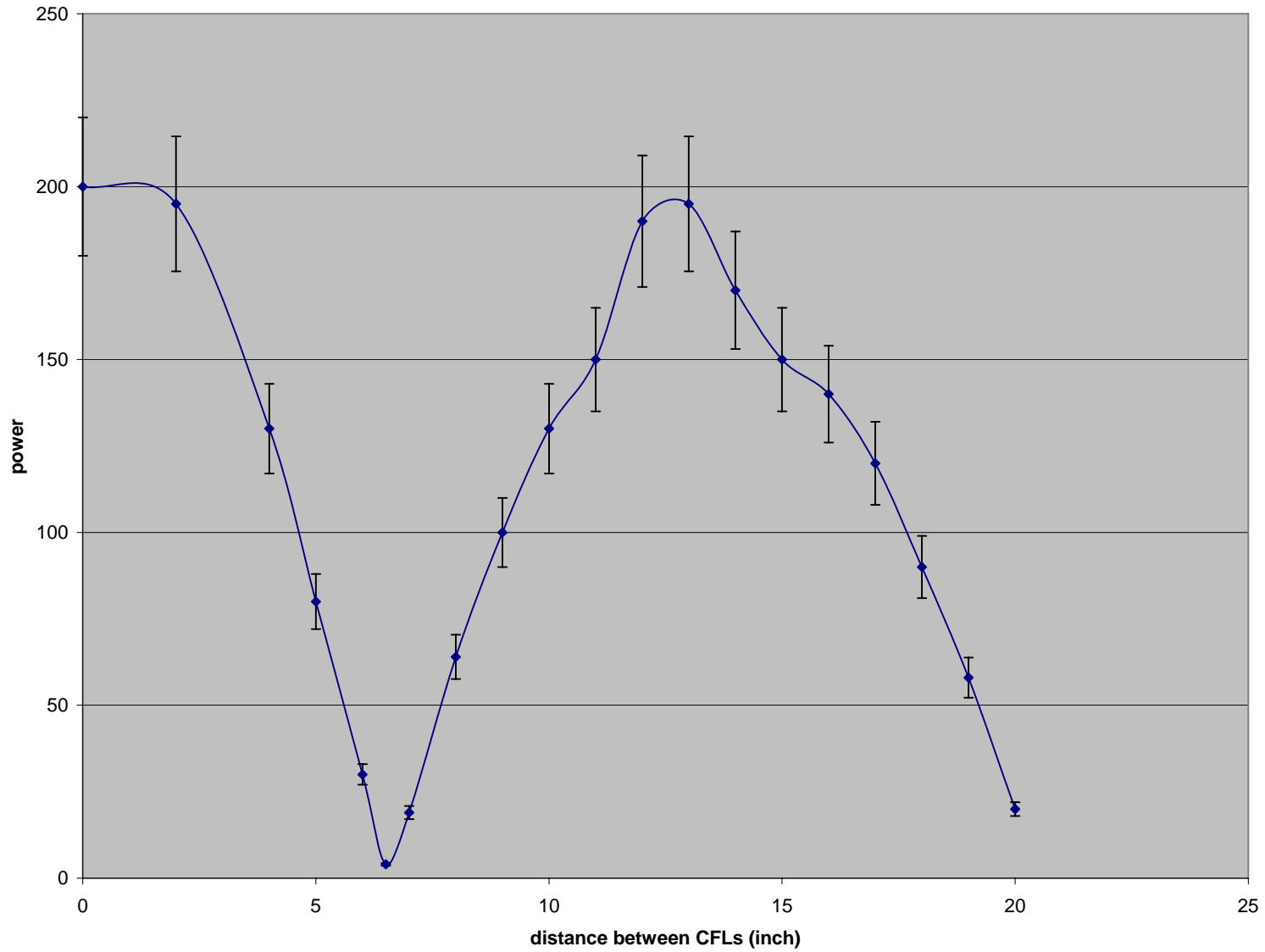

Figure 3. Fringe power (also known as fringe visibility) for a double source.

Method: Set-up a 2-element interferometer with LNBFs as shown in the schematic diagram of Figure 1 and the photograph of Figure 2. Measure the distance between the active LNBFs. With the lamps as close together as you can get them check the output power by turning on one at a time. [The fringes produced should be almost exactly the same for each lamp and approximately double for both lamps.] Now measure the fringe power vs distance between the lamps. A typical plot is shown in figure 3.

Questions/exercise for student

- 1] Examine the power vs angle of the lamp. Notice the power drops when the lamp is pointed sideways and peaks when pointed towards interferometer. Is this the effect of resolution? Or is this due to the change in column density which affects the opacity? If it is due to opacity how would you expect the power to change with angle?
- 2] How would you estimate the brightness temperature of the fluorescent lamp? Can you get fringes on an incandescent lamp? Why are they so weak?
- 3] What polarization are you receiving? How would you find out?
- 4] Set-up the interferometer with 90° mirror. What is the effective baseline? Measure the effective baseline by finding the first null with a double source. Measure the cross-pol response. [If you want to switch pol of one feed you will need separate power injectors.]

Data analysis:

This first null of the double source was measured to be at 6.5 ± 0.2 inches at a distance of 46 inches from the LNBFs. Since null occurs when there is half a wavelength path length in the double difference of the CFLs to each feed we have

$$(\lambda/2)/3.5 = 6.5 \pm 0.2/46 \text{ or } \lambda = 0.99 \pm 0.03 \text{ inch} = 11.93 \pm 0.36 \text{ GHz}$$

- 2] 2-element interferometer using one LNB with parabolic dish and one LNBF as a reference antenna.

Title: 2-element interferometer laboratory demonstrator

Purpose: To demonstrate the principles of radio interferometry, measure the beamwidth of a parabolic dish. In addition the experiment demonstrates the reversal of the sense of polarization upon reflection.

Materials: Same as in previous experiment plus one 18" dish. Metal plate reflector [added room space as the distances between antennas and lamps is now increased to 19' to be in the far field.]

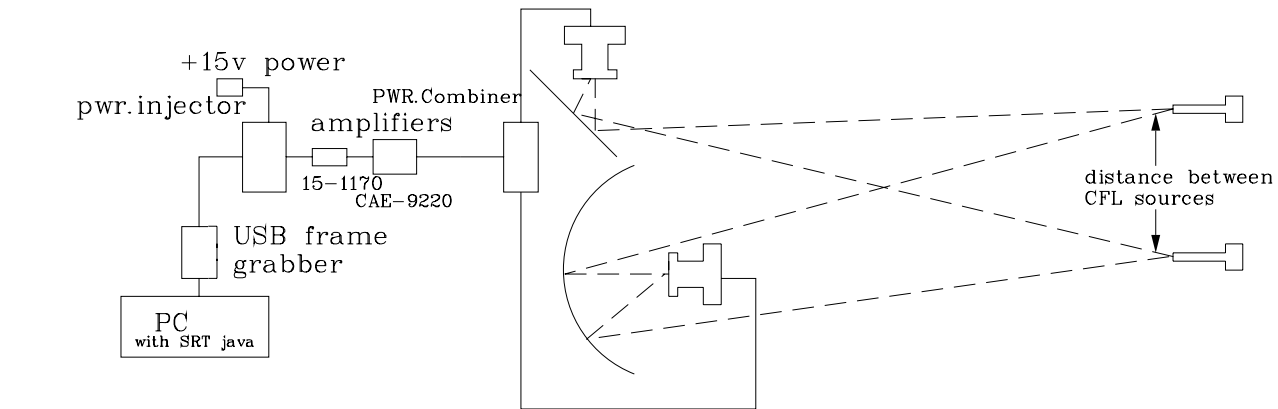

2-element LNB
interferometer
set-up for lab.
experiment

- Notes: 1] The path lengths from the LNBs to the CFLs need to be equal to within ~ 6" or about 500 ps.
 2] Drawing is NOT to scale
 3] A small mirror should be used to set-up initial pointing of the dish

Figure 4



Figure 5. 2-element interferometer using DirecTV dish the view is from the CFL signal source. Note: the optical reflections of the active feed used as an initial alignment guide and LNB as a “reference” antenna.

Method: Set-up a 2-element interferometer with one DirecTV dish (and its associated LNBF) and a LNBF as a reference antenna. The set-up is shown in figure 4 and the photograph of figure 5. In order to obtain fringes the polarization of the reference LNBF U.C.F. is reversed using a small plane metal plate as a mirror. The geometry can be checked by viewing the optical reflections of the feeds from the location of the CFL radio sources. The fringe power vs the separation of the CFL sources is shown in Figure 6.

The fringe power was also measured vs the pointing angle of the parabolic dish with the 2 CFLs as close to each other as possible. The data is shown in figure 7. The y-axis is the power which in this case is the output of the SRT java program squared since the fringe visibility is the product of the voltage pattern for each antenna.

Data analysis: The first null of the visibility was found at $9.0 \pm 0.2''$. This corresponds to an angle of 2.26 ± 0.05 degrees. Since this angle equals a half wavelength divided by the baseline we estimate a baseline length of $12.7 \pm 0.2''$ assuming the previously measured wavelength of 0.99 inches.

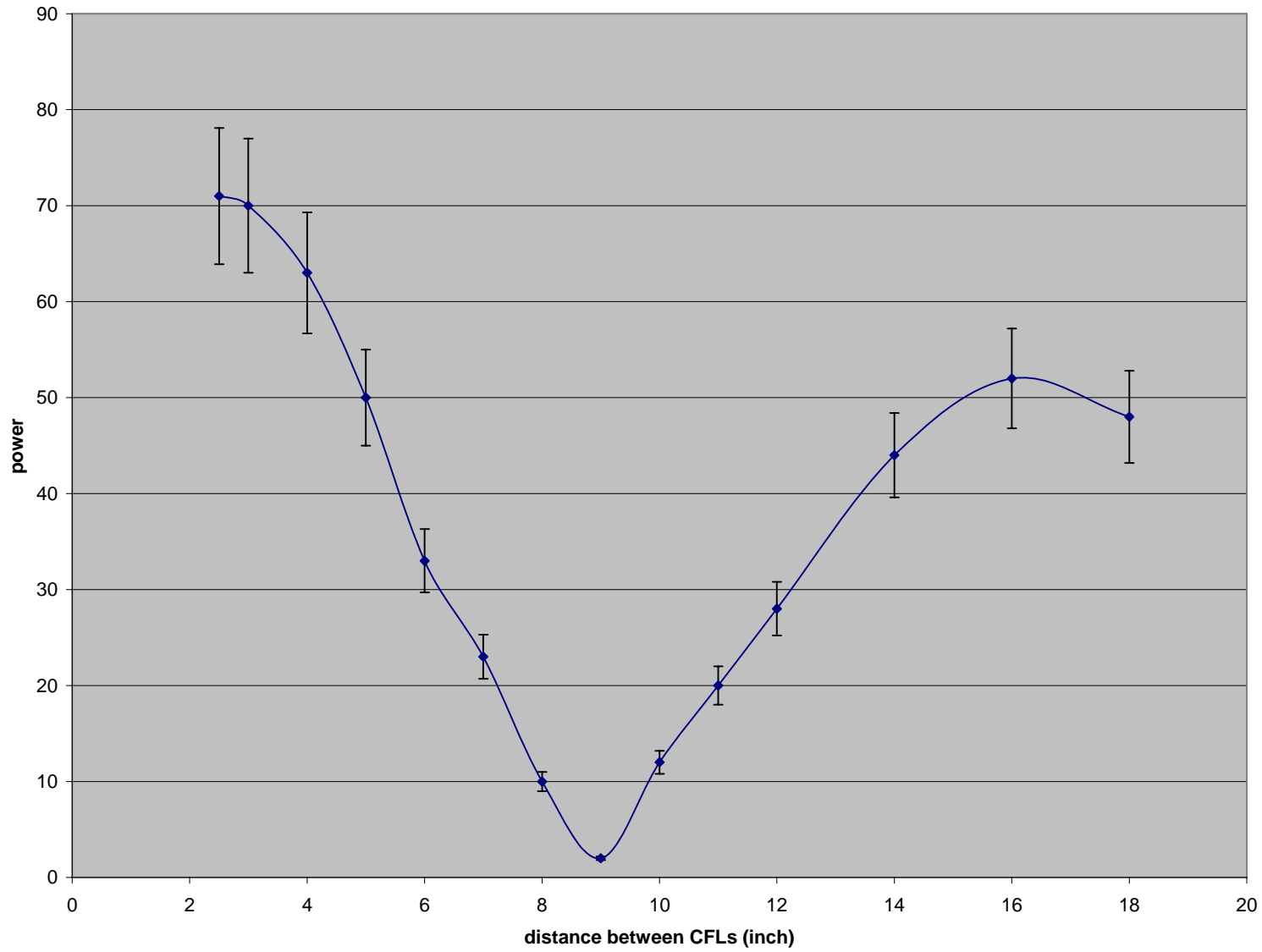

Fig. 6 – Fringe power vs distance between lamps

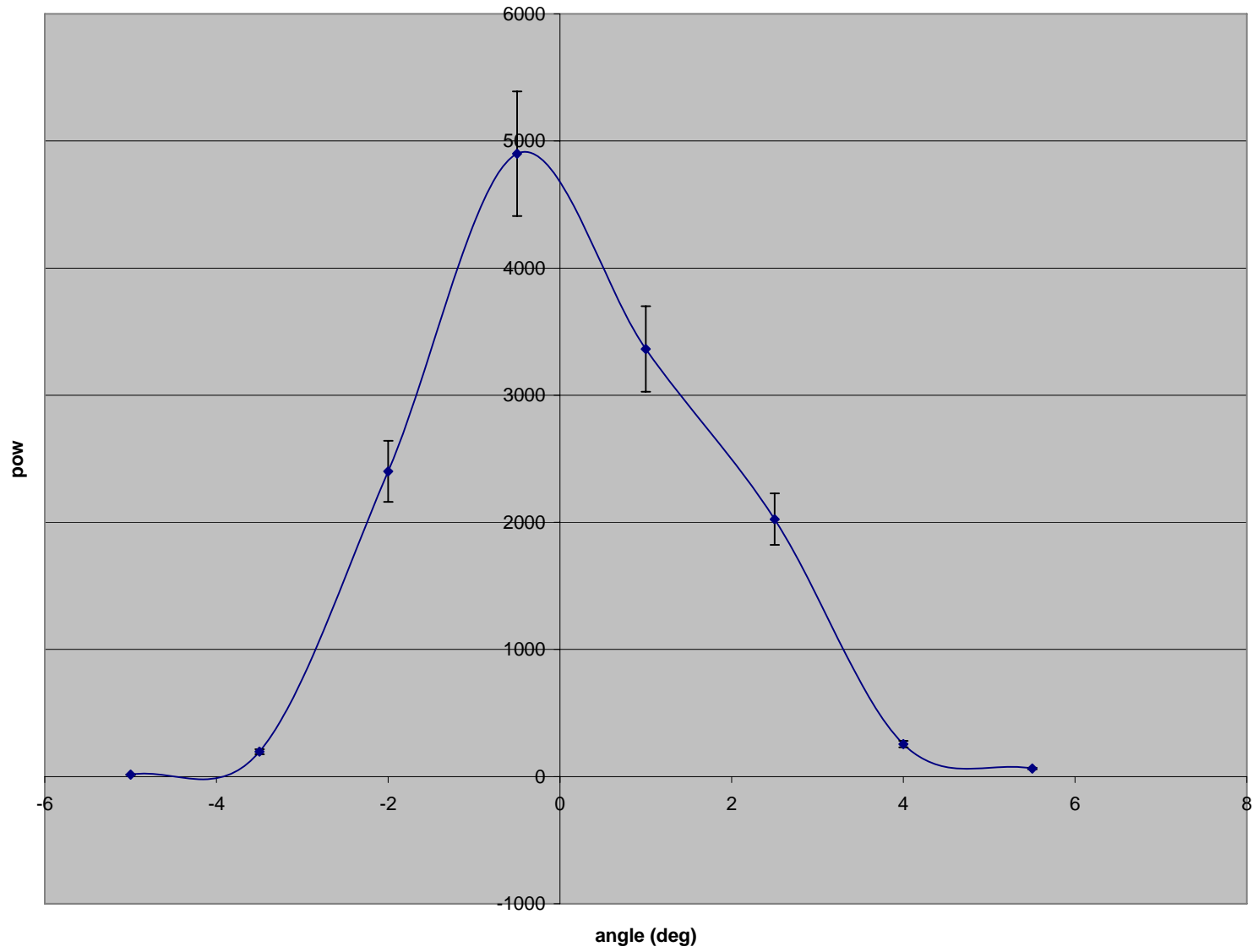

Figure 7.

The full beamwidth at half power points is estimated from the data of figure 7 to be 4 degree at the half power points. This can be compared with the theoretical value of about $1.2\lambda/d$

Where λ = wavelength

d = antenna diameter

Questions/exercises for student

- 1] Measure the isolation of the LCP and RCP polarizations but removing the mirror in front of the “reference” LNBF and observing the drop in interferometric fringe power.
- 2] Measure the effective interferometric bandwidth by moving the reference antenna along the line to the CFL and plotting the power vs distance. [The power should be a maximum when the delays from the CFL to the power combiner via the 2 paths are equal. In optical interferometry this is known as the “white fringe” condition.]
- 3] In October 1970 the radio source 3C279 was observed at 7840 MHz to have a minimum in the fringe visibility at 20 hours Greenwich sidereal time on the interferometer between Haystack and Goldstone. This minimum corresponded to a projected baseline in the directions of 3C279 of about 2510 km. If 3C279 is modeled as a double source what was the angular separation of the 2 components in October 1970? [ans. 1.6 milliarcseconds]. By February 1971 this angular separation, as determined from the times of minima. In the visibility has increased by 9%. This led astronomers to suggest that quasars eject particles into a jet at speeds close to the universal speed limit of the velocity of light from observations with a 2-element interferometer.

References

A.R. Whitney, I.I. Shapiro, A.E.E. Rogers, D.S. Robertson, C.A. Knight, T.A. Clark, R.M. Goldstein, G.E. Marandino and N.R. Vandenberg, 1971, “Quasars Revisited: Rapid Time Variations Observed Via Very-Long-Baseline Interferometry,” *Science*, **173**, 225-230.

Krauss Radio Astronomy.