

MASSACHUSETTS INSTITUTE OF TECHNOLOGY
HAYSTACK OBSERVATORY
WESTFORD, MASSACHUSETTS 01886

February 15, 2007

Revised February 27, 2007

Telephone: 781-981-5407

Fax: 781-981-0590

To: VSRT Group
 From: Alan E.E. Rogers
 Subject: 2 axis mount for VSRT tests

An inexpensive (~\$150) azimuth/elevation mount for a pair of 18"×21" offset direct TV parabolic dishes can be put together using a pair of SG2100 DiSeqC motors (which support 1.2 Goto×function). The SG2100 is rated for a single dish up to 1.2 m but may be able to reliably point 2 smaller dishes whose combined area is less than the larger single. In a strong wind the moment on the elevation drive is less than it would be for the larger dish but the larger center force offset for the azimuth drive could reduce its life and tests will be needed to see if the design I propose is reliable.

The mechanical design is illustrated in Figure 1 and photos shown in Figures 2 and 3. The motors are controlled and powered by 2 separate Stab MP01 DiSeqC 1.2 control units with the remote wiring shown in VSRT memo #5. The weeder WTSSR-M solid state switch has 5 switches labeled A thru E which can be used as follows:

- A Azimuth decrease
- B Common go to stow command
- C Azimuth increase one step (A if azimuth motor points down)
- D Elevation increase
- E Elevation decrease

The signals from the pair of dishes are added and the fringes extracted using the VSRT's em2820 based video grabber. The processing is supported by the Java code and is selected in the srt.cat file using keyword VSRT. With the 2-axis mount the Sun can be scanned using the "npoint" command. In fact the pair of dishes can be used just like a "single dish".

The system responds only to correlated noise so that pointing the pair at an extended object like the ground or trees will produce little, if any, correlated output. Pointing the antenna at an object of brightness temperature T_B and angular size θ will produce and output in each antenna of

$$T_A = \frac{\eta T \theta^2 \pi A}{4\lambda^2}$$

where T = object temperature

η = aperture efficiency

θ = angular diameter of object

A = geometric area of antenna

λ = wavelength

T_A = antenna temperature of each antenna

If we use the relation between aperture and beamsize

$$T_A = T \left(\frac{\theta}{\theta_b} \right)^2 \left(\frac{(1.22)^2 \pi^2}{16} \right)$$

where θ_b = antenna beam full width

To use a vane as a calibrator its angular size must be much smaller than the beam size and be far enough away to be in the far field. These 2 conditions are

$$\theta < \theta_b$$

and distance $> D^2/\lambda$

For example a 12" diameter absorber at 115' subtends an angle of 0.5 degree. This absorber can be used to calibrate the fringe amplitude. Since the calibrator is close to the same angular size as the Sun and moon. In this case

$$T_{moon} = (A_{moon}/A_{cal})T_{cal}$$

$$T_{Sun} = (A_{Sun}/A_{cal})T_{cal}$$

where A = fringe amplitude

T = brightness temperature

The reliability still needs to be tested and shrouds need to be designed to keep water and ice off the connectors. If shrouds are not asked the mount needs to be covered when not in use. Note that the azimuth motor has been oriented with the connectors on the top. This is not a good configuration for protection from the weather but reversing the orientation results in a more awkward mount.

Parts list for 2-axis mount (assuming parts already exist for 2 antenna VSRT with mount).

Part	Desc	Source	Qty	Unit cost
SG-2100	DiSEqC 1.2 H-H motor	Sadoun.com	2	75
MP01	Stab MP01 DiseqC control	Sadoun.com	2	39
WTSSR-M	RS232 solid state switch	Weeder	1	69
#0271	6ft DB9 M/F extension cable	Cabletogo.com	1	9

Other items:

1.25" PVC SCH40 pipe 24" long

Elevation adapter plate (see fig 5.)

+12 or +15 v power source

Misc. F-cables and/or BNC cables and adapters (see fig. 4)

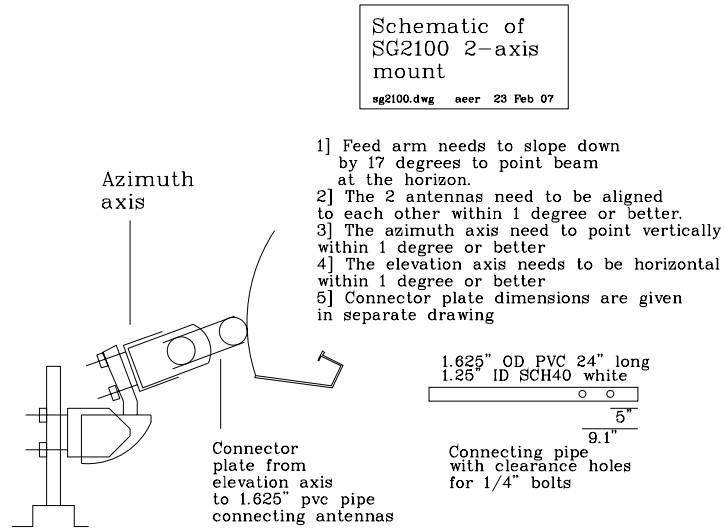

Figure 1. 2-axis mount for a pair of direct TV dishes



Figure 2. Azimuth/elevation mount using 2 DiSeQC SG2100 motors



Figure 3. Front view of pair of dishes acting as a short baseline interferometer.

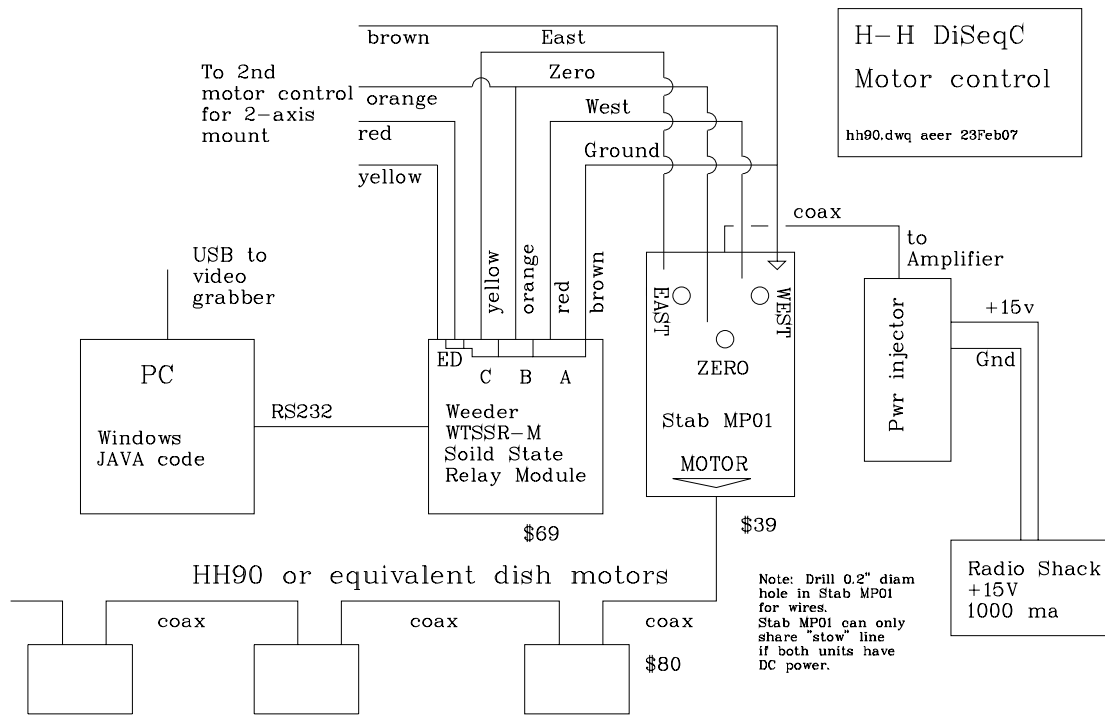

Figure 4. Wiring

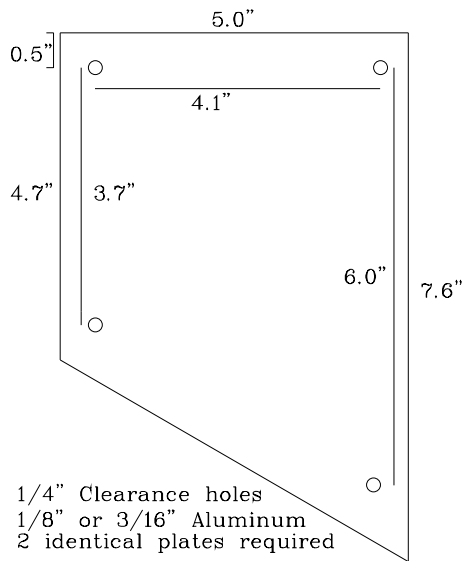

Figure 5. Connector plate