

Exploding Wires

Principles, Apparatus, and Experiments

Steve Hansen



the Bell Jar

Project Series

Exploding Wires

Principles, Apparatus, and Experiments

© 1993-2011, Stephen P. Hansen

The content of this booklet is derived from articles which have appeared in, or are associated with, *the Bell Jar*, the quarterly journal of vacuum technique and related topics in physics for the amateur experimenter.

Further information on this journal will be supplied on request from the author at :

the Bell Jar

www.belljar.net

CAUTION: *Working with exploding wires requires the use of high voltages and very high value current pulses. Do not attempt any experimentation in this area unless you have an appropriate level of knowledge and experience. While care has been taken to assure the accuracy of the material presented, the author may not be held liable for any damages and/or injuries resulting from the use of misuse of this information.*

INTRODUCTION

The first thought which might come to your mind when the term *exploding wire* is mentioned could be what you observe when a fuse blows: a brief flash of light perhaps accompanied by a slight pop. In actuality the two are fundamentally quite different. Whereas the fuse wire melts with some associated arcing as the wire forms into hot droplets, in the exploding wire process electrical energy is dumped into the wire at such a high rate that the wire literally detonates in a burst of hot plasma with an accompanying sonic shock wave.

The use of an electrical discharge to heat or vaporize metal wire or foil was first noted in the 18th century. Martin van Marum (1750-1837), a multifaceted Dutch natural philosopher who performed research in various disciplines including botany, geology and medicine, as well as electricity, was able to heat and melt 70 feet of thin wire using the discharge from a battery of Leyden jars (an early form of capacitor). Benjamin Franklin coated cardboard silhouettes with gold and silver leaf and then used a Leyden battery to vaporize the foil. When placed in close proximity to a piece of paper, the image of the silhouette would be reproduced on the paper. Edward Nairne (1726-1806), an English instrument maker and a friend of Franklin's, was, in 1774, the first person to note the true exploding wire phenomenon.

Pretty much a curiosity for most of the last 200 years, the exploding wire phenomenon became the subject of intense research in the 1950's. These explosions, lasting too brief a time for the wire to fall apart before complete vaporization occurs, have been used to generate very high temperatures (10's of thousands of degrees), initiate shock waves, produce dense plasmas, act as light sources for high speed photography, and even to form sheet metal into complex shapes.

Currently, exploding wires are being used in energy research. "Wires" made of frozen deuterium are fed into vessels where very high power discharges are used to produce fusion reactions. As fuel, the frozen fibers are more efficient than deuterium gas for producing dense plasmas.

THE EXPLOSION PROCESS

Going back to the case of the fuse, the current rise is usually fairly slow (the better part of a millisecond). First the wire becomes fused. Then the molten metal forms into droplets due to the action of surface tension. Usually there will be arcing between the droplets before the circuit is finally broken. Figure 1 is a schematic representation of the sequence of events for a blowing fuse.

The exploding wire phenomenon depends upon a very fast current rise, on the order of a few microseconds. Conn [1] described the process as comprised of six steps:

- Heating of the wire by the heavy current passing through it.
- Formation of a liquid column of metal replacing the wire.
- Development of instability in the wire which forms *unduloids* (figures of rotation) and causes the appearance of striations in the metal vapor. (This is due to the mechanical and magnetic forces created by the discharge and heating.)
- Upon the disruption of the arcs formed between the unduloids, a "dark interval" results during which no current flows through the wire; the voltage remains constant.
- A sudden flash of light is next observed, the spectrum of which is continuous and independent of the material used. Thereafter emission and absorption lines are observed depending upon the materials used.
- One or more sonic shock fronts are created during the same interval.

Figure 2 is a high speed x-ray flash photograph by Früngel [2] showing an exploding iron alloy wire. The exposure time for each frame was 0.3 microseconds and the film in the camera was moving at 10,000

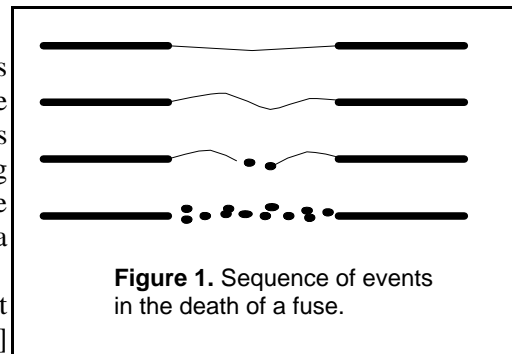

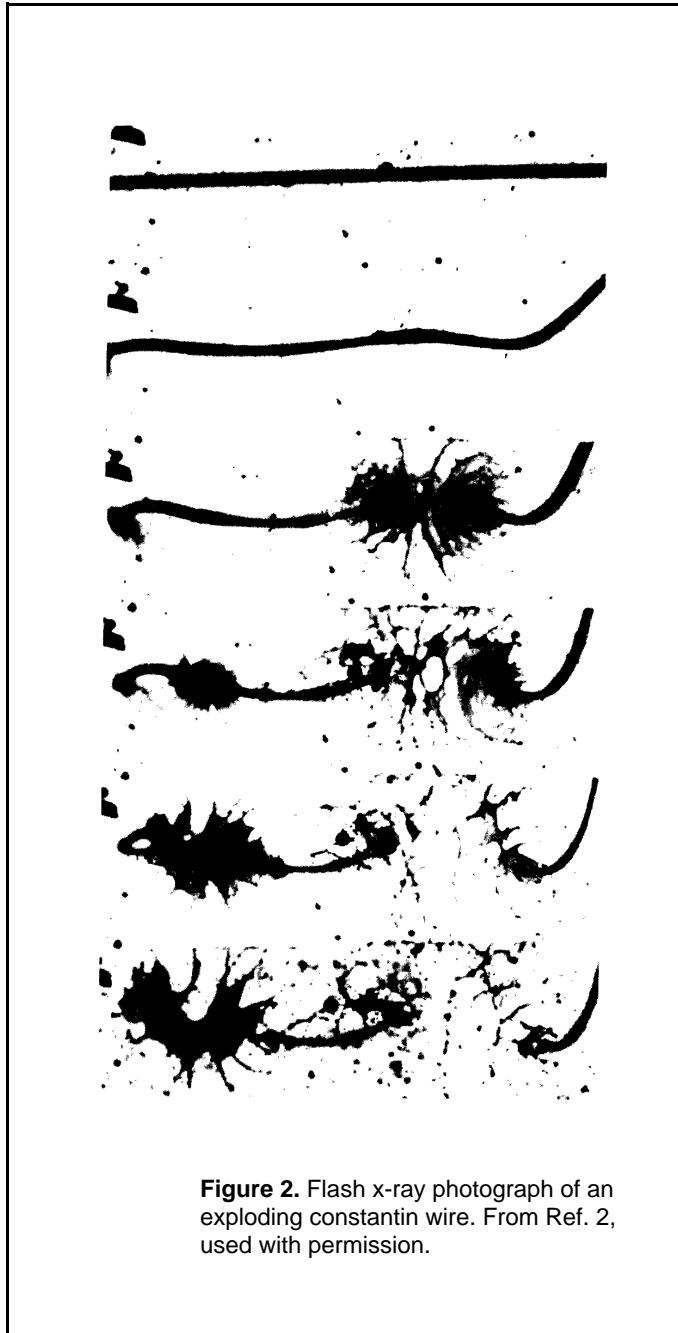

Figure 2. Flash x-ray photograph of an exploding constantin wire. From Ref. 2, used with permission.

feet/second. The photograph clearly shows the initial distortion of the wire and then the centers of the explosion. Note the hyperbolic shaped curves which form in the third frame - these follow the power fields.

EQUIPMENT OVERVIEW

The standard method for exploding a wire is to feed energy to it via the discharge of a high voltage capacitor.

The basic equipment for exploding wire work consists of a high voltage power supply (2 to 3 kV is a good range to work with), one or more oil or plastic dielectric capacitors which will store a few hundred to a thousand watt-seconds (Joules) of energy, and a well insulated switch for discharging the capacitor through the wire.

The energy, E , stored by the capacitor is computed per the following expression:

$$E = \frac{1}{2}CV^2 \text{ (Joules)}$$

where C is the capacitor rating in farads and V is the charging potential in volts. A typical "home size" capacitor bank of 200 μ F at 2000 volts would therefore have an energy content of 400 watt-seconds. If the discharge period of the capacitor were 10 microseconds, the power impulse in watts would be E (400 Joules) divided by the duration (10 μ sec) or 40 megawatts.

The supply described may be divided into two subsections: the low current dc charging circuit and the high current discharge & control (sequencing) circuits. This power supply is manually sequenced and the simple discharge circuit is adequate for microsecond range pulses. Provisions for automatic control could be incorporated in this basic supply.

The sequence of events for the operation of such a power source is illustrated in Figure 3. The first stage is the charge cycle where energy is slowly (relatively speaking) dumped into the capacitor. The charging process follows an exponential curve with a fast initial voltage rise which then trails off as full voltage is reached. The charge rate is determined by the *time constant* which, in seconds, is equal to the value of the capacitor (in farads) times the charging resistance (in ohms). The voltage across the capacitor will be about 95% of the charging voltage after a period of three time constants. At the beginning of the charge cycle, the capacitor will briefly act like a short circuit. The value of the charge resistor should be chosen so as to limit the initial charge current to no more than the maximum output current of the power supply. Otherwise, damage to the diodes, transformer, or meters could result. Likewise, the resistance should not be so high as to make the charge cycle unduly long.

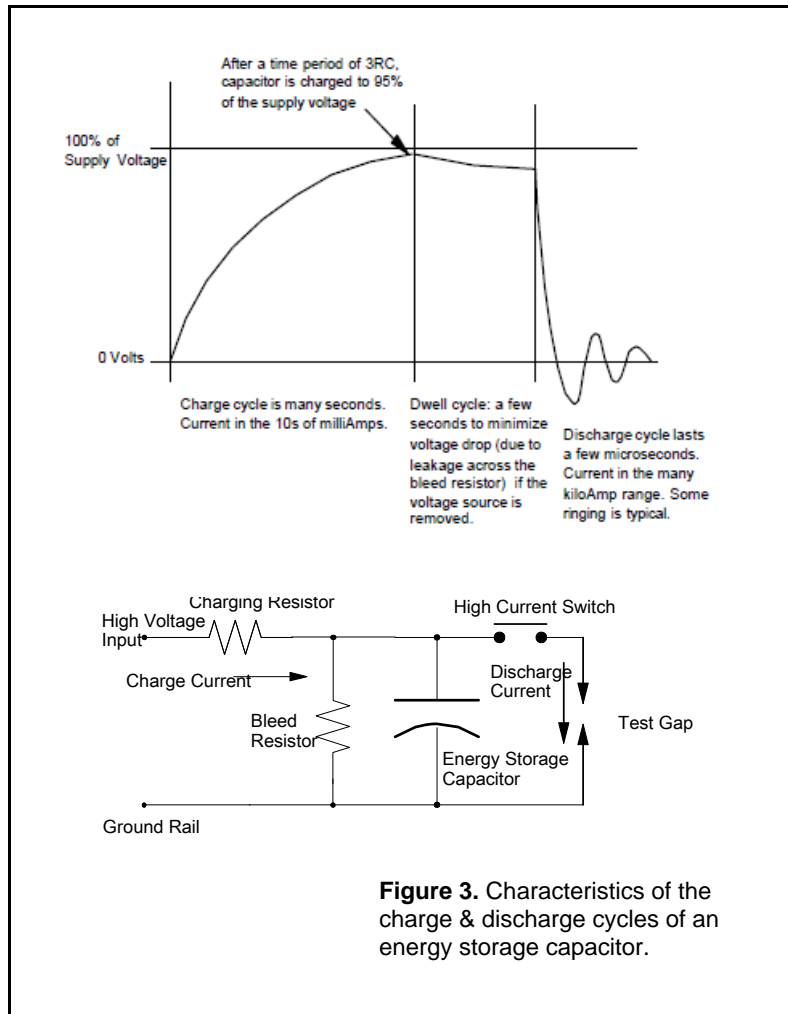

Upon reaching full (or nearly full) charge, the power supply should be switched off in preparation for the discharge cycle. This interim dwell period should be fairly brief in order to prevent the loss of capacitor charge through any of the various leakage paths which shunt the capacitor. These can be the meter circuit, internal leakage in the capacitor, bleeder resistors, etc.

The discharge cycle is abrupt and should only last a few microseconds. (Special discharge circuits such as are used in pulsed lasers and fusion devices have optimized discharge paths in which full discharge takes place in a matter of thousandths of microseconds or even less.) Typically, the discharge will ring a few times before dying out. This ringing is one reason why polarized electrolytic capacitors should not be used in this type of application. The reversals can lead to the catastrophic failure of this type of capacitor. (Another reason is that electrolytic capacitors have a relatively high internal resistance - this slows down the discharge process.)

DC CHARGING CIRCUIT

It is not my intent to give a detailed tutorial on power supply design. Almost any edition of "The Radio Amateur's Handbook" (ARRL, Inc., Newington, CT) has good and relevant information on the various aspects of high voltage dc power supplies. Avoid buying anything new unless absolutely necessary as the major components can be obtained from any of a number of surplus houses. However, high voltage rectifier diodes do seem to be scarce on the surplus market and these may have to be purchased new.

Figure 4 shows the entire supply. The charging circuit lies across the upper part of the figure. I have deliberately left out any specific component values as these will vary according to the specifications of the step up transformer which you are able to obtain. For flexibility I would recommend a charging circuit which can produce 2 kV at about 50 mA. However, voltages in the 1 to 3 kV range are satisfactory for most exploding wire experiments. Be cautious about the lure of higher voltages - the system can quickly become unwieldy from a safety standpoint. The output voltage of the hv transformer is continuously adjustable by means of the autotransformer. For rectification, a full wave center tap rectifier is shown. Alternatively, a full wave bridge could be used. Current limiting is provided by R_s . Use a string of wirewound power resistors for this (bare Radio Shack "perf" board makes a good base for stringing resistors). While most power resistors are good for several hundred volts, I tend to be conservative and keep the maximum voltage drop per resistor to about 200 volts. Two meters are essential: a voltmeter (located after the charging resistor string so that the capacitor voltage is indicated) and a milliamp meter. Keep the meters on the ground side of the circuit as noted. The voltmeter will most likely require a multiplier resistor, R_m . Of course, these are usually not available with surplus meter movements. An acceptable alternative is a string

of 1%, ½ watt resistors. Again, keep the voltage per resistor in the 200 range. For flexibility, you may want either a positive or negative ground. This will require that you be able to swap the rectifier and meter connections. Using banana plugs and jacks makes this easy.

DISCHARGE & CONTROL CIRCUITS

The discharge circuit is shown in the lower part of Figure 4. This consists of the capacitor, the high voltage drop relay, the test gap, and a charge inductor. Locate the discharge circuit away from the charging circuit with all high current (dark/thick lines in the figure) wiring as short as possible to minimize the loop inductance. These cables can be made from auto battery jumper cable wire with clear flexible plastic (vinyl) tubing slipped over the wires to provide additional insulation. Terminations are best made with heavy copper lugs. Check a welding supply store for these. I have also used the braid from high quality RG-8/U coaxial cable. Just strip back the outer jacket and solder the lugs to the braid leaving the inner dielectric under the connection. As before, place vinyl tubing over the cable. The use of the charge inductor is borrowed from radar pulsing circuits. As a safety measure, the inductor will provide a relatively quick discharge path should the gap not fire. The choke should have a low

The use of the charge inductor is borrowed from radar pulsing circuits. As a safety measure, the inductor will provide a relatively quick discharge path should the gap not fire. The choke should have a low

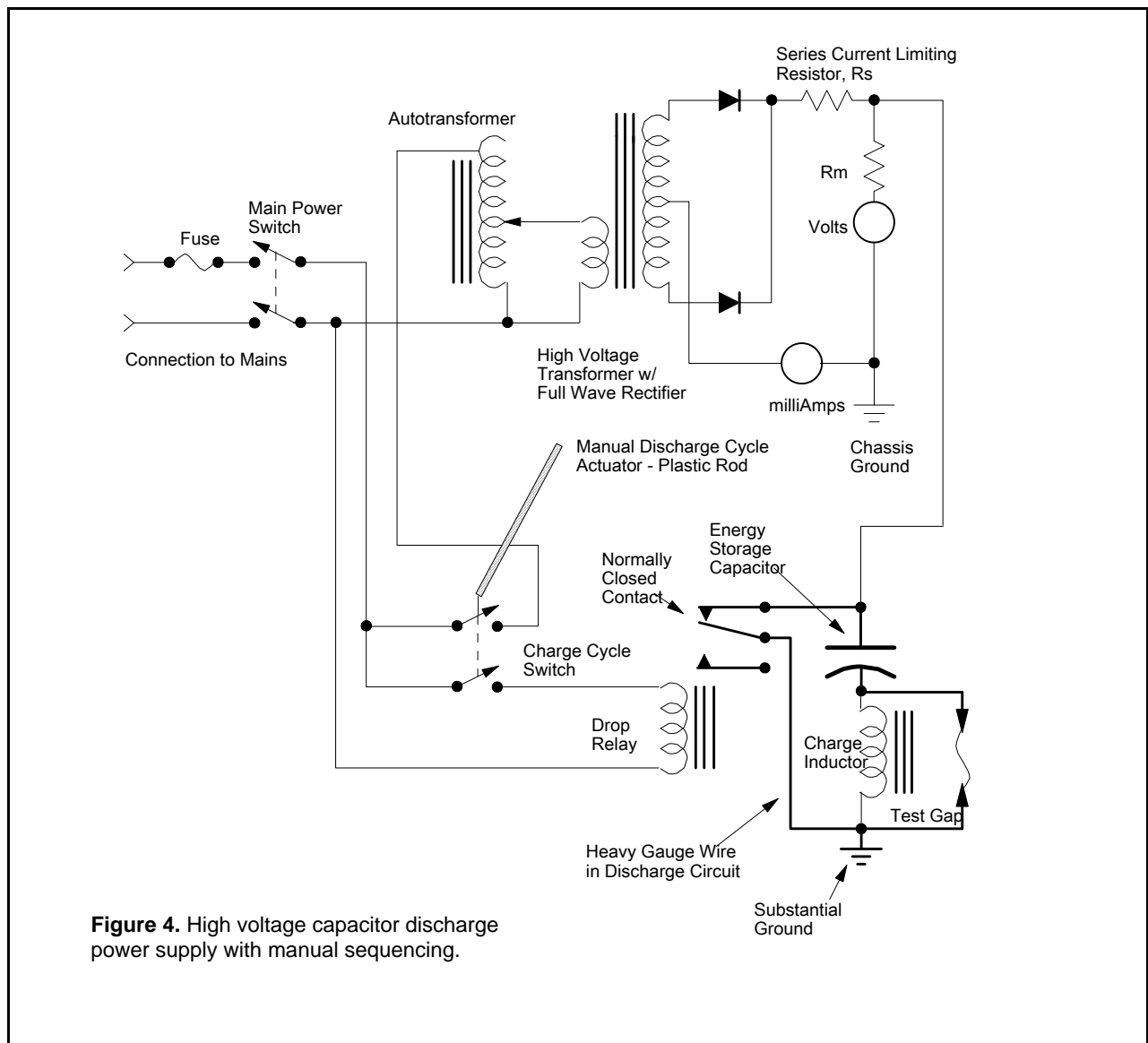
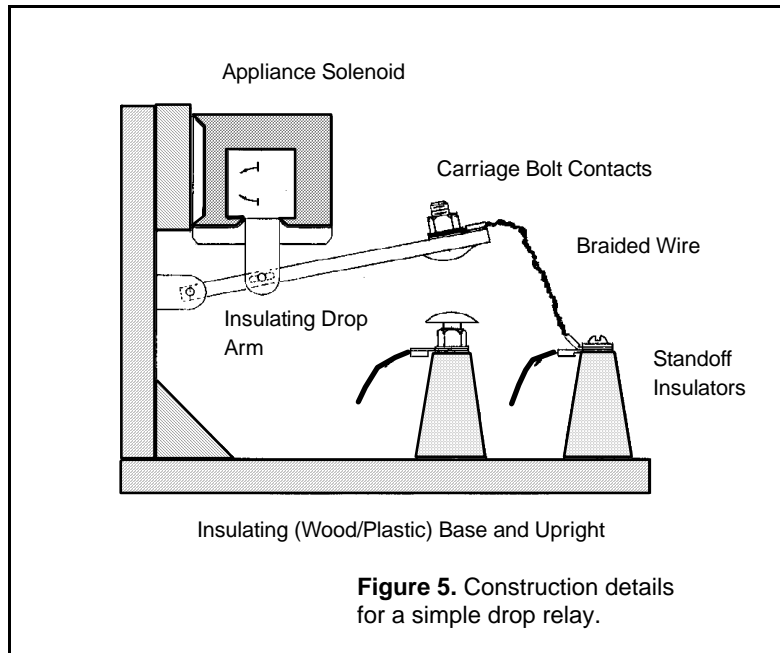

Figure 4. High voltage capacitor discharge power supply with manual sequencing.



resistance (about 100 ohms). If a suitable high voltage choke can't be found, a string of wirewound (inductive) power resistors may be used. Another approach is to use a standard auto ignition coil as the choke. The high voltage end of the coil is connected to the power supply and capacitor; the primary negative terminal is connected to the ground.

The discharge cycle is initiated when the drop relay is de-energized. (This is also a safety feature.) The relay, as shown in Figure 5, is made using an appliance solenoid. The contacts are the heads of steel carriage bolts. Use the braid from RG-8/U coax for the flex connection. Some sort of "cage" should be put around the relay as bits of molten metal will fly away from the contacts as the circuit is made.

The control circuit is nothing more than a DPST switch that simultaneously shuts off the charging circuit and disengages the contactor when the desired voltage is reached. For safety, put a longish plastic extension on the switch toggle. Don't touch anything else during the cycle.

Keep the capacitor, the drop relay and the charge inductor in close proximity and out of harm's way. Placing all of this inside a grounded metal cabinet is a good idea. The test gap is located in a convenient location but no more than three or four feet from the capacitor.

The remote ends of the cables should be connected to well secured insulators about one foot apart. Figure 6 shows a suggested arrangement. To each of these insulators attach a piece of thick copper wire. I use solid copper house ground wire. These extend inward, between the insulators. The attachment of the fine wire to be exploded to the free ends of these wires is a bit tricky. Solder an alligator clip to each of the heavy wires and then crimp a spade lug to each end of the fine wire. The alligator clip makes a good enough connection to the lug, whereas the fine wire, if directly placed in the clip, will frequently slip through the serrations. Regular alligator clips are able to withstand quite a few uses before they erode enough to need replacement. The lugs are pretty cheap and are easy to fasten with a pair of crimping pliers. Arrange all of this so that you can adjust the distance between the alligator clips from about one inch to around six inches.

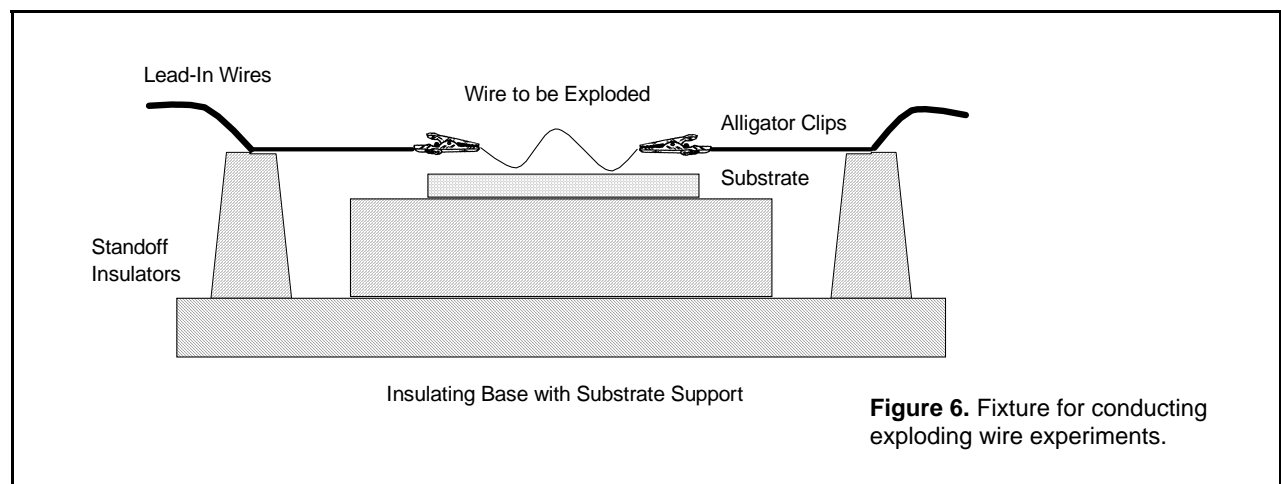

You should have some sort of height adjustment on the lead-in wires to the alligator clips. Just bending the wires is adequate for most purposes. However, if you are trying to place a substrate a certain distance from the exploding wire you may want to add an adjustable stage. An eight inch square of ¼ inch Plexiglas with a screw adjustment in each corner is fine. Conversely, just shimming the substrate with pieces of cardboard, etc. also works well. Just make sure that the substrate, if fragile, is solidly and evenly supported. Otherwise it might shatter.

I place this entire assembly in a plywood box which has a hinged Plexiglas cover and an exhaust blower. The cover helps to keep the noise down (although I still use hearing protectors). The blower vents the smoke to the outside through dryer hose. (I'm not sure if the copper smoke is really hazardous but, in a confined area, it certainly is objectionable. Other wire materials or "tinned" wire could be more hazardous.)

EXPERIMENTS PART 1 - PATTERNS GENERATED BY EXPLODING WIRES

This section will describe how to produce interesting metallic patterns using exploding wires. First, find some thin gauge bare copper wire. A good source of this is heavy gauge (#14 or #16) stranded wire of the type used in permanent wiring. I prefer this to wire strands salvaged from lamp cord as the strands are more substantial. A couple feet of this type of wire will provide enough individual strands in the #26 to #30 range for many experiments.

With the power supply off and the capacitor discharged *and shorted* (a shorting bar can be made from a length of plastic PVC pipe with a metal cross piece - make the cross piece at least long enough to bridge the capacitor's terminals) arrange the discharge electrodes (the alligator clips) about two inches apart. Prepare a similar length of thin wire by crimping a lug onto each end. Then place the wire in the clips. Make sure that the wire is parallel to the stage underneath and place a piece of glossy paper on the stage. Adjust the height so that the paper and wire are just a couple of millimeters apart.

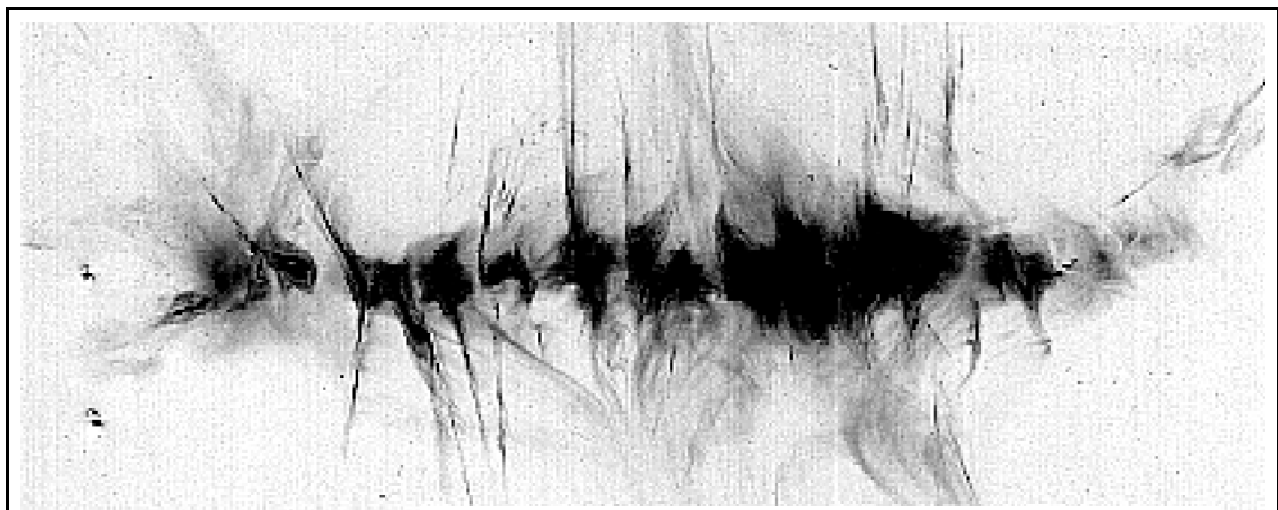

Figure 7. Time integrated pattern deposited by an exploded wire (#27 copper, 3 inch length, 240 μ F capacitor charged to 0.7 kV).

At this point, remove the short from the capacitor, put on your hearing protectors, turn on the power supply, and begin the charging cycle. When the capacitor has been charged to the desired level (I always run my caps conservatively i.e. to a maximum of about 80% of the rated dc value) initiate the discharge through the wire. If all has gone well there will be a bright flash and a loud explosion. Shut everything down and observe the paper substrate. You should see a pattern like the one shown in Figure 7.

Next, using the same length of the same size wire, try varying the discharge energy from levels at which the wire barely explodes up to the maximum energy that your capacitor can supply. You will note the detail of the pattern left at lower energy levels is quite intricate and interesting. You will also note the characteristic shapes much like those shown in the flash x-ray picture of Figure 2. You can also try varying the distance from the wire to the substrate material.

Other interesting effects may be achieved by changing the wire shape. As the pattern is affected by the magnetic fields created in the discharge process, making a loose coil of the wire should have an effect by introducing a change in the magnetic field geometry. That is the case and an example is shown in Figure 8. This pattern was produced by a six turn coil consisting of six inches of #27 copper wire wound on a pencil (subsequently removed) with the lower parts of the loops placed in direct contact with the substrate, a piece of glossy paper. Note the hyperbolic patterns and the rays extending outward, perpendicular to the axis of the coil and parallel to the loops.

More complexity can be added to the pattern by introducing further distortions in the wire. Figure 9 shows the pattern created by a coil (similar to the one of the previous figure) which has been formed into a circle. Here the explosion pattern radiates outward.

Unfortunately, the limitations of the printing process used for this booklet cannot duplicate the detail and coloration which may be observed on the original substrates. Copper wires will show the characteristic metallic coloration in the regions near the wire. Further away will be seen the yellows and blue-greens indicative of copper compounds.

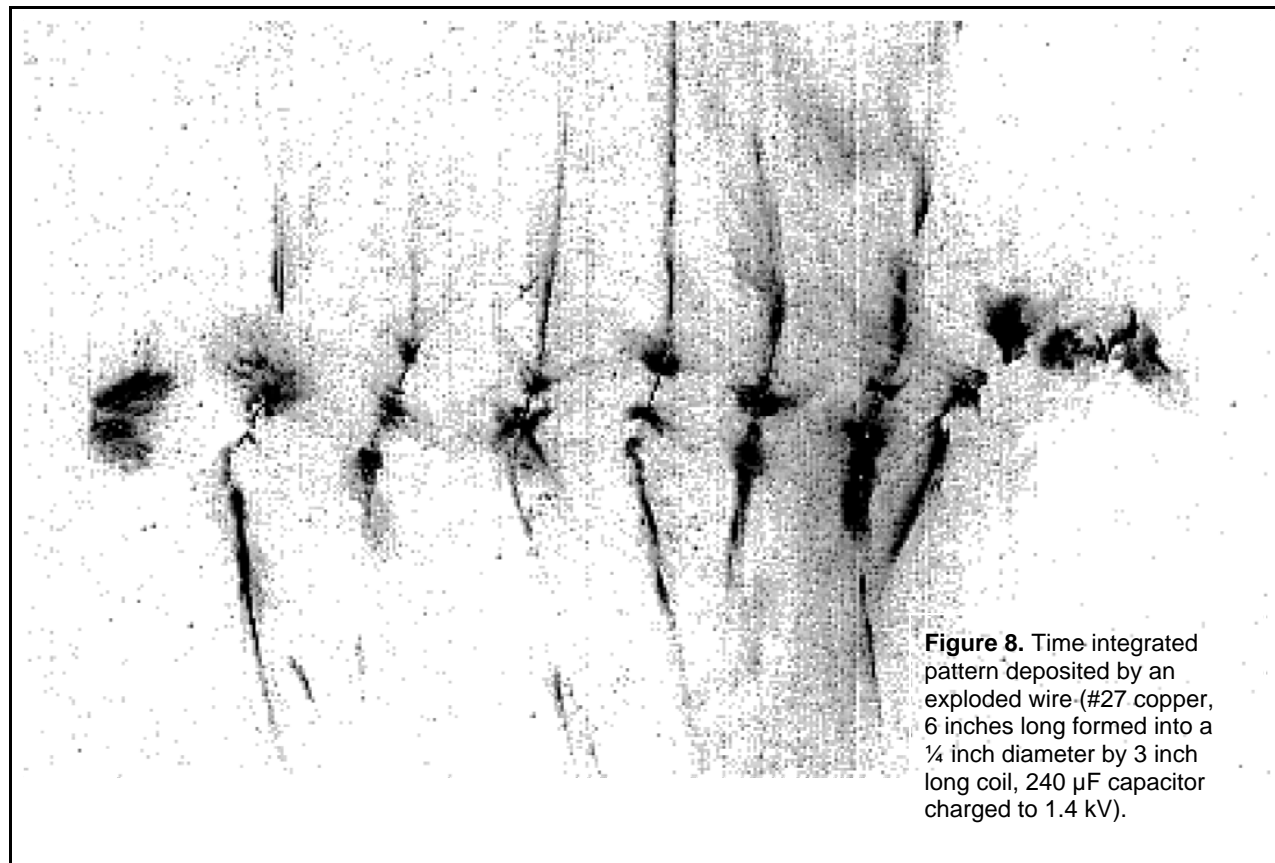

Figure 8. Time integrated pattern deposited by an exploded wire (#27 copper, 6 inches long formed into a ¼ inch diameter by 3 inch long coil, 240 μ F capacitor charged to 1.4 kV).



Figure 9. Time integrated pattern deposited by an exploded wire (#27 copper, 18 inches long formed into a ¼ inch diameter by 9 inch long coil which was then formed into a 3 inch diameter circle), 240 µF capacitor charged to 2.2 kV.

Iron wires (try strands of lighter weight picture hanging wire) will leave brownish deposits while gold (if you can get a piece of gold wire *and then* want to blast it away) leaves a purplish deposit. Nickel wire tends to leave a light, rather pretty, blue deposit. All in all, copper deposits are as attractive as any.

The selection of the substrate material plays an important role in determining the detail seen in the deposit. I have several favorites:

- Heavy, very glossy coated white paper
- Matte white countertop laminate (Formica® or similar)
- Glazed white ceramic tile
- Medium texture ground window glass

The first item may be obtained from art supply stores. Countertop laminates are available in sheets and by the running foot. You might be able to pick up some scraps from a kitchen supply store that also does installations. Ceramic tile is a bit on the expensive side but works quite well. The pattern, as deposited on any of these substrates, is fragile. You can protect the pattern by spraying the surface with a clear acrylic plastic coating.

Frosted glass can be had from glass shops. The frosting is made by sandblasting large sheets and then cutting to the customer's required size. Various degrees of frosting are available. Avoid the real rough stuff as the pattern will not have good resolution. Frosted glass is not too cheap but it is excellent for making permanent displays of your best work. After testing on an expendable substrate such as coated paper, substitute a piece of frosted glass cut to a standard picture frame size (e.g. 8 x 10 inches). Deposit the pattern on the frosted side. After the pattern has been deposited, spray paint this surface with matte white fast-dry paint. The image will be preserved and visible in fine detail from the unfrosted side of the glass. After a bit of practice you will be able to produce very attractive patterns on frosted glass. For display, mount your "artwork" in a frame and hang it on the wall. If you goof, you can usually reuse the glass after etching the pattern with a standard printed circuit board etch solution (provided you used copper).

EXPERIMENTS PART 2 - MECHANICAL EFFECTS OF EXPLODING WIRES

If a wire explosion is contained in some way, the explosion can be quite violent. For example, if the wire is placed between two pieces of glass (e.g. microscope slides), the explosion will shatter the glass into very fine particles. Knowing that, I would not recommend actually trying it due to the hazards involved. A safer and more practical way of demonstrating the effect of a contained explosion may be performed by immersing the wire in a large container of water.

Früangel and Keller showed that a 4 watt-second underwater discharge is equivalent to the detonation of about 1 milligram of high explosive. Thus it should be possible to perform some interesting experiments with underwater wire explosions. (You can also avoid the legal and safety issues associated with trying to acquire and use TNT!)

To test this, find a metal or strong plastic bucket of about five to ten gallons capacity and nearly fill it with clean, fresh water. (Do this in an area where you won't mind some water splashing around.) Place a short strand of thin wire (an inch of #30 wire is fine) between the shield and center conductor of a length of large coaxial cable (RG-8/U with a solid dielectric is good) as shown in Figure 10 and immerse the wire well below the surface of the water. Needless to say, when mixing water with high voltage electricity you have to be very careful. Keep well clear and check your ground connections. When the wire explodes, you will most likely see a plume of water rise several feet out of the container.

The pressures developed in the water by the explosion are significant. This can be shown by immersing a small empty bottle made of thin, rigid plastic in the water. The explosion may well crack the container. This is pretty much how a depth charge works on a submarine.

There are many practical applications for underwater exploding wires and sparks. One is for metal forming. As shown in Figure 11, a piece of metal, perhaps of a type not easily formed by conventional techniques, is placed over a mold in the bottom of a water tank. The cavity which is formed between the metal plate and the mold is evacuated to facilitate the forming process. Once the cavity is evacuated, the wire is exploded and the metal conforms to the shape of the mold. This can be demonstrated in our water tank with a piece of aluminum foil placed on top of a gently contoured object. The explosion will cause a noticeable deformation of the foil.

Geologists have used various explosive methods, including capacitor discharges, in exploratory work using seismological techniques. Here the trick is to efficiently couple the discharge energy to the ground. The general way to do this is to surround the discharge with water. The amateur seismologist can perform "soundings" by initiating subsurface shocks with the simple device shown in Figure 11. Here, our underwater electrode is modified by encapsulating the end in a thick walled toy balloon which is filled with water and sealed to the cable with plastic tape. This assembly is placed in a small, deep hole in the ground which is then filled with well tamped wet soil. To avoid digging a new hole for each subsequent sounding, a casing may be made from a length of 2 inch PVC pipe. The lower end of the pipe should be well perforated with holes for a foot or so and then wrapped with plastic window screen. This will keep the end from filling with dirt yet will be transparent to the sonic shock wave. Dirt should then be packed around the pipe. With the electrode lowered into the bore of the pipe, fill

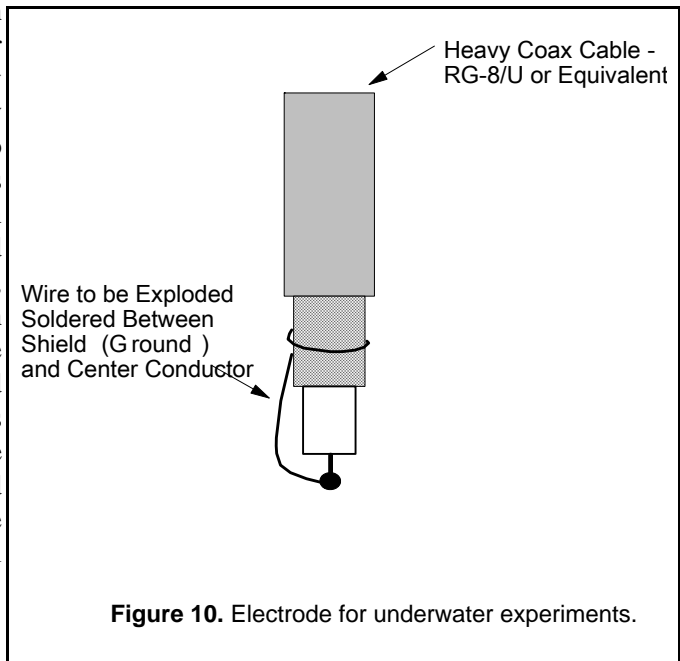

Figure 10. Electrode for underwater experiments.

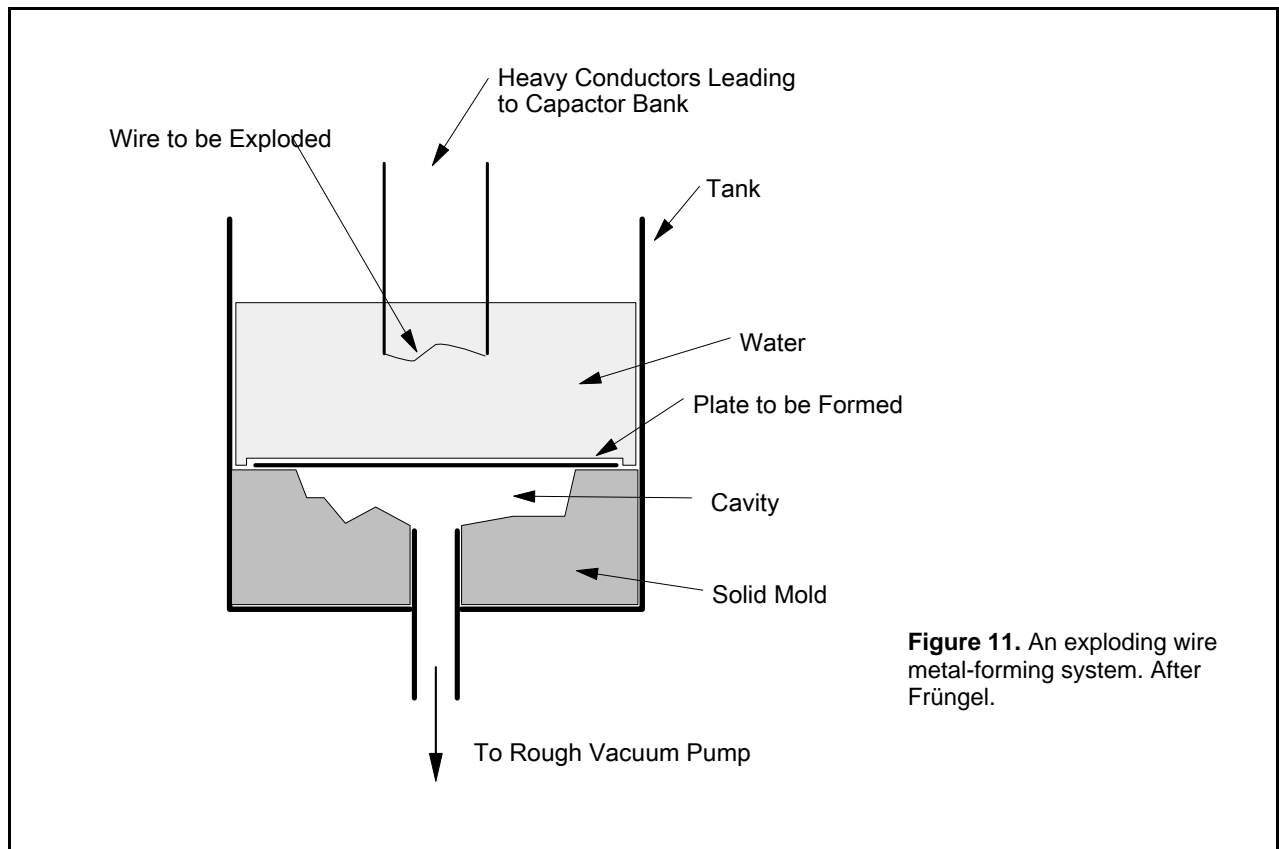

Figure 11. An exploding wire metal-forming system. After Früngel.

the tube with water. A slow, steady water flow might be required to maintain the water level during the entire charge/discharge cycle.

It should be noted that, in the case of underwater discharges, it is not necessary to use a wire in the gap as the water can provide the same action. A short gap will suffice as long as the power supply and capacitor bank can supply enough voltage to break down the water gap to generate the plasma. This is particularly useful in applications where multiple, lower energy shocks are to be delivered. For higher power and assured firing, the use of a wire in the gap is a plus.

A more recent application of underwater electrical discharges is the use of small, rapid discharges to break up mineral deposits within the human body (such as kidney stones) without the use of surgery. I would not recommend that you try to directly replicate this one. However the effect can be demonstrated in your water tank by using bits of sedimentary rock or plaster.

Früngel's book mentions a number of other applications for underwater sparks ranging from sonar to milking machine sterilization. An interesting topic for study is the effect of underwater shocks on plant seeds. Faster growth rates have been observed for seeds exposed to moderate, multiple shocks (per Früngel, 10 to 40 shocks with the seeds at a distance of 5 cm from the gap; energy supplied by at 0.2 μ F capacitor at 8 kV). Higher energies and closer seed to gap distances were found to have destructive effects on the seeds.

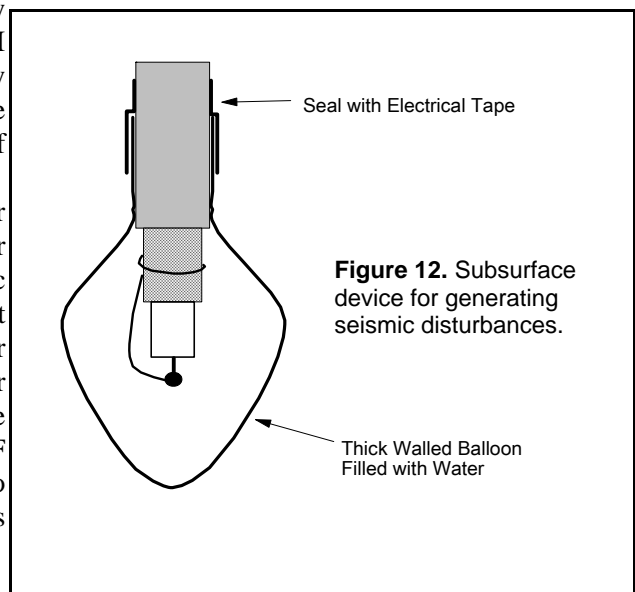

Figure 12. Subsurface device for generating seismic disturbances.

To conclude, the exploding wire represents an interesting and complex phenomenon. With some relatively simple apparatus, the dedicated amateur experimenter can undertake a wide variety of investigations, only some of which have been touched on here. Please feel free to contact the author with your questions, comments, or ideas for further work in this fascinating area.

REFERENCES

[1] W.M.Conn, *Combination of electrically exploded wires and electric arc*, in “Conference on Extremely High Temperatures” (John Wiley & Sons, NY, 1958).

[2] Frank Früngel, *High Speed Pulse Technology*, Volume 1 (Academic Press, NY, 1965). Dr. Früngel’s book includes the text of reference [1]. I would strongly recommend this book as basic, required reading for anyone desiring to work with high voltage pulse apparatus and phenomena. Covered in the volume are capacitors, switching means (thyratrons, spark gaps, ignitrons, etc.), line conductors, high current impulses, high voltage impulses, x-ray and neutron sources, generation of high temperatures, pulsed magnetic fields, acoustic impulses, and capacitor discharges for material working (e.g. spark erosion). A second volume, also published in 1965, concentrates on flash illumination and pulse measurement. With an emphasis on technique, these volumes are very applicable to the type of experimentation that may be undertaken by the dedicated amateur.