

Oct. 18, 1966

K. R. LEWIS ET AL
GRENADE LAUNCHER

3,279,114

Filed Sept. 25, 1964

4 Sheets-Sheet 1

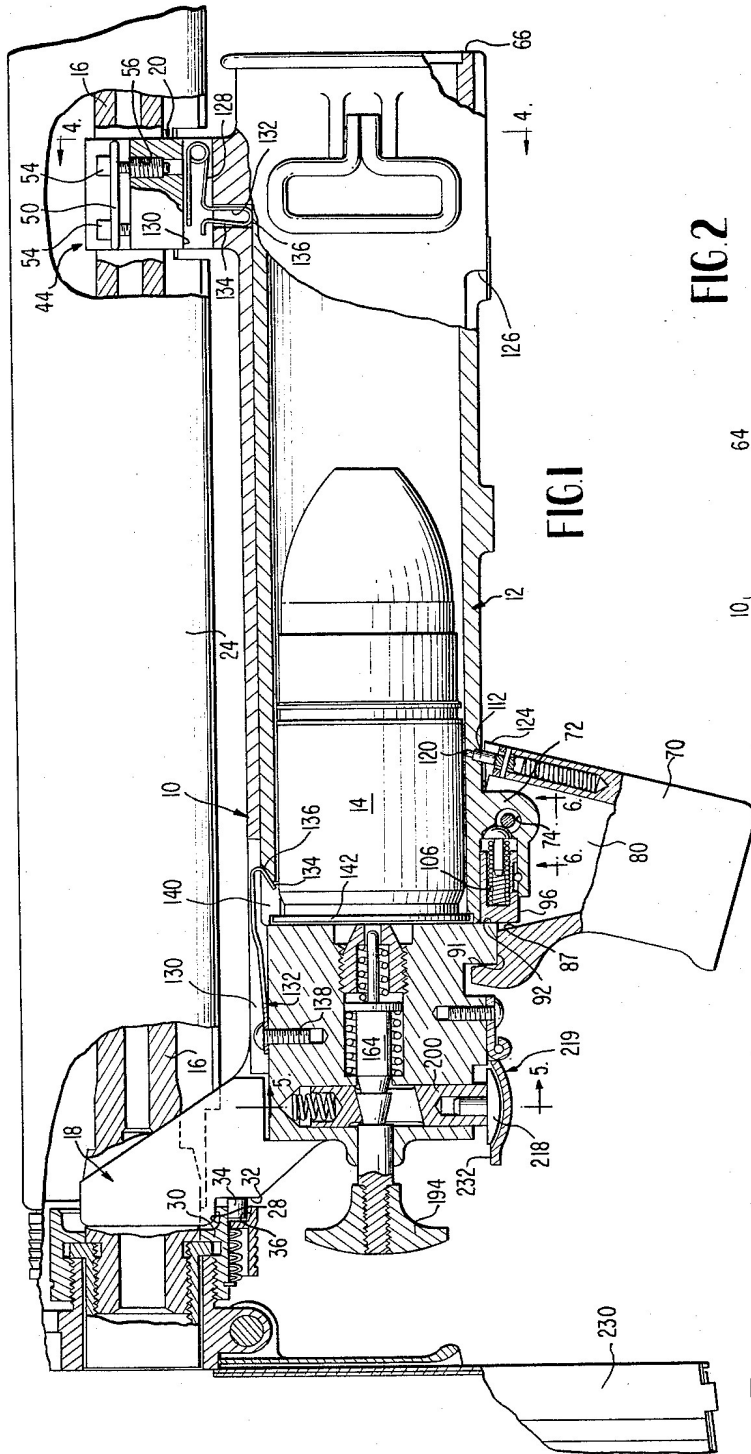
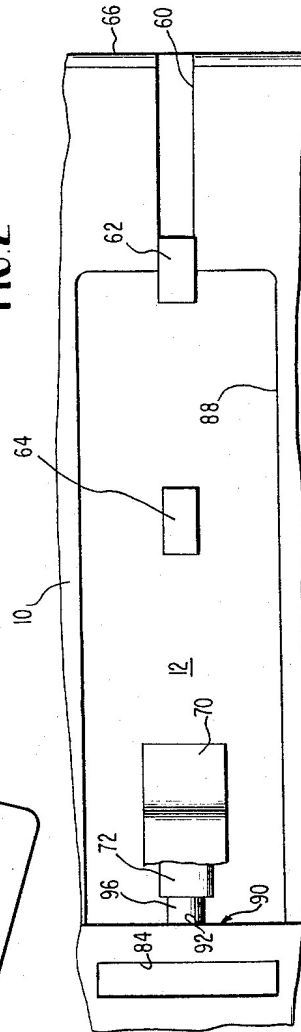

FIG. 1

FIG. 2



INVENTORS
KARL R. LEWIS
ROBERT E. ROY

BY *Lindsay Prutzman and Hayes*
ATTORNEY

Oct. 18, 1966

K. R. LEWIS ET AL

3,279,114

GRENADE LAUNCHER

Filed Sept. 25, 1964

4 Sheets-Sheet 3

FIG 3

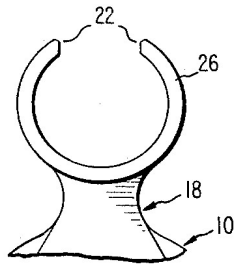

FIG 4

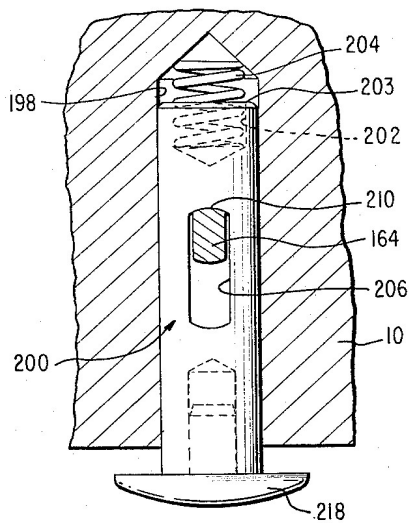
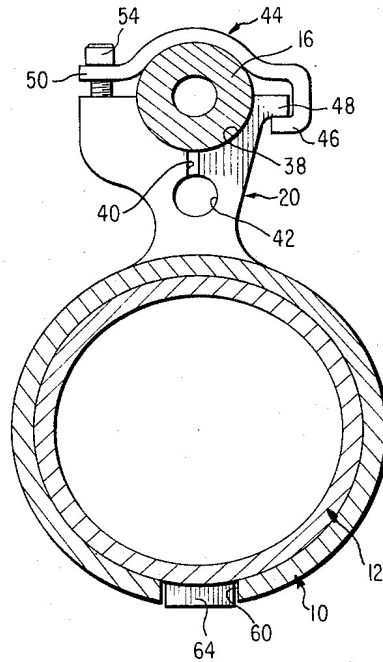

FIG 5

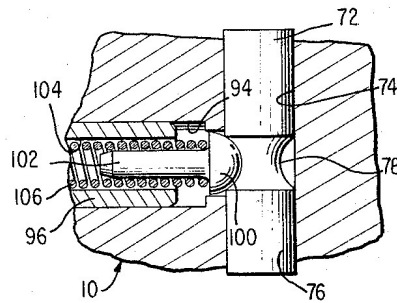

FIG 6

INVENTORS
KARL R. Lewis
ROBERT E. ROY
BY *Lindsay, Prutzman and Hayes*
ATTORNEY

1

3,279,114

GRENADE LAUNCHER

Karl R. Lewis, Weathersfield, and Robert E. Roy, East Haven, Conn., assignors to Colt's Inc., Hartford, Conn., a corporation of Arizona
 Filed Sept. 25, 1964, Ser. No. 401,761
 22 Claims. (Cl. 42-1)

This invention relates to a grenade launcher and more particularly to a grenade launcher which may be readily attached to the barrel of a conventional, small caliber rifle, allowing independent rapid firing of grenade cartridges accurately over relatively long range without interference with the normal rifle operation.

There is a present need for a lightweight, inexpensive launcher for grenades of the cartridge type, which may be easily and quickly mounted on the barrel of the standard military rifle, which will operate as a rapid firing weapon, and which is adaptable for projecting smoke and gas shells of similar construction. Since the weapon is to be used in conjunction with a standard infantry rifle, it must not add appreciably to the over-all weight of the rifle-launcher combination and must be easy to manufacture, assemble and maintain and at the same time, be capable of projecting the grenade at a relatively extensive range with extremely high accuracy.

Launcher attachments have been developed which utilize the gas pressure developed by firing of a blank cartridge within the rifle barrel itself for propelling the grenade in a somewhat inaccurate manner and over a relatively short range. It is obvious, that with launcher attachments of this type, the rifle and launcher may not be used contemporaneously but rather, the attachment of the launcher prevents the rifle from being used in a normal manner. Attempts have been made to produce a launcher-attachment which makes use of mechanical means for ejecting or propelling a grenade in cartridge or other form. The mechanical means in most cases consists of a high energy coil spring which is first compressed and then released to eject the cartridge through an associated barrel. Again, these launcher attachments fail to provide the necessary propellant force to deliver the grenade at the range desired, and have the further disadvantage of being highly inaccurate.

It is, therefore, a primary object of this invention to provide a grenade launcher which may be readily and easily attached to a conventional small caliber rifle which does not add appreciably to the over-all weight of the weapon combination, comprises a minimum number of operational parts, and is easy to manufacture and assemble.

It is a further object of this invention to provide an improved launcher of this type which is constructed of materials of high durability and requires relatively low maintenance.

It is the further object of this invention to provide an improved launcher of this type having a positive firing system with full automatic safety provisions.

It is a further object of this invention to provide an improved launcher of this type which includes a barrel assembly, including a pair of concentric cylinders in which a single movement therebetween effectively performs the dual function of loading of the cartridge and locking of the barrel.

It is a further object of this invention to provide an improved launcher of this type which may be readily attached to the rifle in a minimum time period, and which launcher will be retained regardless of shock and impact to which the launcher-rifle combination may be subjected.

It is a further object of this invention to provide an

2

improved launcher of this type having a positive operating firing system employing manually operable firing means carried by the launcher itself.

Further objects of this invention will be pointed out in the following detailed description and claims and illustrated in the accompanying drawings, which disclose, by way of example, the principle of this invention and the best mode which has been contemplated of applying that principle.

In the drawings:

FIGURE 1 is a slide elevational view, partially in section, of one embodiment of the grenade launcher of the present invention attached to a conventional small caliber rifle.

FIGURE 1a is an enlarged, side elevational view, partially in section, of a portion of the apparatus shown in FIGURE 1.

FIGURE 2 is a bottom plan view, of a portion of the launcher-attachment of FIGURE 1 showing the guide means for facilitating rectilinear movement between the concentric barrel and housing members.

FIGURE 3 is a rear elevational view taken along lines 3-3 of FIGURE 1 showing the position of the rear mount with respect to the rifle barrel when the launcher is secured thereto.

FIGURE 4 is a front elevational view of a portion of the apparatus shown in FIGURE 1 taken along lines 4-4 showing a method of clamping the front mount to the barrel of the rifle.

FIGURE 5 is a rear elevational view of a portion of the apparatus of FIGURE 1, showing in particular the relationship of the sear and the firing pin, taken along lines 5-5 of FIGURE 1.

FIGURE 6 is a plan view, in section, of the grip pivot pin and its method of attachment to the launcher barrel.

FIGURE 7 is a side elevational view, partially in section, of a second embodiment of the present invention showing a modified form of the firing control system.

FIGURE 7a is an enlarged, side elevational view, partially in section, of the trigger assembly shown in FIGURE 7.

FIGURE 8 is a rear elevational view taken along lines 8-8 of FIGURE 7 showing the firing control linkage.

FIGURE 9 is a side elevational view, partially in section, of the firing pin assembly taken along lines 9-9 of FIGURE 8.

In general, the present invention is directed to a grenade launcher of the type readily attached to a small caliber rifle. The launcher comprises a generally cylindrical housing having a longitudinal bore formed therein and a cartridge loading hole formed intermediate of the ends. A cylindrical cartridge receiving barrel is positioned concentrically within the housing bore for rectilinear movement from a first, retracted, locked position to a second, extended position exposing the cartridge loading hole. A grip member is pivotably coupled to the barrel and a forwardly directing force on the grip pivots the grip, simultaneously unlocking the barrel from the housing and moving the barrel forwardly to expose the cartridge loading hole. Friction means prevent free movement between the barrel and the housing. The housing includes a breech face at the rear of the cartridge loading hole and a firing pin receiving bore extends rearwardly from the breech face within the housing pin includes a pair of spaced sear latching ledges and a sear member is positioned at right angles to the firing pin within the housing with means tending to bias the sear into engagement at the ledge points. A main spring tends to bias the firing pin toward firing position and a rebound spring acts oppositely thereto. A sear button extends exteriorly of the housing for

manual release of the firing pin under the biasing means, in a first embodiment. A spring-biased cover prevents inadvertent firing of the cocked weapon. A manually operated button is coupled to the firing pin for moving the pin into cocked position against the main spring bias.

A simplified mounting arrangement is provided including spaced front and rear mounts for quickly and securely mounting the launcher to a conventional small caliber rifle. In the a second embodiment, a trigger member is positioned adjacent to the rifle trigger and linkage means couple the trigger to the sear for moving the sear to released position against the sear basis.

Referring to the drawings, the improved grenade launcher of the present invention which is most advantageously used as an attachment to a conventional small caliber rifle, comprises two main elements, a generally cylindrical housing member 10 which acts to support an inner, longitudinally slidable barrel 12 which is concentric hereto and adapted to move from a rear or locked position to a forward or open position for allowing the manual loading of a grenade-cartridge 14 of conventional construction. The launcher is attached to the rifle barrel 16 through the use of a rear mount member 18 and a front mount member 20, both mounts being integrally formed or fixed to the housing 10. It might be stated that all of the elements of the launcher-attachment assembly are formed of relatively lightweight metal with minimum precision finish to facilitate mass production of relatively simplified design, in which a great number of the parts perform double duty functions. The rear mounting member 18, FIGURE 3, is generally U-shaped in cross-section and forms an open slot 22 at the top, the width of the slot 22 being slightly in excess of the smallest diameter of the rifle barrel 16. The outer surface of the rifle barrel, of course, tapers from front to rear, with the integral, one-piece U-shaped mount 18 being slid over the barrel 16 under the conventional hand guard 24 such that the arms of the rear mount 18 encircle the barrel. The launcher is then slid rearwardly until the rear face 26 of the rear mount 18 contacts a grooved surface 28 of a conventional thread nut member 30 associated with the rifle barrel assembly. The configuration of the contact surfaces of the rear mount may, of course, be modified to meet the requirement of any particular rifle with which the launcher-attachment is to be used. In order to positively locate the launcher circumferentially with respect to the barrel 16, the rear mounting member 18 may be provided with an offset rear surface 32 which may have positioned thereon, a mounting pin 34 adapted to seat within a specially formed pin recess 36 associated with the rifle itself. After the launcher assembly has been slid rearwardly with the arms of the rear mount 18 embracing the rifle barrel 16 and after pin 34 is seated within its locating recess 36 with the face 26 of the rear mounting member abutting nut 30, the front mounting member 20 is positioned in contact with the front end of barrel 16 in the manner indicated in FIGURE 4.

FIGURE 4 shows in cross-section a portion of the housing 10 including the formed lower mounting member 20, the mounting member having a concave opening 38 receiving the lower surface of barrel 16. The front mount 20 includes a longitudinal slot 40 and a longitudinal bore 42 acting to split the lower mount 20 and giving it some resilience. An upper clamp 44 is generally U-shaped in cross-section and has, in addition, a latching extension 46 which extends down, over and under cooperating flange 48 of mount 20 with the flange 48 acting as a pivot. The other end of the U-shaped clamp 44 has a cooperating flange 50 which receives two spaced bores 52, the bores receiving independent screw members 54. In like manner, the opposing mounting member 20 is threaded at 56 such that rotation of the screw members 54 tends to pivot the upper clamp 44 about flange 48 to securely lock the front mount 20 to the rifle barrel 16. The position of the longitudinal slot and aperture 40 and 42 respectively allows

the mount to be used with rifle barrels of generally the same outside diameter, but differing slightly in diameter.

The use of the simplified clamping arrangement in which only two screws hold the launcher-attachment onto the rifle barrel, permits the launcher-attachment to be completely attached to the rifle in about 45 seconds. The rear mount 18 transfers the launcher recoil to the rifle while the front mount 20 merely holds it in place. In this respect, the provision of slot 22 across the top of the rear mounting member 18 reduces the total holding area or contact area between the rear mount and its associated nut 30 only about 20% and does not materially affect the ability of the rear mount 18 to transfer the full recoil of projectile 14 firing from the launcher to the rifle. While the launcher is preferably designed for attachment to a conventional small arms rifle, the simplified coupling attachment using front and rear mounting members allows the launcher to be readily coupled, in a quick and efficient manner, to weapons other than small arms and may, in fact, be readily attached to any appropriate supporting member.

The concentric barrel and housing arrangement allows maximum surface contact between the relatively moving members during ejection of a used cartridge shell and replacement of a fresh grenade-cartridge. In this respect, the cylindrical housing 10 is provided with a longitudinal groove 60 at its forward and bottom end, see FIGURE 2, the groove 60 acting to receive a forward barrel lug 62 which is integrally formed with the barrel. The lug comprises a rectangular extension which projects radially outward from the cylindrical surface of the barrel. The barrel lug 62 is of a width approximating groove 60 and acts to guide the barrel in its rectilinear movement with respect to the cylindrical housing 10. A second barrel lug 64 is positioned to the rear of the first lug 62, in line therewith, and is of equal dimensions. It is apparent that when the cylindrical barrel 12 is in its forward position, the lug 62 will have moved out of the groove 60 at the forward end 66 of the assembly, and the rear lug 64 will then have moved into the groove 60 to retain proper circumferential positioning of the barrel with respect to the concentric housing. Of course, instead of a pair of spaced barrel lugs 62 and 64, a continuous ridge might be used. However, for purposes of providing as light a weapon as possible, the spaced lugs are preferred.

In order to load the weapon, the barrel must be moved from the rearmost position shown, to a fully open or forward position. In order to accomplish this, the apparatus of the present invention makes use of a single grip member 70 which performs the dual function of locking the barrel in its fully closed operative position to the housing and at the same time provides the means to manually move the barrel relative to the housing. The barrel 12 includes a radial, depending lug 72, formed integrally therewith. The lug 72 includes a transverse bore 74, the bore 74 receiving a cylindrical grip pivot pin 76. The pin has a reduced cross-sectional portion 78 formed intermediate of the ends. The grip 70 may be formed of cast metal and has a hollow interior 80 with an open upper end 82 to receive lug 72. The grip further includes aligned openings (not shown) on opposite surfaces of the grip through which the free ends of the pin 76 project for the purpose of pivoting the grip about lug 72, while allowing removal therefrom.

Housing 10 includes a recess 84 which receives a grip locking lug 86 when the grip is pivoted clockwise about the grip pivot pin 76. It is thus apparent that the grip, since it is pivotably fixed to the barrel 12 and since it includes a locking lug 86 which is received within recess 84 of the barrel, will act to lock the barrel 12 in the rearmost position with respect to the housing 10 in a simplified and expedient manner.

The cylindrical housing 10, of necessity, includes a relatively large opening or cartridge receiving hole 88 which is really an extension of groove 60 on the under-

5

surface thereof to allow the insertion of a grenade-cartridge within the barrel when the barrel 12 is moved forward. Opening 88 terminates at the rear, adjacent breech face 90, the opening 88 being rectangular in configuration. The diameter of the breech face is somewhat larger than the diameter of the barrel so as to provide a contact edge 92 centrally of the hole 88. The depending barrel lug 72 includes a longitudinal bore 94 which receives a cylindrical grip plunger 96, the diameter of the plunger 96 closely approximating the diameter of bore 94. The bore 94 terminates adjacent transverse bore 74. A semi-circular recess 98 connects the transverse bore 74 and the longitudinal bore 94 and acts to receive the head 100 of grip pivot pin retaining plunger 102. The grip plunger 96 is provided with an inner bore 104 which receives a coil spring 106, one end of which is seated within the bore 104 and the opposite end acts upon the shoulder 100 of the grip pivot pin retaining plunger 102. The stem of the retaining plunger 102 is positioned coaxially within the coil spring 106 and the bias of the coil spring tends to position the head 100 of the retaining plunger in contact with the reduced cross-sectional portion 78 of the grip pivot pin 76.

In addition, the grip plunger 96 has formed therein a groove 108 which extends partially along the outer surface of the plunger. A retaining pin 110 is fixed to the lug 72, is positioned within the groove 108, and tends to limit forward and reverse movement of the grip plunger as it moves longitudinally within the bore 94. The coil spring 106 then acts as a common bias for both the grip pivot pin retaining plunger 102 and the grip plunger 96. The grip 70 is removable from the barrel 12 by the simplified operation of removing the grip pivot pin 76, this transverse movement of the pin being of course resisted by the spring biased grip pivot pin retaining plunger 102.

As mentioned previously, in order to automatically eject a used cartridge shell and to allow manual loading of a new cartridge, the barrel is moved rectilinearly with respect to the housing 10. Such movement is prevented by grip locking lug 86 being positioned within the recess 84 of the housing 10. However, by pivoting the grip 70 counterclockwise about grip pivot pin 76, the grip locking lug will free itself of the recess 84 and slide over radial face 91 of the housing.

The grip 70, when pivoting counterclockwise about the pivot pin 76, will be opposed somewhat by the cartridge retainer plunger 112. The grip 70 is bored at 114 to receive the cartridge retainer plunger 112 which is guided for longitudinal movement within the bore 114 by a slotted transverse guide member 116. Upon removal of the grip 70 the guide pin 116 coacts with the flared rear portion of plunger 112 for retaining the plunger within bore 114. The rear face of the cartridge retaining plunger is positioned against a coil spring 118, the bias of the coil spring tending to force the cartridge retaining plunger out of the bore 114 with the tip 120 passing through a cooperating cylindrical opening 122 within the barrel 12 and against the side of cartridge 14. Thus, as the grip 70 is pushed forward, it pivots counterclockwise around the pivot pin 76. The forward pressure on the grip causes the grip locking lug 86 to move outward (down) from the opening or recess 84 in the housing 10, resisted by the bias of spring 118 and the barrel now telescopes forwardly with the lugs 62 and 64 acting as guide means. At this moment, the grip plunger 96 under the bias of spring 104 moves rearwardly and the face 97 of the grip plunger contacts the ledge 87 of the grip. Continued manual pressure on the grip 70 telescopes the barrel until the grip face 124 hits the face 126 at the bottom of the housing.

In order to prevent accidental return of the barrel from a forward to a rear or closed position prior to loading of the cartridge, frictional means are provided for retaining the barrel in any longitudinal position. A simplified method of accomplishing this purpose is achieved through the use of a barrel friction spring 128 which is seated

6

within a specially formed longitudinal opening 130 of the housing and vertical opening 132 which is at right angles thereto. The barrel friction spring 128 includes a depending U-shaped portion 134 which has a contact surface 136 contacting the top of the barrel 12, the presence of the barrel tending to contract the spring. The spring force developed is sufficient to hold the barrel 12 in any position longitudinally with respect to the housing 10. For instance, if the barrel is in the fully opened position, and the rifle-launcher assembly were tilted upwardly at say perhaps 45°, there would be a normal tendency for the barrel to move rearwardly under the force of gravity. The presence of the barrel friction spring overcomes this tendency and the barrel must be manually moved from the front to the rear position. With the barrel friction spring 128 exerting the pressure against the barrel, the hand normally used in moving the grip and associated barrel forward is free to insert a cartridge into the barrel chamber. There is now an exposed opening 88 at the bottom of the housing which permits the cartridge to be inserted into the barrel. The grip 70 is held in the open position by the grip plunger 96 which protrudes outwardly from its bore 94 under the bias of compression spring 106.

After manual insertion of the cartridge 14 within the barrel 12, the cartridge will be retained in the chamber through the use of the cartridge retainer plunger 112, the head 120 of the plunger being forced against the surface of the cartridge 14 and frictionally holding it in position within the barrel by the action of coil spring 118. Thereby, spring 118 ensures the proper position of the cartridge retainer plunger 112 to provide the friction grip between the cartridge and the barrel. With the cartridge frictionally retained, the operator is again free to now grasp the grip 70 regardless of the incline of the weapon combination. A rearward pull on the grip 70 will cause the barrel 12 to overcome the friction of the barrel friction spring 128. During loading the grip plunger 96 is lodged against locking lug 86 under the bias of compression spring 106. At the moment that the locking lug 86 clears the ledge 91, the grip plunger 96 hits the edge 92 and telescopes back into aperture 94 of the lug 72. Grip 70 is free to pivot clockwise and continued pressure on the grip causes it to come into the locked position with the grip locking lug 86 received within recess 84 of the housing. At the same time, the grip is held in its clockwise and locked position by the bias of compression spring 118 acting on the cartridge retaining plunger 112.

The housing 10 has another recess 130 on its upper face, in front of the rear mounting member 18. This recess receives an extractor in the form of a leaf spring 132, the leaf spring having a downwardly and rearwardly curved frontal portion 134 which abuts against the tapered rear surface 136 of the barrel 12. The extractor 132 is fixed at the rear by a conventional threaded screw 138, the screw being received in a threaded bore within the housing 10. The barrel 12 includes a cooperating recess 140. The cartridge 14 is provided with a conventional cartridge rim 142 which is of a slightly greater diameter than the diameter of the main cartridge body and is received within recess 144 of the barrel 12. Upon rearward movement of the barrel 12 with the cartridge 14 in place, the cartridge rim 142 rides over the tapered surface 134 of the extractor. After firing, and upon forward movement of the grip 70, there is a tendency to carry the extended cartridge along with the barrel 12. As the barrel and cartridge move forwardly, the cartridge rim 142 contacts the downwardly projecting spring arm 134 of the extractor momentarily restraining the expended cartridge shell. As the barrel 12 continues to move forwardly, the expended cartridge falls through the opening 88 by gravity prior to the manual loading of a fresh cartridge. The rearwardly inclined terminal portion 134 of the extractor also serves another function. At the

time of closing of the barrel to battery position, the extractor 132 which has passed over the cartridge rim 142 comes to rest firmly against the inclined surface 136 of the barrel. The purpose of this is to cause the extractor, which is really a strong leaf spring, to exert pressure downwardly and thus cause the barrel to come to rest in battery position at the exact same place every time. Thus, the extractor 132 cooperates with the barrel friction spring 128 to securely position the barrel in the same position for each cartridge firing, and in theory, cartridge impact at the target will be the same, all other things being equal.

An important feature of the present invention resides in the firing mechanism. The firing mechanism is positioned concentrically of the housing within the breech block immediately behind the grip. A longitudinal bore 150 is provided centrally of the housing, extending from the rear housing surface 152 to the breech face 90. The bore 150 includes a forward threaded portion 154 which receives an annular threaded recoil plate 156. The annular plate 156 includes a forward, relatively small diameter bore 158 and a rearwardly disposed counterbore 160. The small bore receives the nose 162 of firing pin 164, while the larger bore houses rebound compression spring 166. The rear end of the recoil plate includes a recoil plate face 168 which is normally spaced from the opposed firing pin face 170 by compression spring 166. The firing pin face 170 is formed by enlarged annular portion 169 of the firing pin 164 of slightly less diameter than the diameter of the main section of the bore 150. The firing pin is further characterized in a reduced cross-sectional portion 172 immediately behind the firing pin face 170 with a main compression spring 174 positioned thereabout. The compression spring tends to force the firing pin forwardly causing the nose 162 to strike the rear surface of the cartridge. The compression spring abuts the shoulder produced by annulus 169 and a shoulder 180 formed by reduced bore section 176 of the housing. The firing pin is further characterized by a first inwardly tapered ramp 182, and a second inwardly tapered ramp 184, thus forming a ledge or shoulder 186 therebetween. The inwardly tapering ramp 184 forms a ledge or shoulder 190 spaced rearwardly of shoulder 186. The terminal pin section 188 is positioned within a coaxial housing bore 192. The firing pin is moved outwardly of respective bore sections against the bias of main compression spring 174. A button 194 is threadably attached at 196 to the rearwardly projecting terminal portion of the firing pin 164.

A bore 198 of uniform diameter is formed within the rear of housing 10 at right angles to the firing pin bore 150, and receives a cylindrical sear 200. The sear 200 is provided at the inner end with a central recess 202 within which is positioned compression spring 204, the inner end of which seats at the bottom of bore 198. The cylindrical sear 200, as seen in FIGURE 5, includes a rectangular central aperture 206 through which passes the firing pin 164. The recess 206 is rectangular in cross-section and is diagonal, thereby providing an upper tapered sear contact surface 208 terminating in a sear edge 210, the sear edge tending to position itself adjacent shoulder 190 or 186 depending upon the longitudinal position of the firing pin 164. The outer end 212 of the sear projects beyond bottom wall 214 of the housing 10 within recess 216. The sear includes a button 218 affixed thereto, the button moving with the sear and acting to compress the biasing spring 204 to release the firing pin 164 when it is cocked. In order to prevent inadvertent firing, a safety hinge 219 has one end 226 fixed to the housing by screw 220. The other end 228, which is concave, acts to cover the sear button 218. A spring 224 is secured at one end to the fixed portion 226 of the hinge assembly while the other end is affixed to the pivotable cover 228. The spring 224, therefore, tends to keep the cover in a closed position in line with the fixed

end 226 unless the cover is pivoted counterclockwise against the spring bias.

The firing pin 164, as shown, is in a neutral position. The main spring 174 is exerting no pressure. The rebound spring 166 is pushing rearwardly at one or two pounds pressure so that the firing pin nose 162 will not be exposed, being fully protected within bore 158. The bias of the rebound spring is also sufficient to push the firing pin 164 rearwardly to the extent that sear edge 210 will be positioned within the notch formed by shoulder 190. The positioning of sear edge 210 in front of shoulder 190 will keep the firing pin from moving forward and accidentally firing a cartridge if firing pin button 194 should receive a blow.

In order to fire the launcher cartridge, the button 194 is pulled rearwardly causing firing pin 164 to move rearwardly against the bias of the main compression spring 174. (If the operator's fingers should slip off the button before the sear 200 reaches the cocking notch formed by shoulder 186, the sear under the bias of compression spring 204 will ride down on ramp 184 and being in line with shoulder 190, the sear edge 210 will stop forward movement of the firing pin and the cartridge, of course, will not fire.) Continued rearward manual movement of the button 194 will cause the sear 200 to climb the ramp 184 and as soon as a notch formed by shoulder 186 clears the sear edge 210, the sear will drop onto ramp 182 and the firing pin button 194 may be released with the firing pin 164 remaining cocked.

The enlarged button 218 provides a large surface to push against to fire the launcher. The safety hinge which normally protects the cocked sear from being accidentally fired is rotated counterclockwise against the biasing spring. To fire the launcher, the operator may rest the palm of his hand against the gun at the clip area indicated at 230 and with his forefinger, push against the outer ledge 232 of the safety hinge 220. The hinge will resistingly move out of the way of the finger, thus exposing the button 218 for actuation of the sear 200 to effect release of firing pin 164. The firing pin 164 moves forward, overcoming the bias of the rebound spring 166 and the nose 162 will protrude past the breech face 90 and fire the cartridge 14. Predetermined forward movement of the firing pin 164 is controlled by the firing pin face 170 and the recoil plate face 168. The firing pin 164 will rebound as the result of impact. However, the rebound spring 166 which is compressed during this forward movement will make sure that the firing pin will rebound sufficiently to permit the spring-biased sear 200 to automatically lodge itself in front of the firing pin ledge 190.

In firing the weapon, push button 218 is moved inwardly, which moves sear 200 within the bore 198, thus releasing the firing pin. Overtravel is prevented due to the fact that the coil spring 204 is provided with a predetermined number of coils such that it will be compressed to solid height after sufficient movement of the sear pin to release the firing pin. Alternatively, the inner end 203 of the sear could bottom out against the bottom of the bore 198 to prevent trigger overtravel.

The firing pin and miscellaneous parts are installed through the breech face 90 of the main housing 10 and the recoil plate 156 is screwed into place. The button 194 is, of course, screwed on after the firing pin and associated mechanism has been installed. The sear 200 with its compression spring 204 is inserted into the bore 198 before insertion of the firing pin such that assembly in the order of FIGURE 5 is accomplished.

In the embodiment shown in FIGURES 1 through 6 inclusive, the firing system including the trigger is compactly incorporated at the rear of the launcher itself. In a second embodiment shown in FIGURES 7 through 8 inclusive, the grenade launcher is generally identical in construction to that of the first embodiment with the main exception of the firing system and in particular the trigger means. Referring to these figures in the drawings,

the grenade launcher again includes a cylindrical housing 10', a concentric, relatively movable barrel 12' with the housing 10' including a front mounting member 20' and a rear mounting member 18'. The launcher-attachment employs the identical, attachable grip 70' and is mounted for quick attachment-detachment to a conventional small caliber rifle in the identical manner as the first embodiment. The rear end of the launcher-attachment includes a main, longitudinally extending, central bore including a main section 150' which acts to receive a firing pin 164' which is generally the same as the firing pin of the first embodiment. Unlike the firing pin of the first embodiment, it is not semi-rectangular in cross-sectional configuration but is completely round. In addition, instead of the housing 10' being provided with a vertically extending second bore at right angles to the firing pin bore 150', the housing is provided with a horizontally extending bore 300 at right angles to the firing pin bore 150'. The bore 300 holds a rotatable sear 302 which includes a grooved central portion forming the sear edge 312 and reduced diameter end 304 which extends outwardly, away from the side of the housing 10'. By reference to FIGURE 8, it is seen that the housing 10' is cut away as at 306 to receive a sear lever 308 which is fixed to the protruding end 304 of the sear and is adapted to rotate therewith.

The method of cocking the firing pin 164' and its operation after firing is identical to that of the previous embodiment. As the button 194' is moved rearwardly, the firing pin 164' will move rearward resisted by main spring 174'. Continued rearward movement of the button 194' will cause the sear to rotate counterclockwise due to the inclined ramp 184', the rotation of the sear 302 being resisted by coil spring 310, FIGURE 7. The sear edge 312 will fall off of ramp 184' onto ramp 186' with the sear 302 rotating clockwise and the firing pin 194' may be released with the firing pin remaining in the cocked position as shown in FIGURE 9. The firing pin 164' moves forward under the bias of main spring 174', when fired, with the pin nose moving through recoil plate aperture 158' to detonate the charge within the cartridge 14'. The recoil plate 156' includes a counterbore 160' holding the recoil spring 166' which acts on the firing pin face 170' to move the firing pin 164' sufficiently to the rear to allow the biased rotating sear 302 to move its sear edge 312 into contact with safety notch 210'.

The principal difference in the firing system of the second embodiment resides in providing means whereby the launcher may be fired from approximately the same position as the rifle itself, that is, by means placed adjacent the conventional rifle trigger mechanism. The sear lever 308 has a pair of upwardly extending fingers 316 formed by a central, vertical slot 318, with the fingers 316 passing on each side of the trigger bar 320. The elongated trigger bar 320 is round in cross-section but is milled flat in the area of the sear lever 308 to form a loose but restrictive connection between it and the sear lever.

The trigger bar 320 extends rearwardly and downwardly adjacent magazine 230'. An S-curved section 326 is coupled to trigger 340 by a trigger support member 342. Opening 322 within housing 10' and trigger bar guide rod 328 act to position the trigger bar and attached trigger 340 for limited longitudinal movement.

Thus, the trigger 340 may be extended to the phantom view position 340'. The trigger support member 342 is cylindrical and includes a rear bore 343 of approximately the same diameter as the diameter of head 344 of the screw 338, FIGURE 7a. The trigger support bar has a front bore 346 of smaller diameter, approximately the same as the reduced cross-sectional portion 348 of the trigger bar 320. This provides a shoulder 350 intermediate of the two bore sections 343 and 346. Thus, the trigger may normally be positioned in the full line position shown but prior to operating the launcher, the trigger

340 is grasped and moved to the rear position 340' immediately adjacent the rifle trigger 314. In moving rearwardly, the operator must overcome the friction between head 344 of screw 338 and the enlarged bore section 342 of the trigger support member 340. This friction developed requires about 15 pounds' force to reposition the trigger from the phantom position 340' to the position 340 stowed adjacent the clip well 230' and vice versa. If the operator has mittens on and cannot conveniently grasp the trigger in the position shown at 340', the trigger may be rotated to the phantom position 340'', a full 180° rotation.

The trigger return spring 310 pushes the sear lever 308 forward and the sear lever being attached to the sear rotates the sear 302 clockwise into firing pin safety notch 210' automatically after firing due to action of rebound spring 166' in the manner explained in the earlier launcher description.

To fire the launcher of the second embodiment, the cocking button 194' is pulled rearwardly. When the cocking notch 186' clears the sear edge 312, the trigger return spring 310 pushing against the sear lever fingers 316 causes the sear 302 to rotate in front of cocking notch 186'. The button 194' may then be released and the launcher is ready to fire. A rearward pull on trigger 340 will pull the sear lever 308 to the rear, tending to rotate the sear 302 counterclockwise releasing the firing pin. The firing pin under the bias of main spring 174' will fire the cartridge. Rearward movement of the trigger 340 is controlled after the firing pin is released by the trigger return spring 310. The trigger return spring 310 is provided with a predetermined number of coils in the predetermined space between fingers 316 and the trigger bar guide rod 328, thus rearward movement of the trigger 340 is limited to the point where the spring 310 is compressed to solid height. This restriction of over-travel reduces jerking of the gun and increases accuracy. The firing pin will return to the neutral position by the pressure of the rebound spring 166' and upon releasing the trigger 340, the bias of the compressed coil spring 310 will cause the sear 302 to rotate into a position where a sear edge 312 moves into the safety notch 210'. Thus, the trigger system permits the operator to fire the launcher with the same hand that actuates the trigger 314 on the rifle. As is evident from viewing FIGURE 8, the rebound spring 166' remains within the bore 160' of the recoil plate 156'. This is achieved by making the innermost coil of the rebound spring 166' slightly larger in diameter than the diameter of the bore 160' so that the spring is forced into position and stays there. This feature may also be provided in the apparatus of the first embodiment.

In the previous embodiment, it was necessary to provide a pair of narrow guide lugs 62 and 64 for ensuring proper orientation of the barrel with respect to the housing during the reciprocating movement therebetween. In the second embodiment, the lugs have been removed. However, the problem of guiding the barrel remains, as the same telescoping motion is utilized in loading the weapon.

In like manner to the previous embodiment, the housing 10' at the forward end includes cooperating horizontal and vertical bores 130' and 132'. However, the top of the barrel is dissimilar in that a longitudinal slot 350 is provided running a predetermined length of the barrel, and a pin 352 having a diameter slightly less than the diameter of vertical bore 132 is provided within bore 132', the width of the slot 350 being slightly greater than the diameter of pin 352. A U-shaped spring 354 is positioned within the horizontal bore 130', the spring 354 having one end fixed to the pin 352. The U-shaped spring is compressed and thereby exerts a downward force upon the pin 352 effecting frictional engagement between the pin 352 and the bottom of the slot 350. Thus the pin 352

exerts a drag on the barrel and also tends to guide and position the barrel circumferentially during the reciprocating movement. Since the pin exerts a drag on the barrel, it causes the barrel to remain positioned in any position, especially when the barrel is fully extended, allowing the operator's hand to be free to load a cartridge into the chamber. At the end of the slot 350, the natural radial cutter run-out 356 permits the barrel to be removed from the housing merely by forcing the pin up and out of the run-out 356 against the bias of spring 354. The barrel 12' is just as easily inserted into the launcher housing 10' by the guide pin 352 sliding up the inclined plane 136', FIGURE 9, of the barrel.

From the above description, it is apparent that the apparatus of the present invention, in both embodiments, provides an extremely simple, light, compact and durable grenade launcher which may be readily coupled to a conventional small caliber rifle or the like which operates completely independent of the rifle but does not interfere in the normal rifle operation. The launcher-attachment has its own positive firing system with full automatic safety provisions and the launcher-attachment may be subjected to extreme shock with no danger of inadvertent firing even though the weapon is fully cocked. Both embodiments disclose a number of features which may be incorporated in other weapons not limited to grenade launcher-attachments. Thus, features having special application here, have general application to weapon systems, these features residing primarily in the simplified loading and locking technique, the removable dual function grip, the firing mechanism and the launcher-attachment means.

As will be apparent to persons skilled in the art, various modifications and adaptations of the structure above described will become readily apparent without departure from the spirit and scope of the invention, the scope of which is defined in the appended claims.

We claim:

1. A grenade launcher of the type readily attached to a small caliber rifle comprising: a generally cylindrical housing having a longitudinal bore formed therein, a cartridge loading hole formed within said cylindrical housing, a barrel, means for positioning said barrel concentrically within said bore, guide means for allowing rectilinear movement between said barrel and said cylindrical housing to expose the cartridge loading hole, and common means coupled to said barrel for moving said barrel forwardly to expose said cartridge loading hole and for simultaneously unlocking said barrel from said housing.

2. A grenade launcher of the type readily attached to a small caliber rifle comprising: a generally cylindrical housing having a longitudinal bore formed therein and a cartridge loading hole positioned therealong, a cylindrical, cartridge receiving barrel positioned concentrically within said bore, guide means for allowing rectilinear movement only between said barrel and said housing from a first retracted, locked position to a second, extended position whereby said cartridge loading hole is exposed, and common means coupled to said barrel and movable therewith for moving said barrel from said first position to said second position and for simultaneously unlocking said barrel from said housing.

3. A device as claimed in claim 2 wherein said housing further includes catch means positioned rearwardly of said cartridge loading hole, and said common means includes a grip member pivotably connected to said barrel for rotation about an axis at right angles to said barrel axis, latch means carried by said grip member whereby a forwardly directed force on said grip member results in pivoting of said grip member about the pivot axis releasing said latch member from said catch member while simultaneously moving said barrel forwardly with respect to said housing.

4. A grip assembly for use with a grenade launcher

having a pair of concentric cylinders, one of said cylinders forming a housing including a longitudinal bore, said other cylinder forming a cartridge receiving barrel positioned concentrically within said bore and movable longitudinally with respect thereto from a first retracted, locked position to a second, extended position exposing a cartridge loading hole within said housing, said hand grip assembly comprising: a grip member, means for pivotably mounting said grip member to one of said relatively movable cylinders for movement about an axis at right angles to the axis of said cylinder, catch means formed on said second cylinder member, latching means formed on said grip, biasing means tending to rotate said grip member about said pivot point so as to engage said latch means with said catch means, whereby direct force delivered to said grip member tends to rotate said grip member in the opposite direction about said pivot point to unlock one cylinder with respect to the other and allow rectilinear movement therebetween.

5. A device as claimed in claim 4 wherein a recess is formed within said grip member, a plunger positioned within said recess and means biasing said plunger in an extended direction toward said cylinder upon which the grip member is pivoted.

6. The device as claimed in claim 5 further including biasing means coupled to said cylinder carrying said grip member and normally engaging said other cylinder but operable upon rotation of said grip member about said pivot point to engage said grip member in its rotated position to retain said grip member in said position in opposition to said biased plunger carried within said grip member whereby when moving said one cylinder from extended to retracted position said latch means is free to move to latching position with respect to said catch means.

7. The device as claimed in claim 4 wherein said one cylinder member carrying said grip member includes a radial projection, a transverse bore formed within said projection means at right angles to the cylinder axis, a pivot pin passing through said grip member positioned within said bore allowing limited rotation of said grip member about said transverse pin axis, said pin including reduced cross-sectional portion, a second longitudinal bore extending away from said first bore at right angles thereto, a grip pivot pin retaining plunger positioned within said second bore and means for biasing the head of said grip pivot pin retaining plunger into engagement with said reduced cross-sectional portion of said pivot pin to normally prevent removal of said grip from said cylindrical member.

8. A device as claimed in claim 7 wherein said longitudinal bore within said projection further includes a grip plunger positioned therein concentric to grip pivot pin retaining plunger, said biasing means for biasing said grip pivot pin retainer into engagement with said reduced cross-sectional portion of said pivot pin also biasing said plunger in the opposite direction toward said grip latch means whereby, after said grip member rotates about said pivot pin in one direction from a locked to an unlocked position and said cylinders are free to move relative to each other, said plunger acts to prevent rotation in the opposite direction.

9. In a grenade launcher for ready attachment to a small caliber rifle, a generally cylindrical housing having a longitudinal bore formed therein and a cartridge loading hole positioned therealong, a cylindrical, cartridge receiving barrel positioned concentrically within said bore, guide means for allowing rectilinear movement of said barrel with respect to said housing from a first retracted, locked position to a second, extended position exposing said cartridge loading hole, an annular breech face formed within said housing member at one end of said cartridge loading hole with said cylindrical barrel abutting said breech face in said retracted, locked position, a longitudinal bore formed centrally of said housing and extending

13

rearwardly from said breech face, a firing pin positioned within said bore, means tending to bias said firing pin in a neutral position, sear means carried by said cylindrical housing adjacent said firing pin and cooperating therewith to hold said firing pin in cocked position against said biasing means and trigger means coupled to said sear and extending exteriorly of said housing at the rear end thereof, to allow manual relative movement of said sear with respect to said firing pin, thereby providing a positive firing system.

10. A grenade launcher of the type for ready attachment to a small caliber rifle comprising: a generally cylindrical housing having a longitudinal bore formed therein and a cartridge loading opening positioned therealong, a cylindrical cartridge receiving barrel positioned concentrically within said bore, guide means for allowing rectilinear movement of said barrel with respect to said housing from a first, retracted, locked position with the inner end of said barrel positioned adjacent to an annular breech face formed by said housing, to a second, extended position away from said breech face exposing said cartridge loading opening, a relatively small bore formed within said housing at the rear end thereof and extending away from said breech face, a firing pin positioned within said bore for movement from an outward, cocked position to an inward firing position in which the nose thereof contacts a cartridge positioned within said barrel, a main spring positioned within said bore concentric to said firing pin and tending to move said firing pin to firing position, a rebound spring spaced from said main spring, operatively positioned with respect to said firing pin and acting in opposition to said main spring, a first tapered ramp formed on said firing pin terminating rearwardly in a first ledge for holding said locking pin in cocked position, a sear including a sear edge positioned within said housing for relative movement into and out of locking engagement with said firing pin, a second inclined ramp on said locking pin rearward of said first tapered means and forming a second ledge therealong, the position of said second ledge being such as to prevent the firing pin extension from contacting the cartridge as a result of disengagement of said sear edge and said first ledge.

11. The device as claimed in claim 10 wherein said sear is spring-biased into engaging position with said firing pin and said sear further includes means extending away from said housing for manual movement of said sear against said bias to release said cocked firing pin for firing said launcher.

12. The apparatus recited in claim 11 wherein said means extending away from said housing comprises a sear button and said apparatus further includes a pivotable safety cover extending over said sear button, said safety cover being hinged to said housing, means for spring-biasing said hinge in covering position whereby manual rotation of said hinge cover away from said button acts to uncover said button for allowing manual access to said firing mechanism.

13. A positive firing system for a grenade launcher or the like including a cylindrical housing having a cartridge receiving chamber at the forward end and an annular breech face immediately therebehind, a firing pin receiving bore formed within said housing and extending from said breech face rearwardly, said firing pin bore including a first section of relatively small diameter, a second section of enlarged diameter, a third section of largest diameter, and a fourth section of intermediate diameter, a firing pin positioned within said bore including a pin nose of a diameter slightly less than the diameter of said first bore section, an enlarged annular section positioned within said third bore section of a diameter slightly less than the diameter of said third bore and a section extending rearwardly therefrom of reduced diameter, a main spring positioned within said third bore section, concentric to said firing pin and positioned behind said annulus, a rebound spring positioned concentrically of said pin nose

14

within said bore second section tending to move said firing pin rearwardly, said firing pin being tapered at two adjacent points to form inclined ramps terminating in ledges, a sear member positioned within said housing and having a sear edge movable into engagement with a selected ledge, means biasing said sear into engagement, means for moving said firing pin rearwardly against the bias of said main spring to latch said firing pin in cocked position, said rearward ledge tending to catch said sear upon accidental disengagement of said sear in said forward ledge to prevent inadvertent firing of said cartridge as a result of shock to said weapon.

14. A grenade launcher for ready attachment to a small caliber rifle comprising: a generally cylindrical housing having a longitudinal bore formed therein, a cylindrical, cartridge receiving barrel positioned concentrically within said bore, means for allowing rectilinear movement of said barrel with respect to said housing from a first, retracted, locked position to a second, extended position for exposing a cartridge loading hole, common means coupled to said barrel and movable therewith for moving said barrel from said first to said second position and for simultaneously unlocking said barrel from said housing, a positive firing mechanism carried by said housing including a spring-biased, manually movable firing pin having at least one sear cocking detent formed thereon, a sear member carried by said housing, means biasing said sear into firing pin engaging position to hold said firing pin in cocked position, a manually operable trigger for moving said sear in opposition to said bias for positively firing said weapon, said housing further including at the rear end thereof, a generally U-shaped rear mount having a contact surface at the rear thereof for positive contact with a portion of said barrel for limiting rearward movement, a front mounting member including a U-shaped barrel receiving notch, a clamp, said clamp and said front mount acting to embrace said barrel, and means for moving said clamp toward said front mount whereby said grenade launcher may be rapidly attached and detached from said rifle.

15. Attaching mechanism for attaching a grenade launcher or the like to a small caliber rifle having a longitudinally extending barrel including shoulder means at the inner end of said barrel of a larger diameter than the forward portion of the barrel, the attaching mechanism comprising: a rear mount coupled to said launcher and extending upwardly from the rear thereof, said rear mount of U-shaped cross-sectional configuration, slotted across the top, the width of said slot being in excess of the smallest outside diameter of said rifle barrel, said rear mount further including a flattened rear surface for engagement with the shoulder means formed on said rifle barrel, an upwardly extending front mount including a generally U-shaped portion opening upward to receive the forward end of said rifle barrel, a cooperating U-shaped clamp, means for pivotably attaching said clamp to said lower front mount, and at least one screw member coupling the opposite side of said upper clamp to said lower mount whereby said launcher may be easily attached to said rifle by first allowing said rear clamp to embrace the forward portion of said rifle barrel and longitudinally sliding said launcher rearwardly of said rifle until said rear mount contacts the shoulder means whereupon said front clamp is secured to said front mount.

16. A positive firing system for a grenade launcher of the type readily attached to a small caliber rifle, the grenade launcher including a cylindrical housing to be mounted on the rifle below the rifle barrel and including a section at the rear having an annular breech face adjacent the cartridge chamber, a bore formed within said housing extending rearwardly away from said breech face, a firing pin positioned within said bore, means tending to bias said firing pin into said firing position, a cocking ledge formed on said firing pin, a second bore formed transverse to the first bore, a rotatable sear positioned

15

within said bore and having a sear edge for movement into engagement with said cocking edge of said firing pin, means for manually moving said firing pin rearwardly against said biasing means and means tending to rotate said sear into engagement with said cocking ledge after cocking, and means coupled to said sear and extending exteriorly of said housing, said means adapted for manual rotation against said biasing means to rotate said sear and release said firing pin to fire the grenade launcher.

17. The firing mechanism as claimed in claim 16 further including a sear lever fixed to said rotatable sear and extending radially therefrom exterior of said housing, a trigger bar, means for positioning said trigger bar in juxtaposition to said sear lever, said trigger bar extending away from said sear lever toward said rifle stock and terminating in the vicinity of the rifle trigger assembly, a trigger member, means for coupling said trigger member to said trigger bar whereby movement of said trigger bar tends to rotate said sear lever about said sear against said biasing means to release said cocked firing pin.

18. The firing mechanism as claimed in claim 17 wherein said trigger member includes a cylindrical extension portion, one end of said trigger bar being received within said cylindrical extension portion and means for frictionally coupling said trigger bar to said cylindrical trigger extension, means allowing limited, longitudinal movement of said cylindrical extension whereby said trigger may be resistingly moved from a position adjacent said rifle trigger to a position displaced longitudinally therefrom.

19. The positive firing mechanism described in claim 18 wherein said trigger bar is coupled to said sear lever for longitudinal movement thereto but is prevented from rotation therewith.

20. A grenade launcher of the type readily attached to a small caliber rifle comprising: a generally cylindrical housing including a breech block and a longitudinal bore formed forwardly thereof, a cartridge loading hole formed within said housing with the rear end of the loading hole terminating adjacent the breech block, a cylindrical cartridge receiving barrel positioned concentrically within said bore, guide means for allowing rectilinear movement between said barrel and said housing from a first retracted position to a second extended position whereby said cartridge loading hole is exposed, means for locking the barrel to the breech block including a grip pivoted on said barrel so as to be movable in a releasing direction by a force in the direction to move the barrel away from the breech block toward said cartridge loading position, and manually operated firing means carried by said breech block.

21. A grenade launcher of the type readily attached to a small caliber rifle comprising: a generally cylindrical housing including a breech block having a longitudinal bore therein, and a longitudinal bore formed forwardly thereof communicating with the bore in said breech block, a cartridge loading hole formed within said housing

16

with the rear end of the loading hole terminating adjacent the breech block, a cylindrical cartridge receiving barrel positioned concentrically within said bore, guide means for allowing rectilinear movement between said barrel and said housing from a first retracted position to a second extended position whereby said cartridge loading hole is exposed, means for locking the barrel to the breech block and manually operated firing means carried by said breech block, said firing means comprises a firing pin positioned within said bore, means tending to bias said firing pin in firing position, a manually movable sear carried by said breech block, and means carried by said firing pin and cooperating with said sear to hold said firing pin in cocked position in opposition to said firing pin biasing means.

22. A grenade launcher of the type readily attached to a small caliber rifle comprising: a generally cylindrical housing including a breech block and a longitudinal bore formed forwardly thereof, a cartridge loading hole formed within said housing with the rear end of the loading hole terminating adjacent the breech block, a cylindrical cartridge receiving barrel positioned concentrically within said bore, guide means for allowing rectilinear movement between said barrel and said housing from a first retracted position to a second extended position whereby said cartridge loading hole is exposed, a vertical opening formed in said housing and a spring member is positioned within said housing having a portion spring-biased in contact with said barrel through said opening in said housing member whereby said barrel is frictionally prevented from free rectilinear movement with respect to said housing.

References Cited by the Examiner

UNITED STATES PATENTS

955,237	4/1910	Westcott et al.	42—1
1,240,068	9/1917	Lytton	42—69
1,278,027	9/1918	Saunders	42—1
1,948,511	2/1934	Coupland	42—1
2,140,945	12/1938	Swartz	42—1
2,335,299	11/1943	Moore	42—1
2,339,285	1/1944	Moore	42—1
2,397,572	4/1946	Weaver	42—1

FOREIGN PATENTS

948,756	1/1949	France.
1,347,952	11/1963	France.
371,716	4/1932	Great Britain.
336,586	2/1936	Italy.
27,923	4/1903	Switzerland.

BENJAMIN A. BORCHELT, *Primary Examiner.*

SAMUEL FEINBERG, *Examiner.*

R. V. LOTTMANN, *Assistant Examiner.*