

This is an excerpt from the book

Fireplace Mantels
by Mario Rodriguez

Copyright 2002 by The Taunton Press

www.taunton.com



Simple Federal Mantel

This mantel is typical of those found in many rural farmhouses in the early 19th century. Almost always made of wood and painted, the style was taken directly from classical architecture and imitated the design of basic shelter: columns supporting a beam and roof. The simple moldings and joinery indicate that it could have been built by a local carpenter instead of by a furniture joiner. But its simplicity doesn't diminish its appeal in any way. The mantel's flat relief and plain treatment perfectly frame the Federal-period hearth opening and provide a focal point for the display of

family possessions and a backdrop for social gatherings and important events. The mantel's design shows elegant proportion, restraint, and balance. And the simple moldings cast bold shadows that highlight its timeless appeal.

The federal mantel is structurally straightforward and can easily be built in a weekend. Three boards joined together with biscuits form the foundation, which is fastened to the wall. Plinth blocks (doubled-up 1-by stock) support the plain vertical pilasters, which support the horizontal architrave. Add a few moldings and the mantel shelf, and you're ready to paint.

Simple Federal Mantel

PROVING THAT SIMPLICITY DOESN'T PRECLUDE ELEGANCE, this mantel design is anchored by ideal proportions and perfect symmetry with the brick firebox opening it adorns. Built with readily available materials and moldings, it's easy to build as well.

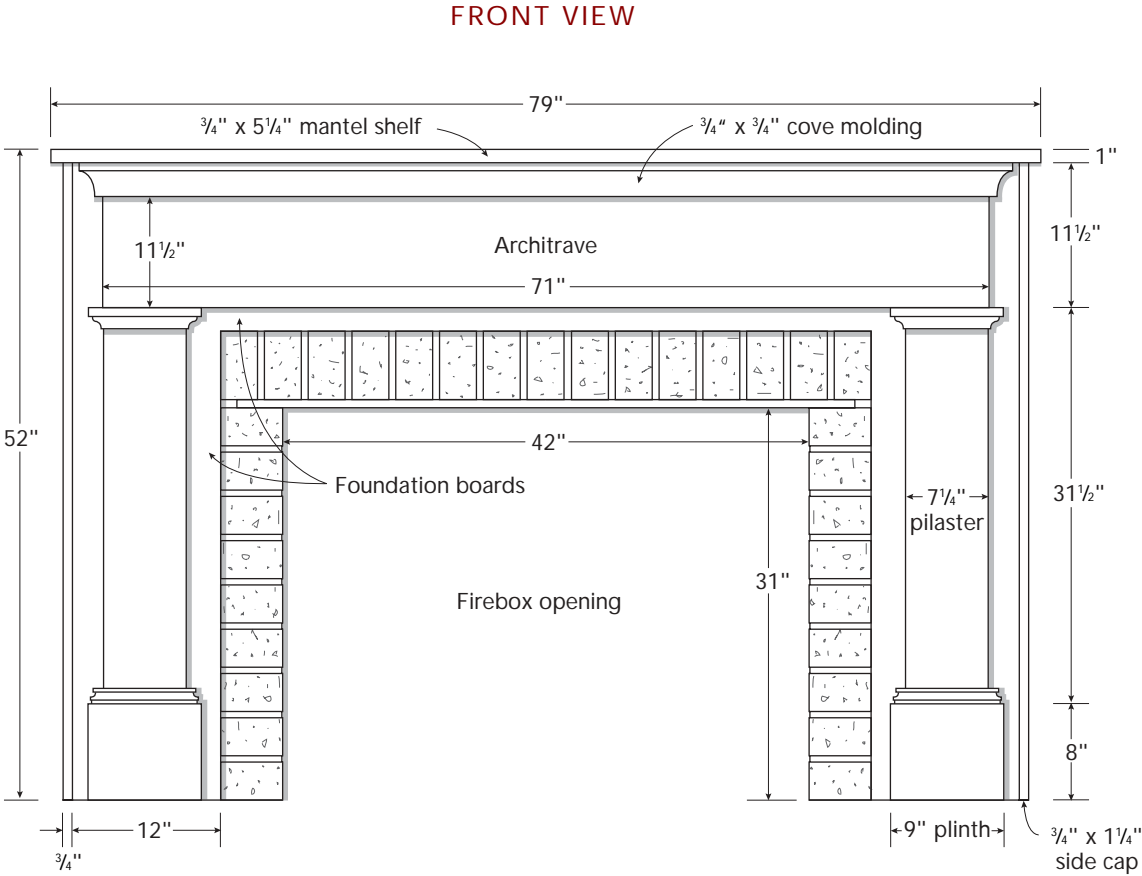

Building the Mantel Step-by-Step

Begin by preassembling the foundation board and laminating the plinth blocks, you can move directly to installation. I chose to preassemble some of the molding elements as well.

The Foundation Board

The foundation board is the backdrop of the mantel. It provides a flat surface for the mantel proper, and bridges any gaps or irregularities between the masonry and the adjacent wall surface, while exposing only the neatest brickwork. The mantel foundation was designed

with the lintel section fitting between the columns. That way the mantel parts would overlap the foundation joints, making the whole construction stronger.

1. Cut the two columns and lintel that will form the foundation. The firebox opening in this project is 32 in. high by 42 in. across, and an even course of bricks is left exposed around the sides and top. Using a 14-in.-wide lintel (horizontal section) and 10½-in.-wide columns (vertical sections) produced the balanced proportions that form the basis for the mantel's design. You should adjust these dimensions based on the size of your firebox opening.

Choosing Materials

During the 19th century, pine was abundant and readily available, and carpenters used it for most interior trim, including fireplace mantels. So a meticulous reproduction would require large, wide boards of clear pine. However, the use of solid pine for this project would present problems (besides price) for the modern woodworker that 19th-century carpenters weren't concerned with.

At that time houses weren't insulated, so warm and cold air passed through the structure freely. In a particular room, it wasn't unusual to experience surprising differences in temperature. With a fire blazing in the hearth, the warmest spot in the room would have been a seat in front of it, while other areas of the same room might be as much as 15° colder. These conditions surely played

havoc with human comfort but spared furnishings and interior woodwork from drastic changes in temperature and humidity. In a modern ultra-insulated home, wood is subjected to extremes of temperature and relative humidity created by efficient central heating and air-conditioning. The use of wide, solid boards and true period construction methods in a modern home would probably cause unsightly checking and splitting. Miter joints would likely open up, and flat sections would cup.

A better approach for today's woodworker would be to construct this mantel using lumbercore plywood instead of solid wood. I used ¾-in. lumbercore plywood for everything except the plinth blocks and the moldings. (See chapter 1, pp. 9–12, for a detailed discussion of materials.)

Join the foundation boards with a couple of biscuit slots.



Tip: You'd think pieces of molding stock at a lumber store are all identical. But if there are pieces from different batches, there could be slight differences, which will result in miters that don't line up perfectly. To avoid this, I try to cut all my mitered pieces from the same length of stock so there's no doubt that the profile is the same on all the pieces.

2. Lay out and cut biscuit joints to connect the lintel to the columns—three or four #2 biscuits should do the job.

3. Glue up the foundation assembly, making sure the columns are square to the lintel. When the assembly is dry, remove the clamps; but before moving it, attach two support battens across the front. The battens reinforce the joints, maintain the dimensions of the foundation opening, and keep it flat during installation.

The Plinth, Pilasters, and Architrave

Laminating the plinth blocks

The plinth blocks at the base of the pilasters are made with two pieces of $\frac{3}{4}$ -in.-thick solid pine laminated face-to-face. The net $1\frac{1}{2}$ -in. thickness is needed to support the pilaster and the plinth molding. You could use a chunk of 2-by stock, but the approach here resulted in a

more stable block, plus it made good use of scrap material I had on hand.

1. Cut the plinth block pieces slightly oversize.
2. Saw or rout two grooves into the back face of each piece, about $1\frac{1}{2}$ in. from the edges.
3. Fit a spline into each groove, and glue the mating surfaces together.

Cutting the parts to size

1. Arrange the main mantel parts (pilasters, architrave, and plinths) on the foundation.
2. Center the parts and cut them to length.
3. Cut biscuit joints to align the top of the pilasters to the architrave.
4. Cut the plinth blocks to size. (Depending on the condition of the hearth, you may want to leave the plinth blocks a little long so they can be scribed to the hearth at installation.)

Selecting the moldings

I purchased stock moldings from the local building supplier. The simple profiles I needed were readily available, in quantity. By choosing



Laminating two pieces yields a more stable plinth block. A pair of splines keeps the pieces from sliding around when clamping up.

available profiles instead of choosing special-order profiles, I could pick through the inventory and select the straightest and cleanest material.

There were three distinct profiles I needed: a large and simple cove for the cornice molding, an ogee with fillet for the torus molding (at the base of the pilaster), and a large ogee with quirk (space or reveal) for the capital molding. These last two moldings are both sold typically as “base cap” profiles.

Priming the parts

To achieve an attractive painted surface, the wood components must be carefully prepared. This involves filling any holes and dents and repairing cracks. I do some of this after installation, but it's easier to do a first go-over now. Also, on this mantel I primed the moldings before cutting and fitting them to the mantel.

1. Fill any holes, dents, split seams, tearout, or cracks in your material with a water-based wood filler. On lumbercore plywood, I usually apply filler on the exposed edges, paying par-



The flexible blade on a good-quality putty knife will fill any voids in the material and not further mar the surface.



The finger joints, visible on the edges of the lumbercore, should be filled and sanded before you attach the parts to the mantel.



Use a large half-sheet sander or a sanding block to level any primed surfaces. Break square edges slightly but don't round them over too much.



All moldings should be filled, primed, and sanded for the best appearance.

Tip: If a water-based filler dries up, you can easily rehydrate it with a little tap water. You can even change the consistency if you prefer a thinner filler.

particular attention to the finger joints where the solid material was spliced.

2. When the filler is dry, I use a medium-grit (120 to 150) sandpaper to remove any excess and then level the surface.

3. Clean off the filled and sanded boards with a tack rag, then apply a water-based paint primer. For a fluid coating that lays down nicely, I thinned the primer about 20 percent.

It can be applied with either a brush or a roller. The primer fills and levels the wood and raises the grain slightly.

4. When the primer dries, look for any flaws that might have been missed the first time around, and fill them. Apply a second thinned coat of primer, and when dry sand again with 150-grit to 180-grit paper. Now the surface is ready for paint.

Installing the Mantel

Anchoring the foundation

Unless your walls are flat and plumb and you can determine the location of the studs behind, attach furring strips to the wall first, then attach the foundation to the strips. That way the principal method of attachment, no matter what you choose, will eventually be hidden by the mantel parts. In this case the brick masonry surrounding the opening was $\frac{1}{2}$ in. higher than the surrounding plaster wall. In order to make up this difference and give myself a tiny margin, I cut my furring strips to $\frac{5}{8}$ -in. thickness.

1. Attach furring strips to the wall. The furring strips can be secured with lead anchors, masonry screws, or cut nails.
2. Position the foundation against the wall, and center it on the opening.
3. Check the foundation for plumb and level, then screw it to the furring strips with #8 wood screws. Locate the fasteners so they'll be covered over by the other mantel parts later.

Building up the mantel

With the foundation securely in place, you can apply the next layer of mantel parts. Working from the bottom up may seem more logical, but I worked from the top down and scribed the plinth blocks to the floor last.

1. Attach the architrave to the foundation with 1½-in. screws. Make sure the top edge is even



Furring strips, shimmed plumb as needed and attached to the wall surface, provide good solid support for the foundation. Use the appropriate fastener based on the wall material.



Position the braced foundation against the furring strips. Make sure it's plumb and leveled, then screw it to the strips with #8 by 1½-in. wood screws.



This detail shows the capital molding that caps the pilasters.

ARCHITRAVE-PILASTER JOINT

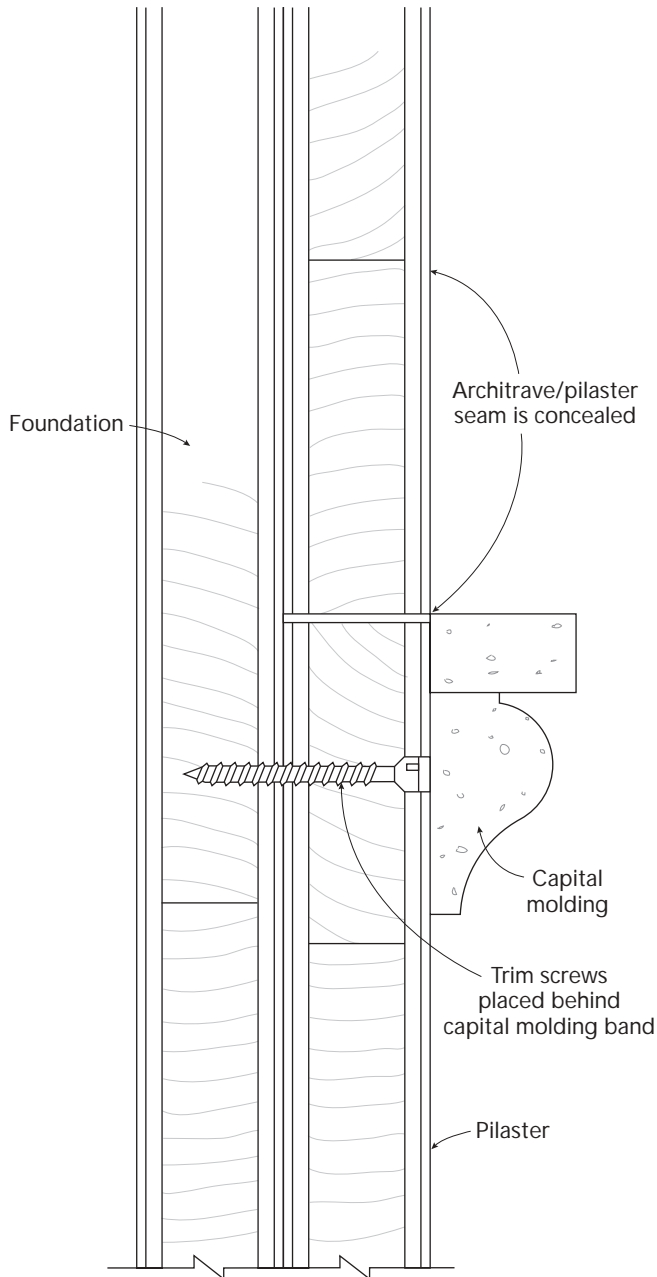

The capital band (molding set at the top of the pilasters) is placed over the trim screws attaching the pilaster to the foundation.



With the architrave in place, set the pilasters, using biscuits for alignment and added strength.

with the foundation board and that the spaces at the ends are equal.

2. Position the pilasters under the architrave, and add the biscuits and glue to reinforce the joint. Secure the pilasters to the foundation with 1/4-in. screws. Locate the screws at the bottom and top of the pilasters, where they'll be covered over with the capital and torus moldings.

3. Fit the plinth blocks. Once the pilasters are in place, measure the remaining space for the plinth blocks. On both sides of this mantel there was a small discrepancy between the wood floor and the slightly raised brick of the hearth. So I scribed the ends of the plinths to fit, made the cut with a jigsaw, and attached them to the foundation with countersunk trim screws.

PLINTH

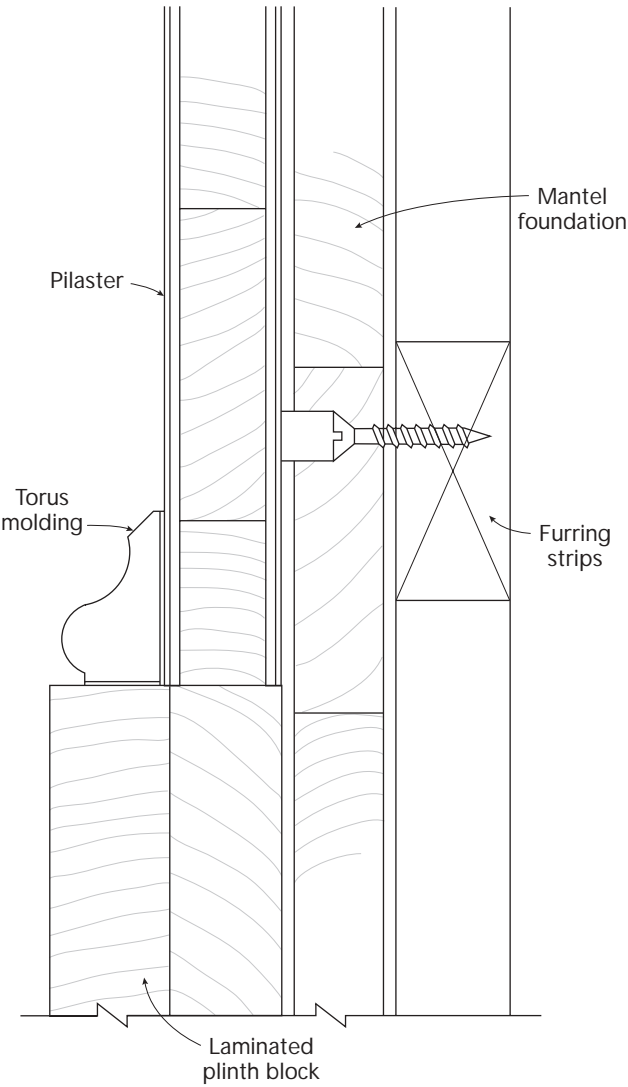

The torus band (molding set at the bottom of the pilasters) creates a pleasing transition from the plinth block to the pilaster and helps to visually anchor the mantel.

After the plinth blocks are scribed to the hearth, screw them to the foundation with trim screws.



Blocking for the cove molding

In order to provide a stable bed for the cornice molding, I made up some blocks to be placed along the top edge of the frieze and under the mantel shelf. The 45-degree face of these blocks supported the cornice molding at a consistent angle and ensured that the miters would line up properly. To support the small return sections of the cornice, I added a small piece of wood to the back of the angled blocking.

1. Saw the cove blocking from a piece of 2-by stock. Make sure the angle of the blocking

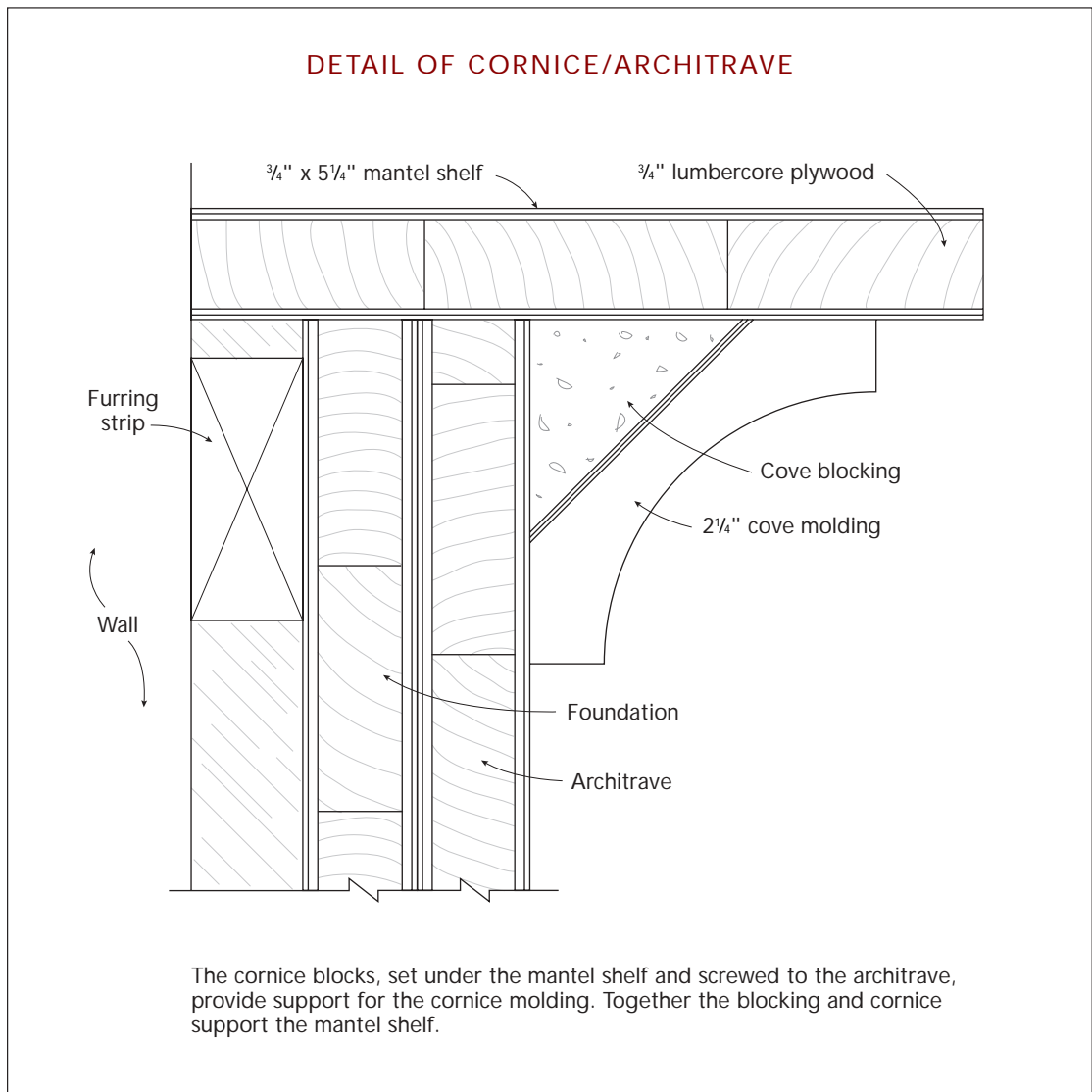



A small block is glued to the angled cove blocking. This supports the cornice molding return piece.



Screw angled cornice blocks along the top edge of the architrave.

Preassembled Molding Bands

On any project, moldings attract my attention. I always look to see whether the profile matches up and wraps around the corner cleanly. And of course, I like to see tight miters. If you're laying down the molding as you go, this is sometimes difficult to achieve. To make the job easier, I often build my bands first and then attach them to the mantel.

By mitering, gluing, and nailing the bands together first, you can coax tight joints at the corners, allow them to dry, and then fill and sand them. All of this critical work is a lot easier if you can freely adjust the molding band. In addition, once the band is dry, it will flex slightly and conform to its position on the mantel—while the miter remains tight. And the constructed band will stay in place with fewer nails than if it were laid up one piece at a time.

I cut the sections on a miter saw to within $\frac{1}{32}$ in., then I plane them to fit with a low-angle block plane. When I'm satisfied with the fit, I glue the miters and nail them together with a pin nailer. I use a fixed block as a guide to assemble the pieces.



A preassembled band of molding can be gently coaxed into place—while the miter remains tight.



This detail shows the plinth with the torus molding.



After setting the legs of the compass to the widest gap between the mantel shelf and the wall, drag the compass along the length of the shelf. Here the mantel shelf is still oversize, so the scribed amount is a full inch larger than the widest gap.

face matches the angle of the cove molding you're using.
 2. Attach the cove blocking through predrilled holes with trim-head screws.

The Moldings and Mantel Shelf

The conventional approach to installing moldings is to work your way around the mantel from one side to the other, fitting one piece to the next. (For an alternate approach, see "Pre-assembled Molding Bands" on p. 61.)

The mantel shelf

In the 18th and 19th centuries, woodwork was attached to the studs, then the walls were plastered, with the woodwork acting as a gauge or stop. The finish coat of plaster was then brought up to the woodwork. This method produced an interesting junction where the woodwork and plaster met that was soft and easy on the eye. But today's woodworkers and finish carpenters scribe their work to conform to the walls.

1. Set a compass to the width of the widest gap between the straight edge of the shelf and the wall.
2. With the pin leg of the compass resting against the wall and the pencil leg on the mantel shelf, pull the compass along the wall and shelf. This will result in a pencil line on the shelf that will mimic the wall surface.
3. Cut along the pencil line, then use a plane or rasp for final fitting.

The cove molding

I cut the cove molding on a miter saw outfitted with a special support carriage to hold the molding at the correct angle.

1. Cut the cove molding to fit.
2. Nail the cove to the cove blocks and mantel shelf with finish nails. Add some glue to the miters to help hold the joints closed.
3. When cutting the short return miter, make the 45-degree cut on a longer piece, then make the square cut to release the return from the longer stock.

The capital and torus moldings

1. Cut and fit these moldings around the pilasters.
2. Use a finish nailer for the long pieces and a pin nailer (or just glue) for the short returns.
3. Cut the side cap molding, and nail it to the edge of the foundation board. If necessary, scribe it to fit cleanly against the wall.

Painting the Mantel

Final preparations

With the mantel primed, sanded, and installed, there might be small gaps where the various sections of the mantel meet. Although they don't appear unsightly now, these gaps will stand out later and will work against a clean and unified appearance when the mantel is painted.

1. Fill any exposed screw or nail holes with putty.
2. Use a high-quality water-based caulk (Phenoseal® brand takes paint beautifully) in an applicator gun to apply a small continuous bead anywhere there is a gap. Within minutes of applying the caulk, wipe away any excess with a damp rag.

Applying finish coats

I used a water-based latex paint for the final coating of the mantel. For a project like this, I don't think oil-based paint offers any great advantages. I wanted a smooth surface with just a hint of brush marks that would imitate the finish on period woodwork.

The secret to a good job is to take your time, so I decided to apply the paint in several light coats. A thin coat levels nicely and dries more quickly and completely than a single heavy coat. I thinned out the paint about 20 percent and used a good-quality 2-in. synthetic brush. I started on the edges, then did the inside corners, and finished up with the large flat areas. Wait until each coat is thoroughly dry before proceeding with the next coat. The whole mantel required three coats of paint and a couple of 15-minute touchup sessions.



Nail on the capital molding with a pin nailer. Don't try to nail the miter or the wood may split.



The finish coat of paint should be applied in several thin layers. A thin coat of paint will level out nicely and dry quickly.