

Radiator Fan

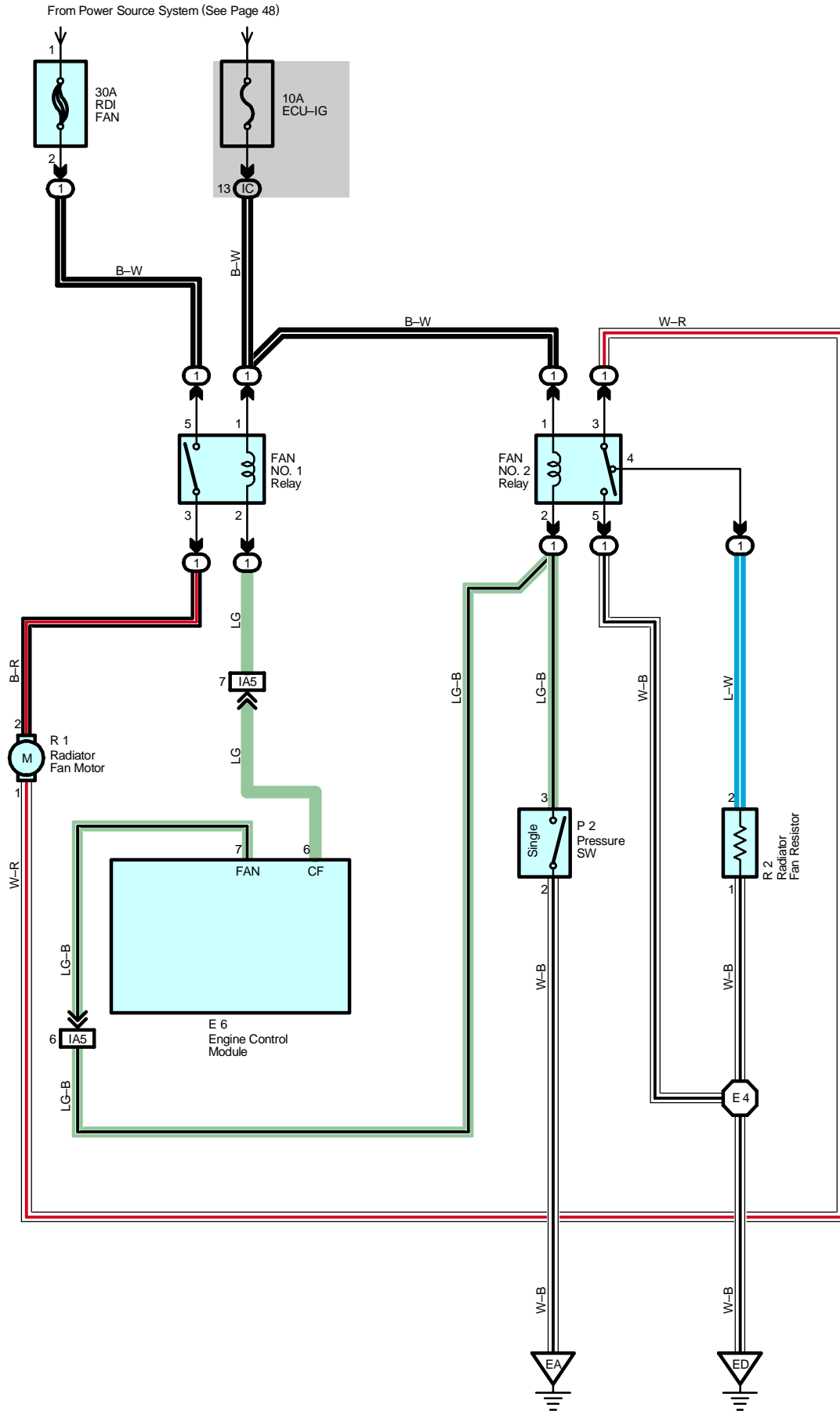

System Outline

The current is applied at all times through the RDI FAN fuse to TERMINAL 5 of the FAN NO.1 relay.

When the ignition SW is turned on, the current flows through the ECU-IG fuse to FAN NO.1 relay (Coil side) to TERMINAL 6 of the engine control module. At the same time as this current flow, the current from ECU-IG fuse flows to the FAN NO.2 relay (Coil side) to TERMINAL 3 of the pressure SW.

1. Low Speed Operation

When the A/C system is operating, the FAN NO.1 Relay is turned on. As a result, the current flows from the RDI FAN fuse to FAN NO.1 relay (Point side) to TERMINAL 2 of the radiator fan motor to TERMINAL 1 to TERMINAL 3 of the FAN NO.2 relay to TERMINAL 4 to TERMINAL 2 of the radiator fan resistor to TERMINAL 1 to GROUND, and the radiator fan motor rotates at low speed.

2. High Speed Operation

When the pressure SW is on or engine control module operated, the FAN NO.1 and NO.2 relay is turned on. As a result, the current flows from the RDI FAN fuse to FAN NO.1 relay (Point side) to radiator fan motor to TERMINAL 3 of the FAN NO.2 Relay to TERMINAL 5 to GROUND, and the radiator fan motor rotates at high speed.

Service Hints

P2 Pressure SW

3-2 : Open below approx. 12.5 kgf/cm² (178 psi, 1225 kpa)

Close above approx. 15.5 kgf/cm² (220 psi, 1520 kpa)

○ : Parts Location

Code	See Page	Code	See Page	Code	See Page
E6	34	R1	33		
P2	33	R2	33		

○ : Relay Blocks

Code	See Page	Relay Blocks (Relay Block Location)
1	22	Engine Room R/B (Engine Compartment Left)

○ : Junction Block and Wire Harness Connector

Code	See Page	Junction Block and Wire Harness (Connector Location)
IC	25	Engine Room Main Wire and Instrument Panel J/B (Lower Finish Panel)

□ : Connector Joining Wire Harness and Wire Harness

Code	See Page	Joining Wire Harness and Wire Harness (Connector Location)
IA5	40	Engine Room Main Wire and Instrument Panel Wire (Left Side of the Instrument Panel Reinforcement)

▽ : Ground Points

Code	See Page	Ground Points Location
EA	38	Front Right Fender
ED	38	Front Left Suspension Tower

○ : Splice Points

Code	See Page	Wire Harness with Splice Points	Code	See Page	Wire Harness with Splice Points
E4	38	Engine Room Main Wire			