

Light Reminder Buzzer and Key Reminder Buzzer

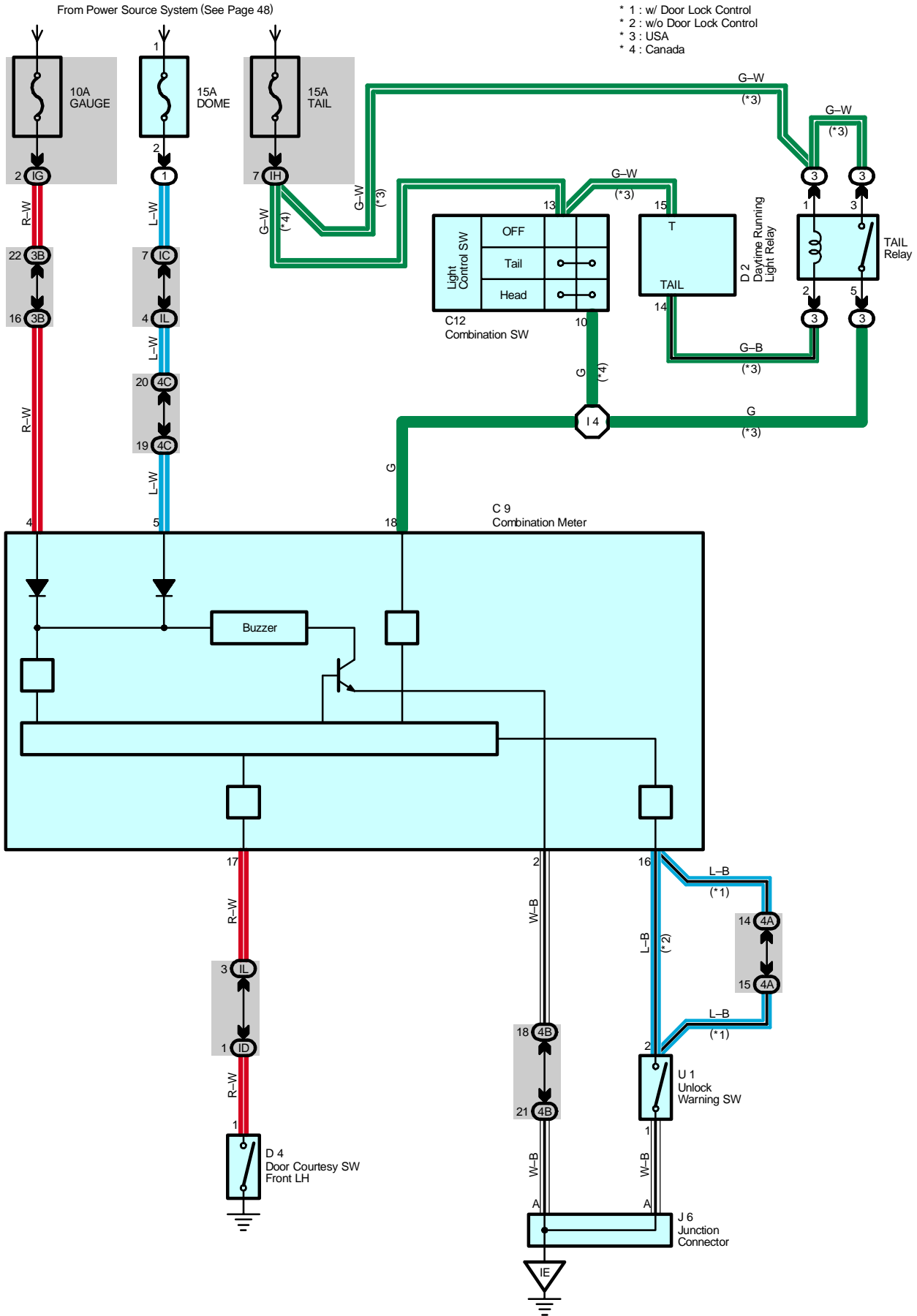

System Outline

The current is applied at all times to TERMINAL 5 of the combination meter through the DOME fuse. When the ignition SW is turned to ON position, the current flows to TERMINAL 4 of the combination meter through the GAUGE fuse. When the light control SW is turned to Tail or Head position, current is applied to TERMINAL 18 of the combination meter through the TAIL fuse via the TAIL relay (USA) or the light control SW (Canada).

1. Light Reminder System

When the light control SW is in Tail or Head position, the ignition SW turned to OFF from ON position, and the driver's door opened (Door courtesy SW on), the current flows to TERMINAL 4 of the combination meter stops. As a result, the combination meter is activated and current flows from TERMINAL 5 of the combination meter to TERMINAL 2 to GROUND, the buzzer in the combination meter goes on to remind the light is lighting up.

2. Key Reminder System

When the driver door is opened with the ignition SW off and ignition key remaining in the key cylinder (Unlock warning SW on), a signal is input from the unlock warning SW to TERMINAL 16 of the combination meter, and from the door courtesy SW front LH to TERMINAL 17 of the combination meter. As a result, the buzzer in the combination meter goes on and warns the driver that the key is remaining in the key cylinder.

Service Hints

C9 Combination Meter

- 4-Ground : Approx. 12 volts with the ignition SW at ON position
- 18-Ground : Approx. 12 volts with the light control SW at Tail or Head position
- 17-Ground : Continuity with the driver's door open
- 2-Ground : Always continuity

D4 Door Courtesy SW Front LH

- 1-Ground : Closed with the driver's door open

U1 Unlock Warning SW

- 2-1 : Closed with the ignition key in cylinder

○ : Parts Location

| Code | See Page | Code | See Page | Code | See Page |
|------|----------|------|----------|------|----------|
| C9 | 34 | D2 | 34 | J6 | 35 |
| C12 | 34 | D4 | 36 | U1 | 35 |

○ : Relay Blocks

| Code | See Page | Relay Blocks (Relay Block Location) |
|------|----------|---|
| 1 | 22 | Engine Room R/B (Engine Compartment Left) |
| 3 | 28 | RH R/B (Right Side of the Instrument Panel Reinforcement) |

○ : Junction Block and Wire Harness Connector

| Code | See Page | Junction Block and Wire Harness (Connector Location) |
|------|----------|---|
| IC | 25 | Engine Room Main Wire and Instrument Panel J/B (Lower Finish Panel) |
| ID | 25 | Floor Wire and Instrument Panel J/B (Lower Finish Panel) |
| IG | 25 | Instrument Panel Wire and Instrument Panel J/B (Lower Finish Panel) |
| IH | | |
| IL | | |
| 3B | 28 | Instrument Panel Wire and RH J/B (Right Side of the Instrument Panel Reinforcement) |
| 4A | 30 | Instrument Panel Wire and Center J/B (Behind the Combination Meter) |
| 4B | | |
| 4C | | |

▽ : Ground Points

| Code | See Page | Ground Points Location |
|------|----------|------------------------------|
| IE | 40 | Behind the Combination Meter |

Light Reminder Buzzer and Key Reminder Buzzer



: Splice Points

| Code | See Page | Wire Harness with Splice Points | Code | See Page | Wire Harness with Splice Points |
|------|--------------------|---------------------------------|------|----------|---------------------------------|
| I4 | 42 | Instrument Panel Wire | | | |

