

# INSPECTION

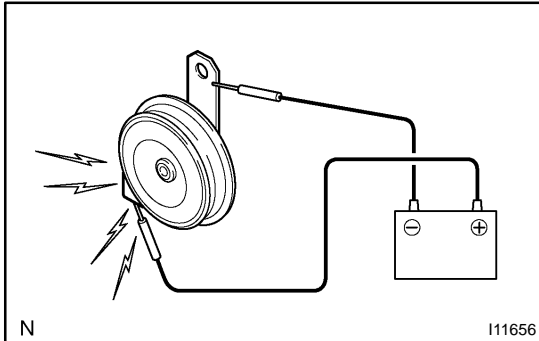

## 1. INSPECT LOW PITCHED HORN ASSY

- (a) Connect the positive (+) lead from the battery to the terminal and the negative (-) lead to the horn body, and check that the horn blows.

If the result is not as specified, replace the horn.

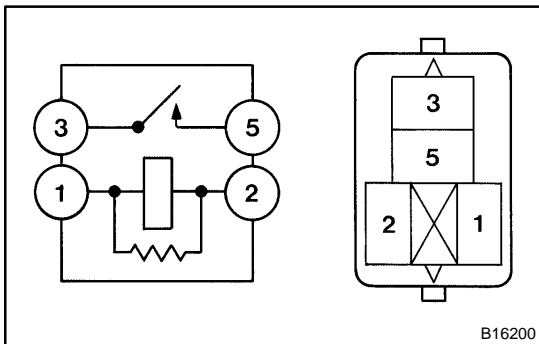

## 2. INSPECT HORN RELAY ASSY (Marking: HORN)

- (a) Remove the horn relay from the engine room J/B.
- (b) Inspect the horn relay continuity.

### Standard:

Terminal No.	Condition	Specified condition
1 ↔ 2	Constant	Continuity
3 ↔ 5	Apply B+ between terminals 1 and 2	

If the result is not as specified, replace the relay.