

DISPOSAL

HINT:

When scrapping vehicles equipped with a seat belt pretensioner or disposing of a front seat outer belt (with seat belt pretensioner) always first activate the seat belt pretensioner in accordance with the procedure described below. If any abnormality occurs in the seat belt pretensioner operation, contact the SERVICE DEPT. of the TOYOTA MOTOR SALES, U.S.A., INC. When disposing of a front seat outer belt (with seat belt pretensioner) activated in a collision, follow the same procedure given in step 1-(e) in "DISPOSAL".

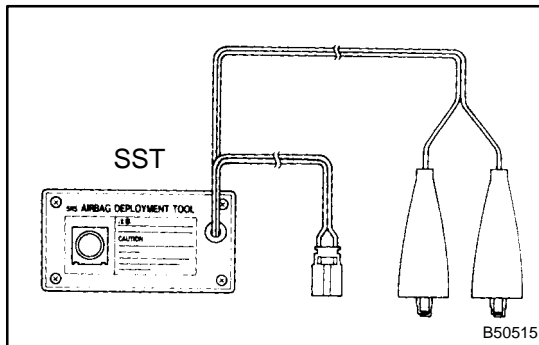

CAUTION:

- Never dispose of front seat outer belt which has an in-activated pretensioner.
- The seat belt pretensioner produces a sizeable exploding sound when it activates, so perform the operation out-of-door and where it will not create a nuisance to nearby residents.
- When activating a front seat outer belt (with seat belt pretensioner), perform the operation at least 10 m (33 ft) away from the front seat outer belt.
- Use gloves and safety glasses when handling a front seat belt with activated pretensioner.
- Always wash your hands with water after completing the operation.
- Do not apply water, etc. to a front seat outer belt with activated pretensioner.
- When activating the seat belt pretensioner, always use the specified SST. (SRS Airbag Deployment Tool) Perform the operation in a place away from electrical noise.

SST 09082-00700

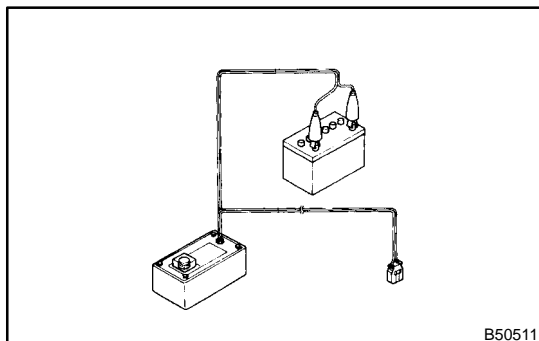

1. DISPOSE OF FRONT SEAT OUTER BELT ASSY RH (WHEN INSTALLED WITH VEHICLE)

HINT:

Check that the battery positive voltage is above 12 V.

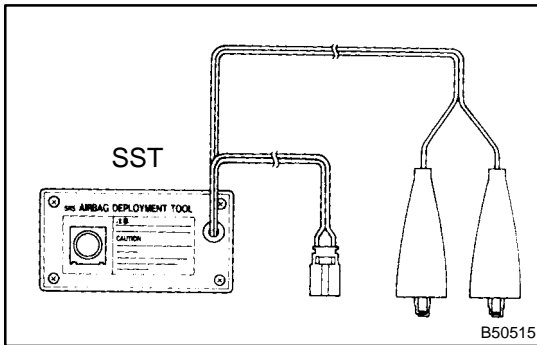

(a) Check the functioning of SST.

CAUTION:

When activating the seat belt pretensioner, always use a specified SST.

SST 09082-00700, 09082-00770

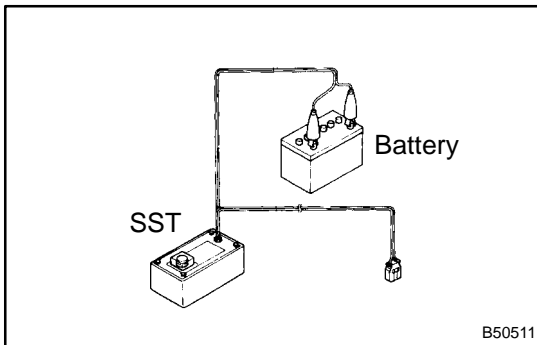

(1) Connect the SST to the battery.

Connect the red clip of the SST to the battery positive (+) terminal and the black clip to the battery negative (-) terminal.

HINT:

Do not connect the yellow connector which will be connected to the seat belt pretensioner.

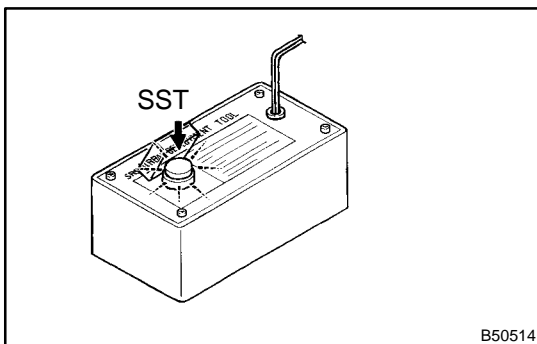

(2) Check the functioning of SST.

Press the SST activation switch, and check that the LED of the SST activation switch lights up.

CAUTION:

If the LED lights up when the activation switch is not pressed, the SST probably malfunctions, so definitely do not use the SST.

(b) Disconnect the SST from the battery.

(c) Disconnect the pretensioner connector.

- (1) Disconnect the battery negative terminal.
- (2) Check the SRS airbag system (See page 60-1).
- (3) Remove the front door scuff plate RH (See page 76-21).
- (4) Remove the rear door scuff plate RH (See page 76-21).
- (5) Remove the front door opening trim RH.
- (6) Remove the rear door opening trim RH.
- (7) Remove center pillar garnish lower RH (See page 76-21).

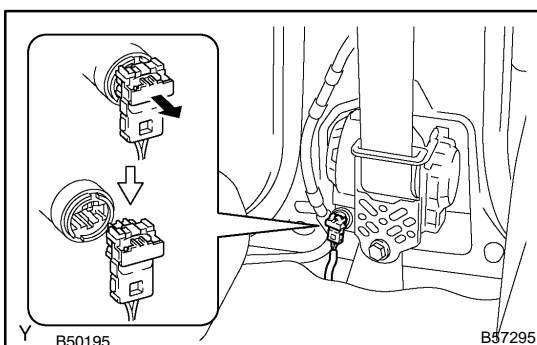

(8) Disconnect the pretensioner connector as shown in the illustration.

(d) Install the SST.

- (1) Install the floor anchor of the seat belt.

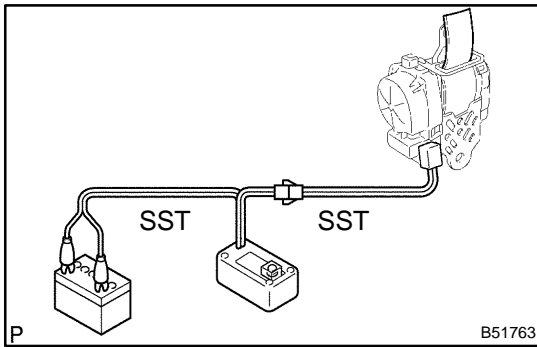

- (2) Connect the 2 SSTs, then connect them to the seat belt pretensioner.

SST 09082-00700, 09082-00770

NOTICE:

To avoid damaging the SST connector and wire harness, do not lock the secondary lock of the twin lock.

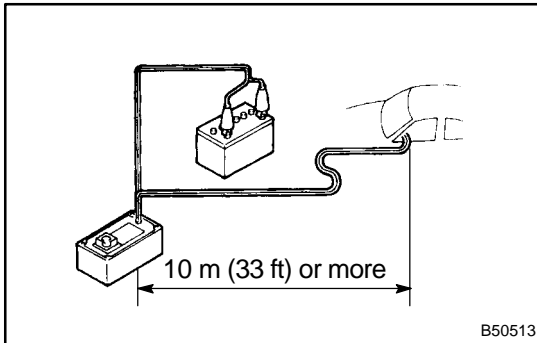

- (3) Move the SST at least 10 m (33 ft) away from the front of the vehicle.

- (4) Close all the doors and windows of the vehicle.

NOTICE:

Take care not to damage the SST wire harness.

- (5) Connect the SST red clip to the battery positive (+) terminal and the black clip to the negative (-) terminal.

- (e) Activate the seat belt pretensioner.

- (1) Confirm that no one is inside the vehicle or within 10 m (33 ft) area around the vehicle.
 (2) Press the SST activation switch and activate the seat belt pretensioner.

HINT:

The seat belt pretensioner operates simultaneously with the LED of the SST activation switch lighting up.

- (f) Dispose of the front seat outer belt (with seat belt pretensioner).

CAUTION:

- The rear outer belt is very hot when the seat belt pretensioner is activated, so leave it alone for at least 30 minutes after activation.
- Use gloves and safety glasses when handling a front seat outer belt with activated seat belt pretensioner.
- Always wash your hands with water after completing the operation.
- Do not apply water, etc. to a front seat outer belt with activated seat belt pretensioner.

HINT:

When scrapping a vehicle, activate the seat belt pretensioner and scrap the vehicle with activated front seat outer belt being installed.

2. DISPOSE OF FRONT SEAT OUTER BELT ASSY RH (WHEN NOT INSTALLED WITH VEHICLE)

NOTICE:

- When disposing of a front seat outer belt (with seat belt pretensioner) only, never use the customer's vehicle to activate the seat belt pretensioner.
- Be sure to follow the procedure given on the next page when activating the seat belt pretensioner.

- (a) Remove the front seat outer belt assembly (See page 61-7).

HINT:

Cut the belt near the seat belt retractor.

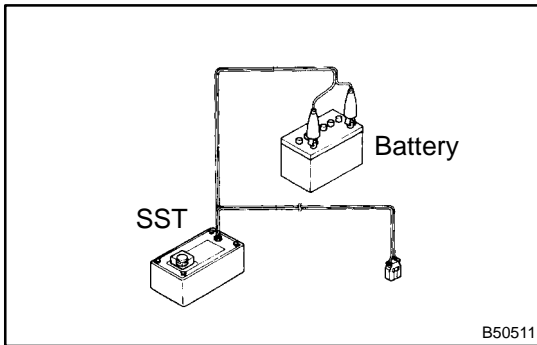

- (b) Check the functioning of SST (See step 1-(a)).
SST 09082-00700, 09082-00770

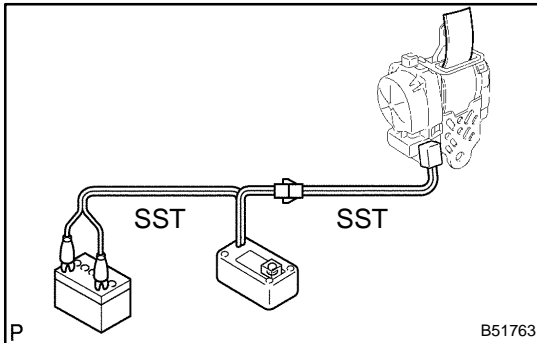

- (c) Install the SST.
(1) Connect the 2 SSTs, then connect them to the seat belt pretensioner.
SST 09082-00700, 09082-00770

NOTICE:

To avoid damaging the SST connector and wire harness, do not lock the secondary lock of the twin lock.

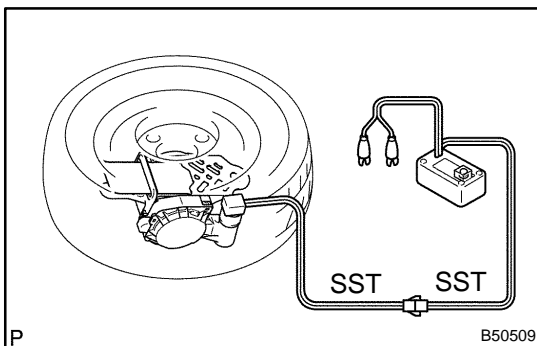

- (2) Place the front seat outer belt on the ground and cover it with the disc wheel with tire.

NOTICE:

Place the front seat outer belt, as shown in the illustration.

- (3) Move the SST at least 10 m (33 ft) away from the disc wheel.

NOTICE:

Take care not to damage the SST wire harness.

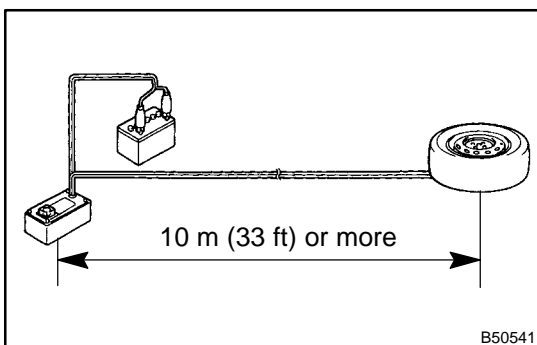

- (d) Activate the seat belt pretensioner.
(1) Connect the SST red clip to the battery positive (+) terminal and black clip to the battery negative (-) terminal.
(2) Check that no one is within 10 m (33 ft) area around the disc wheel.
(3) Press the SST activation switch and activate the seat belt pretensioner.

HINT:

The seat belt pretensioner operates simultaneously with the LED of the SST activation switch lighting up.

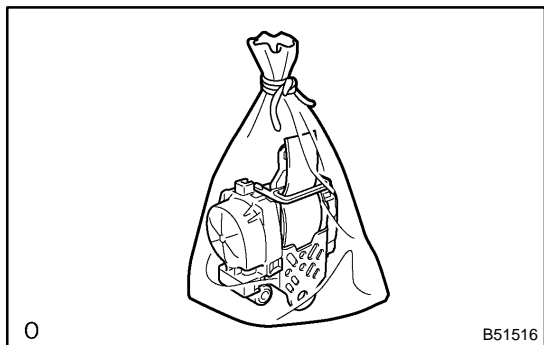

- (e) Dispose of the front seat outer belt (with seat belt pretensioner).

CAUTION:

- **The rear outer belt is very hot when the seat belt pretensioner is activated, so leave it alone for at least 30 minutes after activation.**
- **Use gloves and safety glasses when handling a front seat outer belt with activated seat belt pretensioner.**
- **Always wash your hands with water after completing the operation.**
- **Do not apply water, etc. to a front seat outer belt with activated seat belt pretensioner.**
 - (1) Remove the disc wheel and SST.
 - (2) Place the front seat outer belt in a vinyl bag, tie the end tightly and dispose of it in the same way as other general parts.