

OVERHAUL

1. REMOVE MANUAL TRANSAXLE ASSY (See page 41-17)

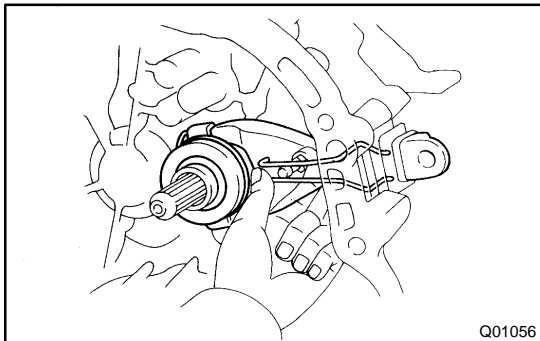

2. REMOVE CLUTCH RELEASE FORK SUB-ASSY

- (a) Remove the clutch release fork with clutch release bearing from the transaxle assy.

3. REMOVE CLUTCH RELEASE BEARING ASSY

- (a) Remove the clutch release bearing assy from the clutch release fork.

4. REMOVE RELEASE FORK SUPPORT

- (a) Remove the release fork support from the transaxle assy.

5. REMOVE RELEASE BEARING HUB CLIP

6. REMOVE CLUTCH RELEASE FORK BOOT

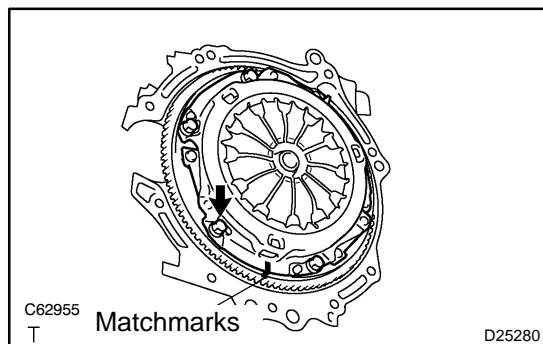

7. REMOVE CLUTCH COVER ASSY

- (a) Align the matchmarks on the clutch cover assy with the one on the flywheel sub-assy.
 (b) Loosen each set bolt one turn at a time until spring tension is released.
 (c) Remove the 6 bolts, and pull off the clutch cover assy.

NOTICE:

Do not drop the clutch disc assy.

8. REMOVE CLUTCH DISC ASSY

NOTICE:

Keep the lining part of the clutch disc assy, the pressure plate and surface of the flywheel sub-assy away from oil and foreign attachment.

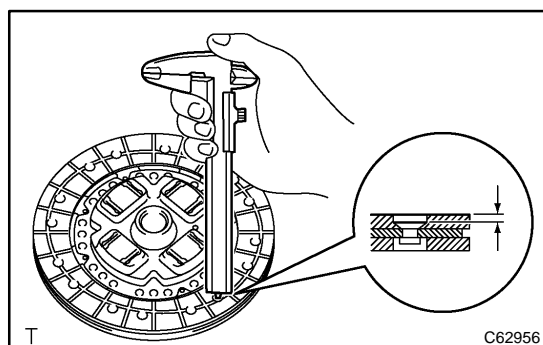

9. INSPECT CLUTCH DISC ASSY

- (a) Using vernier calipers, measure the rivet head depth.
Maximum rivet depth: 0.3 mm (0.012 in.)

If necessary, replace the clutch disc assy.

- (b) Install the clutch disc assy to the transaxle assy.

NOTICE:

Take care not to insert the clutch disc assy in the wrong direction.

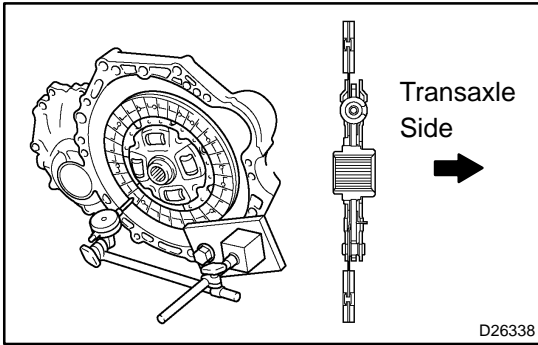

- (c) Using a dial indicator, check the clutch disc assy runout.
Minimum runout: 0.8 mm (0.031 in.)
 If necessary, replace the clutch disc assy.

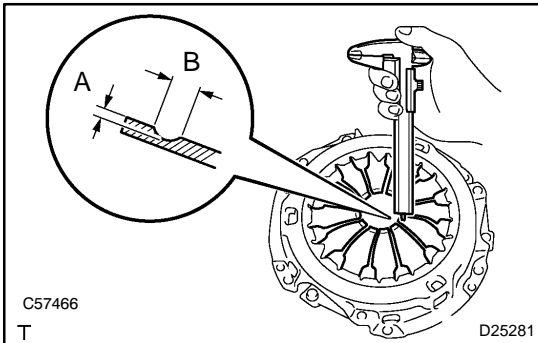

10. INSPECT CLUTCH COVER ASSY

- (a) Using vernier calipers, inspect the diaphragm spring for depth and width of wear.
Maximum:
A (Depth): 0.5 mm (0.020 in.)
B (Width): 6.0 mm (0.236 in.)
 If necessary, replace clutch cover assy.

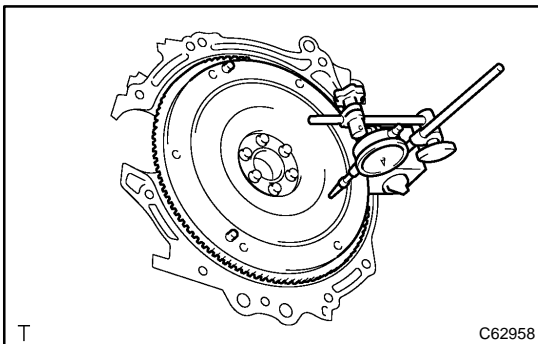

11. INSPECT FLYWHEEL SUB-ASSY

- (a) Using a dial indicator, inspect the flywheel sub-assy runout.
Maximum runout: 0.1 mm (0.004 in.)
 If necessary, replace the flywheel sub-assy.

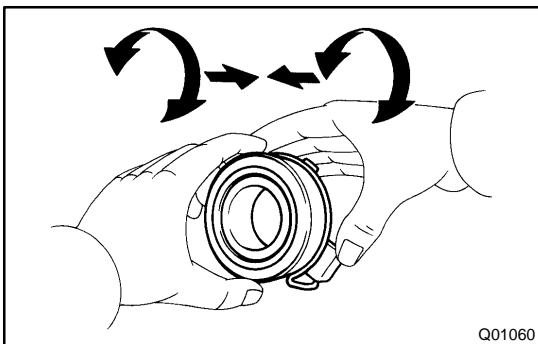

12. INSPECT CLUTCH RELEASE BEARING ASSY

- (a) Turn the release bearing by hand while applying force in the axial direction.
HINT:
 The bearing is permanently lubricated and requires no cleaning or lubrication.
 If necessary, replace the release bearing assy.

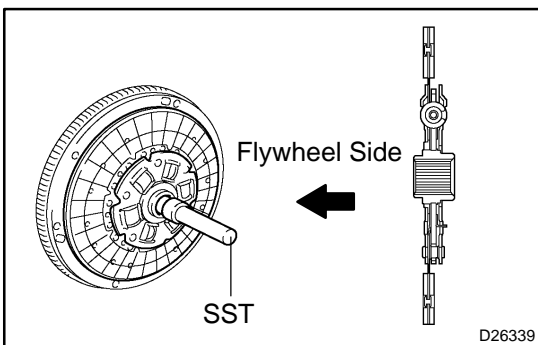

13. INSTALL CLUTCH DISC ASSY

- (a) Insert SST in the clutch disc assy, then insert them in the flywheel sub-assy.
 SST 09301-00210
NOTICE:
Take care not to insert clutch disc assy in the wrong direction.

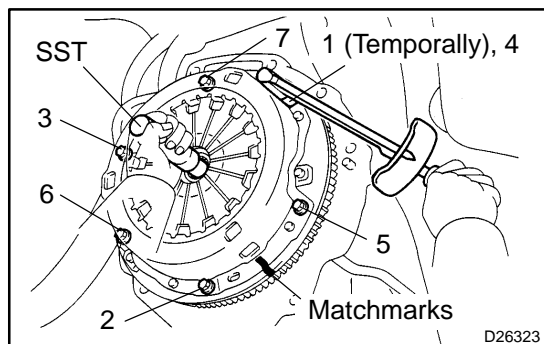
**14. INSTALL CLUTCH COVER ASSY**

- (a) Align the matchmarks on the clutch cover assy and fly-wheel sub-assy.
- (b) Following the procedures shown in the illustration, tighten the 6 bolts, in the order starting the bolt locating near the knock pin on the top.

Torque: 19.1 N·m (195 kgf·cm, 14 ft·lbf)

HINT:

- Following the order in the illustration, tighten the bolts at a time evenly.
- Move SST up and down, right and left lightly, after checking that the disc is in the center, tighten the bolts.

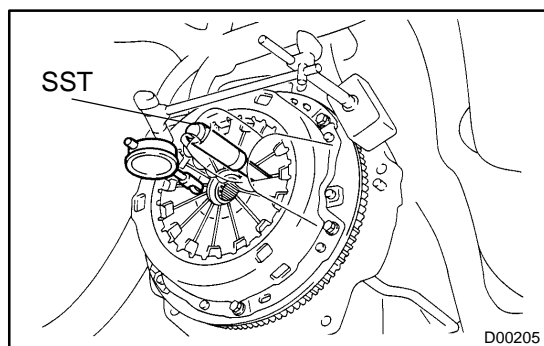
**15. INSPECT AND ADJUST CLUTCH COVER ASSY**

- (a) Using a dial indicator with roller instrument, check the diaphragm spring tip alignment.

Maximum non-alignment: 0.5 mm (0.020 in.)

If alignment is not as specified, using SST, adjust the diaphragm spring tip alignment.

SST 09333-00013

16. INSTALL RELEASE FORK SUPPORT

- (a) Install the release fork support to the transaxle assy.

Torque: 36.8 N·m (375 kgf·cm, 27 ft·lbf)

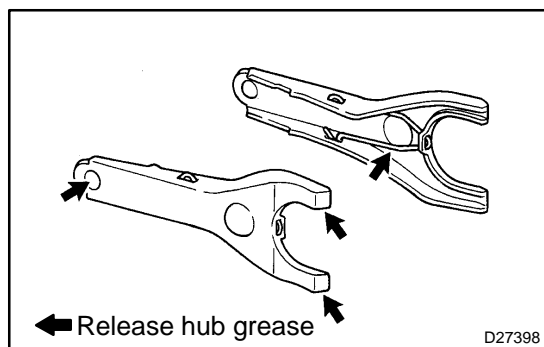
17. INSTALL RELEASE BEARING HUB CLIP**18. INSTALL CLUTCH RELEASE FORK SUB-ASSY**

- (a) Apply release hub grease to the release fork and release bearing assy contact, release fork and push rod contact and release fork pivot points.

Sealant:

Part No. 08887-01806, RELEASE HUB GREASE or equivalent

- (b) Install the release fork to the release bearing assy.

19. INSTALL CLUTCH RELEASE BEARING ASSY

- (a) Apply the clutch spline grease to the input shaft spline.

Sealant:

Part No. 08887-01706, CLUTCH SPLINE GREASE or equivalent

- (b) Install the bearing to the release fork, and then install them to the transaxle assy.

NOTICE:

After the installation, move the fork forward and backward to check that the release bearing slides smoothly.

20. INSTALL CLUTCH RELEASE FORK BOOT
21. INSTALL MANUAL TRANSAXLE ASSY (See page [41-17](#))