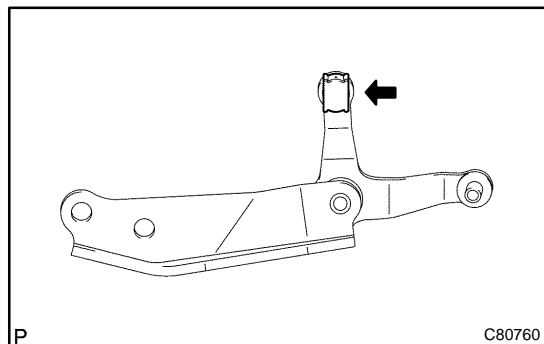
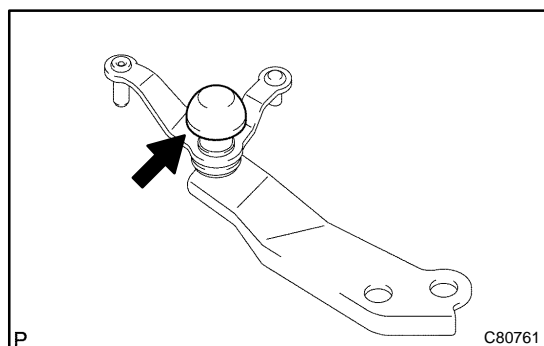

## OVERHAUL

**1. REMOVE CONTROL SHIFT LEVER BUSH**

- (a) Remove the control shift lever bush from the selecting bellcrank assy.

**2. REMOVE SELECTING BELLCRANK DUST COVER NO.1**

- (a) Remove the selecting bellcrank dust cover No.1 from the selecting bellcrank assy.

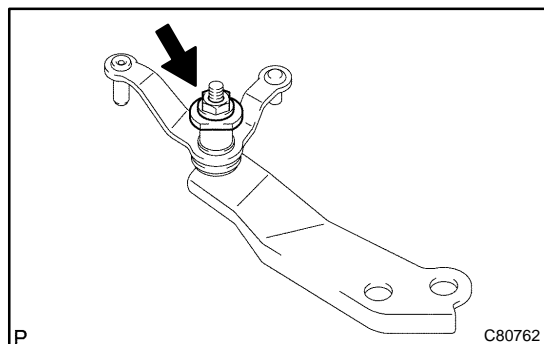
**3. REMOVE SELECTING BELL CRANK NO.2**

- (a) Remove the nut, spring washer and selecting bellcrank No.2 plate washer.  
 (b) Remove the selecting bellcrank No.2 from the selecting bellcrank support.

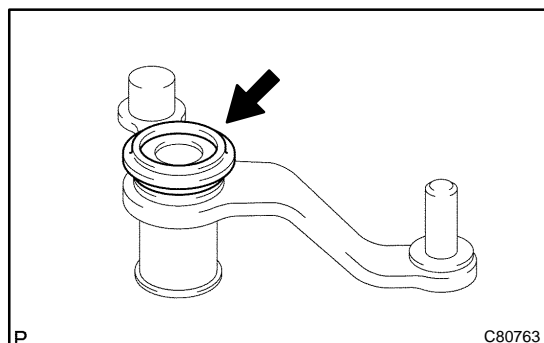
**4. REMOVE SELECTING BELLCRANK DUST COVER NO.2**

- (a) Remove the selecting bellcrank dust cover No.2 from the selecting bellcrank No.2.

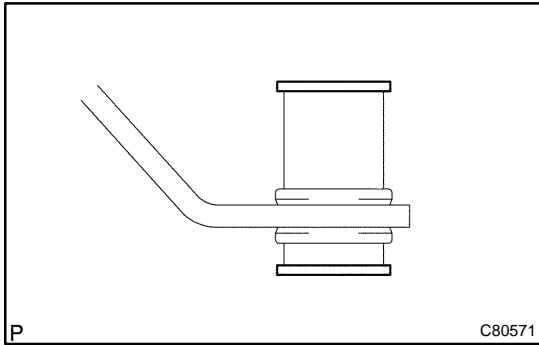
**5. REMOVE SELECTING BELLCRANK NO.2 BUSH**

- (a) Remove the 2 selecting bellcrank No.2 bushes from the selecting bellcrank No.2.

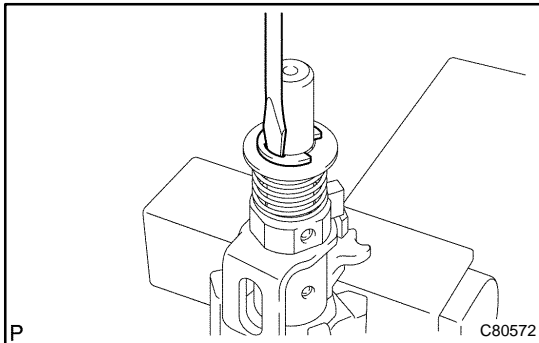
**6. REMOVE SELECT SPRING SEAT NO.2**

- (a) Using a screwdriver, remove the E-ring, select spring seat No.2 and select return spring No.2 from the shift & select lever shaft.

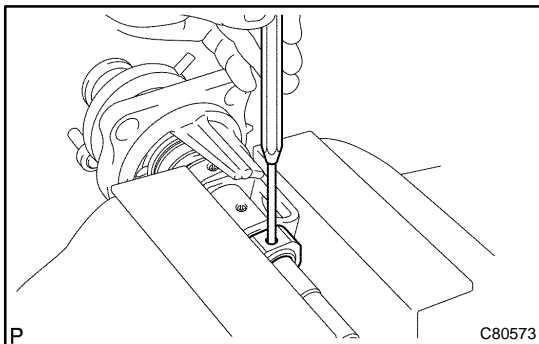
**7. REMOVE SHIFT LEVER INNER NO.2**

- (a) Using a pin punch ( $\phi$  5 mm) and a hammer, remove the slotted pin and shift lever inner No.2 from the shift & select lever shaft.

HINT:

Make sure the orientation of the shift lever inner No.2.

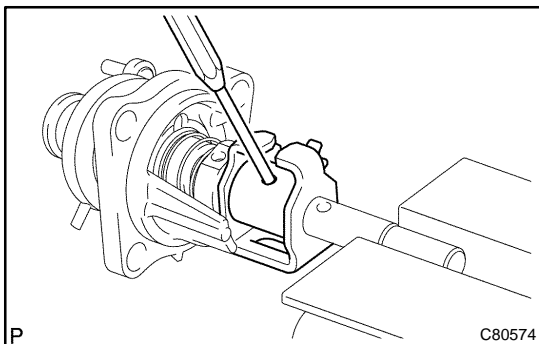
**8. REMOVE SHIFT LEVER INNER NO.1**

- (a) Using a pin punch ( $\phi$  5 mm) and a hammer, remove the slotted pin, shift lever inner No.1 and shift inter lock plate from the shift & select lever shaft.

HINT:

Make sure the orientation of the shift lever inner No.1.

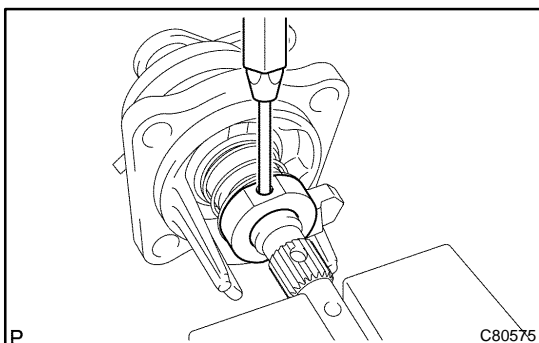
**9. REMOVE SELECT INNER LEVER**

- (a) Using a pin punch ( $\phi$  5 mm) and a hammer, remove the slotted pin, select inner lever, select return spring No.1 and select return spring seat No.1.

HINT:

Make sure the orientation of the select inner lever.

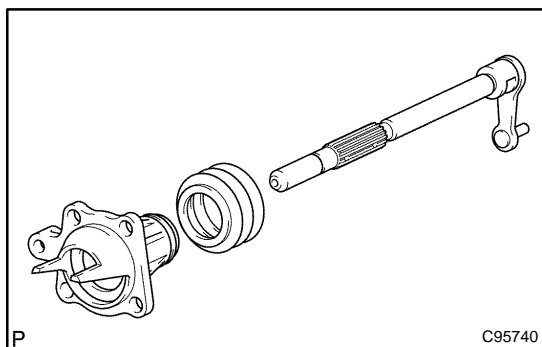
**10. REMOVE CONTROL SHAFT COVER**

- (a) Using 2 screwdrivers and a hammer, tap out the snap ring.
- (b) Remove the control shaft cover and shift & select lever shaft dust boot.

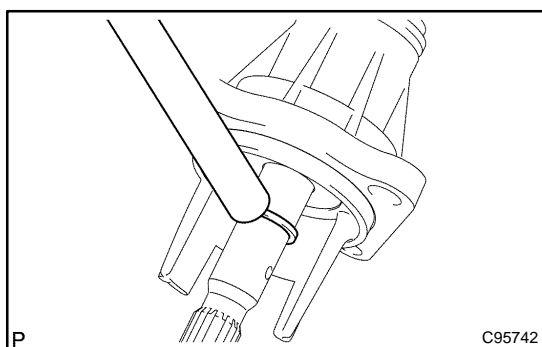
**11. REMOVE CONTROL SHAFT COVER OIL SEAL**

- (a) Using a screwdriver, remove the control shaft cover oil seal from the control shaft cover.

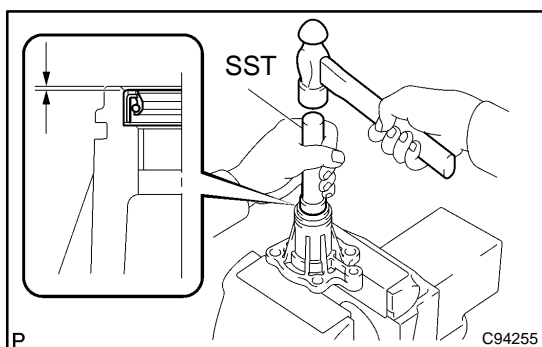
**12. INSTALL CONTROL SHAFT COVER OIL SEAL**

- (a) Using SST and a hammer, install a new control shaft cover oil seal to the control shaft cover.  
SST 09950-60010 (09951-00220), 09950-70010 (09951-07100)  
**Drive in depth: 0.7 ± 0.5 mm (0.0276 ± 0.0197 in.)**
- (b) Coat the lip of control shaft cover oil seal with MP grease.

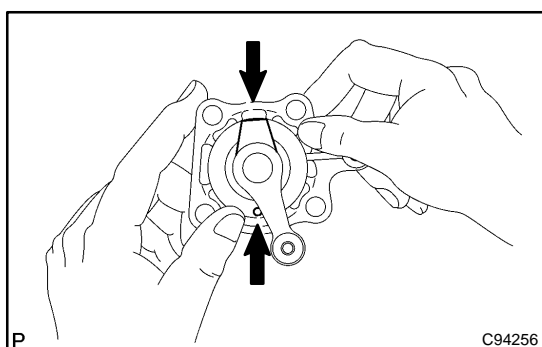
**13. INSTALL CONTROL SHAFT COVER**

- (a) Coat the shift & select lever shaft boot with MP grease, install it to the control shaft cover.
- (b) Install the control shaft cover to the shift & select lever.  
**HINT:**  
Install the dust boot with the projection up and the hole side down.
- (c) Coat the shift & select lever shaft with MP grease.

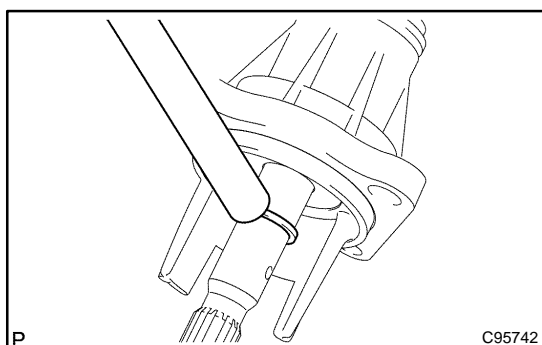

- (d) Using a brass bar and a hammer, tap in the snap ring to the shift & select lever shaft.

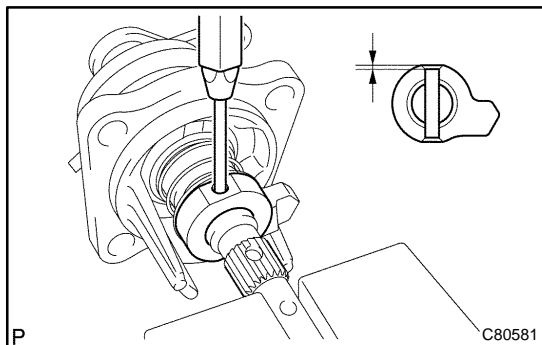
**14. INSTALL SELECT INNER LEVER**

- (a) Coat the select spring seat No.1 with MP grease, install it to the shift & select lever shaft.
- (b) Install the select return spring and select inner lever to the shift & select lever shaft.
- (c) Using a pin punch ( $\phi$  5 mm) and a hammer, install the slotted pin to the select lever inner lever.

**Drive in depth: 3.0 – 4.0 mm (0.1181 – 0.1575 in.)**

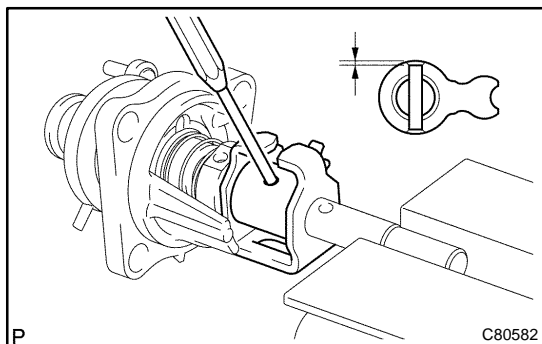
**15. INSTALL SHIFT LEVER INNER NO.1**

- (a) Coat the shift interlock plate and shift lever inner No.1 with MP grease.
- (b) Install the shift interlock plate with shift lever inner No.1 to the shift & select lever shaft.
- (c) Using a pin punch ( $\phi$  5 mm) and a hammer, install the slotted pin to the shift lever inner No.1.

**Drive in depth: 0 ± 0.5 mm (0 ± 0.0197 in.)**

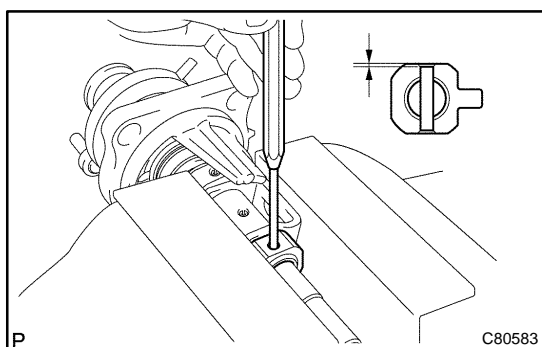
**16. INSTALL SHIFT LEVER INNER NO.2**

- (a) Install the shift lever inner No.2 to the shift & select lever shaft.
- (b) Using a pin punch ( $\phi$  5 mm) and a hammer, install the slotted pin to the shift lever inner No.2.

**Drive in depth: 0 ± 0.5 mm (0 ± 0.0197 in.)**

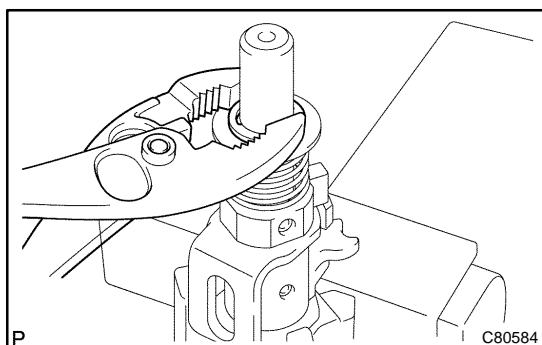
**17. INSTALL SELECT SPRING SEAT NO.2**

- (a) Coat the select spring seat No.2 with MP grease, install it with select return spring to the shift & select lever shaft.
- (b) Using a plier, install the E-ring to the shift & select lever shaft.

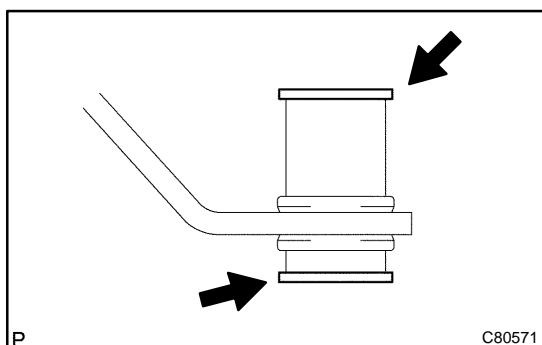
**18. INSTALL SELECTING BELLCRANK NO.2 BUSH**

- (a) Coat the selecting bellcrank No.2 bushes with MP grease, install them to the selecting bellcrank.

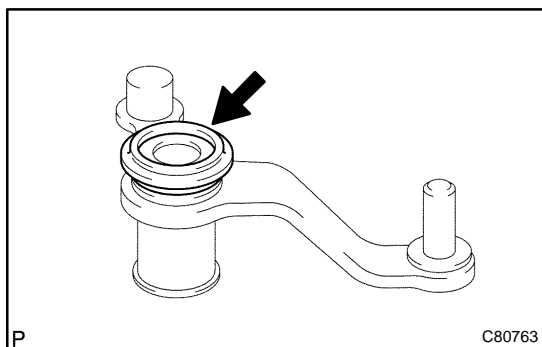

### 19. INSTALL SELECTING BELLCRANK DUST COVER NO.2

- (a) Coat the selecting bellcrank dust cover No.2 with MP grease, install it to the selecting bellcrank No.2.

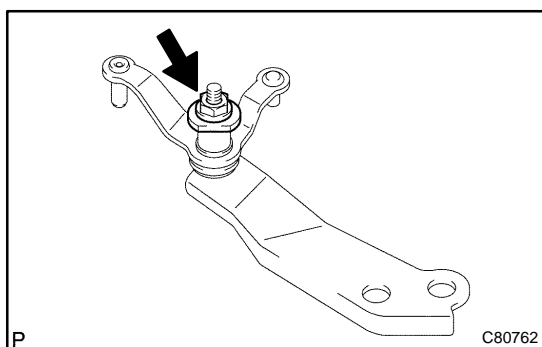

### 20. INSTALL SELECTING BELL CRANK NO.2

- (a) Install the selecting bellcrank No.2, selecting bellcrank No.2 plate washer and spring washer with nut.  
**Torque: 11.8 N·m (120 kgf·cm, 9 ft·lbf)**

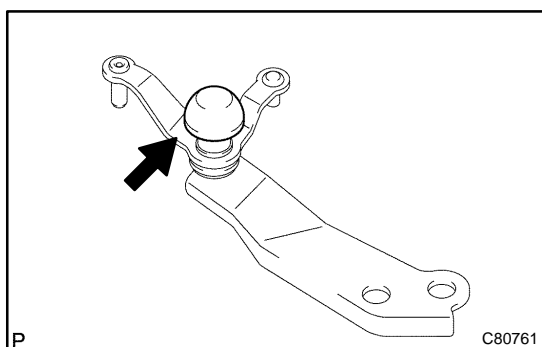

### 21. INSTALL SELECTING BELLCRANK DUST COVER NO.1

- (a) Install the selecting bellcrank dust cover No.1 to the selecting bellcrank assy.

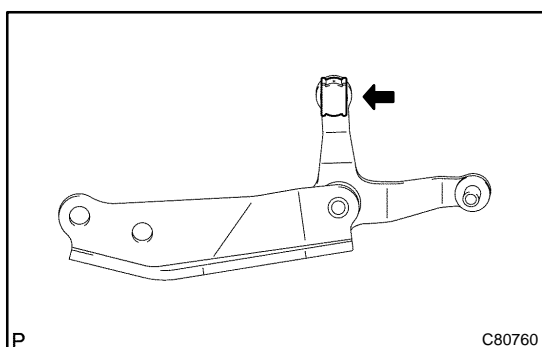

### 22. INSTALL CONTROL SHIFT LEVER BUSH

- (a) Coat the control shift lever bush with MP grease, install it to the selecting bellcrank assy.