

FLOOR SHIFT CABLE TRANSMISSION CONTROL SHIFT REPLACEMENT

41078-02

HINT:

COMPONENTS: See page 41-5

1. REMOVE AIR CONDITIONER UNIT ASSY (See page 55-17)

HINT:

Refer to the instructions for removal of the air conditioner unit assy.

2. SEPARATE AIR BAG SENSOR ASSY CENTER

(a) Remove the 3 bolts, separate the airbag sensor assy center.

3. REMOVE EXHAUST PIPE ASSY (See page 15-2)

4. REMOVE FRONT FLOOR HEAT INSULATOR NO.1

(a) Remove the 3 nuts and heat insulator No.1.

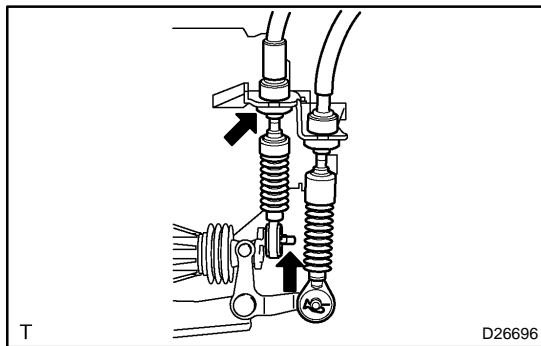

5. REMOVE FLOOR SHIFT CABLE TRANSMISSION CONTROL SHIFT

(a) Remove the clip and washer, separate the top of the shift cable from the transaxle.

(b) Remove the clip, separate the shift cable from the control cable bracket.

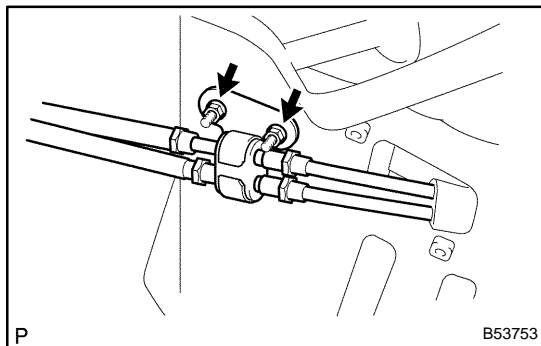

(c) Remove the 2 nuts and clamp.

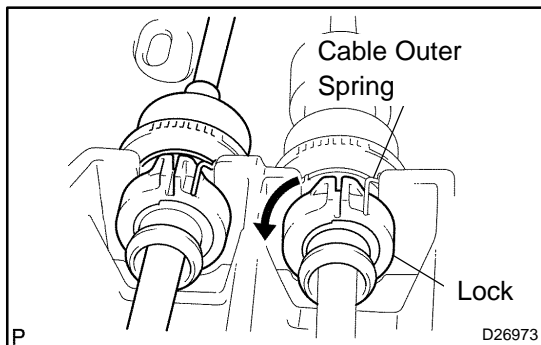

(d) Using a screwdriver, release the cable outer spring.

(e) Turn the lock, separate the shift cable from the shift lever retainer.

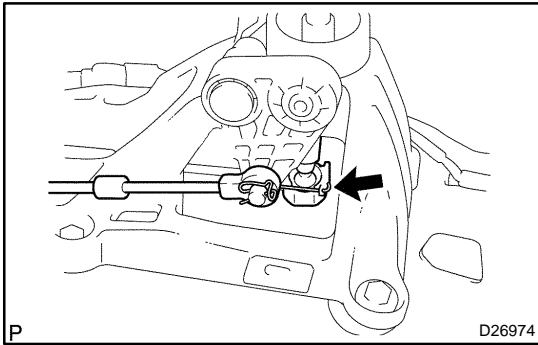

- (f) Separate the end of the shift cable from the shift lever assy.

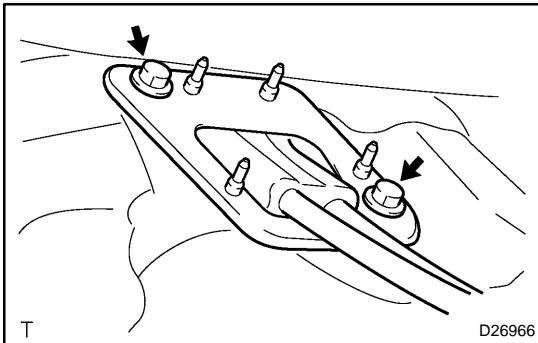

- (g) Remove the 2 bolts and retainer from the floor.
(h) Pull out the control cable assy from the floor.

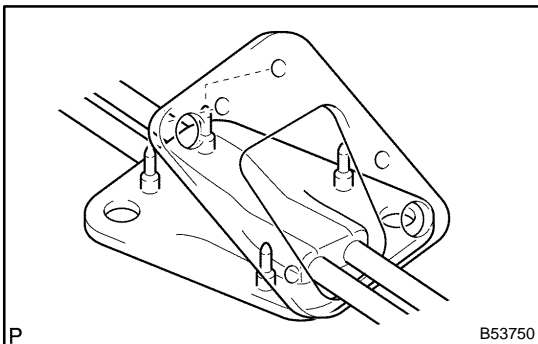

- (i) Remove the retainer from the grommet.

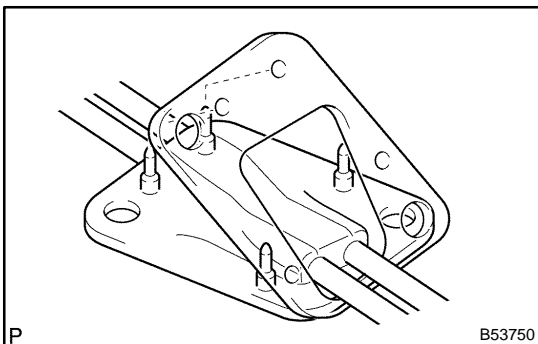

6. INSTALL FLOOR SHIFT CABLE TRANSMISSION CONTROL SHIFT

- (a) Put the control cable assy through the floor hole and retainer.
(b) Install the retainer to the grommet.

NOTICE:

Fit 4 projections of the grommet into 4 holes of the retainer.

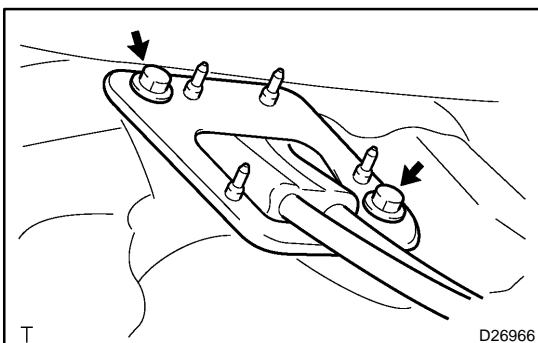

- (c) Install the control cable assy with the 2 bolts.
Torque: 5.0 N·m (51 kgf·cm, 44 in·lbf)

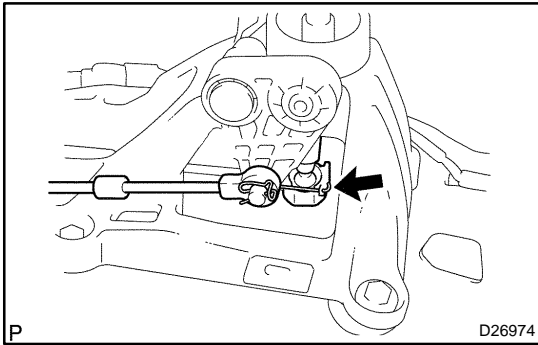

(d) Connect the end of the shift cable to the shift lever assy.

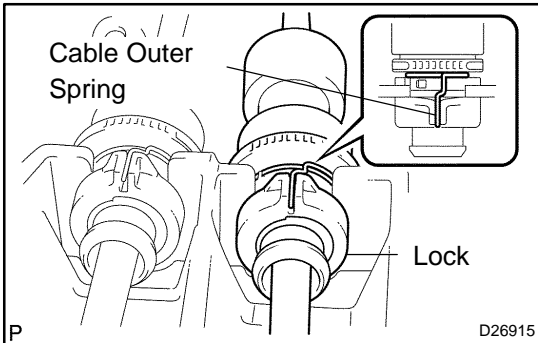

(e) Connect the shift cable to the retainer of shift lever assy, turn the lock.

NOTICE:

The projecting part of the lock should face upward when the shift cable is installed.

(f) Install the cable outer spring to the lock.

NOTICE:

Make sure that after installation the cable outer spring is moved to the place shown in the illustration.

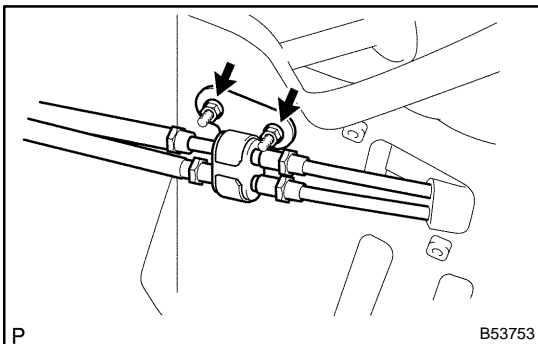

(g) Install the clamp with the 2 nuts.

Torque: 5.0 N·m (51 kgf·cm, 44 in·lbf)

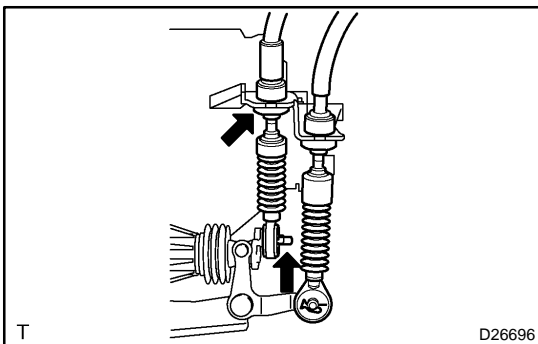

(h) Connect the shift cable to the control cable bracket, install a new clip.

(i) Connect the shift cable to the transaxle, install the washer and clip.

7. INSTALL FRONT FLOOR HEAT INSULATOR NO.1

(a) Install the heat insulator No.1 with the 3 nuts.

Torque: 5.5 N·m (56 kgf·cm, 49 in·lbf)

8. INSTALL EXHAUST PIPE ASSY (See page 15-2)

9. CONNECT AIR BAG SENSOR ASSY CENTER

(a) Install the airbag sensor assy center with the 3 bolts.

Torque: 17.5 N·m (178 kgf·cm, 13 ft·lbf)

10. INSPECT SRS WARNING LIGHT (See page 05-424)