

# FRONT DIFFERENTIAL OIL SEAL (ATM)

400LP-02

## REPLACEMENT

1. REMOVE FRONT WHEELS
2. REMOVE ENGINE UNDER COVER RH
3. REMOVE ENGINE UNDER COVER LH
4. DRAIN AUTOMATIC TRANSAXLE FLUID
  - (a) Remove the drain plug, gasket and drain ATF.
  - (b) Install a new gasket and drain plug.

**Torque: 17.5 N·m (178 kgf·cm, 13 ft·lbf)**
5. REMOVE FRONT DRIVE SHAFT ASSY RH (See page 30-6)
6. REMOVE FRONT DRIVE SHAFT ASSY LH (See page 30-6)

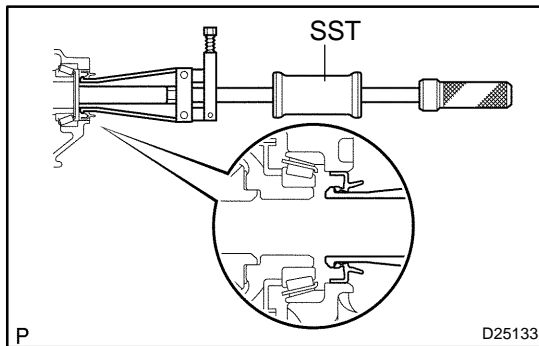

### 7. REMOVE TRANSAXLE HOUSING OIL SEAL(RH)

- (a) Using SST, pull out the oil seal.  
SST 09308-00010

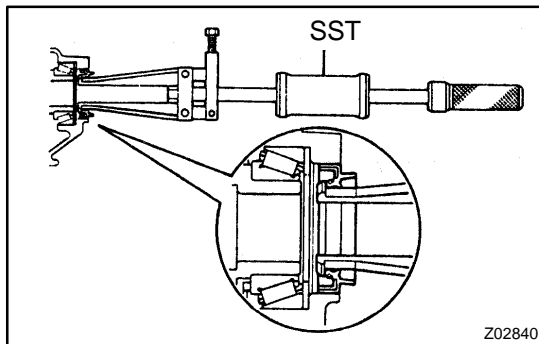

### 8. REMOVE TRANSAXLE CASE OIL SEAL(LH)

- (a) Using SST, pull out the oil seal.  
SST 09308-00010

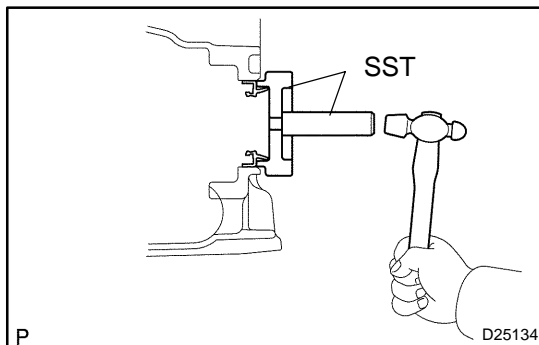

### 9. INSTALL TRANSAXLE HOUSING OIL SEAL(RH)

- (a) Using SST and a hammer, drive in a new oil seal.  
SST 09350-32014 (09351-32130, 09351-32150)  
**Oil seal drive in depth:**  
**2.0 ± 0.5 mm (0.079 ± 0.020 in.)**
- (b) Coat the lip of the oil seal with MP grease.

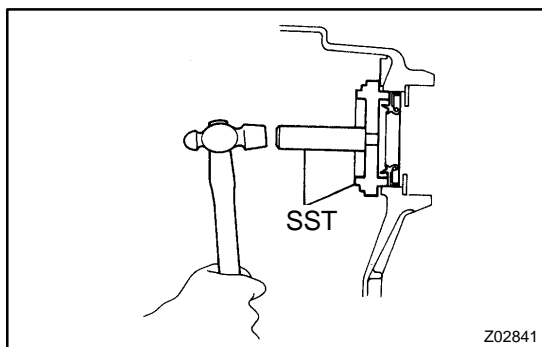
**10. INSTALL TRANSAXLE CASE OIL SEAL(LH)**

- (a) Using SST and a hammer, drive in a new oil seal.  
SST 09350-32014 (09351-32111, 09351-32130)  
**Oil seal drive in depth:**  
**5.3 ± 0.5 mm (0.209 ± 0.020 in.)**
- (b) Coat the lip of the oil seal with MP grease.

11. **INSTALL FRONT DRIVE SHAFT ASSY LH (See page 30-6)**
12. **INSTALL FRONT DRIVE SHAFT ASSY RH (See page 30-6)**
13. **INSTALL ENGINE UNDER COVER LH**
14. **INSTALL ENGINE UNDER COVER RH**
15. **INSTALL FRONT WHEELS**  
Torque: 103 N·m (1050 kgf·cm, 76 ft·lbf)
16. **ADD AUTOMATIC TRANSMAXLE FLUID**
17. **INSPECT AUTOMATIC TRANSMAXLE FLUID (See page 40-2)**
18. **INSPECT AND ADJUST FRONT WHEEL ALIGNMENT (See page 26-5)**
19. **CHECK ABS SPEED SENSOR SIGNAL (W/ ABS) (See page 05-297)**