

# BRAKE BOOSTER ASSY ON-VEHICLE INSPECTION

320IF-01

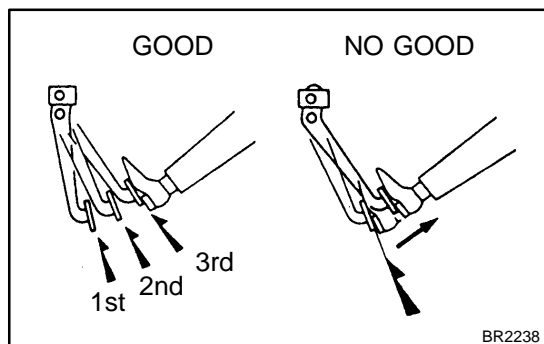

## 1. INSPECT BRAKE BOOSTER

### (a) Airtightness check.

- (1) Start the engine and stop it after 1 or 2 minutes. Depress the brake pedal several times slowly.

#### HINT:

If the pedal goes down farthest at the 1st time, but gradually rises after the 2nd or 3rd time, the booster is airtight.

- (2) Depress the brake pedal while the engine is running, and stop the engine with the pedal depressed.

#### HINT:

If there is no change in the pedal reserve distance after holding the pedal for 30 seconds, the booster is airtight.

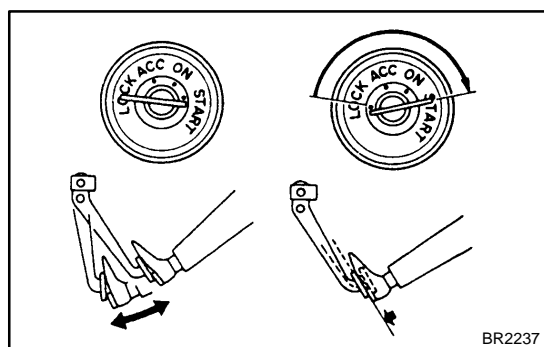

### (b) Operating check.

- (1) Depress the brake pedal several times with the ignition switch OFF and check that there is no change in the pedal reserve distance.
- (2) Depress the brake pedal and start the engine.

#### HINT:

If the pedal goes down slightly, operation is normal.

## 2. INSPECT VACUUM CHECK VALVE

### (a) Check vacuum check valve.

- (1) Slide the clip and disconnect the vacuum hose.
- (2) Remove the vacuum check valve.

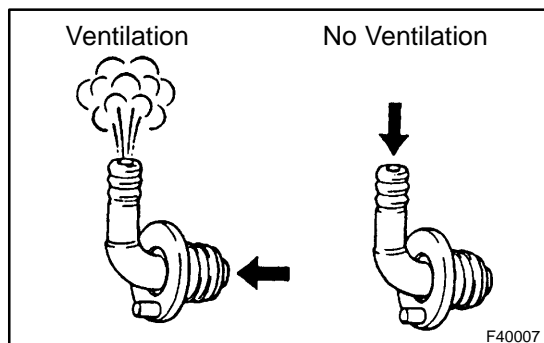

- (3) Check that there is ventilation from the booster to engine, and no ventilation from the engine to the booster.
- (4) If any fault is found, replace the vacuum check valve.