

WATER PUMP ASSY REPLACEMENT

160C9-01

1. REMOVE ENGINE UNDER COVER RH
2. DRAIN COOLANT (See page 16-7)

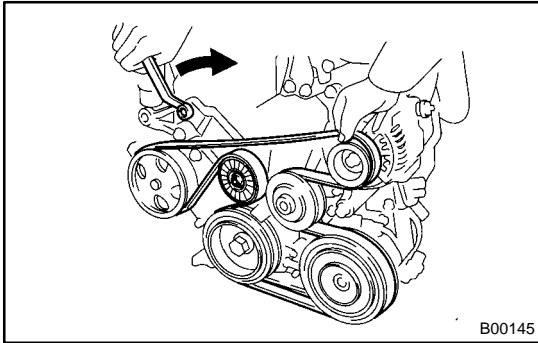

3. REMOVE FAN AND GENERATOR V BELT
(See page 14-4)

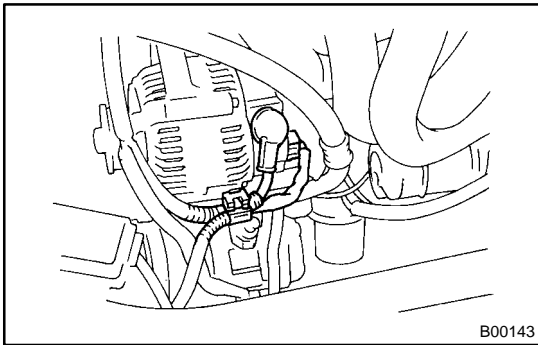

4. REMOVE GENERATOR ASSY
 - (a) Disconnect the wire clamp from the wire clip on the rectifier end frame.
 - (b) Remove the rubber cap and nut, and disconnect the alternator wire.
 - (c) Disconnect the alternator connector.

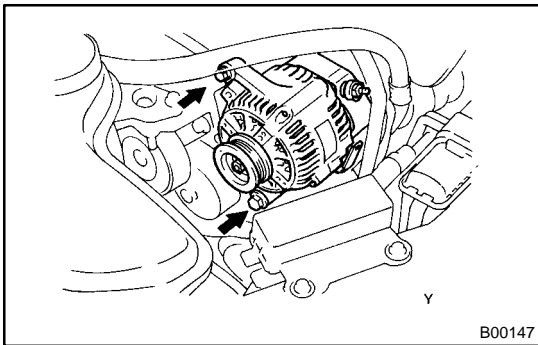

- (d) Remove the 2 bolts and alternator.

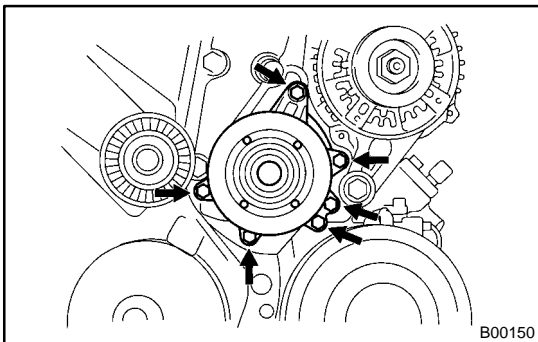

5. REMOVE WATER PUMP ASSY
 - (a) Remove the 6 bolts, water pump and O-ring.

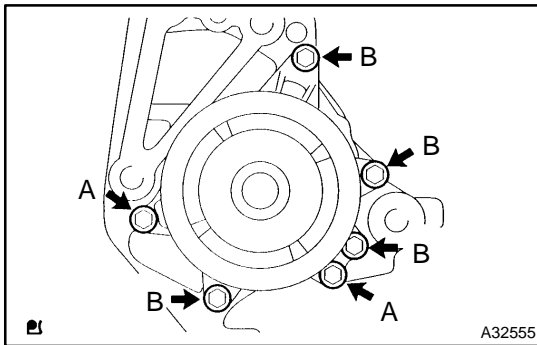
**6. INSTALL WATER PUMP ASSY**

- (a) Place a new O-ring on the timing chain cover.
- (b) Install the water pump with the 6 bolts.

Torque:**Bolt A 9.0 N·m (92 kgf·cm, 80 in·lbf)****Bolt B 11 N·m (113 kgf·cm, 8 ft·lbf)****7. INSTALL GENERATOR ASSY****Torque:****12 mm head 25 N·m (250 kgf·cm, 18 ft·lbf)****14 mm head 54 N·m (550 kgf·cm, 39 ft·lbf)**

8. **ADD COOLANT** (See page 16-7)
9. **CHECK ENGINE COOLANT LEAK** (See page 16-7)