

CHAIN SUB-ASSY COMPONENTS

1400G-01

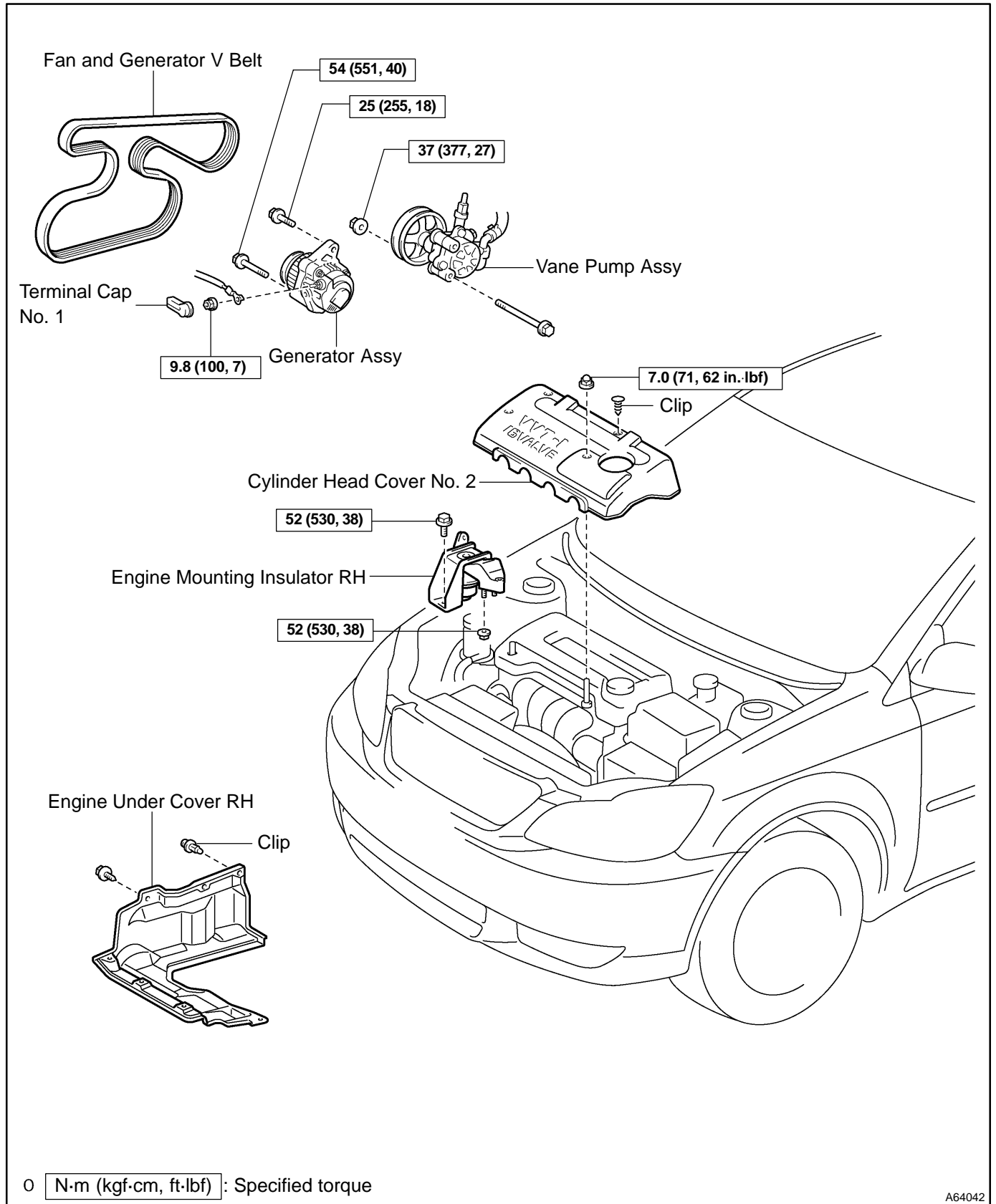

A64042

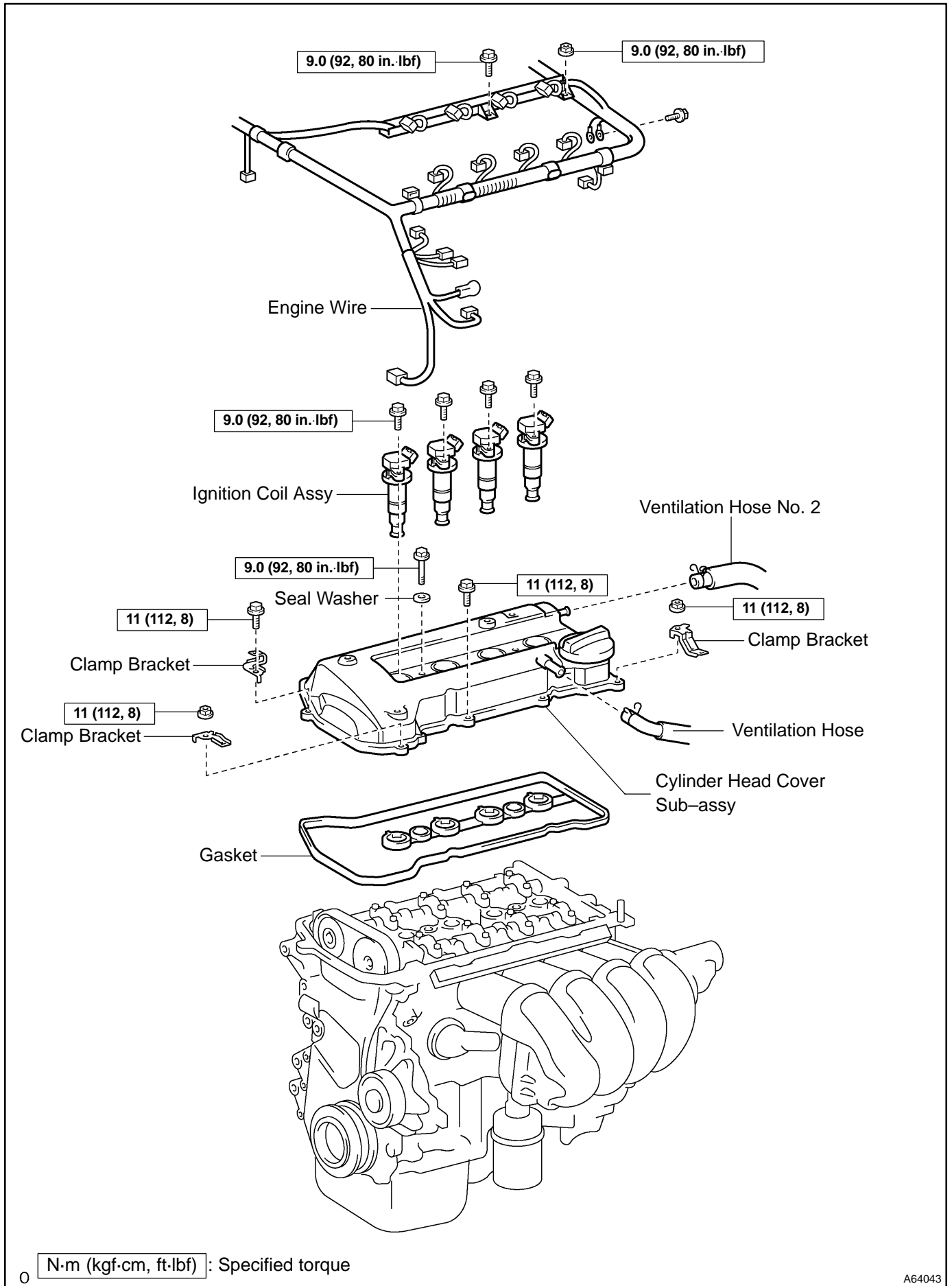

ENGINE MECHANICAL - CHAIN SUB-ASSY

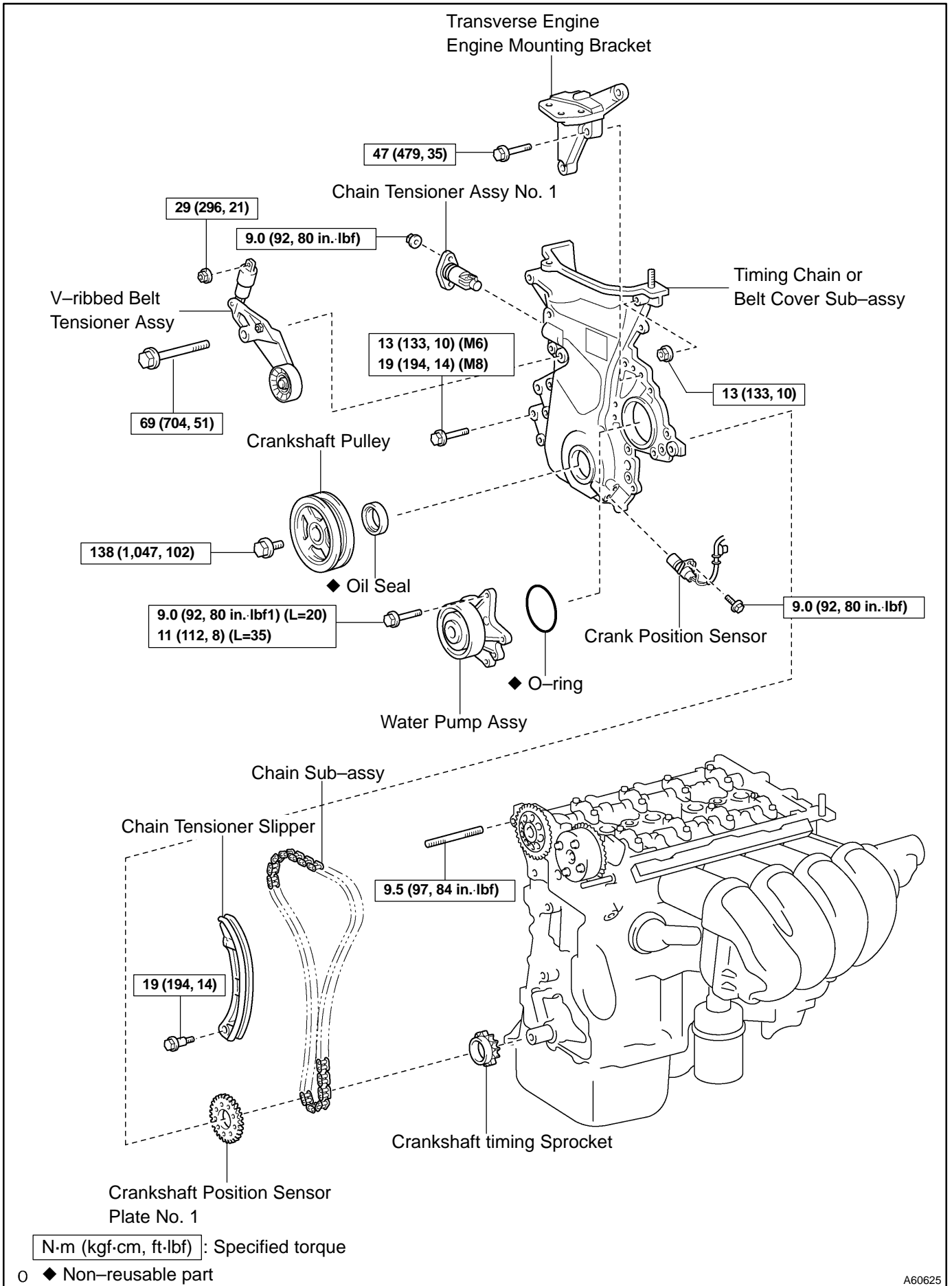

A60625