

INSPECTION

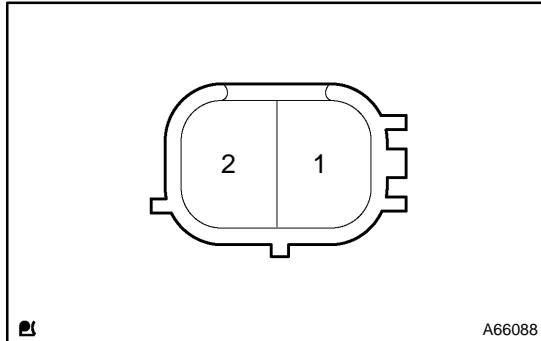

1. FUEL INJECTOR ASSY

- (a) Inspect injector resistance.
 - (1) Using an ohmmeter, measure the resistance between the terminals.

Resistance: 13.4 – 14.2 Ω at 20°C (68°F)

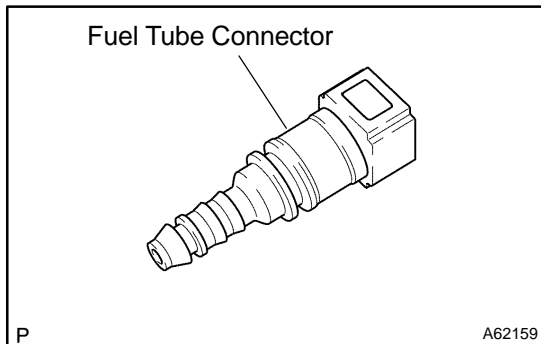

- (b) Inspect injector inspection

CAUTION:

Keep injector clear of sparks during the test.

- (1) Purchase a new fuel tube, and take out the fuel tube connector from its tube.

HINT:

Part No. 23901-0D010

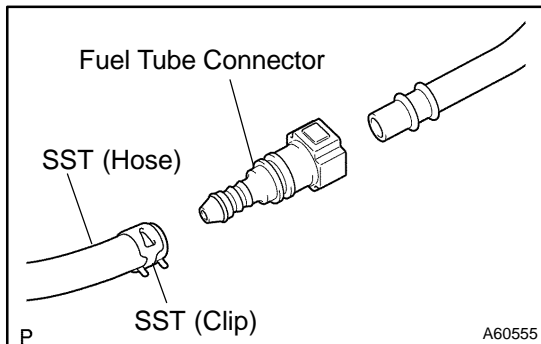

- (2) Connect SST and fuel tube connector to the fuel pipe.

SST 09268-41047 (90467-13001, 95336-08070)

CAUTION:

Perform connecting operations of the fuel tube connector (quick type) after observing the precautions.

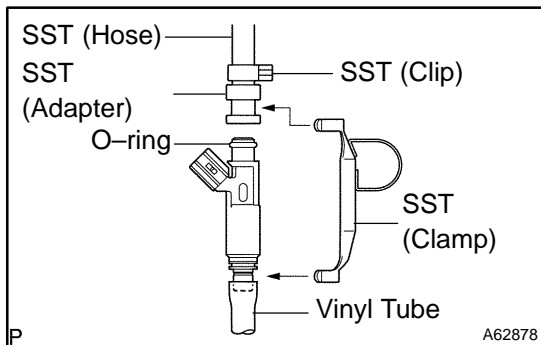

- (3) Install an O-ring to the fuel injector.
- (4) Connect SST (union and hose) to fuel the injector, and hold the fuel injector to prevent gasoline from splashing out. (See page 11-1)

SST 09268-41047 (90467-13001, 95336-08070, 09268-41110, 09268-41300)

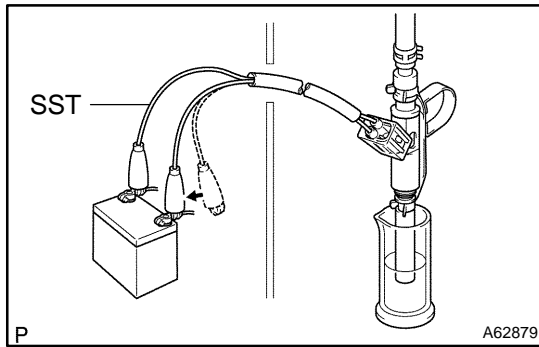

- (5) Put the fuel injector into a graduated cylinder.

HINT:

Install a suitable vinyl tube onto the injector to prevent gasoline from splashing out.

- (6) Operate the fuel pump.

- (7) Connect SST to the connector of fuel injector.

SST 09842-30080

- (8) Connect SST to the battery for 15 seconds, and measure the injection volume with a graduated cylinder. Test the each fuel injector 2 or 3 time.

Injection volume:

60 – 73 cm³ (3.7 – 4.5 cu in.) per 15 seconds

Difference between each injector:

13 cm³ (0.8 cu in.) or less

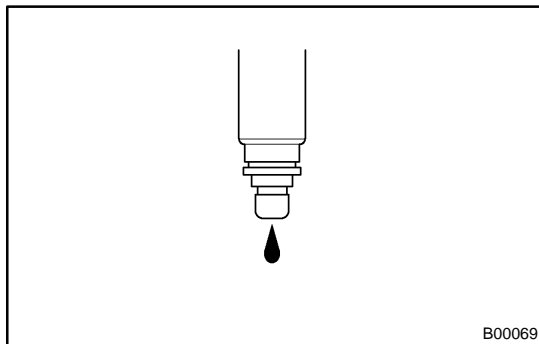

- (c) Inspect leakage

- (1) In the condition above, disconnect the test probes of the from the battery, and check the fuel leakage from the fuel injector.

Fuel drop: 1 drop or less per 12 minutes

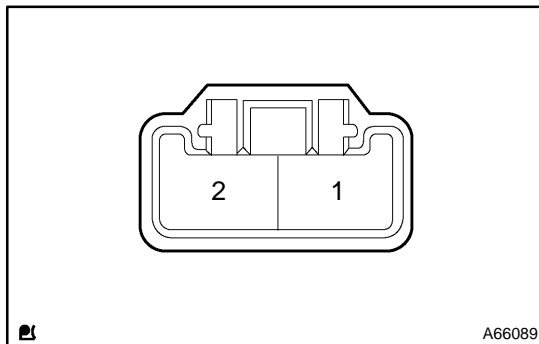
**2. FUEL PUMP**

- (a) Inspect fuel pump resistance.

- (1) Using an ohmmeter, measure the resistance between the terminals.

Resistance: 0.2 – 3.0 Ω at 20°C (68°F)

- (b) Inspect fuel pump operation

- (1) Apply battery voltage to both terminals. Check that the pump operates.

NOTICE:

- **These tests must be done quickly (within 10 seconds) to prevent the coil from burning out.**
- **Keep fuel pump as far away from the battery as possible.**
- **Always do the switching at the battery side.**