

DTC	B0135/73	SHORT IN P/T SQUIB (LH) CIRCUIT
------------	-----------------	--

CIRCUIT DESCRIPTION

The P/T squib (LH) circuit consists of the airbag sensor assy center and seat belt pretensioner (LH). It causes the SRS to deploy when the SRS deployment conditions are satisfied.

DTC B0135/73 is recorded when a short is detected in the P/T squib (LH) circuit.

DTC No.	DTC Detecting Condition	Trouble Area
B0135/73	<ul style="list-style-type: none"> • Short circuit between PL+ wire harness and PL- wire harness of squib • P/T squib (LH) malfunction • Airbag sensor assy center malfunction 	<ul style="list-style-type: none"> • Seat belt pretensioner (LH) • Airbag sensor assy center • Instrument panel wire No.3

WIRING DIAGRAM

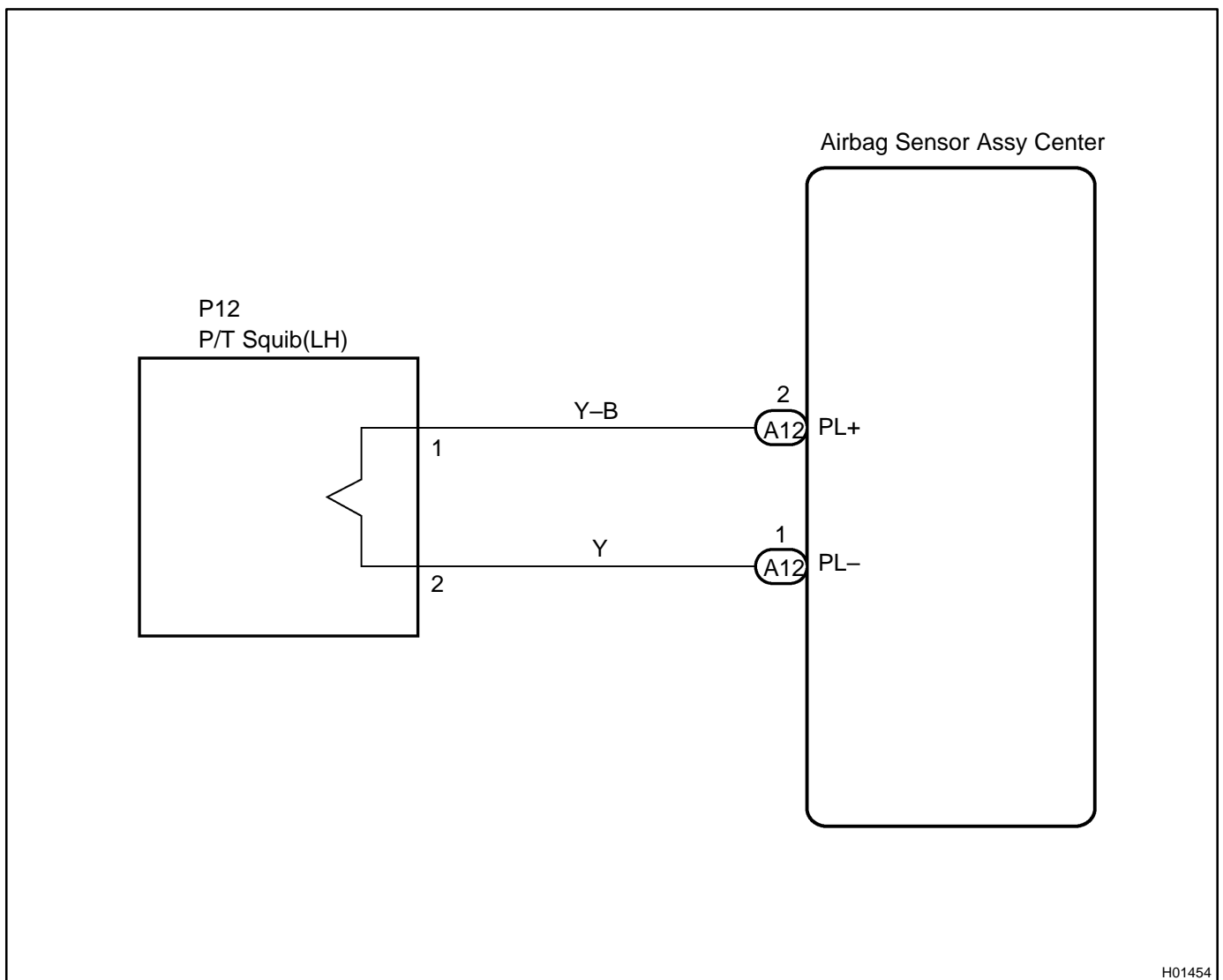

INSPECTION PROCEDURE

1	CHECK P/T SQUIB(LH) CIRCUIT(AIRBAG SENSOR ASSY CENTER - FRONT SEAT OUTER BELT ASSY LH)
----------	---

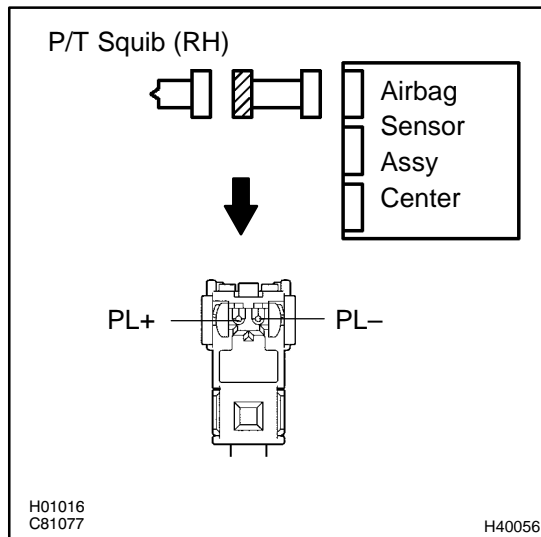

- (a) Disconnect the negative (-) terminal cable from the battery, and wait at least for 90 seconds.
- (b) Disconnect the connectors between the airbag sensor assy center and the seat belt pretensioner (LH).

HINT:

Make sure that the connector is not damaged (The lock button is not disengaged, or the claw of the lock is not deformed or damaged). If the damage is found, replace the wire harness.

- (c) Release the airbag activation prevention mechanism of the connector (on the airbag sensor assy center side) between the airbag sensor assy center and the seat belt pretensioner (LH) (See page 05-424).
- (d) For the connector (on the seat belt pretensioner side) between the airbag sensor assy center and the seat belt pretensioner (LH), measure the resistance between PL+ and PL-.

OK:

Resistance: 1 MΩ or Higher

NG

REPAIR OR REPLACE INSTRUMENT PANEL WIRE NO.3(AIRBAG SENSOR ASSY CENTER - FRONT SEAT OUTER BELT ASSY LH)

OK

2 CHECK AIR BAG SENSOR ASSY CENTER

SST 09843-18040

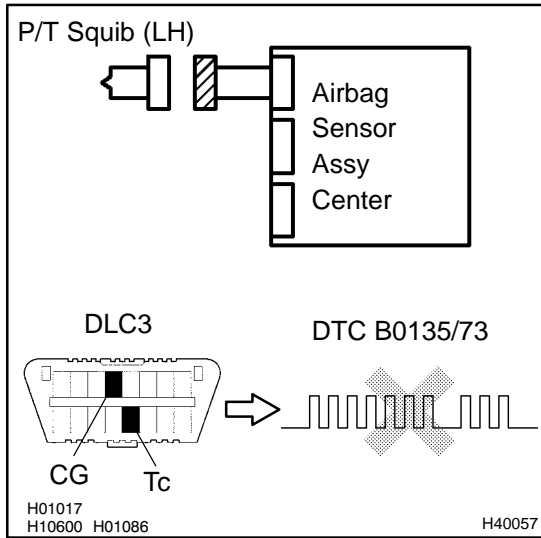

- (a) Connect the connector to the airbag sensor assy center.
- (b) Connect the negative (-) terminal cable to the battery, and wait at least for 2 seconds.
- (c) Turn the ignition switch to ON, and wait at least for 20 seconds.
- (d) Clear the DTC stored in memory (See page 05-424).
- (e) Turn the ignition switch to LOCK, and wait at least for 20 seconds.
- (f) Turn the ignition switch to ON, and wait at least for 20 seconds.
- (g) Check the DTC (See page 05-424).

OK:

DTC B0135/73 is not output.

HINT:

Codes other than code B0135/73 may be output at this time, but they are not relevant to this check.

NG → **REPLACE AIR BAG SENSOR ASSY CENTER**

OK

3 CHECK P/T SQUIB (LH)

SST 09843-18040

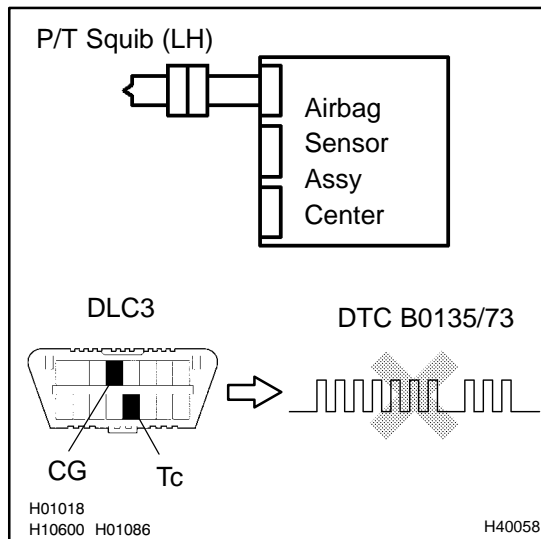

- (a) Turn the ignition switch to LOCK.
- (b) Disconnect the negative (-) terminal cable from the battery, and wait at least for 90 seconds.
- (c) Connect the seat belt pretensioner (LH) connector.
- (d) Connect the negative (-) terminal cable to the battery, and wait at least for 2 seconds.
- (e) Turn the ignition switch to ON, and wait at least for 20 seconds.
- (f) Clear the DTC stored in memory (See page 05-424).
- (g) Turn the ignition switch to LOCK, and wait at least for 20 seconds.
- (h) Turn the ignition switch to ON, and wait at least for 20 seconds.
- (i) Check the DTC (See page 05-424).

OK:**DTC B0135/73 is not output.**

HINT:

Codes other than code B0135/73 may be output at this time, but they are not relevant to this check.

NG**REPLACE FRONT SEAT OUTER BELT ASSY LH****OK****USE SIMULATION METHOD TO CHECK**