

DTC	B0132/61	SHORT IN P/T SQUIB (RH) CIRCUIT (TO GROUND)
------------	-----------------	--

CIRCUIT DESCRIPTION

The P/T squib (RH) circuit consists of the airbag sensor assy center and seat belt pretensioner (RH). It causes the SRS to deploy when the SRS deployment conditions are satisfied.

DTC B0132/61 is recorded when a ground short is detected in the P/T squib (RH) circuit.

DTC No.	DTC Detecting Condition	Trouble Area
B0132/61	<ul style="list-style-type: none"> • Short circuit in P/T squib (RH) wire harness (to ground) • P/T squib (RH) malfunction • Airbag sensor assy center malfunction 	<ul style="list-style-type: none"> • Seat belt pretensioner (RH) • Airbag sensor assy center • Instrument panel wire No.3

WIRING DIAGRAM

See page 05-494.

INSPECTION PROCEDURE

1	CHECK P/T SQUIB(RH) CIRCUIT(AIRBAG SENSOR ASSY CENTER - FRONT SEAT OUTER BELT ASSY RH)
----------	---

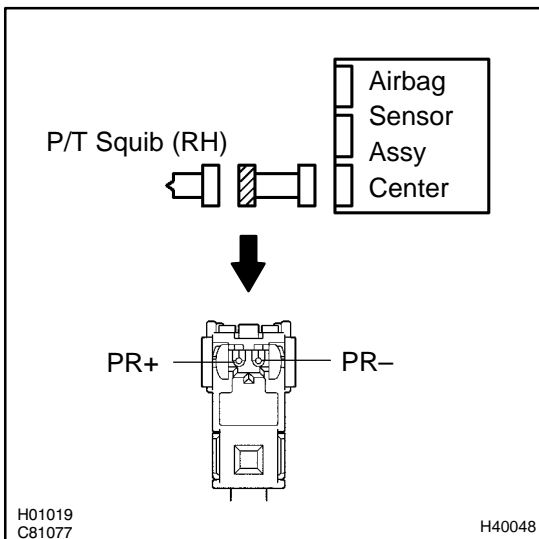

- (a) Disconnect the negative (-) terminal cable from the battery, and wait at least for 90 seconds.
- (b) Disconnect the connectors between the airbag sensor assy center and the seat belt pretensioner (RH).
- (c) For the connector (on the seat belt pretensioner side) between the airbag sensor assy center and the seat belt pretensioner (RH), measure the resistance between PR+ and body ground.

OK:

Resistance: 1 MΩ or Higher

NG	REPAIR OR REPLACE INSTRUMENT PANEL WIRE NO.3(AIRBAG SENSOR ASSY CENTER - FRONT SEAT OUTER BELT ASSY RH)
-----------	--

OK

2 CHECK AIR BAG SENSOR ASSY CENTER

SST 09843-18040

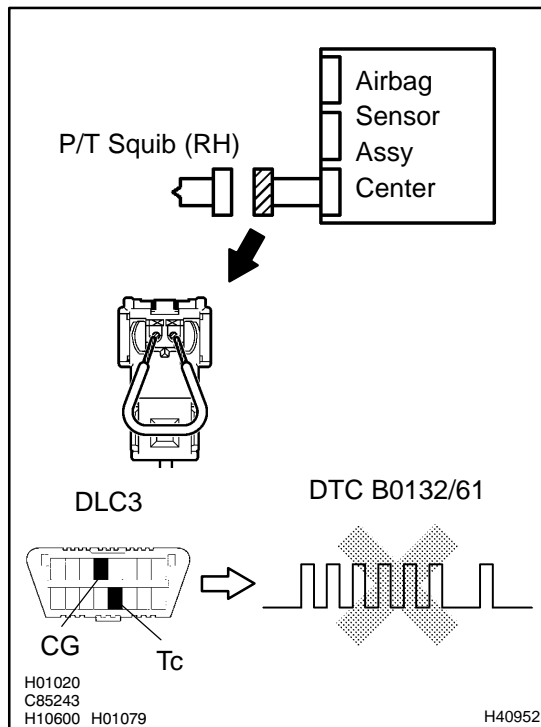

- (a) Connect the connector to the airbag sensor assy center.
- (b) Using a service wire, connect PR+ and PR- of the connector (on the seat belt pretensioner side) between the airbag sensor assy center and the seat belt pretensioner (RH).
- (c) Connect the negative (-) terminal cable to the battery, and wait at least for 2 seconds.
- (d) Turn the ignition switch to ON, and wait at least for 20 seconds.
- (e) Clear the DTC stored in memory (See page 05-424).
- (f) Turn the ignition switch to LOCK, and wait at least for 20 seconds.
- (g) Turn the ignition switch to ON, and wait at least for 20 seconds.
- (h) Check the DTC (See page 05-424).

OK:**DTC B0132/61 is not output.****HINT:**

Codes other than code B0132/61 may be output at this time, but they are not relevant to this check.

NG**REPLACE AIR BAG SENSOR ASSY CENTER****OK**

3 CHECK P/T SQUIB (RH)

SST 09843-18040

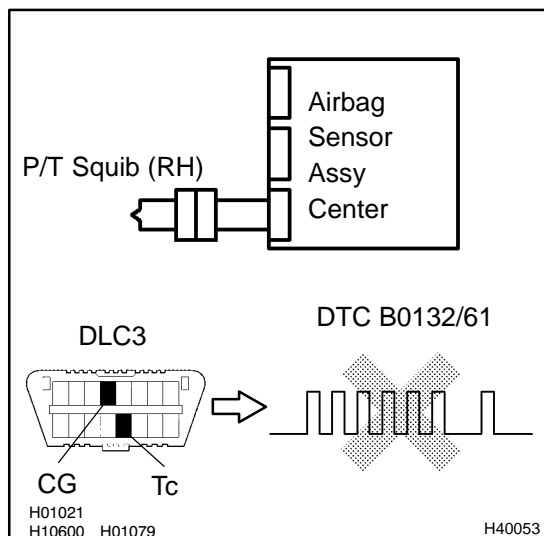

- (a) Turn the ignition switch to LOCK.
- (b) Disconnect the negative (-) terminal cable from the battery, and wait at least for 90 seconds.
- (c) Connect the seat belt pretensioner (RH) connector.
- (d) Connect the negative (-) terminal cable to the battery, and wait at least for 2 seconds.
- (e) Turn the ignition switch to ON, and wait at least for 20 seconds.
- (f) Clear the DTC stored in memory (See page 05-424).
- (g) Turn the ignition switch to LOCK, and wait at least for 20 seconds.
- (h) Turn the ignition switch to ON, and wait at least for 20 seconds.
- (i) Check the DTC (See page 05-424).

OK:**DTC B0132/61 is not output.**

HINT:

Codes other than code B0132/61 may be output at this time, but they are not relevant to this check.

NG**REPLACE FRONT SEAT OUTER BELT ASSY RH****OK**

4 USE SIMULATION METHOD TO CHECK

NG**Go to step 1****OK****REPLACE ALL SRS COMPONENTS INCLUDING THE WIRE HARNESS**