

DTC	B0117/45	SHORT IN SIDE SQUIB (LH) CIRCUIT (TO GROUND)
------------	-----------------	---

CIRCUIT DESCRIPTION

The side squib (LH) circuit consists of the airbag sensor assy center and front seat airbag assy (LH). It causes the SRS to deploy when the SRS deployment conditions are satisfied.

DTC B0117/45 is recorded when a ground short is detected in the side squib (LH) circuit.

DTC No.	DTC Detecting Condition	Trouble Area
B0117/45	<ul style="list-style-type: none"> • Short circuit in side squib (LH) wire harness (to ground) • Side squib (LH) malfunction • Airbag sensor assy center malfunction 	<ul style="list-style-type: none"> • Front seat airbag assy (LH) • Airbag sensor assy center • Instrument panel wire No.3

WIRING DIAGRAM

See page 05-478.

INSPECTION PROCEDURE

1	CHECK SIDE SQUIB(LH) CIRCUIT(AIRBAG SENSOR ASSY CENTER - FRONT SEAT AIRBAG ASSY LH)
----------	--

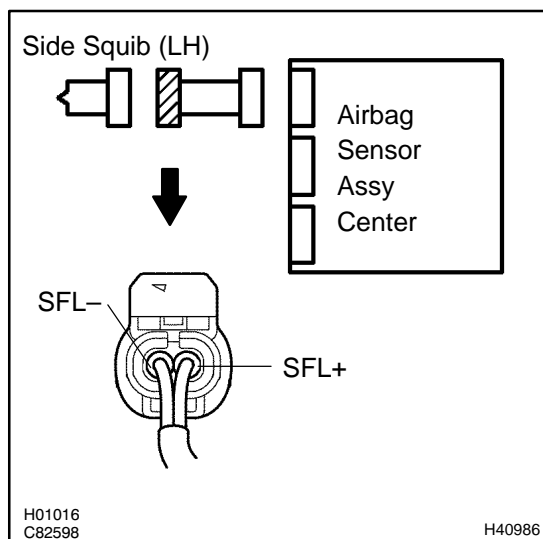

- (a) Disconnect the negative (-) terminal cable from the battery, and wait at least for 90 seconds.
- (b) Disconnect the connectors between the airbag sensor assy center and the front seat airbag assy (LH).
- (c) For the connector (on the front seat airbag assy side) between the airbag sensor assy center and the front seat airbag assy (LH), measure the resistance between SFL+ and body ground.

OK:

Resistance: 1 MΩ or Higher

NG	REPAIR OR REPLACE INSTRUMENT PANEL WIRE NO.3(AIRBAG SENSOR ASSY CENTER - FRONT SEAT AIRBAG ASSY LH)
-----------	--

OK

2 CHECK AIR BAG SENSOR ASSY CENTER

SST 09843-18040

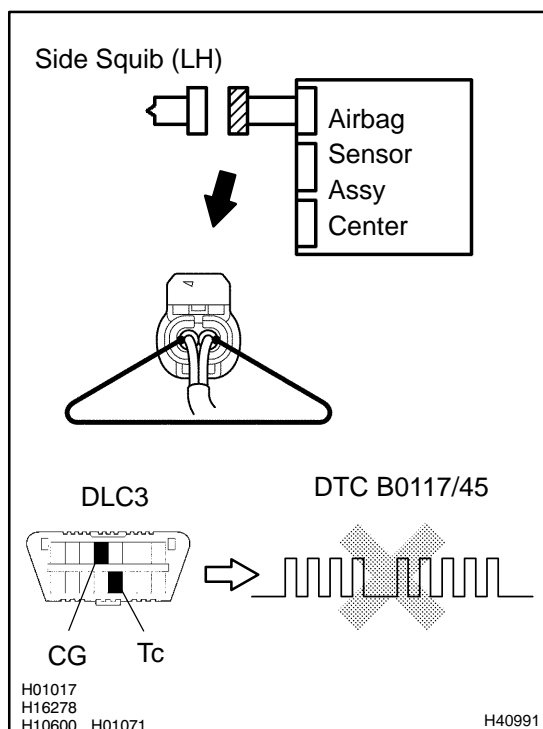

- Connect the connector to the airbag sensor assy center.
- Using a service wire, connect SFL+ and SFL- of the connector (on the front seat airbag assy side) between the airbag sensor assy center and the front seat airbag assy (LH).
- Connect the negative (-) terminal cable to the battery, and wait at least for 2 seconds.
- Turn the ignition switch to ON, and wait at least for 20 seconds.
- Clear the DTC stored in memory (See page 05-424).
- Turn the ignition switch to LOCK, and wait at least for 20 seconds.
- Turn the ignition switch to ON, and wait at least for 20 seconds.
- Check the DTC (See page 05-424).

OK:**DTC B0117/45 is not output.****HINT:**

Codes other than code B0117/45 may be output at this time, but they are not relevant to this check.

NG**REPLACE AIR BAG SENSOR ASSY CENTER****OK**

3 CHECK SIDE SQUIB(LH)

SST 09843-18040

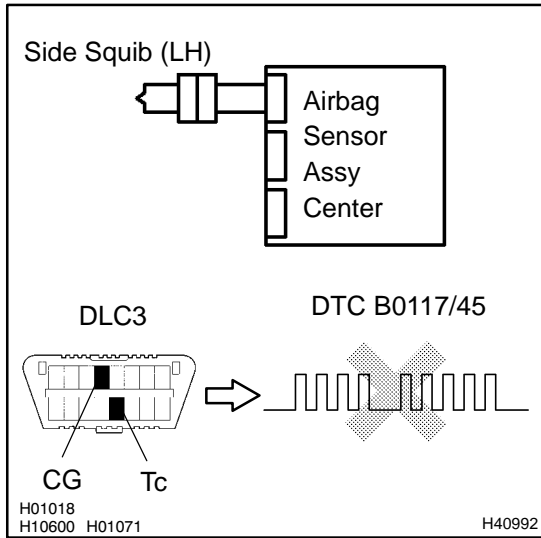

- (a) Turn the ignition switch to LOCK.
- (b) Disconnect the negative (-) terminal cable from the battery, and wait at least for 90 seconds.
- (c) Connect the front front seat airbag assy (LH) connector.
- (d) Connect the negative (-) terminal cable to the battery, and wait at least for 2 seconds.
- (e) Turn the ignition switch to ON, and wait at least for 20 seconds.
- (f) Clear the DTC stored in memory (See page 05-424).
- (g) Turn the ignition switch to LOCK, and wait at least for 20 seconds.
- (h) Turn the ignition switch to ON, and wait at least for 20 seconds.
- (i) Check the DTC (See page 05-424).

OK:

DTC B0117/45 is not output.

HINT:

Codes other than code B0117/45 may be output at this time, but they are not relevant to this check.

NG → **REPLACE SEPARATE TYPE FRONT SEAT BACK ASSY**

OK

4 USE SIMULATION METHOD TO CHECK

NG → **Go to step 1**

OK

REPLACE ALL SRS COMPONENTS INCLUDING THE WIRE HARNESS