

DTC	B1188/56	SHORT IN SQUIB (2ND STEP) CIRCUIT (TO B+)
------------	-----------------	--

CIRCUIT DESCRIPTION

The P squib (2nd step) circuit consists of the airbag sensor assy center and instrument panel passenger airbag assy.

It causes the SRS to deploy when the SRS deployment conditions are satisfied.

DTC B1188/56 is recorded when a B+ short is detected in the P squib (2nd step) circuit.

DTC No.	DTC Detecting Condition	Trouble Area
B1188/56	<ul style="list-style-type: none"> • Short circuit in P squib (2nd step) wire harness (to B+) • P squib (2nd step) malfunction • Airbag sensor assy center malfunction 	<ul style="list-style-type: none"> • Instrument panel passenger airbag assy (P squib, 2nd step) • Airbag sensor assy center • Instrument panel wire

WIRING DIAGRAM

See page 05-570.

INSPECTION PROCEDURE

1	CHECK P SQUIB CIRCUIT(AIRBAG SENSOR ASSY CENTER - INSTRUMENT PANEL PASSENGER AIRBAG ASSY)
----------	--

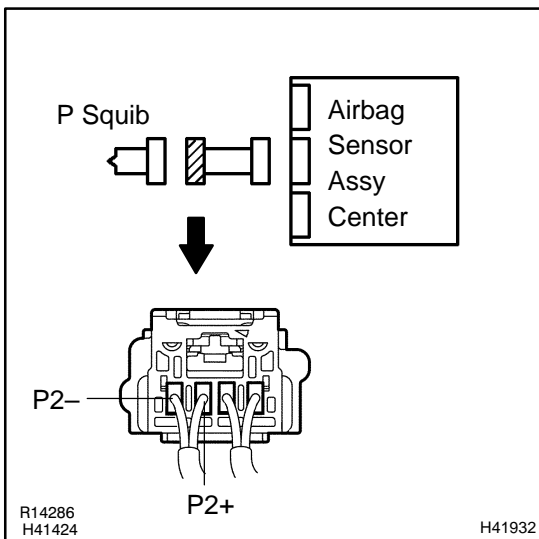

- (a) Disconnect the negative (-) terminal cable from the battery, and wait at least for 90 seconds.
- (b) Disconnect the connector between the airbag sensor assy center and the instrument panel passenger airbag assy.
- (c) Connect the negative (-) terminal cable to the battery, and wait at least for 2 seconds.
- (d) Turn the ignition switch to ON.
- (e) For the connector (on the instrument panel passenger airbag assy side) between the airbag sensor assy center and the instrument panel passenger airbag assy, measure the voltage between P2+ and body ground.

OK:

Voltage: Below 1 V

NG	REPAIR OR REPLACE INSTRUMENT PANEL WIRE
-----------	--

OK

2 CHECK AIR BAG SENSOR ASSY CENTER

SST 09843-18040

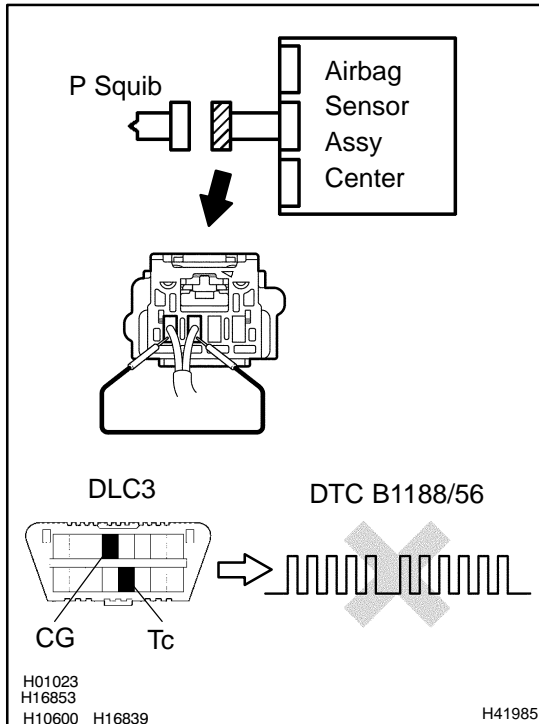

- (a) Turn the ignition switch to LOCK.
- (b) Disconnect the negative (-) terminal cable from the battery, and wait at least for 90 seconds.
- (c) Connect the connector to the airbag sensor assy center.
- (d) Using a service wire, connect P2+ and P2- of the connector (on the instrument panel passenger airbag assy side) between the airbag sensor assy center and the instrument panel passenger airbag assy.
- (e) Connect the negative (-) terminal cable to the battery, and wait at least for 2 seconds.
- (f) Turn the ignition switch to ON, and wait at least for 20 seconds.
- (g) Clear the DTC stored in memory (See page 05-424).
- (h) Turn the ignition switch to LOCK, and wait at least for 20 seconds.
- (i) Turn the ignition switch to ON, and wait at least for 20 seconds.
- (j) Check the DTC (See page 05-424).

OK:**DTC B1188/56 is not output.****HINT:**

Codes other than code B1188/56 may be output at this time, but they are not relevant to this check.

NG**REPLACE AIR BAG SENSOR ASSY CENTER****OK**

3 CHECK P SQUIB

SST 09843-18040

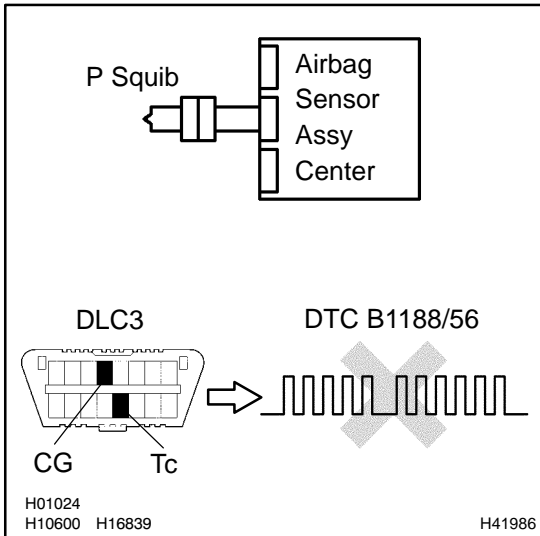

- (a) Turn the ignition switch to LOCK.
- (b) Disconnect the negative (-) terminal cable from the battery, and wait at least for 90 seconds.
- (c) Connect the instrument panel passenger airbag assy connector.
- (d) Connect the negative (-) terminal cable to the battery, and wait at least for 2 seconds.
- (e) Turn the ignition switch to ON, and wait at least for 20 seconds.
- (f) Clear the DTC stored in memory (See page 05-424).
- (g) Turn the ignition switch to LOCK, and wait at least for 20 seconds.
- (h) Turn the ignition switch to ON, and wait at least for 20 seconds.
- (i) Check the DTC (See page 05-424).

OK:

DTC B1188/56 is not output.

HINT:

Codes other than code B1188/56 may be output at this time, but they are not relevant to this check.

NG → **REPLACE INSTRUMENT PANEL PASSENGER AIR BAG ASSY**

OK

4 USE SIMULATION METHOD TO CHECK

NG → **Go to step 1**

OK

REPLACE ALL SRS COMPONENTS INCLUDING THE WIRE HARNESS