

DTC	B1186/58	OPEN IN P SQUIB (2ND STEP) CIRCUIT
------------	-----------------	---

CIRCUIT DESCRIPTION

The P squib (2nd step) circuit consists of the airbag sensor assy center and instrument panel passenger airbag assy.

It causes the SRS to deploy when the SRS deployment conditions are satisfied.

DTC B1186/58 is recorded when an open is detected in the P squib circuit.

DTC No.	DTC Detecting Condition	Trouble Area
B1186/58	<ul style="list-style-type: none"> • Open circuit in P2+ wire harness or P2- wire harness of squib (2nd step) • P squib (2nd step) malfunction • Airbag sensor assy center malfunction 	<ul style="list-style-type: none"> • Instrument panel passenger airbag assy (P squib, 2nd step) • Airbag sensor assy center • Instrument panel wire

WIRING DIAGRAM

See page 05-570.

INSPECTION PROCEDURE

1	CHECK P SQUIB CIRCUIT(AIRBAG SENSOR ASSY CENTER - INSTRUMENT PANEL PASSENGER AIRBAG ASSY)
----------	--

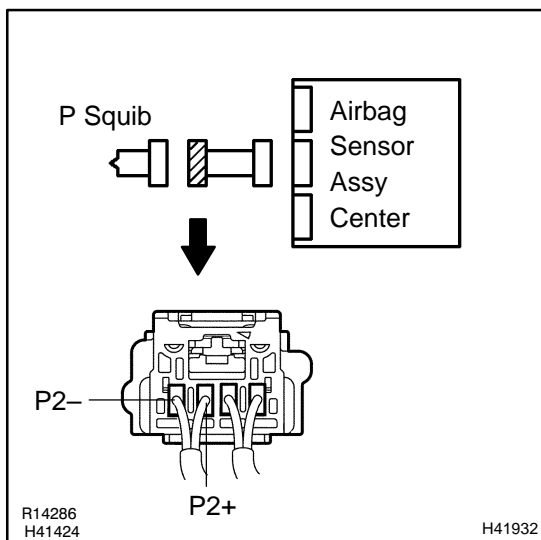

- (a) Disconnect the negative (-) terminal cable from the battery, and wait at least for 90 seconds.
- (b) Disconnect the connectors between the airbag sensor assy center and the instrument panel passenger airbag assy.
- (c) For the connector (on the instrument panel passenger airbag assy side) between the airbag sensor assy center and the instrument panel passenger airbag assy, measure the resistance between P2+ and P2-.

OK:
Resistance: Below 1 Ω

NG	REPAIR OR REPLACE INSTRUMENT PANEL WIRE
-----------	--

OK

2 CHECK AIR BAG SENSOR ASSY CENTER

SST 09843-18040

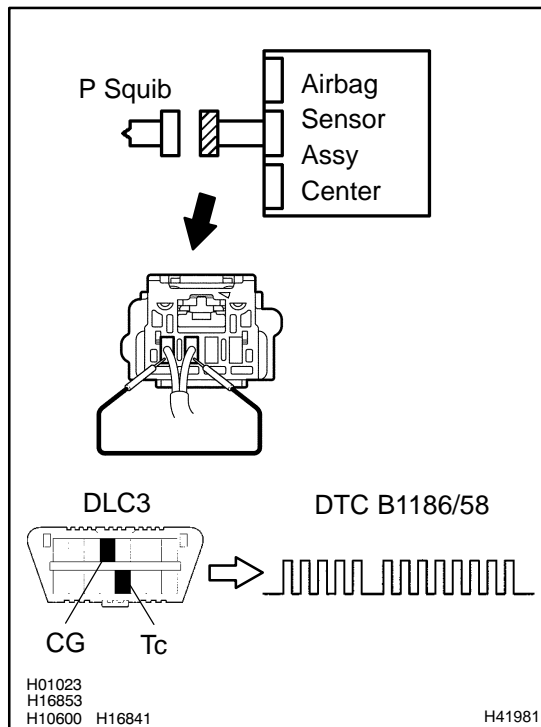

- (a) Connect the connector to the airbag sensor assy center.
- (b) Using a service wire, connect P2+ and P2- of the connector (on the instrument panel passenger airbag assy side) between the airbag sensor assy center and the instrument panel passenger airbag assy.
- (c) Connect the negative (-) terminal cable to the battery, and wait at least for 2 seconds.
- (d) Turn the ignition switch to ON, and wait at least for 20 seconds.
- (e) Clear the DTC stored in memory (See page 05-424).
- (f) Turn the ignition switch to LOCK, and wait at least for 20 seconds.
- (g) Turn the ignition switch to ON, and wait at least for 20 seconds.
- (h) Check the DTC (See page 05-424).

OK:**DTC B1186/58 is not output.****HINT:**

Codes other than code B1186/58 may be output at this time, but they are not relevant to this check.

NG**REPLACE AIR BAG SENSOR ASSY CENTER****OK**

3 CHECK P SQUIB

SST 09843-18040

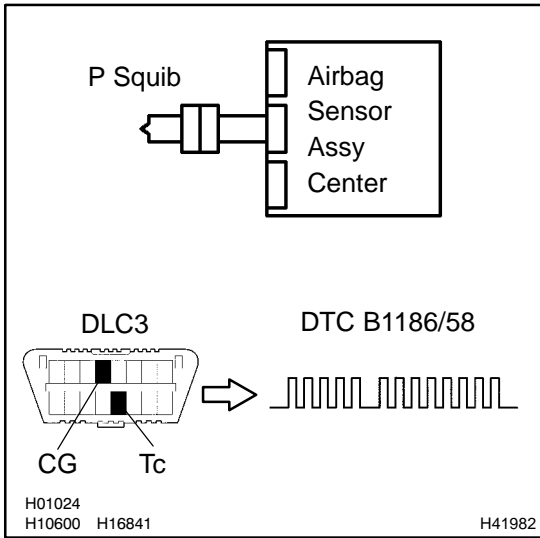

- (a) Turn the ignition switch to LOCK.
- (b) Disconnect the negative (-) terminal cable from the battery, and wait at least for 90 seconds.
- (c) Connect the instrument panel passenger airbag assy connector.
- (d) Connect the negative (-) terminal cable to the battery, and wait at least for 2 seconds.
- (e) Turn the ignition switch to ON, and wait at least for 20 seconds.
- (f) Clear the DTC stored in memory (See page 05-424).
- (g) Turn the ignition switch to LOCK, and wait at least for 20 seconds.
- (h) Turn the ignition switch to ON, and wait at least for 20 seconds.
- (i) Check the DTC (See page 05-424).

OK:

DTC B1186/58 is not output.

HINT:

Codes other than code B1186/58 may be output at this time, but they are not relevant to this check.

NG → **REPLACE INSTRUMENT PANEL PASSENGER AIR BAG ASSY**

OK

USE SIMULATION METHOD TO CHECK