

DTC	B1181/18	OPEN IN D SQUIB (2ND STEP) CIRCUIT
------------	-----------------	---

CIRCUIT DESCRIPTION

The D squib circuit consists of the airbag sensor assy center, spiral cable sub-assy and horn button assy. It causes the SRS to deploy when the SRS deployment conditions are satisfied.

DTC B1181/18 is recorded when an open is detected in the D squib circuit (2nd step).

DTC No.	DTC Detecting Condition	Trouble Area
B1181/18	<ul style="list-style-type: none"> • Open circuit in D+ wire harness or D- wire harness of squib • D squib (2nd step) malfunction • Spiral cable sub-assy malfunction • Airbag sensor assy center malfunction 	<ul style="list-style-type: none"> • Horn button assy (D squib, 2nd step) • Spiral cable sub-assy • Airbag sensor assy center • Instrument panel wire

WIRING DIAGRAM

See page 05-554.

INSPECTION PROCEDURE

1	CHECK D SQUIB CIRCUIT(AIRBAG SENSOR ASSY CENTER – HORN BUTTON ASSY)
----------	--

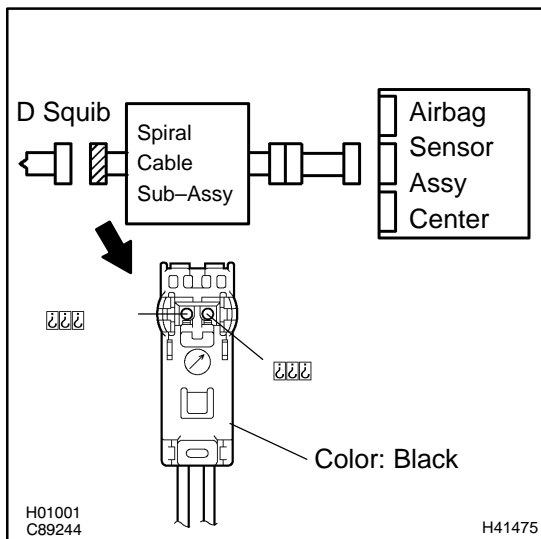

- (a) Disconnect the negative (-) terminal cable from the battery, and wait at least for 90 seconds.
- (b) Disconnect the connectors between the horn button assy and the airbag sensor assy center.
- (c) For the black connector (on the spiral cable sub-assy side) between the horn button assy and the spiral cable sub-assy, measure the resistance between D2+ and D2-.

OK:

Resistance: Below 1 Ω

NG	Go to step 4
-----------	---------------------

OK

2 CHECK AIR BAG SENSOR ASSY CENTER

SST 09843-18040

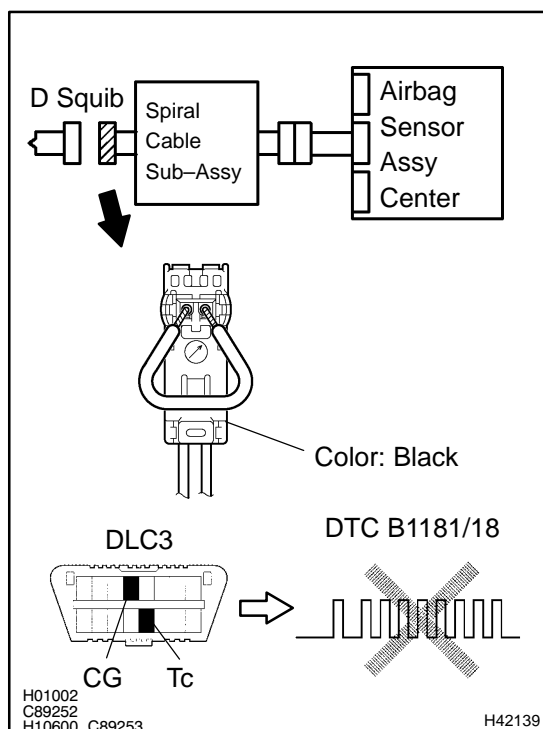

- Connect the connector to the airbag sensor assy center.
- Using a service wire, connect D2+ and D2- of the black connector (on the spiral cable sub-assy side) between the horn button assy and the spiral cable sub-assy.
- Connect the negative (-) terminal cable to the battery, and wait at least for 2 seconds.
- Turn the ignition switch to ON, and wait at least for 20 seconds.
- Clear the DTC stored in memory (See page 05-424).
- Turn the ignition switch to LOCK, and wait at least for 20 seconds.
- Turn the ignition switch to ON, and wait at least for 20 seconds.
- Check the DTC (See page 05-424).

OK:**DTC B1181/18 is not output.**

HINT:

Codes other than code B1181/18 may be output at this time, but they are not relevant to this check.

NG**REPLACE AIR BAG SENSOR ASSY CENTER****OK**

3 CHECK D SQUIB

SST 09843-18040

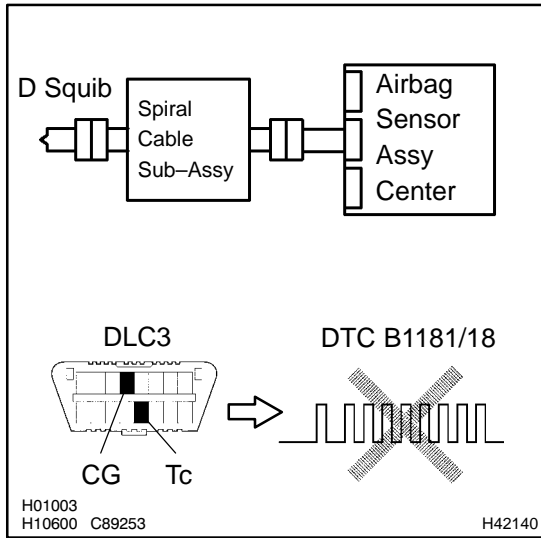

- (a) Turn the ignition switch to LOCK.
- (b) Disconnect the negative (-) terminal cable from the battery, and wait at least for 90 seconds.
- (c) Connect the horn button assy connectors.
- (d) Connect the negative (-) terminal cable to the battery, and wait at least for 2 seconds.
- (e) Turn the ignition switch to ON, and wait at least for 20 seconds.
- (f) Clear the DTC stored in memory (See page 05-424).
- (g) Turn the ignition switch to LOCK, and wait at least for 20 seconds.
- (h) Turn the ignition switch to ON, and wait at least for 20 seconds.
- (i) Check the DTC (See page 05-424).

OK:

DTC B1181/18 is not output.

HINT:

Codes other than code B1181/18 may be output at this time, but they are not relevant to this check.

NG → **REPLACE HORN BUTTON ASSY**

OK

USE SIMULATION METHOD TO CHECK

4 CHECK INSTRUMENT PANEL WIRE(AIRBAG SENSOR ASSY CENTER - SPIRAL CABLE SUB-ASSY)

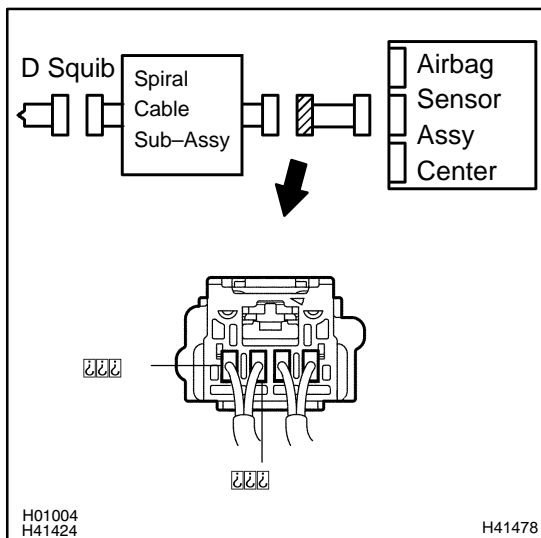

- (a) Disconnect the connector of the instrument panel wire.
- (b) For the connector (on the spiral cable sub-assy side) between the airbag sensor assy center and the spiral cable sub-assy, measure the resistance between D2+ and D2-.

OK:

Resistance: Below 1 Ω

NG → **REPAIR OR REPLACE INSTRUMENT PANEL WIRE(AIRBAG SENSOR ASSY CENTER - SPIRAL CABLE SUB-ASSY)**

OK

5 CHECK SPIRAL CABLE SUB-ASSY

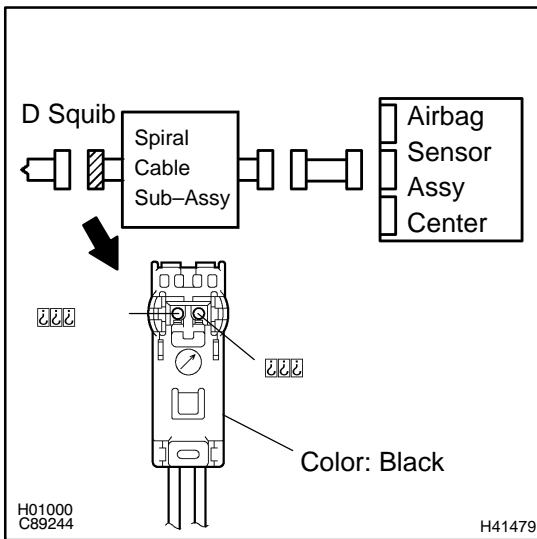

- (a) For the black connector (on the spiral cable sub-assy side) between the horn button assy and the spiral cable sub-assy, measure the resistance between D2+ and D2-.

OK:

Resistance: Below 1 Ω

NG

REPLACE SPIRAL CABLE SUB-ASSY

OK

USE SIMULATION METHOD TO CHECK