

DTC	P0560	SYSTEM VOLTAGE
------------	--------------	-----------------------

MONITOR DESCRIPTION

The battery supplies electricity to the ECM even when the ignition switch is OFF. This electricity allows the ECM store data such as DTC history, freeze frame data, fuel trim values, and other data. If the battery voltage falls below a minimum level, the ECM will conclude that there is a fault in the power supply circuit. At the next engine start, the ECM will turn on the MIL and a DTC will be set.

DTC No.	DTC Detection Condition	Trouble Area
P0560	Open in back-up power source circuit	<ul style="list-style-type: none"> • Open in back-up power source circuit • ECM

MONITOR STRATEGY

Related DTCs	P0560	System voltage malfunction
Required sensors/components	ECM	
Frequency of operation	Continuous	
Duration	3 seconds	
MIL operation	Immediately (*1)	
Sequence of operation	None	

*1: The DTC is set immediately. The MIL will be illuminated after the next engine start.

TYPICAL ENABLING CONDITIONS

Item	Specification	
	Minimum	Maximum
The monitor will run whenever the following DTCs are not present	See "List of Disable a Monitor" (On page 05-25)	
Stand-by RAM	Initialized	

TYPICAL MALFUNCTION THRESHOLDS

Detection Criteria	Threshold
Battery voltage	Less than 3.5 V

WIRING DIAGRAM

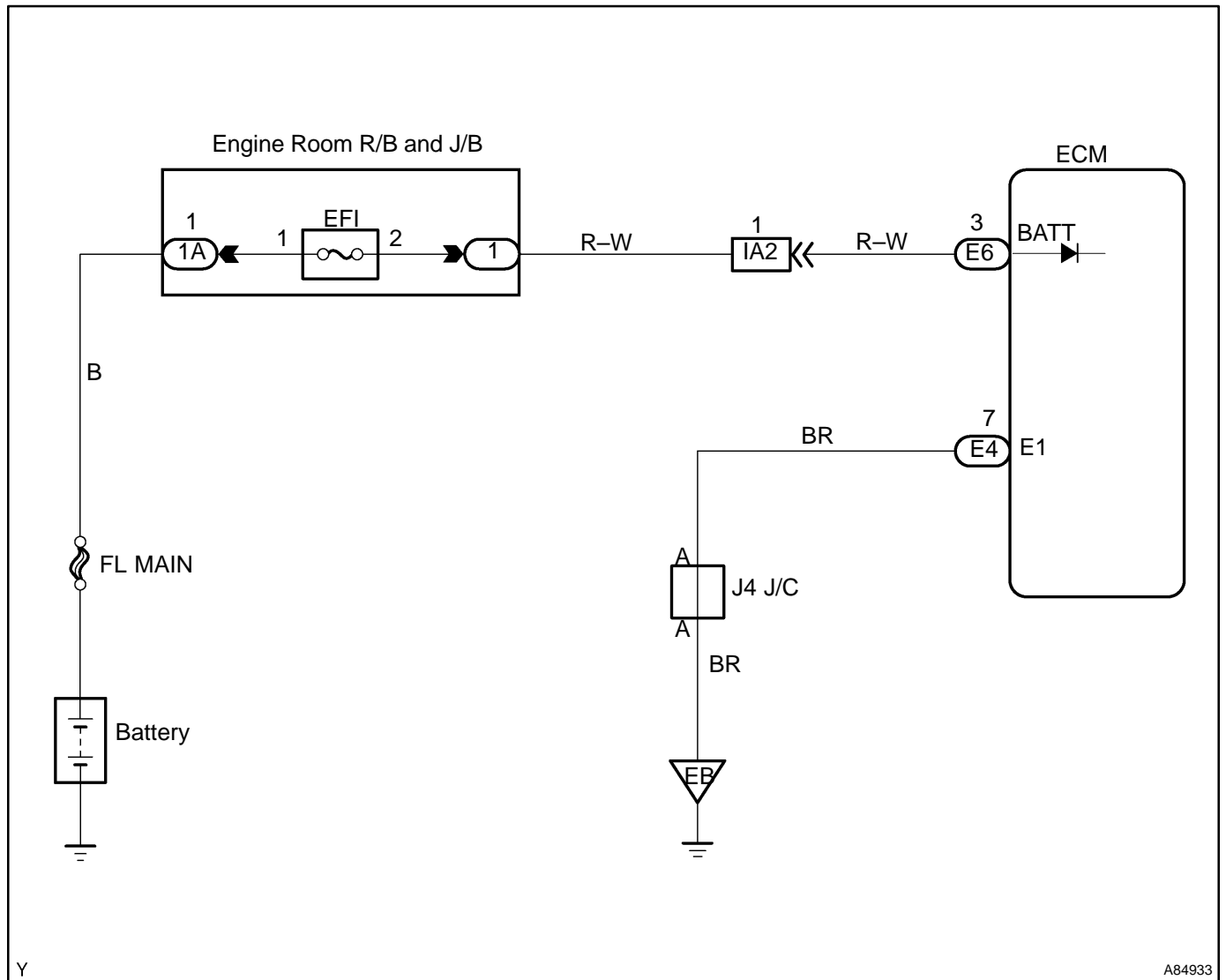

INSPECTION PROCEDURE

HINT:

Read freeze frame data using the hand-held tester or the OBD II scan tool. Freeze frame data records the engine conditions when a malfunction is detected. When troubleshooting, it is useful for determining whether the vehicle was running or stopped, the engine was warmed up or not, the air-fuel ratio was lean or rich, etc. at the time of the malfunction.

1 CHECK FUSE(EFI FUSE)

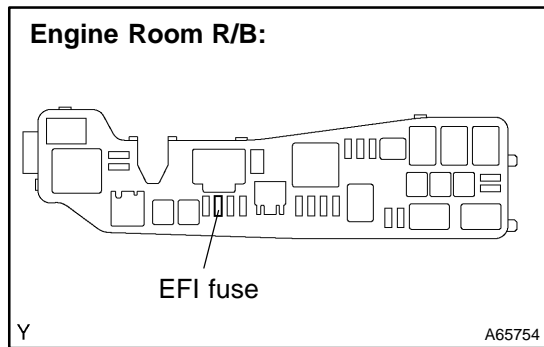

- (a) Remove the EFI fuse from the engine room R/B.
- (b) Check for continuity in the EFI fuse.
Standard: Continuity
- (c) Reinstall the EFI fuse.

NG CHECK FOR SHORT IN ALL HARNESSES AND COMPONENTS CONNECTED FUSE

OK

2 INSPECT ECM(BATT VOLTAGE)

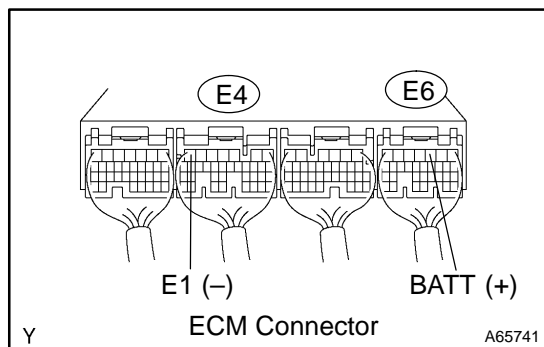

- (a) Measure the voltage between the terminals of the E4 and E6 ECM connectors.

Standard:

Tester Connection	Specified Condition
BATT (E6-3) - E1 (E4-7)	8 to 14 V

OK REPLACE ECM (See page 10-11)

NG

3 CHECK HARNESS AND CONNECTOR(ECM - EFI FUSE, EFI FUSE - BATTERY)

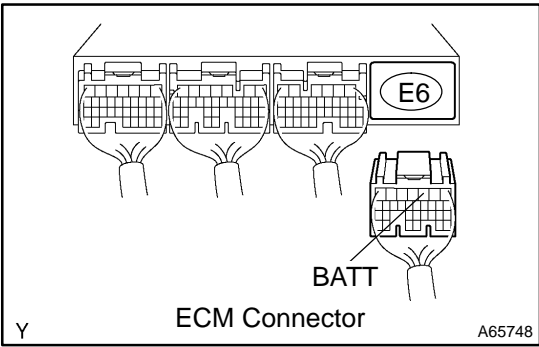

- (a) Check the harness and the connector between the EFI fuse and ECM.
 - (1) Remove the EFI fuse from the engine room R/B.
 - (2) Disconnect the E6 ECM connector.
 - (3) Check the resistance between the wire harness side connectors.

Standard (Check for open):

Tester Connection	Specified Condition
EFI fuse (2) - BATT (E6-3)	Below 1 Ω

Standard (Check for short):

Tester Connection	Specified Condition
EFI fuse (2) or BATT (E6-3) - Body ground	10 kΩ or higher

- (4) Reconnect the ECM connector.
- (5) Reinstall the EFI fuse.

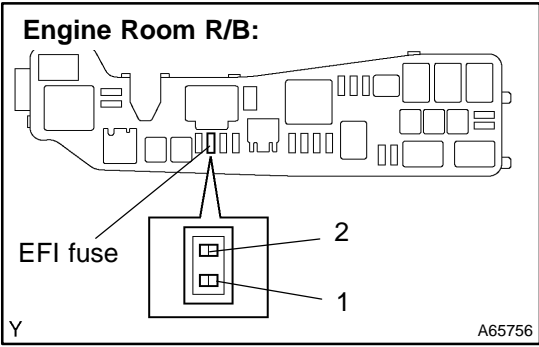

- (b) Check the harness and the connector between the EFI fuse and battery.
 - (1) Remove the EFI fuse from the engine room R/B.
 - (2) Disconnect the battery positive terminal.
 - (3) Check the resistance between the wire harness side connectors.

Standard (Check for open):

Tester Connection	Specified Condition
Battery positive terminal - EFI fuse (1)	Below 1 Ω

Standard (Check for short):

Tester Connection	Specified Condition
Battery positive terminal or EFI fuse (1) - Body ground	10 kΩ or higher

- (4) Reconnect the battery positive terminal.
- (5) Reinstall the EFI fuse.

NG REPAIR OR REPLACE HARNESS OR CONNECTOR

OK

CHECK AND REPLACE ENGINE ROOM RELAY BLOCK ASSY