

DTC	P0442	EVAPORATIVE EMISSION CONTROL SYSTEM LEAK DETECTED (SMALL LEAK)
------------	--------------	---

DTC	P0456	EVAPORATIVE EMISSION CONTROL SYSTEM LEAK DETECTED (VERY SMALL LEAK)
------------	--------------	--

CIRCUIT DESCRIPTION

The vapor pressure sensor and the VSV for the canister closed valve (CCV) are used to detect abnormalities in the evaporative emission control system. The ECM decides whether there is an abnormality in the evaporative emission control system based on the vapor pressure sensor signal.

DTC P0442 or P0456 is recorded by the ECM when evaporative emissions leak from the components within the dotted line in Fig. 1 below, or when the vapor pressure sensor malfunctions.

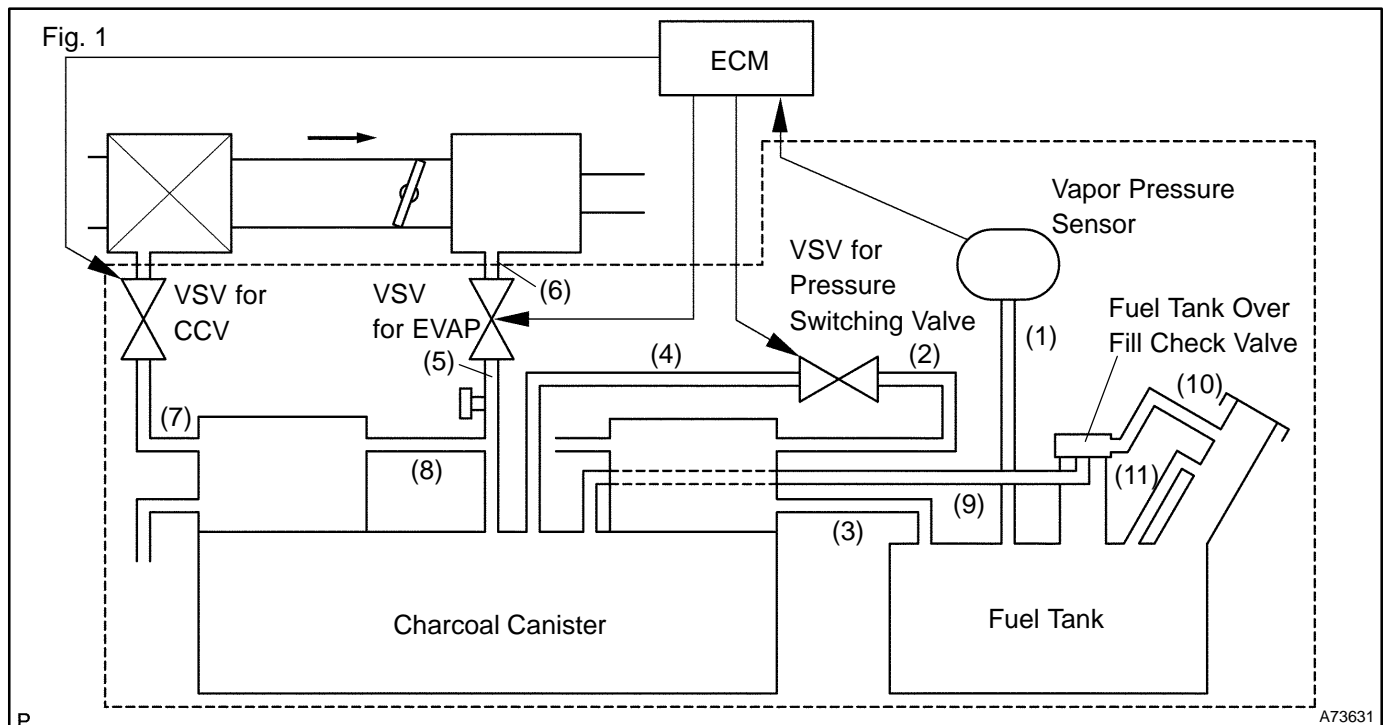

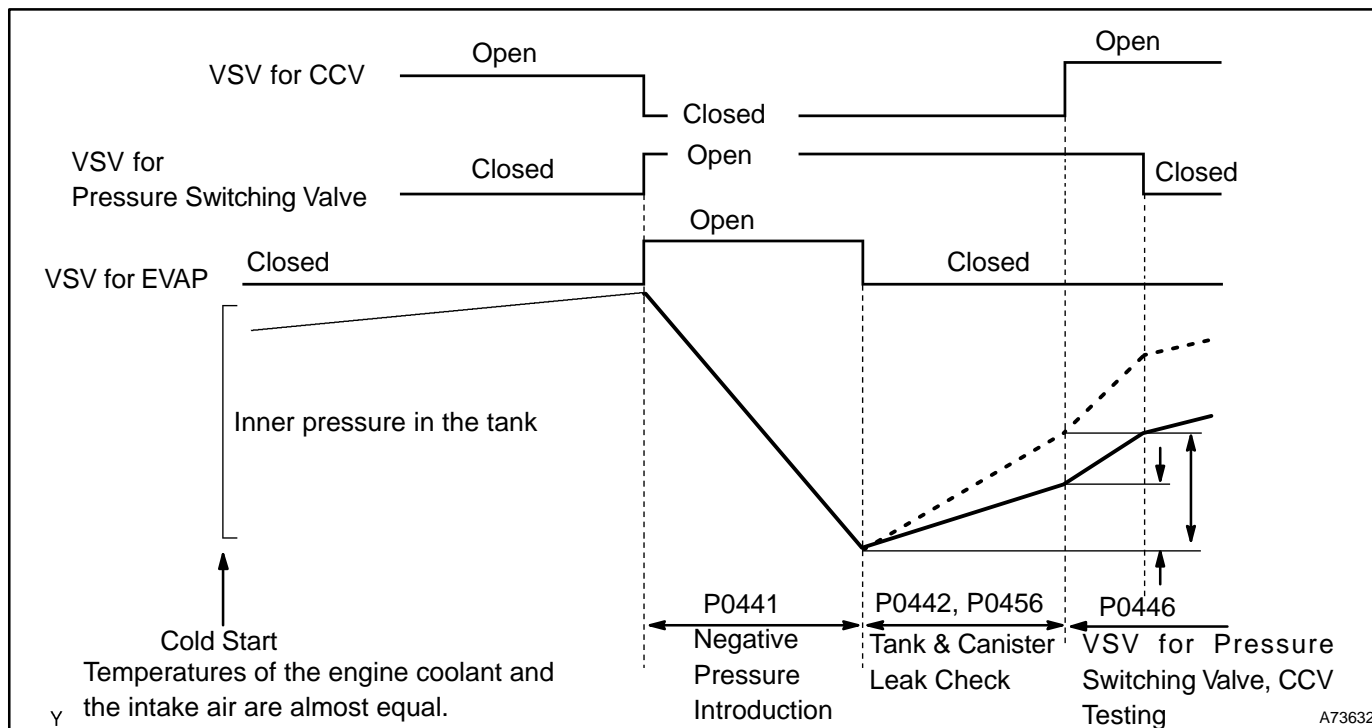

DTC No.	DTC Detection Condition	Trouble Area
P0442	After negative pressure introduction is completed, if the pressure in the EVAP system sharply increases. (small leak) (2 trip detection logic)	<ul style="list-style-type: none"> • Vacuum hose has cracks, holes, or is blocked, damaged or disconnected • Fuel tank cap incorrectly installed • Fuel tank cap has cracks or is damaged • Open or short in vapor pressure sensor circuit • Vapor pressure sensor • Open or short in VSV circuit for EVAP
P0456	If the pressure in the EVAP system slightly increases while the ECM performs a leak check. (very small leak) (2 trip detection logic)	<ul style="list-style-type: none"> • VSV for EVAP • VSV for CCV • VSV for CCV • Fuel tank has cracks, holes, or is damaged • Charcoal canister has cracks, holes, or is damaged • Fuel tank over fill check valve cracks, or is damaged • ECM

HINT:

Typical DTC output of each trouble part.

Trouble part		Typical DTC output (*1)
Small Leak		P0442 and/or P0456 (*2)
Medium Leak (ex: Vacuum hose loose)		P0442
Large Leak (ex: Fuel tank cap loose)		P0441 and P0442 and P0446
VSV for EVAP	Open Malfunction	P0441
	Close Malfunction	P0441 and P0442 and P0446
VSV for CCV	Open Malfunction	P0441 and P0442 and P0446
	Close Malfunction	P0446
VSV for Pressure Switching	Open Malfunction	P0446
	Close Malfunction	P0441 and P0442 and P0446

*1: ECM may output some other DTCs combination.

*2: Refer to DTC P0441 and P0446 on page 05-193

MONITOR DESCRIPTION

The evaporative emission system consists of the vapor pressure sensor, the canister close valve (CCV), the VSV for pressure switching valve and the VSV for EVAP (Purge VSV), those are used to detect malfunction in the system by ECM.

This test will run once per driving cycle when the ECM detects stable vapor pressure in the fuel tank. While the vehicle is being driven on rough or winding roads, the movement of the fuel in the tank will cause unstable fuel tank vapor pressures and the diagnostic test will not executed.

The ECM performs the following steps:

- (a) The CCV is closed. (shutting the system)
- (b) The fuel tank pressure stability is checked. The diagnostic is disabled if the pressure change is more than specified value.
- (c) The VSV for EVAP is opened. This introduces a negative pressure from the intake manifold to the fuel tank.
- (d) The VSV for EVAP is closed and the negative pressure is sealed in the fuel tank.
- (e) The ECM monitors the increase in fuel tank pressure for:
 - (1) Rapid increase in the internal pressure i.e. a large leak: 0.040 or more
 - (2) Pressure rise just above normal

If the ECM detects either of above conditions, it will interpret this as a leak in the EVAP system. The ECM will illuminate the MIL (2-trip detection logic) and set a DTC.

MONITOR STRATEGY

DTCs	P0442	Small leak (0.040 inch or more hole) detected
	P0456	Very small leak (0.020 inch hole) detected
Required sensors/components	Main	Vapor pressure sensor
	Sub	Mass air flow sensor, engine coolant temperature sensor, VSV for EVAP (purge VSV), VSV for CCV
Frequency of operation	Once per drive cycles	
Duration	60 seconds	
MIL operation	2 drive cycles	
Sequence of operation	None	

TYPICAL ENABLING CONDITIONS

Item	Criteria	
	Minimum	Maximum
The monitor will run whenever the following DTCs are not present	See "List of Disable a monitor" (On page 05-25)	
Common pre-conditions for 0.020 and 0.040 inch:		
Altitude	–	2,400 m (7,872 ft.)
Throttle position learning	Completed	
Vapor pressure sensor	No malfunction	
Difference between intake air temperature and engine coolant temperature at engine start.	–7°C (–19.4°F)	11.1°C (52°F)
Vehicle speed condition	A or B	
A. Time after vehicle stopped (less than 6 mph (10 km/h))	90 seconds	–
B. Time after vehicle started (4 mph (7 km/h) or more)	20 seconds	
0.020 inch malfunction detection:		
Engine coolant temperature at engine start	10°C (50°F)	32°C (89.6°F)
Intake air temperature at engine start	10°C (50°F)	32°C (89.6°F)

2004 COROLLA (RM1037U)

DIAGNOSTICS – SFI SYSTEM (April, 2003)

Intake air temperature	10°C (50°F)	–
Fuel level condition in fuel tank during leak check	Fuel slosh is small (must not drive on road with bad conditions)	
Time after engine start	–	50 minutes
Fuel tank pressure condition before leak check (Fuel tank condition before closed negative pressure introduction)	Fuel tank internal pressure change is small before negative pressure introduction. (Reference: If fuel in the tank is high temperature, vapor volume increase and the internal pressure changes also increase)	
Vehicle speed and intake air amount condition before and after negative pressure introduction	Steady speed and not change greatly of intake air amount	
Fuel level	–	90%
0.020 inch leak detection	Not completed	
0.040 inch leak detection	Not detected	
VSV for CCV malfunction, bypass VSV malfunction	Not detected	
Vehicle speed	–	81 mph (130 km/h)
VSV for EVAP (Evap purge VSV) malfunction	Not detected	
0.040 inch malfunction:		
Engine coolant temperature at engine start	10°C (50°F)	35°C (95°F)
Intake air temperature at engine start	10°C (50°F)	35°C (95°F)
Intake air temperature	10°C (50°F)	–
Fuel level condition in fuel tank during leak check	Fuel slosh is small (must not drive on road with bad conditions)	
Time after engine start	–	50min
Fuel tank pressure condition before leak check (Fuel tank condition before closed negative pressure introduction)	Fuel tank internal pressure change is small before negative pressure introduction. (Reference: If fuel in the tank is high temperature, vapor volume increase and the internal pressure changes also increase)	
Vehicle speed and intake air amount condition before and after negative pressure introduction	Steady speed and not change greatly of intake air amount	
Fuel level	–	90%
0.040 inch leak detection	Not completed	
Fuel tank pressure at vacuum introduction completed	–2.4 kPa (–18 mmHg)	–
P0446 VSV check	No executed	

TYPICAL MALFUNCTION THRESHOLDS

Detection Criteria	Threshold
0.020 inch malfunction detection:	
Fuel tank pressure changing value, from –2.0 kPa (–15 mmHg), for 5 seconds	Increase more than 0.067 kPa (0.5 mmHg)
Fuel tank pressure changing value, from –2.7 kPa (–20 mmHg), for 5 seconds	Increase more than 0.067 kPa (0.5 mmHg)
0.040 inch malfunction detection:	
Fuel tank pressure changing value, from –2.0 kPa (–15 mmHg), for 5 seconds	Increase more than 0.24 kPa (1.8 mmHg)
Fuel tank pressure changing value, from –2.7 kPa (–20 mmHg), for 5 seconds	Increase more than 0.24 kPa (1.8 mmHg)

MONITOR RESULT (MODE 06 DATA)

Test ID	Comp ID	Description of Test Data	Description of Test Limit	Unit	Conversion Factor
\$02	\$81	Tank pressure change value during vacuum introduction	Malfunction criteria for VSV for EVAP	mmHg	Multiply by 0.0916
	\$82	Fuel tank pressure change value at switching over the canister close valve or VSV for pressure switching valve.	Malfunction criteria for canister close valve and VSV for pressure switching valve	mmHg	Multiply by 0.0458 minus 2.930
	\$03	Fuel tank pressure change 5 seconds after the end the vacuum introduction cycle	Malfunction criteria for 0.040 leak	mmHg	Multiply by 0.0458
	\$04	Conditions: • VSV for EVAP: Closed • CCV: Closed • VSV for bypass valve: Open	Malfunction criteria for 0.020 leak	mmHg	Multiply by 0.0458

Refer to page [05-27](#) for detailed information on Checking Monitor Status.

INSPECTION PROCEDURE**Hand-held Tester:**

1	CHECK FUEL TANK CAP ASSY(CHECK THAT FUEL TANK CAP IS TOYOTA GENUINE PARTS)
----------	---

NG → **REPLACE TO TOYOTA GENUINE PARTS**

OK

2	CHECK THAT FUEL TANK CAP IS CORRECTLY INSTALLED
----------	--

NG → **CORRECTLY INSTALL FUEL TANK CAP**

OK

3	INSPECT FUEL TANK CAP ASSY (See page 12-1)
----------	---

NG → **REPLACE FUEL TANK CAP ASSY**

OK

4	CHECK FILLER NECK FOR DAMAGE
----------	-------------------------------------

- (a) Remove the fuel tank cap.
- (b) Visually check the fuel inlet pipe for damage.
- (c) Reinstall the fuel tank cap.

NG → **REPLACE FUEL TANK INLET PIPE SUB-ASSY**

OK

5 PERFORM ACTIVE TEST BY HAND-HELD TESTER(CHECK FOR EVAP PURGE FLOW)

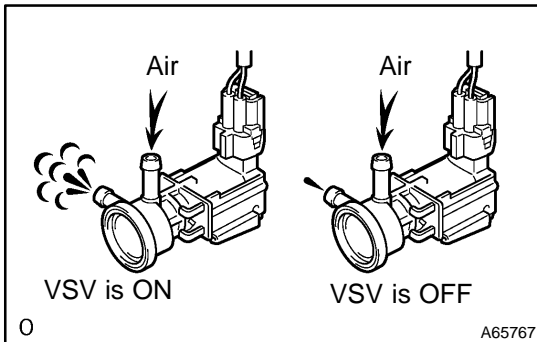

- Select the item "DIAGNOSIS/ENHANCED OBD II/ACTIVE TEST" mode on the hand-held tester.
- Disconnect the vacuum hose of the VSV for EVAP from the charcoal canister.
- Start the engine.
- Select the item "EVAP VSV (ALON)/ALL" in the ACTIVE TEST and operate EVAP VSV (Press the right or left button).
- When the VSV for the EVAP is operated by the hand-held tester, check whether the disconnected hose applies suction to your finger.

Result:

VSV is ON: Disconnected hose sucks.

VSV is OFF: Disconnected hose does not suck.

- Reconnect the vacuum hose.

OK

Go to step 9

NG

6 CHECK VACUUM HOSES(INTAKE MANIFOLD - VSV FOR EVAP, VSV FOR EVAP - CHARCOAL CANISTER)

- Check that the vacuum hose is connected correctly.
- Check the vacuum hose for looseness and disconnection.
- Check the vacuum hose for cracks, hole, damage and blockage.

NG

REPAIR OR REPLACE VACUUM HOSE

OK

7 INSPECT VSV FOR EVAP(OPERATION) (See page 12-1)

NG

REPLACE VSV FOR EVAP

OK

8 CHECK HARNESS AND CONNECTOR(EFI RELAY - VSV FOR EVAP, VSV FOR EVAP - ECM)

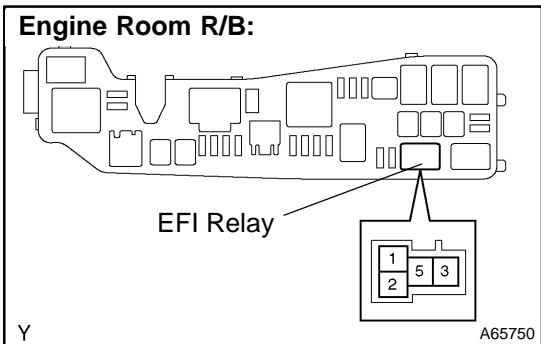
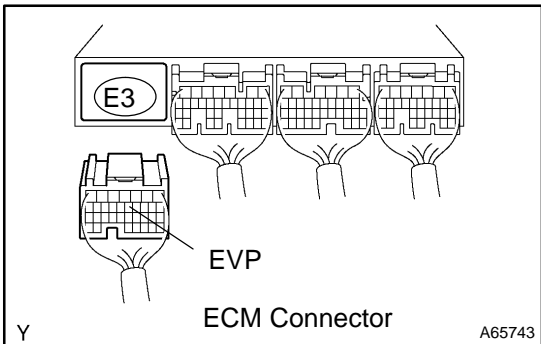
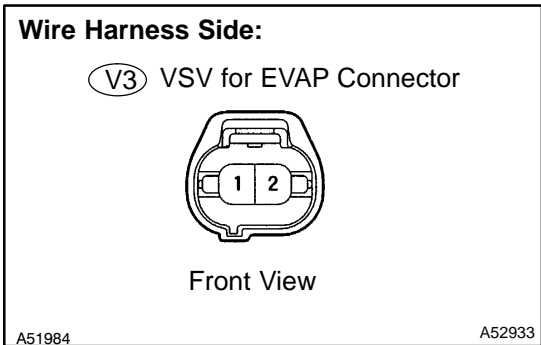

- (a) Check the harness and the connector between the VSV for EVAP and ECM.
- (1) Disconnect the V3 VSV for EVAP connector.
 - (2) Disconnect the E3 ECM connector.
 - (3) Check the resistance between the wire harness side connectors.

Standard (Check for open):

Tester Connection	Specified Condition
VSV for EVAP (V3-1) - EVP (E3-12)	Below 1 Ω

Standard (Check for short):

Tester Connection	Specified Condition
VSV for EVAP (V3-1) or EVP (E3-12) - Body ground	10 kΩ or higher

- (4) Reconnect the VSV for EVAP connector.
 - (5) Reconnect the ECM connector.
- (b) Check the harness and the connector between the VSV for EVAP and EFI relay.
- (1) Disconnect the V3 VSV for EVAP connector.
 - (2) Remove the EFI relay from the engine room R/B.
 - (3) Check the resistance between the wire harness side connectors.

Standard (Check for open):

Tester Connection	Specified Condition
VSV for EVAP (V3-2) - EFI relay (3)	Below 1 Ω

Standard (Check for short):

Tester Connection	Specified Condition
VSV for EVAP (V3-2) or EFI relay (3) - Body ground	10 kΩ or higher

- (4) Reconnect the VSV for EVAP connector.
- (5) Reinstall the EFI relay.

NG REPAIR OR REPLACE HARNESS OR CONNECTOR

OK

REPLACE ECM (See page 10-11)

9 PERFORM ACTIVE TEST BY HAND-HELD TESTER(VSV FOR CCV)

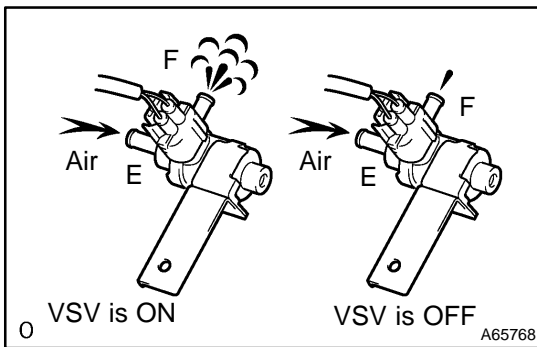

- Disconnect the vacuum hose of the VSV for CCV from the charcoal canister.
- Start the engine.
- Select the item "DIAGNOSIS/ENHANCED OBD II/ACTIVE TEST" mode on the hand-held tester.
- Select the item "CAN CTRL VSV/ALL" in the ACTIVE TEST and operate CAN CTRL VSV (Press the right or left button).
- Check the VSV operation when it is operated by the hand-held tester.

Result:

VSV is ON: Air from port E flows out through port F.

VSV is OFF: Air does not flow from port E to port F.

OK → Go to step 13

NG

10 CHECK VACUUM HOSES(VSV FOR CCV - CHARCOAL CANISTER)

- Check that the vacuum hose is connected correctly.
- Check the vacuum hose for looseness and disconnection.
- Check the vacuum hose for cracks, hole damage and blockage.

NG → REPAIR OR REPLACE VACUUM HOSES

OK

11 INSPECT VSV FOR CCV(OPERATION) (See page 12-6)

NG → REPLACE VSV FOR CCV

OK

12 CHECK HARNESS AND CONNECTOR(EFI RELAY - VSV FOR CCV, VSV FOR CCV - ECM)

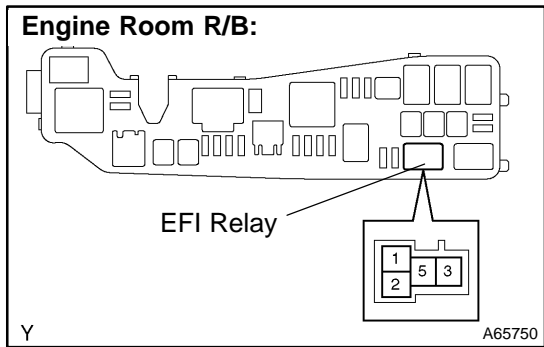
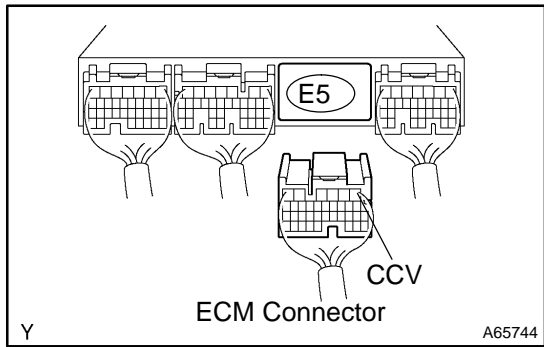
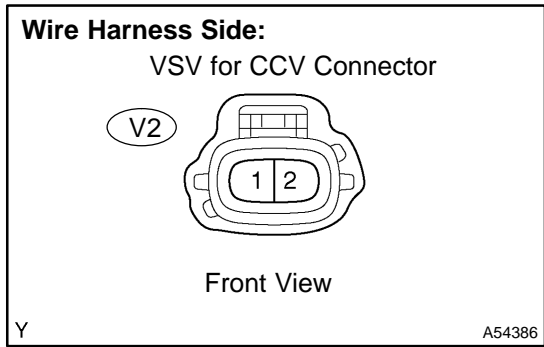

- (a) Check the harness and connector between the VSV for CCV and ECM.
- (1) Disconnect the V2 VSV for CCV connector.
 - (2) Disconnect the E5 ECM connector.
 - (3) Check the resistance between the wire harness side connectors.

Standard (Check for open):

Tester Connection	Specified Condition
VSV for CCV (V2-1) - CCV (E5-1)	Below 1 Ω

Tester Connection	Specified Condition
VSV for CCV (V2-1) or CCV (E5-1) - Body ground	10 kΩ or higher

- (4) Reconnect the VSV for CCV connector.
- (5) Reconnect the ECM connector.

- (b) Check the harness and the connector between the VSV for CCV and EFI relay.

- (1) Disconnect the V2 VSV for CCV connector.
- (2) Remove the EFI relay from the engine room R/B.
- (3) Check the resistance between the wire harness side connectors.

Standard (Check for open):

Tester Connection	Specified Condition
VSV for CCV (V2-2) - EFI relay (3)	Below 1 Ω

Standard (Check for short):

Tester Connection	Specified Condition
VSV for CCV (V2-2) or EFI relay (3) - Body ground	10 kΩ or higher

- (4) Reconnect the VSV for CCV connector.
- (5) Reinstall the EFI relay.

NG REPAIR OR REPLACE HARNESS OR CONNECTOR

OK

REPLACE ECM (See page 10-11)

13	PERFORM ACTIVE TEST BY HAND-HELD TESTER(VSV FOR PRESSURE SWITCHING VALVE)
-----------	--

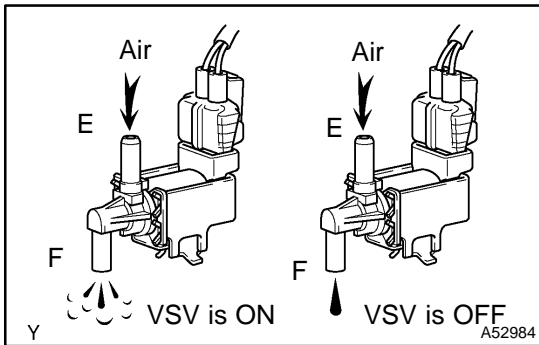

- (a) Select the item "DIAGNOSIS/ENHANCED OBD II/ACTIVE TEST" mode on the hand-held tester.
- (b) Select the item "TANK BYPASS VSV/ALL" in the ACTIVE TEST and operate TANK BYPASS VSV (Press the right or left button).
- (c) Check the VSV operation when it is operated by the hand-held tester.

Result:**VSV is ON:** Air from port E flows out through port F.**VSV is OFF:** Air does not flow from port E to port F.

OK

Go to step 16

NG

14	INSPECT VSV FOR PRESSURE SWITCHING VALVE(OPERATION)
-----------	--

NG

REPLACE VSV FOR PRESSURE SWITCHING VALVE

OK

15 CHECK HARNESS AND CONNECTOR(EFI RELAY - VSV FOR PRESSURE SWITCHING VALVE, VSV FOR PRESSURE SWITCHING VALVE - ECM)

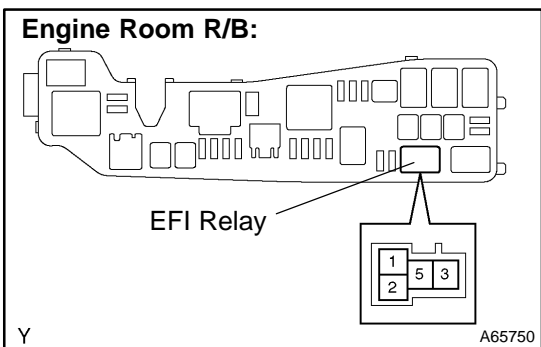
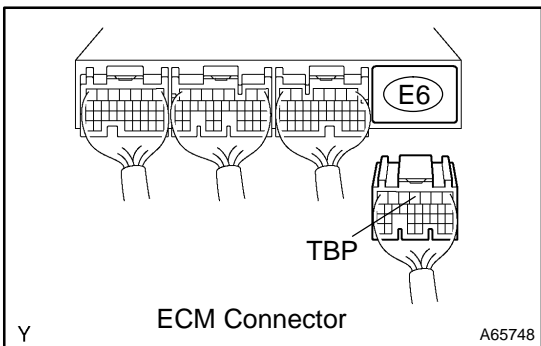
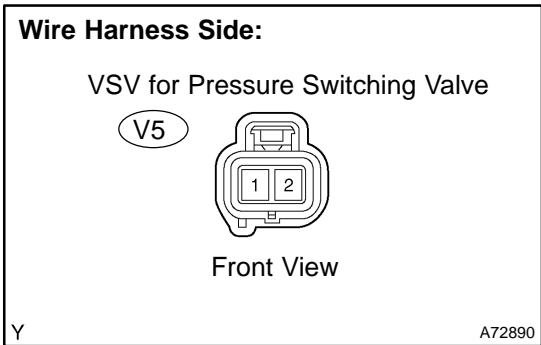

- (a) Check the harness and the connector between the VSV for pressure switching valve and the ECM.
- (1) Disconnect the V5 VSV for pressure switching valve connector.
 - (2) Disconnect the E6 ECM connector.
 - (3) Check the resistance between the wire harness side connectors.

Standard (Check for open):

Tester Connection	Specified Condition
VSV for pressure switching valve (V5-1) - TBP (E6-4)	Below 1 Ω

Standard (Check for short):

Tester Connection	Specified Condition
VSV for pressure switching valve (V5-1) or TBP (E6-4) - Body ground	10 kΩ or higher

- (4) Reconnect the VSV for pressure switching valve connector.
 - (5) Reconnect the ECM connector.
- (b) Check the harness and the connector between the VSV for pressure switching valve and EFI relay.

- (1) Disconnect the V5 VSV for pressure switching valve connector.
- (2) Remove the EFI relay from the engine room R/B.
- (3) Check the resistance between the wire harness side connectors.

Standard (Check for open):

Tester Connection	Specified Condition
VSV for pressure switching valve (V5-2) - EFI relay (3)	Below 1 Ω

Standard (Check for short):

Tester Connection	Specified Condition
VSV for pressure switching valve (V5-2) or EFI relay (3) - Body ground	10 kΩ or higher

- (4) Reconnect the VSV for pressure switching valve connector.
- (5) Reinstall the EFI relay.

NG **REPAIR OR REPLACE HARNESS OR CONNECTOR**

OK

REPLACE ECM (See page 10-11)

16 CHECK FOR EVAPORATIVE EMISSIONS LEAK(NEAR FUEL TANK)

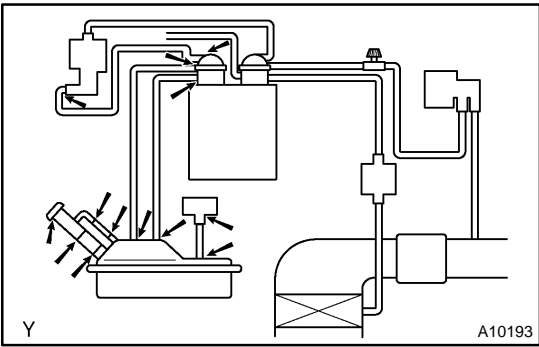

- (a) Check whether hoses close to the fuel tank have been modified, and check if there are signs of any accident near the fuel tank.
 - (1) Check the following parts for cracks, deformation or loose connection:
 - Fuel tank
 - Fuel tank filler pipe
 - Hoses and tubes around fuel tank

NG REPAIR OR REPLACE EVAPORATIVE EMISSIONS LEAK PART

OK

17 CHECK VACUUM HOSES(VAPOR PRESSURE SENSOR – FUEL TANK, CHARCOAL CANISTER – VSV FOR PRESSURE SWITCHING VALVE)

- (a) Check that the vacuum hose is connected correctly.
- (b) Check the vacuum hose for looseness and disconnection.
- (c) Check the vacuum hose for cracks, hole and damage.

NG REPAIR OR REPLACE VACUUM HOSE

OK

18 CHECK HOSE AND TUBE(FUEL TANK – CHARCOAL CANISTER)

- (a) Check the connection between the fuel tank and fuel EVAP pipe, the fuel EVAP pipe and under floor fuel tube, the under floor fuel tube and charcoal canister.
- (b) Check the hose and the tube for cracks, hole and damage.

NG REPAIR OR REPLACE HOSE AND TUBE

OK

19 INSPECT ECM(VC VOLTAGE)

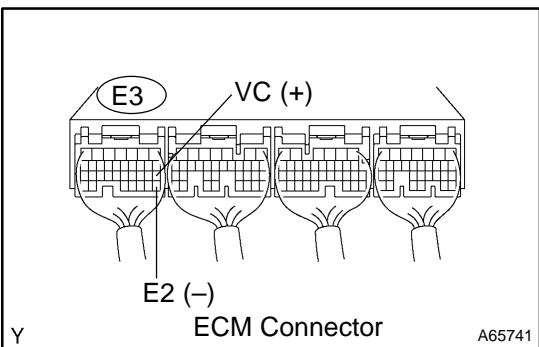

- (a) Turn the ignition switch ON.
- (b) Measure the voltage between the terminals of the E3 ECM connector.

Standard:

Tester Connection	Specified Condition
VC (E3-18) – E2 (E3-28)	4.5 to 5.5 V

NG REPLACE ECM (See page 10-11)

OK

20 INSPECT ECM(PTNK VOLTAGE)

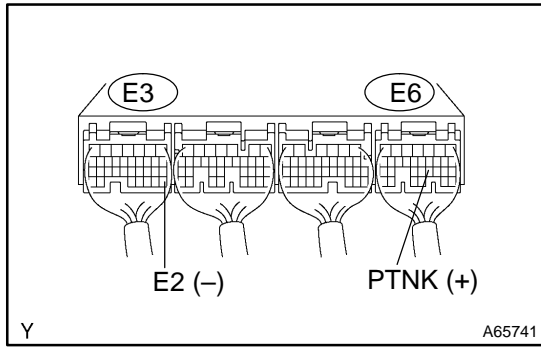

- (a) Turn the ignition switch ON.
- (b) Measure the voltage between terminals of the E3 and E6 ECM connectors.
 - (1) Disconnect the vacuum hose from the vapor pressure sensor.

Standard (1):

Tester Connection	Specified Condition
PTNK (E6-21) - E2 (E3-28)	2.9 to 3.7 V

NOTICE:

The vacuum applied to the vapor pressure sensor must be less than 66.7 kPa (500 mmHg, 19.7 in.Hg).

- (2) Using the MITYVAC (Hand-held Vacuum Pump), apply a vacuum of 4.0 kPa (30 mmHg, 1.18 in.Hg) to the vapor pressure sensor.

Standard (2):

Tester Connection	Specified Condition
PTNK (E6-21) - E2 (E3-28)	0.5 V or less

- (3) Reconnect the vacuum hose.

OK → Go to step 22

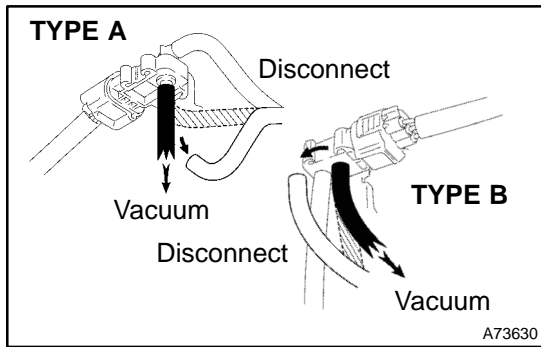

NG

21 CHECK HARNESS AND CONNECTOR(VAPOR PRESSURE SENSOR - ECM)

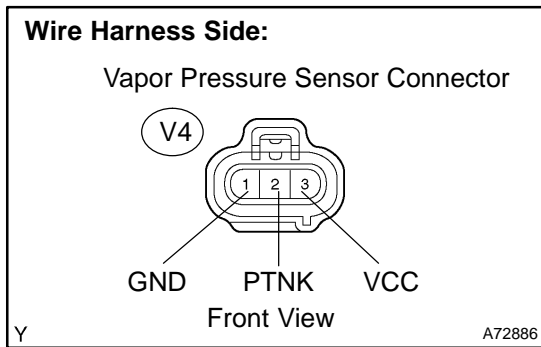

- (a) Disconnect the V4 vapor pressure sensor connector.
- (b) Disconnect the E3 and E6 ECM connectors.
- (c) Check the resistance between the wire harness side connectors.

Standard (Check for open):

Tester Connection	Specified Condition
PTNK (V4-2) - PTNK (E6-21)	Below 1 Ω
GND (V4-1) - E2 (E3-28)	
VCC (V4-3) - VC (E3-18)	

Standard (Check for short):

Tester Connection	Specified Condition
PTNK (V4-2) or PTNK (E6-21) - Body ground	10 kΩ or higher
VCC (V4-3) or VC (E3-18) - Body ground	

- (d) Reconnect the vapor pressure sensor connector.
- (e) Reconnect the ECM connectors.

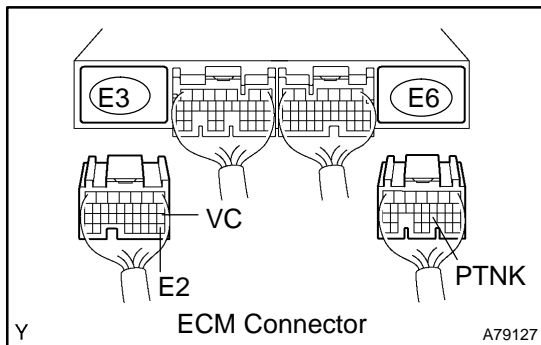

NG → REPAIR OR REPLACE HARNESS OR CONNECTOR

OK

REPLACE ECM (See page 10-11)

22 INSPECT FUEL TANK INLET VALVE ASSY

NG → REPLACE FUEL TANK INLET VALVE ASSY

OK

23 INSPECT FUEL TANK ASSY

NG → REPLACE FUEL TANK ASSY

OK

24 INSPECT CHARCOAL CANISTER ASSY(CRACKS, HOLE AND DAMAGE)

NG → REPAIR OR REPLACE CHARCOAL CANISTER ASSY

OK

REPLACE ECM (See page 10-11)

OBDII scan tool (excluding Hand-held Tester):

1 CHECK FUEL TANK CAP ASSY(CHECK THAT FUEL TANK CAP IS TOYOTA GENUINE PARTS)

NG → REPLACE TO GENUINE PARTS

OK

2 CHECK THAT FUEL TANK CAP IS CORRECTLY INSTALLED

NG → CORRECTLY INSTALL FUEL TANK CAP

OK

3 INSPECT FUEL TANK CAP ASSY (See page 12-1)

NG → REPLACE FUEL TANK CAP ASSY

OK

4 CHECK FILLER NECK FOR DAMAGE

- (a) Remove the fuel tank cap.
 (b) Visually check the fuel inlet pipe for damage.

NG

REPLACE FUEL TANK INLET PIPE SUB-ASSY

OK

5 CHECK FOR EVAPORATIVE EMISSIONS LEAK(NEAR FUEL TANK OR CHARCOAL CANISTER)

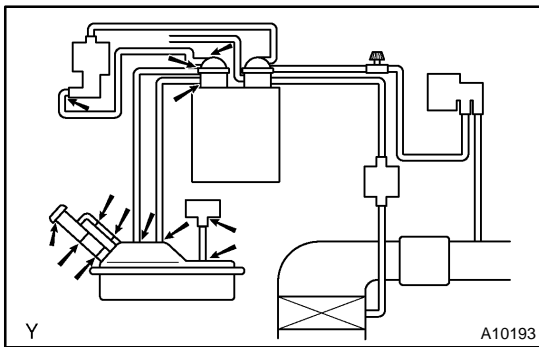

- (a) Check whether hoses close to the fuel tank have been modified, and check if there are signs of any accident near the fuel tank or the charcoal canister.
- (1) Check the following parts for cracks, deformation or loose connection:
- Fuel tank
 - Charcoal canister
 - Fuel tank filler pipe
 - Hoses and tubes around fuel tank and charcoal canister

NG

REPAIR OR REPLACE EVAPORATIVE EMISSIONS LEAK PART

OK

6 CHECK VACUUM HOSES(VAPOR PRESSURE SENSOR – FUEL TANK, CHARCOAL CANISTER – VSV FOR PRESSURE SWITCHING VALVE)

- (a) Check that the vacuum hose is connected correctly.
 (b) Check the vacuum hose for looseness and disconnection.
 (c) Check the vacuum hose for cracks, hole and damage.

NG

REPAIR OR REPLACE VACUUM HOSE

OK

7 CHECK HOSE AND TUBE(FUEL TANK – CHARCOAL CANISTER)

- (a) Check the connection between the fuel tank and fuel EVAP pipe, the fuel EVAP pipe and under floor fuel tube, the under floor fuel tube and charcoal canister.
 (b) Check the hose and the tube for cracks, hole and damage.

NG

REPAIR OR REPLACE HOSE AND TUBE

OK

8 CHECK VACUUM HOSES((5), (6), (7), (8) AND (9) IN FIG. 1 IN CIRCUIT DESCRIPTION)

- (a) Check that the vacuum hose is connected correctly.
- (b) Check the vacuum hose for looseness and disconnection.
- (c) Check the vacuum hose for cracks, hole and damage.

NG REPAIR OR REPLACE VACUUM HOSES

OK

9 CHECK EACH VSV CONNECTOR FOR LOOSENESS AND DISCONNECTION(VSV FOR EVAP, VSV FOR CCV, VSV FOR PRESSURE SWITCHING VALVE)

NG REPAIR OR CONNECT VSV AND SENSOR CONNECTOR

OK

10 INSPECT CHARCOAL CANISTER ASSY(CRACKS, HOLE AND DAMAGE)

NG CHECK AND REPLACE CHARCOAL CANISTER ASSY

OK

11 INSPECT ECM(VC VOLTAGE)

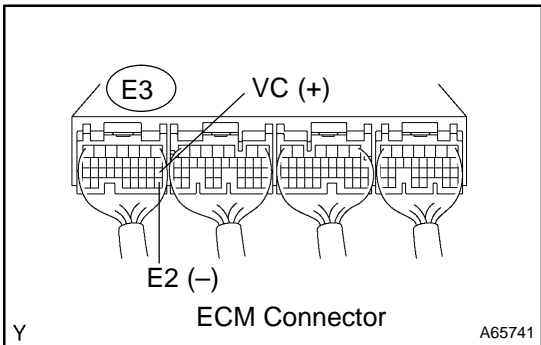

- (a) Turn the ignition switch ON.
- (b) Measure voltage between the terminals of the E3 ECM connector.

Standard:

Tester Connection	Specified Condition
VC (E3-18) - E2 (E3-28)	4.5 to 5.5 V

NG REPLACE ECM (See page 10-11)

OK

12 INSPECT ECM(PTNK VOLTAGE)

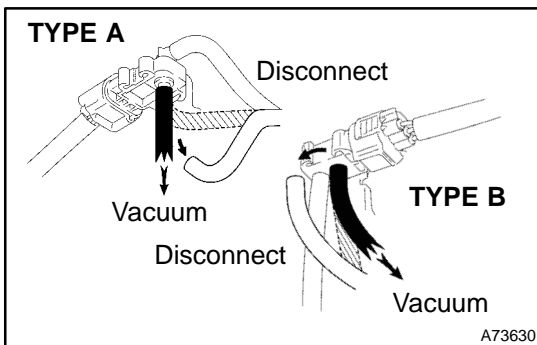
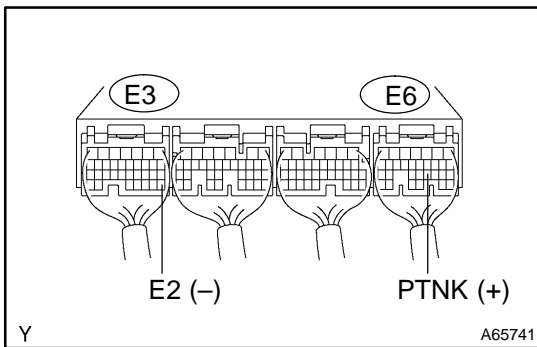

- (a) Turn the ignition switch ON.
- (b) Measure the voltage between terminals of the E3 and E6 ECM connectors.
 - (1) Disconnect the vacuum hose from the vapor pressure sensor.

Standard (1):

Tester Connection	Specified Condition
PTNK (E6-21) - E2 (E3-28)	2.9 to 3.7 V

NOTICE:

The vacuum applied to the vapor pressure sensor must be less than 66.7 kPa (500 mmHg, 19.7 in.Hg).

- (2) Using the MITYVAC (Hand-held Vacuum Pump), apply a vacuum of 4.0 kPa (30 mmHg, 1.18 in.Hg) to the vapor pressure sensor.

Standard (2):

Tester Connection	Specified Condition
PTNK (E6-21) - E2 (E3-28)	0.5 V or less

- (3) Reconnect the vacuum hose from the vapor pressure sensor.

OK

Go to step 14

NG

13 CHECK HARNESS AND CONNECTOR(VAPOR PRESSURE SENSOR - ECM)

Wire Harness Side:

Vapor Pressure Sensor Connector

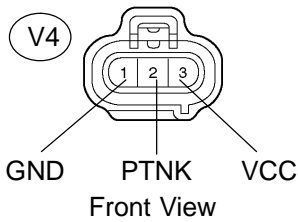

Y A72886

- (a) Disconnect the V4 vapor pressure sensor connector.
- (b) Disconnect the E3 and E6 ECM connectors.
- (c) Check the resistance between the wire harness side connectors.

Standard (Check for open):

Tester Connection	Specified Condition
PTNK (V4-2) - PTNK (E6-21)	Below 1 Ω
GND (V4-1) - E2 (E3-28)	
VCC (V4-3) - VC (E3-18)	

Standard (Check for short):

Tester Connection	Specified Condition
PTNK (V4-2) or PTNK (E6-21) - Body ground	10 kΩ or higher
VCC (V4-3) or VC (E3-18) - Body ground	

- (d) Reconnect the vapor pressure sensor connector.
- (e) Reconnect the ECM connectors.

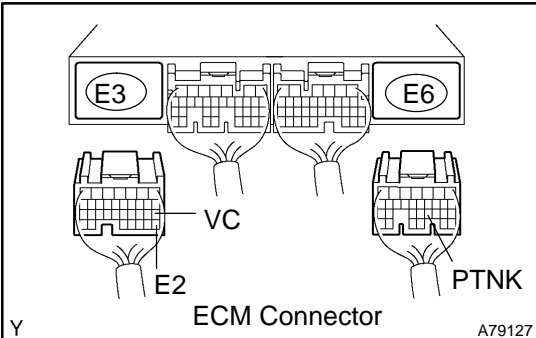

Y A79127

NG REPAIR OR REPLACE HARNESS OR CONNECTOR

OK

REPLACE ECM (See page 10-11)

14 INSPECT VSV FOR EVAP(FUNCTION)

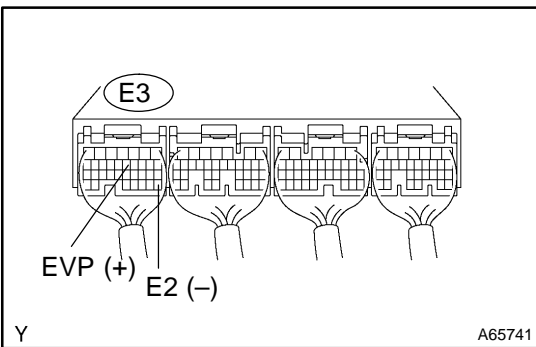

Y A65741

- (a) Turn the ignition switch ON.
- (b) Check the VSV function.
 - (1) Connect between terminals EVP and E2 of the ECM connector (VSV ON).

VSV is ON:

Air from port E flows out through port F

- (2) Disconnect between terminals EVP and E2 of the ECM connector (VSV OFF).

VSV is OFF:

Air does not flow port E to port F

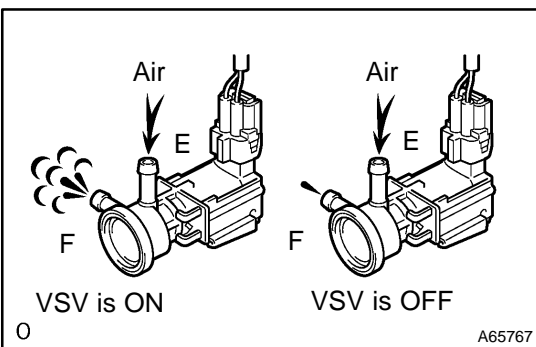

O A65767

OK Go to step 17

NG

15 INSPECT VSV FOR EVAP(OPERATION) (See page 12-6)

NG REPLACE VSV FOR EVAP

OK

16 CHECK HARNESS AND CONNECTOR(EFI RELAY - VSV FOR EVAP, VSV FOR EVAP - ECM)

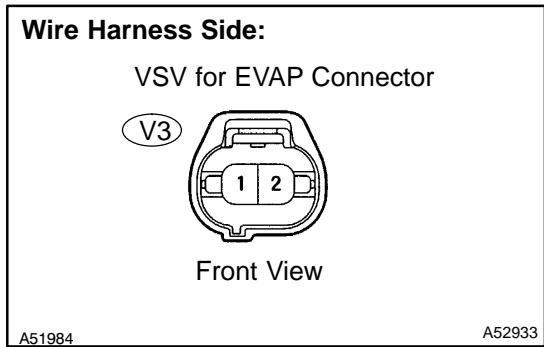

- (a) Check the harness and connector between the VSV for EVAP and ECM.
- (1) Disconnect the V3 VSV for EVAP connector.
 - (2) Disconnect the E3 ECM connector.
 - (3) Check the resistance between the wire harness side connectors.

Standard (Check for open):

Tester Connection	Specified Condition
VSV for EVAP (V3-1) - EVP (E3-12)	Below 1 Ω

Standard (Check for short):

Tester Connection	Specified Condition
VSV for EVAP (V3-1) or EVP (E3-12) - Body ground	10 kΩ or higher

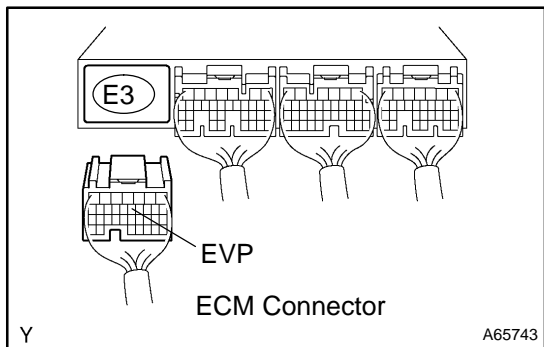

- (4) Reconnect the VSV for EVAP connector.
 - (5) Reconnect the ECM connector.
- (b) Check the harness and connector between the VSV for EVAP and EFI relay.
- (1) Disconnect the V3 VSV for EVAP connector.
 - (2) Remove the EFI relay from the engine room R/B.
 - (3) Check the resistance between the wire harness side connectors.

Standard (Check for open):

Tester Connection	Specified Condition
VSV for EVAP (V3-2) - EFI relay (3)	Below 1 Ω

Standard (Check for short):

Tester Connection	Specified Condition
VSV for EVAP (V3-2) or EFI relay (3) - Body ground	10 kΩ or higher

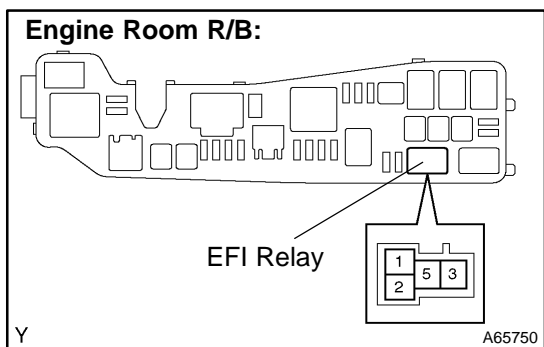

- (4) Reconnect the VSV for EVAP connector.
- (5) Reinstall the EFI relay.

NG REPAIR OR REPLACE HARNESS OR CONNECTOR

OK

REPLACE ECM (See page 10-11)

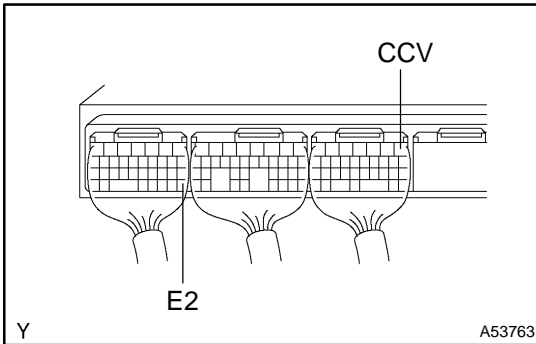
17 INSPECT VSV FOR CCV(FUNCTION)

- (a) Turn the ignition switch ON.
 (b) Check the VSV function.
 (1) Connect between terminals CCV and E2 of the ECM connector (VSV ON).

VSV is ON:

Air from port E flows out through port F

- (2) Disconnect between terminals CCV and E2 of the ECM connector (VSV OFF).

VSV is OFF:

Air does not flow from port E to port F

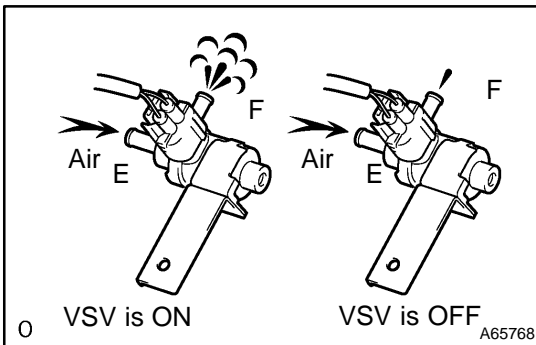

OK

Go to step 20

NG

18 INSPECT VSV FOR CCV(OPERATION) (See page 12-6)

NG

REPLACE VSV FOR CCV

OK

19 CHECK HARNESS AND CONNECTOR(EFI RELAY - VSV FOR CCV, VSV FOR CCV - ECM)

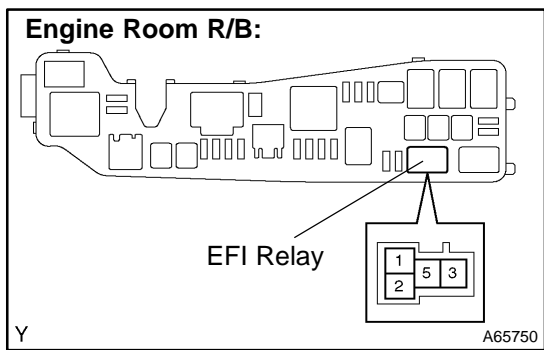
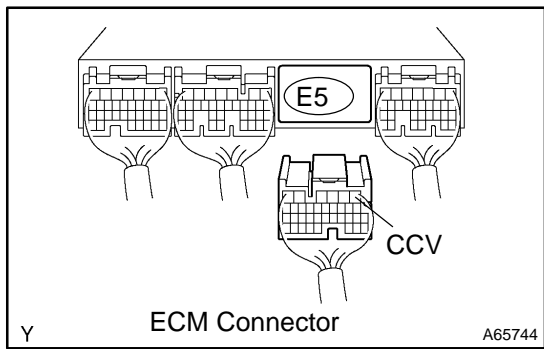
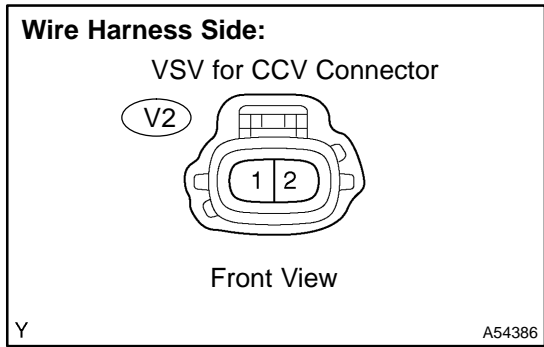

- (a) Check the harness and the connector between the VSV for CCV and ECM.
- (1) Disconnect the V2 VSV for CCV connector.
 - (2) Disconnect the E5 ECM connector.
 - (3) Check the resistance between the wire harness side connectors.

Standard (Check for open):

Tester Connection	Specified Condition
VSV for CCV (V2-1) - CCV (E5-1)	Below 1 Ω

Standard (Check for short):

Tester Connection	Specified Condition
VSV for CCV (V2-1) or CCV (E5-1) - Body ground	10 kΩ or higher

- (4) Reconnect the VSV for CCV connector.
 - (5) Reconnect the ECM connector.
- (b) Check the harness and the connector between the VSV for CCV and EFI relay.
- (1) Disconnect the V2 VSV for CCV connector.
 - (2) Remove the EFI relay from the engine room R/B.
 - (3) Check the resistance between the wire harness side connectors.

Standard (Check for open):

Tester Connection	Specified Condition
VSV for CCV (V2-2) - EFI relay (3)	Below 1 Ω

Standard (Check for short):

Tester Connection	Specified Condition
VSV for CCV (V2-2) or EFI relay (3) - Body ground	10 kΩ or higher

- (4) Reconnect the VSV for CCV connector.
- (5) Reinstall the EFI relay.

NG REPAIR OR REPLACE HARNESS OR CONNECTOR

OK

REPLACE ECM (See page 10-11)

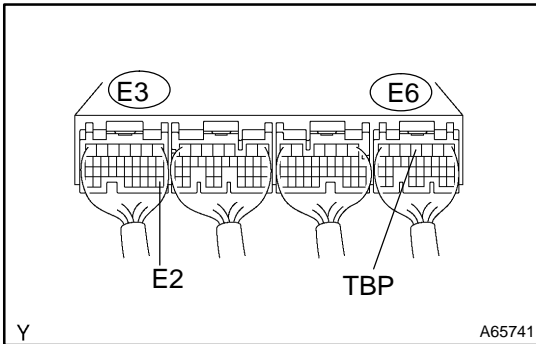
20 INSPECT VSV FOR PRESSURE SWITCHING VALVE(FUNCTION)

- (a) Turn the ignition switch ON.
- (b) Check the VSV function.
 - (1) Connect between terminals TBP and E2 of the ECM connector (VSV ON).

VSV is ON: Air from port E flows out through port F

- (2) Disconnect between terminals TBP and E2 of the ECM connector (VSV OFF).

VSV is OFF: Air does not flow from port E to port F

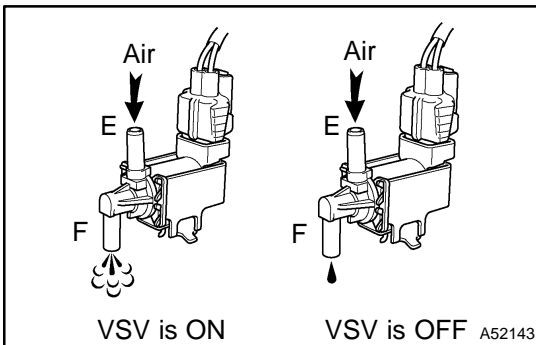

OK Go to step 23

NG

21 INSPECT VSV FOR PRESSURE SWITCHING VALVE(OPERATION)
 (See page 12-6)

NG REPLACE VSV FOR PRESSURE SWITCHING VALVE

OK

22 CHECK HARNESS AND CONNECTOR(EFI RELAY – VSV FOR PRESSURE SWITCHING VALVE, VSV FOR PRESSURE SWITCHING VALVE – ECM)

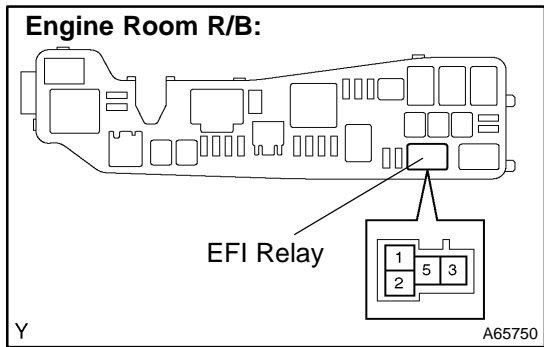
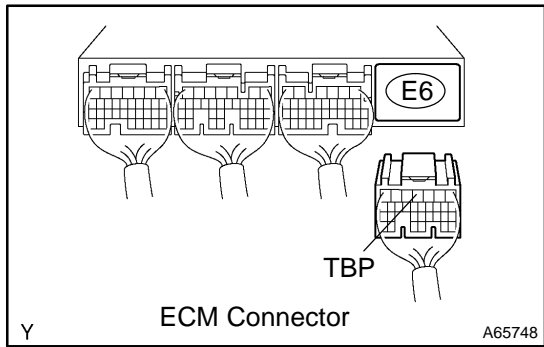
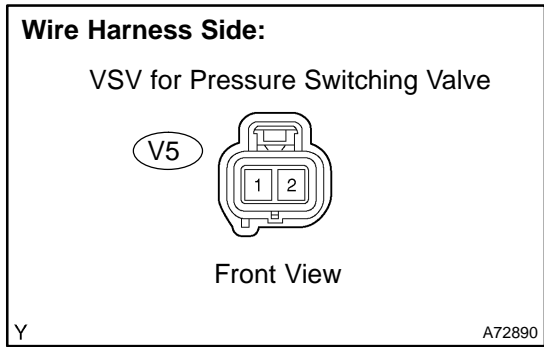

- (a) Check the harness and the connector between the VSV for pressure switching valve and ECM.
- (1) Disconnect the V5 VSV for pressure switching valve connector.
 - (2) Disconnect the E6 ECM connector.
 - (3) Check the resistance between the wire harness side connectors.

Standard (Check for open):

Tester Connection	Specified Condition
VSV for pressure switching valve (V5-1) – TBP (E6-4)	Below 1 Ω

Standard (Check for short):

Tester Connection	Specified Condition
VSV for pressure switching valve (V5-1) or TBP (E6-4) – Body ground	10 kΩ or higher

- (4) Reconnect the VSV for pressure switching valve connector.
- (5) Reconnect the ECM connector.

- (b) Check the harness and the connector between the VSV for pressure switching valve and EFI relay.

- (1) Disconnect the V5 VSV for pressure switching valve connector.
- (2) Remove the EFI relay from the engine room R/B.
- (3) Check the resistance between the wire harness side connectors.

Standard (Check for open):

Tester Connection	Specified Condition
VSV for pressure switching valve (V5-2) – EFI relay (3)	Below 1 Ω

Standard (Check for short):

Tester Connection	Specified Condition
VSV for pressure switching valve (V5-2) or EFI relay (3) – Body ground	10 kΩ or higher

- (4) Reconnect the VSV for pressure switching valve connector.
- (5) Reinstall the EFI relay from.

NG → **REPAIR OR REPLACE HARNESS OR CONNECTOR**

OK

REPLACE ECM (See page 10-11)

23	INSPECT FUEL TANK INLET VALVE ASSY
----	------------------------------------

NG	REPLACE FUEL TANK INLET VALVE ASSY
----	------------------------------------

OK

24	INSPECT FUEL TANK ASSY
----	------------------------

NG	REPLACE FUEL TANK ASSY
----	------------------------

OK

IT IS LIKELY THAT VEHICLE USER DID NOT PROPERLY CLOSE FUEL TANK CAP
