

DTC	P0973	SHIFT SOLENOID "A" CONTROL CIRCUIT LOW (SHIFT SOLENOID VALVE S1)
------------	--------------	---

DTC	P0974	SHIFT SOLENOID "A" CONTROL CIRCUIT HIGH (SHIFT SOLENOID VALVE S1)
------------	--------------	--

CIRCUIT DESCRIPTION

Shifting from 1st to O/D is performed in combination with ON and OFF of the shift solenoid valve S1 and S2 controlled by ECM. If an open or short circuit occurs in either of the solenoid valves, the ECM controls the remaining normal solenoid valve to allow the vehicle to be operated smoothly (Fail safe function).

Fail safe function:

If either of the solenoid valve circuits develops an open or short, the ECM turns the other solenoid valve ON and OFF to shift to the gear positions shown in the table below. If both solenoids malfunction, hydraulic control cannot be performed electronically and must be done manually.

Manual shifting as shown in the above table must be done (In the case of a short circuit, the ECM stops sending current to the short circuited solenoid).

Position	NORMAL			S1 SOLENOID VALVE MALFUNCTIONING			S2 SOLENOID VALVE MALFUNCTIONING			BOTH SOLENOID MALFUNCTIONING
	Solenoid valve		Gear	Solenoid valve		Gear	Solenoid valve		Gear	Gear when shift selector is manually operated
	S1	S2		S1	S2		S1	S2		
D	ON	OFF	1st	X	ON	3rd	ON	X	1st	O/D
	ON	ON	2nd	X	ON	3rd	OFF	X	O/D	O/D
	OFF	ON	3rd	X	ON	3rd	OFF	X	O/D	O/D
	OFF	OFF	O/D	X	OFF	O/D	OFF	X	O/D	O/D
2	ON	OFF	1st	X	ON	3rd	ON	X	1st	O/D
	ON	ON	2nd	X	ON	3rd	OFF	X	3rd	O/D
	OFF	ON	3rd	X	ON	3rd	OFF	X	3rd	O/D
L	ON	OFF	1st	X	OFF	1st	ON	X	1st	1st
	ON	ON	2nd	X	ON	2nd	ON	X	1st	1st

X: Malfunctions

DTC No.	DTC Detection Condition	Trouble Area
P0973	ECM detects short in solenoid valve S1 circuit 4 times when solenoid valve S1 is operated (1-detection logic)	<ul style="list-style-type: none"> • Short in shift solenoid valve S1 circuit • Shift solenoid valve S1 • ECM
P0974	ECM detects open in solenoid valve S1 circuit 4 times when solenoid valve S1 is not operated (1-detection logic)	<ul style="list-style-type: none"> • Open in shift solenoid valve S1 circuit • Shift solenoid valve S1 • ECM

MONITOR DESCRIPTION

The ECM commands gearshift by turning the shift solenoid valves "ON/OFF". When there is an open or short circuit in any shift solenoid valve circuit, the ECM detects the problem and the MIL comes on. Illuminating the MIL, the ECM performs the fail-safe and turns the other shift solenoid valves in good condition "ON/OFF" (In case of an open or short circuit, the ECM stops sending current to the circuit.).

MONITOR STRATEGY

Related DTCs	P0973	Shift solenoid "A"/Range check (Low resistance)
	P0974	Shift solenoid "A"/Range check (High resistance)
Required sensors/Components	Shift solenoid valve S1	
Frequency of operation	Continuous	
Duration	2 times or more	
MIL operation	Immediate	
Sequence of operation	None	

TYPICAL ENABLING CONDITION

Item	Specification	
	Minimum	Maximum
The monitor will run whenever the following DTCs are not present.	See page 05-369	
Range check (Low resistance)		
Solenoid	ON	
Time after solenoid OFF to ON	More than 0.008 sec.	–
Range check (High resistance)		
Solenoid	OFF	
Time after solenoid ON to OFF	More than 0.008 sec.	–

TYPICAL MALFUNCTION THRESHOLDS

Detection criteria	Threshold
Range check (Low resistance)	
Number of solenoid ON/OFF change with intelligent power MOS diagnosis signal failure (Fail at solenoid resistance $\leq 8 \Omega$)	4 times (0.064 sec.)
Range check (High resistance)	
Number of solenoid ON/OFF change with intelligent power MOS diagnosis signal failure (Fail at solenoid resistance $\geq 100 \text{ k}\Omega$)	4 times (0.064 sec.)

COMPONENT OPERATING RANGE

Parameter	Standard value
Shift solenoid valve S1 resistance	11 to 15 Ω at 20°C (68°F)

WIRING DIAGRAM

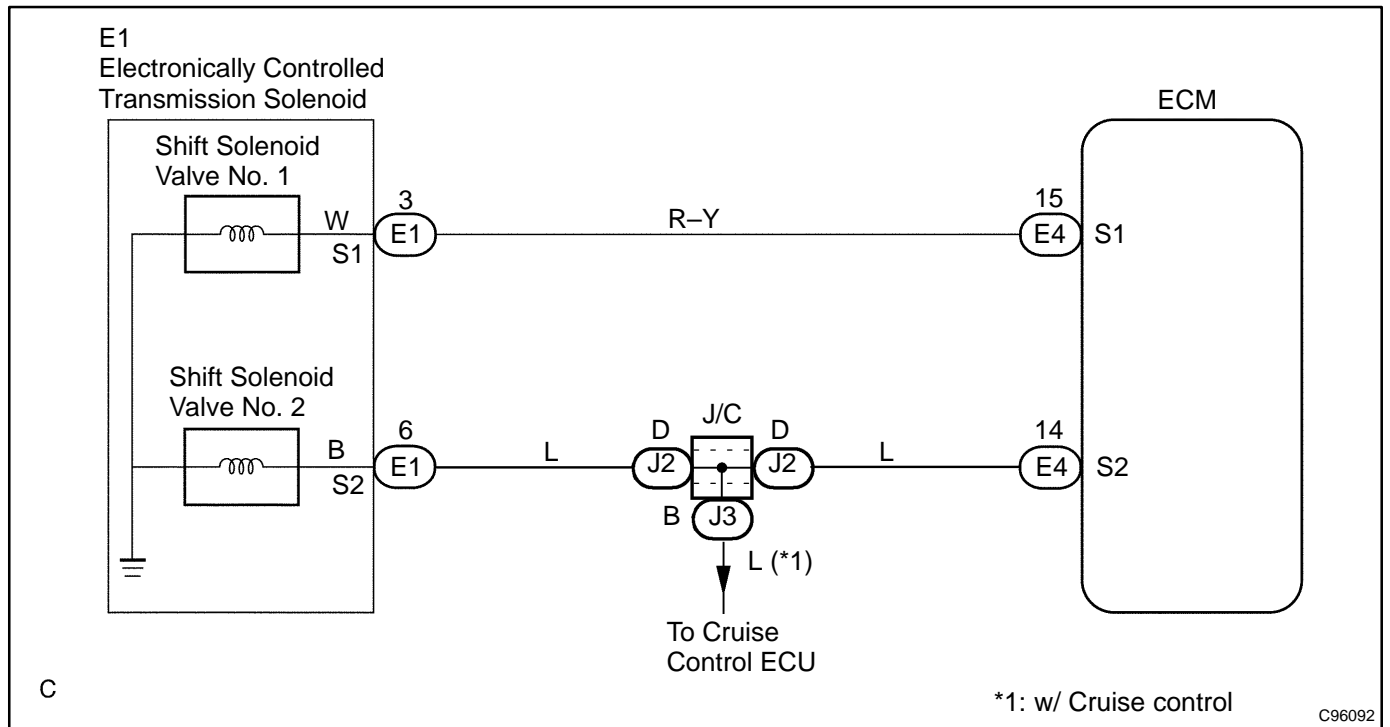

INSPECTION PROCEDURE

1 INSPECT TRANSMISSION WIRE(S1)

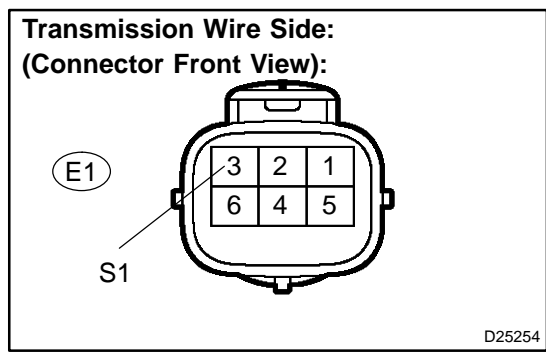

- (a) Disconnect the transmission wire connector from the transaxle.
- (b) Measure the resistance according to the value(s) in the table below.

Standard:

Tester Connection	Specified Condition 20 °C (68 °F)
3 – Body ground	11 to 15 Ω

NG → Go to step 3

OK

2 CHECK HARNESS AND CONNECTOR(TRANSMISSION WIRE – ECM)

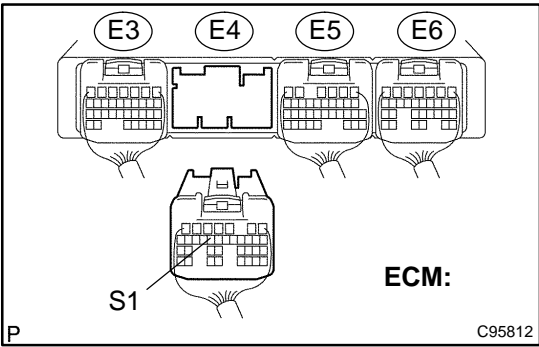

- (a) Connect the transmission connector to the transaxle.
- (b) Disconnect the connector from the ECM.
- (c) Measure the resistance according to the value(s) in the table below.

Standard:

Tester Connection	Specified Condition 20 °C (68 °F)
E4 – 15 (S1) – Body ground	11 to 15 Ω

NG → **REPAIR OR REPLACE HARNESS OR CONNECTOR (See page 01-30)**

OK

REPLACE ECM (See page 10-11)

3 INSPECT SHIFT SOLENOID VALVE(S1)

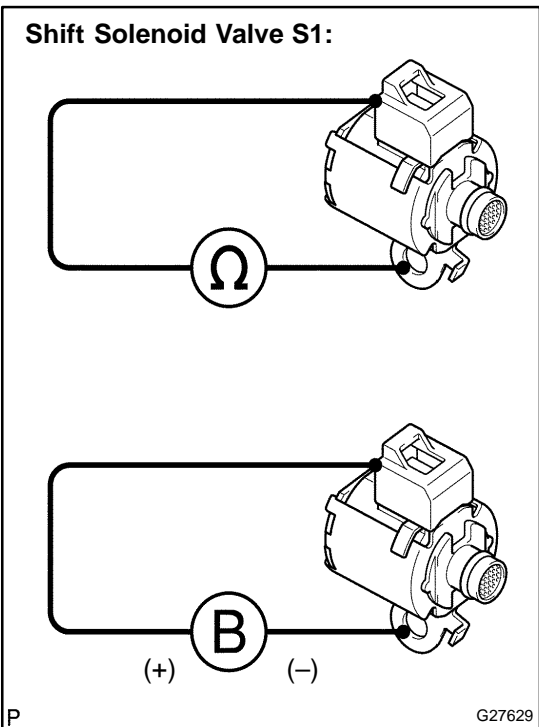

- (a) Remove the shift solenoid valve S1.
- (b) Measure the resistance according to the value(s) in the table below.

Standard:

Tester Connection	Specified Condition 20 °C (68 °F)
Solenoid Connector (S1) – Solenoid Body (S1)	11 to 15 Ω

- (c) Connect the positive (+) battery lead to the solenoid connector terminal, and the negative (-) battery lead to the solenoid body for checking the solenoid valve operation.

Standard:

The solenoid makes an operating noise.

NG → **REPLACE SHIFT SOLENOID VALVE(S1)**

OK

REPAIR OR REPLACE TRANSMISSION WIRE (See page 40-27)