

TURNING ON LIGHT SWITCH DOES NOT LIGHT UP NIGHT TIME ILLUMINATION OF RADIO RECEIVER

WIRING DIAGRAM

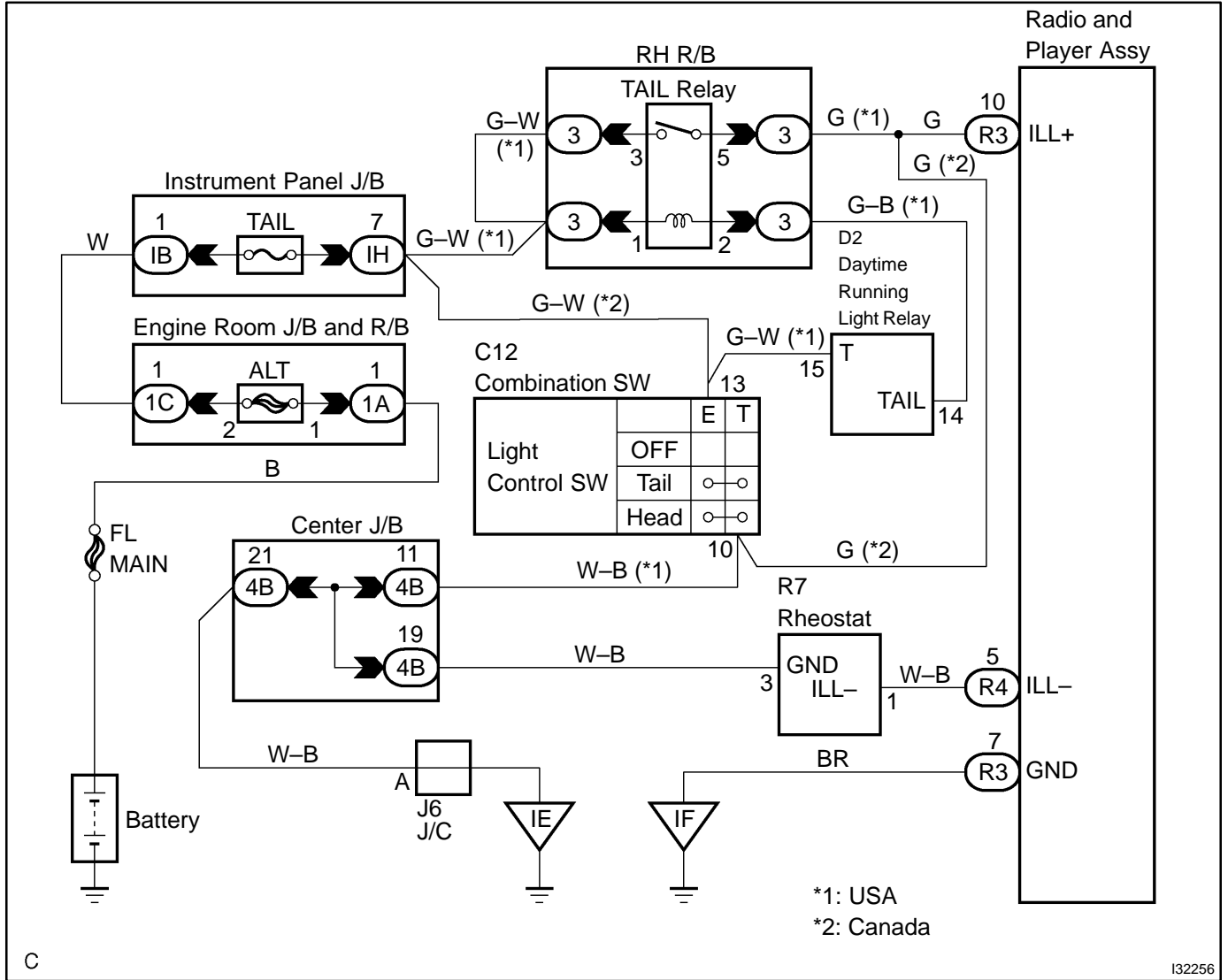

INSPECTION PROCEDURE

1 INSPECT RADIO RECEIVER ASSY(ILL+, ILL-)

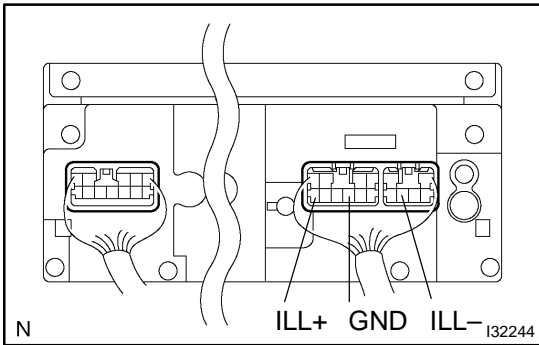

(a) Check that the voltage between terminals at each condition, as shown in the chart.

Standard:

Tester connection	Condition	Specified condition
ILL+ - GND	Light control switch TAIL or HEAD	10 - 14 V
ILL- - GND	Light control switch HI or FLASH	10 - 14 V

OK CHECK AND REPLACE RADIO RECEIVER ASSY

NG

REPAIR OR REPLACE HARNESS OR CONNECTOR