PAPER MAGIC

**BEING A COLLECTION OF
Entertaining and Amusing Models, Toys, Puzzles, Conjuring
Tricks, etc.,
in which Paper is the only or principal material required.**

by
WILL BLYTH

Author of "Handkerchief Magic," "Match Stick Magic," and "More Paper Magic."

Member of the Executive Council of the "Magic Circle."

With Introductory Note by NEVIL MASKELYNE

ILLUSTRATED BY 147 DIAGRAMS

1923

DEDICATED WITH FRATERNAL REGARDS TO MY FELLOW MEMBERS of
THE "MAGIC CIRCLE," AMONG WHOM I HAVE SPENT SO MANY HAPPY
HOURS

©2002 Cigam FTP

[Table of Contents](#)

Pdf version by TARKO The GREAT



Paper Magic

Will Blyth

[Next](#) | [Previous](#)

[Introductory Note](#)

[Foreword](#)

PART I

[Army Forage Cap](#)

[Ash Tray](#)

[Breakfast Cruet](#)

[Chinese Junk](#)

[Christmas Star](#)

[Dart](#)

[Drill Sword](#)

[Easter Cross](#)

[Flap Purse](#)

[Flapper](#)

[The Flying Aeroplane](#)

[Kettle](#)

[Lifeboat](#)

[Mechanical Conjuring Trick](#)

[Parachute](#)

[Pin Tray](#)

[Puff Ball](#)

[Puzzle Box](#)

[Sailing Boat](#)

[Saucepan](#)

[Smoke Ring Box](#)

[Soldier's Hat](#)

[Twin Rowing Boat](#)

[Windmill](#)

[Working Bellows](#)

PART II

[Introduction](#)

[Ball of Mahomet](#)

[Bewildering Tissues](#)

[Episode of Mere Man, An](#)

[Four Boy Scouts](#)

[Gains of the Great War](#)

[Magic Purse](#)

[Mind Divination](#)

[Moths of Japan](#)

[Orchard Story, An](#)

[Paper Bag Cookery](#)

[Paper Tearing Act](#)

[Ribbons of India](#)

[Separating the Services](#)

[Spirit Calculator](#)

[Thought Reading](#)

[Two Blacksmiths](#)

[Two Little Dicky Birds](#)

[L'envoi](#)

[Next](#) | [Previous](#)

Paper Magic

Will Blyth

[Next](#) | [Previous](#) | [Contents](#)

Introductory Note

Mr. Will Blyth's book on "Paper Magic" is a most interesting work upon the subject; containing, as it does, so much matter not to be found elsewhere.

It not only includes the elementary paper-folding manipulations familiar to most of us in our early days, but also much that should prove entertaining during the leisure moments of our later years.

NEVIL MASKELYNE.

St. George's Hall,

Langham Place,

London, W. 1.

29 th June, 1920.

[Next](#) | [Previous](#) | [Contents](#)

Paper Magic

Will Blyth

[Next](#) | [Previous](#) | [Contents](#)

Foreword

Paper is one of the easiest materials to obtain, and to those who are interested in finding a useful means of utilizing some of the household accumulations, the present volume will undoubtedly appeal. It will be noticed that the book has been divided into two parts, and the first portion, dealing with Toys, Models, Puzzles, etc. made entirely from paper, will be found to provide a fascinating and at the same time, inexpensive form of amusement for the younger members of the home circle. The second section deals with some effective conjuring tricks, in which paper is the only or principal article employed, and some important remarks on this branch of paper magic will be found on these pages.

Every item in Part I. has been very fully described, and all the workings illustrated with progressive diagrams, in order to render the work of construction as easy as possible. I am hopeful that there will be no disappointed readers of this book, and that the youngest reader will find little difficulty in making any of the items given by following the instructions and comparing each fold with the illustration, all of which have been designed from the actual paper models. The first part will also be found useful to adults for the amusement of children at a private party, and with a little pre-practice in folding the children could be interested and entertained, by showing them how to make up some of the models. It will be found that this innovation will be gladly welcomed by the little visitors and in most cases prove a strong rival to the older forms of amusement usually arranged. I have found the study of paper folding and paper magic most interesting and entertaining, and have for years past made a note of every paper fold and paper magical effect that came to my notice--these have now been written up, illustrated, and published in the present form in the hope that they may prove a source of amusement and entertainment to a wide circle of readers, both young and old, during the long winter evenings.

WILL BLYTH.

Magic Circle Club-room,
Anderton's Hotel,
Fleet Street, E.C.
May, 1920.

[Next](#) | [Previous](#) | [Contents](#)

Paper Magic

Will Blyth

[Next](#) | [Previous](#) | [Contents](#)

Part I Paper Folding

Soldier's Hat

This is a most elementary paper folding item, being well known to most boys and girls, and has been utilized for the "uniform" of many youthful bands of warriors. The correct method of folding is as follows:

Take a sheet of newspaper and fold it in half as Fig. I. Turn down the top corners A, A, of Fig. I along the dotted lines, to the centre B, and fold up the bottom strip C, about two inches. Turn the paper over and repeat the bottom fold on the other side, thus forming Fig. 2.

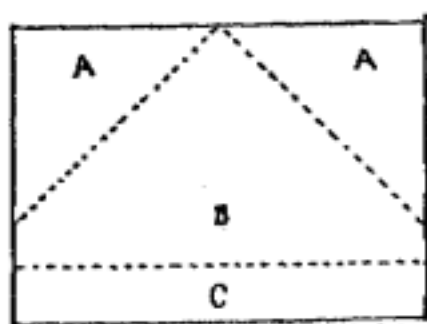

FIG. 1

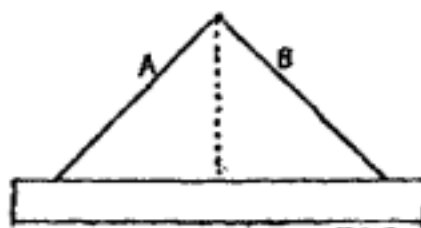

FIG. 2

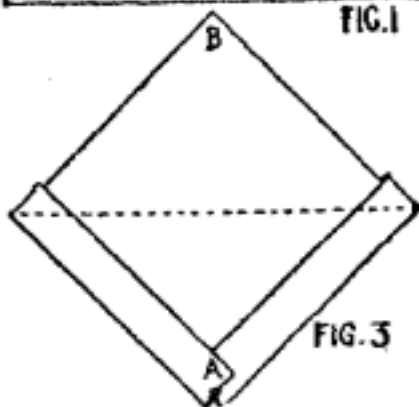

FIG. 3



FIG. 4

Now place both thumbs inside the bottom opening, till the paper opens, and refold it so that the dotted line of Fig. 2 is on the outside, the edges A, B, forming the centre line on either side; this folding will give Fig. 3.

Finally fold Fig. 3 along the dotted line, bringing A, to B, and the cap is complete as Fig. 4.

[Next](#) | [Previous](#) | [Contents](#)

Paper Magic

Will Blyth

[Next](#) | [Previous](#) | [Contents](#)

Drill Sword

Having made the hat and provided "uniform" for the regiment, it is now necessary to provide arms for the fray. For "playing at soldiers" boys usually like to have swords, and a simple one can easily be made from paper by tearing a strip about six inches wide off a double sheet of newspaper and rolling it up fairly loosely, similarly to Fig. 5. The end can be secured with a piece of gummed paper. This must be pulled out from the centre to the fullest extent of the roll, when it will be found that a good substitute for a sword has been made, as Fig. 6.

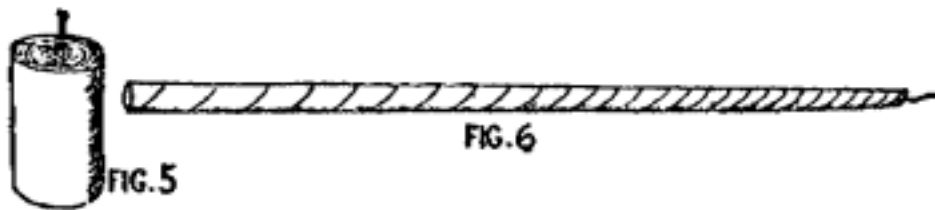

Although not adapted for protective or aggressive purposes, it will at least serve its purpose as an article of drill.

[Next](#) | [Previous](#) | [Contents](#)

Paper Magic

Will Blyth

[Next](#) | [Previous](#) | [Contents](#)

Sailing Boat

The paper sailing boat is a very easy fold, being a development of the Soldier's hat (Fig. 4). Place both thumbs inside the hat, and with the fingers pressing outside pull gently, and refold the hat so that A, and B, of Fig. 4 form the centre on either side, G, being on the outside, making Fig. 7.

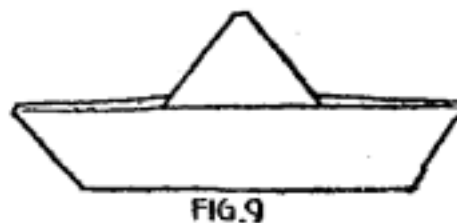
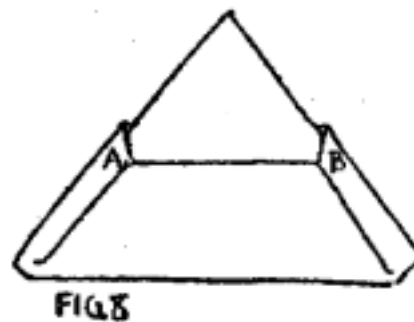
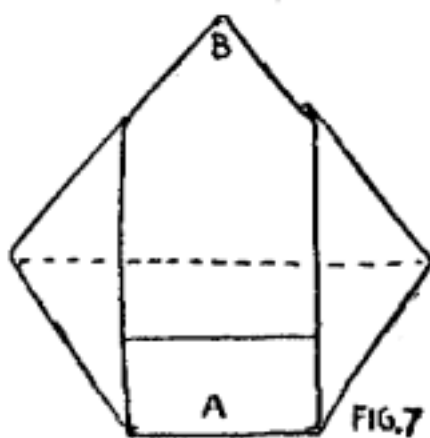

Now fold Fig. 7 along the dotted line, bringing A up to B, and forming Fig. 8. Lastly, take the points A, and B, of Fig. 8 between the thumb and forefinger of each hand and pull gently outwards, when the sailing boat will gradually form itself into Fig. 9.

These are quite handy little craft, and if placed on a pond or stream very little wind will be found necessary to send them sailing merrily along.

[Next](#) | [Previous](#) | [Contents](#)

Paper Magic

Will Blyth

[Next](#) | [Previous](#) | [Contents](#)

Army Forage Cap

Here is another type of soldier's hat; one that looks just like the real article and is easily made. The size of paper used will depend upon the fitting required, but a useful size can be made from a sheet of paper about fifteen inches by twenty. The paper must first be folded in half right across the width, as shown by the dotted line of Fig. 10, bringing A, A, down to B, B, and making the paper appear the shape of Fig. 11.

Next fold the corners A, A, of Fig. 11. over to B, at exactly one-third the extreme length of the paper.

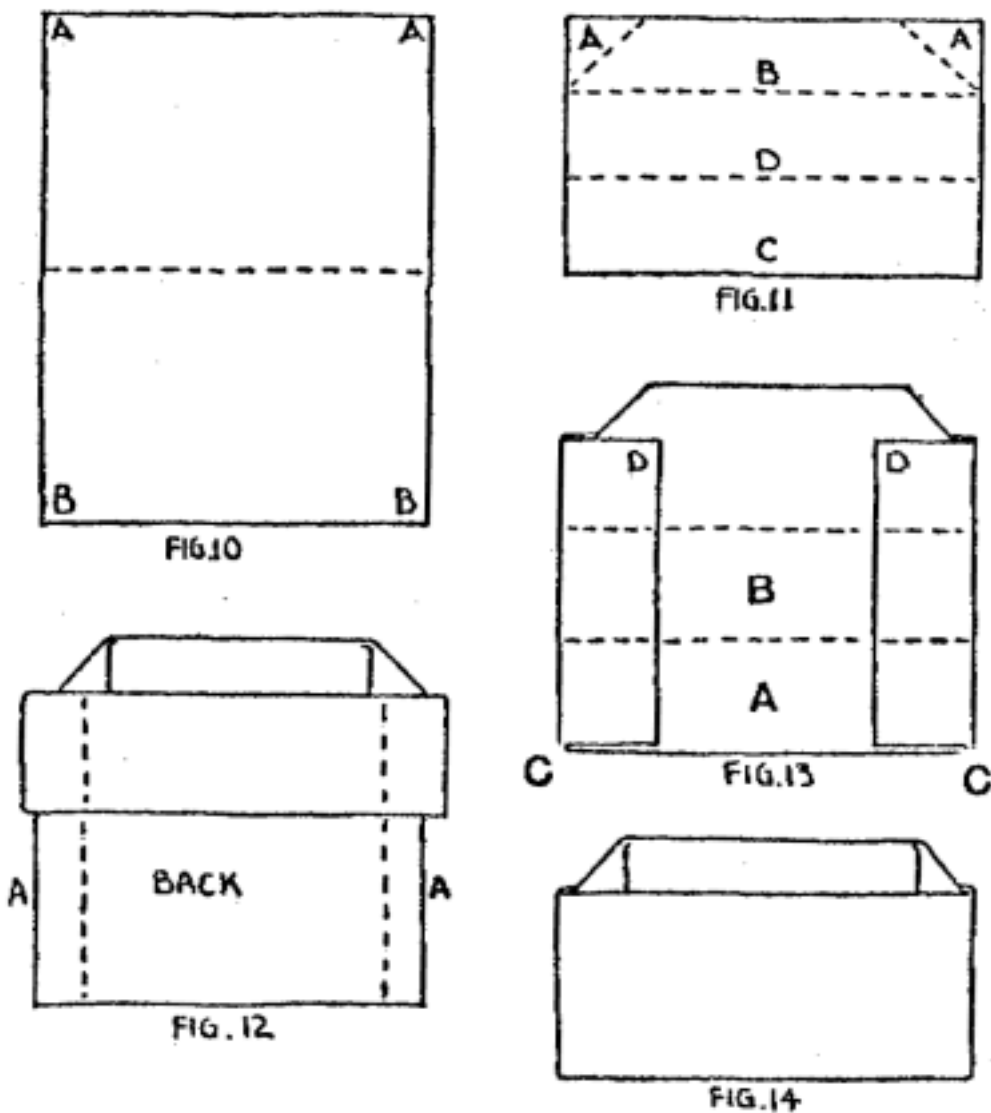

Now fold the top layer of the bottom strip C (representing another third of the paper) up to D, after which, fold D, up to B, making Fig. 12.

The ends A, A, of Fig. 12 must now be turned underneath by bending the paper along the dotted lines, when, if the paper is turned over, Fig. 13 will be revealed. It is important at this stage to note that the ultimate size of the cap is regulated by the width of paper that is turned under Fig. 12. The strips A, and B of Fig. 13 are now folded in a similar way as were the other side strips. Lastly the corners C, C, are inserted inside the corners D, D, which fixes the cap together, and it is then ready for wear as Fig. 14.

[Next](#) | [Previous](#) | [Contents](#)

Paper Magic

Will Blyth

[Next](#) | [Previous](#) | [Contents](#)

Mechanical Conjuring Trick

This is a very clever little paper effect, and fairly easy to make. Take a piece of notepaper about six inches square and fold each of the four corners, A, B, C, and D, of Fig. 15 to the centre, E. Turn the paper over and again fold the four corners to the centre, when the paper will present the appearance of Fig. 16.

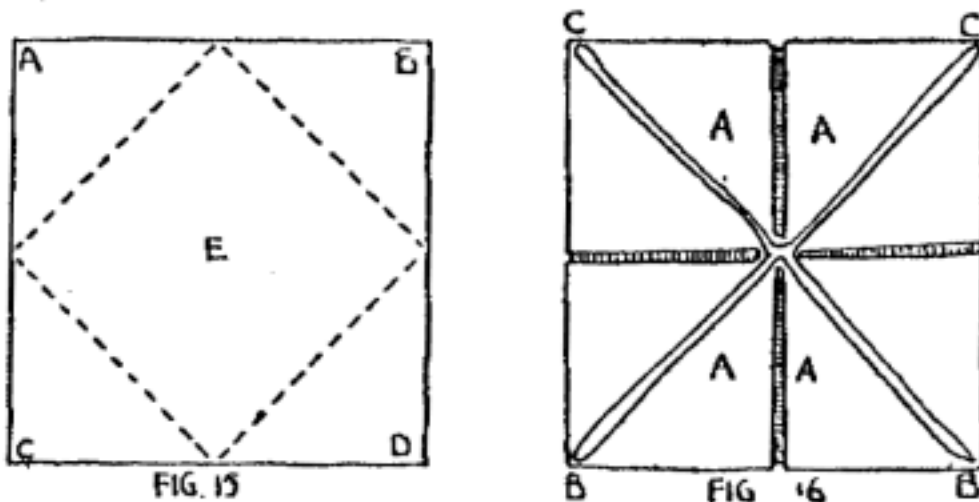

Paint the four triangles A, A, A, A, of Fig. 16 with black paint, and when dry, fold the paper in half, bringing B, B, of Fig. 16 against C, C, and forming Fig. 17. Now pinch the ends A, A, of Fig. 17 and press towards the centre, forcing B, B, outwards, a similar movement being made on the other side. The paper will now form itself into a four-sided diamond-shaped figure with an opening at the bottom of each side. If a finger is placed in each opening; it will be found that by moving the fingers right and left or up and down, either a dark centre or a white centre can be shown as desired. The completed model is shown in Fig. 18.

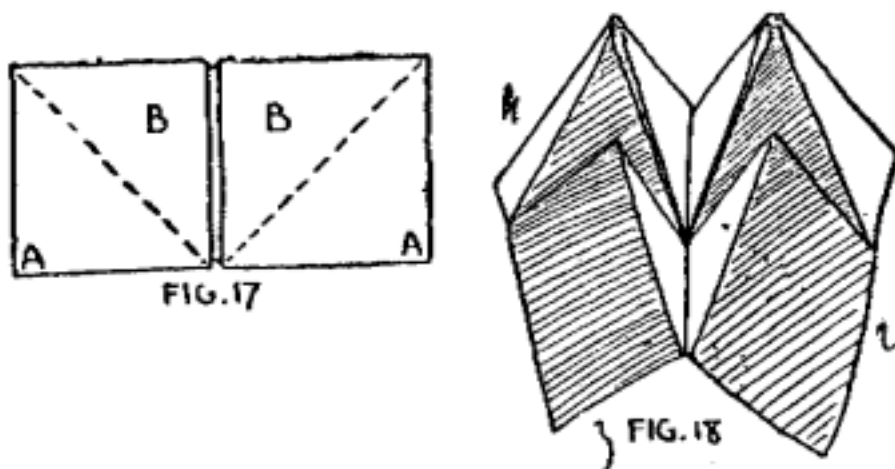

In showing this as a conjuring trick, exhibit the dark side open and then wave the hand in the air, remarking that you "will magically turn black into white" or you may say that "the night will now depart and daylight will appear." Bring the paper again to view with the white portion exposed, but in doing this, make a half-turn with the fingers, thereby turning the paper sideways and making the white part appear the same shape as the black. If this little ruse is not effected, the diamond-shaped opening will in one case be upright, and in the other horizontal; if, however, the half-turn is made as directed, the opening will appear to be the same each time, except that at one time it is black, and then white. Neatly presented the effect is very puzzling.

[Next](#) | [Previous](#) | [Contents](#)

Paper Magic

Will Blyth

[Next](#) | [Previous](#) | [Contents](#)

Breakfast Cruet

The preceding figure is a combined one, in that if turned over and placed upon the table in an upright position it forms a small breakfast cruet, as shown in Fig. 19.

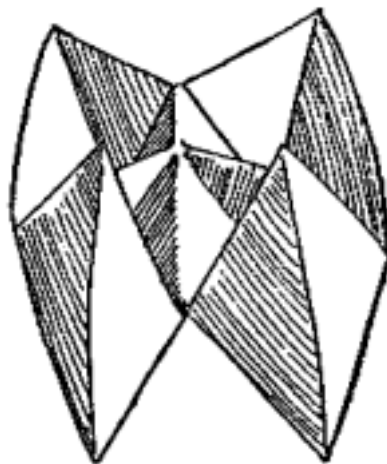

FIG 19.

The tips of Fig. 19 may be turned downwards in order to give the cruet a more substantial appearance for the reception of the condiments. In this position the fold may also be used by children (when acting as shopkeepers) for the display of small goods for sale.

[Next](#) | [Previous](#) | [Contents](#)

Paper Magic

Will Blyth

[Next](#) | [Previous](#) | [Contents](#)

Twin Rowing Boat

Having made the sailing boat, which is a fairly easy fold, the reader is now given the twin rowing boat, a rather more difficult construction, but if the instructions are carefully followed, the folding will not be beyond the powers of the reader.

Take a piece of stout writing paper about six or eight inches square and fold over the corners to the centre, as indicated by the dotted lines in Fig. 15 ([Mechanical Conjuring Trick](#)); the paper will then appear like Fig. 20.

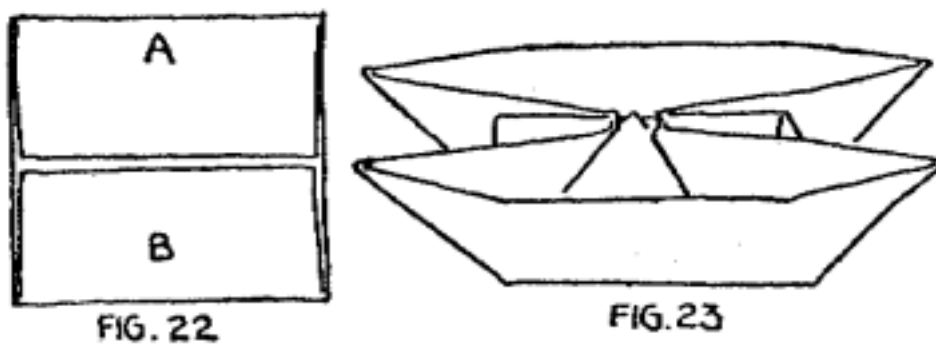
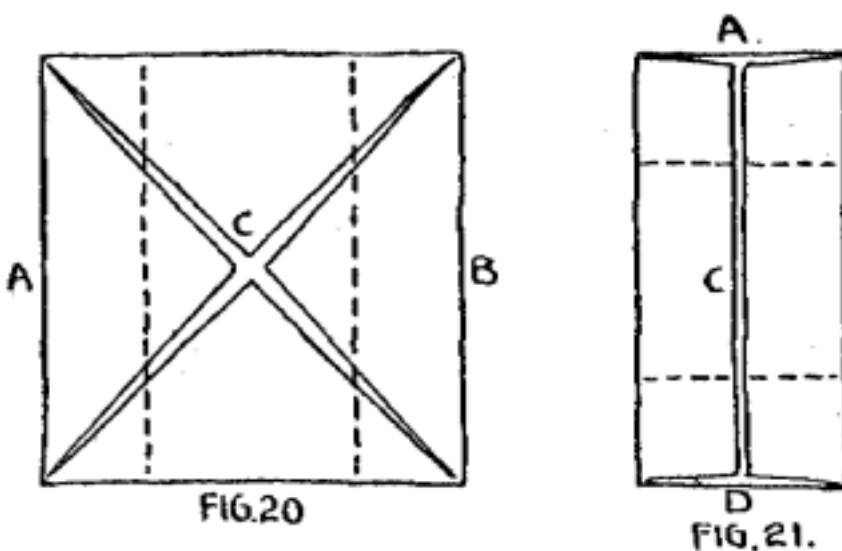

Next fold the sides over to the centre, making the ends A and B, of Fig. 20, meet at the centre C; the dotted lines showing where the folds should be made to form Fig. 21. Repeat the last fold lengthways, thereby bringing the top and bottom edges A, and B, of Fig. 21 to the centre C; the paper now appearing as the solid lines of Fig. 22.

Bend back A and B, of Fig. 22, making the paper half the size of Fig. 22.

Now comes rather a difficult move to explain in print, but the method of folding can easily be followed by the diagrams. In the centre of the top part of Fig. 22, after folding it in half, will be found four points or corners--take two of these between the thumb and forefinger and pull gently upwards and outwards to the extent of the end points seen in Fig. 23, at the same time pressing the inside quite flat. This movement will be more easily understood if one of the double ends of Fig. 23 is studied, which clearly indicates the position after the fold has been made. Repeat this operation at the other end, and the twin rowing boat is then complete as Fig. 23.

[Next](#) | [Previous](#) | [Contents](#)

Paper Magic

Will Blyth

[Next](#) | [Previous](#) | [Contents](#)

Pin Tray

This item, while interesting to make, is also a useful little article for the office desk or workbench, and can be utilised in many ways for the reception of odds and ends. A piece of stout writing paper about six inches square will be required. Fold the sides A, A, of Fig. 24 over to the centre B, making the folds along the dotted lines. The paper will then appear like Fig. 25.

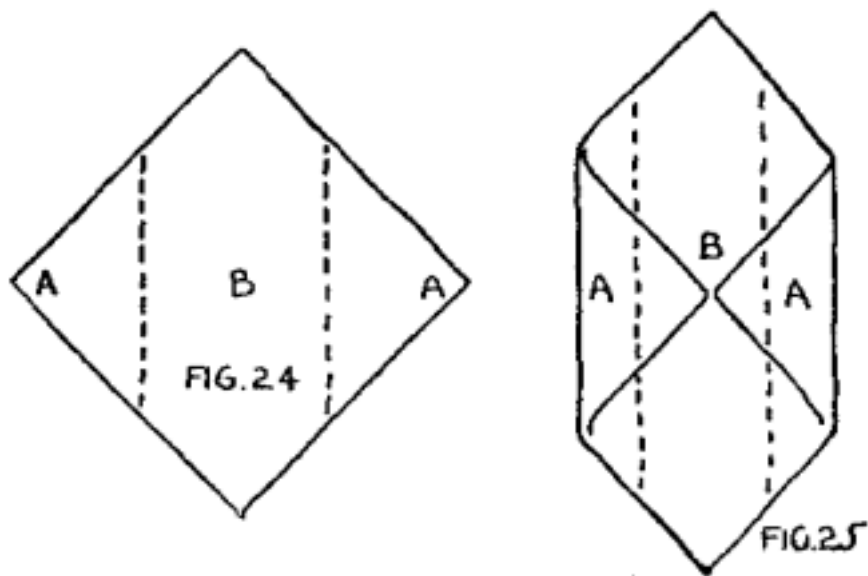

Make two similar folds to Fig. 25 as indicated by the dotted lines, which will bring the outside edges, A, A, to the centre B and forming Fig. 26. Fold Fig. 26 in half, backwards, bending at the dotted line, thus making the back of the bottom point B, touch the back of the top point A, and the paper will now appear as Fig. 27.

The front portion of Fig. 27 is now turned over on itself by inserting the two forefingers under A, and B, and pulling outwards and downwards, gradually forming Fig. 28. The paper is pressed flat after this operation. There is nothing very difficult about this fold, and the reader is advised to note C, C, and D of Figs. 28 and 29, which show the positions of the various points both before and after the folding.

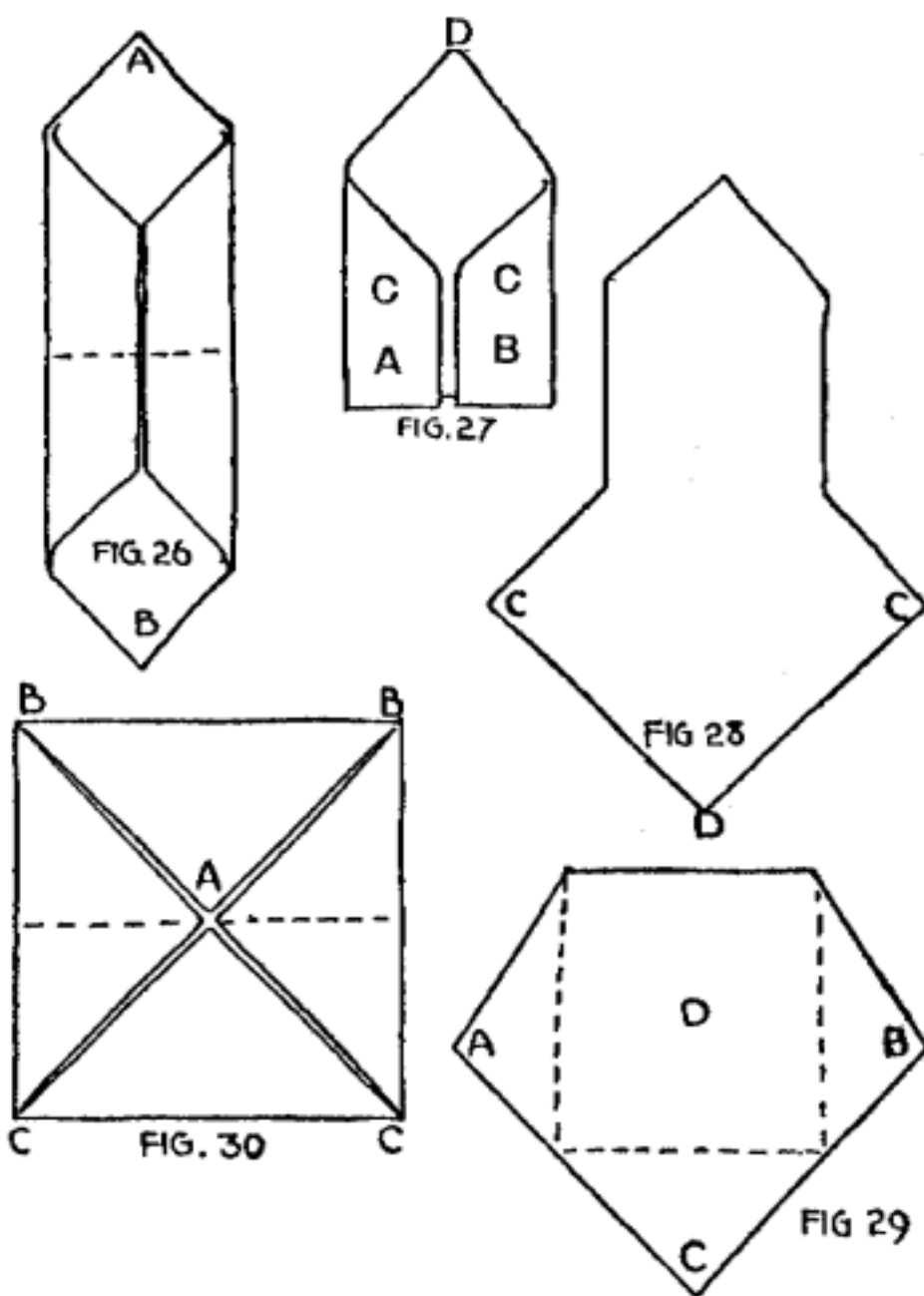

Now turn the paper over and make a similar fold on that side, which will give Fig. 29. The three corners, A, B, and C, Fig. 29 are next brought to the centre D, by folding along The dotted lines. Again the paper is turned and the movement repeated on the other side, thus forming Fig. 30.

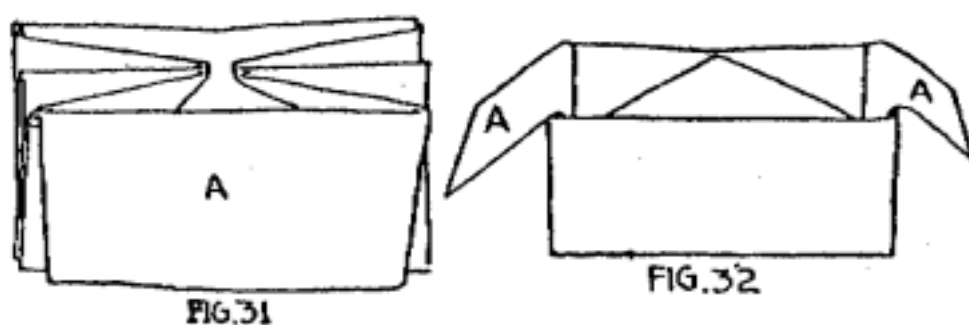

The top portion A, of Fig. 30 is turned down on both sides by bending along the dotted line and thus bringing the points B, B, down to the points C, C, and forming Fig. 31. This completes the folding of the pin tray which is now in a flattened condition. To open out, take the flaps A, of Fig. 31 on both sides of the paper, between the thumb and forefinger of each hand and pull gently apart, when the pin tray is revealed as in Fig. 32.

[Next](#) | [Previous](#) | [Contents](#)

Paper Magic

Will Blyth

[Next](#) | [Previous](#) | [Contents](#)

Ash Tray

This is a very easily made little model, yet like its more intricate prototype, the Pin Tray (Fig. 32), it will be found very useful for the reception of various odds and ends. Take a piece of stout paper about four inches by six and well crease the paper, as shown by the dotted lines of Fig 33, the small corner creases being made after the longer surrounding lines have been well pressed into the paper. Note also, that the side pieces are narrower than the top and bottom ones.

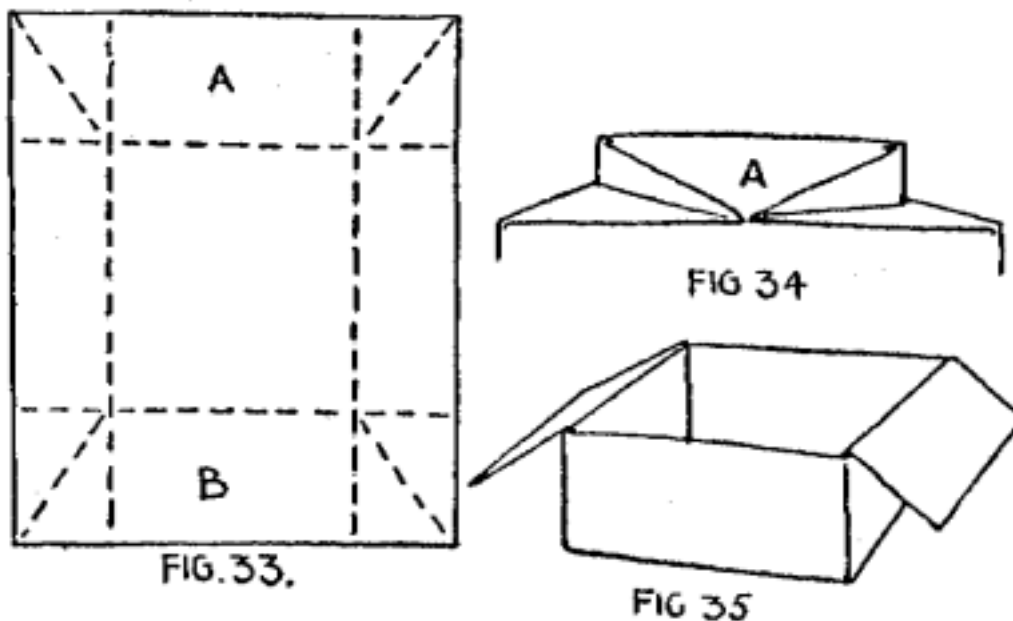

Bend up the ends A, and B, of Fig. 33 and pinch each corner inwards, which will have the effect of bringing up the sides into position. The appearance of one of the ends after doing this is shown in Fig. 34.

The flaps A, one of which is seen in Fig. 34, are finally bent over along the dotted line, thereby covering B, when the Ash Tray is complete as Fig. 35.

[Next](#) | [Previous](#) | [Contents](#)

Paper Magic

Will Blyth

[Next](#) | [Previous](#) | [Contents](#)

Saucepan

A novel and surprising use to which the pin tray may be put is to boil water. This is best effected over the flame of a candle. The tray, or saucepan as it should now be called, being supported on the top of a candle shade holder, as shown in Fig. 36.



The water must be put into the paper saucepan before the candle is lighted, otherwise the paper will ignite. There is an interesting scientific reason why the paper will not burn while the water is inside: the water cannot, of course, get hotter than boiling point, and as it will not, or cannot allow the paper to get above that point also, it will be seen that there is not, sufficient heat for combustion to take place.

[Next](#) | [Previous](#) | [Contents](#)

Paper Magic

Will Blyth

[Next](#) | [Previous](#) | [Contents](#)

Kettle

This is another little article for the purpose of boiling Water, but the method of folding is far more ingenious than the paper saucepan just dealt with. The latter was quite open at the top, but in the case of the kettle the water is completely covered and contained within the paper. Take a piece of stout note paper. The size will naturally depend upon the required capacity of the finished "kettle," but a piece about six to eight inches square will be found very convenient. Fold this horizontally, perpendicularly and diagonally, as indicated by the dotted lines in Fig. 37, well pressing the folds down with a flat ruler or paper knife, so that the folding marks are well impressed into the paper.

Fold Fig. 37 in half horizontally so that the bottom corners A, touch the top corners B, B, and Fig. 38 is formed. Turn the triangular corners A, A, of Fig. 38 inside the centre triangles B, B, which will bring the points C, C, inside B, B, up to the centre point D when the paper will appear like Fig. 39.

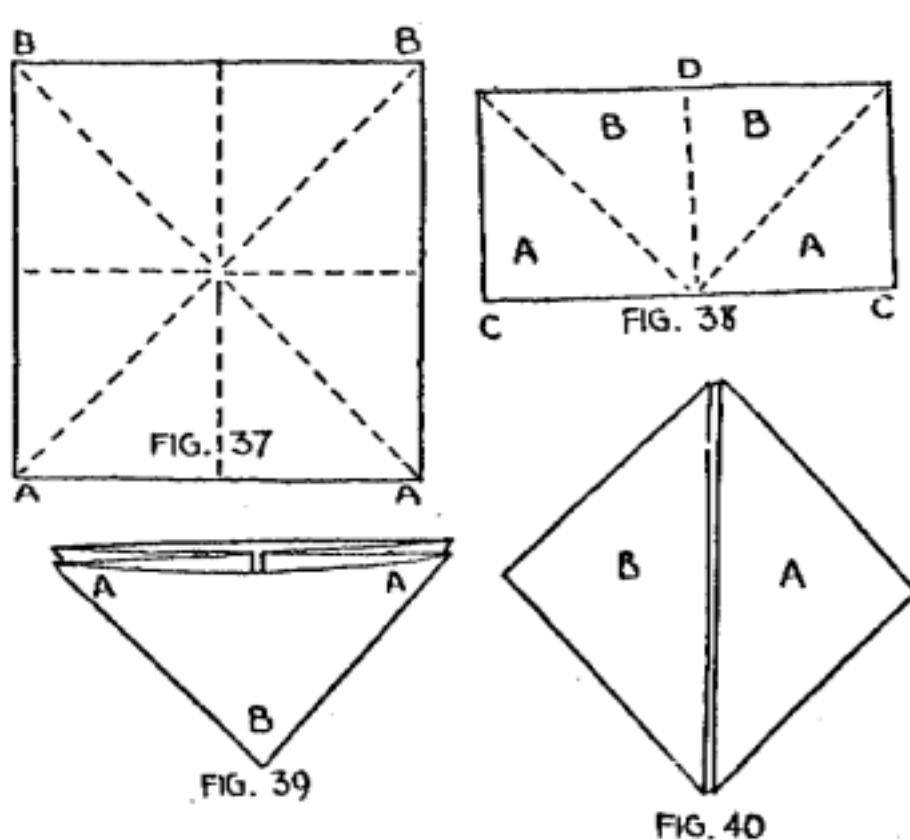

The top corners A, A, of Fig. 39 must now be folded down to the bottom point B, the paper then reversed and the fold repeated on that side, giving the paper the appearance of Fig. 40. Now comes the most difficult move of the whole operation, so follow the instructions very carefully. Unfold the side A, of Fig. 40 in order to form Fig. 41; then fold the end A, over to the front, bending along the dotted line, thus making Fig. 42.

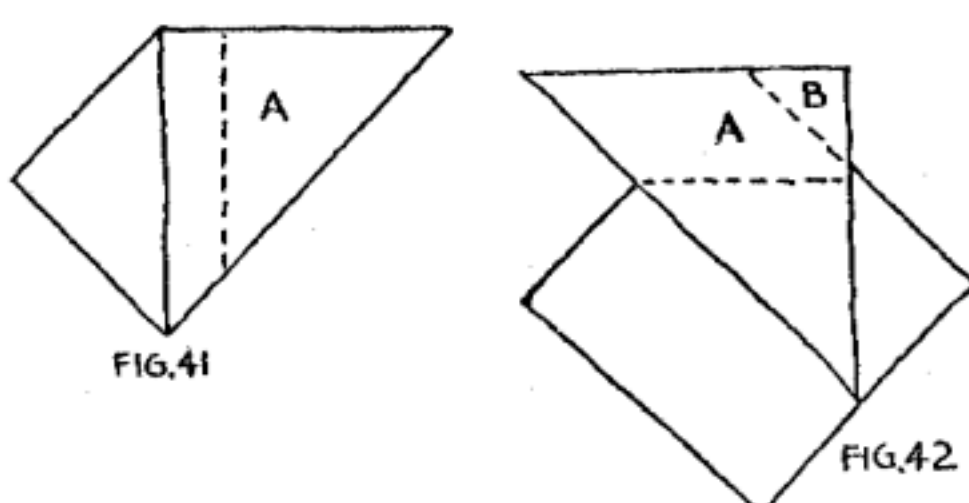

Next bend over the top part of Fig. 42 marked A, along the lower dotted line, and at the same time open out and press quite flat the little double triangular corner B, of Fig. 42 into the position of B, of Fig. 43. These explicit instructions and diagrams should make this move quite clear to the reader, who will find that his paper has assumed the appearance of Fig. 43.

Fold back the pointed end A, of Fig. 43 to the right, leaving the left side clear. Now repeat the manipulations just described, and illustrated in Figs. 41, 42 and 43, to the left side of the paper, i.e. B, of Fig. 40.

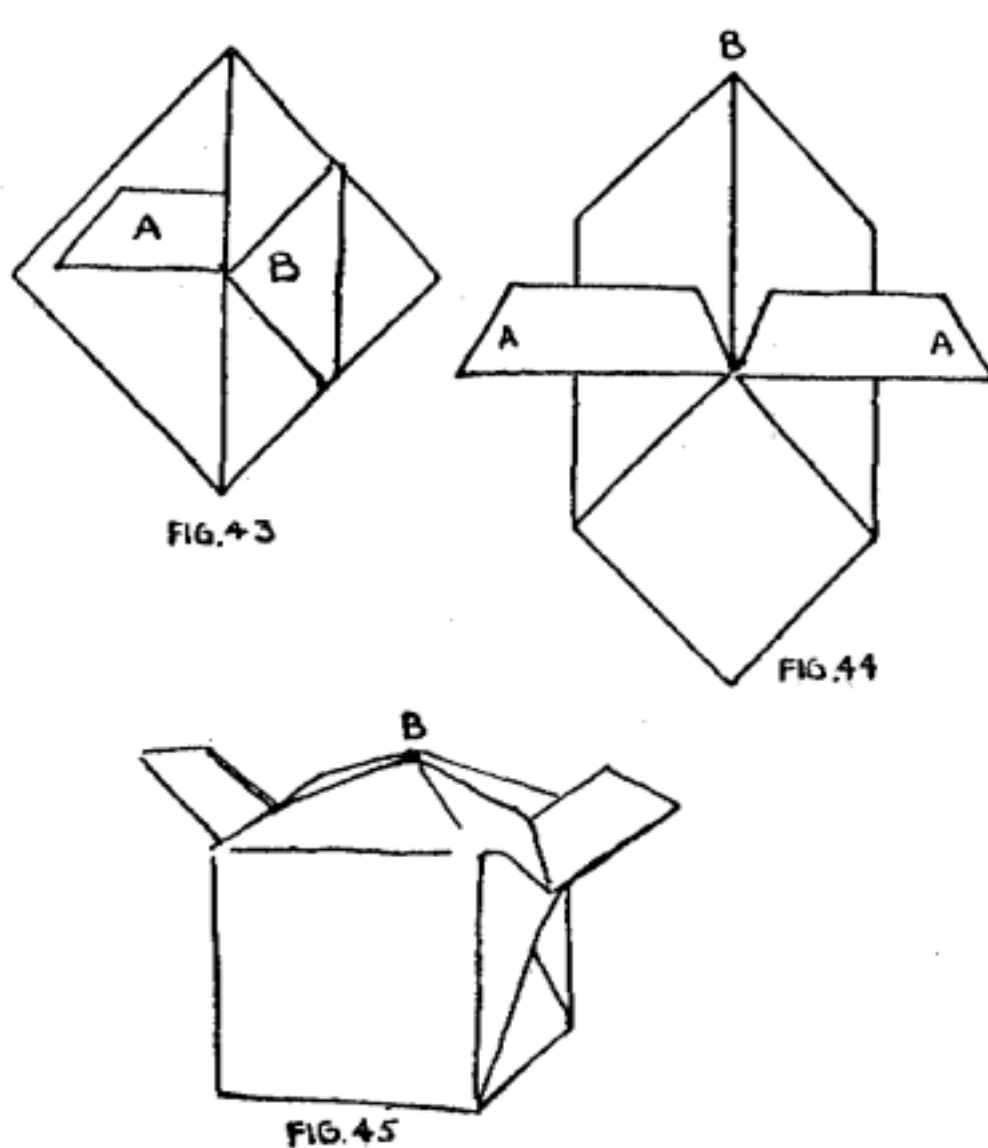

Next turn the paper over and repeat the folds on that side as set forth in Figs. 41, 42 and 43, the result being that both sides will now appear similar to Fig. 44. Bring the two tabs A, A, of Fig. 44 together on both sides and holding with the thumb and forefinger of each hand, pull slightly, at the same time blowing into the small hole which will be found at the top, and marked B, in Figs. 44 and 45. The paper is thus gradually "coaxed out," and, after pressing the sides and bottom edges, the kettle will appear as Fig. 45. This can now be filled with water and suspended over the flame of a candle in a similar way to the saucepan, as described and illustrated on page 13. It will be found that the water will boil without injuring the home-made kettle in any way.

[Next](#) | [Previous](#) | [Contents](#)

Paper Magic

Will Blyth

[Next](#) | [Previous](#) | [Contents](#)

Working Bellows

This fold is not difficult to make, and the effect of the force of air expelled in working the bellows makes the model very novel and interesting. To make this, proceed with the folding of a stout piece of writing paper as instructed in the foregoing fold of the kettle, carrying the folding up to the stage of Fig. 40, the shape of the paper being reproduced in Fig. 46.

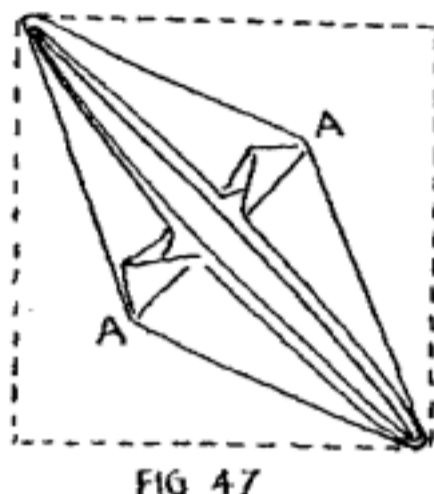
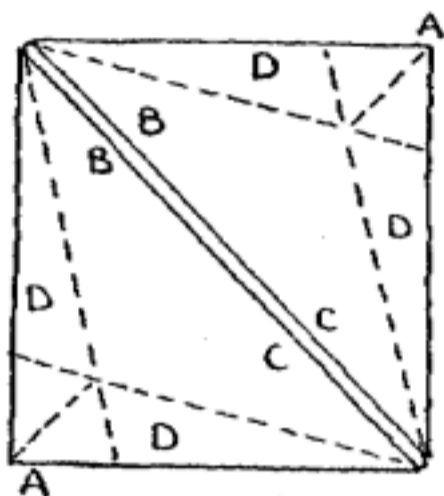

Several creases similar to dotted lines of Fig. 46 have now to be made in each of the four sections, i.e. the two in front of Fig. 46 and the two which will be found at the back. The creases must be well pressed into the paper with a flat ruler or the back of a tableknife, and the subsequent folds will then readily adapt themselves as required. To make the creases, fold over the points A, A, of Fig. 46 over to B, and after the crease has been well pressed into the paper, open out the paper again. Then fold A, A, again, this time over to C, emphasising the creases as before, and afterwards opening out the paper. The long dotted lines of Fig. 46 will show where the creases should now appear in the paper. Lastly, pinch together the two little corners lettered A, of Fig. 46 in the centre, along the dotted line shown, so that the top part of A, or that part exposed to the view in Fig. 46 is pressed inside. Hold one of the little ends, or tabs, between the thumb and forefinger and fold the section over to the centre B, B, and C, C, which will bring the outside edges D, D, D, D, of Fig. 46 level with the centre line. After this fold has been made in the two front sections, the paper will present the appearance of Fig. 47. Now turn the paper over and fold the two tinder sections in a similar manner, after which the working bellows is complete as seen in Fig. 48.

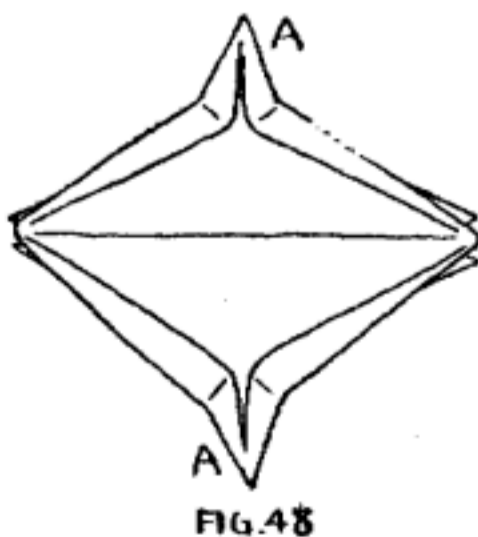

It will be found that by taking a pair of the little tabs A, A, of Fig. 48, together in the fingers of each hand and working the model inwards and outwards, the bellows will prove itself to be a thoroughly practical working article.

[Next](#) | [Previous](#) | [Contents](#)

Paper Magic

Will Blyth

[Next](#) | [Previous](#) | [Contents](#)

Lifeboat

This pretty realistic little model is a further development of the pin tray (Fig. 32). The side flaps, A, A, of Fig. 32 are first pressed against the side of the tray and the top edges of the opposite sides, i.e. those without any flaps, must be bent over outwards to the bottom outside edges of the tray. It will, of course, only be possible to make the edges meet in the centre part of the bottom and the ends must, therefore, be neatly pressed into the corner angles, so that they can be made quite flat. This operation is not really a difficult matter and the appearance of the paper at either end after the above fold has been made can be seen in Fig. 49.

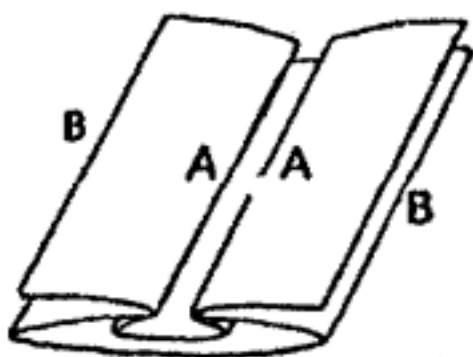

FIG. 49

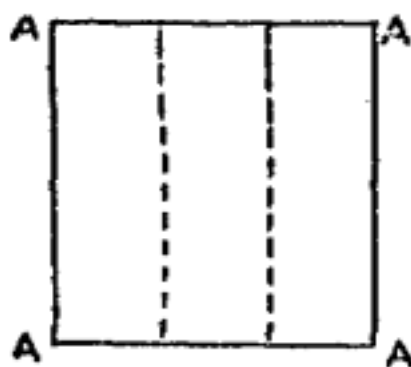

FIG. 50

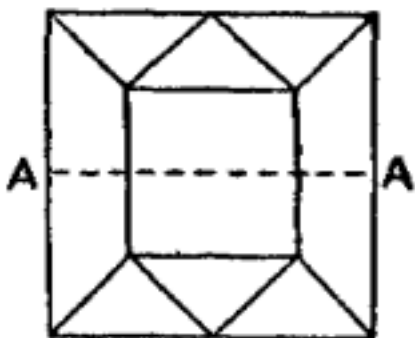

FIG. 51

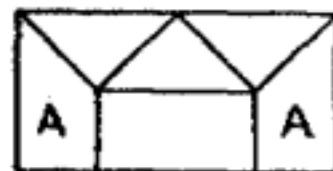

FIG. 52

The top halves of Fig. 49 have now to be turned underneath. If Fig. 49 is turned over you will find a plain square back similar to Fig. 50. Bend the edges A, A, A, A, of Fig. 50 over to the centre B, B, by folding along the dotted lines. Thus the outside edges B, B, of Fig. 49 will form the new centre of Fig. 50, the inside edges A, A, of Fig. 49 forming the outside edges of Fig. 50. The effect of this movement is that the whole of the upper part of Fig. 49 covers the square of Fig. 50 making the reverse side appear similar to Fig. 51. Now fold Fig. 51 backwards, folding along the dotted line and so form Fig. 52.

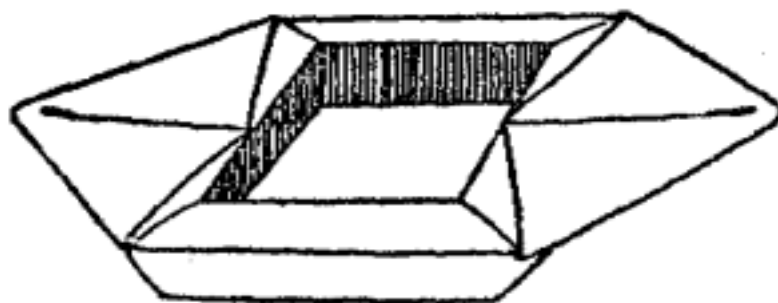

FIG. 53

Finally, take the ends A, A, of Fig. 52 between the thumb and forefinger of each hand and pull carefully and gently outwards, when the lifeboat will slowly evolve as Fig. 53.

[Next](#) | [Previous](#) | [Contents](#)

Paper Magic

Will Blyth

[Next](#) | [Previous](#) | [Contents](#)

Chinese Junk

This is an old schoolboy fold, but to many the difficulty of manipulation has been too great for them to attempt the folding. It is hoped, however, that the explicit instructions in this book will be found sufficiently clear to enable every reader to make this culminating paper effect. The reader has now been led by progressive stages to Fig. 53 ([the lifeboat](#)), and the final formation of the Chinese junk from this model is mere child's play.

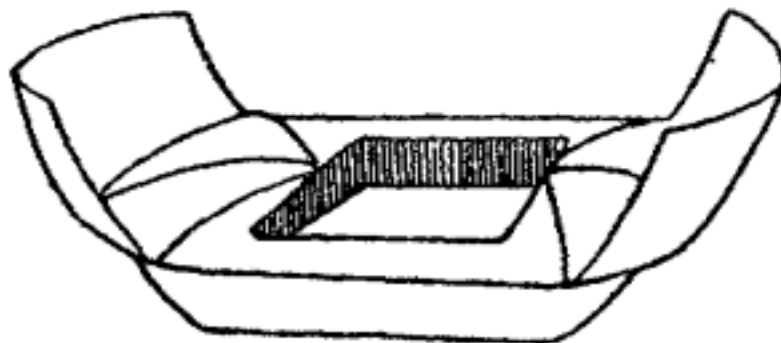

FIG. 54

At each end of what might be termed the "deck " of the lifeboat, will be noticed four triangular shaped pieces. The top layer of paper forming these pieces must now be carefully raised into a perpendicular position to the extreme ends, when it will be found that the chinese junk as seen in fig. 54 is an accomplished fact.

[Next](#) | [Previous](#) | [Contents](#)

Paper Magic

Will Blyth

[Next](#) | [Previous](#) | [Contents](#)

Flying Aeroplane

This is a regular up-to-date little model and will be found to be a very amusing and practical toy for flying indoors or in the open air. Take a piece of paper about six by eight inches and fold the bottom corner A, of Fig. 55 up to B, as shown by the dotted line, C, D. Well press the line into the paper and open out again. Then fold C, up to D, folding along the dotted line A, B, and press the crease well into the paper as before, and re-open the paper.

Now refer to Figs. 38, 39 ([Kettle](#)) and fold the lower square of paper under the slip lettered E, of Fig. 55 as directed by the instructions for Figs. 38 and 39. After these folds have been made, the only difference in the appearance of the paper to Fig. 39 is that the top slip E, is added, as indicated in Fig. 56. Now turn the top points A, A, of Fig. 56 down to the bottom point B, by folding along the dotted lines shown, when the paper will appear like Fig. 57.

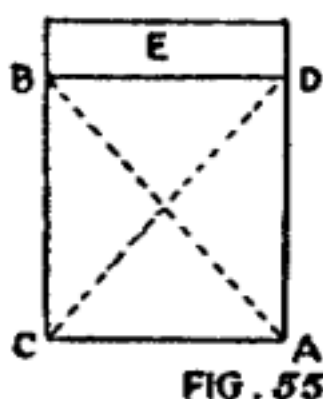

FIG. 55

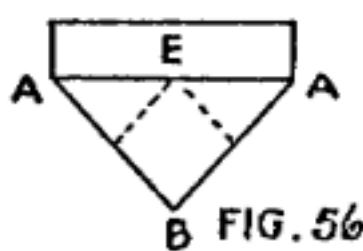

FIG. 56

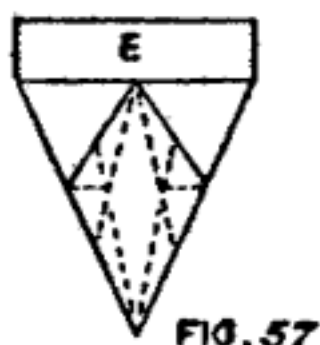

FIG. 57

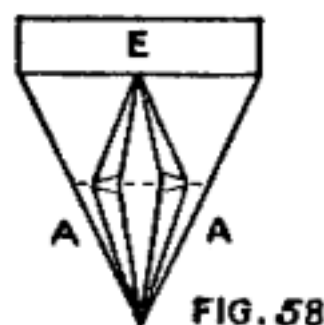

FIG. 58

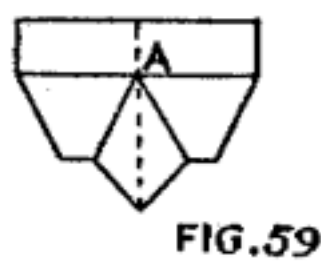

FIG. 59

A similar fold is now made to that of the [Working Bellows](#) (Figs- 46 and 47); folding along the dotted lines shown in Fig. 57 which will give Fig. 58. (Full instructions for this movement will be found here). Next fold the lower portion of Fig. 58 lettered A, A, along the dotted line and bend it right under the upper part of the paper and thus make Fig. 59.

Now make a V shaped bend along the dotted centre line of Fig. 59 which will complete the manufacture of the body of the aeroplane, and there now remains only the tail to be made, an extremely simple operation. For this, a slip of paper about one by nine inches is required. Bend this also into a V-shape down the centre, lengthways, and insert the end into the body of the aeroplane at the centre point A, of Fig. 59. Temporarily straighten up the turned over corner A, A, of Fig. 58 in order to push the tail piece well home, rebending the point A, A, again when this has been done. It will be found that this little manoeuvre keeps the tail piece locked in the point A, A.

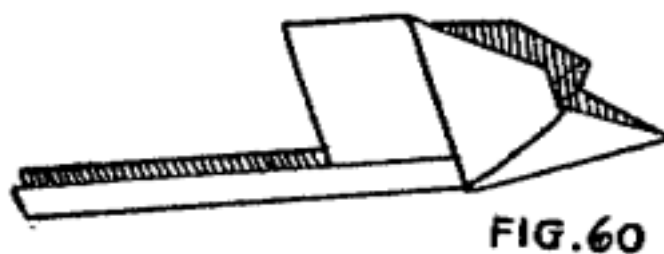

FIG. 60

The Flying Aeroplane is now complete as Fig. 60, and if held at the underside with the tips of the thumb and forefinger and propelled forwards, it will be seen to sail for a fairly long distance in a most aeroplane-like manner.

[Next](#) | [Previous](#) | [Contents](#)

Paper Magic

Will Blyth

[Next](#) | [Previous](#) | [Contents](#)

Christmas Star

This is a very useful fold to learn for decorative purposes, and at Christmas time, when the Star of Bethlehem is brought so prominently before us. It is particularly appropriate for placing upon Christmas Trees or among the holly and evergreen festoons. The stars may be made in various coloured papers and produce a really charming effect, affording a pleasant and useful occupation and pastime for the younger members of the family during the days preceding our national Yuletide festival.

Some paper ribbon, half an inch wide, is all that is required for a small star; for a larger one, use ribbon from one to two inches wide. These are easily cut from the coloured papers usually made into chain decorations, or even newspaper can be used, according to the pleasure of the maker of the stars. To make a star, take four strips of half-inch paper ribbon, about nine inches long, and folding each in half, place them together as shown in Fig. 61. Passing A through the double end of I and so on.

The various shadings will enable readers to see how each of the four strips could be used.

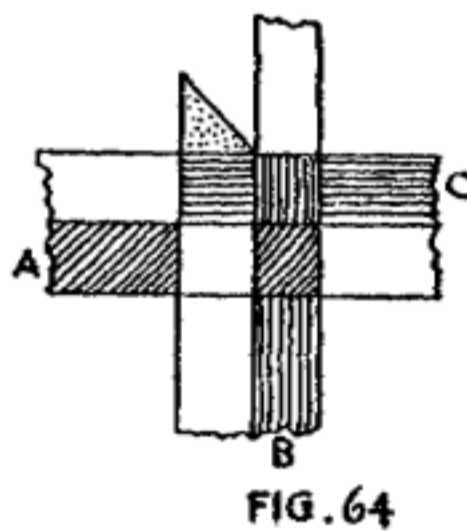
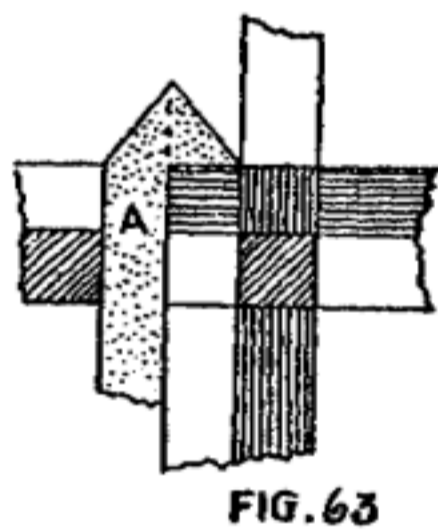
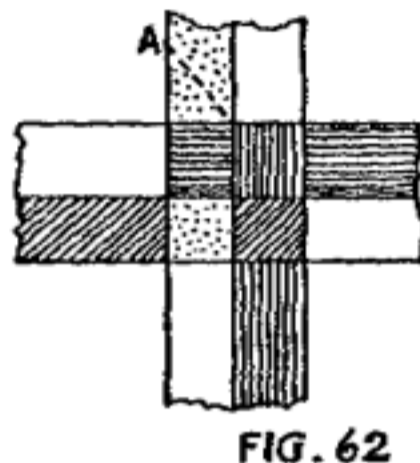
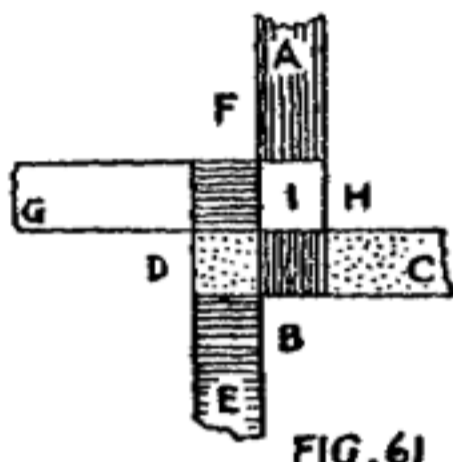

Now bend the top strip of A, of Fig. 61 over to B, the top strip of C across to D, the top strip of E, up to F, and the top strip of G, across to H, passing the end of G, underneath I, in order to lock the folds, which will now appear similar to Fig. 62. Each of the eight strips of Fig. 62 surrounding the centre square have now to be turned into triangular points. The shaded and dotted strips belong, to the front and are folded first; the white strips belong to the back, and are folded last. Turn the strip A, of Fig. 62 to the back, bending along the dotted line. Fold again to bring strip A, to the front, thus forming Fig. 63.

Now fold the strip A, of Fig. 63 over to B, folding along the dotted line, and then pass the end of the strip of paper under B. Tear off any surplus of the strip which protrudes, and the point is then formed as Fig. 64.

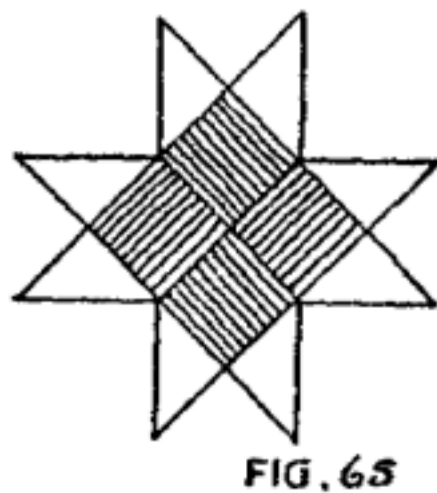

The ends A, B, and C, of Fig. 64 are next made into points by the same process as just described for A, of Fig. 62. After which the paper is turned over and the four strips on the back made into points as the front side strips were, thus completing the star which appears like Fig. 65.

[Next](#) | [Previous](#) | [Contents](#)

Paper Magic

Will Blyth

[Next](#) | [Previous](#) | [Contents](#)

Easter Cross

Having made the [Christmas Star](#), it is an easy matter to construct an Easter Cross, since it is only necessary to make seven stars and fit them together with the points inside each other, when the Easter Cross is complete as Fig. 66.

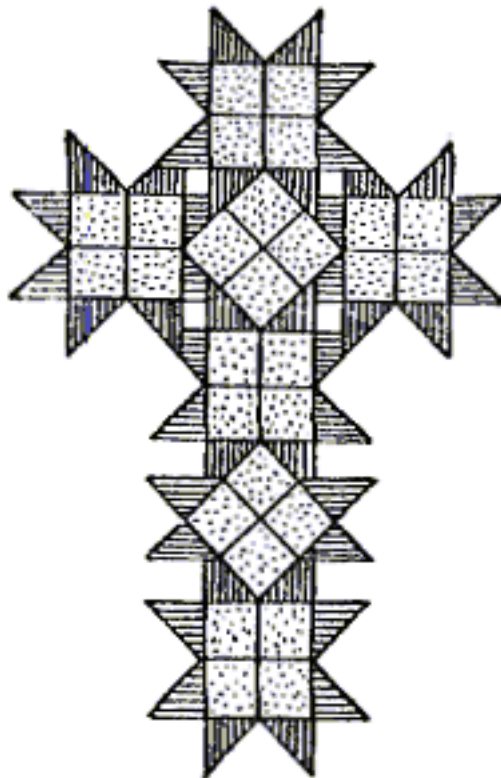

FIG. 66

It should be noted that the centre squares are fitted together in alternate positions, i.e. diagonal and diamond shaped. This enables the points to fit more closely into each other and makes the cross more compact. It is advisable to paste some paper along back, thus binding the stars together and making the cross more permanent. A handsome centre piece may be made, suitable for Church decoration at Easter, if two-inch paper is used for the stars.

[Next](#) | [Previous](#) | [Contents](#)

Paper Magic

Will Blyth

[Next](#) | [Previous](#) | [Contents](#)

Dart

This little toy is very popular with boys and is capable of making fine flights in the air, moreover the manufacture is a very simple matter. Take a piece of paper about nine inches by twelve as Fig. 67 and fold the corner points, A, A, up to the centre B, bending along the dotted lines which will give Fig. 68.

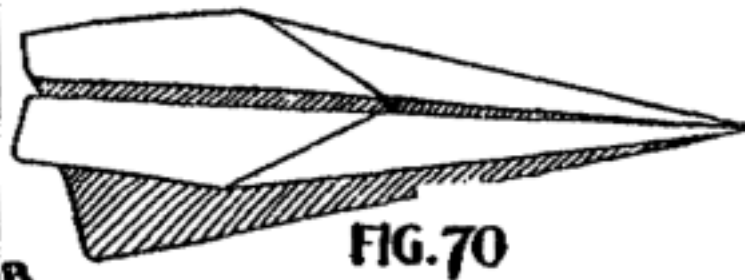
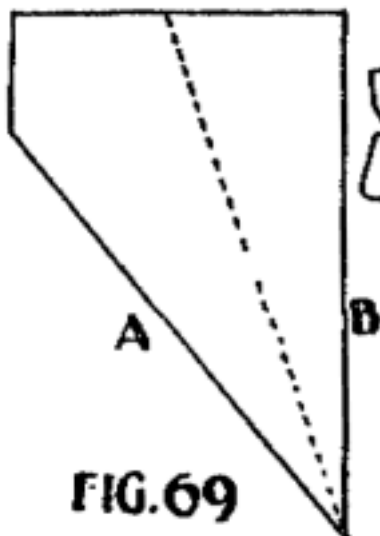
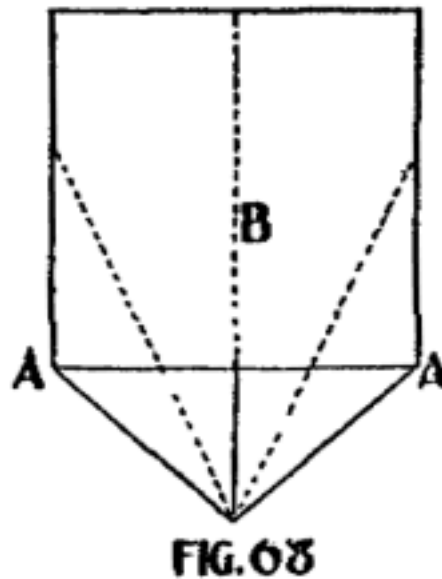
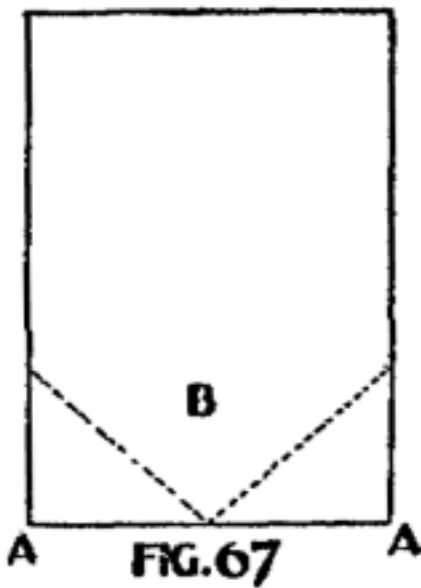

Next fold the corners A, A, of Fig. 68 to the centre B, by bending the side dotted lines and then double the paper by folding along the centre dotted line, thus making Fig. 69.

Finally fold the edge A, of the top layer of Fig. 69 over to B, by folding along the dotted line, turning the paper over and repeating the fold on the other side when the dart is complete as Fig. 70 and ready for action.

[Next](#) | [Previous](#) | [Contents](#)

Paper Magic

Will Blyth

[Next](#) | [Previous](#) | [Contents](#)

Parachute

These fascinating creations provide endless sport in the open air and well repay the trouble of making them. It is better, however, to go out "flying" with several prepared parachutes, since they are more often than not blown out of reach of the owner. They are best made with tissue or foreign note paper, which must be made circular and with rounded little projections along the edge. The easiest method of effecting this is to fold a square of the paper in half, and then in half again, making it one quarter its original size. Next fold one corner to the opposite corner, making a triangular shape similar to Fig. 71.

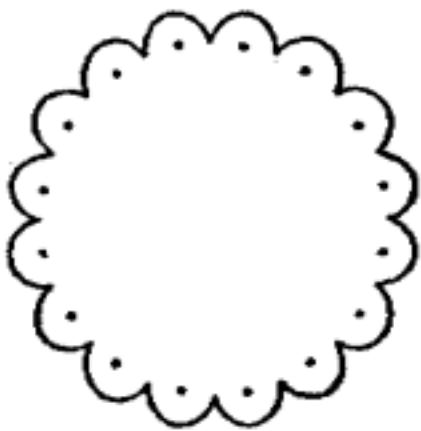
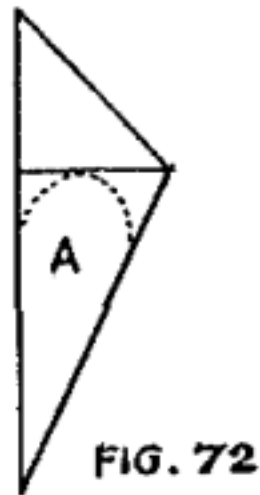
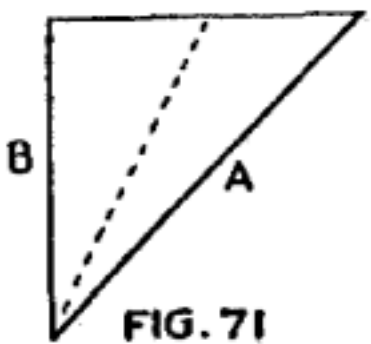

Now fold along the dotted line of Fig. 71, bringing the edge A over to B, and forming Fig. 72. Next cut around the dotted line at the top of Fig. 72 and open out the lower piece lettered A, which will be found as represented in Fig. 73.

Threads are now fixed to the points indicated in Fig. 73, the free ends being joined together round a cork or folded piece of paper, the exact weight required to properly balance the parachute will depend a great deal upon the velocity of the wind at the time of flying, and also upon the weight of the paper forming the body of the model. The parachute is then finished and will appear as Fig. 74. When properly weighted and released in the air, the body fills out with air and glides gracefully along.

[Next](#) | [Previous](#) | [Contents](#)

Paper Magic

Will Blyth

[Next](#) | [Previous](#) | [Contents](#)

Flap Purse

This is not really a practical article, since anybody would be very venturesome who endeavoured to bank any cash in this home-made receptacle for wealth. It is a somewhat difficult fold, yet nevertheless interesting and ingenious and well worth the effort required to produce. To make, take a piece of paper about eight inches square and fold each way into three equal parts as shown by the dotted lines of Fig. 75, which will give a small square similar to Fig. 76.

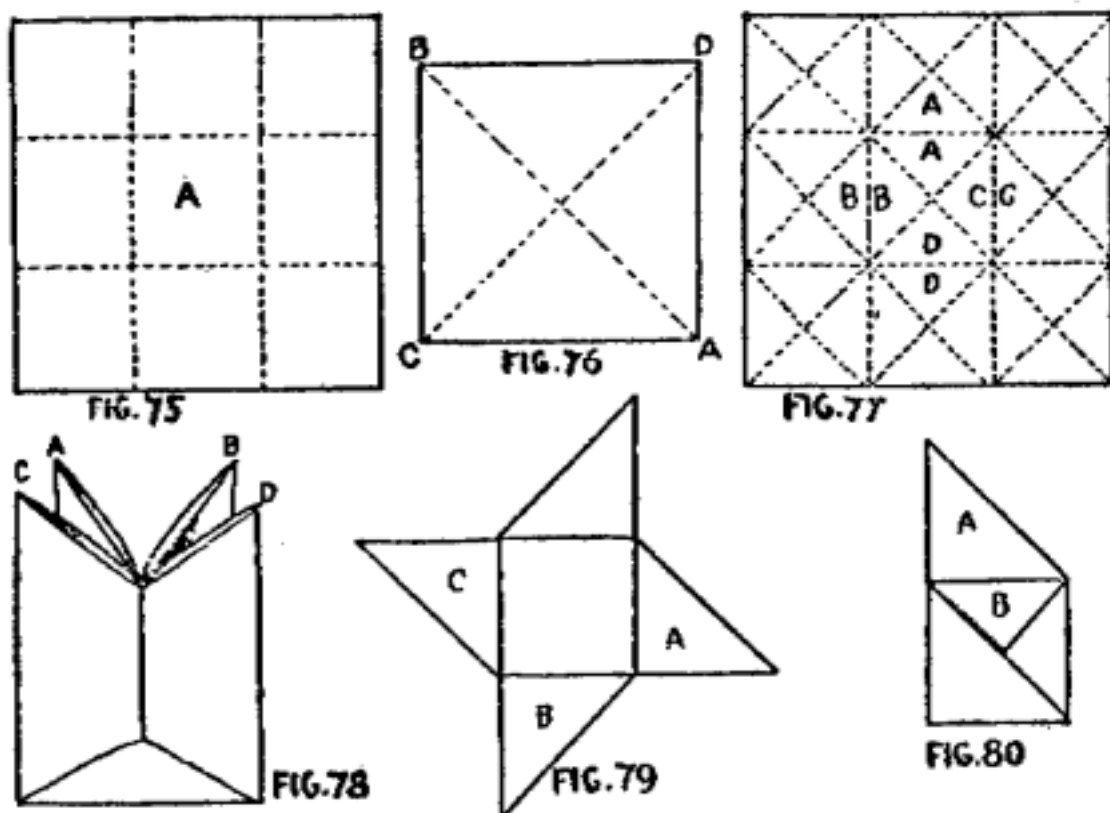

Now bend the corner A, of Fig. 76 up to B and well press the dotted line, C, D, into the paper. Open out again and fold C, up to D, this time pressing the dotted line A, B, well into the paper. Now pinch each corner inwards, which will have the effect of forming a star-shaped figure; this must now be pressed quite flat, when the paper will appear similar to Fig. 40 ([Kettle](#)). Now open out the paper entirely, when it will be found to be marked as Fig. 77.

Next comes a rather intricate fold and one not very easily explained either in print or by diagram. If, however, the dotted lines seen in Fig. 77 have been well pressed into the paper, the folding will be rendered less difficult. The four sides must first of all be drawn up to the centre so that A, of Fig. 77 comes on the top of A; B on B; C on C; and D on D, making the fold appear something like Fig. 78. The points A, B, C, and D, of Fig. 78 are now bent down to form Fig. 79, the folds in the paper assisting them into their places. It might be noted here that the centre square A, of Fig. 77 is the same square seen in the centre of Fig. 79, the latter square, however, is now covered with the four double triangular pieces of paper A, A, B, B, G, C, and D, D, of Fig. 77.

Now turn A, of Fig. 79 under the centre square; then B, and finally G, the paper when turned over appearing like Fig. 80. The point A at the top of the flap of Fig. 80 is now inserted in the opening lettered 13, in Fig. 80 and the Flap Purse is finished.

[Next](#) | [Previous](#) | [Contents](#)

Paper Magic

Will Blyth

[Next](#) | [Previous](#) | [Contents](#)

Puff Ball

This is a very novel paper combination which can be used either as a puzzle, a toy, or a game for several players. The ball is best made of stout writing paper, and three round pieces of about three inches diameter will be required. The three pieces must be cut with a sharp penknife or pair of scissors, as indicated by the dotted lines in Figs. 81, 82 and 83.

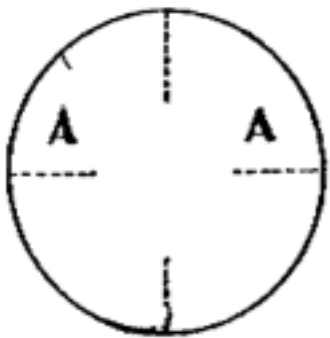

FIG. 81

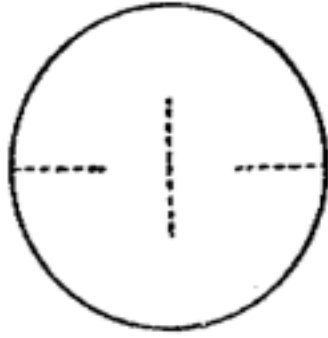

FIG. 82

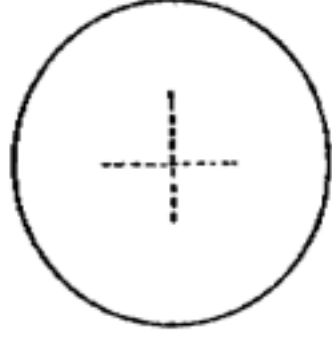

FIG. 83

Lightly fold the two side pieces marked A, A, of Fig. 81; and pass the upper half of Fig. 81 through the centre slit of Fig. 82. Afterwards opening out the lightly folded ends of Fig. 81, which will give Fig. 84. Now in a similar manner lightly fold the four top halves marked A, A, A, A, of Fig. 84 (only three of which can be seen in the diagram) and pass them through the centre star cuts of Fig. 83. This can be easily managed by holding the folded ends lightly between the four fingers of the right hand, when they can be gently passed through the centre cuts of Fig. 83, which is held in the left hand. Thus the puff ball is completed as seen in Fig. 85. The ball may be used as a puzzle by asking anyone to get it to pieces and put it together again without tearing the papers.

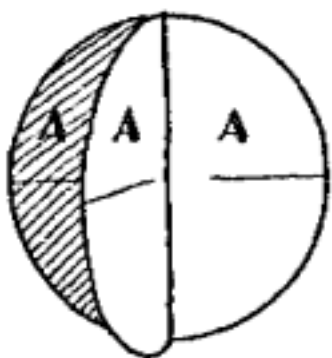

FIG. 84

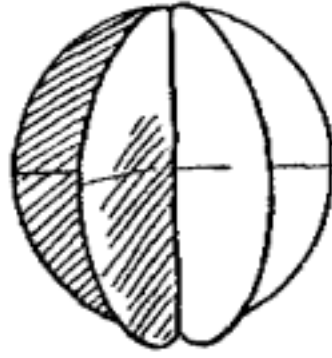

FIG. 85

While some may succeed in disuniting the three papers, they will find that it is not a simple matter to fix the ball together again. As a toy it will afford great amusement to children by placing the ball on the table, so that they may blow it about--a very little puff being necessary to send the ball rolling along. It can also be used as a shuttlecock, and is capable of withstanding tossing up and down with the hand or a bat without losing its original form. An interesting game for several players can also be arranged if several balls are made, each played being given a ball and a small tube or pipe stem. The balls are placed in a row at one end of the table, and at a given signal the players force their balls along by blowing through the tubes. The object of the game is to see whose ball will arrive first at the opposite end of the table, and the contest will be found both exciting and interesting.

[Next](#) | [Previous](#) | [Contents](#)

Paper Magic

Will Blyth

[Next](#) | [Previous](#) | [Contents](#)

Windmill

Here is a very simple, yet practical and sporting outdoor toy for children. Take a piece of paper about four inches square and make four cuts from corners to centre as shown by the dotted lines in Fig. 86.

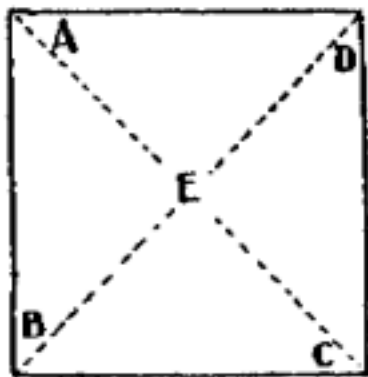

FIG. 86

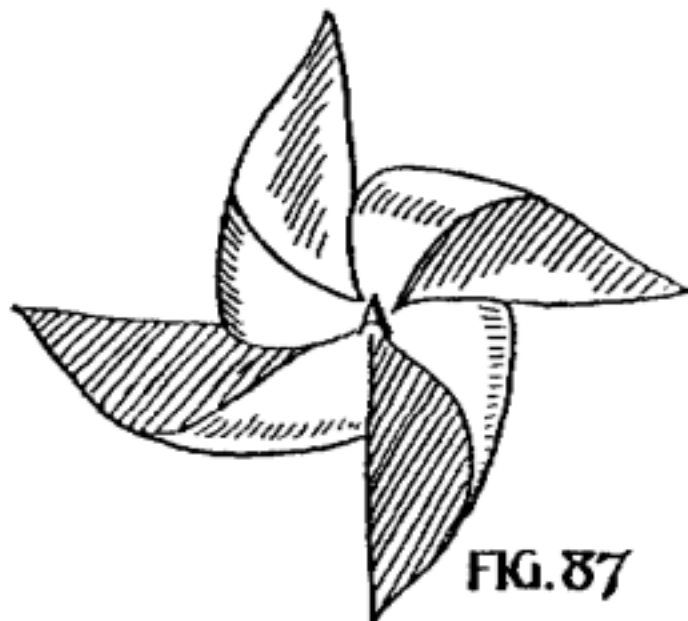

FIG. 87

Now take the corners of Fig 86, lettered A, B, C, and D, and bring them alternately over to the centre E, when Fig. 87 will be formed. All that is now required is to fix a pin through the centre point A, of Fig 87 to the top of a short stick, and the windmill is made. If held in an horizontal position while running along the road, the paper windmill will revolve very rapidly causing quite a pretty effect.

[Next](#) | [Previous](#) | [Contents](#)

Paper Magic

Will Blyth

[Next](#) | [Previous](#) | [Contents](#)

Puzzle Box

Here is a fold that is not at all difficult, and, when finished, forms an interesting little puzzle. The size of paper used will, of course, depend upon the capacity of the box, but a sheet of writing paper about eight inches square is a convenient size. First fold the paper as instructed in Figs. 24, 25 and 26 (Pin Tray). Then re-open the paper and fold again so that the new folds cross the others, making the paper, when opened out, appear like Fig. 88.

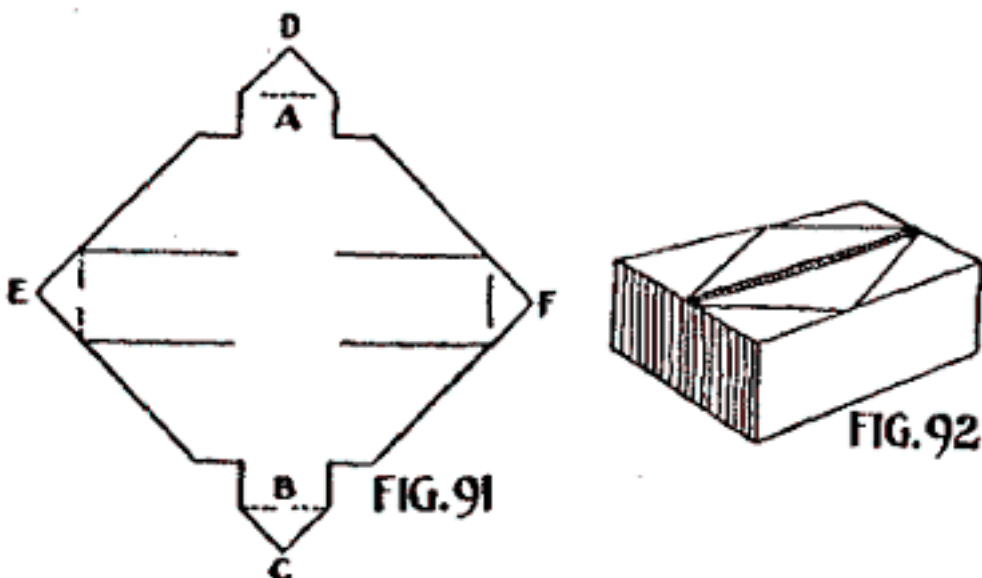
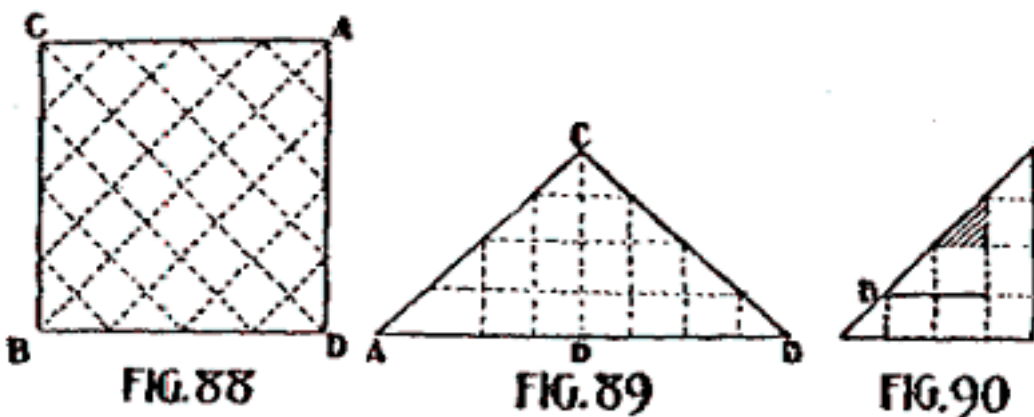

Turn point A, of Fig. 88 down to point B, making a triangle similar to Fig. 89. Next fold point A, of Fig. 89 over to point B, folding along the dotted line C, D, and the paper forms a four-folded triangle like Fig. 90. Now cut away the shaded little triangle A, of Fig. 90, cutting right through the four papers also make a cut through the four papers along the solid line B, of Fig. 90 and the paper When opened out will be similar to Fig. 91.

Finally make a centre cut in the tabs D, and F, of Fig. 91 as shown by the dotted lines marked A, but be careful not to carry this cut to the edge on either side; also make half-way cuts on either side of the remaining tabs C, and E, cutting along the dotted lines marked B. All that now remains to be done is to bring the end C, over to D, folding lightly the sides of C, so that the end of C slips into the centre slip A, of D, this accomplished, the sides of C, are opened out as before. The end of E, is now fitted into F, in a similar manner, the completed box now appearing as Fig. 92. The puzzle is, for those unacquainted with the method of fixing the box together, to open it without tearing the paper, and simple though the secret is, it is not always discovered, and the article will be found a means of interest and amusement to many.

[Next](#) | [Previous](#) | [Contents](#)

Paper Magic

Will Blyth

[Next](#) | [Previous](#) | [Contents](#)

The Flapper

This ingenious mechanical fold is said to have been introduced into this country by the Japanese; whether this is true or not, it certainly is a very cleverly thoughtout construction and quite worthy of that clever race. Take a sheet of paper about eight inches square and well press the folds into the paper as shown by the dotted lines of Fig. 37 (Kettle). Now fold each corner alternately over to the centre diagonal line as indicated in Fig. 93, and well press the fold from the corner (at the full width of the paper) to the centre line, i.e. as from A, to B, of Fig. 93. Each corner will be found capable of being folded two ways as in Figs. 93 and 94.

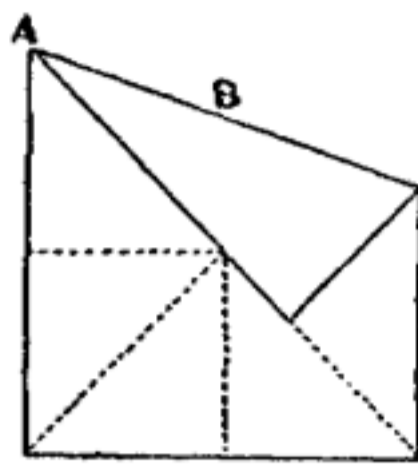
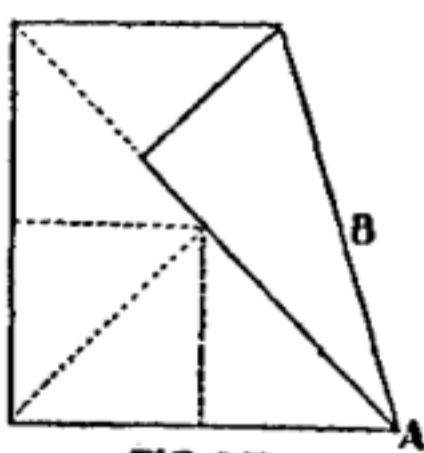

After each corner has been thus folded, the paper will appear like Fig. 95 when opened out. Next fold the paper in half along the dotted line, A, A, shown in Fig. 95, and press the ends B, B, and C, C, inwards, which will give Fig. 96.

Take the corners A, A, of Fig. 96 and press to the centre, bringing the top parts B, B, together inside the folded paper. This operation will give Fig. 97.

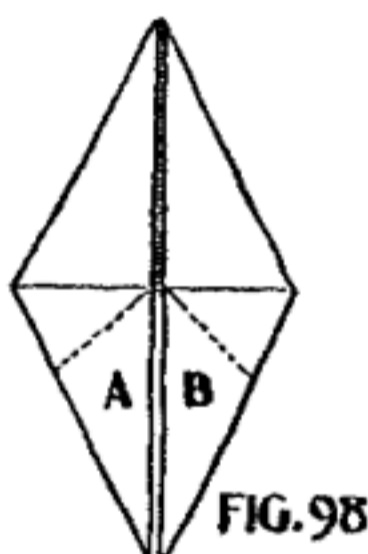
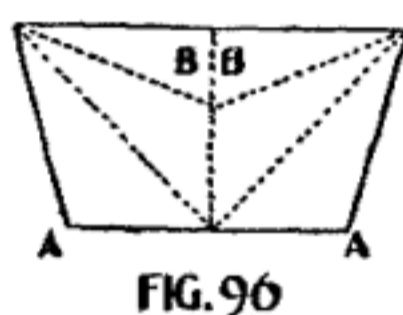
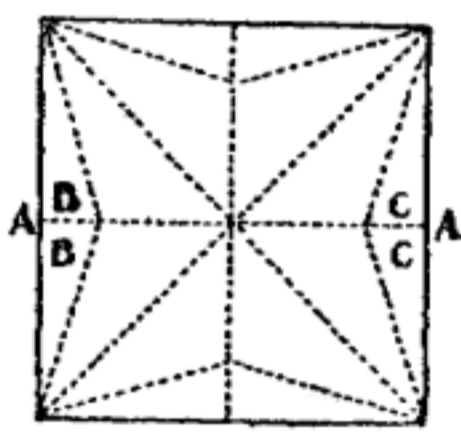

Now fold the point A, of Fig. 97 downwards, bending along the dotted line C, C, and treating the opposite point B, in a like manner, making the fold now appear as Fig. 98.

The bottom point A, of Fig. 98 is now turned to the back of the fold, by bending along the dotted line shown, and B, is similarly folded to the front, giving the appearance of Fig. 99.

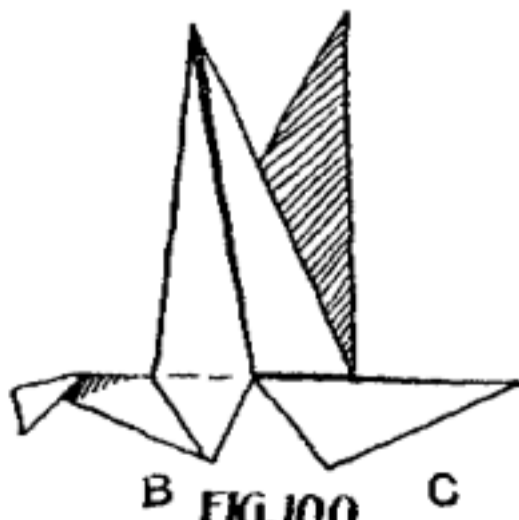
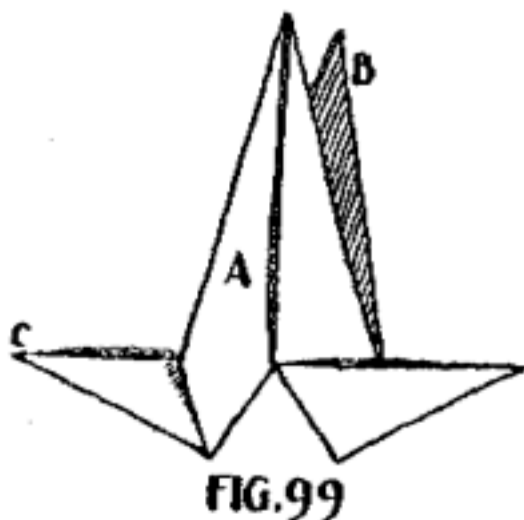

Slightly bend the wings A, and B, of Fig. 99 outwards and fold over the end C, in order to make a head for the flapper, when the bird is complete as Fig. 100.

It will now flap its wings in a most lifelike manner, if held between the thumb and forefinger of each hand, by the points B, and C, of Fig. 100, and the end C moved slightly upwards and downwards.

[Next](#) | [Previous](#) | [Contents](#)

Paper Magic

Will Blyth

[Next](#) | [Previous](#) | [Contents](#)

Smoke Ring Box

The very pretty effective smoke rings that a smoker sometimes emits from his mouth can also be made to come from a box made of paper. Six pieces of stout writing paper about three inches by four will be required.

Turn up an inch of the top and bottom ends of each piece as shown by the dotted lines of Fig. 101.

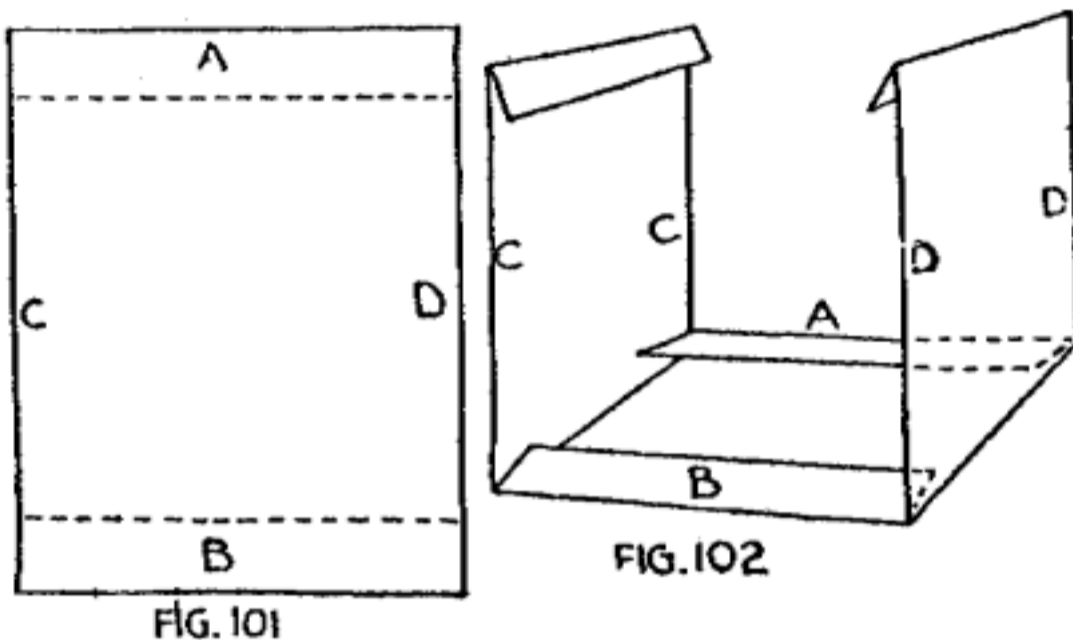

Lay one piece flat upon the table with the ends B, of Fig. 101 upwards, and then slip the ends of two X of the other pieces under C, and D, forming Fig. 102. Now fix up two more pieces to form the other sides of the box, making the plain edges pass inside A, and B, of Fig. 102 and the turned-up ends overlap the plain edges C, and D of Fig. 102, which will give Fig. 103.

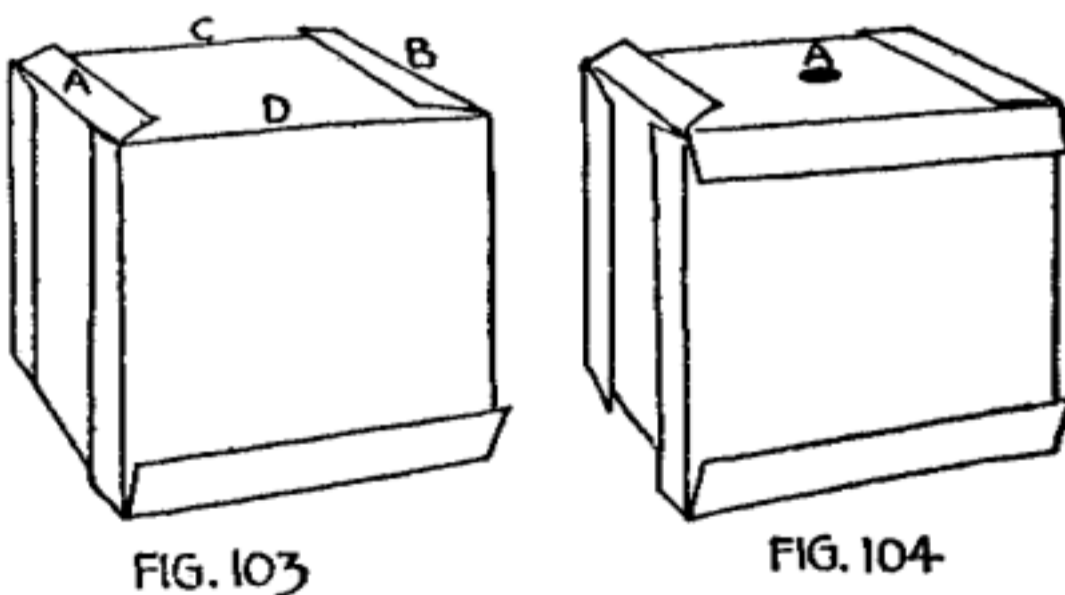

Cut a small hole in the centre of the remaining piece of paper and fix it in the top of Fig. 103, passing the plain edges under A, and B, and making the turned up edges overlap the edges C, and D, when the box is complete as Fig. 104. If smoke is now passed from the mouth into the small hole A of Fig. 104 and the bottom of the box tapped with the forefinger, a series of smoke rings will ascend from the box forming a very pretty and effective display.

[Next](#) | [Previous](#) | [Contents](#)

Paper Magic

Will Blyth

[Next](#) | [Previous](#) | [Contents](#)

Part II Paper Conjuring

Introduction

There have been hundreds of books written on magic, dealing with almost every possible phase of the art, many of them specialising in one particular branch, such as Coins, Billiard Balls, Figures, Thought Reading, Cards, Handkerchiefs, etc., etc., but until the advent of the present volume, no one book has been published setting forth a series of tricks from which an entire entertainment can be given with an ordinary newspaper.

In bygone days the status of a magician was judged mainly by the quantity of apparatus he carried, and the number of large mechanical pieces he was able to exhibit to the public, but of late years the trend has been more towards what is now known as the "attache case" order of conjuring, and it is believed that there will be a great demand for such a work as this which seeks to instruct the amateur conjurer and drawing-room entertainer how to amuse and interest an audience for one to two hours, simply by means of paper. It must not, however, be supposed that although the method and- material employed are simple, little or no preparation will be required; on the other hand, it is often the case that the less involved the trick, the greater is the amount of showmanship required to present it in an entertaining and interesting manner. Each item given in this section should, therefore, be carefully rehearsed before a looking glass again and again, until the hands, eyes and patter harmonise completely one with the other.

It is also most important when showing to lead the audience to believe that something more wonderful is being done than is actually the case. It is a great mistake to say, as do some performers, "there is really nothing in the trick, you simply roll the paper, tear it so, and the thing is done." The audience like to be mystified and have come for that purpose, and that being the case, it is the duty of the performer to give them what they want. The less the audience understand of the modus operandi the more will they enjoy the presentation, and the greater will be their estimation of the entertainer. Thus, in the working of the tree explained further, although the trick is absurdly simple and consists in merely rolling up the paper and tearing or cutting it, yet the effect on the audience when the tree is pulled out is so great, that they generally attribute to the performer greater powers than he really possesses. In this trick, and, indeed, in most of the others, an added effect can be obtained by the touch of the magic wand "to complete the process," and yet this little camouflage, silly though it may seem to some, provides the proverbial "red herring" and misdirects the minds of the spectators into puzzling out a magical reason for the creation.

The patter, or verbal accompaniment to the tricks, must be well rehearsed. It is important that there should be no expressionless repetition of a lot of words rattled off in a parrot-like manner. Talk naturally and easily, and do not force too many jokes at one time. Each trick in the book has the patter attached, as used by the author when entertaining. This, however, is given merely as a guide; the actual wording should be adapted to suit the individual characteristics of the performer. Every endeavour should be made to secure originality in effect, presentation, patter, and, even in the trick itself, where perhaps some little improvement may suggest itself to the performer. Many of the tricks given in this book are known in other forms, but they have all been more or less added to by the author, so that in most cases the original trick or principle is quite obscured.

At the close of the entertainment it will be found that if the made-up articles are offered to the audience there will be a keen desire to possess these souvenirs, especially in the case of children. As the distribution does not involve the disclosure of any well preserved secret, this pleasing little finale should never be omitted. I usually offer them to those who have in any way assisted me during the performance, and it is surprising how children will treasure the most ordinarily torn piece of paper, possibly surrounding it with a halo because it has been "used by the conjurer."

Lastly, I might point out that there is a vast gulf between learning the secret of tricks and in the performance of them, so that the secrets are not exposed to the audience; and further, so that the audience are entertained by the presentation. The performer must acquire the characteristics of the art of showmanship--and they are many. Some have already been dealt with, but the most important to my mind is a cheerful disposition. A smile at the beginning--a smile in the middle--and a smile at the end. In short carry a smile right through. No matter if something goes wrong--smile it away.

"It's easy enough to look pleasant
When the show goes along like a song,
But the magician worth while
Is the one who will smile
When one of his tricks goes wrong."

WILL BLYTH.

[Next](#) | [Previous](#) | [Contents](#)

Paper Magic

Will Blyth

[Next](#) | [Previous](#) | [Contents](#)

Part II Paper Conjuring

Two Blacksmiths

Two sheets of coloured paper, one red and one blue, are each rolled into balls, and after being wrapped in separate papers are placed in two tumblers, the red ball in one tumbler and the blue ball in the other. The performer now touches each tumbler with his wand, and upon opening the papers the balls are seen to have changed places.

Working--First Method

Two sheets of newspaper are pasted together round the edges, a piece of blue paper being laid between the two sheets before pasting them together. Two more sheets of newspaper are prepared in the same manner, but with a red piece of paper between them. Fig. 105 will perhaps indicate this more clearly.

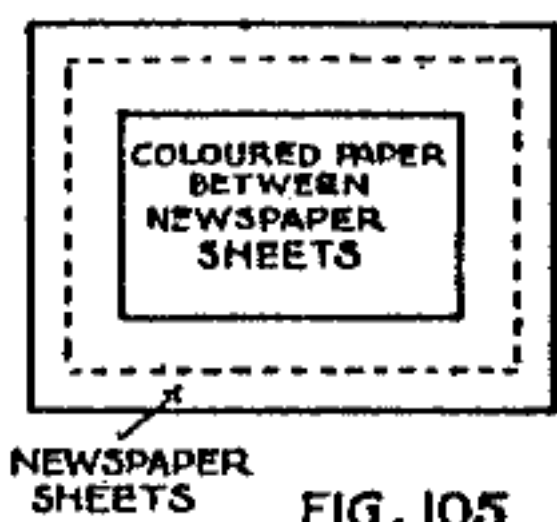

These prepared papers are given a private mark, so that they may be easily distinguished. At the commencement of the trick the two prepared sheets, together with a red and a blue sheet of paper, are lying upon the performer's table. The four sheets are shown, and the coloured sheets rolled

into a red and a blue ball. The red ball is wrapped in the paper containing the concealed blue piece of paper, and the blue ball is wrapped in the paper containing the concealed red piece of paper. They are laid upon the table and the tumblers introduced. In doing this the two papers are purposely mixed in order to puzzle the audience as to which paper contains the red or the blue ball. They are now placed in the separate tumblers but in order to demonstrate clearly to the audience which paper contains the red ball and which paper contains the blue ball, the bottom of each paper is torn slightly, exposing the concealed colour, which is, of course, taken by the audience to be the colour of the ball placed there by performer. The wand is then requisitioned and the packages opened, disclosing the fact that the two balls have changed places.

Working--Second Method

This method, in which sleight of hand only is employed, is one that will assuredly appeal to those who delight in mysterious effect tar excellence. Two unprepared paper bags are required; a sheet of blue and a sheet of red paper, also a duplicate sheet of blue paper rolled into a ball. The two bags are opened and stood upon the table and the duplicate ball of blue paper is, unknown to the audience, placed behind one of the bags. The position at the commencement of the trick is indicated in Fig. 106.

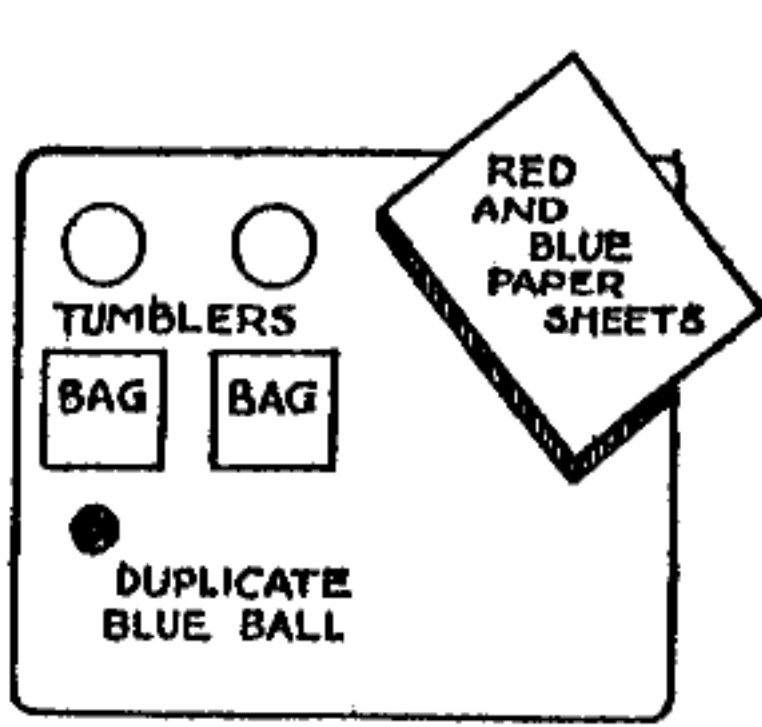

The sheets of red and blue paper are rolled into separate balls and laid upon the table. The hands are shown to be quite empty, and the bags held out one at a time for inspection.

The bag with the duplicate ball behind it is shown last, and in lifting up the bag with the left hand, the right hand is placed flat upon the table, picking up the concealed ball, which is now held concealed in the right hand. This is an easy matter if worked from the side of the table, with the left side of performer to audience. The red ball is then picked up with the right hand and presumably placed in one of the bags, but in reality it is retained in the right hand, and the concealed blue ball placed in the bag instead. This move is repeated with the blue ball, resulting in the red ball being placed in the other bag, leaving the blue ball concealed in the hand. The wand is now taken up in the right hand, thus making the retention of the ball in the hand an easy matter until opportunity arises for its disposal.

Working--Third Method

This is a very ingenious method of working the trick, and is well suited to beginners in magic, involving the use of two prepared bags. Four bags are really necessary, two of which have about an inch cut A the top. A red paper ball is dropped into one of the longer bags, and one of the shorter bags fitted inside, the tops of the two bags being pasted together, so that when the bag is opened, it appears to be one bag only. The remaining two bags are similarly prepared with a blue ball in the bottom, a private mark being made to indicate to performer which bag contains the red or the blue ball.

The bags as prepared are shown in Fig. 107. When placing the balls in the bags the positions of the respective colours should be duly emphasised so that the audience are under no misapprehension as to which bag contains the red ball and which bag contains the blue ball. The bags are then closed and placed, one in each

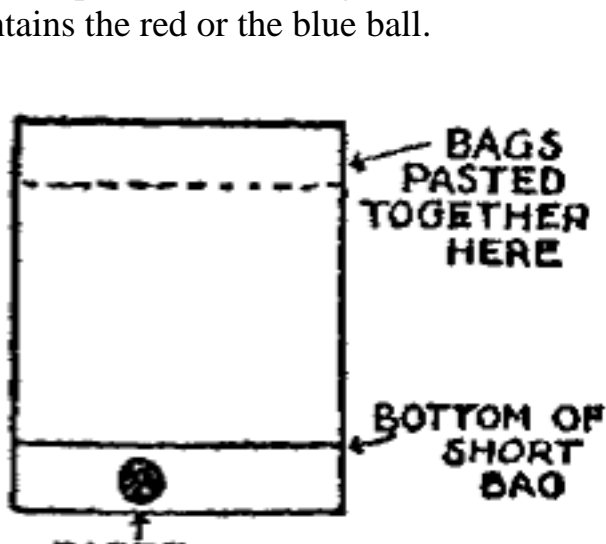

tumbler, the procedure of discovering and changing the balls being the same as with the two previous methods.

Patter

Ladies and Gentlemen. I shall have much pleasure in relating to you a short magical story, entitled, "The Two Blacksmiths." This sheet of red paper, which I roll into a ball, will represent one of the smiths and this sheet of blue paper, which I also roll into a ball, will represent the other. They each had separate workshops, which were exactly opposite each other, and as each shop was well provided with glass windows, it will not be out of place if I make use of these two tumblers for the two workshops. You are welcome to examine them if you wish, but I think you can easily see the inside from the outside, and, if you were to get inside, you could just as easily see the outside from the inside. Now the smiths are about to commence business and therefore get into working attire. These sheets of paper (or "bags," whichever is being made use of by performer) will serve for the purpose. Now they are both inside their shops, working away with a bang and a clang. A gentleman, whose house stood not far from the two smiths, finding that the noise was too much for his nerves, visited the smiths and offered them ten pounds each if they would move to another shop. Here is the gentleman, my wand, visiting the first shop. Let me see, who is here? Ah the red smith, and here, of course, in the second shop is the blue smith. They accepted the gentleman's offer, and, incidentally his ten pounds, and, in about a week's time he visited one of the smiths and enquired whether they would be moving soon according to agreement. "We have already done so," answered the smith. "I have moved to Jack's shop and Jack has moved to mine." And here you see it is just as he stated, first the red smith, and now the blue. the only question is: however did they manage it?

[Next](#) | [Previous](#) | [Contents](#)

Paper Magic

Will Blyth

[Next](#) | [Previous](#) | [Contents](#)

Part II Paper Conjuring

Two Little Dicky Birds

This little elementary magical sleight is so old that it is almost forgotten by the present generation. but in bygone years it afforded great amusement to children. It is a most simple trick, yet to many at first sight the secret is not always apparent and may often be shown with advantage.

Effect

The two forefingers are extended and a small piece of paper stuck on the end of each. The papers are then made to disappear one at a time by simply raising the fingers, and are made to return again by the same method.

WORKING

Moisten two small pieces of paper and stick one on the end of each forefinger. Tap the two forefingers on the table (the rest of the hand being closed) while repeating the patter verse. To make the paper disappear the right forefinger is first raised in the air and quickly enclosed in the hand, the second finger being brought to the table in its place. The spectators regard it as the same finger as before, minus the paper. After both pieces of paper have been made to disappear, they are made to appear again by the same process.

Patter

Two little dicky birds
Sat upon a wall,
One named Peter
The other named Paul.
Fly away Peter (Disappear right hand paper),
Fly away Paul (Disappear left hand piece);
Come back Peter (Right hand piece returns),
Come back Paul (Left hand piece returns).

[Next](#) | [Previous](#) | [Contents](#)

Paper Magic

Will Blyth

[Next](#) | [Previous](#) | [Contents](#)

Four Boy Scouts

Effect

A table knife and four small pieces of paper are handed for examination. The papers are moistened and stuck separately, two on each side of the blade. Two pieces of paper are removed, leaving one piece on each side of the blade. The remaining pieces are then removed and the knife shown clean. The four papers are mysteriously made to return to the knife.

Working

The real secret of the trick is the manner of holding the knife by the fingers when showing that the pieces of paper have been removed, or replaced, as the case may be. Two pieces of paper are first stuck on each side of the blade of the knife, the handle of which is held in the right hand as shown in Fig. 108.

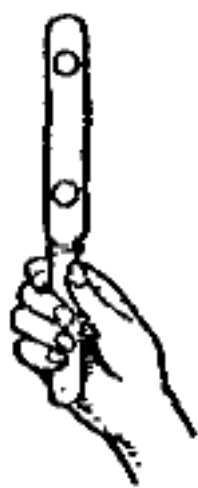

FIG. 108



FIG. 109

One piece of paper is apparently removed from each side with the thumb and forefinger of the left hand, but in reality only one piece (the top piece) is taken away. The knife is apparently half-turned to show the under side of the blade, but it is actually turned completely round, the handle being twisted with the fingers, and the same side exhibited with only one piece of paper showing as Fig. 109 two pieces remaining on the under side of the blade. The papers at the end of the blade are then apparently removed as before, and the blade shown clean. When it is desired to show that the papers have returned, the knife is given one half-turn to show the papers on one side, and a complete turn "to show the two papers on the other side," the same side of course, being shown each time.

Patter

Ladies and Gentlemen. A splendid and popular institution for boys is the organization known as the Boy Scouts, and I am about to demonstrate to you how smart they can be in their movements. This knife represents the scout headquarters, and these four small pieces of paper four smart little scouts. They come to the headquarters and wait for orders with their bicycles; here they are two on each side. Two are sent away on a message and are told to be back sharp at eight o'clock. Here you see the vacant space this side, and here is the vacant space on the other side. The others are also sent away and told to be back by eight o'clock. Thus, you see Headquarters empty on this side, and on this.... It is now just on the stroke of eight o'clock, but they have not returned. Yes, here they come, like true British boy scouts, two on one side and two on the other,

Four jolly boy scouts
Who went for a ride,
Returned at the tick of eight
Just two on each side.

[Next](#) | [Previous](#) | [Contents](#)

Paper Magic

Will Blyth

[Next](#) | [Previous](#) | [Contents](#)

Paper Bag Cookery

This and the following trick of "Indian Ribbons" will prove a useful addition to the conjurer's repertoire, as it affords a use for the mass of coloured paper ribbon which is produced from time to time in the hat production or tambourine tricks. At the same time, both will be found easy and effective tricks.

Effect

A Sheet of newspaper is twisted in the form of a cone and initialled by a member of the audience. It is then filled with coloured paper ribbon from a box. The initials are shown to prove that the original paper has not been changed, and the cone is closed at the top. A pass is made over it with the magic wand, and upon breaking the cone open the paper ribbon is found to have changed into sweets, which are handed round to the audience.

Working

On the table is a box containing a closed newspaper cone filled with sweets, on top of which is a quantity of coloured paper ribbon. A sheet of newspaper is shown, and a paper cone made from it (slightly larger than the concealed one in the box) (Fig. 110).



FIG. 110



FIG. 111

The paper ribbon is held up to view, returned, and a pretence made of filling the cone with paper ribbon from the box. The cone is scooped down into the box, presumably for the purpose of getting the ribbon inside, but in reality the concealed cone filled with sweets is loaded into the empty cone (Fig. 111) a small quantity of paper ribbon being placed on top. It is then closed and the initials identified. The performer holds the cone over a plate, breaks off the bottom portion of the cone, allowing the sweets to fall in a shower on the plate. These are now handed round for consumption, greatly to the delight of the juvenile members of the company.

Patter

Ladies and Gentlemen. Some years ago a celebrated chef named Soyer popularised a form of cookery by means of paper bags. These may have produced well-cooked dishes, but they only produced what were originally placed inside. I have now to show you a little improvement upon that gentleman's invention. First, however, we require a paper bag. Easily made as you see, from this piece of newspaper. Will you kindly initial the bag, madam, so that there will be no mistake as to its identity. Have you a pencil? Thank you. of course, you are no doubt aware of that charming couplet by the late Dan Leno,

"You can drive a horse to the water,
But a pencil must be 'lead.'"

Here is a box full of coloured paper ribbon, and I will now fill the bag to the top with them and show you how to improve upon Mr. Soyer, by producing a cooked article quite different from that which was placed inside. I press down the ribbon into the bag and close over the top. Please, look at the bag, madam, to see whether your initials are still there. Thank you. Now a touch of my magic wand and our cookery is done. I open the oven door, and here you see are the cooked articles, which I will now pass round in order that those who wish, may sample the paper bag cookery.

[Next](#) | [Previous](#) | [Contents](#)

Paper Magic

Will Blyth

[Next](#) | [Previous](#) | [Contents](#)

Ribbons of India

The effect of this trick is similar to the old Indian Sand Trick where several coloured sands are mixed in water, the performer producing in dry form any colour called for. Though mysterious, it always appears to be a somewhat "messy" performance, and, to those to whom the older trick appeals, the present effect will be found cleaner and easier to work. As in the case of the previous trick (Paper Bag Cookery), the waste product from the hat or tambourine tricks may be utilised.

Effect

Four saucers are exhibited, each containing a different coloured paper ribbon. A box is shown to be quite empty, and the paper ribbons emptied into it and well mixed together. Performer now asks for a certain colour to be named, and putting his hand into the box he fills each saucer with the colours as named.

Working

The box is quite free from preparation, but on each saucer, underneath the paper ribbon, is a small parcel of the same coloured ribbon. Each of these parcels consists of a quantity of one colour ribbon tightly pressed together, over which is pasted a piece of tissue paper of the same colour as the ribbon inside.

The parcels lie unnoticed among the paper ribbon in each saucer, being of the same colour. The best plan is to lay the parcel in the saucer and then cover it with some loose paper ribbon, which if pressed down will hold together fairly well. On top of this some more loose ribbon is laid, and in presenting the trick this can be safely lifted up for display, without fear of exposing the concealed parcel. When the ribbon is emptied from the saucers into the box, the parcels fall to the bottom of the box and remain there until required. On a certain colour being called it is an easy matter to select that coloured parcel, the ribbon being produced by rubbing the parcel between the hands which bursts the tissue paper and the latter falls with the ribbon into the saucer, unnoticed by the audience.

Patter

Ladies and Gentlemen. As I am supposed to be a "sorcerer" you will not be surprised at my using these four articles. Of course, I must be careful not to drop them or it will mean the break-up of China, and I shall then have to commence "Pekin" up the pieces. Please notice that each saucer contains paper ribbon of a different colour. This is red--like the blush of a negress. Here we have some white, exactly the colour of a young man after his first cigar. The ribbon in this saucer was originally white, but I "blue" it this colour. Lastly, we have this nice colour, canary yellow. It is rather a loud colour, so much so that you can almost hear the bird singing. Reminds me also of a friend of mine who thought that he could sing--it is a "yeller." I am now going to use this box as a mixing machine. Please examine it very carefully to assure yourselves that there are no secret entrances or exits. I will now empty the paper ribbon into the box and mix all well together with my hands. Here is the ribbon you see, all hopelessly intermingled. Would someone please name one of the colours. Red, white, blue or yellow, and I will endeavour to separate some for you and fill the saucers as before. White, did I hear? Notice, please, that my hands are quite empty. I put them in the box, rapidly select the white pieces, and here they are in the saucer. Another colour please. Yellow. Thank you. Here is the yellow ribbon. Would you, madam, please select one of the remaining two colours, blue or red. You see I always like my tricks to be select. Red, madam? Here it comes from my hands, blushing furiously. There now only remains the blue ribbon. Again I show you that my hands are quite empty, place them inside the box and here is the blue ribbon, so that now you all know exactly how it is done.

[Next](#) | [Previous](#) | [Contents](#)

Paper Magic

Will Blyth

[Next](#) | [Previous](#) | [Contents](#)

Magic Purse

Effect

A coin is enclosed in a folded piece of paper and the paper waved in the air. When the paper is unfolded, the coin is found to have mysteriously disappeared. The paper is refolded again, waved in the air, and upon being re-opened the coin is found to have returned.

Working

Take two pieces of paper about six inches square and make two creases horizontally and perpendicularly, dividing the papers each way into three equal divisions as indicated by the dotted lines in Fig. 112.

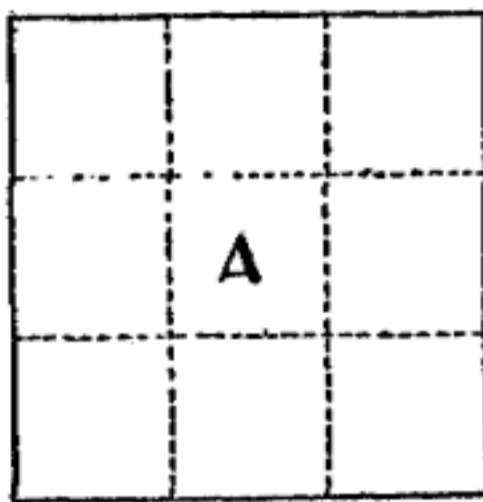

FIG. 112

Next paste over the centre square A of Fig. 112 and place both sheets together, taking care that only the centre squares of both sheets adhere, leaving the surrounding squares free. It will now be found that the folds can be turned down on both sides and two separate packets formed. If the folding has been neatly done, it will only appear to the uninitiated as one packet. One side is opened out, and the paper is lying upon the table at the commencement of the trick. Performer exhibits prepared sheet of paper as ordinary sheet and wraps a coin within the folds. A waving motion is made in the air, affording an opportunity for the paper to be brought down reversed, when it is opened, and the coin shown to have disappeared. The paper is refolded, and finally the coin is found to have returned to the paper.

Patter

Ladies and Gentlemen. In bygone days, before the advent of trains and Parish Councils, several of our main roads were infested with highwaymen who made travelling a risky proceeding, especially if one carried much cash about with him. Some people adopted peculiar methods of concealing their wealth from the hands of "him what took what isn't is'n," but I will now show you a very easy way out of the difficulty. All that you require is a magic purse, and that can easily be made from this sheet of paper. Will someone in the audience kindly lend me a coin to represent the wealth I am to carry on my journey. Thank you, sir! I will now place your two shillings in the purse. Beg pardon, sir, what did you say? Oh, you lent me half a crown? Well, surely you don't want to spoil the trick for the sake of sixpence. Well, sir, I take your half-a-crown and place it in the purse, and by folding the four edges to the centre I have the money safely enclosed within the magic purse, There it will remain, visible, or invisible, just as I desire. Now I am travelling along the road, and, to the cry of "Stop! your money or your life!" I hand over my purse saying, "I am afraid, my dear Mr. Highwayman, you will find it is empty." He opens the purse, so, and finds that there is really nothing inside. I am allowed to proceed, and upon arriving at the next town I take my purse out to pay for supper and, of course, desire the money to be visible, and here you see it is, in its beautiful solidity. I now return it to you, sir, with many thanks, and am very glad for your sake that I was able to prevent the highwayman from taking possession of it.

[Next](#) | [Previous](#) | [Contents](#)

Paper Magic

Will Blyth

[Next](#) | [Previous](#) | [Contents](#)

Ball of Mahomet

This weird and mysterious trick has the double advantage of being little known and easy to perform. After a little introductory patter, it is suggested that an effective pianoforte selection should accompany the moves, so that the whole attention of the audience is directed to the movements of the ball.

Effect

A piece of tissue paper is rolled into a ball and thrown to the ground. At the performer's word of command the paper ball slowly rises from the ground and remains suspended in the air. The magic wand is passed above and below the ball "to prove the absence of any support."

Working

The secret depends principally upon a length of fine black thread, the exact size being regulated according to the height of performer. One end of the thread is fastened by a pellet of wax to the back of performer's hair, the other end being similarly attached to the lowest button of his vest. A small sheet of tissue paper is freely exhibited and, whilst being held out for examination with the left hand, the right hand secures the lower end of the thread from the vest button. A chair is now moved slightly to one side of the platform, thus giving the performer an opportunity of fixing the end of the silk thread to the front of the chair-back. This is not noticeable, even at a short distance, and the thread will be found capable of sustaining a greater strain than if fixed to the back of the chair-back. By carefully moving backwards the thread is drawn fairly taut and the sheet of paper is formed into a ball around the thread, which is now allowed to slacken, the ball being thrown on the floor. Various passes are now made with the wand, and, by raising or lowering the head, the ball can be made to rise or fall as desired, thus providing excellent opportunities for a really effective display. The importance of perfect showmanship throughout the whole of the presentation, however, cannot be too greatly emphasised. The wand is now passed underneath and over the ball, care being taken that it does not come into contact with the thread. Some performers keep a small hoop around their necks which is passed over the ball, but this effect is far more difficult to work successfully than the wand. The ball is finally allowed to drop to the floor. It is then picked up, the paper ball opened out and passed for examination.

There is another method of performing this trick which is more suited to the stage. The black silk thread in this case stretches right across the floor of the stage and is held by two assistants, or, if only one assistant is desirable, one end of the thread may be fastened about three or four feet from the ground to one side of the stage. The thread lies along the floor until wanted, and this of course allows the performer perfect freedom of movement both before and during presentation. The sheet of tissue paper is shown, the performer taking care to stand behind the thread on the floor. The assistant then raises the thread to the required height, and the ball is made around the thread as before. Several additional effects, however, are possible in the stage version of the trick, which if well worked create a really first-rate illusion. For instance, the ball may be allowed to descend slowly to the floor and a chair placed over it, the chair rungs being to the front and back of the thread. The rising and falling of the ball may still be effected, being only limited by the height of the chair seat. This little manoeuvre effectually removes from the minds of the audience any idea that the movements of the ball are actuated by a thread from above. The ball may also be placed on a plate which is held by the performer with both hands, and at the word of command the ball jumps off the plate to the floor. A further good effect is obtained by standing a plank of wood in a slanting position against the table and, at the performer's call, the ball travels slowly up the plank and on to the table. Finally the ball is ordered to jump into the performer's hand, when it can be opened out as before, or the thread may be pulled sharply by the assistant, broken, and pulled free of the ball, which is then handed out for examination.

Patter

Ladies and Gentlemen. Some of you may have beard the story of Mahomet's coffin, which is said to remain for all time in mid air, without any visible means of support. To some this may seem to be incredible, but I propose to demonstrate here this evening, by means of this piece of paper, that there may, after all, be a certain amount of truth in the story. I will just roll the paper into a ball and place it on the floor. Now, if our pianist will kindly oblige with a little mahomety music, we may be able to induce the ball to show us its possibilities....

I think that the ball has now proved the case successfully and justified its title, so I now command it to jump into my hands to be demobilised. Thus you see, obedient to the last, it obeys my bidding and I shall feel obliged if you will please examine it to see that there is no internal mechanism to account for the phenomenon.

[Next](#) | [Previous](#) | [Contents](#)

Paper Magic

Will Blyth

[Next](#) | [Previous](#) | [Contents](#)

Separating the Services

Effect

Three small sheets of paper are handed to a member of the audience, who is requested to tear them across. The torn pieces are then distributed to the company, and they are asked to write down names of well-known admirals and generals, one on each slip of paper. The slips are then collected in a borrowed hat, when performer takes from the hat a slip, containing name of admiral or general, as desired by the audience, until the whole of the slips have been selected.

Working

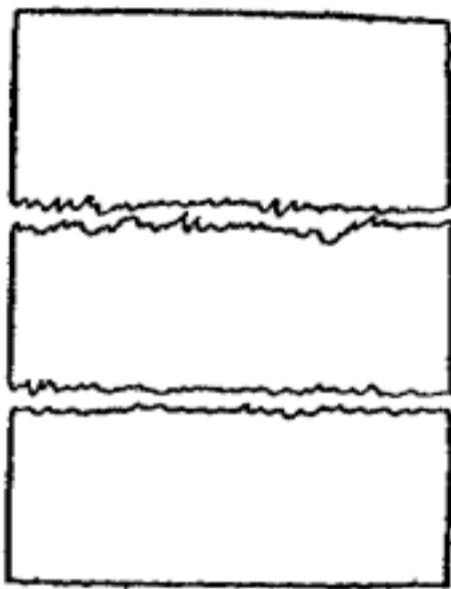

FIG. 112A.

Three sheets of notepaper are handed to a volunteer assistant, who is asked to tear them across twice (performer guiding him, so that the paper is torn as shown in Fig. 112A).

Thus there are nine slips: three with rough edges top and bottom, and six with one smooth edge and one rough edge. The three rough-edged slips are now handed out to the audience, who are requested to write the name of a noted admiral upon each slip. Three of the remaining slips are then handed

out (either the top or bottom slips will do) and written with the names of generals. The slips are collected in a hat, and it is an easy matter for performer to select either an admiral or a general, as requested by the audience, simply by feeling the edges of the slips. (Note.--The "R" mnemonic may be employed here, the Rough edged slips being used for the Army, i.e. Red).

Patter

Ladies and Gentlemen. We have reason to be grateful to our Army and Navy for their work on land and sea. I will show you a trick in which both services take equal part. That being so there is no doubt, of course, as to the success of the experiment. I shall make use of pure white paper and require the services of a gentleman with an unblemished character to act as my assistant. Thank you, sir. Please take these three pieces of paper and submit them to your closest scrutiny. Now will you kindly tear the papers across twice, so. Very neatly done, sir. Now I want some members of the audience to each write down the name of a well-known admiral; after the names have been written, if someone will kindly lend my assistant a hat, he will collect the slips in it and keep them safely in his possession for a time. I will now hand out three. more slips, and this time should like to have the names of well known generals written on the slips. Now will you please return them to my assistant, and he will mix the whole of the papers well together. Now I am going to endeavour to separate the Services by picking out either an admiral or a general as you desire. Will anyone call for either an admiral or a general. Thank you, madam. A general, I think you said. Here he is. An admiral, here to the front, sir. Of course, you would not expect the British Navy to be behind, would you? Another please.... The two Services have now been duly separated as you see.

[Next](#) | [Previous](#) | [Contents](#)

Paper Magic

Will Blyth

[Next](#) | [Previous](#) | [Contents](#)

An Episode of Mere Man

Effect

The performer enters with three paper rings over his arm. These are freely shown to the audience, being apparently identical in every way, and are each cut down the centre lengthwise. The resultant rings, however, to the astonishment of the beholders, are seen to be quite different. The first ring is separated into two halves, half as wide but the same length as the original ring. The second ring, however, on being cut forms one continuous band, half as wide, but twice as long as the original. The third ring, like the first, is separated into two halves, but what is most extraordinary, they are seen to be linked together like a chain, and one would have to be broken in order to separate them.

Working

It has been stated that we are indebted to some old Indian fakirs for this neat and puzzling little drawing-room trick. The secret is extremely simple, and depends entirely upon the method of making up the bands. These may be prepared beforehand, but a much better effect will be produced if the straight strips are first handed for examination and the bands then joined in front of the audience, care being taken that they do not detect the secret during the process.

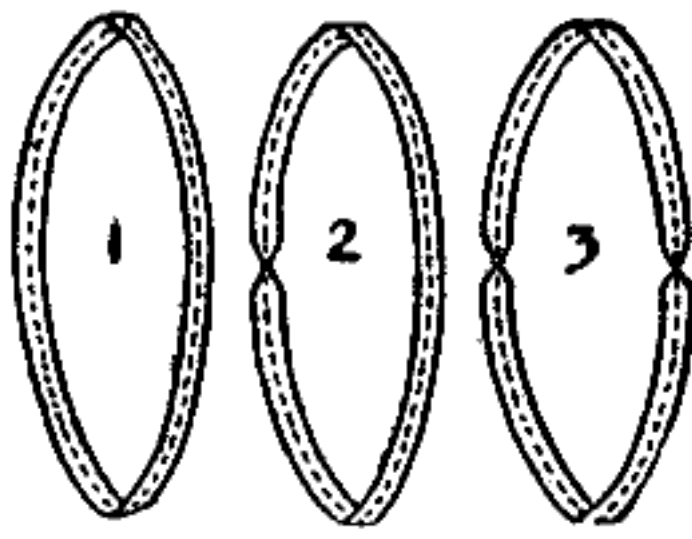

FIG. 113

Tear three long strips of paper, each about one inch wide, to make rings No. 1, 2, and 3 of Fig. 113.

The ends of ring No. 1 are joined together in the ordinary way by means of an adhesive, or gummed paper. In joining the ends of ring No. 2 one twist must be given to the strip, while in making No. 3, the strip is twisted twice. The three rings should now appear as in Fig. 113, and if the strips are fairly long, the twists will not be noticed.

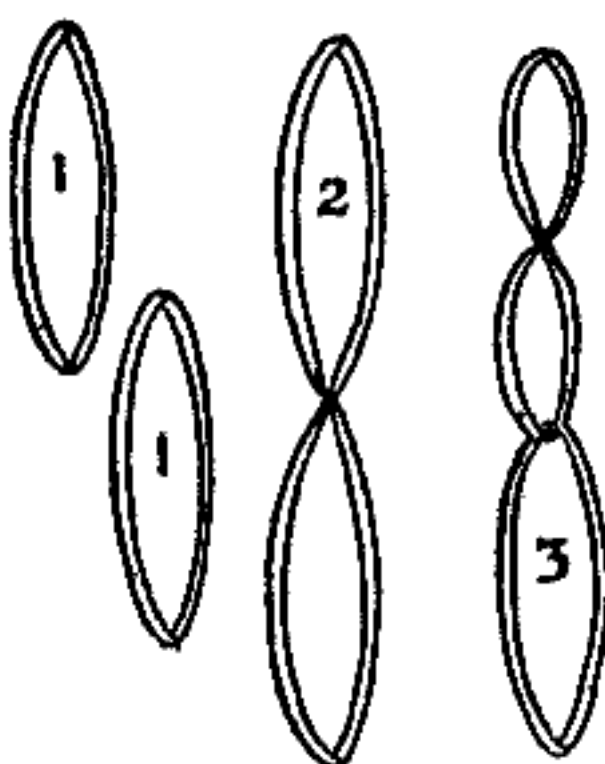

FIG. 114

If these bands are now cut through the centre they will appear as shown in Fig. 114

Patter

(The performer should provide himself with a fairly long pair of scissors, otherwise the patter will not outlast the somewhat lengthy process of cutting.)

Ladies and Gentlemen. Will you please take a good look at these simple paper rings and see that there is nothing concealed between them, individually or collectively. I propose to tell you a short story, and will illustrate my points with the rings and these scissors, whose points, I might mention, have nothing to do with my story.

The hero is a Mr. Smith, who was something in the City. On returning home the other evening he found his wife making some bands for sleeves. She took up a length of material similar to this and cut right along the centre, so, until at length she formed two complete rings. "There, I think that will do very nicely, and just the size for the other four I require," she said.

Mr. Smith remarked that some women made such a fuss over a simple little job, and that anybody could do a simple job like that, blindfolded. His wife replied that it was not so easy as it looked, and suggested that as she was very busy, perhaps Mr. Smith would not mind cutting the other four bands. With a "no sooner said than done" air he cut the band, but his face was a study when he found that he had not proved so successful as he thought he would have been. "Try again, dear, with the other band," said Mrs. Smith, sweetly, and "dear" did try. He cut very carefully and slowly. "There," he said triumphantly at last, "here are the two bands." But on looking he found that instead of two separate bands, he had produced one within the other, like this, so he gave over the job in despair to his wife.

[Next](#) | [Previous](#) | [Contents](#)

Paper Magic

Will Blyth

[Next](#) | [Previous](#) | [Contents](#)

Moths of Japan

Effect

Two small pieces of tissue paper are torn to represent moths or butterflies. Performer then takes an ordinary Japanese fan and fans the papers, which flutter about the room or stage as if endowed with life, settling anywhere the performer desires; then rising again and resuming their flitting. The movements are so natural that it is difficult to imagine that the papers are not living insects.

Working

The secret of the trick depends upon a few feet of fine black silk thread, but great skill and much practice are required for neat presentation. The papers are about the same size as ordinary cigarette papers, being roughly torn in the shape of butterflies. They are twisted in the centre to form the body, and the two ends are lightly pressed on one of the fingers to make the papers slightly concave, in order that the current of air produced by waving the fan may have full effect. The papers may, of course, be examined if desired. A piece of fine black silk thread is tied in the centre to the top vest button and the two ends loaded with a small pullet of wax. These are temporarily fixed on the lower vest button. When the moths are ready to commence operations, performer attaches one end of the thread to each of the papers by means of the wax pellet. An alternative method may be adopted by having the ends of the thread hanging down from the top vest button and fixing one end in each of the papers during the process of twisting up the paper, thus dispensing with the wax pellet. It is not possible in this case, of course, to pass the papers for inspection. The papers are now placed upon the palm of the left hand, which is held out to the full extent of the thread. The right hand picks up the fan and fans rather rapidly, to make the papers rise. Once in the air it will be found that a gentle wave of the fan from the body of performer towards the papers will be quite sufficient to make them flutter about with a surprisingly lifelike movement as Fig. 115. It is very important to note the foregoing method of using the fan; the current of air must not come from above or underneath the papers, but along the line of thread, otherwise it will be impossible to control the movements.

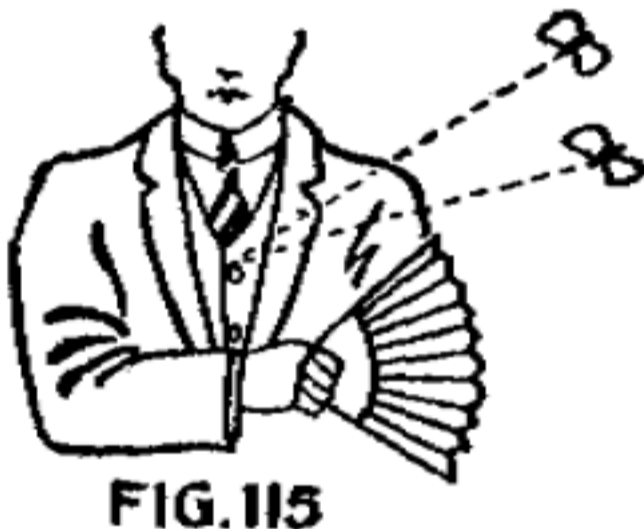

Of course one moth is far more easier to manipulate than two, and the novice is recommended to practise with one only at first, adding the other when fully proficient. A very pretty effect is gained by holding a flower in the left hand and allowing the moths to

settle down upon it. This is easily managed by a less vigorous use of the fan, thereby decreasing the air pressure. They are made to rise again and resume their wanderings by a quick action of the fan as at first. Some performers use a long thread unattached to the body, and by skilful manipulations with two fans, one in each hand, are able to keep the papers in motion. This feat, however, is very difficult to accomplish, and it is very doubtful whether it has any particular advantage.

Patter

Ladies and Gentlemen. This little effect I am about to show you was brought over from the land of chrysanthemums some years ago. Our climate, however, does not agree with Japanese moths, so it is, therefore, necessary to train home-bred ones. The quickest way to breed performing moths is to get two small pieces of tissue paper, tear them to shape, make a body in the middle, and there you are--or perhaps, I should say, there they are. If anyone present is interested in insectology they are welcome to come up here and closely inspect the organisms of these little creatures. Now to breathe into them the breath of life. This fan really does the breathing. just a little flutter and you see that the flitters flit. Now high--now low--gently my little dears. On the table; off again! just like little illusive will o' the wisps. They now appear to be getting a little tired, and so you see they settle down to rest. This affords an opportunity to anyone who wishes to examine them, and if anyone present is a collector of moths, they are welcome to take away as a memento one of these beautiful little specimens.

Note.--In place of the foregoing patter, a gentle running waltz air, played on the piano, provides an appropriate accompaniment to the graceful movements of the moths.

[Next](#) | [Previous](#) | [Contents](#)

Paper Magic

Will Blyth

[Next](#) | [Previous](#) | [Contents](#)

An Orchard Story

Effect

Entering with an unprepared newspaper, the performer, by simply rolling and tearing various pieces of it, makes a Tree, Fence, Ladder, and finally a Group of Dancing Brownies; telling a story as he forms the various articles.

Working

THE TREE. The paper should in this case, and in all other effects be first exhibited both sides, "in order to show that there is no deception." Tear the doubled page right across about ten inches deep, twice (Fig. 116), forming two long strips ten inches wide. Roll up one strip, not too lightly, and when complete roll the other over it, allowing end of first piece to overlap the edge of second piece, Fig. 117. Then lightly flatten the top, and make three cuts from top to centre of roll (Fig. 118).

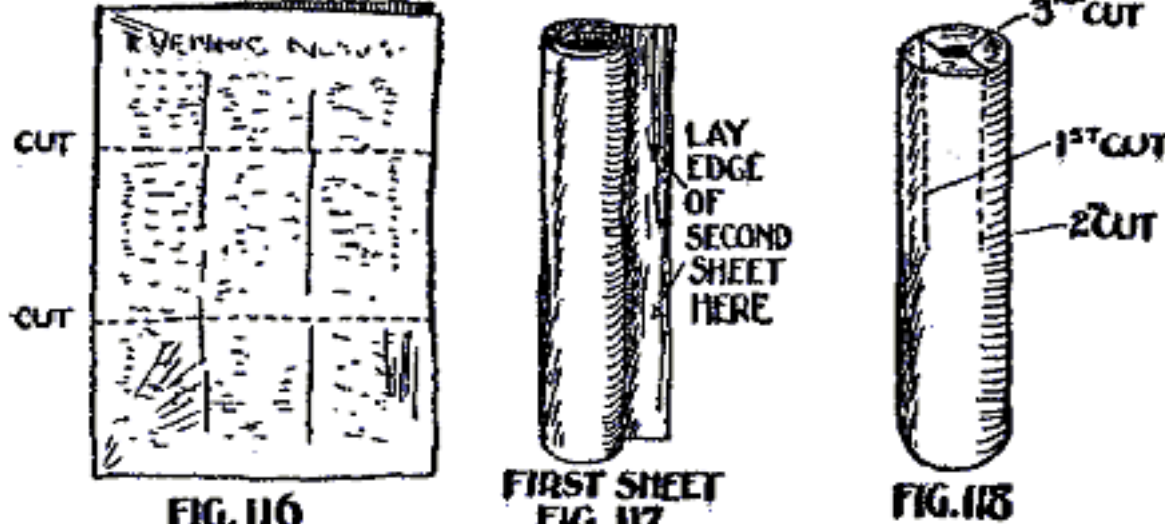

It will be noticed that two incisions are made by the first cut by reason of the roll being cut through in its flattened condition. It is now an easy matter, to make two more cuts, equi-distant from the first cut, thus making four lots of strips at the centre of the roll (Fig. 119). Hold the lower part of the roll firmly in the left hand, and with the right pull up the centre strip, when the tree, will appear in all its pristine beauty. (Fig. 120.)

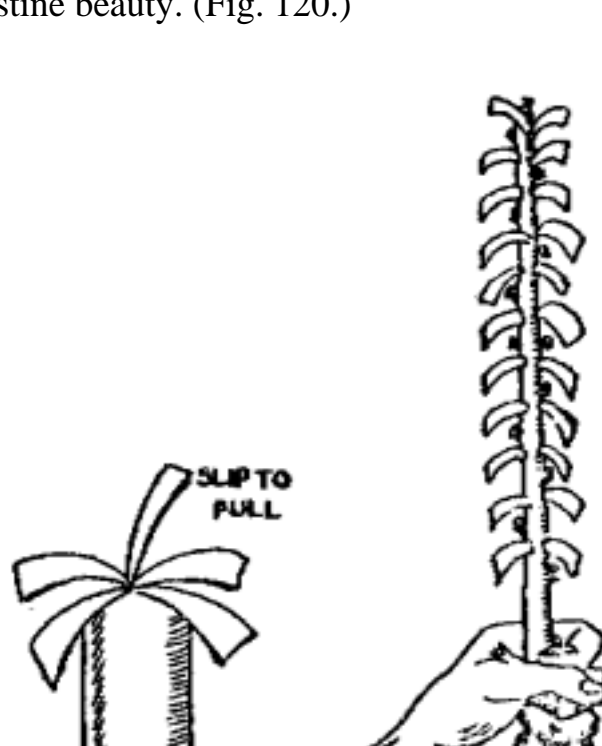

Although it is not absolutely essential, the effect is considerably enhanced by the tree being planted in a Pot. An ordinary small earthenware flower pot with a cardboard disc fitted in the top, having a small hole in the centre of the disc to take the tree, will be found admirable for the purpose.

FENCE. Tear a slip about six inches wide off a doubled page of newspaper and fold in pleated fashion as shown by dotted lines in Fig. 125. Then fold in half, A to B, in order to reduce time taken to tear paper. Make a series of cuts along the edge about one inch apart and about three-quarters of the way down; then another series of similar cuts along the other edge, so that they pass partly between the top ones (Fig. 122).

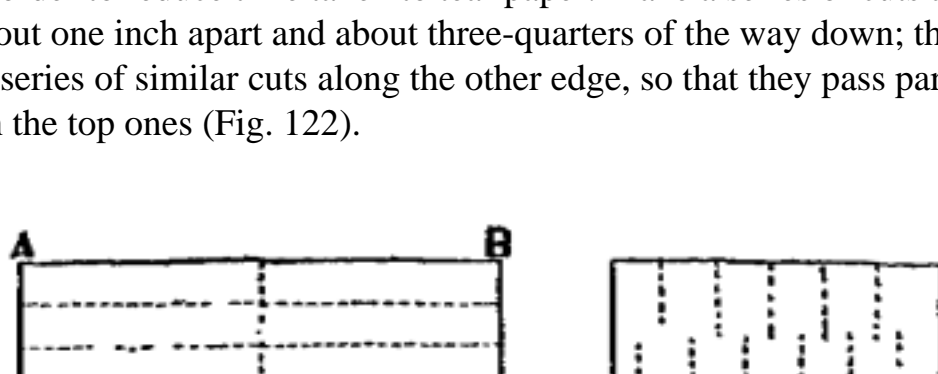

At the extremes tear as closely as possible to the end, because these being of doubled paper will, when opened out, be double the size of the other pieces. Great care must now be taken in opening out the fence, which should appear as Fig. 123.

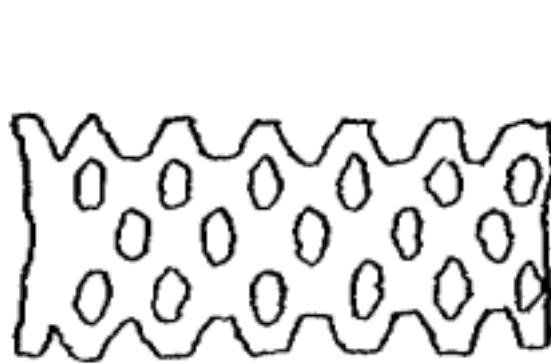

LADDER. For this beautiful effect tear from a doubled page of newspaper a strip about ten inches wide and make a roll, not too tightly. This should then be torn in the centre as shown by the dotted lines in Fig. 124, the shaded portion being torn completely away. If the roll is pressed together it will be found easy to tear through the complete roll.

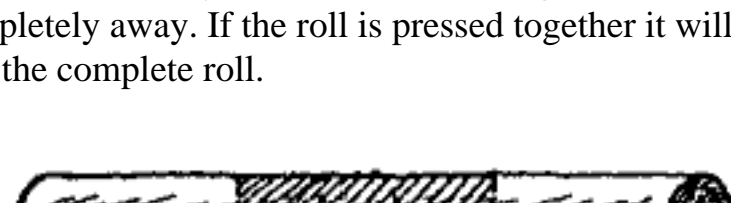

The ends A and B are now bent downwards as in Fig. 125, and it will be found that by gently pulling the top slip of paper a perfect ladder will emerge with flat steps and rounded sides. (Fig. 126.)

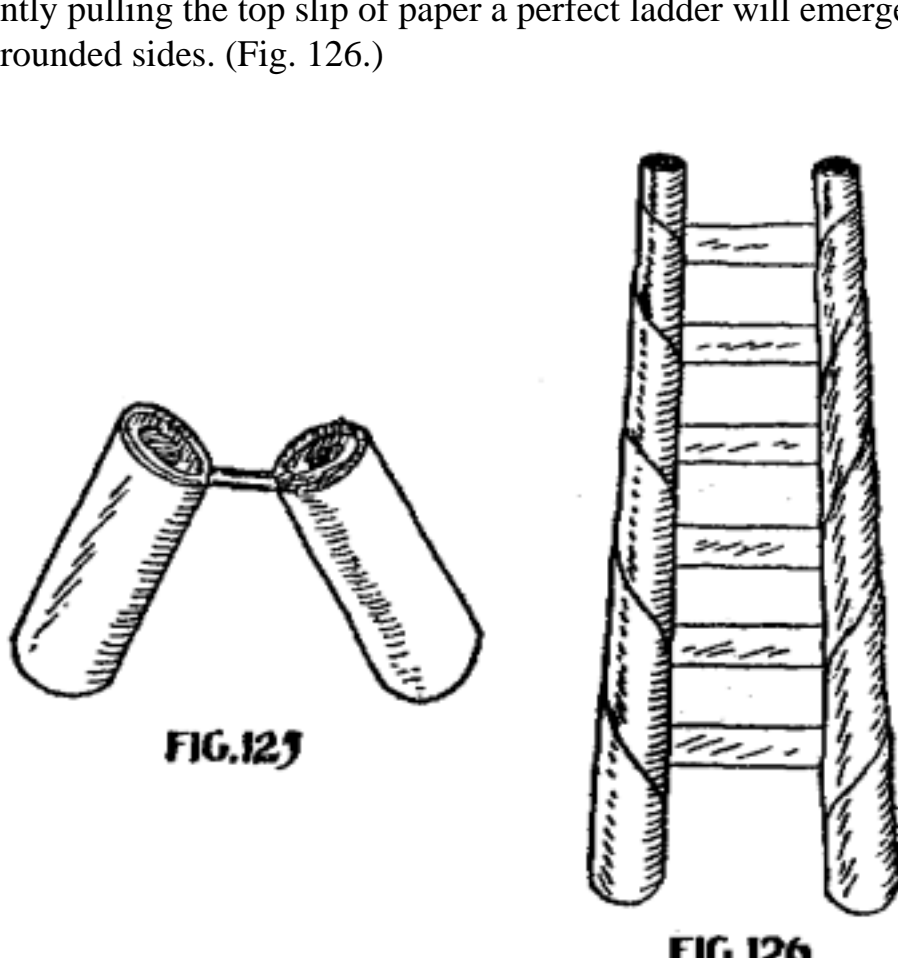

If a longer ladder is required, two strips of paper may be used as directed for making tree. (Fig. 120.)

GROUP OF DANCING BROWNIES. A double page slip of newspaper about ten inches wide is required, and must be pleated about one inch wide. Tear or cut as shown by the outline in Fig. 127, and when opened out a row of quaint little dancing Brownies will be discovered. (Fig. 128.)

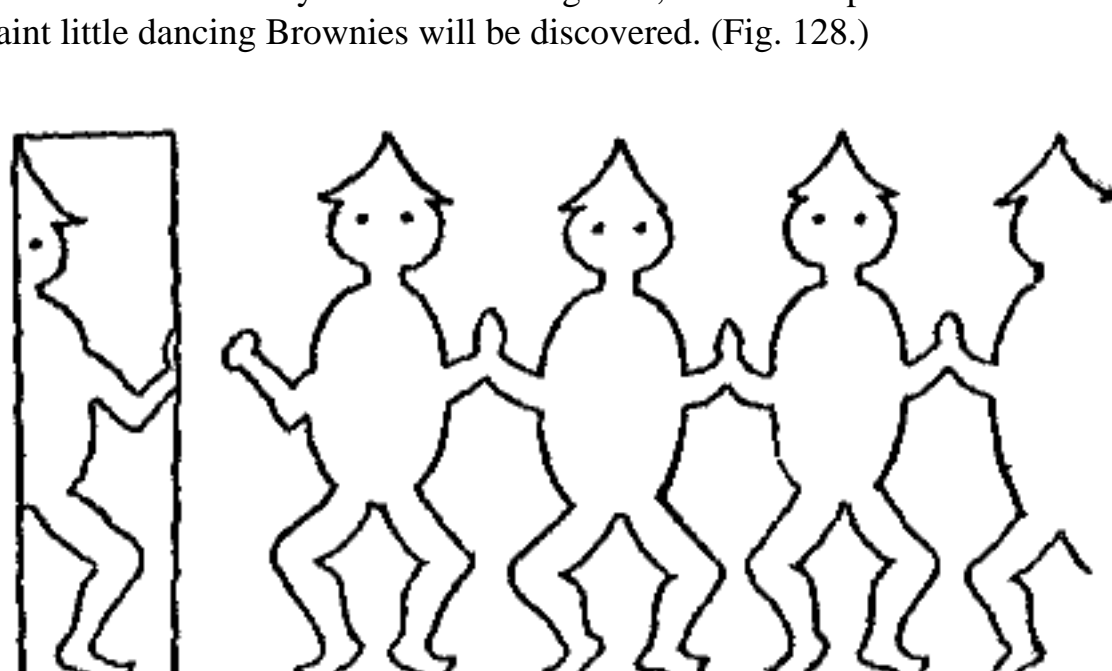

Patter

The patter must run on throughout the whole development of the story. There should be no awkward pauses while any item is being prepared or rolled. Ample opportunity will be found for introducing set gags or jokes where a slight delay is likely to occur, as nothing is more likely to make an audience restless and impatient than a tedious wait while nothing in particular is apparently being done.

The following patter is purposely written in the fullest style, but performers can, of course, cut or add in any part according to their requirements. The important point to bear in mind is, that the interest of the spectators must be sustained from start to finish.

Ladies and Gentlemen. For some years past many experiments have been made with the object of discovering how to manufacture substitute articles. Margarine has been made from coal; the Germans endeavoured to make bread from sawdust during their war shortage of flour, but I don't think that they were very successful. Manufacturers have, however, been able to make paper from trees, and a farmer in Blankshire hearing of this thought that he would try to reverse the process and make a tree for his orchard from paper. He took a piece of newspaper like this (and, by the way, I might tell you that although this now looks like an ordinary black and white, newspaper, you may be surprised to know that only yesterday it was read (red) on both sides); as I said, he took the paper and rolled it up, so (I am going to do this slowly, so that I shall be able to do you more quickly). Then making these incisions down the stem he produced his tree, which he placed in a pot. Of course he placed the tree in the pot, because he found it so much easier than placing the pot in the tree.

It was very necessary that he should place some protection around the tree to prevent naughty boys from helping themselves in the autumn to his rosy-cheeked apples, so he took another piece of paper and proceeded to make a fence. Whilst showing you how he made this, may I say how pleased I am to see so many happy faces here this evening. So glad you came, because it is not always those who are asked who come. It reminds me of a story I read the other day about an old lady who invited two soldiers to tea with her. On the appointed day only one soldier appeared in response to the invitation. "Why, where is your friend," said the old lady. "Well, mum, we couldn't both get away, so we tossed for it," he replied. "Oh, and I suppose you won," said the old lady with a smile. "No, mum. I lost," was the unexpected reply. Now you see we have the fence ready, and I will place it around the tree as the farmer did. When the apples were ready to be gathered, a difficulty arose as to how to reach the top branches. He wanted a ladder, and in order to get one he again took a piece of paper and made a roll, so. There is one peculiar feature about ladders which possibly you may not have noticed, and that is, that some of them are larger than the smaller ones. This is going to be one of those. Having completed the roll he made two bites in the centre, removed a mouthpiece, bent down the ends and pulled up the ladder, thus. He set this against the tree and found that he could easily reach the apples.

Now you know that hiding in many forests are a tot of little fairy people called Brownies. At nightfall they come out and indulge in all sorts of antics. A number of them were seen by the farmer one night dancing around his apple tree, and he illustrated to his wife what he had seen by taking a piece of paper which he pleated like this, and then cut it round and round, until on opening out the paper he was able to show her what a row of dancing Brownies. These I will place around the tree, and we shall then see them as the farmer did. I might perhaps add in conclusion, in the words of all good fairy stories, that they lived happily ever afterwards.

[Next](#) | [Previous](#) | [Contents](#)

Paper Magic

Will Blyth

[Next](#) | [Previous](#) | [Contents](#)

Bewildering Tissues

Under this heading will be recognised the principle of a well known handkerchief effect--the Sun and Moon--the present version, in which only paper is used, is claimed to be an improvement on the latter and just as effective. In addition to which the cost is purely nominal.

Effect

Two small sheets of tissue paper, one white and one red are displayed, and a round hole cut in the centre of each. The papers are twisted together and set alight. From the ashes the performer then produces the papers restored whole, but finds that the centres have become somewhat mixed, and that the white paper has a red centre and the red paper has a white centre. The papers are rolled together again and given to a member of the audience to hold; A pass is made with the magic wand--the paper roll is opened out, when the centres are found to have returned to their proper places and the red and white sheets of tissue paper are shown whole as at first.

Working

A little preparation is necessary before commencing this trick. Three sheets of red and three sheets of white tissue paper are required. A hole is cut in the centre of one of the red sheets and a round piece of white tissue paper pasted over the hole (Fig. 129). A white sheet is similarly prepared, with a red circular centre. (Fig. 130.)

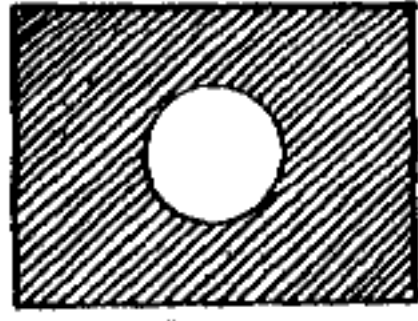

FIG. 129

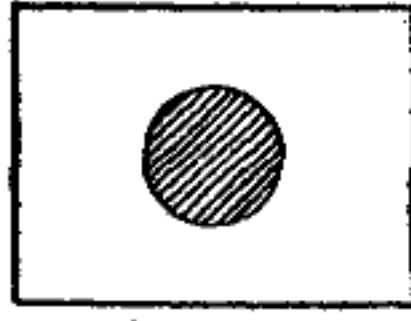

FIG. 130

These are placed together, rolled into a ball, and placed under the bottom of the vest on the left side. A sheet of red and a sheet of white paper (unprepared) are also rolled together into a ball and placed under the bottom of the vest on the right side. The remaining two sheets of paper are laid upon the table and are exhibited freely to the audience when commencing the trick. They are placed together and folded as shown in Fig. 131, making the paper one-fourth its original size. An assistant is obtained from the audience, and he is handed a pair of scissors and asked to mark the paper by cutting a small piece off the bottom. Performer holds the paper with both hands so that he is compelled to cut at position shown by dotted line in Fig. 131.



FIG. 131

When the paper is opened, a large round hole will be found in the centre of each sheet. Do not omit at this stage of the proceedings to show each sheet and the cuttings, in order that the audience may thoroughly grasp the fact that holes have really been cut in the papers. Go to the edge of the platform to exhibit the sheets, and while there roll them into a ball with the cut out pieces. In returning to the

table for a candle, get the vested roll of prepared papers from the left side into the left hand, while the right side of the body is towards the audience. This is quite easy to do undetected, and the papers are held concealed in the left hand. The candle is then lighted and the roll of torn papers ignited. When the papers are almost consumed the two hands are brought together, and the concealed papers in the left hand are produced as if from the ashes of the burnt paper. The roll is opened, and the two sheets of paper with the misplaced centres held out to the audience for inspection, with the left hand. The performer then makes a half-right turn to the audience, providing himself with good cover, to get possession of, and conceal in the right hand, the "vested" papers on his right side. The exhibited sheets are crumpled together with both hands, and an exchange effected with the concealed ball in the right hand, which is now handed to a volunteer assistant to hold, the roll of exhibited sheets being retained concealed in the right hand. Performer now picks up wand from the table and makes a pass. The assistant is then requested to open the roll, when the papers are found to have regained their correct centres and both are handed to the audience for examination. While the assistant is opening the roll, performer should casually place right hand in pocket and get rid of the concealed papers.

Patter

Ladies and Gentlemen. I shall have much pleasure in showing you a little effect with these two sheets of paper, and shall feel obliged if someone will, kindly volunteer to act as an assistant. Someone who has never seen me before, or, if not, someone who never wants to see me again, will do. Thank you, sir. Will you please sit down and make yourself quite comfy. How do you like the weather? Rather colder than the hot, is it not? Now, sir, I have folded these two pieces of paper together, and so that we may both be able to identify them again I want you to mark them both by cutting a small piece off of this corner. That's right. You certainly have marked them. I am afraid that their won mother would hardly know them now. I think that I had better endeavour to get the pieces back again. Perhaps they will stick if I heat them a little. Hallo! I am afraid we have overdone the thing now. No, it is quite all right, of course this is a magical feat, and in magic you can never make sure of your chickens until they are hatched. That is by the way however. Here is a roll of papers rising from the ashes. Will you please open it; and if the experiment has been successful we shall find that the centres have been restored. What did you say? Some mistake? Oh, I see, the colours have got into the wrong centres. So sorry. Of course, I quite forgot to give the healing touch with the magical wand. You see, ladies and gentlemen, what has been the result of my little omission. The only thing I can do now is to roll them up again and ask you to kindly hold them. I will now take the magic wand and make the pass, so. Now will you please unroll the papers. You see they are quite normal, and I shall feel obliged if you will kindly pass them among the company for their minute examination. Thank you for your kind assistance.

[Next](#) | [Previous](#) | [Contents](#)

Paper Magic

Will Blyth

[Next](#) | [Previous](#) | [Contents](#)

Paper Tearing Act

This effect should not be despised because no apparatus or great skill is required in presentation, As with many of the items in this book, the all-important factor is the method of presentation. Badly presented, the whole proceedings will appear childish, but well presented, with pleasant patter, pithy story, or musical accompaniment, an interesting and instructive entertainment will result. Some of the designs will appear to be absolute works of art, and look exceedingly pretty when placed against a dark background, and it will be found that this item will often bring forth more applause than an effect involving dexterity, which has taken the performer months of practice to bring to perfection.

There are many features or novelties in the category of a paper tearing act, but for popularity, Fancy mats, or, as some prefer to call them, Antimacassars, are an easy first. These are closely followed by the Ship's Wheel, but in addition there are Baskets, Boxes, Chains, Border Designs, Flower Pot Decorations, Hats, Ships, as well as rows of animals, old men, fairies, etc., etc., from amongst which a selection might be made to form a pleasing programme, not only for children but for adults also.

Some performers tear the designs with hands placed behind the back, and others, whilst they are blindfolded, but, of course, it is necessary to be absolutely "word perfect" before adopting this method of presentation. Of course, if coloured papers are used the effect is far more pleasing, but these are not absolutely essential. The wholly inexpensive newspaper will be found quite suitable for the purpose and there is no possibility of any suspicion as to deception in the manufacture of the paper.

Folding the Paper

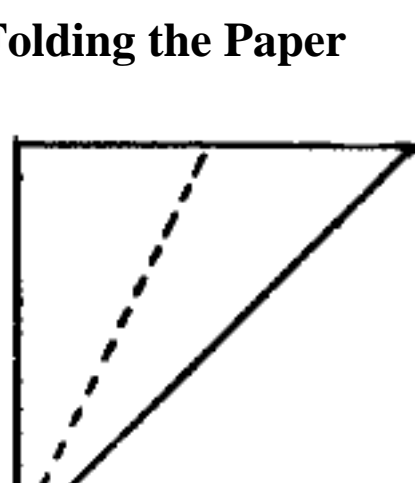

Take a square of paper and fold it in half, then in half again, thus forming four squares of paper, one quarter the size of the original sheet. Then fold one corner to the opposite corner, making eight triangles folded together (Fig. 132).

Lastly, Fig. 132 is folded in half, as shown by the dotted line, and the paper is then ready for tearing into a Paper Mat or a Ship's Wheel.

Fancy Mats

There is no limit to the number of different designs that can be formed into mats, like a child's kaleidoscope, a fresh combination greets one at every turn indeed, it is easier to produce different patterns than to produce them quite alike. Two outlines are given as examples of the method of tearing fancy mats in Fig. 133, either of which will be found to open into a pleasing pattern, but the entertainer will soon find that the more haphazard and irregular the tearing, the more effective will be the completed mat when opened out. The reason for this, of course, is that each hole torn out represents only half a hole. The other half is faithfully repeated and the complete hole is contained eight times in the unfolded mat.



A pleasing variety is formed by producing a design for a Card Table Cover, consisting of a series of hearts, diamonds, spades and clubs, in all, eight of each suit. These may be torn in various positions, and one example will be found in design of Fig. 134.

Ship's Wheel

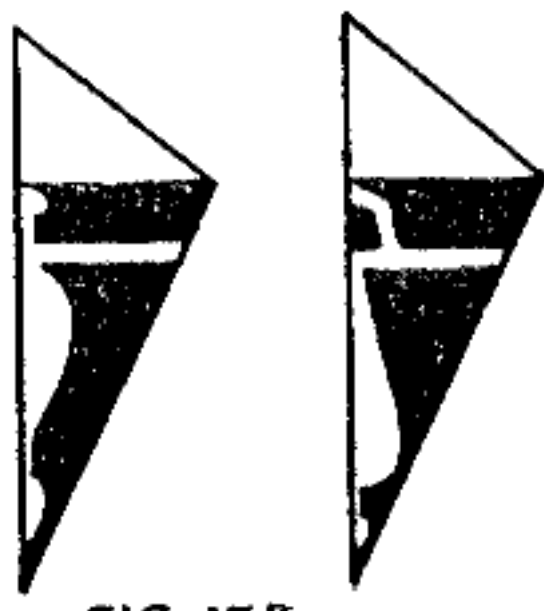

This design is really easier to produce than the fancy mat and can be done in less time, but the effect is none the less pleasing, the geometrical figures of the eight segments looking most businesslike. This may, however, if preferred be presented as a "spinning wheel." Fig. 135 shows designs for two types of ship's wheels.

Mantel Border



For this effect use a long piece of paper about three or four inches wide and fold in pleated fashion, making the pleats about two inches wide. Suggested forms of design are given in Fig. 136, but the design, as well as the size of paper employed, must be according to the performer's fancy. After the design has been opened out it can be fixed to the edge of the table with the aid of a couple of pins. If the table happens to have a dark cover, a very pretty effect will be produced.

Flower Pot Decoration



This forms a charmingly effective little item. The design is shown in Fig. 137.

The paper used should be about eighteen inches long by about five or six inches wide and must be folded into one-inch pleats.

After tearing, a piece of bright red ribbon is threaded through the centre slots of the pattern and finished off with a double bow, the effect of the contrast of the coloured ribbon against the white paper being very pleasing. The performer should have an old flower pot handy, the dirtier, the better--and when the bow has been finally tied the decoration can be placed around the flower pot, thereby transforming an unattractive object into "a thing of beauty and a joy for ever."

Patter

It is a very difficult matter to keep up a running flow of patter during a paper tearing act, and there is no doubt that a pianoforte accompaniment is the best for all, except the most voluble performers. At the conclusion of each item, however, a signal might be given to the player to stop for a time, thus affording an opportunity for the delivery of one or two bon mots, something after the style of the following:-

Fancy Mats

"Here you see we have a beautiful table centre, but strange to say (turn paper round) on this side, also, we have a beautiful table centre. This side is something like the other side, and, what is perhaps more remarkable, the other side is something like this side.

I tear a hole in the paper, but, of course I want the whole of the paper, otherwise it would not be complete.

Ship's Wheel

This is the article referred to in "Anchored" (Sing)

"And glad was the sailor lad
As he steered and sang at his wheel."

You often hear the saying, "For weal or woe this is the "wheel," and of course you get "whoa" when you want to stop tearing the paper.

Spiteful persons are sometimes heard to threaten to "put a spoke in someone's wheel," so you had therefore better treat me very kindly, because you will notice that I am able to put no less than eight spokes in a wheel.

Mantel Border

Just a little decoration for the mantelpiece. Of course it should hang above the fire, but if you are not quite satisfied with it, you may hang it on the fire.

Flower Pot Decoration

Here is a nice little present for mother, finished off with a dainty little Sunday bow. I am placing the decoration around the pot, because I find it much easier than placing the pot around the decoration.

[Next](#) | [Previous](#) | [Contents](#)

Paper Magic

Will Blyth

[Next](#) | [Previous](#) | [Contents](#)

Spirit Calculator

Effect

Two pieces of paper are shown by the performer to be quite blank. One of these is folded up and given to someone in the audience to hold. Another piece is passed round to five persons in different parts of the room, who are each asked to write three figures upon it. The paper is handed to a sixth person, who adds up the five sets of figures. The total of this sum is then found to agree with figures found upon the paper, which was shown blank at the commencement of the trick. Another blank piece of paper is then given to a gentleman to hold, and the gentleman holding the totalled sum is asked to erase either the first two or the, last two figures. The numbers erased are then called out, and are found to be written upon the paper which was previously seen to be blank.

Working

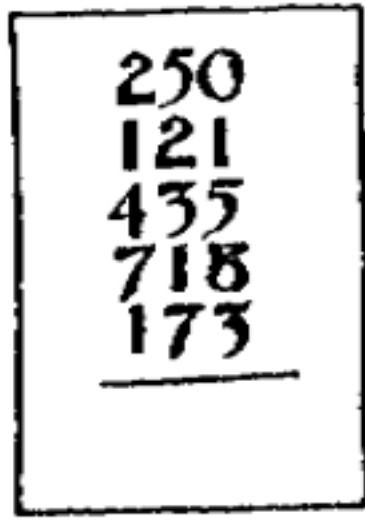

FIG. 138

Have two pieces of blank paper upon a plate or small tray, and hand to a gentleman to examine, asking him to take one and fold it. Then hand him an envelope for examination. While this is taking place, the folded blank paper is changed for a similarly folded piece of paper which has the number 1697 upon it. This had previously been concealed in the right hand, or held against the underside of the plate with the fingers. Now hand another blank piece to the audience, taking it to five members in turn, asking each of them to write three numbers upon it in the form of an

addition sum. After the fifth set of figures has been written, the last writer is asked to fold the paper twice and place it upon the plate. The plate should be held in the right hand, with the thumb underneath, and the fingers flat on top, concealing a duplicate folded paper with sets of figures written upon it as Fig. 138. (See Fig. 139.)

In moving across the room to ask someone to add up the sum, the plate is passed to the left hand. The fingers of the latter now close over the sets of figures written by the audience, leaving exposed on the plate the folded paper containing the figures

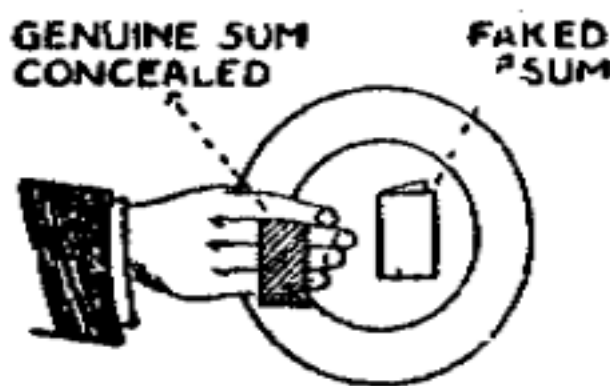

FIG. 139

of performer. The plate is then offered to a gentleman, who is asked to total the figures of the "faked" sum (Fig. 138). This gives performer an opportunity to dispose of the genuine figures written by audience.

The total (1697) is then read out, and on opening the envelope held by the first gentleman, he finds that the paper inside has the same figures written thereon.

Another blank paper is handed for examination, and is changed, as previously described, for a duplicate with the figures 16 written upon it. This is placed in an envelope as before and retained by a member of the audience. The paper on which is written 1697 is handed to a gentleman, with the request that he will erase either the first two or the last two figures. He is then asked to state the remaining two figures. Should he state "16," ask for the envelope to be opened and the paper examined and anything upon it called out; this, of course, is 16. If the gentleman who erased the figures should say "97," ask him to add them together. This makes 16, which, of course, agrees with the figures written on the piece of paper found in the envelope.

Patter

Ladies and Gentlemen. I should like to point out that all my effects are the result of pure natural magic, and that nothing of the supernatural enters into them. The title of my present item, however, appears to indicate that I am resorting to other powers than my own to achieve the result, but I can emphatically state that I am simply depending upon absolute concentration of the medulla oblongata. So now you know all about it. First, I would ask you to examine these two pieces of paper. Would you be good enough to fold one in half, and again. Now please examine this envelope. and make sure that it is quite unprepared. Are you quite satisfied? Will you now place the folded paper inside and seal the flap down. I shall now pass the other slip to five members of the audience, and would ask each of them to write three figures upon it, the five sets forming an addition sum.... Now, sir, you have written the fifth set of figures; will you please fold the paper twice and put it upon this plate. In order to exclude the possibility of confederacy, I will ask another gentleman to total the sum written by the audience. Thank you. Will you please, read out the total-- "1697." Now, if the gentleman holding the envelope will kindly open it and look at the blank piece of paper which he placed inside, he will find this total written on it by some mysterious hand. Here is another piece of blank paper. Will you please examine it carefully, madam, fold it twice and place it upon the plate. Now kindly select one of these envelopes and examine it thoroughly. Please place the folded blank paper inside the envelope, and hold it tightly so that I cannot possibly get at it without your knowledge. Will the gentlemen with the totalled sum please erase either the first two or the last two figures. Please call out the remaining two figures, "9 and 7." Thank you. Please add the two together and call out the result, "16." Will you kindly open the envelope, madam, and examine the blank paper and you will find that the mystic hand has again been at work and written the figures 16 upon it.

[Next](#) | [Previous](#) | [Contents](#)

Paper Magic

Will Blyth

[Next](#) | [Previous](#) | [Contents](#)

Thought Reading

Effect

A member of the audience writes a question upon a piece of paper which is sealed in an envelope, A blank piece of paper is placed in an envelope and given to a gentleman to hold. The performer now calls out the question, which is found to agree with the one written upon the paper in the first envelope. Upon the second envelope being opened, an answer to the question is found written upon the blank slip of paper.

Working

A gentleman is asked to write a question on paper. This may be done on a small writing pad with an interleaved carbon sheet, or a single piece of paper, the back of which has been previously rubbed with a candle or piece of soap, is handed out on a piece of glass or small photograph frame. The latter is certainly the better, as it appears quite free from any prearrangement. If a hard pencil is provided, a faint impression of the question will be found on the glass, or, if a pad is used, the impression will be found under the carbon sheet. The performer hands an envelope to the writer of the question, requesting that the message be folded and placed therein. He then returns to the platform, and is able to read off the message on his way back. In his right hand trousers pocket is a small piece of soft lead pencil and a small piece of cardboard with a slip of paper attached by two rubber bands, As soon as the question is read, a brief answer is written (within the pocket) upon the paper (after a little practice this will be found to be quite an easy matter), and the paper detached from the cardboard and folded. A blank piece of paper is next given for examination and the exchange effected with the "answer," as described previously. (Spirit Calculator). The trick is now complete, and the effect on the spectator when the question and answer is read out is startling and inexplicable.

Patter

Ladies and Gentlemen. Most of you probably know that during recent years there have been surprising manifestations of hypnotic power and influence of mind over mind. To-night I hope to show you an example of how the thoughts of one mind may be transmitted to another, without physical contact. Will you, sir, please write a question upon this piece of paper. Thank you. Now please fold it, so that I cannot see what you have written, and place it in this envelope, which please seal and retain. Will you, madam, kindly examine this slip of paper and see that it is quite blank, and please fold it twice. May I trouble you to examine this envelope well, and now will you kindly put the paper in the envelope. Now, sir, will you please look straight into my eyes and think deeply of the question you have written. Keep on repeating it to yourself. Thank you. The question you wrote was _____. "Will you please open the envelope and read out what is written on the slip, so that the company may be able to see whether I have been able to read your thoughts correctly. I am now going to cause a spirit answer to your question to appear upon the blank slip of paper. Just a touch with the magic wand and the answer is there. Will you kindly open the envelope, madam, and if the answer has been recorded, as I think it has, will you please read it out. Thank you. Thus you see I have successfully demonstrated the wonderful power of thought divination.

[Next](#) | [Previous](#) | [Contents](#)

Paper Magic

Will Blyth

[Next](#) | [Previous](#) | [Contents](#)

Mind Divination

Effect

A word or sentence is written on a slip of paper and folded. This is held against the performer's forehead for a moment, but he does not touch the paper. He then writes upon another slip and hands it to a gentleman to hold. The first slip is opened and read out, upon which the gentleman holding the slip written by performer acknowledges that it agrees with the other writing.

Working

This is really a catch, but if due care is taken in the selection of an assistant the secret is not given away, and credit is given for a mystifying trick. It may at once be stated the performer has no knowledge whatever of the subject written upon the first slip until it has been called out. He simply writes on his slip "Yes, exactly the same," and this he hands to his temporary assistant. The remainder of the working can be followed in the patter. An alternative method of producing the same effect is by writing "Say Yes" on the slip. The performer in that case asks his assistant, "Have I written that word upon my paper." It will be found that in most cases the assistant will appreciate the joke and answer "Yes."

Patter

Ladies and Gentlemen. Just a little experiment in mind divination. For this I should like to have the assistance of a gentleman with a good nerve. "I suggest an insurance agent. Not one present? Well, perhaps you, sir, would be good enough to assist. Please take this slip of paper to that gentleman and ask him to kindly write a word upon it. When he has done that, please ask him to fold up the paper and return it to you. Thank you. I will now take the paper and hold it for a moment against the centre of my concentrated mind. It is gradually forming. Yes, I can now see the letters distinctly. I will write them upon this slip and ask you, sir, to take charge of it. Now, will the gentleman who wrote down the word kindly read out what was written. Thank you. My assistant will tell the company what is written upon my slip. I am anxious that the audience shall see that my writing entirely agrees with that written by the gentleman. Now, sir (to assistant), You heard what that gentleman said was written upon his slip. What is written upon my slip? "Exactly the same."

[Next](#) | [Previous](#) | [Contents](#)

Paper Magic

Will Blyth

[Next](#) | [Previous](#) | [Contents](#)

Gains of the Great War

Effect

By folding and tearing three small pieces of newspaper, the performer produces a German Iron Cross; the Allies' Star of Victory; and, finally, the Altar of Supreme Sacrifice.

Working

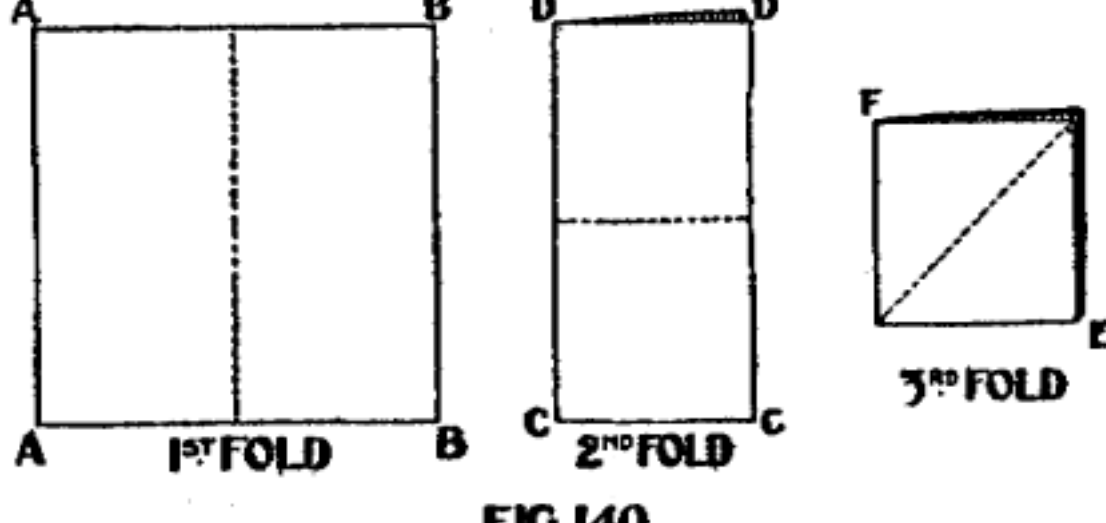

GERMAN IRON CROSS. Tear a piece of newspaper, about five inches square, and fold three times, as shown in Fig. 140, folding A over to B; C over to D, and E over to F.

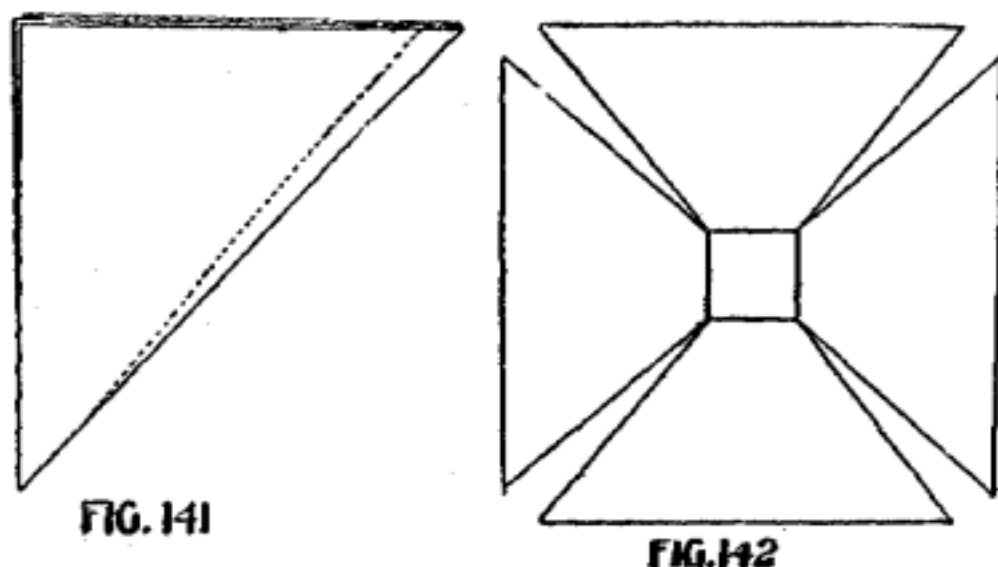

Now cut away the dotted line on Fig. 141, and when the paper is opened out the iron cross will appear as Fig. 142.

STAR OF VICTORY. Take another piece of newspaper, about five inches square, and fold A to B, of Fig. 140 (Iron Cross), following with the three separate folds indicated by the dotted lines in Fig. 143

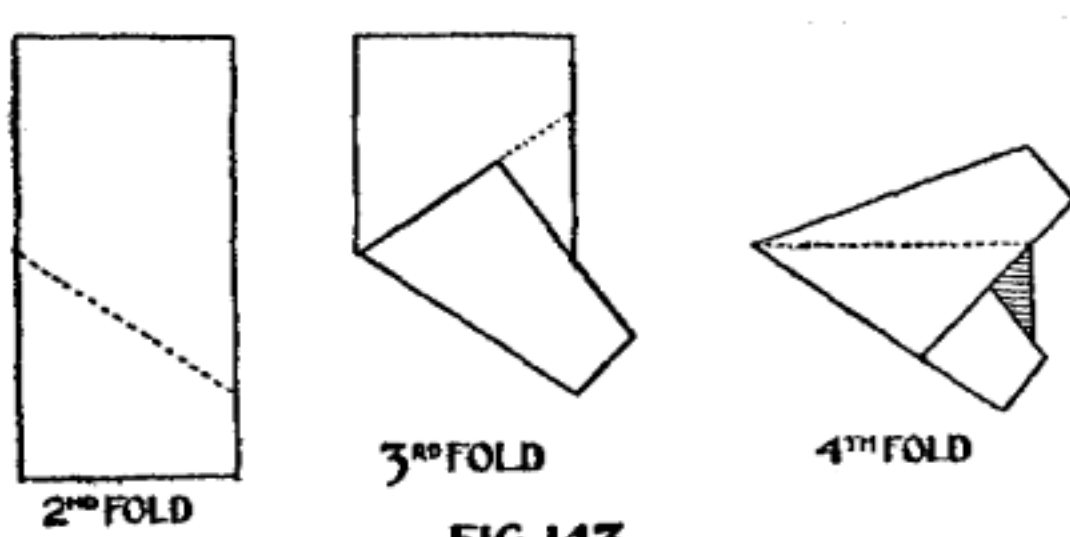

After the final fold (Fig. 144) cut along the dotted line shown, and the smaller piece when opened out will be similar to Fig. 145.

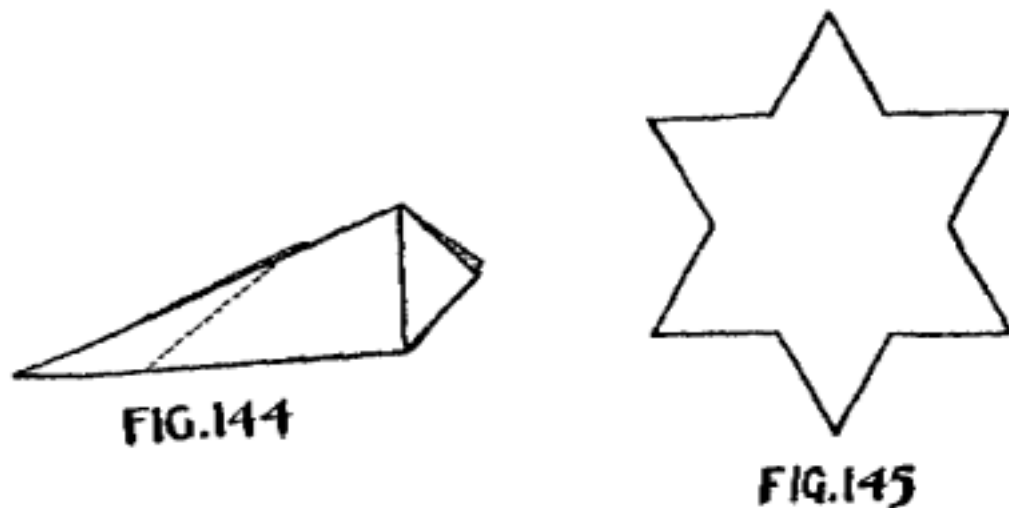

CROSS OF SUPREME SACRIFICE. For this simple yet attractive altar setting tear a piece of paper about eight inches by five inches, and fold the upper corners as shown in A and B, Fig. 146, folding A to the right and B to the left. Next fold the paper in half, lengthwise, as C. Fold again in a similar way, and the final fold D is produced.

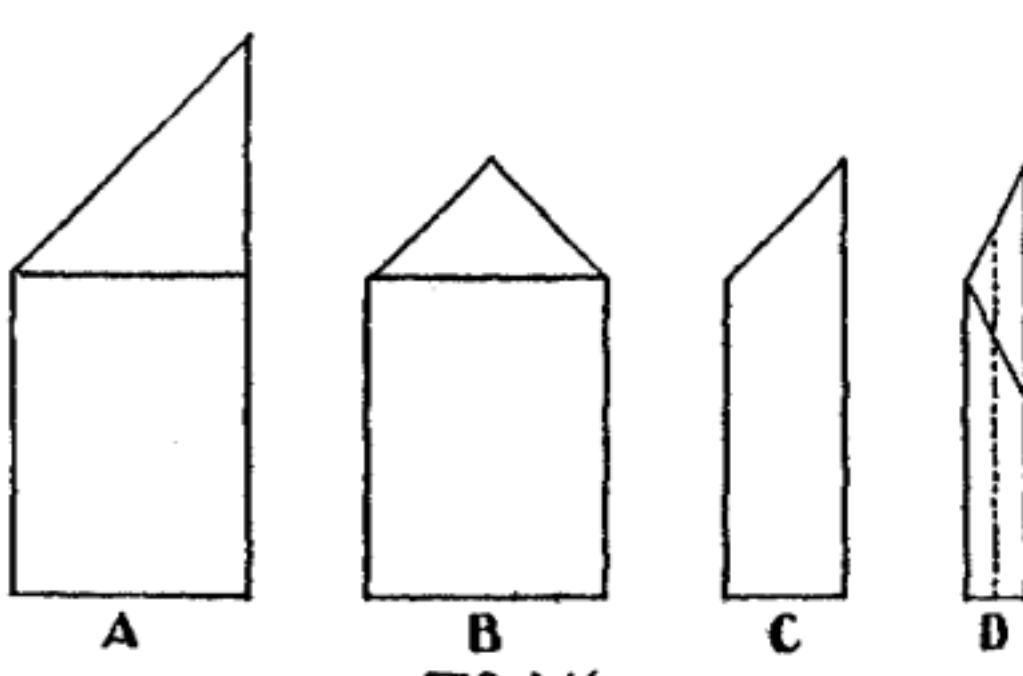

This must now be cut through the centre as indicated by the dotted line in D, of Fig. 146, when it will be found that the various pieces, when opened out, can be arranged as a beautiful altar setting similar to Fig. 147.

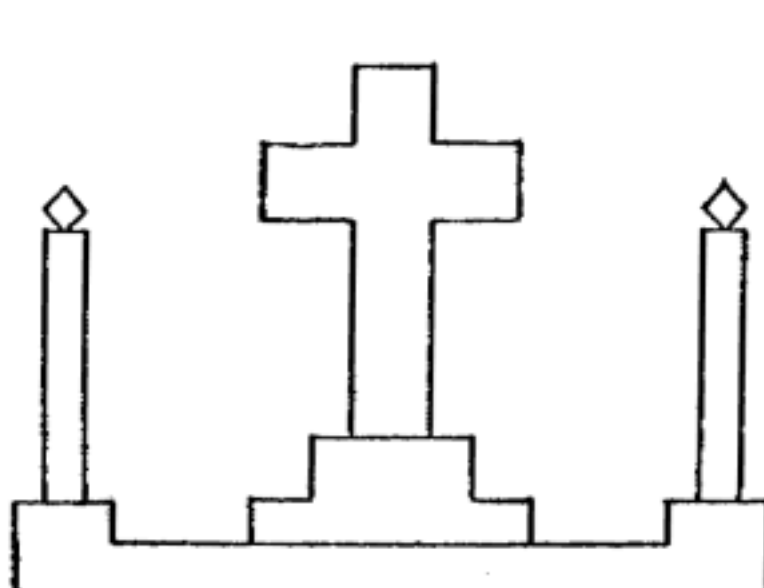

Patter

Ladies and Gentlemen. I am going to illustrate to you, by means of these pieces of paper, the gains of some of the nations in the great war. I am only using a small piece of paper each time, an economy learnt during the late war, when there was rather a shortage of paper, in fact the shortage became so acute during the latter days of the war that the paper trade was almost stationary. That, however, is by the way. This small piece will serve to illustrate what the Germans have gained. Not very much, as you may well imagine. Here it is! An exact representation of the Iron Cross of the All-Highest. Then there is the gain of our great nation and its Allies. This is rather a large matter to show with such a small piece of paper, but it is not so much what it is as what it indicates, and here is indicated the Star of Victory. A well-earned and glorious reward. But there is a sad side to this, when we remember our brave lads who have fallen. This paper will show their gain. They have fought a good fight in a noble cause and have gained the Cross, which you see represented here. By placing the other pieces around we see the Altar of Supreme Sacrifice. May their souls rest in peace.

[Next](#) | [Previous](#) | [Contents](#)

Paper Magic

Will Blyth

[Previous](#) | [Contents](#)

L'Envoy

Just a brief word of farewell to the reader. The compiling of this book has been a most pleasant occupation, and it is hoped that it will prove to be a useful addition to the bookshelf of the enterprising schoolboy and the amateur entertainer.

The subject of paper magic is, however, by no means exhausted; in fact the second part of the book merely touches the fringe of that branch of paper magic. Should the present book, therefore, meet with the success its author hopes it will, then it is quite possible that he may renew the acquaintance of his readers in the pages of "MORE PAPER MAGIC."

[Previous](#) | [Contents](#)