

## UNITED STATES PATENT OFFICE

2,042,934

## FIREARM

Merle A. Gill, Kansas City, Mo., assignor to  
Newton S. Hillyard, St. Joseph, Mo.

Application September 29, 1933, Serial No. 691,466

5 Claims. (Cl. 42-2)

My invention relates to firearms and more particularly to a device of that character to be supported in the palm of the hand and fired by closing of the fingers against a firing collar and has for its principal objects to provide a firearm of this type which is not liable to accidental discharge and that is automatically recocked after firing.

It is a further object of the invention to provide a firearm of this character for discharging tear gas shells.

In accomplishing these and other objects of the invention, I have provided improved details of structure, the preferred form of which is illustrated in the accompanying drawing, wherein:

Fig. 1 is a perspective view of a firearm embodying the features of my invention and showing the method of holding the device for firing a shell.

Fig. 2 is a perspective view of the parts of the device shown in disassembled spaced relation to better illustrate their construction.

Fig. 3 is a longitudinal section through the device showing a shell in position with the device cocked and ready for firing.

Fig. 4 is a similar view showing the firing pin in retracted position and about to be released by the automatic trip for firing the shell.

Fig. 5 is a cross section on the line 5-5, Fig. 3.

Fig. 6 is a perspective view of the firing pin latch.

Referring more in detail to the drawing:

1 designates a hand stock comprising a cylindrical body portion 2 provided with a substantially semi-spherical end 3 adapted to seat in the palm of the hand. The opposite end of the stock is provided with a cylindrical bore 4 terminating in a reduced internally threaded socket 5 to mount a firing pin guide tube 6.

The firing pin tube 6 includes a sleeve having an externally threaded end 7 to engage in the threaded socket 5. The opposite end of the guide projects beyond the open end of the stock and is provided with internal threads 8 terminating in a stop shoulder 9 formed by the reduced bore 10 of the sleeve. The guide member is also provided substantially midway of its length with a rectangular slot 11 of sufficient length and width to accommodate the firing pin latch, as later described.

The firing pin is designated 12 and includes a cylindrical body portion 13 of suitable diameter to be snugly slidable in the bore 10 of the guide.

The rear end of the pin 12 is provided with a spring socket 14 to receive one end of the firing pin spring 15 which has its other end housed within the guide and engaging against the bottom of the socket 5 to urge the pin toward firing position. The forward end of the pin is reduced in diameter to form a point 16 for firing a shell 17.

The periphery of the body portion of the pin is also provided with an annular groove 18 forming a keeper or latch shoulder in which a latch 19 engages when the firing pin is cocked.

Threaded into the outer end of the firing pin guide tube and engaging against the shoulder 9 is a breech block 20 having a cup shaped recess 21 at its rear end and a flat forward face or seat 22 against which the base 23 of the shell abuts. The breech block is also provided with a central axial opening 24 to permit projection of the point of the firing pin therethrough, as shown in Fig. 3.

The firing barrel 25 of the device is of substantially the same outer diameter as the outer diameter of the firing pin guide and its inner diameter is of suitable bore to accommodate the size of shell 17 to be used therein. The breech end 26 of the barrel is reduced in diameter and externally threaded as at 27 to be mounted in the threads of the firing tube and is of sufficient length so that when the end face 28 thereof engages the rim 29 of the shell the opposite side of the rim is clamped tightly against the flat face 22 of the breech block and the shoulder 30 formed by the reduced breech is tightly engaged with the end of the firing pin tube.

In order to move the firing pin into retractive position, I provide a firing collar 31 which is slidably mounted on the guide and has its rear end slidable within the bore 4 of the stock 1, as now to be described.

The member 31 comprises a cylindrical sleeve 32 of slightly less diameter than the diameter of the bore 4 and has its ends provided with internally extending flanges 33 and 34 to slidably bear upon the rear end of the barrel 25 and firing pin guide tube 6 respectively and whereby the sleeve is spaced therefrom to form a housing for the spring latch 19. The firing collar is normally retained in projected position relatively to the stock by a coiled spring 35 sleeved over the guide and having one end engaging the bottom of the bore 4 and its opposite end the flange 34.

The latch 19 is formed of flat spring metal having a flat body portion 36 terminating in a rearwardly extending tongue 37 having a down-

wardly curved end 38 operable in the slot 11 and adapted to engage an inclined end 39 of the slot to effect release of a firing pin, as later described. Formed integrally with the body portion of the

5 latch at opposite sides of the tongue 37 are inwardly extending ears 40 and 41 adapted to engage in the groove 18 formed in the firing pin when the firing pin is in projected position.

10 The latch spring is retained in position within the firing collar by fastening devices extending through an opening 42 in the collar and through an opening 43 in the spring and is retained in parallel relation with the axis of the guide tube by the ears 40 and 41 and the curved portion of

15 the tongue which extend into the slot for engaging with the periphery of the firing pin.

In assembling a device constructed as described, the firing pin guide tube 6 is screwed in the socket 5 of the hand stock. The firing pin

20 spring 15 and the firing pin 12 are then sleeved within the tube guide. The breech block 20 is then threaded into the open end of the tube until it seats against the shoulder 9.

The cocking spring 35 and the firing collar are

25 then sleeved over the guide tube so that the rear ends thereof enter within the open end of the hand stock, whereupon the ears 40 and 41 drop into the slotted opening 11 in the tube and enter the annular recess in the firing pin. The ears

30 then latch the firing collar against tension of the spring 35 since they engage with the end 44 of the slot 11 opposite the inclined end 39, previously described.

A shell 17 is inserted into the breech of the

35 barrel 25 so that the rim 29 thereof seats against the breech. The barrel is then screwed into the end of the firing pin guide tube until the base of the shell engages the breech block. The firing

40 arm is then cocked, loaded and in condition for firing.

To fire the shell, the device is held in the hand with the stock engaging the palm thereof and the barrel extending between the fingers, as

45 shown in Fig. 1. The fingers are then drawn back against the firing collar to move it retractively within the bore of the hand stock.

Since the ears 40 and 41 are seated in the

50 groove 18 in the firing pin, the firing pin will also be moved retractively against the tension of its spring 15 until the curved end 38 engages the inclined end 39 of the slot. Additional movement of the sleeve then causes the tongue to be cammed upwardly against the tension of the latch spring to withdraw the ears 40 and 41 from the annular

55 recess 18 of the firing pin so that the firing pin is released and driven by the stored up tension of the firing pin spring against the firing center of the shell 17 to explode the shell.

60 Upon release of the fingers from the firing collar the cocking spring 34 returns the collar to normal position and restores the ears 38 and 39 to engagement with the recess of the firing pin to again couple the collar therewith so that the device is

65 in position for firing upon retraction of the collar, as above described.

A new shell may then be inserted by removing the barrel, inserting the shell in the barrel and

70 replacing the barrel in the end of the firing pin tube, as above described.

The firearm is then loaded and ready cocked so that when the device is to be used the shell

75 may be fired simply by retracting the firing collar against tension of the spring.

It is thus apparent that since the device is automatically cocked after each firing operation, it is not necessary to cock the firing collar prior to retraction of the firing pin.

It is also apparent that due to resistance of the

5 spring 34, the firing collar cannot be accidentally moved to firing position. While a firearm constructed and assembled as described is adapted for use in firing various types of shells, it is particularly adaptable for firing a

10 tear gas or similar shell and there is no danger of accidentally discharging the gas when the firearm is carried in the pocket of the owner. If the device is to be used for firing tear gas shells only, it may be desirable to prevent its use

15 for firing a bullet, and in this instance, a pin 46 is inserted transversely of the bore of the barrel to preclude such use, otherwise the pin will be eliminated.

20 What I claim and desire to secure by Letters Patent is:

1. In a device of the character described, a hand stock provided with a tubular socket and having a threaded recess forming an annular

25 shoulder with the bottom of the socket, a firing pin guide tube having a threaded end engaging in said threaded recess of the hand stock, a barrel member carried by the outer end of the guide tube, a firing pin slidable in the guide tube,

30 a spring in the guide tube for urging the firing pin to firing position, a sleeve member having an imperforate annular wall slidable over the guide tube and barrel member and having one end

35 slidable within the socket of the hand stock, latch means within and completely enclosed by said sleeve member for engaging the firing pin to move the firing pin when the sleeve member is moved

40 retractively on the guide tube, a spring sleeved on the guide tube and having one end engaging said annular shoulder and its other end engaging the sleeve member to normally retain the latch

45 means in engagement with the firing pin, cam means on the guide tube for releasing the latch means when the sleeve member is moved within said socket against tension of the spring that is

50 sleeved on the guide tube, and a breech block mounted in the guide tube and cooperating with the barrel for retaining a shell in firing position in the barrel.

2. In a device of the character described, a firing pin guide tube, a hand stock provided with a tubular socket of larger diameter than the guide

55 tube, means securing the guide tube concentrically within the bottom of the socket, a firing pin slidable in the guide tube, a firing sleeve having an imperforate annular wall movable over the

60 guide tube and within said socket of the hand stock, latch means completely enclosed within the firing sleeve for normally connecting the firing sleeve with the firing pin to move the firing pin

65 when the firing sleeve is moved in one direction, means on the guide tube for releasing the latch means, a spring in the guide tube for urging the firing pin to firing position when released by the latch means, and a spring sleeved on the tube

70 for moving the firing sleeve to effect reengagement of the latch means.

3. In a device of the character described, a firing pin guide tube, a barrel cooperating with the firing pin guide tube, a hand stock supporting

75 the guide tube and provided with a tubular portion, a firing pin slidable in the guide tube, a firing pin spring in the guide tube having one end engaging the firing pin to urge the firing pin to firing position, a sleeve member having an imper-

forate annular wall snugly slidable within the tubular portion of the hand stock and having inwardly extending annular end flanges slidable respectively upon said guide tube and barrel, 5  
 latch means fixed within and completely enclosed by the sleeve member for connecting the firing pin with the sleeve member to effect compression of the firing pin spring when the sleeve member is moved toward the hand stock, means associated 10  
 with said guide tube to effect release of said latch means, and means for automatically returning the sleeve member for effecting reengagement of the firing pin.

4. In a device of the character described, a firing pin guide tube having a slotted opening therein, a hand stock supporting the guide tube and having a tubular portion, a firing pin slidable in the guide tube and having an annular recess therein in registry with said slotted opening, a firing pin spring in the guide tube for urging the firing pin to firing position, a sleeve member having an imperforate annular wall snugly slidable within the tubular portion of the hand stock and having inwardly extending annular 20  
 flanges cooperating with the imperforate wall to completely cover the slotted opening in the guide tube, a latch member fixed to and enclosed within the sleeve member and having an ear extend-

ing through said slot for engaging the recess and having a tongue for engaging the guide tube to release said ear from the recess when the sleeve is moved in one direction over the hand stock to cause the firing pin spring to move the firing pin to firing position, and a spring sleeved on the guide tube and having its ends respectively engaging the hand stock and sleeve member for returning the sleeve member to reengage the lip member with the firing pin. 5  
 10

5. In a device of the character described, a hand stock having a tubular socket, a firing pin guide tube fixed concentrically within the socket, a barrel member connected in axial alignment with the guide tube, a firing pin slidable in the guide tube, a firing pin spring housed within the guide tube for normally urging the firing pin to firing position, a firing sleeve snugly slidable within the tubular socket of the hand stock and having an annular gripping portion snugly slidable upon the barrel member, latching means completely enclosed within the sleeve member for releasably actuating the firing pin upon movement of the firing sleeve to load said firing pin spring, and a firing sleeve spring housed within the socket of the hand stock for returning the firing sleeve. 15  
 20  
 25

MERLE A. GILL.

June 2, 1936.

M. A. GILL

2,042,934

FIG. 1

Filed Sept. 29, 1933

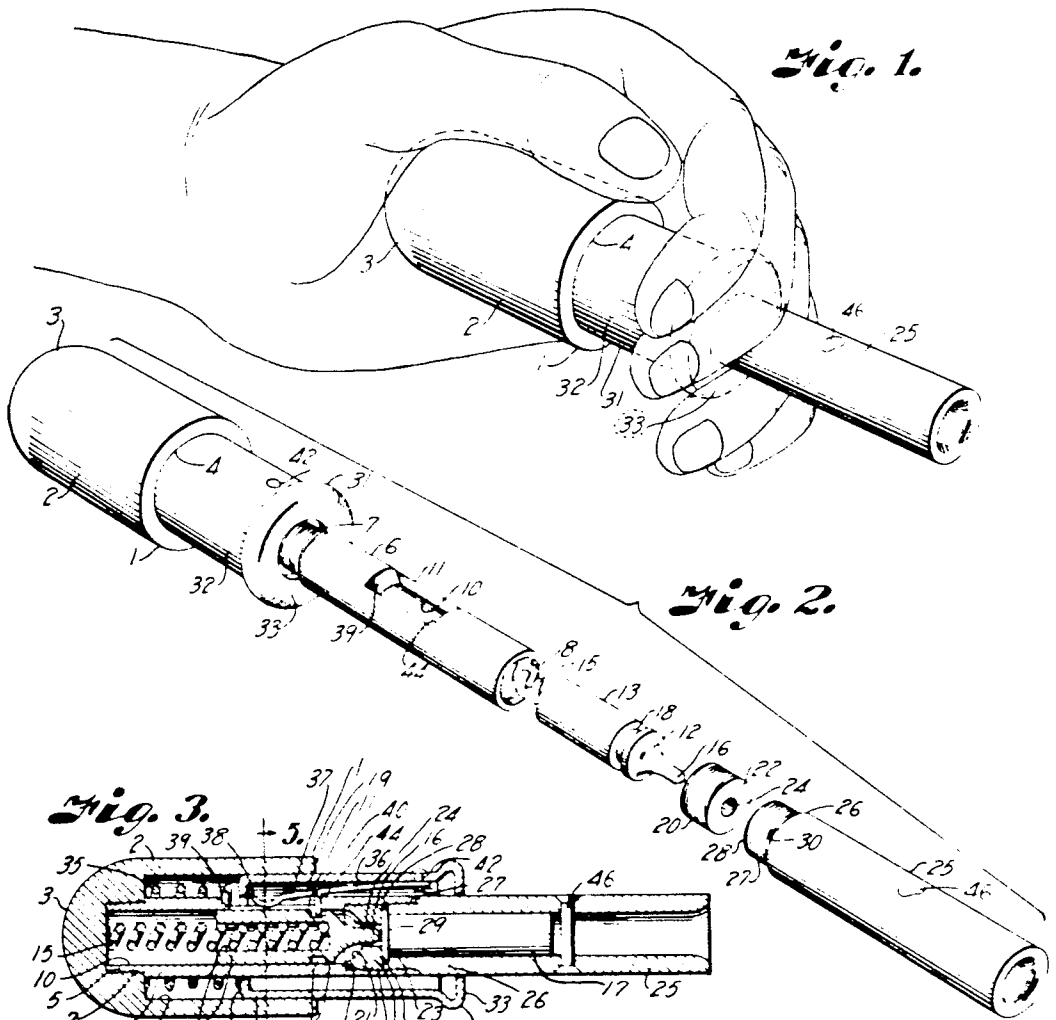

*Fig. 1.*

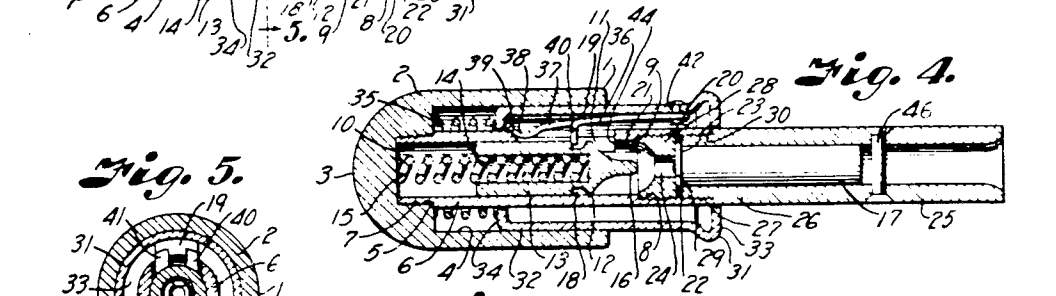

*Fig. 2.*

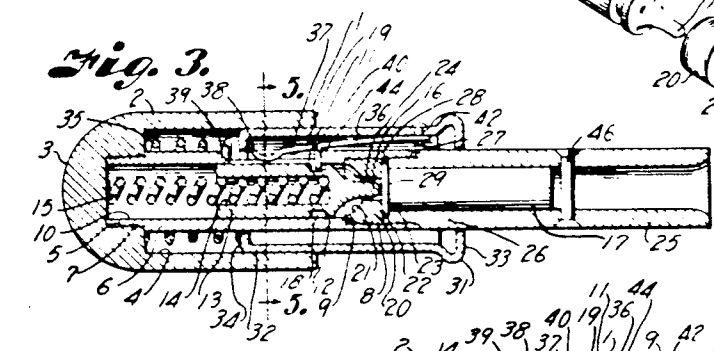

*Fig. 3.*

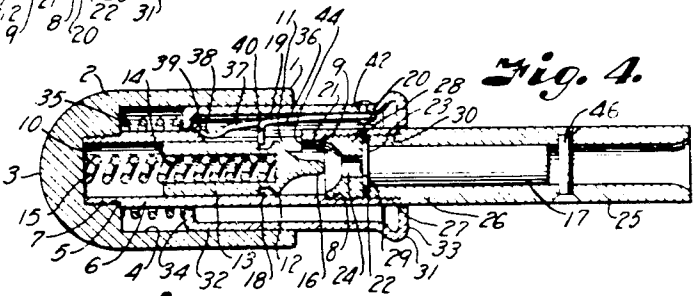

*Fig. 4.*

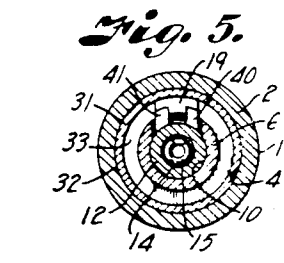

*Fig. 5.*

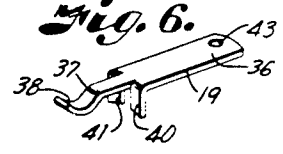

*Fig. 6.*

INVENTOR  
 Merle A Gill  
 BY *Wm. B. Bone*  
 ATTORNEY