

[54] **GAS-OPERATED MULTIPLE SHOT PROJECTILE FIRING DEVICE**

[75] Inventor: **Harold C. Palmer**, Douglasville, Ga.

[73] Assignee: **Palmer Chemical & Equipment Company, Inc.**, Douglasville, Ga.

[22] Filed: **Oct. 28, 1970**

[21] Appl. No.: **84,854**

[52] U.S. Cl. **124/11 R, 124/48, 42/59**

[51] Int. Cl. **F41b 11/06, F41f 1/04, F41c 21/00**

[58] Field of Search **124/11, 13 A, 48, 124/27; 42/59**

3,212,489	10/1965	Merz	124/48 X
2,625,927	1/1953	Rosenbloom	124/48 X
3,502,061	3/1970	Yoo	124/48 X

Primary Examiner—Richard C. Pinkham

Assistant Examiner—R. T. Stouffer

Attorney—Newton, Hopkins & Ormsby

[57] **ABSTRACT**

A gas-operated multiple shot projectile firing device with a circular and rotatable magazine which includes a plurality of chambers, each of which holds a dart-like projectile. A lever is associated with the projectile device and performs the dual function of cocking the firing mechanism and rotating the dart-filled magazine such that a plurality of projectiles can be successively fired upon a single loading. The device is particularly suited for short range firing and may be designed for dart projectiles of various calibers.

7 Claims, 7 Drawing Figures

[56] **References Cited**

UNITED STATES PATENTS

36,505	9/1862	Brand	42/59
3,397,476	8/1968	Weber	124/11 X
3,009,453	11/1961	Ayala	124/48 X

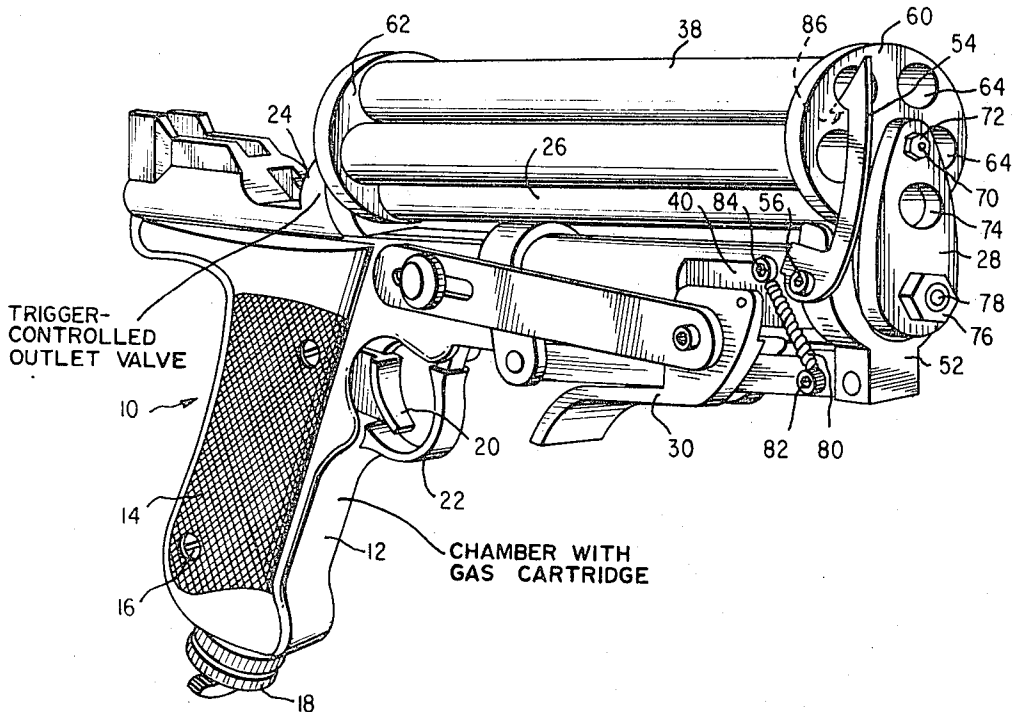

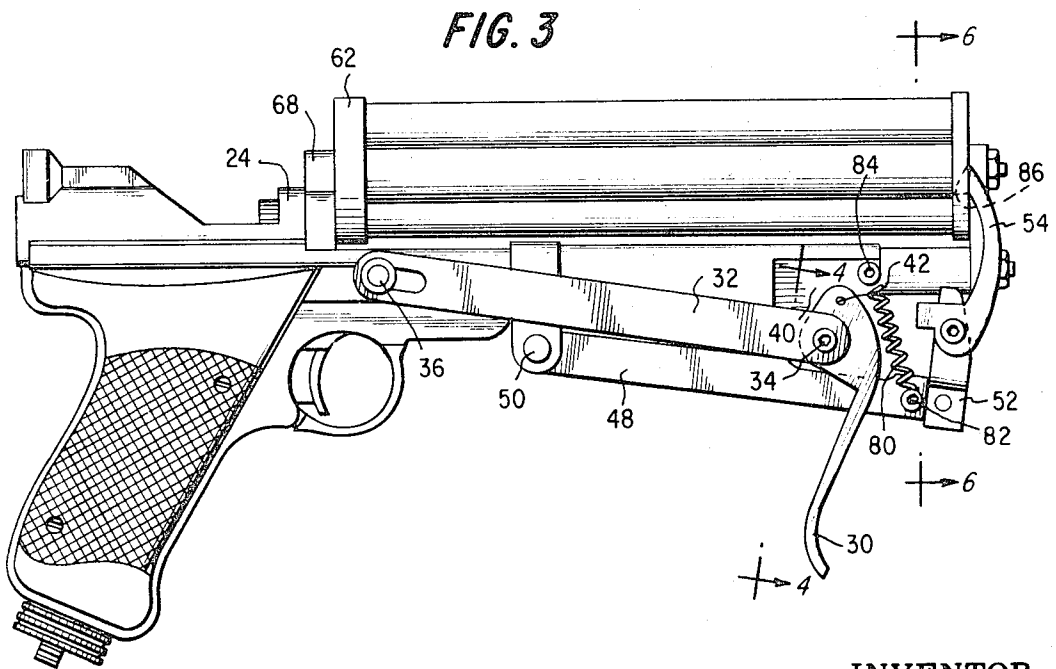
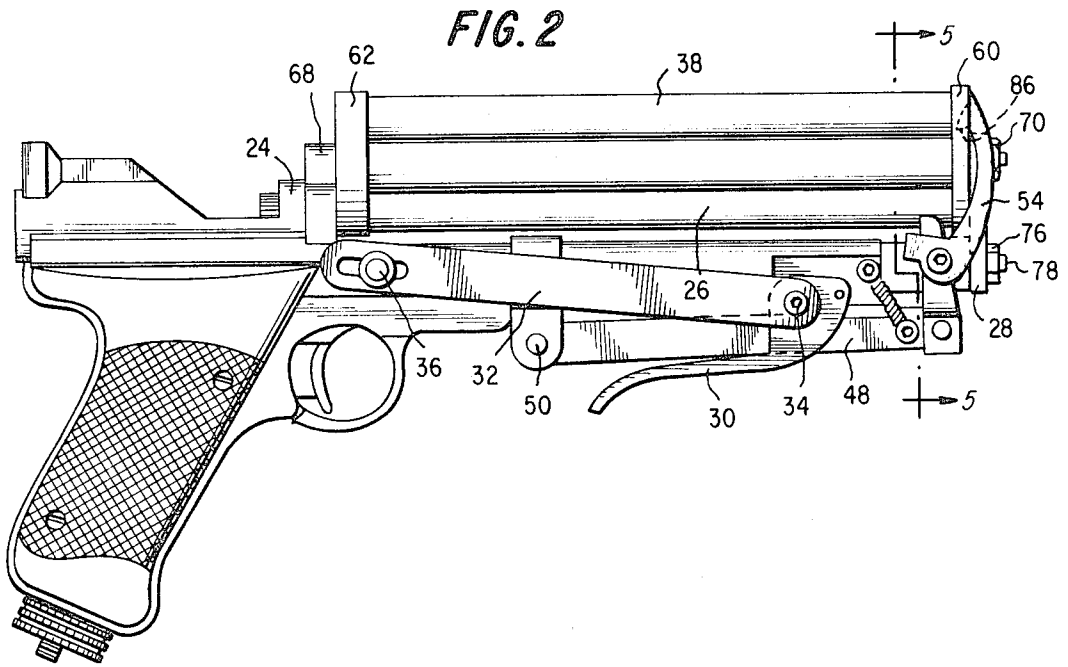

INVENTOR
HAROLD C. PALMER
BY *Newton, Hopkins, & Company*
ATTORNEYS

GAS-OPERATED MULTIPLE SHOT PROJECTILE FIRING DEVICE

BACKGROUND OF THE INVENTION

This invention relates to projectile firing devices in general and more particularly to a projectile firing device having a rotatable circular magazine which is adapted to hold and fire a plurality of dart type projectiles.

One need for a device which can fire dart type projectiles is as an aid in law enforcement activities. For example, a pistol which is capable of firing a dart containing teargas may be used as an effective agent for dispersing a riotous crowd. A dart containing a dye may be fired and used for making a rapid identification of an individual located in the riotous crowd.

These projectile darts may be fired by any suitable weapon such as, for example, a rifle or a pistol that is designed to provide propulsive power in the form of expanding gases, which by means of an expansion chamber and valve means are capable of controlling the gaseous discharge rate into the magazine area in which the projectile is situated. In one particular application, it has been found that a dart projectile of 0.50 caliber is satisfactory since the darts must be of sufficient size to carry an effective quantity of dye or teargas.

Another need for a device which can fire dart type projectiles is for the dispensing of a liquid dye provided within the projectiles and dispersed upon impact with an animal.

While dart type projectiles of the class described have been used in law enforcement activities and for animal control, as referred to above, it has been found that reloading of the prior art single shot type device after each discharge is extremely time-consuming. In the event the user misses with his first shot or needs subsequent shots, the single shot device is inadequate. For example, it would be impossible to disperse a large crowd or to rapidly mark a number of animals in a herd if the shooter had to reload after each firing.

The present invention is intended to solve the problem of a single shot capability in devices which fire material-filled dart projectiles by providing a projecting device in which several rounds of projectiles may be initially loaded into a rotatable magazine so that the same may be successively discharged without reloading.

SUMMARY OF THE INVENTION

Accordingly, it is an object of the present invention to provide a projecting device which is capable of launching a plurality of dart-like projectiles in a single loading.

Another object of the present invention is to provide a unique projecting device which is designed to fire a material-filled projectile by the use of propulsive power in the form of expanding gases.

Still another object of this invention is to provide a new and improved projectile firing device having a magazine for holding a plurality of dart-like projectiles and adapted so that the projectiles may be fired in rapid succession.

A still further object of this invention is to provide a unique gun having a magazine containing dart projectiles therein and which is adapted to be rotated, either manually or automatically, after each projectile

discharge so that unfired projectiles may be successively aligned with the firing chamber.

One other object of the subject invention is to provide a new and improved mechanism whereby alignment of successive projectiles along the firing axis of a gun during discharge is assured.

According to the present invention, the foregoing and other objects are obtained by providing a piston which is adapted to successively fire a plurality of large caliber dart-like projectiles by utilization of compressed gas. In particular, the pistol includes a projectile-holding magazine consisting of a plurality of large caliber dart holding tubes provided in parallel relationship with the firing axis thereof. The tubes are placed on the periphery of the magazine and are aligned such that as the magazine is rotated, each of the individual large caliber tubes comes into alignment and becomes coextensive with the firing axis of the pistol. Moreover, a cocking lever is provided which serves the dual function of indexing an unfired projectile filled chamber into firing position, while at the same time cocking the trigger mechanism. This enables the user to fire several shots in a rapid succession in a single loading.

BRIEF DESCRIPTION OF THE DRAWINGS

FIG. 1 is a perspective view of a multi-shot pistol for use in firing a dart-type projectile in accordance with the present invention.

FIG. 2 is a side view of the pistol of FIG. 1 in the cocked position.

FIG. 3 is a side view of the pistol of FIG. 1 during the cocking and indexing operation thereof.

FIG. 4 is a section-in-part view of the lever-frame connections at the front portion of the pistol of FIG. 1.

FIG. 5 is a section-in-part view of the magazine and yoke assembly of the pistol as shown in FIG. 2.

FIG. 6 is a section-in-part view of the magazine and yoke assembly of the pistol as shown in FIG. 3.

FIG. 7 is a cross-sectional view of the yoke and pawl connection of the pistol of FIG. 1.

DETAILED DESCRIPTION OF AN EXEMPLARY EMBODIMENT

Referring now to FIG. 1 of the drawings the multi-shot pistol shown therein has a conventional hand grip portion 12 which is designed so that the gun may be easily gripped and discharged by a user. The hand grip 12 may contain side plates 14 for increased aesthetic value, and the same may be made of plastic or the like so as to provide a surface which is easily gripped. The side panels 14 are secured to the hand grip 12 by screws 16. A closure cap 18 is threadably engaged to the bottom of the hand grip 12 for the purpose of securing a propulsive power source therein, such, for example, as a compressed gas cartridge. Still referring to FIG. 1, a trigger 20 and a trigger guard 22 of standard construction are provided to actuate the compressed gas firing mechanism when a projectile is discharged. The trigger 20 and trigger guard 22 may be made of any suitable material such as, for example, aluminum, steel, or a sturdy plastic substance. Upon actuation of the trigger 20, gas will be released from the compressed gas cartridge located within the hand grip 12 and will be directed into a gas expansion chamber indicated generally by 24. The expanding gas is then vented by a

conventional trigger actuated valve (not shown) into a tube chamber 26 which contains the projectile to be fired. The resulting force produced by the gas will thereby fire a projectile through an aperture 74 positioned upon an end plate 28 when the trigger 20 is actuated.

Referring now to FIGS. 2 and 3, there is shown that when it is desired to cock the hand pistol so as to advance a successive dart a lever 30 is either manually or automatically pulled to a substantially vertical position such as shown in FIG. 3. The force exerted by the actuation of lever 30 performs two functions. First, upon downward actuation, a sliding cocking bar 32 is pulled to the right by virtue of its threaded pin connection to lever 30 at 34. This movement of the bar 32 to the right will force a cocking knob 36 to go from the uncocked position as shown in FIG. 3 to the cocked position as shown in FIG. 2. As can be seen in both FIGS. 2 and 3, the connection between bar 32 and cocking knob 36 is a lost motion connection. Herein the lost motion connection comprises the cocking knob and the slot on the cocking bar wherein the knob is slidable. The second function performed by the actuation of the cocking lever 30 is that of indexing a rotary magazine 38 into a new firing alignment with the gas discharge expansion chamber 24. It should be understood that the lever 30 is pivotally attached to a frame 40 by a pin connection 42, which may be seen more clearly in FIG. 4. Further, a roller 44 is rigidly connected by a pin 46 to cocking lever 30, whereupon actuation of the cocking lever 30 will place the roller 44 into rolling contact with an indexing bar 48. In particular, the rolling contact will force indexing bar 48 to pivot about a pin connection 50 in a downward direction. Additionally, a yoke 52 is fixedly attached by means of a rivet or other suitable attachment to the indexing bar 48 in a perpendicular relationship such that the arms of the yoke 52 will surround and be guided by the frame member 40. Attached to one of the arms of yoke 52 is an indexing pawl 54. Pawl 54 is pivotally attached to one of the arms of the yoke 52 by any suitable means such, for example, as by a threaded screw 56. Further, the pawl 54 may be spring biased into hooking engagement with the rotary magazine 38 by means of a compression spring 58 or other suitable biasing means as shown in FIG. 7.

Referring now again to FIGS. 1-3, the rotary magazine 38 is shown as including a series of tubular chambers 26 which are located circumferentially about connecting plates 60 and 62. Tubes 26 project through a plurality of apertures 64 located in the plates 60 and 62, such that there is a wedging relationship between the tubes 26 and the apertures 64. This arrangement may be more clearly seen by referring to FIGS. 5 and 6. In addition, the circular magazine 38 has a rotating axial pin 66 (as shown in FIGS. 5 and 6) which connects the center of the plate 60 to the center of the plate 62 and is adapted such that the pin 66 may be pivotally mounted between a plate 68 and a holding member 70 to the plate 28 by a nut 72 such that the magazine 38 may rotate freely. The plate 28 is further provided with apertures 74 which correspond to the diameter of tubes 26. Further, it should be understood that the plate 28 is secured to the frame 40 by pin and nut connections 78 and 76. Moreover, the indexing arm 48 is provided at 82 with spring biasing means 80

which is connected to the frame 40 so that after cocking and indexing is performed, the lever 30 will be biased back into its folded position.

In operation, the dart projectiles are inserted into each of the tubes 26 of the rotary dart magazine 38. The cocking lever 30 is then pulled downwardly and forwardly by the user. Accordingly, the cocking knob 36 and its associated mechanism will be cocked. At the same time, the roller 44 will force the cocking bar 48 to pivot downwardly, and thereby entrain the yoke 52 and the indexer 54. The indexer 54 has a hook 86 which engages one of the apertures of the end plate 60 and thereby draws the plate 60 downward in a rotary motion. This sequence may be more clearly seen by reference to FIGS. 2 and 3, and the respective cutaways in FIGS. 5 and 6. After full extension of the lever arm 30 is made, as shown in FIG. 3, the same is released and return spring 80 brings the mechanism back to its original position, as shown again in FIG. 2. The trigger mechanism is now cocked, and one of the tube chambers 26 is located in the firing axis with a projectile located therein in a condition ready for discharge. The above procedure may be repeated until all of the initially loaded projectiles are successively fired.

Obviously, many other modifications and variations of the invention are possible in the light of the above teachings. For example, while the magazine of the subject invention is shown as accommodating five dart type projectiles, the invention is not so limited and the magazine may be designed to accommodate any desired number of projectiles. It is therefore to be understood that within the scope of the appended claims, the invention may be practiced otherwise than as specifically described.

What is claimed as new and desired to be secured by Letters Patent of the United States is:

1. A multiple shot projectile firing device comprising a supporting means, a compressed gas cartridge supported by said supporting means, a gas expansion chamber mounted within said supporting means and provided with an outlet passage valve means for controlling the flow of gas from said cartridge to said outlet passage, a trigger connected with said valve and arranged so that, when pulled, it will open the valve and cause a charge of gas to be expelled through said outlet passage, a cocking device for said trigger, a magazine mounted on said support for rotation about a longitudinal axis and comprising a plurality of barrels spaced around and parallel to said axis, said magazine being so positioned that, as it is rotated about said axis, the inner end of each of the barrels will be successively brought into communication with said expansion chamber, a first lever pivotally mounted at one end on said supporting means and having a connection at its other end for rotating said magazine when the lever is moved about its pivot, a slidable cocking bar connected at one end with said cocking device, a second lever pivoted on said supporting means and pivotally connected with the other end of said cocking bar, said second lever being also connected with said first lever, the arrangement being such that movement of said second lever in one direction will operate the cocking device to cock the trigger and will simultaneously rotate the magazine about its axis through a distance sufficient to remove

5

6

one barrel from a position in which it communicates with said expansion chamber and to place a next adjacent barrel in such communicating position.

2. A device as in claim 1 wherein the connection between said cocking bar and said cocking device is a lost motion connection.

3. A device as in claim 2 wherein said lost motion connection comprises a knob on said cocking device and a slot in said cocking bar in which said knob is slidable.

4. A device as in claim 1 wherein the connection between said first and second levers comprises a roller mounted on said second lever and movable along said

first lever.

5. A device as in claim 4 wherein the connection between said first lever and said magazine comprises a yoke attached to said first lever and a pawl pivotally mounted on said yoke.

6. A device as in claim 5 wherein said pawl is successively engageable in the outer ends of said magazine barrels.

7. A device as in claim 6 wherein a spring is provided for returning said first lever to its initial position after movement by said second lever.

* * * * *

15

20

25

30

35

40

45

50

55

60

65