

The

CASELMAN

Homemade Air-Powered
Light Machine Gun



*The History,
My Quest,
And
the Complete Construction Plans*

On Guns Magazine, December 1991, page 93, "Gun Market Classifieds", "Survival", there was an advertisement:

"Awesome .30 cal. Air Machine Gun design, 30 shot clip, selective fire, 32 ACP power, hand held rifle size, detachable tank. For survival and defense. Don't be disarmed. Home built proven plans reveal system. \$ 19.95, with video \$ 59.95. Caselman Explorations, Box 348, Cameron, MO 64429".

Since that time I am after those “ Plans & Video” to no avail.

I advertised in several publications and websites, send messages to airguns collectors all over the World, also created Communities at Orkut.com about airguns to try to find information on this gun – to no avail.

In the early years of 21St. Century I managed to stay in contact with Mr. Jeff Caselman, the inventor of this amazing weapon.

We talked over the phone a few times, exchanged e-mails and fax notes, and he said to me that later he´ ll search for the original plans and send me a copy.

But since that day I can not found him anymore.

E-Mail changed, Phone disconnected, Letters returned – as if he vanished on thin air!

But I stay after those “ Plans & Video” to no avail - ´ till August, 2006.

In August 4th ., 2006, my dear good friend Dr. Robert Beeman (www.beemans.net) found a copy of the plans and send it to me as a gift.

Now, after 15 years and several thousand Dollars after the initial search, I am givin´ it for free to anyone who want to download it.

I hope that this humble contribution´ll help fight the crazy global war against legal firearms and civilian ownership of legal guns – this gun is an AIRGUN, not a firearm, but really awesome as a combat weapon and I´m sure anyone under infantry combat conditions on urban, jungle, or woods environments´ll find to be not undergunned.

Have fun, be safe, and never give away your FREEDOM.



Mad Abe - Brazil, August 2006.

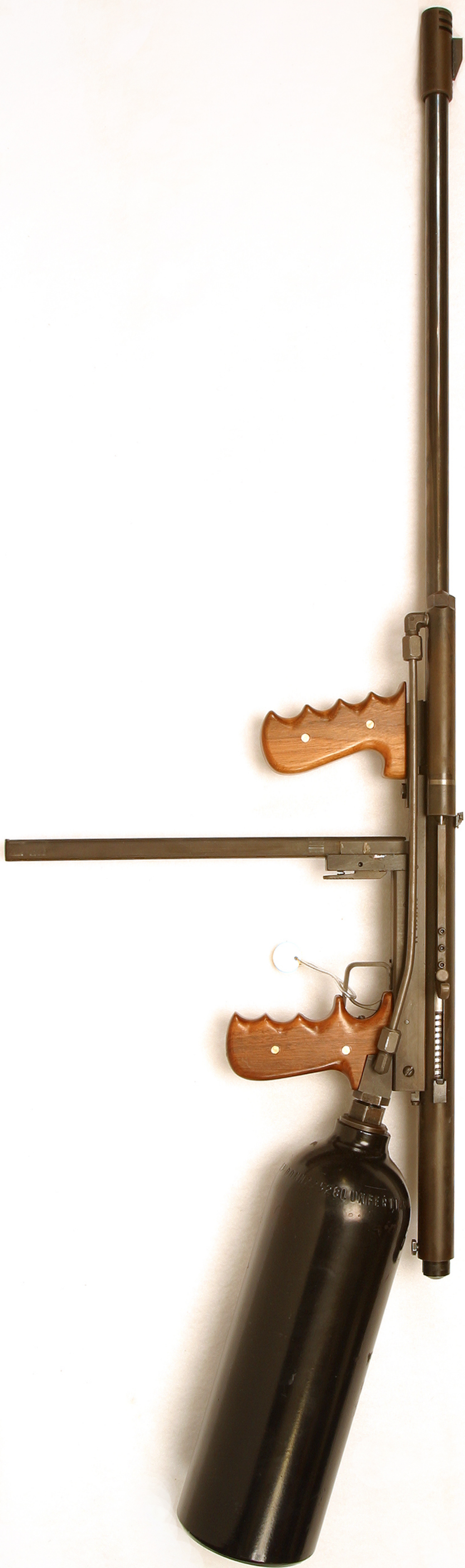

\$ 19.95

THE SHOP BUILT 30 CAL AIR MACHINE GUN

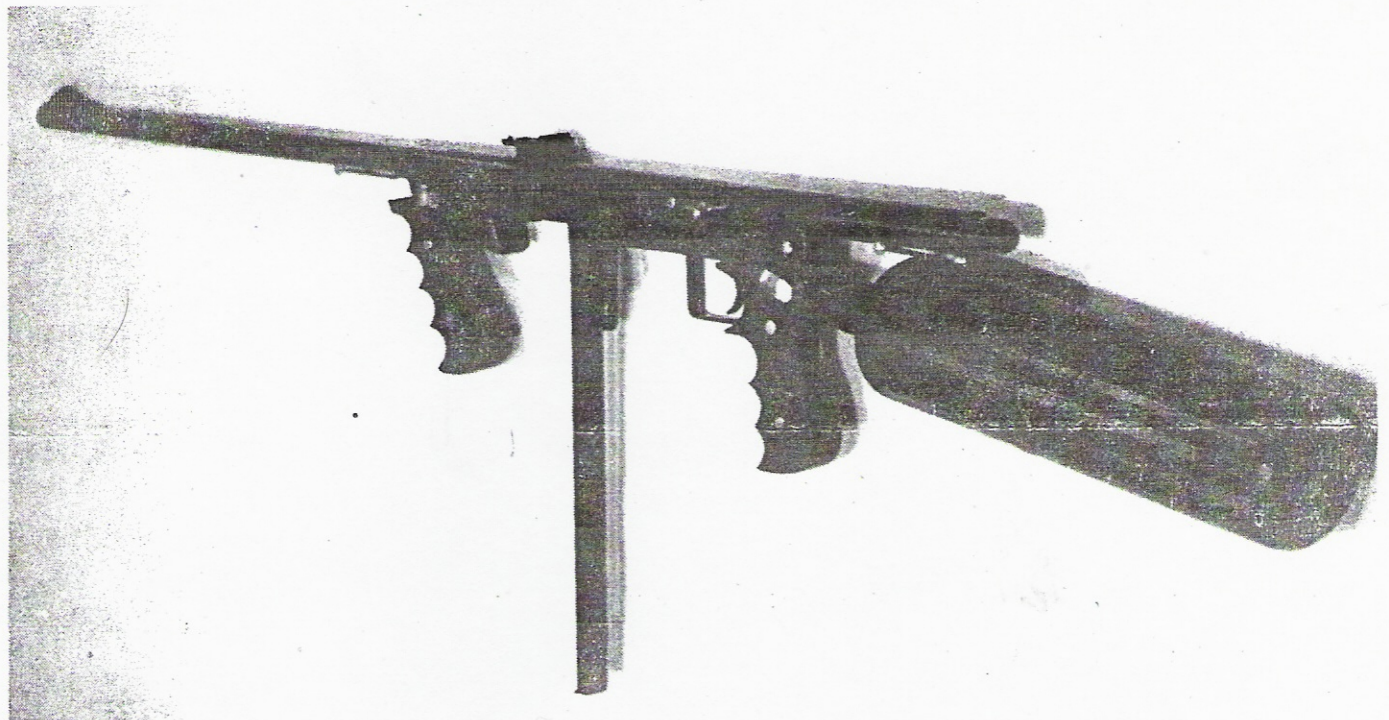

SELF SUFFICIENT
DELIVERS 32 ACP POWER
DESIGN - HAND HELD SELECTIVE FIRE AUTOMATIC
SYSTEM OF OPERATION - BLOW BACK
CALIBER - 30 (.311 BOTTOM GROOVE)
BARREL LENGTH - 20" to 24"
MAGAZINE CAPACITY - 30 BULLETS (85 to 100 gr.)
OVERALL LENGTH - APPROX. 45"
WEIGHT - 10 to 12 LBS.

BY CASELMAN EXPLORATIONS

THE 30 CAL. AIR MACHINE GUN
Copyright 1990 by Caselman Explorations
Printed in the United States of America

All rights reserved. No portion of this book may be reproduced in any form without the express written permission from Caselman Explorations. Direct all inquiries and or orders to the address listed below.

Caselman Explorations
P.O. Box 348
Cameron, Mo. 64429



Caselman Explorations assumes no responsibility for the use or misuse of the information contained in this book.

FOWARD

I started working on the concept of a high powered pneumatic rifle in 1979. (Although the idea started cooking as a young boy.) I started with a small lathe and just a few tools, located on a back porch shop. I've made a lot of progress, with added tooling, and a better plan.

PARTS LIST

CR-Cold Roll Steel
 MW-Music Wire
 O1-Oil Harden Tool Steel

1. Firing Valve-CR
2. Firing Valve Stem-Dowel Pin
3. Firing Valve Seat-Ultra high density plastic
4. Firing Valve Body-CR
5. Firing Valve Holding Area-CR
6. Firing Valve Spring-MW
7. Firing Valve Spring Guide-22 ga. CR
8. Firing Valve O Ring
9. Striker-O1 or CR
10. Cocking Pin-Concrete Nail etc.
11. Cocking Pin Retaining Roll Pin
12. Striker Screws 6-32
13. Striker Follower-D.O.M. Mechanical Tube
14. Striker Follower Sear-O1
15. Striker Spring-MW
16. Striker Buffer-Plastic
17. Bolt-O1 or CR
18. Bolt Body-D.O.M. Mechanical Tube
19. Bolt O Ring-5/16 by 3/16 by 1/16
20. Bolt Pins-3/32 Roll Pins 1/2 long
21. Bolt Spring-MW
22. Spring Follower-CR
23. Breech Plug-CR
24. Breech Plug Screw-1/4 28
25. Receiver-D.O.M. Mechanical Tube
26. Barrel-Select 311 Bottom Groove
27. Barrel Screw-1/4 28
28. Trigger Housing-1 by 1 1/8 by 1/8 Rectangular Tube
29. Trigger Housing Mounting Block Rear-CR
30. Trigger Housing Mounting Block Front-CR
31. Trigger Housing Screws-10-32
32. Trigger Guard-CR
33. Trigger-CR
34. Trigger Frame Block-CR
35. Trigger Stop Screw Adjust-10-32 by 1/2
36. Trigger Stop Screw Setnut-10-32
37. Trigger Pivot Pin-Dowel Pin 1/8 by 1
38. E-Clip Spacers
39. Trigger Spring-Torsion-MW
40. Full Auto Sear Trip-O1
41. Full Auto Sear Trip Pin-Dowel Pin 1/8 by 5/8
42. Full Auto Sear Trip Spacer-CR
43. Sear Spring-MW
44. Disconnecter-O1
45. Sear-O1
46. Sear Spring-MW
47. Sear Stop Screw & Set Nuts-6-32
48. Magazine Housing-CR
49. Magazine Release-CR
50. Magazine Release Pin-Dowel Pin 1/8 by 5/8
51. Magazine Release Spring-MW

PARTS LIST (CONT.)

52. Tank Mount Shader
53. Tank Mount - CR
54. Tank Mount O ring - 3/4 X 9/16 X 3/32
55. Tank Mount To Firing Valve Fittings
56. Airline - 1/4 X 3/16 Tube
57. Tank
58. Tank Valve - CR
59. Tank Valve O ring
60. Tank Valve Body - CR
61. Rear Grip Body - CR
62. Rear Grips - Plastic
63. Front Grip Body - CR
64. Front Grip Body Ring - Tube
65. Front Grip Body Strap - CR
66. Front Grips - Plastic
67. Grip Screws Male & Female
68. Magazine - CR
69. Magazine Rear Plate - CR
70. Magazine Bullet Holders Left & Right - 01
71. Magazine Follower - Plastic
72. Magazine Follower Spring - MW

CALIBER CHANGE FORMULA to shoot similar ballistic bullets. Select telescopic D.O.M. tubes for receiver, bolt and striker assembly for these approx. weights. Bolt weight ~~to~~ to ~~X~~ X bullet weight ~~←~~ ← 40X (varies with barrel length.) Striker assembly 85% of bolt weight. Cross section area through firing valve and its orifice should equal $\frac{1}{2}$ cross section of bore. Try to keep lengths approx. the same, however lay the action out to allow for a change in the distance the bolt moves before the O ring reaches the loading port, it should be approx. 2.4 X bore dia. Also increase & decrease striker spring tension with bore cross section.

RAW MATERIAL KITS - consists of the metals & tubes to be machined with one stamped magazine, less barrel, tank, springs, ect. ~~\$75.00~~

COMPLETE MACHINED KITS - unassembled fireable gun, less grip sculpturing, exterior finish, and tank. - P.O.R.

MAGAZINES - Stamped blanks \$7.50 - Complete magazine ~~\$50.00~~ P.O.R.

BULLET MOLDS - 2 cavity Lyman 85 gr. .311 \$45.00 - 2 cavity Lee 100 gr. .311 \$30.00

LIGHT WEIGHT TANKS - We are seeking a cost efficient supplier. P.O.R.

CONSTRUCTION & PERFORMANCE VIDEO - \$40.00

NEWSLETTER OF THINGS TO COME - Purchasers of plans will receive the latest information on our work and new products.

Prices subject to change without notice. Add \$5.00 shipping charge.

HOW THE GUN WORKS

This gun is a basic blow back system designed to operate from the peak pressure of a pre-pumped detachable tank of approx. 100 cubic in. capacity which is the shoulder stock.

The gun has a 30 round detachable magazine that when it snaps in the magazine housing releases all its bullets to flow freely into the loading port. The bullet mold was selected to cast a 1 in 40 parts tin bullet, that would strip off each other without hanging up.

Pressure drops slightly from shot to shot, but the valve tends to compensate for it some, as the valve is harder to strike open at higher pressure and lets more air out at lower pressure. A good polish of receiver tube ID., bolt & striker are very important because it takes over a 150 lb. blow to open the firing valve, which has to recock on momentum of the bolt.

Manual cocking is done by forcing the cocking pin on the striker into the bolt so it will come back with the striker. Upon letting go, the sear holds the striker, the cocking pin spring releases the bolt, letting it pick a bullet out of the loading port shoving it into the firing chamber past the air inlet from the firing valve. The bolt being in the proper place for firing allows the disconnecter to come forward by going into the small off-set slot in the bottom of the bolt body. This lets the disconnecter pull down the sear upon pulling the trigger letting the striker hit the firing valve. In the first stage of the trigger the striker follows lower will recoil with the bolt and hit the disconnecter releasing the sear, which establishes semi-auto fire, as you pull on down to the next stage the auto sear trip comes up to trip the sear for the next shot when the bolt comes home.

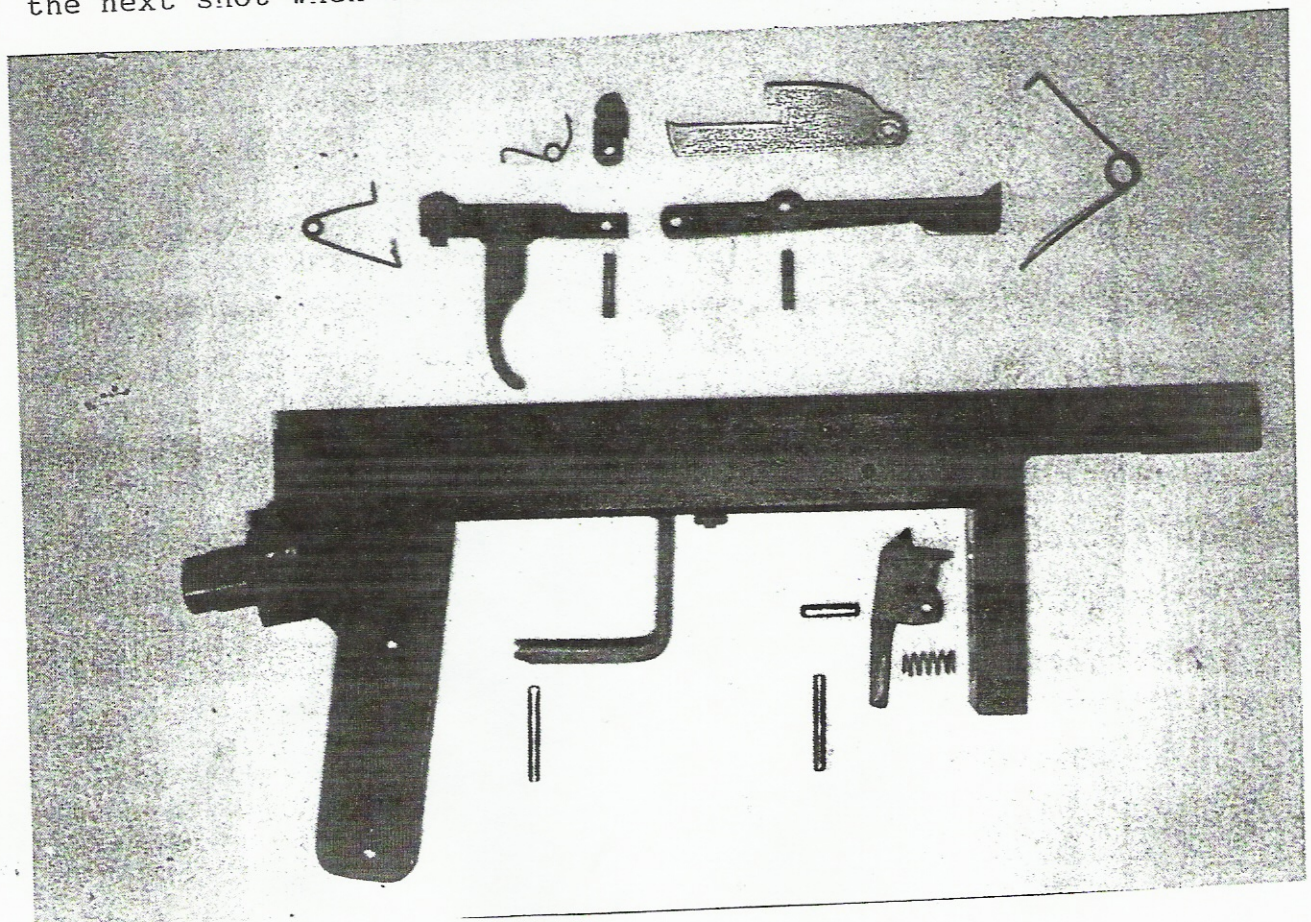

CONSTRUCTION TIPS

Drilling the firing valve outlet is done after welding it to the receiver. First place barrel in receiver in proper place. Drill and tap 1/4-28 hole 1/2 inch from front of receiver on the bottom, install allen screw to hold in place. Next mill out loading port and drill vent holes. Roll receiver 90 degrees and put 3/4 round bottom groove 1/16 deep for firing valve body, you also cut 3/4 round through barrel shoulder at same time. Now position and drill 7/32 hole for air inlet in receiver and halfway through barrel at same time. Pull out barrel and in same setting drill on through receiver. Next line up firing valve body and weld in place 3/4 inch welds top and bottom. Be careful not to weld to close to threads. Now firing valve can be drilled through receivers 7/32 holes. Next screw firing valve holding area on tight and locate hole for 1/8 NPT in the end of holding area so that it is down. This hole plums to the tank mount with 90 degree 1/8 NPT to 1/4 brake line fitting.

Making bolt start with 3/4 stock and locate where large dia. is, cut this area down .020 on lathe then build back up with brass over size (approx. ten-thousandths.) Turn down and polish .002 under receiver tube ID. Then finish bolt dimension. Cut O ring groove with 1/16 wide cutter with a nose radius of 1/32 go .060 deep.

Trigger housing is made out of rectangular tube with top milled off and cut to dimension. The front mount (part 30) is welded in place, flush with the front, with radius up. The rear mount screws under receiver at 9 3/16 & 9 11/16 with two shouldered 10-32 screws with front mount in place, put in front screw, this will locate 10-32 hole inside of rear mount through # 10 hole in trigger housing.

Study trigger and sear assembly before cutting out. Hand fit to your gun the relationship between the hook on the disconnecter with the sear, also the auto-sear trip with the bolt. If the disconnecter swings down to far before it hits the sear, just as the sear is going to catch the striker assembly, the downward movement of the disconnecter will knock the sear down, not catching the striker thus allowing the striker to be slowed down by the bolts function going home. The result, a weak strike on the firing valve. A small wedge of O1 tool steel may be added to sear above where the auto-sear trip sets to make the sear catch point 1/4 inch wide by brazing before hardening. The trigger assembly parts must be polished and allowed to move freely in trigger housing. E-clips may be used as spacers on trigger. The sear and full auto sear trip share center line in the trigger housing. The full auto sear trip sets on the left in the 1/8 inch slot, in the magazine housing.

CONSTRUCTION TIPS (CONT.)

The sear is held in place by a $\frac{3}{16}$ inch dowel pressed in the trigger housing with a $\frac{1}{4}$ inch long spacer holding it on its half of center line. A torsion spring wraps around the spacer made of .041 music wire with a $1\frac{3}{8}$ inch leg on the outside with a 90 degree bend $\frac{3}{8}$ long, On the floor of the trigger housing. On it's third revolution coming up, at approx. 90 degrees it extends $1\frac{5}{16}$ inches, 90 degrees away from the coil to hook under

CONSTRUCTION TIPS (CONT.)

The following springs were wound around there pin sizes in a vise, as tight as possible. They were formed with pliers and baked in the oven at 550 degrees to 625 for 35 to 45 minutes.

Compression springs were stretched around a mandrel. The lead screw was set for the pitch, made with closed and ground ends, then baked in oven.

The magazine spring was stretched around an oval bar 1/4 in. by 1/2 in. about 14 in. long at 1/4 pitch wound off by hand, then reset by hand with small pliers and baked. Note; Spring will crawl forward in oven.

The magazine was made by milling out a punch and dye with a 3/8 round end mill and a 5/32 radius corner rounding mill. After formed, spot braze together, and a 5/16 button forced through it with shims to insure proper inside dia. a.400 by 1/8 notches were cut in the sides of the opening for the lugs on the bullet holders to recess in, then braze on bullet holders 1 in. back from end. Allow a little clearance then heat to deep red (not bright,) Dip in oil then draw back to spring hard. Make catch assembly as shown in magazine follower, put spring in, then follower. This magazine will hold lead alloy bullets while loading and handling. When magazine locks in magazine housing the receiver spreads the bullet holders, letting the bullets flow freely into loading port. The magazine catch is cut into magazine by putting layout blue or black magic marker on magazine sliding it in magazine housing. The magazine release will scratch the blue and show where to cut retaining groove.

Tank selection is important. Be careful in finding or building a tank that it will handle the pressure. You may pressure test a tank with a port-a-power pump to 1000 over pressure required. This would be the safest way. Note part 53 that welds to trigger housing is milled off at an angle, so the tank will clear the receiver approx. a 10 degree angle. Our tank was 3 5/16 in. dia. by 13 3/8 long with 1/2 NPT fitting. If using a different size tank check layout for clearance and adjust angle for fit.

Tunning the weapon is done by adjusting the spring tension on the striker, at the breech block in the rear of the receiver, while maintaining just enough spring tension to force the bolt home. (Shimming the inside bolt spring may be necessary.) Lower pressures may require winding a softer striker spring.

The firing valve stem protrusion distance is critical, if it is to short it will not let out enough air. If it is to long it will cause excessive chamber pressure, which will shock load the magazine spring and collapse it. I suggest .125.

PRESSURE & PERFORMANCE

There are many sources of air. Dive shops, divers tanks, small DC compressors from military surplus, aircraft strut pumps and shop built hand and motor driven, two & three stage pumps.

A good starting pressure is 3000 lbs., although I am sure the gun will operate as low as 1000 lbs. with some tuning. Keep in mind that liquid CO₂ is 1000 lbs. at 83 degrees, and as long as there is a liquid portion in the tank the pressure would remain the same at that temperature. This would give several hundred shots per tank and it could be filled from a fire extinguisher.

Our velocity formula is $V = \sqrt{ZAD}$. Take the cross section of the .311 bore (.0759) by the air pressure (3000) = 2277 X the # of 100 gr. bullets per lb. (70) = 15939 gives acceleration in g's X 32.2 = 513235.8 X twice the barrel length in feet (4) $\sqrt{2052943.2}$ equals 1432.8 ideal velocity.

Our goal is to operate 70% efficient which would give 1000 fps.

TROUBLE SHOOTING

1. Weapon Won't Recoil
 - A. To much spring tension
 - B. Weak strike on valve
 - C. Striker or bolt assembly binding
2. Quits Firing After Weak Second Shot
 - A. Sear not catching striker
 - B. Spring tension wrong
3. Jamming
 - A. Check allignment of magazine to loading port
 - B. Spring to weak in magazine
 - C. Bad bullet design
 - D. Bullet to soft
 - E. Need radius from loading port to bore axis & polished
4. Semi-Auto Function Fails
 - A. Sear binding or lack of upward tension
 - B. Trigger spring to weak
 - C. Disconnecter to sear relationship off
5. Excessive Loading Port Pressure
 - A. Sear binding or lack of upward tension
 - B. Bullets to hard
 - C. Valve stem to long
6. Low Power
 - A. Weak strike on valve
 - B. Valve stem to short
 - C. Binding in striker assembly
 - D. Barrel needs lapped
 - E. Bolt O ring blown

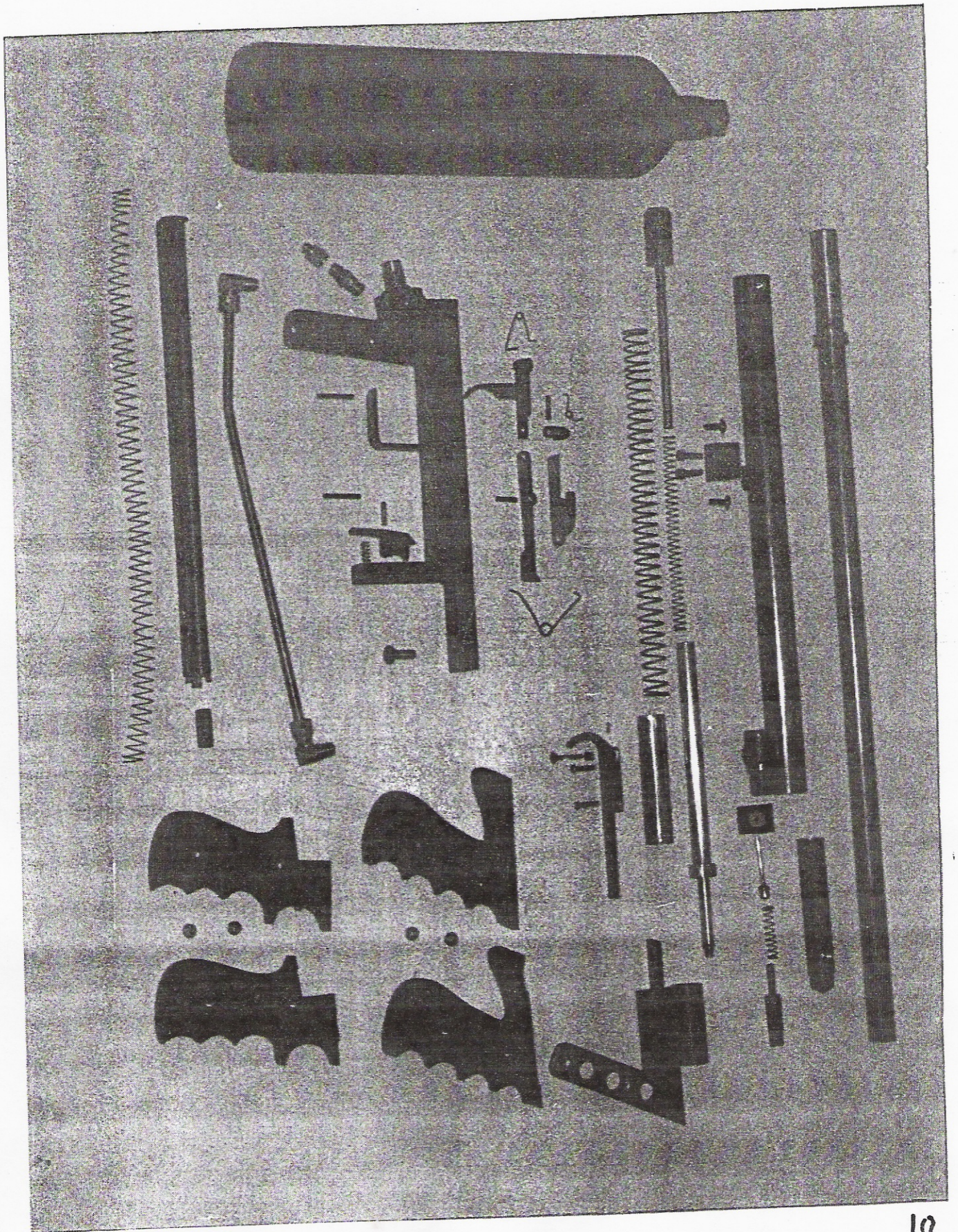

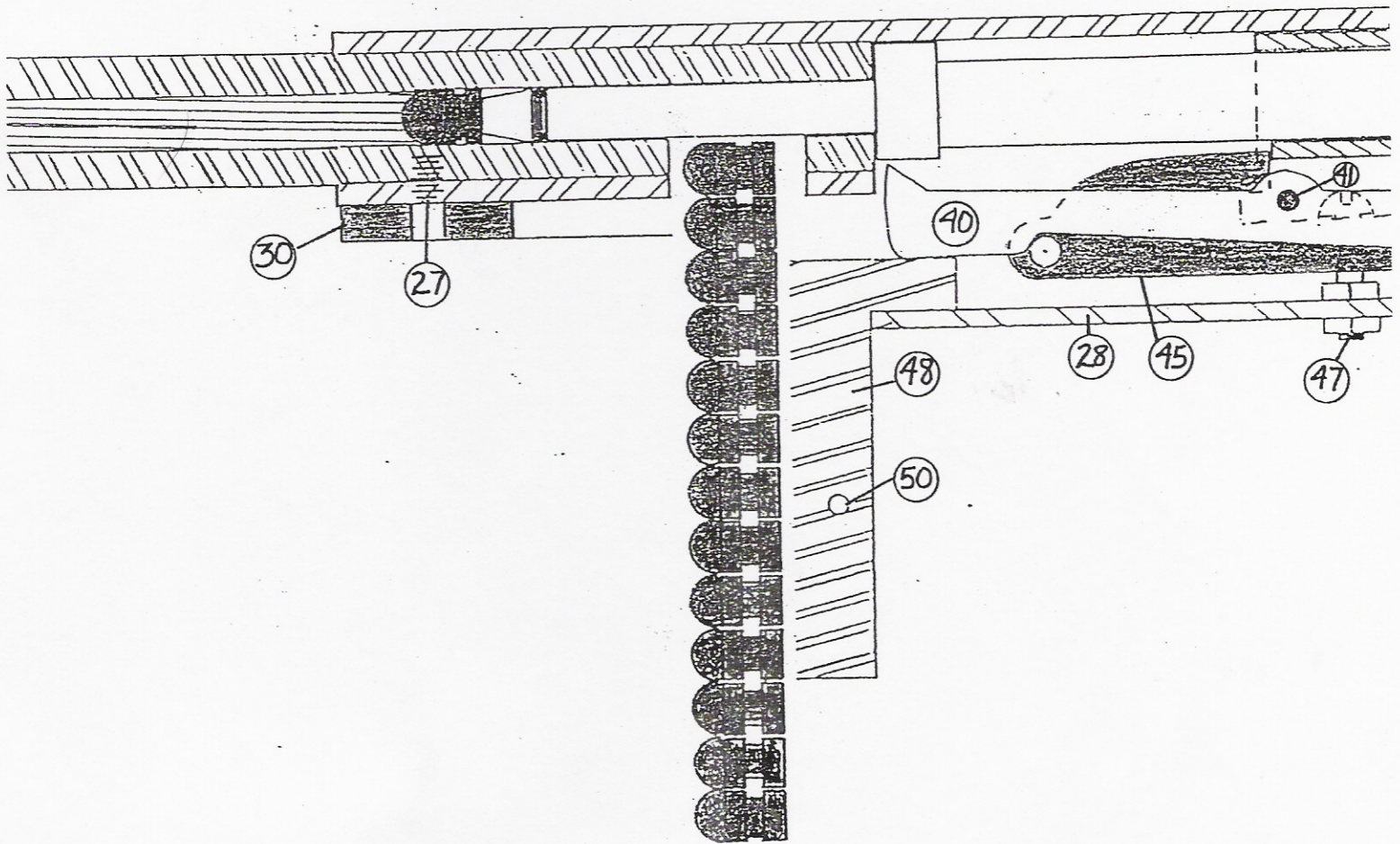
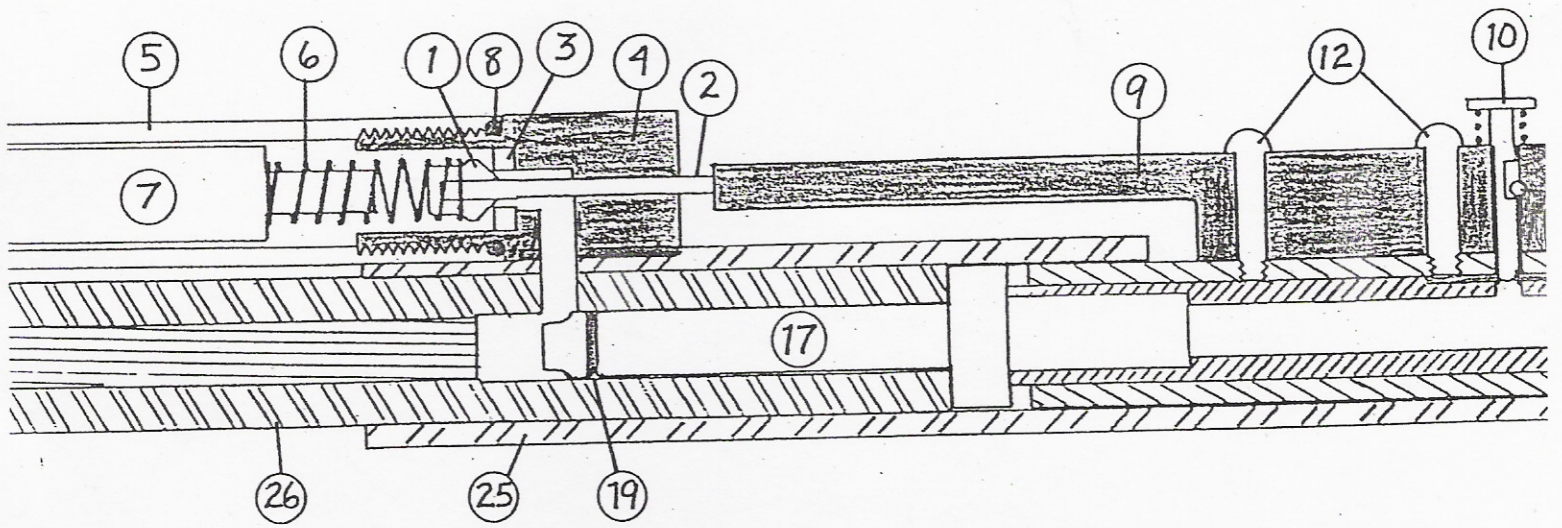

Cocking Pin must slide freely in bolt body slot
Press in to pull bolt back

Bottom view

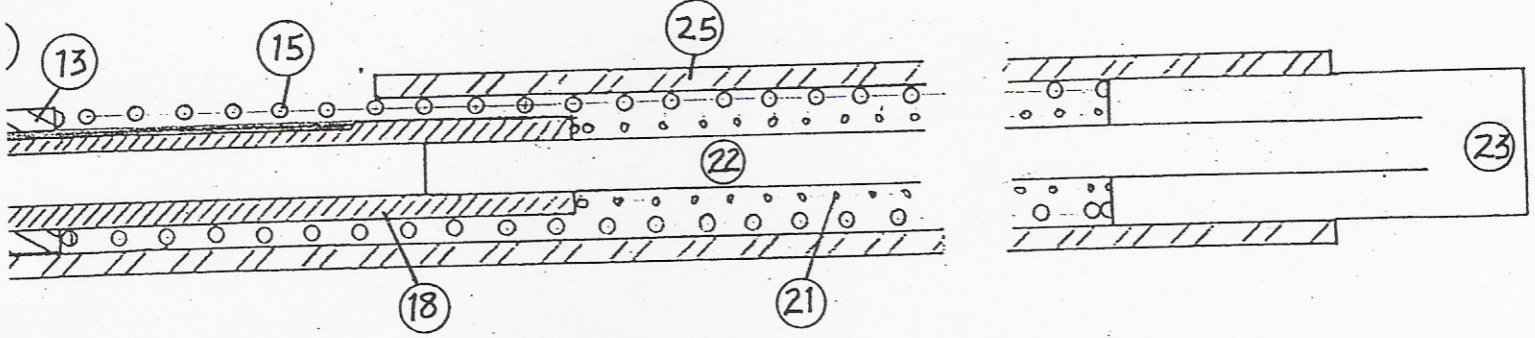

Left side view

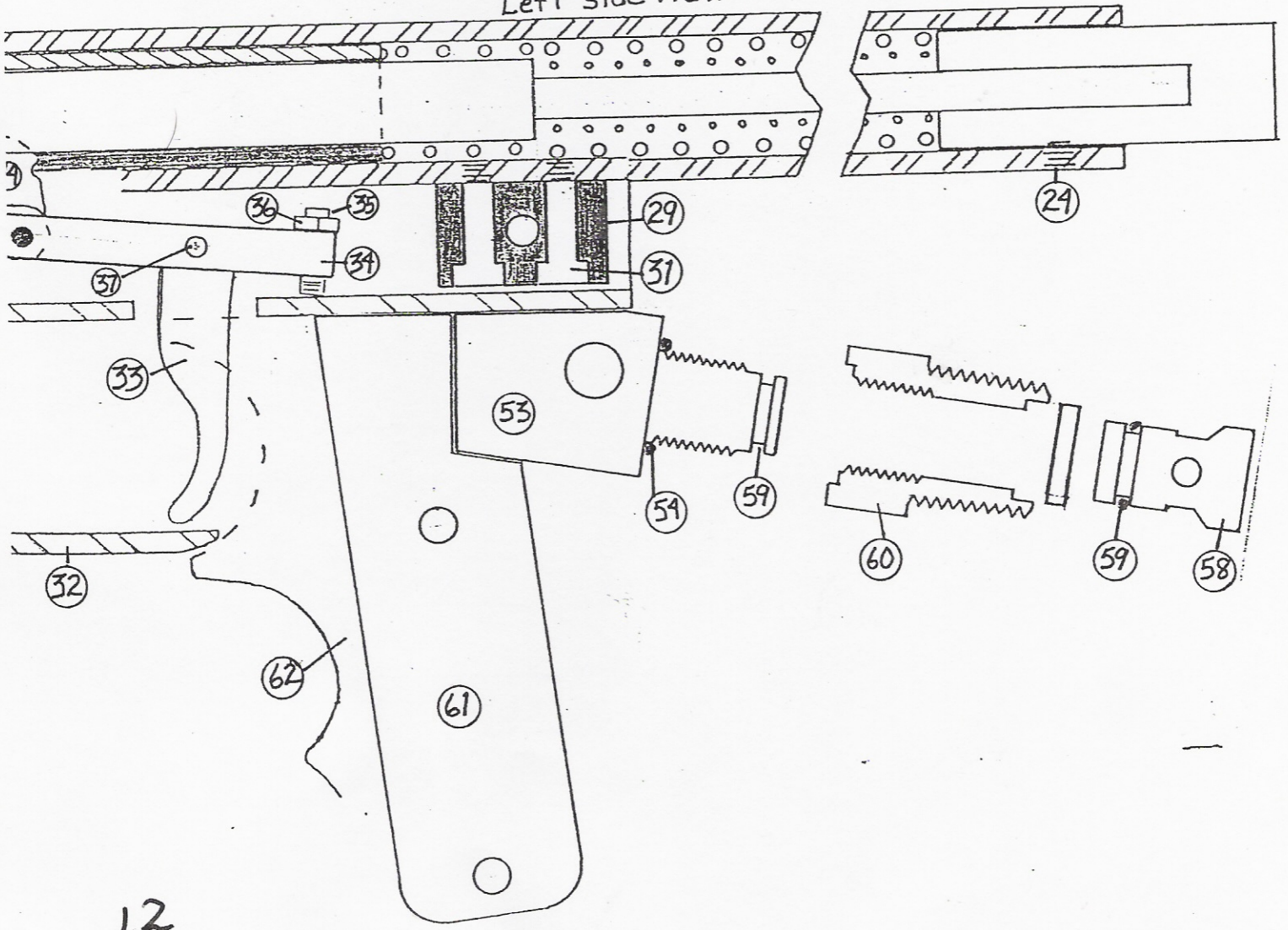

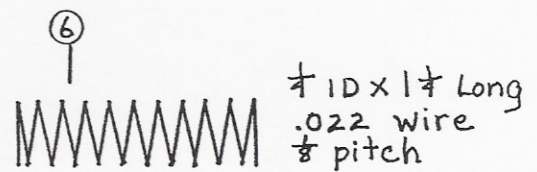
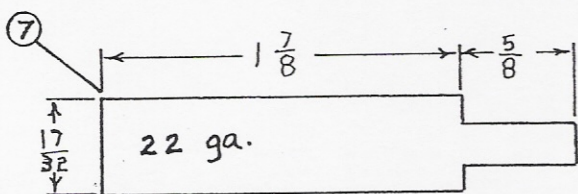
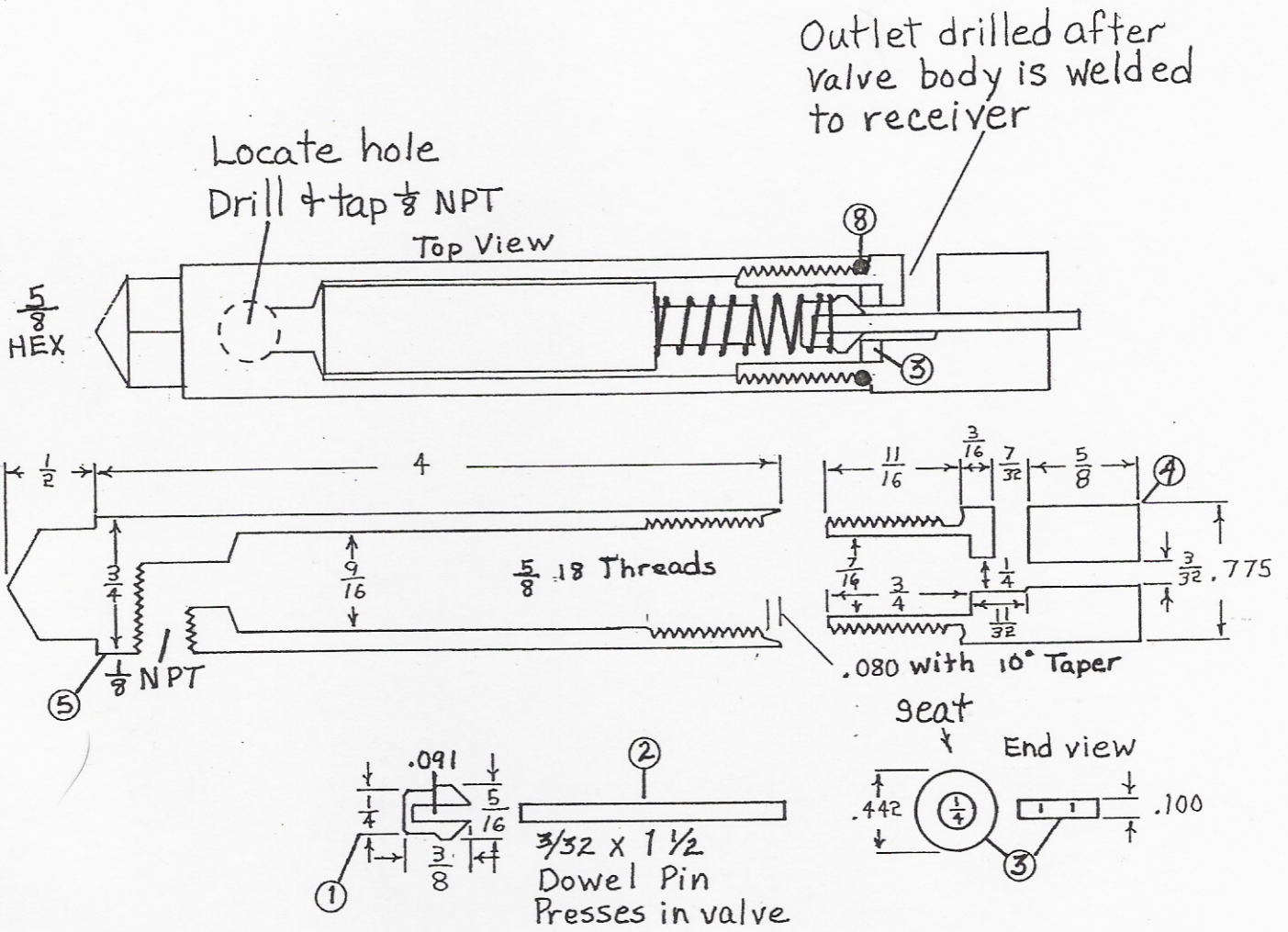

1. Firing Valve
2. Firing Valve Stem
3. Firing Valve seat
4. Firing Valve body
5. Firing Valve holding area
6. Firing Valve spring
7. Firing Valve spring guide
8. Firing valve O ring

End view

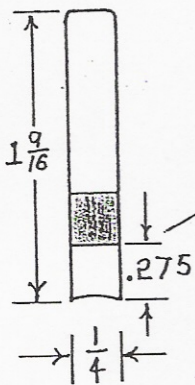

Brazed overlay

9

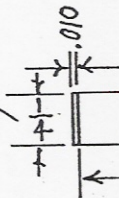

2.360

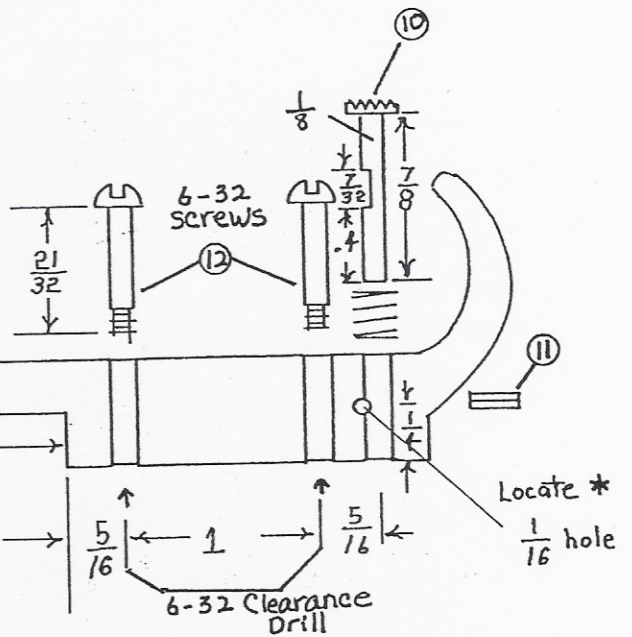

Brazed on

14

End view

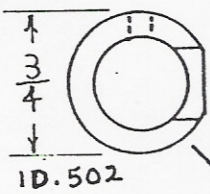

13

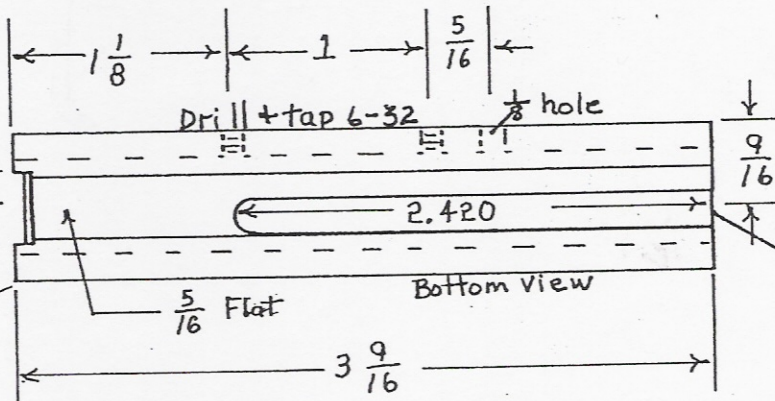

1/16 Slot cut clear through

15

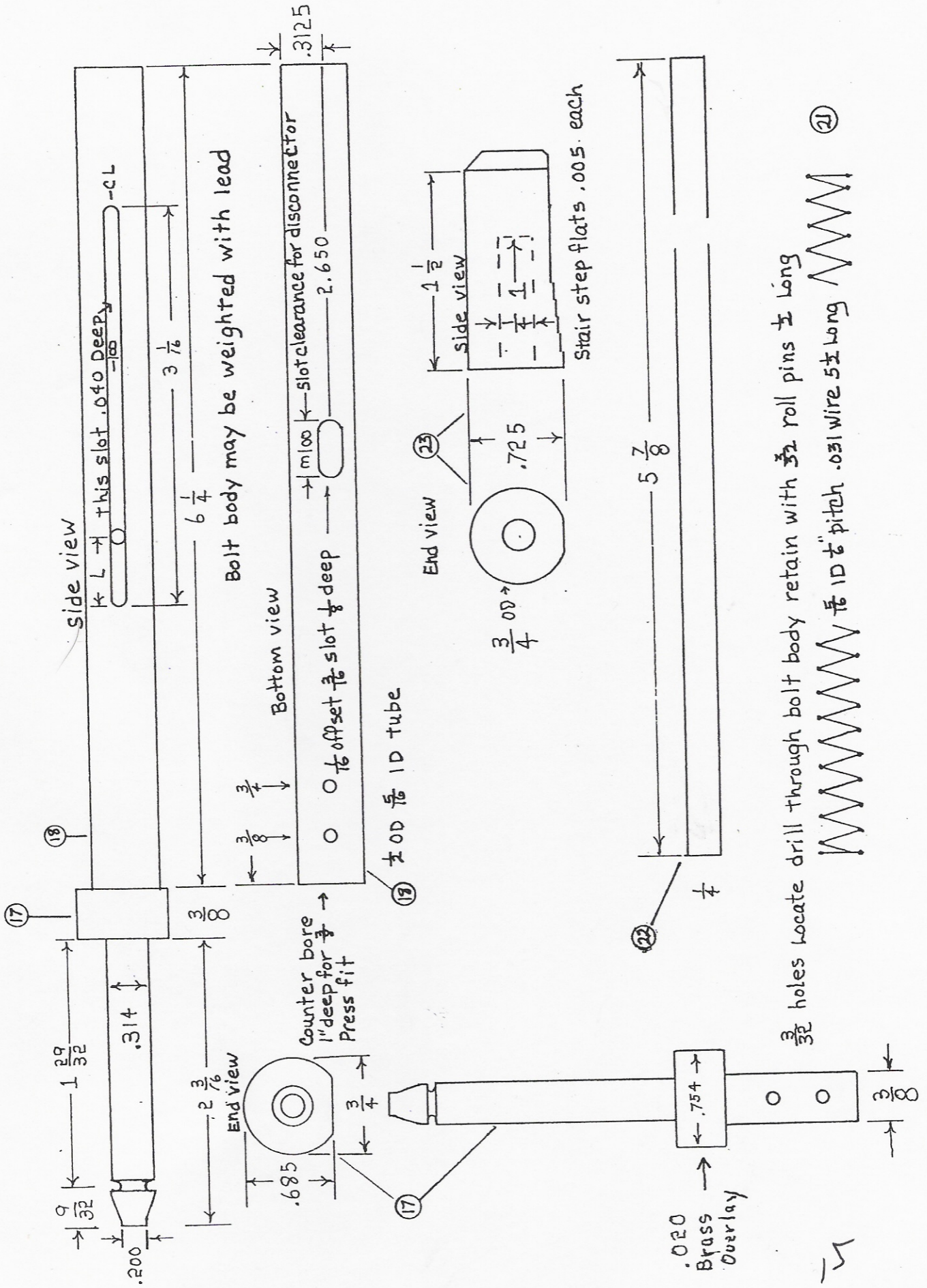

5

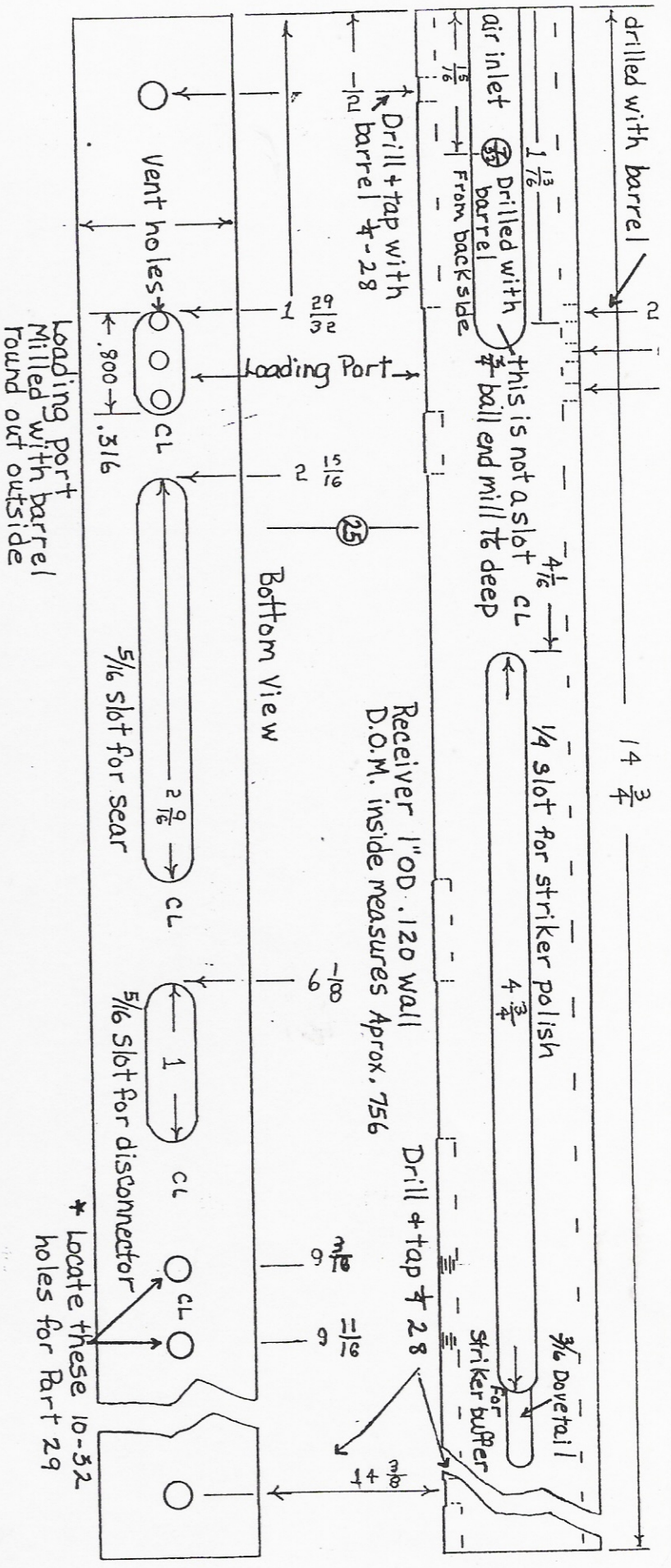

Barrel .311 bottom groove

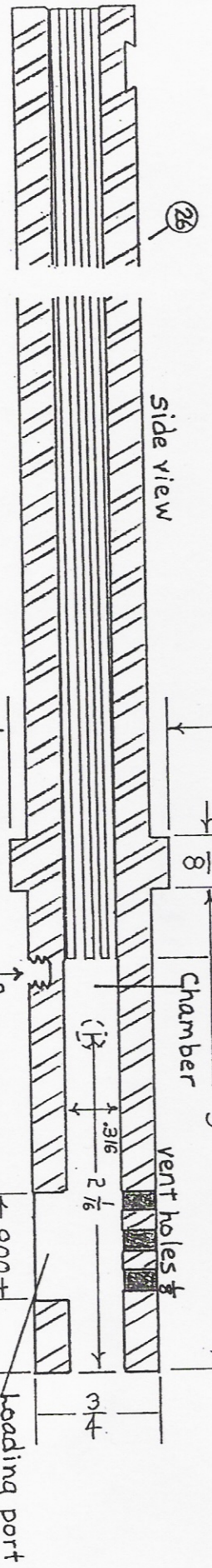

* holes are shown off scale
video shows using standard .316 Reamer to cut chamber + lead

Bottom view

Rear slot cut to weld tank mount through

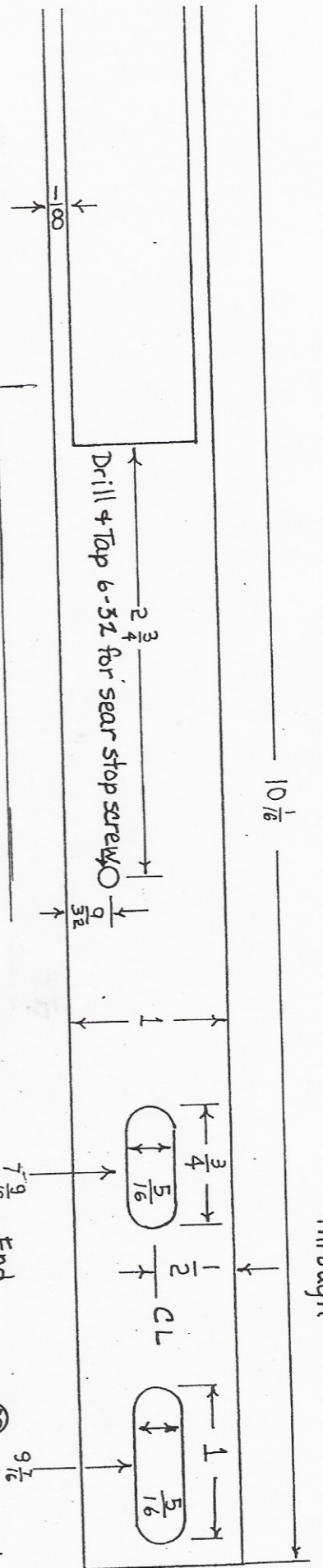

Made out of 1x1/8 square tube top cut off + beveled

Part 29 screws to receiver with 2 10-32 screws to trigger housing & 10-32

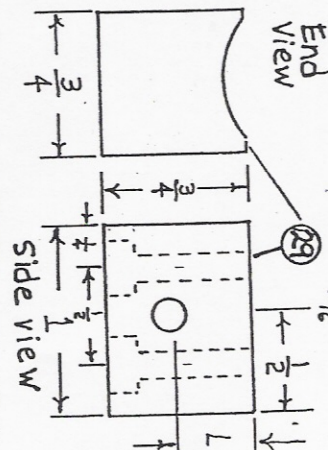
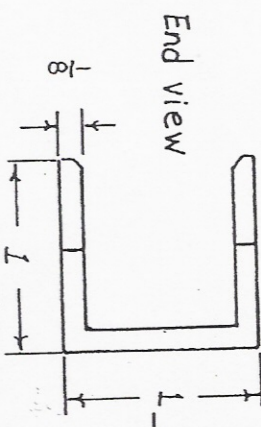

Side view

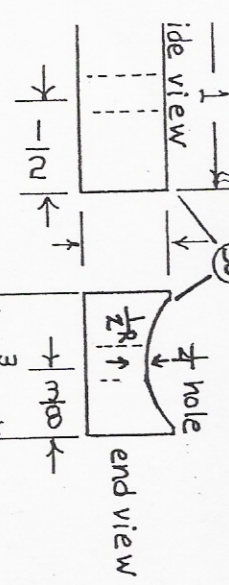
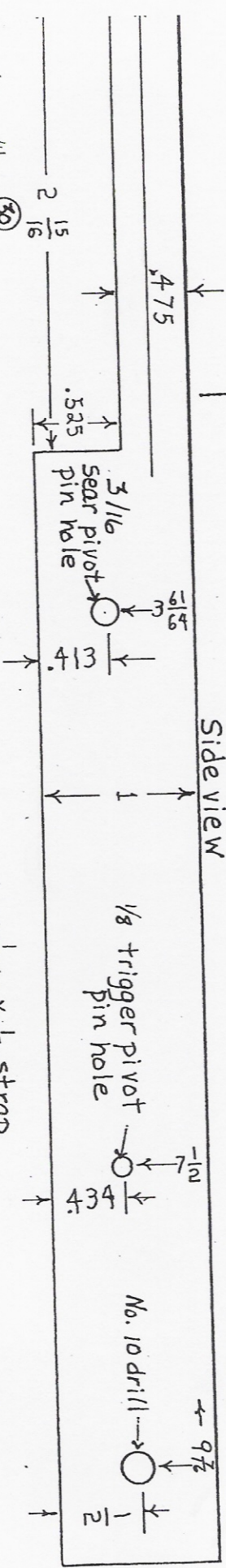

rt 30 screws to receiver + barrel with a 1/4-28 and welds to trigger housing

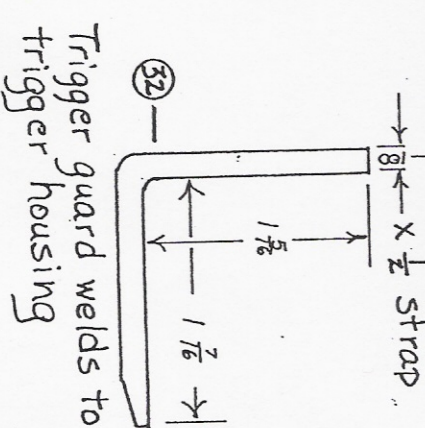

48

End view

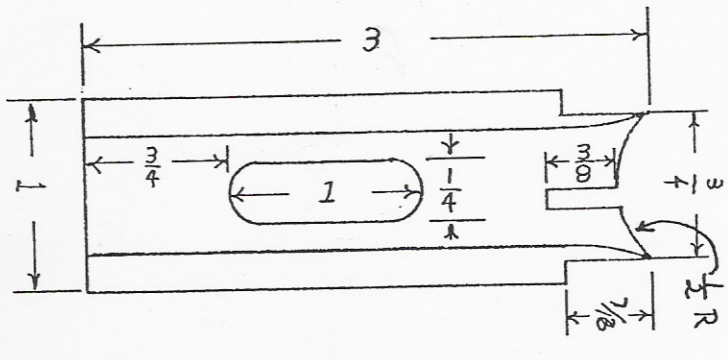

Side view

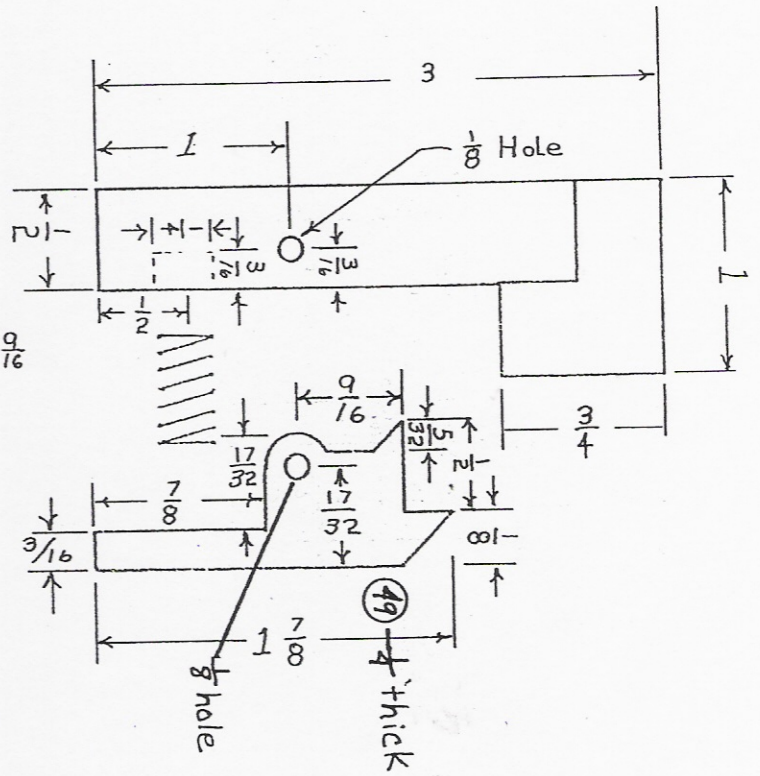

Rear view

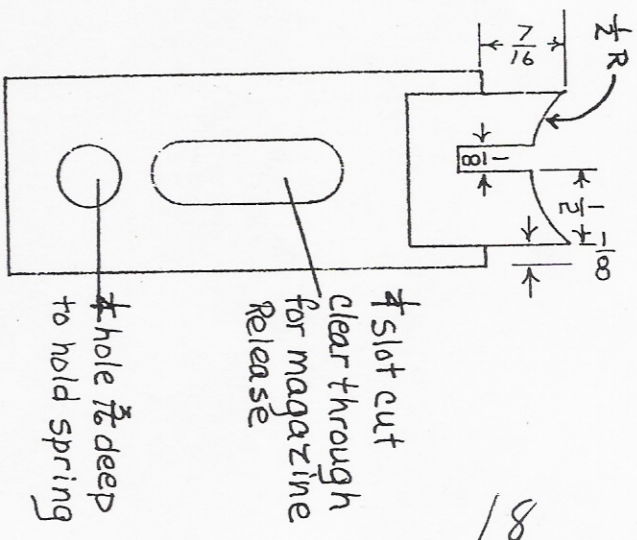

60° 3/4 Dovetail

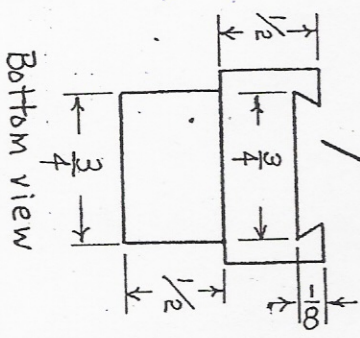

Bottom view

Recessed part of magazine housing slips in trigger housing + welds

Spring 1/4 x 9/16 .030

- 33. Trigger
- 34. Trigger frame block
- 40. Full auto sear trip $\frac{1}{8}$ " 01 tool steel - harden
- 44. Disconnecter $\frac{1}{8}$ " 01 tool steel - harden
- 45. Sear $\frac{1}{8}$ " 01 tool steel - harden

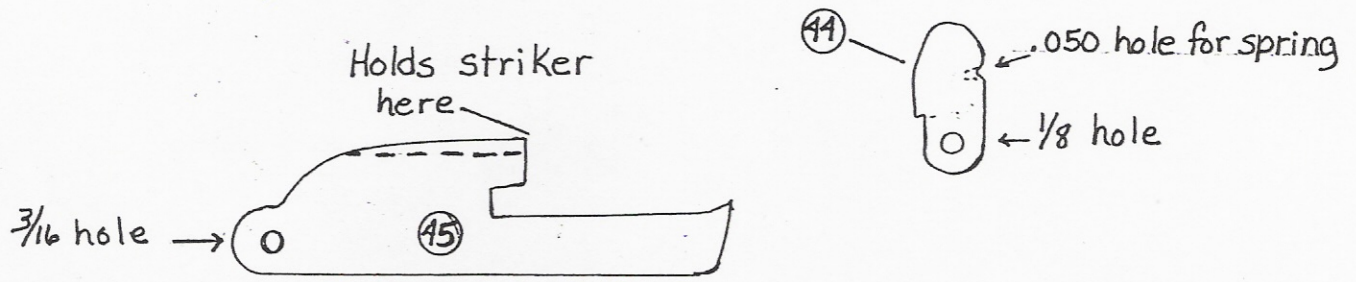

Additional 01 wedge may be added to double sear width

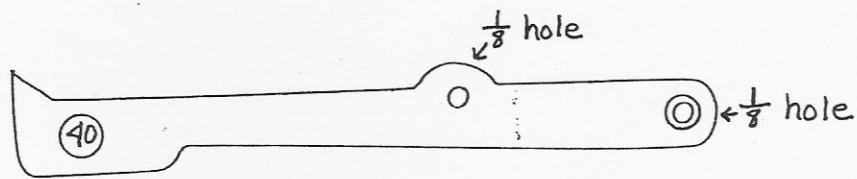

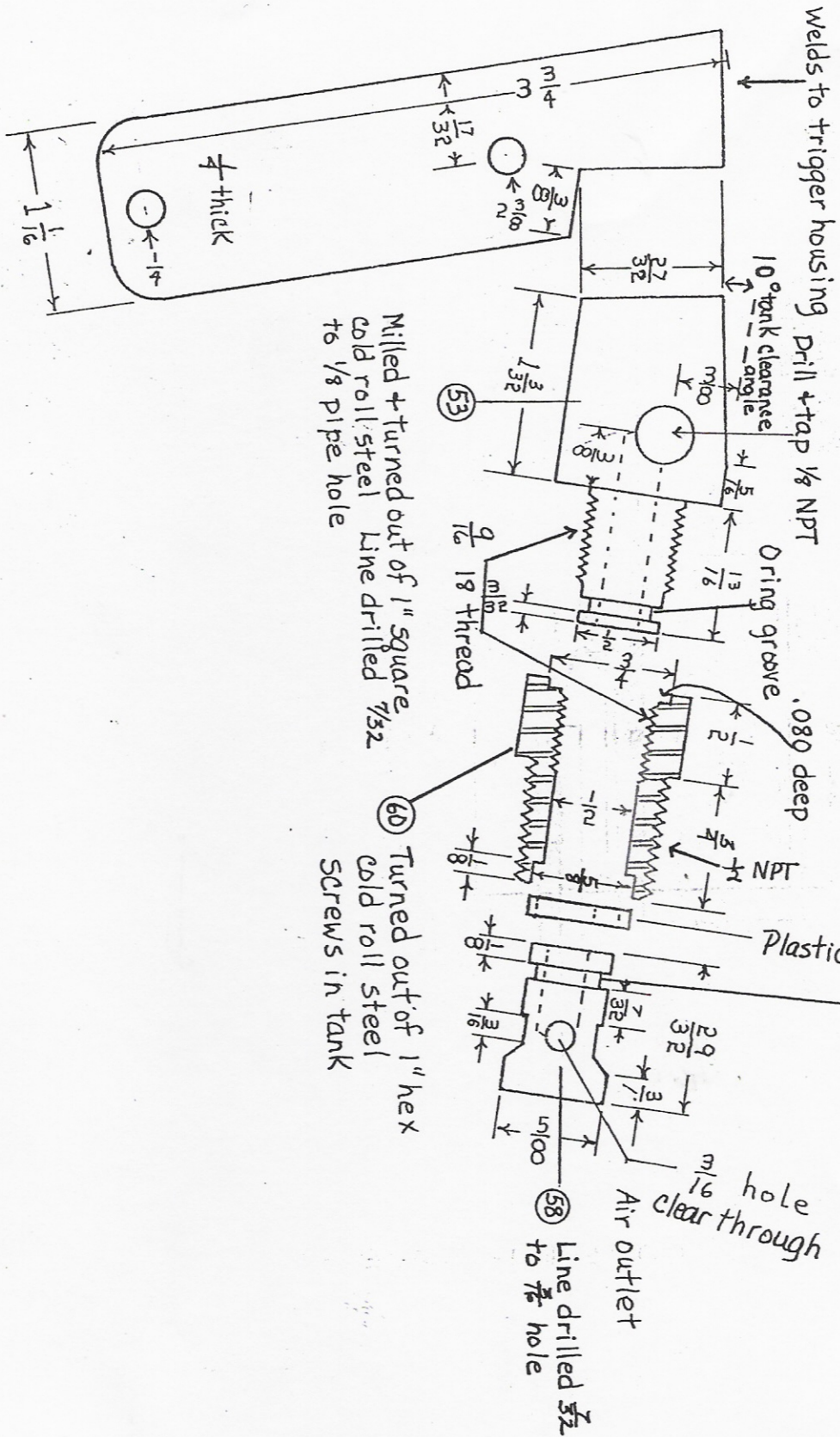

Dring groove made shallow for tight fit this retains valve-air pressure closes it when removed

Milled + turned out of 1" square cold roll steel line drilled 7/32 to 1/8 pipe hole

Turned out of 1" hex cold roll steel screws in tank

* Plastic seat ultra high density .630 dia. with 1/2 hole + 1/4 thick Press in

This has been Revised

$\frac{7}{8}$ OD tube $\frac{3}{4}$ ID slides
over barrel

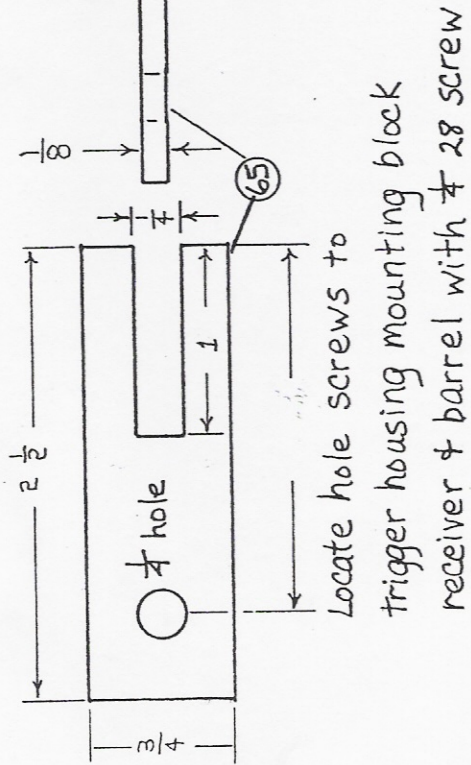
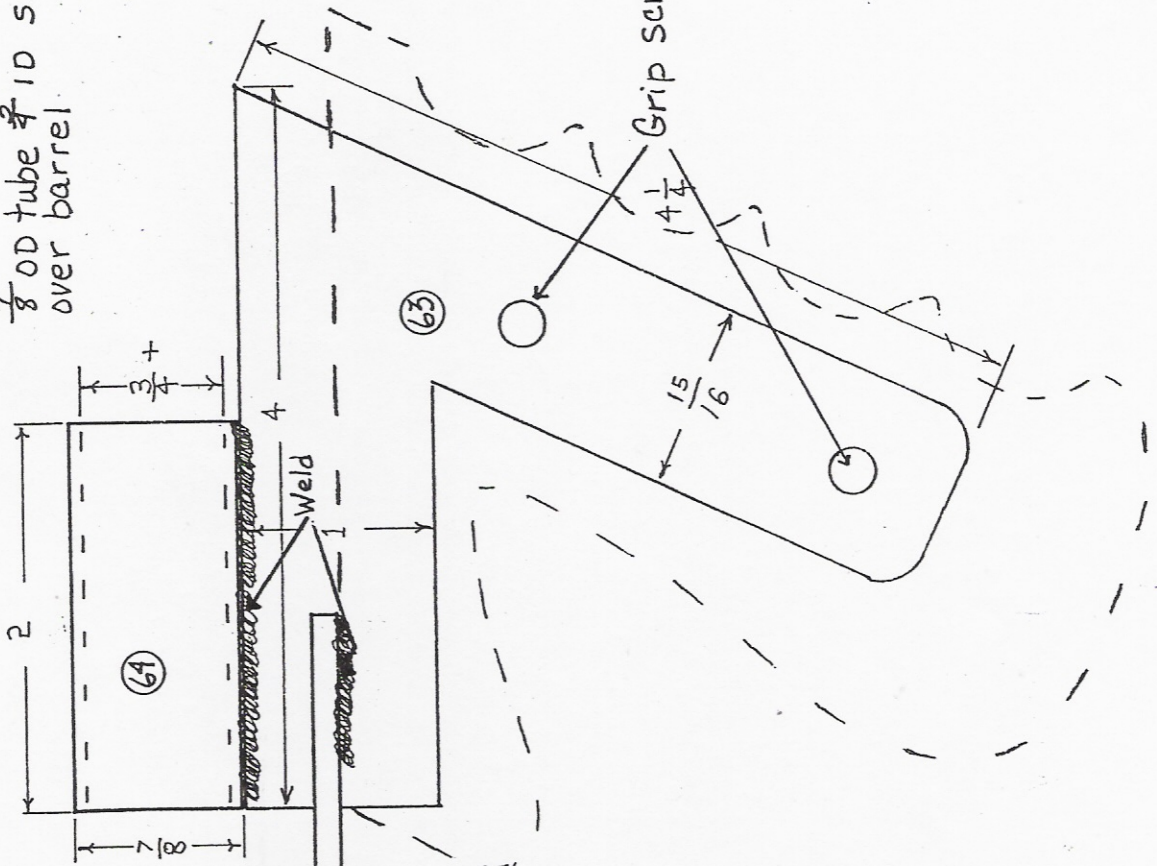

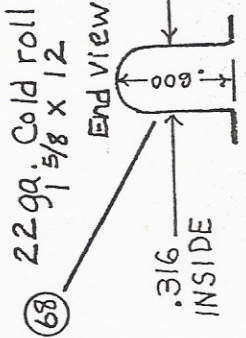

Braze together

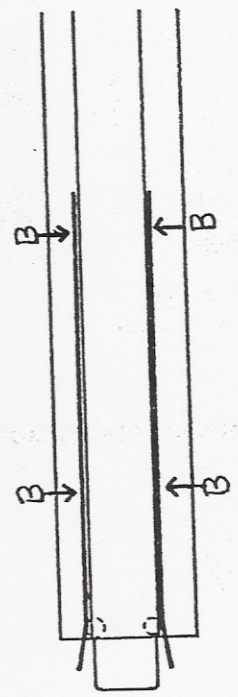
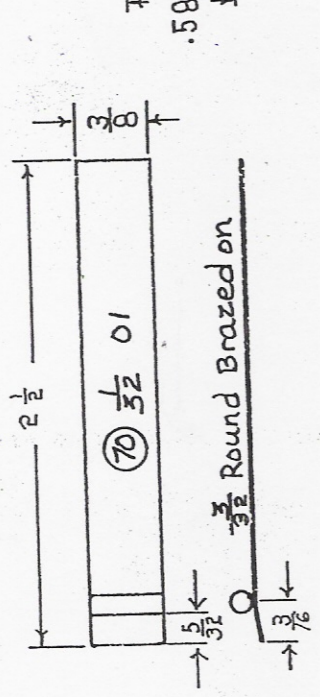
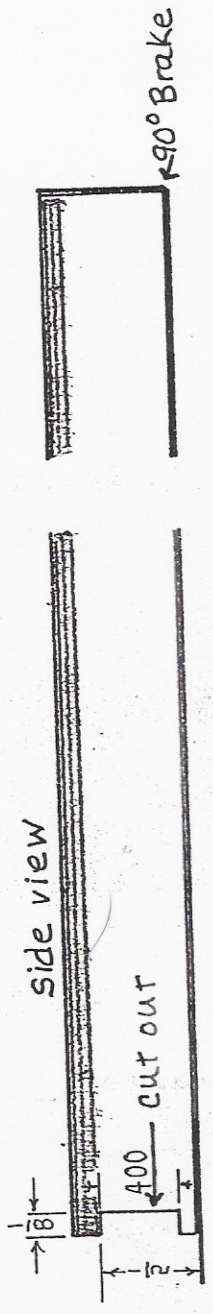
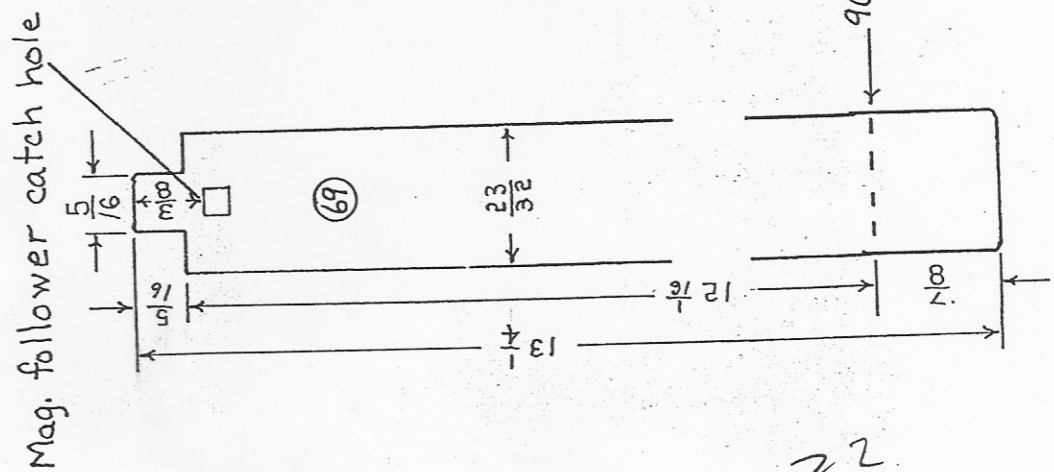

B Braze bullet holders on magazine
1" back from end. Heat to deep
red - dip in oil then draw back
to spring hard

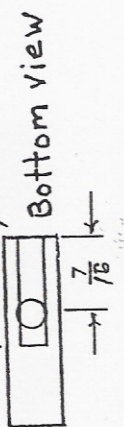
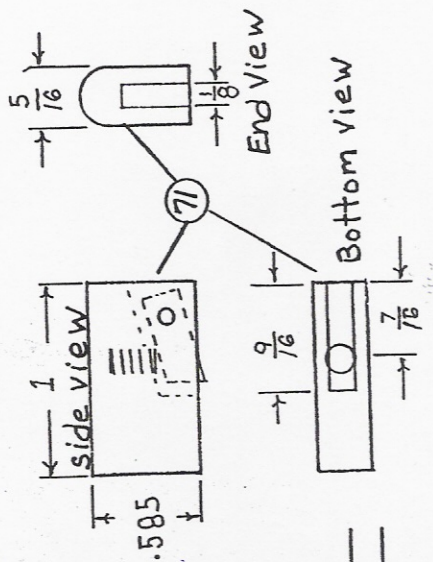

Mag. follower catch prevents follower from coming out and staying in gun

Magazine spring .029 music wire discussed earlier ~ construction shown in video

SIMPLE TRIGGER ASSEMBLY

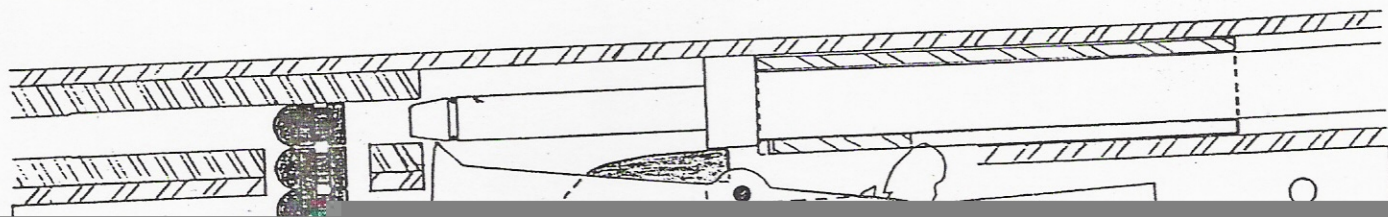

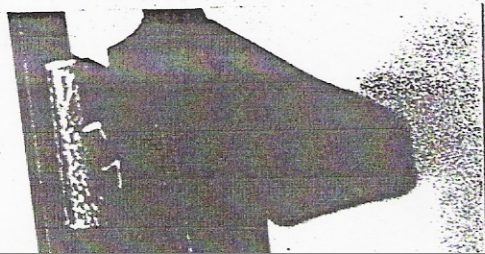

10



6

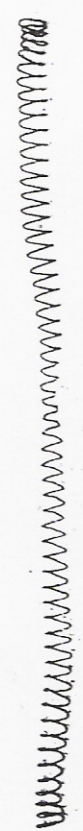

Springs

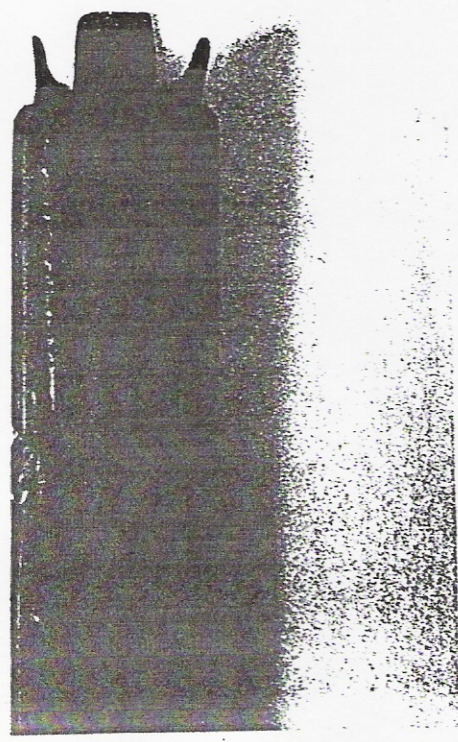

Magazine end

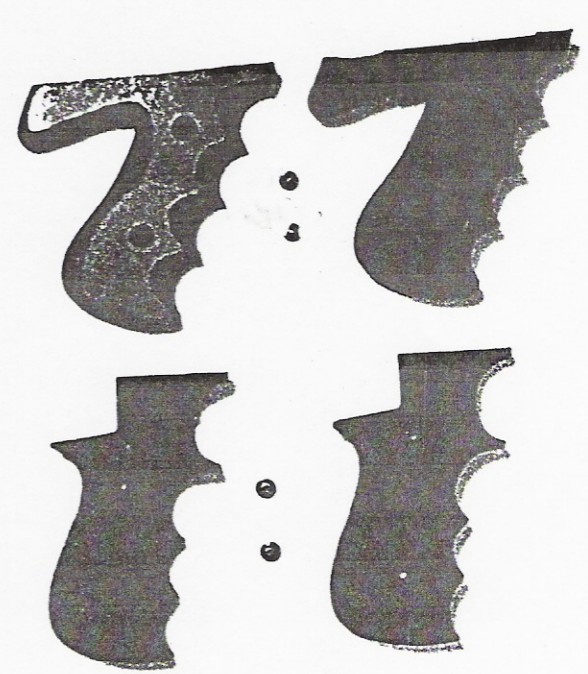

Grine

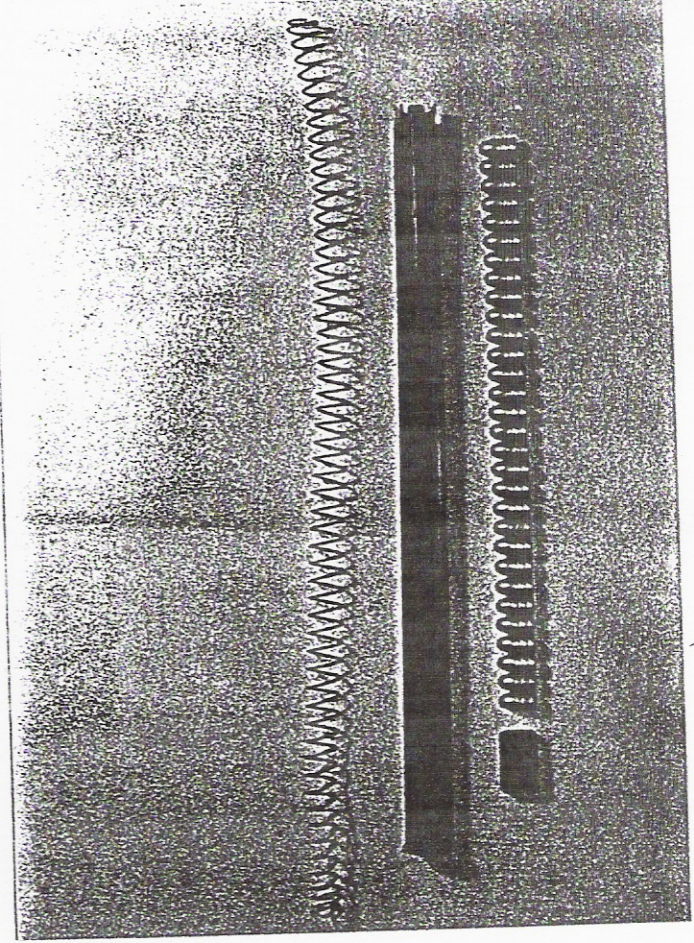

Magazine assembly

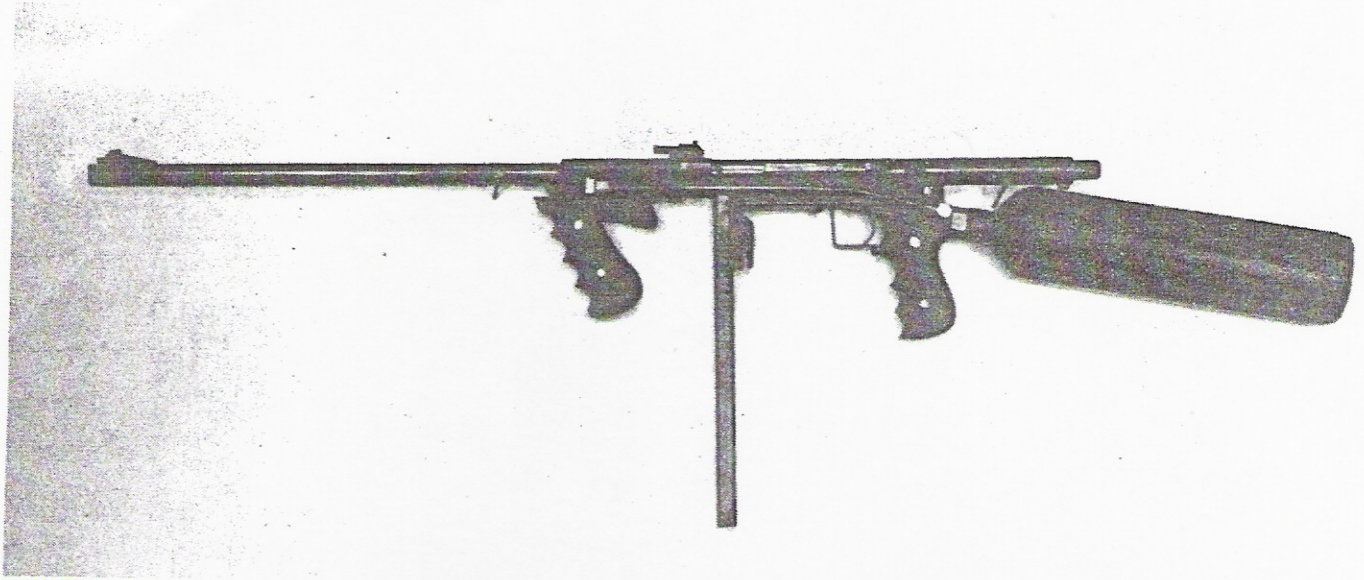

With gun prohibition staring us in the face...it's nice to know you don't have to be without protection. This gun was designed with the idea that any and all guns could be banned, ammo could be illegal or unavailable. That's why we strongly urge you to have the plans. To have the security of knowing you can make a high powered automatic with high pressure air, and mold your own bullets. It is a **self-sufficient alternative for home protection & defense**, and also **inexpensive machine gun shooting and enjoyment**.

This gun is a basic **blow back system** designed to operate from a **pre-pumped detachable tank** of approx. 100 cu. in capacity, which is the shoulder stock. It can be extremely powerful for 30 shots, or tuned down to 150 shots for shooting pleasure. Pressure drops slightly from shot to shot, but our valve design tends to compensate for it. **There are many sources of air:** dive shops, divers tanks, small DC compressors from military surplus, air craft strut pumps and shop built hand and motor driven two and three stage pumps. Liquid CO2 is 1000 lbs. of pressure at 83 degrees, and as long as there is a liquid portion in the tank the pressure would remain the same at 83 degrees. (Although 1000 lbs. of pressure would be low for higher velocity's.) This would give several hundred shots per tank and it could be refilled from a fire extinguisher. The gun has a **30 round detachable magazine**, with a bullet mold selected to cast a 1 in 40 parts tin bullet. It is a **selective fire** with a **two stage trigger**. The first stage is **semi-auto** and the second stage is **full-auto**. This alternative weapon can be built on a lathe with a milling attachment and basic shop tools, and **will saw off a 2x4 at 25 yards!**

Although the engineering has been long in the making, we now have a totally new concept in air gun shooting. The complete detailed plans reveal this awesome new design for \$19.95 with the instruction and performance video only \$59.95.

The 30 caliber air machine gun was individually handmade, although any and all parts may be ordered at an hourly shop rate from:

CASELMAN EXPLORATIONS, BOX 348, CAMERON, MO 64429

A recent reply we received writes: "I found your design very simple and powerful."

PLANS OFFER:

OUR MACHINE SHOP ASSISTANCE ON ANY OR ALL PARTS
RAW MATERIAL KITS
COMPLETE MACHINED KITS
MAGAZINES
BULLETS AND BULLET MOLDS
LIGHTWEIGHT TITANIUM TANKS
CALIBER CHANGE FORMULAS
VELOCITY FORMULAS
CONSTRUCTION AND PERFORMANCE VIDEO
NEWSLETTER OF THINGS TO COME

CASELMAN EXPLORATIONS

BOX 348
CAMERON, MO 64429



WARNING:

This file is distributed for **FREE** and under **COPYLEFT** (www.gnu.org/copyleft/) and **CREATIVE COMMONS** (www.creativecommons.org) Licenses.

DO NOT SELL IT - DO NOT BUY IT - KEEP IT FOR FREE TO ALL AND EVERYONE WHO MAY NEED IT OR JUST WANT TO KNOW IT!

It is for **FREE**, and I worked hard and spent 15 years and several hundred Dollars to give it for **FREE**.

Please, distribute it among your friends, fellow citizens, other survivalists, pro-gun civilians and police and military people, place it for **FREE** to be downloaded on websites all over the **WEB**,

keep it surfing the information highway.

Only one who can SELL this Book & Blueprints is the sole Author and Inventor Mr. JEFF CASELMAN.

This work is being distributed under the spirit of helping people to have easy access to combat weapons by building it, even when under siege by any criminal Government or Tyrant.

THE RIGHT TO HAVE GUNS IS THE RIGHT TO BE FREE - AND NEVER GIVE AWAY YOUR FREEDOM!!!

The CopyRights of this Electronic Edition is by Mad Abe, that is, myself – and I´m givin´ it away for FREE – please, keep it so forever.



Mad Abe

Website: www.bioark.com.br,

E-Mail: brazilian.contractor@gmail.com,

São Paulo, SP, Brazil,

02:33:11 AM local time,

Moonday, August 21St., 2006.