

LA-9475-MS

Los Alamos National Laboratory is operated by the University of California for the United States Department of Energy under contract W-7405-ENG-36.

DO NOT CIRCULATE
PERMANENT RETENTION
REQUIRED BY CONTRACT



*Acoustic Properties of Explosive-Driven
Shock Waves in Noble Gases*

Los Alamos Los Alamos National Laboratory
Los Alamos, New Mexico 87545

This work was supported by the US Air Force Weapons Laboratory.

DISCLAIMER

This report was prepared as an account of work sponsored by an agency of the United States Government. Neither the United States Government nor any agency thereof, nor any of their employees, makes any warranty, express or implied, or assumes any legal liability or responsibility for the accuracy, completeness, or usefulness of any information, apparatus, product, or process disclosed, or represents that its use would not infringe privately owned rights. References herein to any specific commercial product, process, or service by trade name, trademark, manufacturer, or otherwise, does not necessarily constitute or imply its endorsement, recommendation, or favoring by the United States Government or any agency thereof. The views and opinions of authors expressed herein do not necessarily state or reflect those of the United States Government or any agency thereof.

LA-9475-MS

UC-34

Issued: September 1982

Optical Properties of Explosive-Driven Shock Waves in Noble Gases

C. R. Jones
W. C. Davis

7-0402

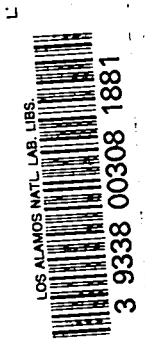

 **Los Alamos** Los Alamos National Laboratory
Los Alamos, New Mexico 87545

OPTICAL PROPERTIES OF EXPLOSIVE-DRIVEN
SHOCK WAVES IN NOBLE GASES

by

C. R. Jones and W. C. Davis

ABSTRACT

High explosives have been used to shock-heat rare gases to brightness temperatures up to 36 000 K. Temperatures were determined from radiometer signals at both 280 nm and 520 nm. Shock velocities up to 9 mm/ μ s were used in both planar and cylindrical geometries. Neon, argon, krypton, and xenon gases at atmospheric pressure were examined in planar shocks. Using argon, the effects of initial gas pressure and an admixed molecular species were observed. For a radial shock expansion in argon, brightness temperatures were measured over a range of shock velocities. Close agreement between brightness temperatures measured at both uv and visible wavelengths indicated that the shock fronts were radiating a blackbody spectrum. Time-resolved spectrograms of the emission also suggest that these sources are blackbody radiators. For a cylindrical shock expansion in argon, explosive energy was converted to optical energy with an efficiency of 4%.

I. INTRODUCTION

Experiments addressing optical properties of explosive shock-driven light sources are reported. The major purpose of these experiments was to identify the parameters affecting the brightness temperature of shock fronts created in rare gases by means of high explosives.

The basic apparatus for these experiments was the argon flash charge, which has been used for many years at the Laboratory and elsewhere as a bright visible light source for explosive-test photography. As a result, these sources have been characterized fairly well in the visible part of the spectrum.¹ In at least one program, however, there is a requirement for bright ultraviolet (uv) light sources. Therefore, we have performed approximately 40 experiments on HE-driven light sources using both uv and visible diagnostics.

The primary goal was to determine the brightness temperature of both planar and cylindrical shocks in argon gas. In addition, the temperature was measured for planar shocks in neon, krypton, and xenon. We also determined the shock velocity and observed the shock front stability in both planar and cylindrical geometries. In the planar geometry, the effect of a molecular impurity in argon was observed, as well as the effect of argon pressure.

In the next section, experiments on the planar shock waves will be discussed. Following that, the cylindrical geometry experiments will be addressed. The fourth section will compare these results with those of other workers. In the final section, the results will be summarized and conclusions presented.

II. EXPERIMENTS ON PLANAR SHOCK WAVES

The first subsection will discuss the phenomenology of planar shock waves propagating down cylindrical tubes. The important characteristics of these light sources, including various wall interactions, are featured. The subsequent subsection will describe the experiments on the ultraviolet emission from these planar sources.

A. The Explosive-Driven Argon Shock Tube

The interacting waves in the argon shock tube or argon flash charge were photographed using a smear camera. This camera has a narrow

entrance slit and accepts and records only that light emitted along a diameter of the shock tube. The image of the entrance slit is swept along the film after reflection from a rotating mirror. The record on the film therefore shows the intensity of the light from the tube as it varies with time. Time increases in the long direction of the film while space along a tube diameter is represented perpendicularly.

Four shock tubes were photographed. Each tube was made of dural, with an inside diameter of 3.5 inches (88.9 mm) and a wall thickness of 0.25 inch (6.35 mm). The lengths of the tubes were 1 inch (25.4 mm), 2 inches (50.8 mm), 4 inches (101.6 mm), and 6 inches (152.4 mm), respectively. The records are shown in Fig. 1. Time marks on the films are 1 μ s for each large division, so the total width is about 19 μ s. In the spatial direction each tube is 88.9 mm in diameter, and the width of the bright bands at the left edge corresponds to this distance.

The shock tubes were driven by a 4-inch diameter plane-wave lens (a P-040 lens made of Composition B and Baratol) that initiated a plane detonation wave in a disk of PBX-9404 explosive that was 4 inches (101.6 mm) in diameter and 1 inch (25.4 mm) thick. PBX-9404 is a high-energy plastic-bonded HMX composition. Its density is 1.84 g/cm³, detonation velocity 8775 m/s, and detonation pressure 35.6 GPa. The disk of PBX-9404 drives the shock wave in the tube; the lens merely provides almost simultaneous initiation of the disk on one face. The explosive disk seals one end of the argon shock tube. The other end is sealed by a glass window about 30 mm thick.¹

At the left edge of the smear camera records, corresponding to the time when the detonation wave in the explosive reached the interface with the argon, we can see the light intensity rise to full brightness in about 0.1 μ s (one small division). This risetime is the time needed to shock enough argon to get one or two optical depths so that it radiates as a blackbody. The shock wave travels about 9 mm/ μ s and the density of the argon at one Los Alamos atmosphere is about 0.0013 g/cm³, so that in 0.1 μ s about 0.00117 g/cm² becomes optically thick. The compression of the argon by the

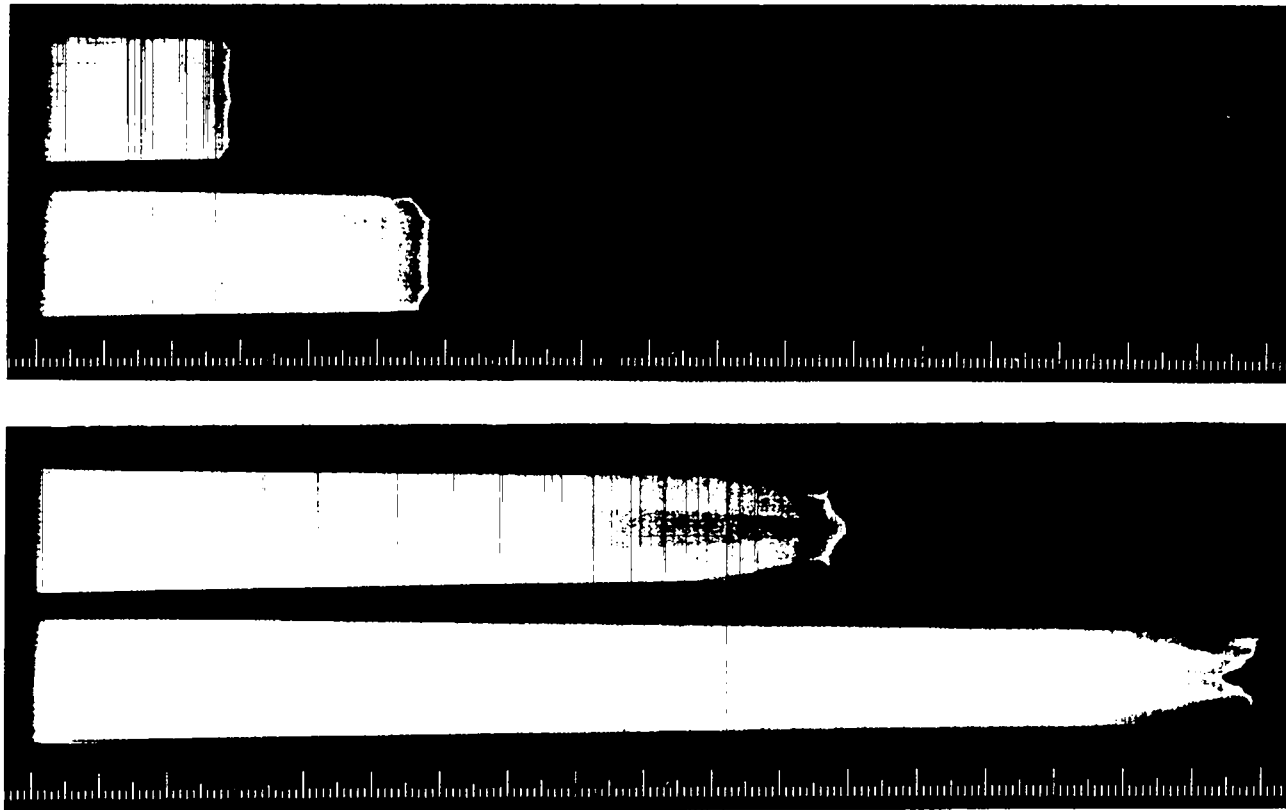

Fig. 1. Smear camera record of the light emitted by the strong shock wave in argon driven by explosive. Time extends in the long direction of the film; each small division of the scale is $0.1 \mu\text{s}$. Space along a diameter of the confining tube is in the perpendicular direction; the diameter is 88.9 mm. The records are from four different tubes with lengths of 1, 2, 4, and 6 inches. Brighter waves coming in from the sides are caused by precursor waves described in the text. They arise because the radiation heats a thin layer of gas along the tube walls, and the main disturbance drives a faster moving precursor in the hot layer.

shock is about 12, so the layer is only 0.075 mm thick. Ahead of it lies unshocked argon at atmospheric pressure, and behind it are the explosive product gases. The striations in the light that persist for about 0.5 μ s are caused by small imperfections in the wave from the explosive, amplified by the instability of the interface of the argon and explosive products. As the argon layer becomes thicker, these little ripples lose their effect.

In a detonating explosive, the pressure is highest at the detonation front, and it falls rapidly in the gases following the front. As time goes on, the pressure in the products driving the argon falls, and the shock wave slows down a little. Since the temperature depends on the shock speed, the shock temperature and shock brightness decrease with time. The decrease can be seen along the center of each shock tube, but only up to about 13 μ s in the longest tube. The x-t (length and time) data from the three tubes in which a plane segment of the main shock reaches the end window are fit fairly well by

$$x = 697[1 - \exp(-0.013t)] ,$$

with x in mm and t in μ s. The shock velocity, obtained by differentiation, is

$$U = 9.06 \exp(-0.013t) .$$

Radiation from the argon shock waves is absorbed by the tube boundaries. The window on the end of the tube is transparent for a very narrow spectral region, and absorbs most of the radiation incident on it. The gas next to the window is heated, and as it expands it drives a shock wave back toward the main shock. The intersection of these two shocks can be seen in the short tube about a quarter of a microsecond before the light goes out, and in the 2-inch tube about one-half microsecond before the end. The light brightens for a very brief instant, and then it becomes dimmer than it would have been. The reflected shock in the argon that has been heated by the main shock heats it even more, and the light brightens. This very hot shock is optically thick very quickly because it is so hot. The argon heated by the transmitted shock is not as

hot. The bright light is transmitted through it until it becomes optically thick, and then the light dims to correspond to its temperature.

The end of each record shows what happens as the shock wave reaches the glass window. As the shock reflects, the pressure increases and the temperature jumps to a high value. The light brightens correspondingly, but then very quickly goes out. The cooling of an opaque layer next to the glass window is probably caused mainly by radiation. Other experiments have shown, however, that the rate of cooling depends on the composition of the surface of the window. Perhaps some relatively cold glass, evaporated by the absorption radiation, mixes with the hot argon to form a cool, opaque layer at the interface.

The phenomena that occur at the wall of the dural tube may, perhaps, be more easily understood by first considering another analogous effect well known to those who work with explosives. It happens in cracks in the explosive, or in the space between explosive and metal when the parts do not fit closely. Let us take the case of a cylinder of explosive in a metal tube with a space (filled with air) between the explosive and the tube. Figure 2 shows the positions of various fronts after the detonation has proceeded up the

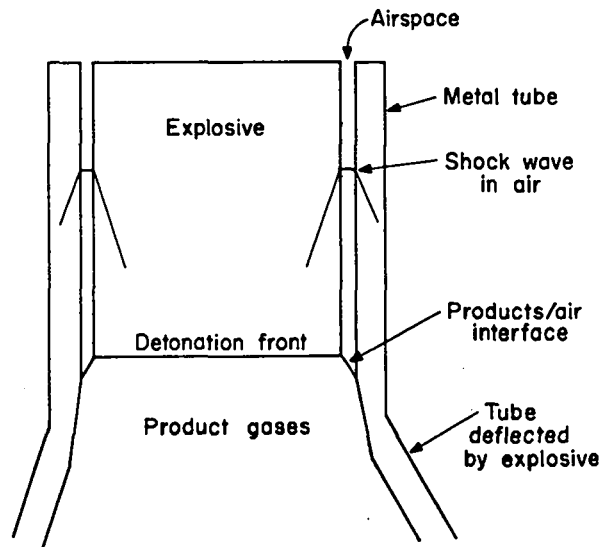

Fig. 2. Diagram of explosive in a metal tube with an air gap between the explosive and the tube. The dense explosive-product gases drive a precursor shock in the air layer.

tube for some distance. The air in the annular gap is compressed by the expanding explosive products, and driven up the gap. All the air that was in the gap is now compressed between the products-air interface and the shock wave in the air. The shock in the air runs ahead of the detonation front, getting farther ahead as time goes on. The shocked air transmits its pressure to the metal tube on one side and the unreacted explosive on the other. The pressure is relatively small, however, about 0.1 GPa, and neither the solid explosive nor the metal deflects appreciably. There are shocks in both, shown as lines from the front of the air shock going back at approximately the Mach angle.

Figure 3 shows the positions of the various fronts in the argon shock tube. The thick heated layer of argon at the wall is less dense than the bulk of the argon, and it takes the place of the air gap in the explosive tube. The shock in the bulk argon acts as the expanding explosive products did in Fig. 2, driving the hot gas ahead of

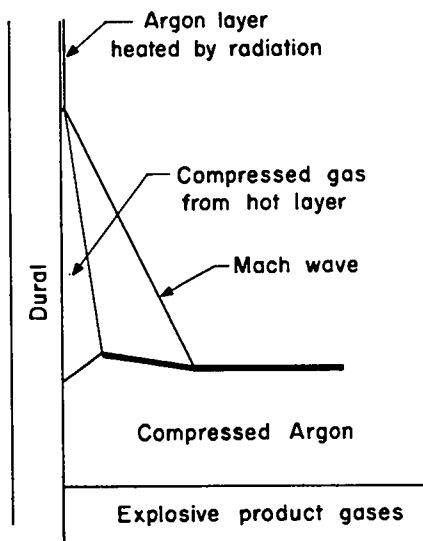

Fig. 3. Diagram of an argon shock wave in a metal tube. There is a layer of hot argon at the tube wall ahead of the main disturbance, because the intense radiation from the hot argon at about 24 kK is absorbed at the wall and heats the gas near it. A precursor is driven by the main shock wave, and it runs ahead in the hot layer. The precursor in the hot layer causes a shock wave (Mach wave) in the bulk of the argon, and this wave is responsible for some of the main features seen in the smear camera records.

it. There is a big difference in the compressibility of the argon relative to that of the explosive, and the Mach wave from the precursor shock heats the argon appreciably. The main shock then heats the gas further, so it appears brighter.

The smear camera trace, Fig. 1, shows the brighter light from the gas that is precompressed by the Mach wave and then is shocked by the main shock, which starts at the outside of the tube and then moves in. The compressed gas from the hot layer is not luminous enough to show in the picture, but its presence is shown by the way it obscures the light, thereby making the light region narrower as it runs. (Note that the dark lines, which are defects in the camera slit and which run in the time direction, get closer to the edge as time goes on.) The precursor shock makes a little light when it hits the window; it can be seen at about 4.6 μ s for the 2-inch tube, about 9 μ s for the 4-inch tube, and about 14.2 μ s for the 6-inch tube. Its interaction with the window causes peculiarities in the outside ring as the main shock advances near the window. The intersection of the Mach waves (at about 13.1 μ s in the 6-inch tube), causes a strong brightening at the center. All the oscilloscope traces of shock brightness show this effect. The center of the wave moves very rapidly after the interaction, and while the center was last to reach the window in the 4-inch tube, it is first in the 6-inch tube. After the interaction the shock wave has a convex section at its center, surrounded by a funnel-shaped shock. The cusp at the intersection of these waves shows up as a pair of dark lines in the photographs.

Probably the details of wall interactions, etc., are of little importance for most purposes. It is helpful to understand the details to be sure that some important process has not been missed. It might be possible to enhance the performance of shock-tube light sources by putting in extra interactions to increase the light output.

The precursor waves and other interesting phenomena were studied long ago by R. G. Shreffler and R. H. Christian.² Some of the ideas about the origin of these phenomena discussed here are apparently new. Hydrodynamic modeling of the details will test the correctness of the new ideas.

B. Ultraviolet and Visible Emission from Planar Shock Waves in Rare Gases

Radiometric measurements of the uv and visible radiation emitted by rare gas flash charges are discussed below. The experimental technique will be presented first, followed by results obtained from various tests. Tests were numbered UV-1 through UV-38 in chronological order.

1. Experimental Arrangement. For these tests the source was an argon flash charge described previously and similar to that shown schematically in Fig. 4. This shot was usually located a distance of approximately 6.5 m from the bunker window. This device consists of an argon-filled tube with an explosive charge at one end and a window at the other. The tube, of either cardboard or dural, was usually 30 cm in length and 8.75 cm in diameter. A small gas port was located near each end to facilitate purging the system with argon. In some experiments with a dural tube, an evacuation and fill procedure was used. One end of the tube was sealed with the explosive, a 2.5- × 10- × 10-cm block of PBX 9404. In most tests a P40 explosive plane-wave lens was positioned between the detonator and primary explosive. The other end of the tube was sealed with a thin aluminum plate in which was centered a 1-cm-diam aperture. A quartz window could be placed over this aperture, as shown, or could be omitted.

The light source was directed toward the bunker window via an aluminized front-surface turning mirror shown in Fig. 4. In this arrangement no fragments from the explosion reached the bunker window.

The one or two detectors used for these tests were located just inside the bunker window and were pointed directly toward the source. The centers of the bunker window and detector all lay along a common optical axis that was collinear with the source axis.

Each of the detectors was an ITT F-4018 biplanar photodiode having an S-5 response, giving the detector good sensitivity between 200 and 500 nm. These detectors have a linear dynamic range of nine orders of magnitude. Although not required for this experiment, the response times of the detectors were less than a nanosecond. The recommended bias voltage of 1.0 kV was applied to the detector for these tests.

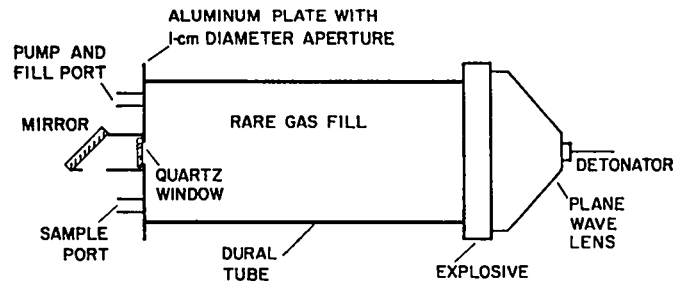

Fig. 4. Schematic of explosive flashlamp or argon flashcharge: typically the tube is 10 cm in diameter by 30 cm in length. Variations include cardboard material for the tube, no window over aperture, no plane-wave lens on primary explosive, different rare gas fill, and use of a turning mirror to direct output toward detectors located inside bunker window.

A band-pass filter centered at 280 nm was mounted onto the front of one detector. The passband of the filter was 20 nm FWHM and the peak transmittance was 17%. The 2.5-cm-diam filter was larger than the 2.1-cm effective diameter of the detector. Light leakage around the filter was reduced by securing the filter in the detector housing by means of a snug fitting O-ring. The detector for the visible measurements was similarly equipped with a band-pass filter having a peak transmittance of 60% at 520 nm and a 9-nm FWHM.

2. Experiment preparation. For each test, the argon flash charge was positioned approximately 6.5 m from the bunker window. It was aligned by carefully boresighting the tube toward the bunker window. The radiometers were positioned inside the bunker to be pointing directly toward the aperture in the source. The optical distance between the source aperture and the detector was carefully measured with a tape measure and recorded.

The signal cable from each detector was terminated with 50 ohms at the input to one of the oscilloscopes. The bias voltage on each detector was set at precisely 1.0 kV. These were the conditions under which the detectors had been calibrated absolutely against standard lamps.³

After the argon purge through the argon flash charge had been flowing for several minutes at 0.5 CFM (for flash charges using a purge fill), the shot was fired. For tests using other rare

gases or a gas mixture, the dural tube was evacuated after sealing with a trapped mechanical pump, then filled to the reported pressure(s).

3. Results from Tests UV-1-6. The first group of tests conducted in this series were Tests UV-1-6. The sources used argon in cardboard tubes described previously. Although these tests have been reported,³ much of that description will be repeated here since it also applies to many subsequent tests.

The uv light pulses resulting from Tests UV-2, 3, and 4 are shown in Fig. 5. UV-2 was a repeat of the conditions of UV-1. In UV-2 there was no window over the source aperture and the detonation was initiated at a point at the rear center of the charge. In UV-3 a uv-grade quartz window over the aperture was added. In UV-4 there was the window in addition to a plane-wave initiation of the detonation. Tests UV-5 and 6 were included only for verification of the first tests.

4. Analysis of pulse shapes. We will first discuss the qualitative features of the pulses. In the top trace of Fig. 5, the large off-scale feature at the end of the pulse is due to the shock-heated argon exiting the open aperture. The brightness increase over that of the first part of the pulse is due to the increase in radiating area as the plasma

is released through the aperture. The time for this event to begin agrees approximately with the known time for the shock to travel down the tube. In the lower two traces of Fig. 5, this large pulse did not appear because the window prevented the plasma from escaping.

In the top and center traces the detonation originated from a point at the rear center of the charge. The shock wave traveling through the argon is therefore diverging. The bump near the center of the pulse is due to convergence of the reflected wave arising when the hemispherical shock wave collides with the cardboard walls. The timing of this bump agrees with the photographic observation of the Mach stem on the axis of the tube at a time of 32 μ s after the trigger.

In the lower trace in which plane-wave initiation was used, there is a much smaller center bump. It is caused by convergence of the "wall waves" discussed above in Sec. IIA. This pulse has an almost constant brightness over the first 28 μ s, after which time it linearly decays, then abruptly terminates. In these sources, the light emission begins when the detonation wave exits the explosive material and enters the gas. The abrupt termination of the pulse occurs when the shock wave reaches the window. The small increase in intensity at the very end of the pulse is due to the higher temperature the gas reaches within the reflected shock.

In each test the distance between the inside face of the explosive and the aperture plate was 30.5 cm. In the center trace the pulse length is 46 μ s and in the lower trace 41 μ s. These values correspond to average shock velocities in the two cases of 6.6 and 7.4 mm/ μ s, respectively.

Using the signals shown in Fig. 5, the brightness temperature and a number of other radiometric quantities may be determined. This is possible because the detector and its filter were calibrated absolutely using a standard deuterium source. The process of determining the temperature of the source, as well as the calibration procedure, is described in Ref. 3.

The "peak temperature" or "temperature" of the source refers to the peak at the leading edge of the pulse. For UV-2, 3, and 4 shown in Fig. 5, the temperatures are 27 kK, 27 kK, and 31 kK,

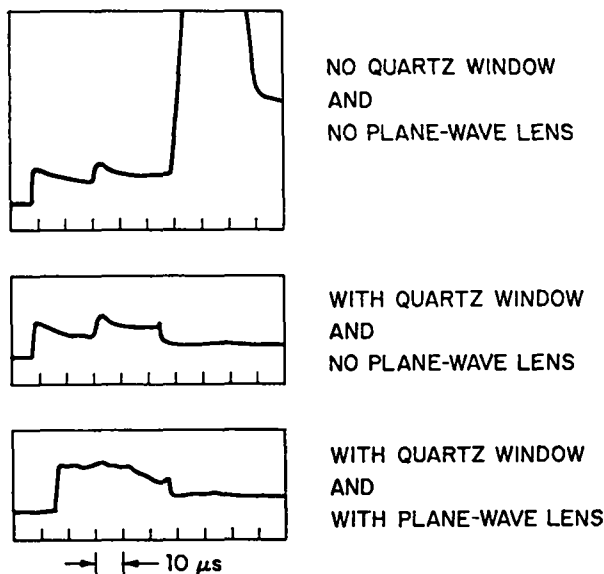

Fig. 5. Signals from 280-nm radiometer for Tests UV-2, 3, and 4.

respectively. The higher temperature for UV-4 is not understood and should not be ascribable to the use of plane-wave lens initiation of the primary explosive (although other features of the signals can be). The UV-2 and 3 temperatures are in good agreement with those obtained from subsequent similar tests. The decrease in emission after the initial peak is typical, reflecting the deceleration of the wave with time as discussed above.

In Tests UV-17, 18 the effects of different tube materials were compared, and the emission was recorded by a $\lambda = 280$ -nm and a $\lambda = 520$ -nm radiometer. One tube was cardboard and the other dural, each having dimensions used before. A plane-wave lens was used in each case. The resulting signals are shown in Fig. 6. At each wavelength the amplitudes for the two tests are nearly equal, indicating peak temperatures of 22 kK at $\lambda = 280$ nm and 23 kK at $\lambda = 520$ nm. The agreement between the temperatures for the two wavelengths suggests that in this spectral region the source is emitting as a blackbody. Note that in the case of the dural tube the pulse length is somewhat shorter, indicating a higher average shock velocity than in the cardboard tube.

In UV-20, 21 the effect of fill pressure on the performance of the argon flash charge is studied. Using dural tubes, the argon pressures are 66 psia and 11 psia (local atmospheric pressure). The resulting signals are the top two in Fig. 7. (The higher pulse amplitude for $\lambda = 280$

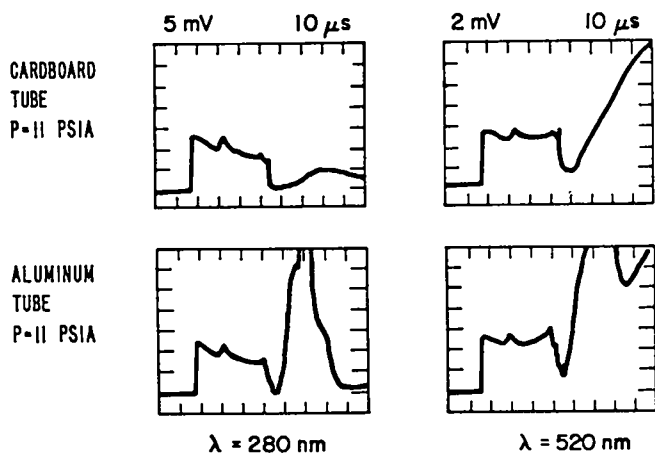

Fig. 6. Signals from 280-nm (left) and 520-nm (right) radiometers for Tests UV-17,18.

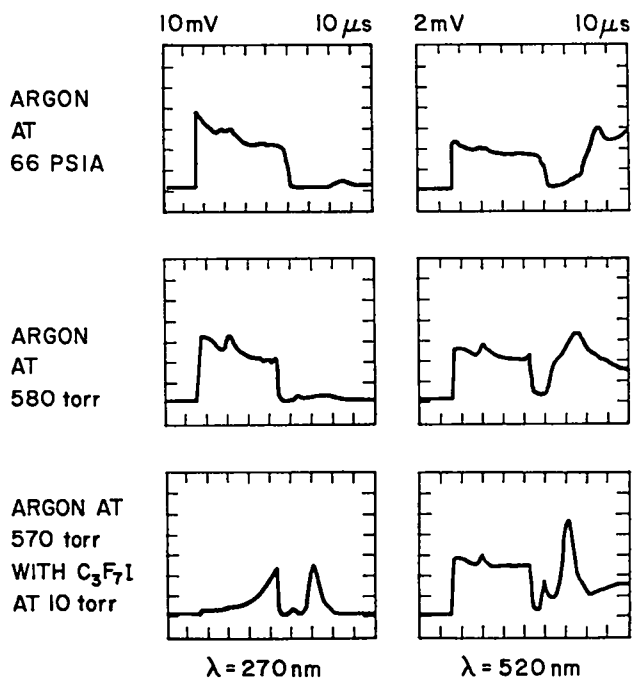

Fig. 7. Signals from both uv and visible radiometers for Tests UV-20, 21, and 22. Effects of argon pressure change are examined in upper two sets. Lower two address effect of molecular species (having a large specific heat) added to argon.

compared to that in Fig. 6 is due to replacing the front-surface aluminized turning mirror having an SiO overcoat with one without the overcoat for greater reflectivity in the ultraviolet.) The peak temperatures for the higher pressure case are $T = 26$ kK at $\lambda = 280$ nm and $T = 23$ kK at $\lambda = 520$ nm. For the atmospheric pressure test, $T = 24$ kK at $\lambda = 280$ nm and $T = 22$ kK at $\lambda = 520$ nm. The greater pulse droop at the higher pressure is due to the expected larger deceleration of the shock wave through the medium of greater density. The longer pulse length also suggests a greater deceleration.

UV-21, 22 compare flash-charge emission with and without an admixed molecular species, C_3F_7I . These signals are the lower two in Fig. 7. A broad absorption band in C_3F_7I centered at $\lambda = 270$ nm absorbs most of the emission detected by the uv radiometer at early times. However, as the emitting shock wave nears the end of the tube the optical density becomes small enough to allow penetration of the pulse tail. The $\lambda = 520$ nm emission, not absorbed by the additive, indicates a

peak temperature of 22 kK. No cooling of the shock wave by ~2% molecular species occurs. In UV-25, 27 this comparison is repeated with 50-torr C_3F_7I . The reduction in temperature was from $T = 23$ kK to 22 kK for $\lambda = 520$ nm. We must conclude that ~10% C_3F_7I does not reduce the shock front temperature. However, the resulting heavier mixture was manifested in a longer pulse and a greater pulse droop, as discussed before.

The results with argon flash charges are summarized in Table I. Averaging these data with two later argon shots discussed below indicates that the peak temperature of these sources is 25 ± 1 kK at $\lambda = 280$ nm and 23 ± 1 kK at $\lambda = 520$ nm. These temperatures correspond to the initial shock velocity of 9 mm/ μ s. After this series was concluded, the radiometers were calibrated once again against the same standard lamps. There were no changes in the calibration factors.

A modest effort was devoted to obtaining time-resolved spectra of argon flash charges. A rotating-mirror ultraviolet spectrograph,⁴ Los Alamos National Laboratory Model 40, was used. One of the resulting records is shown in Fig. 8. The spectral coverage is 250-500 nm. The top edge, near the Hg lamp spectrum, corresponds to the time the shock wave from the explosive entered the argon, and the lower edge is about 30 μ s later. The absence of exposure at the ultraviolet end of the spectrum is probably the result of the lack of film sensitivity in that region. The apparent lowered exposure near the green end is probably caused by the reduced efficiency of the diffraction grating, which is blazed for the near ultraviolet. The three broad absorption features

are thought to be high vibrational level Shumann-Runge bands of O_2 , showing absorption in the air between the flash charge and the spectrograph. There may be some absorption by ozone below 290 nm. There are several sharp absorption lines between 420 and 450 nm that have not been even tentatively identified. These results, although the experiments done so far have shown only that it is possible to obtain spectra, show that corrections for absorption of some of the radiation by air between the shock source and the detector may be needed, and that the molecules responsible for the absorption can probably be identified.

5. Results from Tests Using Other Noble

Gases. Using flash charge set-ups similar to those described above, we have used the uv and visible radiometers to measure the temperature of shockwave fronts in neon, krypton, and xenon. For comparison purposes, argon was included in this series. Gases used in these tests were analyzed for impurities.⁵ For this purpose, a gas sample was taken directly from the gas cylinder and also drawn from the dural flash-charge cell after it was filled. Only the $\lambda = 280$ nm radiometer was used for this series.

The light pulses obtained are shown in Fig. 9. Two different tests were performed for each noble gas, which was drawn from separate cylinders where possible. Helium was not included, because previous tests in other programs have shown that it yields very little light emission. Data from these tests are summarized in Table II.

In comparing the performances of flash charges with fills of different noble gases, the variation of peak temperature is most apparent. Shocks through the heavier noble gases resulted in higher peak temperatures. The average shock wave velocity through the tube is lower for the heavier gases, but the specific heat is much smaller, and the peak temperature is approximately proportional to the square root of the atomic mass. The time required for the light to reach full intensity near the first of the pulse is longer for lighter gases, a feature particularly noticeable for the case of neon in Fig. 9. The lower temperatures in the lighter gases, and the energy of the first excited state, combine to make the opacity of shocked gas depend strongly on the atomic weight.

TABLE I
ARGON FLASH CHARGE SUMMARY

Test Number	Argon Pressure psia	Added Gas	Measured Temperature	
			$\lambda = 280$ nm	$\lambda = 520$ nm
2	11	none	27 kK	--
3	11	none	27	--
4	11	none	31	--
7	11	none	25	--
8	11	none	26	--
17	11	none	22	23 kK
18	11	none	22	23
20	66	none	26	23
21	11	none	24	22
22	11	10 torr C_3F_7I	--	22

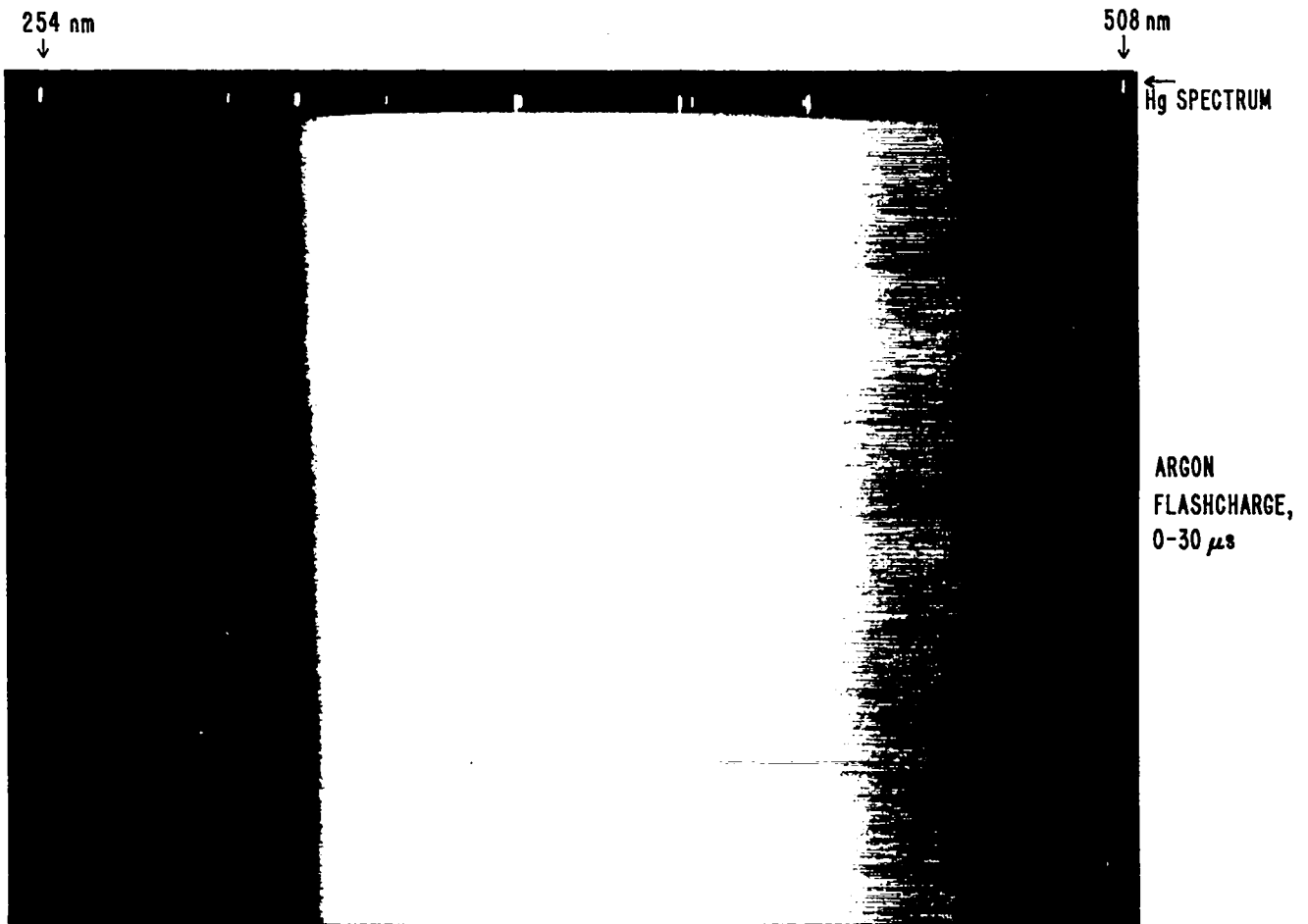
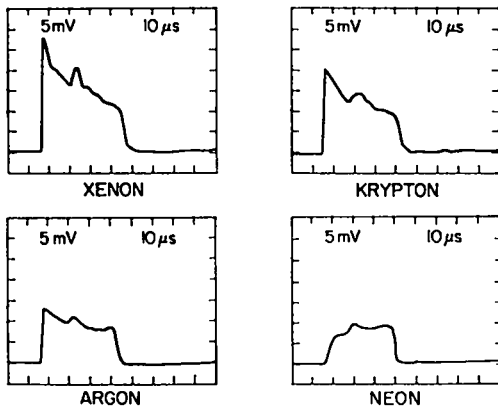

Fig. 8. Time-resolved spectrogram of argon flash-charge emission. Spectral coverage is 250-500 nm with Hg atomic lines included at top. Time covered is ~0- to 30- μ s portion of light output.

UV PULSES FROM
RARE GAS FLASH CHARGES
 $\lambda = 280 \text{ nm}$



ORDINATE: $L_{\lambda} \approx 1 \text{ kW-cm}^{-2}\text{-sr}^{-1}\text{-nm}^{-1}$ PER LARGE DIVISION

Fig. 9. Ultraviolet signals from flash charges containing xenon, krypton, argon, and neon.

TABLE II
RARE-GAS FLASH-CHARGE SUMMARY

Test Number	Rare Gas	Peak Temperature ^a	Cylinder Gas Purity	Purity of Gas From Shot
UV-7	Ar	25 kK	--	--
8	Ar	26	99.7%	99.8%
9	Xe	36	98.0%	98.3%
10	Kr	29	99.6%	99.6%
11	Ne	23	99.9%	99.0%
12	Ne	22	b	99.9%
13	Kr	31	b	99.3%
14	Xe	35	99.4%	99.2%

^a $\lambda = 280 \text{ nm}$.

^bThese samples from same cylinder as first test with this gas.

III. EXPERIMENTS ON CYLINDRICAL SHOCK WAVES

Measurements have been made on shock waves in argon gas driven by radial expansions from cylindrical explosions. The first subsection will discuss the apparatus and phenomenology of these tests. The second subsection will address the radiant emission from the cylindrical shock fronts.

A. Argon Shock Waves Driven by Radial Expansion of Cylindrical Explosive Charges

Three experiments have been done to obtain information about argon shock waves driven by cylindrical explosive charges. The expanding gases from a solid cylinder of explosive transfer a larger fraction of the explosive energy to the argon than plane-wave systems do, because in the cylindrical configuration the dense explosive gases

have less kinetic energy. Two of the experiments had the explosive initiated at one end of the long cylinder, and one experiment had the cylinder initiated along its central axis.

The first experiment was done because it was a small addition to an experiment being done for another purpose. The original experiment had a cylinder of explosive, initiated at one end, arranged along the axis of a much larger steel tube. The purpose of it was to study the motion of the tube. For our purposes, we closed the tube with a glass sheet and changed the gas from air to argon, with no deleterious effect on the results for the tube motion study. A diagram of the experimental arrangement is shown in Fig. 10. The explosive was PBX-9501, a plastic-bonded HMX composition with density 1.84 g/cm^3 , detonation pressure about 36 GPa, and detonation velocity $8.78 \text{ mm}/\mu\text{s}$. The cylinder was made up of 11 segments, each 50.8 mm diameter and 54.4 mm long, for a total length of 598.5 mm. The segments were glued together with careful alignment to make a

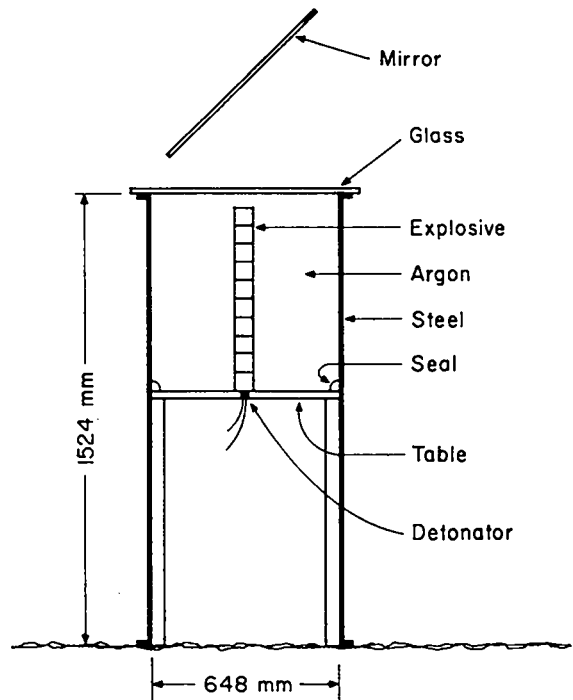

Fig. 10. Diagram of the shot assembly with a cylinder of explosive in a steel cylinder. The explosive is assembled from segments, each 50.8 mm dia. and 54.4 mm long; the joints cause perturbation in the flow.

uniform cylinder. The steel cylinder was 6.35 mm thick, and was 648 mm inside diameter and 1524 mm long. It was set on end on the ground, and a table about 900 mm tall was set inside it to hold the explosive. A glass sheet was placed on the top of the steel cylinder. The table was fitted with rubber to seal it to the cylinder. The explosive was aligned on the axis of the cylinder, and the top end of the explosive was about 25 mm from the glass plate. A square-shaped large mirror, 600 mm on a side, was placed above the glass at 45° to reflect light from the shock wave to the cameras. The initiator and cabling came up through the table. Argon was flowed through the closed upper section of the tube at a rate of 1.2 cfm for 40 minutes to replace all the air with argon, forcing it out between the top flange and the glass sheet. The flow was maintained through the detonation time.

The light from the conical shock wave in the argon gas was reflected from the overhead mirror to the bunker and through a beamsplitter to two separate image-intensifier cameras. One camera photographed the shock at 60.02 μ s after detonation, and the other at 69.99 μ s. The later photograph is shown in Fig. 11. The print was made to accentuate brightness differences, and the light is dimmer at the edges where the shock becomes weaker. The print also shows poorly defined rings; these arise from the slight imperfections where the segments of the explosive cylinder are joined. The presence of the rings allows some analysis of the photograph, because they allow for tracking those points. From earlier work (particularly shot number C-3159), it was known that the argon shock made an angle of about 42° with the cylinder axis, and that the marked points moved out on a line making an angle of about 55° with the axis. The points measured from both photographs are shown in Fig. 12. The times that the pictures were taken, and the known detonation velocity, give the position of the detonation wave. The limit of luminosity at the outer edge of the shock gives an approximate position for the shock near the initiation end of the charge. These data give reasonable agreement with expectations, and show that even slow and weak shocks are still bright enough to be useful. The uniformity of the

image-intensifier tubes is not good enough for quantitative brightness measurement without careful calibration, and it is not attempted with these data. The initial shock velocity found here is 5.85 mm/ μ s, from $U = D \sin \theta$, where U is the shock velocity, $D = 8.75$ mm/ μ s is the detonation velocity in a 50-mm cylinder, and θ is the angle the shock makes with the axis.

The second experiment was similar to the first, but it was done especially to measure the shock brightness and velocity. The camera view was from the side instead of from the top, so the real shape of the shock could be recorded. There were two shots, UV-15 (C-5082) and UV-16 (C-5083), and two image-intensifier photographs are taken of each, so there are four records, and each record has two sides. The container for the argon was a plywood box, constructed in the shape of a cube approximately 600 mm on a side, with a glass window in one side. In addition to the camera records, the box had holes to allow ultraviolet light to reach detectors; these results are described separately. Photographs were taken at 50.0 and 70.0 μ s after detonation. One of the later photographs is shown in Fig. 13. The angle of the shock wave to the cylinder axis was measured along both sides of the picture in all the pictures. The shock shape is nearly steady (unchanging in time) for all but the outermost parts, and velocities can be obtained from the angles by using the steady detonation velocity (along the explosive stick), which is 8.75 mm/ μ s, in the equation $U = D \sin \theta$. The results are given in Table III. The distance in this table is the position behind the detonation front. By invoking the steady flow assumption, distance can be converted to time, and the velocity at that time used with the intensity vs time record from the stationary ultraviolet detector positioned on the centerline. The flow in the outermost parts is not steady, because it is driven by the first segment which has no explosive behind it (Fig. 12), and the scattering of readable points in the table shows where it deviates. The results are plotted in Fig. 14, where it is easy to see how the points from the nonsteady flow leave the smooth curve. The steady part is given by the least-squares fit

$$U = 1.138 \exp(-t/6.20) + 4.866 - 0.01632 t.$$

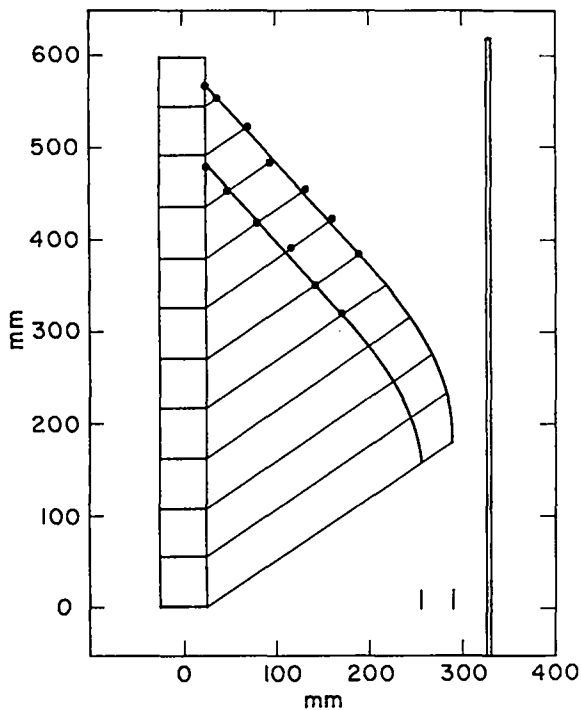

Fig. 12. Shock positions found by analysis of the photographs. Experimental points are measured positions of the perturbation rings seen in the shock wave. From other experiments done earlier, the shock angle was known to be about 42° initially, and the particle motion was known to make an angle of about 55° with the axis.

Integration gives

$$r = 7.056[1 - \exp(-t/6.20)] + 4.866 t - 0.00816 t^2.$$

The third experiment, UV-23, was similar to the first and second, but with an important difference. The cylinder of explosive was initiated along its axis, simultaneously, rather than from one end. The detonation wave propagated outward from the axis, and drove the argon gas in the direction of its own motion. This arrangement gives a much higher initial velocity to the argon shock, and, instead of being cone shaped, the shock wave is cylindrical.

Simultaneous axial initiation was obtained using a line-wave generator, diagrammed in Fig. 15. The explosive is an extrudable composition that is cured after extrusion so it becomes a stable, rubbery solid. It is held in a plastic form that has the spaces for the explosive tracks. It works because the detonation runs the same distance in each track, and thus arrives at the end, the line, at the same time at each point. Two line-wave generators were inserted into a groove cut into the axis of the explosive cylinder. The line-wave generators stick out of the cylinder, and therefore the shock wave is not a complete cylinder. We believe that the presence of the remains of the line-wave generators does not seriously perturb the remainder of the shock wave.

TABLE III
ARGON SHOCK VELOCITIES

Distance (mm)	Time (μ s)	Velocities (mm/ μ s)								Average (mm/ μ s)
0.0	0.00	5.99	6.12	5.90	6.17	5.90	6.12	5.80	6.07	6.01
50.8	5.81	5.20	5.25	5.16	5.25	5.15	5.19	5.16	5.16	5.19
101.6	11.61	4.86	4.94	4.83	4.94	4.87	4.88	4.84	4.85	4.88
152.4	17.42	4.63	4.60	4.62	4.73	4.63	4.65	4.66	4.66	4.65
203.2	23.22	--	--	4.44	4.54	--	--	4.52	4.50	4.50
203.2	23.22	4.11	4.18	--	--	4.21	4.24	--	--	4.19
254.0	29.03	--	--	4.32	4.34	--	--	4.32	4.31	4.32
254.0	29.03	--	--	--	--	3.21	3.12	--	--	3.17
304.8	34.83	--	--	4.06	3.90	--	--	--	3.94	3.97
355.6	40.64	--	--	--	3.51	--	--	--	3.44	3.48

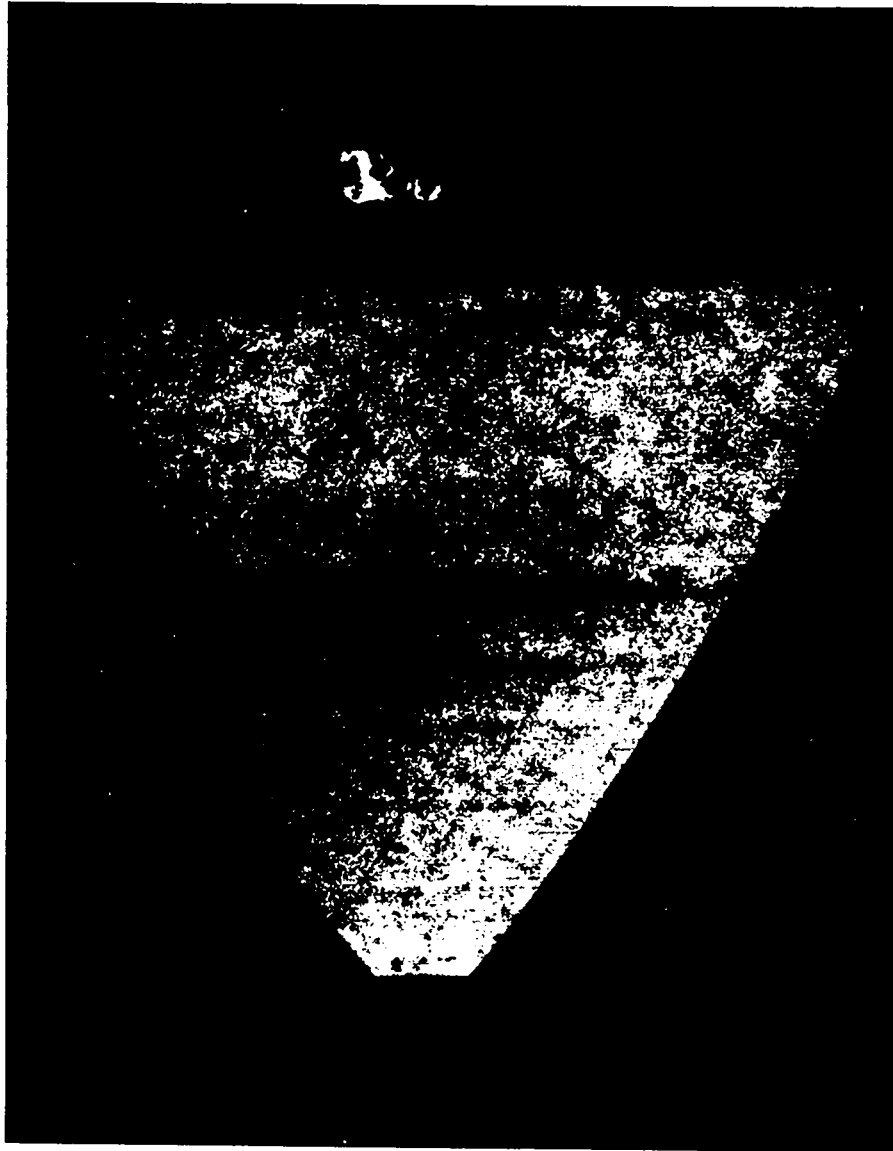

Fig. 13. Side view of light from the shock wave in argon driven by a cylinder of explosive initiated at one end. The perturbations caused by the joints in the charge are visible, but it can be seen at the edges that they cause almost no variation in the shock shape. The regular cross hatching is caused by the structure of the fiber-optics output plate of the camera tube. Shot No. C-5083-D. Test UV-16.

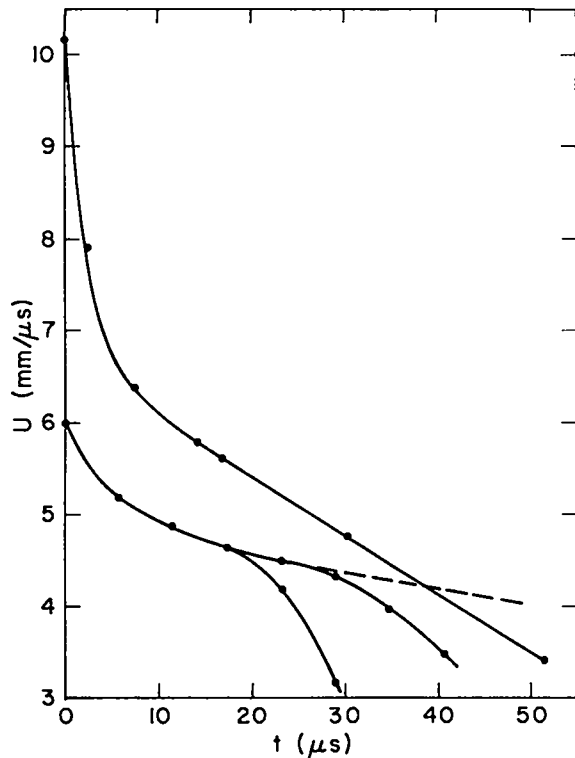

Fig. 14. Plot of shock velocity vs time for the second and third experiments. The lower curve is for the end-initiated second experiment. The points depart from a smooth curve where the flow has not yet become steady. There are two parts to it because there were photographs taken at two times. The upper curve is for the axially initiated third experiment. The outward-directed detonation wave gives a high initial shock velocity.

Two image-intensifier cameras were used to view the cylindrical shock wave, with a beamsplitter sending light from the same lens to each intensifier. A photograph taken at 16.74 μs after the detonation reached the surface of the explosive is shown in Fig. 16. The perturbation on the left in the picture was caused by the joint between the two line-wave generators. The additional perturbations in the right half arise from the early shocking of some of the explosive through the thin cover of the line-wave generators. These have been removed in later assemblies by adding a brass cover to the line-wave generator. The perturbation from the interaction of the two line-wave generators remains. The picture is printed at high contrast, so the perturbations are enhanced. The other image-intensifier camera was pulsed four times,

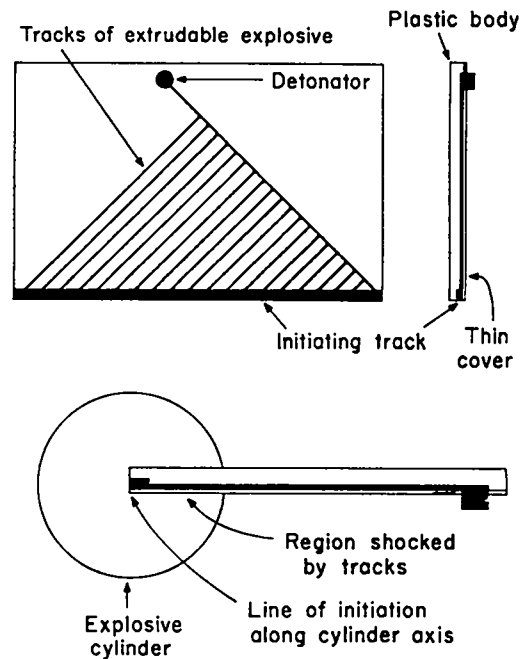

Fig. 15. Diagram of a line-wave generator, and end view of the axially initiated explosive charge. The line-wave generator is initiated at one point, and the detonation wave in the tracks of extrudable explosive runs the same distance in every track. The explosive is contained in the thick plastic form, and has only a thin cover over it.

giving a multiple exposure of the shock wave. The photograph is shown in Fig. 17. The times of the exposures were 2.23 μs, 7.23 μs, 14.20 μs, and 30.23 μs after the detonation wave reached the explosive surface. The time that the detonation wave reached the surface was detected by electrical switches on the surface; these also served to check that the wave reached the surface points nearly simultaneously. In addition to the camera records, the experiment also used photodetectors. The intensity rise at the instant the wave reached the wall of the box and reflected showed in the oscilloscope traces, and gave the time of that event. In all, then, there are five time-distance pairs from the photographs, one from the explosive surface switches, and one from the photodetectors. The values are given in Table IV. These data are well represented by the least-squares fit

$$r = 8.322[1 - \exp(-t/2.77)] + 6.679 t - 0.0318 t^2$$

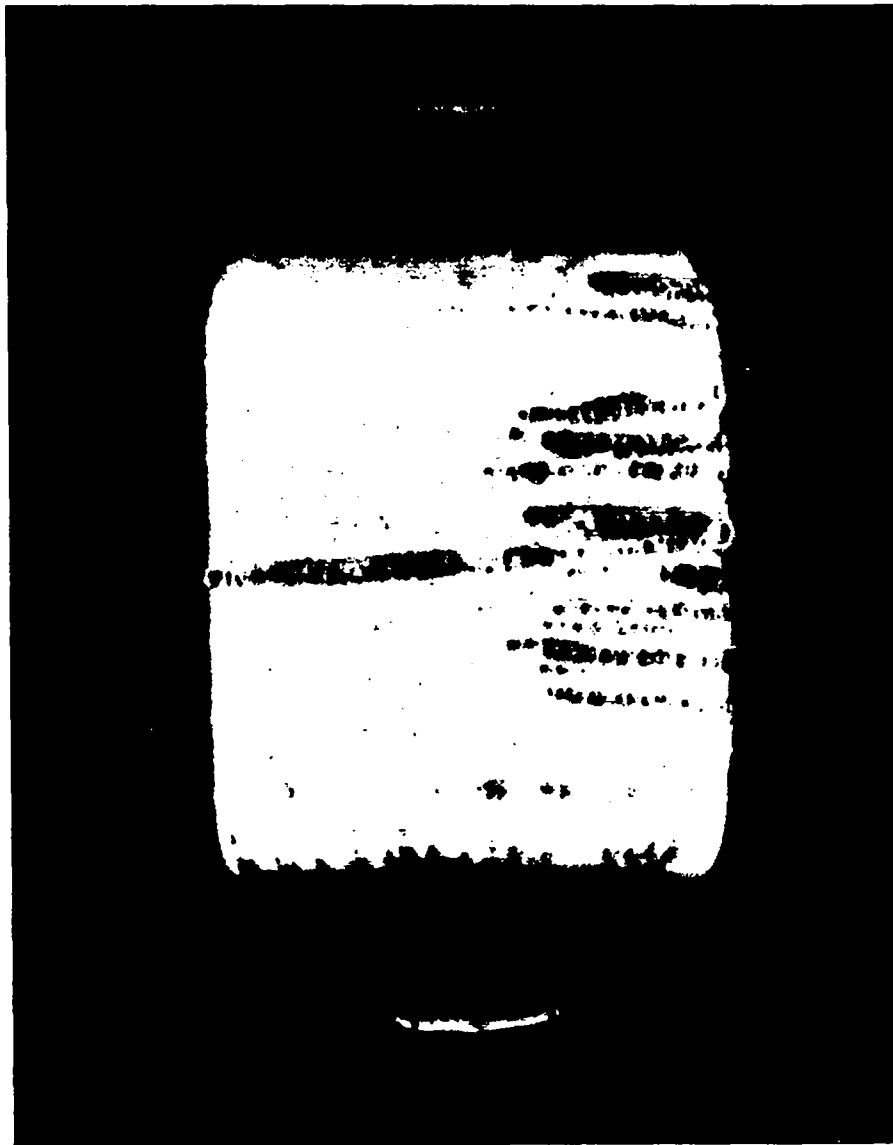

Fig. 16. Photograph of a cylindrically expanding shock wave. The perturbation on the left is caused by the interaction between the two line-wave generators. These extra ones on the right are caused by the shock transmitted through the thin plastic cover of the line-wave generator by the extrudable explosive. Shot No. C-5101-B. Test UV-23.

TABLE IV

DISTANCE-TIME VALUES FOR THE AXIALLY INITIATED CYLINDER

t (μs)	r (mm)	r _{calc} (mm)	μ_{calc} (mm/ μs)
0.0	0.0	0.0	10.18
2.23	19.6	19.8	7.91
7.23	55.1	54.6	6.39
14.20	96.6	96.7	5.78
16.74	110.6	111.2	5.62
30.23	181.6	181.2	4.76
51.15	266.7	266.8	3.43

This fit can be differentiated to get the velocity as

$$U = 3.50 \exp(-t/2.377) + 6.679 - 0.0636 t$$

The calculated values are also listed in the table. The form used for these fits was chosen by trial and error, and has no physical basis. The initial velocity seems too high, and reflects the difficulty of fitting where the curve is very steep. The velocity behavior is the upper curve in Fig. 14.

The curve of velocity vs time for the axially initiated explosive lies above the curve for end-initiated explosive. The shock wave is much stronger, initially, when the shock is driven in the direction the detonation was going. At late times, the curves would probably cross if the end-initiated explosive cylinder were long enough to be steady at those times. This is because the strong shock leaves more energy in the gas behind the radiating shock front, as it has been at a higher temperature and, even though it has expanded, it is still at a higher temperature.

Although it is well known that the expansion of gases from a cylinder forms additional shocks behind the main shock, these data do not show their presence. The photodetector data are also almost smooth, with only faint indications of any accelerations of the front. Apparently the extra shocks have little effect. The smooth fits given here seem to be adequate.

When the distance-time fits given here are used to calculate the radiating area, one must remember that the radial distance for them was measured from the explosive surface. The real radius is obtained by adding the radius of the explosive stick, 25.4 mm, to the distances given by the fit.

B. Ultraviolet and Visible Emission from Radially Expanding Shock Waves in Argon

The previous subsection has described non-radiometric measurements made on radially expanding shocks in argon. In the latter three of these tests, radiometers previously described were used to measure the temperature of the shock fronts.

In tests UV-15, 16 the end-initiated stick of HE and the resulting shock shown in Fig. 13 were observed by 280-nm radiometers through two holes bored in one wall of the plywood enclosure. These holes were at the appropriate height in the box wall such that the detectors viewed into the box near the midplane of the vertical explosive. One detector viewed through its hole at normal incidence to the surface of the HE cylinder. The other view line was parallel to this one but offset 18 cm horizontally from the first. That is, it observed the radial shock expansion obliquely.

The two signals from Test UV-16 are shown in Fig. 18. These traces began 20.0 μs after the trigger pulse to the detonator. The detector having the normal view of the HE stick shows the time required for the detonation wave to reach the height of the detector's field of view on the stick. The detector having the oblique view begins seeing light later because the shock front must also travel outward from the stick before reaching its field of view. [The "normal" and "oblique" are used for brevity; the normal view is colinear with a radial component of the expanding front. Since the front is conical over much of its area, the normal detector line of sight is at a vertical angle ($\sim 35^\circ$) to the shock front. The oblique detector is also at this vertical angle in addition to viewing obliquely to the radial component]. The slow upward ramp at early times in the normal view results from light scattered onto the detector from various parts of the box. The large bump on the tail of the other signal is due to the explosive fireball entering the field of view of this detector.

We have determined the temperatures observed by each detector during each test. The temperature changes with time during the test as shown in Fig. 18, so we have shown two temperatures for each light pulse. The temperatures are shown in

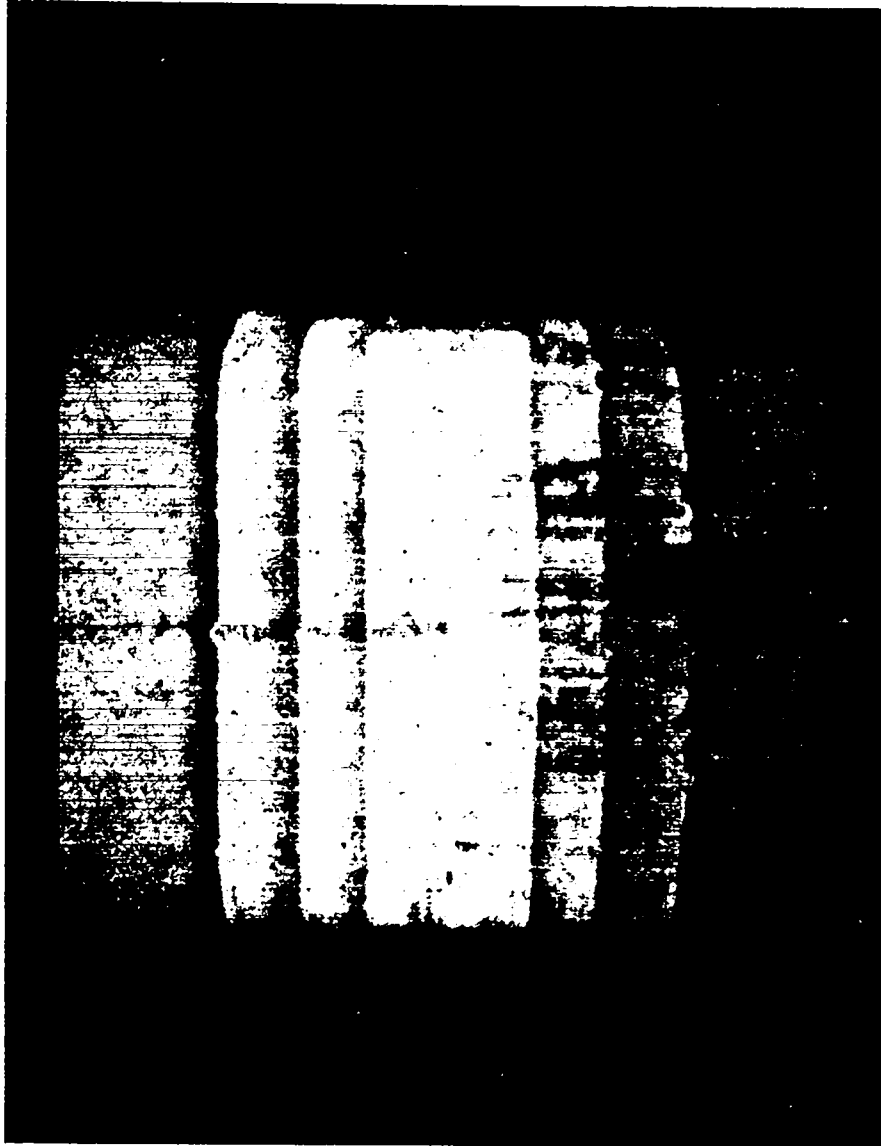

Fig. 17. Multiple-exposure photograph of the cylindrically expanding shock wave. These four superimposed photographs give the wave position at four precisely known times. Shot No. C-5101-D. Test UV-23.

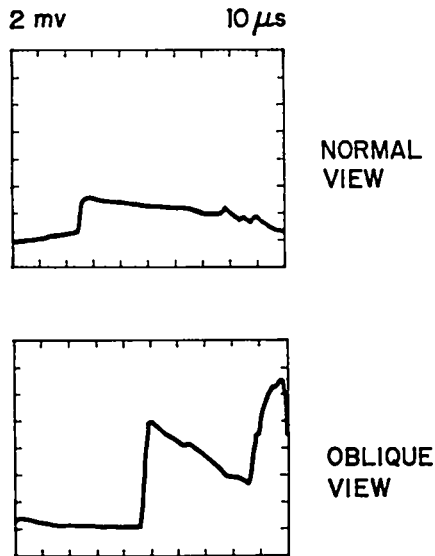

Fig. 18. Radiometer signals from Test UV-16 at $\lambda=280$ nm.

Table V, where time begins at the detonator trigger. (Remember that for UV-16, shown in Fig. 18, there is a 20- μ s delay). The first time listed for the normal incidence view corresponds to the peak of this light pulse, while the second time refers to the peak of the oblique-view detector. This time entry and the last one permit a comparison between the two views at the same time. These latter two times are 4 μ s earlier for UV-16 than for UV-15, apparently because of a small difference in the hole separations in the two enclosures.

Table V shows good agreement between the two tests for similar positions on the light pulses. The larger uncertainties for the later time entries for the normal-view detector are due to the uncertainty in the baseline position as discussed above.

The temperatures recorded here are less than the 25-kK values for planar geometries because the shock velocity is considerably less in this end-initiated, radially expanding configuration. In this case the initial shock velocity was measured to be 6 mm/ μ s compared with 9 mm/ μ s in the planar case (with argon). Azimuthal symmetry, shown to apply to these shocks in Fig. 11, suggests that for times at which both detectors see the shock front, the measured temperatures should be equal. Table V shows that this is not the case. The 2,000- to

TABLE V
RADIAL-SHOCK TEMPERATURES AT VARIOUS TIMES

Test	View	Time*, μ s	Temperature, K
UV-15	Normal	48	18,500 \pm 500
		74	16,600 \pm 1300
		98	15,000 \pm 1700
	Oblique	74	14,700 \pm 200
		98	12,100 \pm 200
		98	12,100 \pm 200
UV-16	Normal	48	18,500 \pm 500
		70	16,800 \pm 1200
		94	14,200 \pm 1300
	Oblique	70	14,300 \pm 200
		94	10,800 \pm 200
		94	10,800 \pm 200

* Time elapsed between trigger pulse to detonator and reading of radiometer signal.

3,000-K lesser temperature for the oblique view may be due to the longer argon pathlength or a wall interaction layer for that detector. If the shock is emitting as a perfect blackbody, the radiance, and therefore temperature, should be independent of the angle of incidence at which the detector views the shock front.

In Test UV-23 the explosive charge and enclosure were similar to those just described. However, the cylindrical explosive was simultaneously initiated along its axis resulting in a shock front of cylindrical shape. Radiometers calibrated at $\lambda = 280$ nm and $\lambda = 520$ nm monitored the expanding shock normal to its surface. The resulting signals are shown in Fig. 19.

From these radiometer signals we can determine the shock front temperature at various times during its travel to the enclosure walls. These data may be combined with the velocity values from Table IV for a plot of brightness temperature vs shock velocity shown in Fig. 20. Temperatures corresponding to faster motion of the shock exhibit good agreement between the two wavelengths and to the similar temperatures measured for the 9-mm/ μ s shocks in planar argon shocks. The increasing discrepancy between the measurements at the two wavelengths with decreasing shock velocity is puzzling and unexpected. It is reasonable to speculate that, because of the time sequence of the points in Fig. 20, the faster reduction in the uv temperature with shock velocity

**RADIATION FROM CYLINDRICAL SHOT
LWG INITIATION**
2" ϕ x 30" LONG 9501 IN 2' CUBICAL BOX

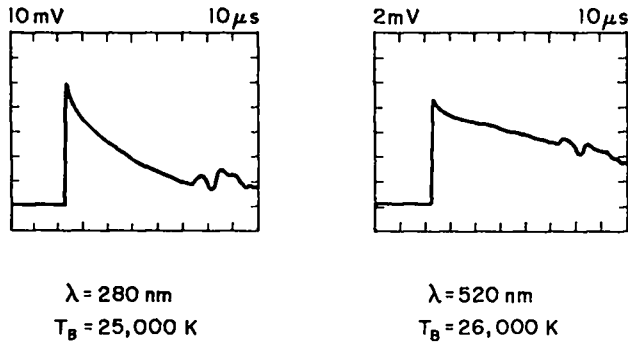

Fig. 19. Radiometer signals at $\lambda = 280$ and 520 nm from Test UV-23.

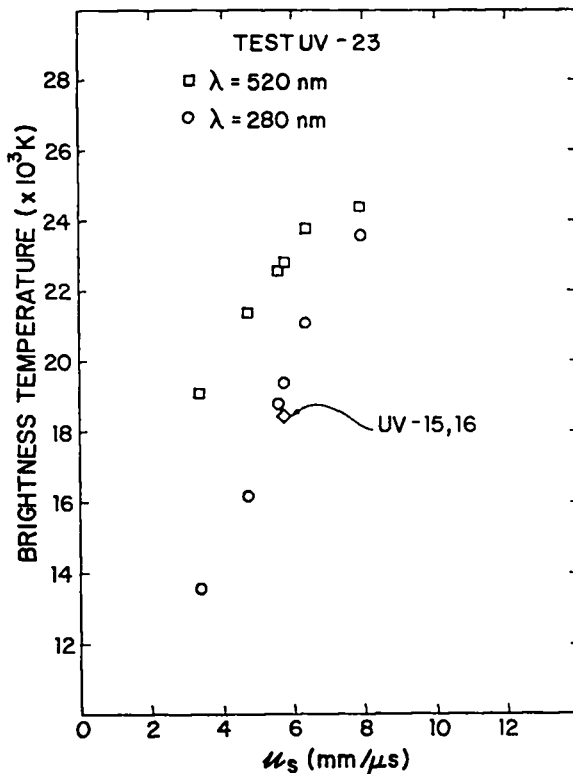

Fig. 20. Dependence of the brightness temperature on the shock velocity for a cylindrically expanding shock wave in argon gas. With the exception of point marked otherwise, the data are from different times of expansion in Test UV-23. See Table IV and Fig. 19.

may be due to a light-induced absorption process occurring between the shock wave and the detector. Since there was no window over the enclosure aperture through which the source was observed, vacuum ultraviolet radiation may have created absorbing species (e.g., excited oxygen or ozone) in the air path.

Further examination of the radiating properties of the expanding shock front is instructive. In Table VI the shock radius, area, and measured temperature are tabulated for various times, along with the total radiant emittance (σT^4), the spectral emittance for $\lambda = 280 \text{ nm}$, and these latter two quantities integrated over the shock front area. Since the length of explosive was 30 cm , this value was used in computing the radiating area. While Fig. 16 shows that in this test many disturbances reduce the effective shock area, we are assuming that more sophisticated initiation techniques would eliminate these cooler regions and allow uniform emission from the full cylindrical surface.

Since the temperature drops as the shock expands, both M and M_λ must fall also. However, the total radiated power from the total shock surface rises as the shock expands up through at least $t = 30 \mu\text{s}$. The spectral emittance at $\lambda = 280 \text{ nm}$ rises even faster and continues to do so through at least $50 \mu\text{s}$ where it apparently is close to peaking.

An approximate time integration over the pulse of Fig. 19 shows a total radiated energy of this source to be $\sim 2 \times 10^5 \text{ J}$ during the first $50 \mu\text{s}$. The explosive energy release from this quantity of 9501 high explosive is known to be $5 \times 10^6 \text{ J}$. The radiation yield is then 4%. The yield into specified bands within the radiation spectrum can be similarly determined. The greater mechanical coupling of the explosive energy to heavier gases indicates that a significantly greater efficiency would be realized. The data of Table II combined with the σT^4 relationship for a blackbody radiator suggests that a radiation yield of 16% is expected for a cylindrical shock wave in Xe.

TABLE VI
RADIOMETRIC PROPERTIES OF CYLINDRICAL SHOCK SURFACE

UV-23							
$t, \mu\text{s}$	r_s, cm	A_s, cm^2	T, kK^a	$M = \sigma T_s^4$	M_λ^c	$A_s \sigma T_s^4$	$A_s M_\lambda$
		$2\pi r_s^2$		$W - \text{cm}^{-2}$	$W - \text{cm}^{-2} - \text{nm}^{-1}$	W	$W - \text{nm}^{-1}$
0+	2.54	479	26.2	2.67×10^6	3.56×10^3	1.28×10^9	1.70×10^6
7.23	8.05	1517	24.8	2.15×10^6	3.13×10^3	3.25×10^9	4.75×10^6
14.20	12.2	2300	22.8	1.53×10^6	2.55×10^3	3.52×10^9	5.87×10^6
30.23	20.7	3902	21.4	1.19×10^6	2.17×10^3	4.64×10^9	8.45×10^6
51.15	29.2	5506	19.1	7.55×10^5	1.58×10^3	4.16×10^9	8.71×10^6

^aTemperature measured by $\lambda = 520$ radiometer.

^bTotal radiated power per square centimeter, emittance, of shock surface.

^cSpectral emittance at $\lambda = 280$ nm.

IV. DISCUSSION AND COMPARISON WITH OTHER RESULTS

Optical radiation from shock fronts has been investigated both experimentally and theoretically for several decades. Zel'dovich and Raizer in their textbook⁶ discuss this subject in some detail, with particular emphasis on shock waves in air. Of interest here is that for shock waves of the strength used in our studies the front radiates as a blackbody. They also treat in detail the phenomenon of the preheating layer. This layer lies in front of the radiating shock front and attenuates the light on its path to the detection system. Hard ultraviolet radiation, from sufficiently hot shock fronts, induces opacity in the otherwise cold gas through photoionization, photoexcitation, and photochemistry in this layer. Screening of the shock front from the detectors therefore occurs, whose magnitude increases strongly with shock velocity and which depends also upon the gas and wavelength being observed. For example, in air strong screening occurs for shock temperatures in excess of 90,000 K,⁶ beyond which the optically measured brightness temperature is substantially less than the true temperature behind the front.

It is well known that the absorption of oxygen begins at 186 nm and extends downward into the harder ultraviolet. For the brightness temperatures of ~25 kK measured in our experiments, the emission peak of the corresponding blackbody radiation occurs at a $\lambda = 116$ nm. At this wavelength the absorption coefficient of air⁶ is $\sim 120 \text{ cm}^{-1}$. For experiments conducted here without a window

over the source aperture, light-induced phenomena in the air path are expected. This is the likely source of absorption bands observed in the time-resolved spectra reported in Section II.

Zatsepin et al.⁷ have measured the luminescence of shock fronts in air, argon, and xenon over a large range of shock velocities. Brightness of the fronts was observed at 330, 430, and 560 nm and at angles of incidence to the shock front of 90° and 45°. One important result from this work was that at higher velocities the normal-incidence radiation usually indicated a significantly higher temperature than the 45° radiation. In this respect, our results of Table V are consistent with theirs. They ascribe this behavior to the greater pathlength through the absorbing preheating layer for the oblique path. According to their results at lower velocities, however, the opacity of the preheating layer should be insufficient to affect this difference at our velocities. However, they do point out that for longer light pulses the screening layer can be more absorbing. The duration of our light pulses appears to be much longer than theirs, so a screening layer could have been responsible for the temperature differences in Table V.

Available data for shock waves in argon are plotted in Fig. 21. The ultraviolet points from Ref. 7 are shown along with Soviet theoretical predictions. Also included are data points from this work and theoretical curves of Kerley.⁸ A single data point from each of the works of Zinn et al.,¹ Model,⁹ and Kiselev and Krokhin¹⁰ is also

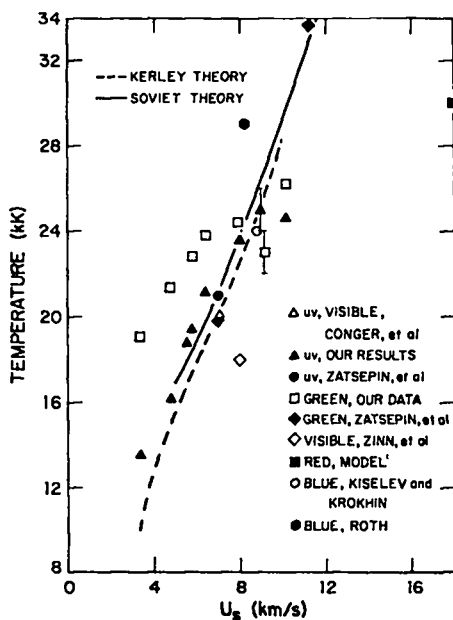

Fig. 21. Measured and theoretical brightness temperatures of shock fronts in argon gas as a function of shock velocity. Our points are from cylindrical expansions (UV-23), except for those points with error bars that represent averages of planar shock results.

plotted. The experimental points from Zatsepin et al. are in excellent agreement with Soviet equation-of-state theory up to shock velocities of 14 km/sec, where subsequent departure from theory is attributed to the screening layer. Our ultraviolet data are in very good agreement with Soviet theory. Our 520-nm data show substantial departure from the Soviet curve in Fig. 21. We do not know why our 520-nm points are above the curve for the cylindrical tests and below it for the average of planar shocks. For both visible and uv, our data indicate a fall-off from the trend for the higher velocities. Zatsepin et al. do not observe this fall-off until velocities of 15 km/sec are reached. The data point from Model' in Fig. 21 represents a large departure from theory.

In Fig. 22 available brightness temperature data for xenon are shown along with theoretical curves. Most of the points are from Zatsepin et al. recorded at $\lambda = 430$ nm. One point each from our work and from Model' is included. It is thought that the screening layer is responsible for most of the points lying below the curve.⁷ Again, however, our results agree rather well with those

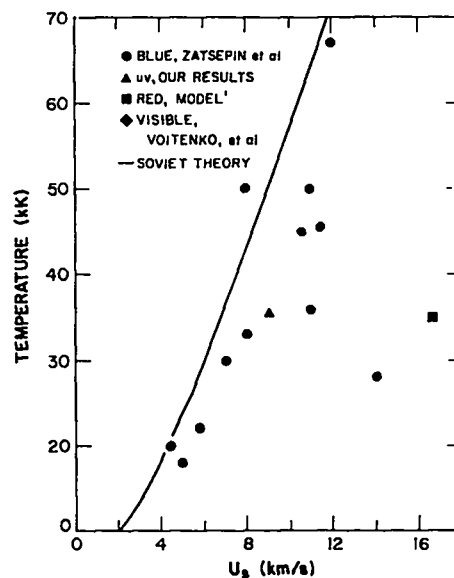

Fig. 22. Measured and theoretical brightness temperatures of shock front in xenon gas as a function of shock velocity. Our datum is from planar shock wave studies.

from Ref. 7. Kerley's theory⁸ is in excellent agreement with our results. He also computed temperatures for argon at $\rho_0 = 0.006$ gm/cc density (~ 4.6 local atmospheres), obtaining $\sim 10\%$ higher temperatures near 9 mm/ μ s shock velocities than at 1 atm. This result also agrees with our data, shown in Fig. 7.

Other rare gases have been investigated, but less extensively. Model' reports⁹ a temperature of 34 kK for a 17.2-km/sec shock wave in krypton. Roth¹¹ measured 38 kK for a velocity of 8.3 km/sec, somewhat higher than our value of 30 kK. Tsikulin and Popov¹² report a temperature of 32 kK at $\lambda = 280$ nm and at a velocity of 8-9 km/sec. Our value, obtained at that wavelength and similar shock velocity, is in good agreement with this result.

For neon, also, the measurements of Tsikulin and Popov¹² are in very good agreement with our results, shown in Table II.

In Section II, we reported measurements showing that 10% C_3F_7I added to argon gas did not affect significantly the brightness temperature of a shock through the mixture. We were somewhat surprised that the molecular species, having a large specific heat, did not cool the gas, or alternatively affect the preheating layer.

Zatsepin et al.⁷ observed that a 5% air admixture to argon greatly reduced the brightness temperature of the shock front at velocities above 10 mm/ μ s.

V. SUMMARY AND CONCLUSIONS

High explosives have been used to shock-heat rare gases to measured brightness temperatures up to 36,000 K. The area of the radiating shock fronts was large in both the planar and cylindrical geometries used. Close agreement between temperatures measured at both ultraviolet and visible wavelengths indicates that the sources are blackbody radiators. The continuous nature of the emission spectrum of the shockfront supports this conclusion.

The planar shocks reported here had radiating areas of 75 cm². Shock waves through argon gas were studied extensively. At a local one atmosphere the temperature measured for the emission from an argon shock at its peak velocity of 9 mm/ μ s was 25 kK. At six times this pressure, the measured temperature was approximately 10% higher. Up to 50 torr of a rather large molecule, C₃F₇I, did not affect the temperature of the shock for 1 atm argon.

Substitution of other rare gases into the shock tube resulted in some measured emission signals that are proportional to the square root of the atomic weights. For Xe a peak temperature of 36 kK was measured.

In radially expanding shock waves, stable large-area fronts in argon were observed. The temperatures and profiles of shock fronts were measured using two initiation schemes. Temperature and velocity as a function of time were determined and compared with results of other research.

For the axially initiated explosive, a cylindrical shock wave having an area beginning at 480 cm² and expanding to 5500 cm² was studied. During this expansion, the temperature fell from 26 kK to 19 kK, but the area-integrated radiation from the front continued to rise over the full 50- μ s observation time. The total optical

energy radiated according to a blackbody calculation was 2×10^5 J for an explosive energy to optical energy yield of 4%. Greater efficiencies using xenon can be expected.

REFERENCES

1. J. Zinn, W. C. Davis, T. R. Schwartz, R. C. Anderson, and W. D. Gould, "Theoretical and Experimental Studies of Strong Shock Waves in Air," Proceedings of the DNA Atmospheric Effects Symposium, San Diego, April 1973.
2. R. G. Shreffler and R. H. Christian, "Boundary Disturbances in High-Explosive Shock Tubes," *J. Appl. Phys.* **25**, 324-331 (1954).
3. The calibration procedure for the 280-nm detector is described in Internal Memorandum AP-2-80:240. The 520-nm radiometer was calibrated in a similar fashion against a quartz-halogen standard lamp.
4. B. Brixner, "Rotating-Mirror Sweeping-Image Spectrograph," *Rev. Sci. Instr.* **38**, 287-288 (1967).
5. E. D. Loughran, WX-2, used a mass spectrometer to quantitatively analyze samples obtained from each flash charge just prior to firing the shot.
6. Ya. B. Zel'dovich and Yu. P. Raizer, Physics of Shockwaves and High-Temperature Hydrodynamic Phenomena (Academic Press, New York, 1966).
7. Y. A. Zatsepin, E. G. Popov, and M. A. Tsikulin, "Luminance of Shock Wave Fronts in Certain Gases," *Sov. Phys. JETP* **27**, 63-66 (1968).
8. G. Kerley, X-7, Unpublished Los Alamos Results (1982). He used ionization equilibrium theory described in LA-8062.
9. I. Sh. Model', "Measurement of High Temperatures in Strong Shock Waves in Gases," *Sov. Phys. JETP* **5**, 589-601 (1957).
10. Yu. N. Kuselev and V. Z. Krokhin, "Measurement of Radiation from Strong Shock Waves in Gases Using Low-inertia Pyroelectric Detectors," Translated from *Fiz. Goreniya i Vzryva* **12**, 956-959 (1976).
11. J. Roth, "Measured Temperatures of Strong Shock Waves in Argon," *J. Appl. Phys.* **35**, 1429-1433 (1964).
12. M. A. Tsikulin and Ye. G. Popov, Radiating Properties of Shock Waves in Gases (Nauka, Novosibirsk, 1977).

Printed in the United States of America
Available from
National Technical Information Service
US Department of Commerce
5285 Port Royal Road
Springfield, VA 22161

Microfiche (A01)

Page Range	NTIS Price Code	Page Range	NTIS Price Code	Page Range	NTIS Price Code	Page Range	NTIS Price Code
001-025	A02	151-175	A08	301-325	A14	451-475	A20
026-050	A03	176-200	A09	326-350	A15	476-500	A21
051-075	A04	201-225	A10	351-375	A16	501-525	A22
076-100	A05	226-250	A11	376-400	A17	526-550	A23
101-125	A06	251-275	A12	401-425	A18	551-575	A24
126-150	A07	276-300	A13	426-450	A19	576-600	A25
						601-up*	A99

*Contact NTIS for a price quote.

Los Alamos