

Blast Effects of High Explosive Charges Detonating in Cylindrical Steel Tubes

Manfred Held*

TDW-Gesellschaft für verteidigungstechnische Wirksysteme mbH, D-86523 Schrobenhausen (Germany)

Blast Effekte von detonierenden Sprengladungen in zylindrischen Stahlrohren

Tests von zylindrischen Sprengladungen mit einem L/D-Verhältnis von 2, die zentral in Stahlrohren mit verschiedenen Radien und Wandstärken gesprengt wurden, werden mit ihren Zerstörwirkungen gegenüber den Stahlrohren beschrieben. Die Ergebnisse können mit analytischen Gleichungen erfaßt werden. Für einen Schutzbehälter mit minimalem Gewicht sollte ein möglichst großer Radius genommen werden, da die notwendige Wandstärke des Rohres quadratisch mit dem Radius und damit das notwendige Gewicht für das Stahlrohr linear mit dem Rohrradius abnimmt.

Effets de souffle de charges explosives détonantes dans des tubes en acier cylindriques

On décrit des tests effectués avec des charges explosives cylindriques, de rapport longueur/diamètre 2, détonant au centre de tubes en acier de rayons et d'épaisseurs de paroi différentes ainsi que les effets destructeurs sur ces tubes en acier. Les résultats peuvent être décrits par des équations analytiques. Pour un conteneur de protection de poids minimal, on doit choisir le rayon le plus grand possible, étant donné que l'épaisseur de paroi de tube nécessaire diminue quadratiquement avec le rayon et que le poids nécessaire du tube en acier diminue donc linéairement avec le rayon du tube.

Summary

Described are tests of cylindrical high explosive charges with an L/D ratio of 2, centrally detonating in steel tubes of different radii and wall thicknesses to measure the bulge respectively the damaging effects of these steel tubes. The results can be described with analytical equations. For a protecting container with minimum weight the radius should be as large as possible, because the necessary tube wall thickness is quadratically decreasing and therefore the weight of the tube is linearly decreasing with increasing tube radius.

1. Introduction

The efficiency of internally detonating high explosive charges in closed or partially closed containers is still a widely open field. The author made a number of tests in the 1960ies which are to date at least partially interesting for predictions and can be used to validate numerical simulations.

The results were also once published in a German technical magazine⁽¹⁾ which is no more available. Attending different conferences and meetings the author found out that these results could be made available again now for younger people coming into the field of weapon effectiveness and especially of protecting systems.

2. Test Layout

For the tests, cylindrical charges were used with weights from 5 g on up to 1 kg and with a length to diameter ratio of 2 of cast TNT/RDX (35/65) with the density of about

1.7 g/cm³. They were initiated at the center of one end-surface with a booster of pressed RDX/Wax/Graphite (96/5/1), 8 mm diameter and 15 mm length. They were installed and detonated in the axis of seamless steel tubes of 27 mm radius and 3 mm wall thickness up to 195 mm radius and 7 mm wall thickness (Fig. 1). In every tube 3 to 4 charges were fired with increasing charge weight and the bulging or degree of damage was determined. Examples of the different damage results are shown in Figure 2 where the relatively small bulge of the tube was declared to be 10% damage, where it is partially opened to be 40% and where it was remarkably pedaling to be 80% damage. The results which were achieved with the degree of damage η for the six investigated steel tubes over the charge weights W are shown in a logarithmic scale in Figure 3. The achieved results in this logarithmic diagram can be described with the degree of damage η to be roughly the exponent of 0.5 with increasing charge weight or inversely, to be increasing with the charge weight with the exponent of 2.

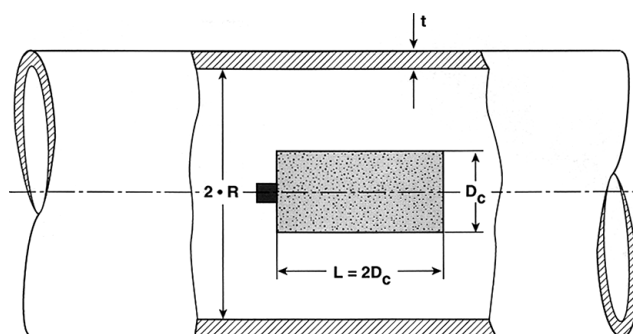

Figure 1. Principle test setup.

* Corresponding author; e-mail: manfred.held@tdw.lfk.dasa.de

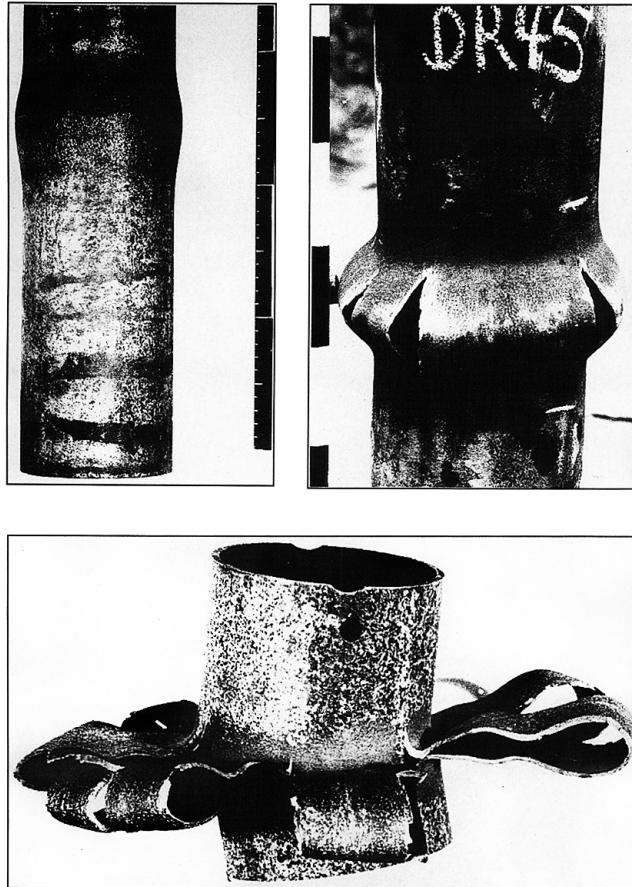

Figure 2. Examples of bulged or damaged steel tubes with 10%, 40% and 80% damage.

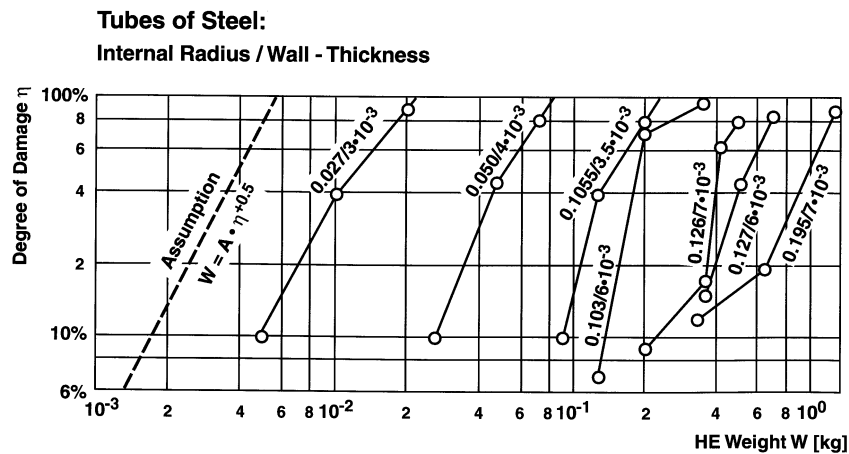

Figure 3. Degree of damage η as a function of the high explosive weight W against different steel tubes (first number: internal radius in meter, second number: wall thickness in meter).

$$W = A \cdot \eta^{0.5} \tag{1}$$

or

$$\eta = (1/A) \cdot W^2 \tag{1a}$$

In this diagram typically the last two values are extrapolated to the 100% values if an experimental result with 100% damage was not available. But just these 100% values are mainly considered in the follow-on analysis. The internal radius R for 100% damage as a function of the high explosive

charge weight W with the wall thickness t as parameter is presented again in a logarithmic scale (Fig. 4). Through all 5 different wall thickness values parallel lines can be drawn which can be expressed by Eq. (2):

$$W = B \cdot R^{1.72} \tag{2}$$

From Figure 4 the wall thickness t for a constant internal radius R can be selected as a function of the necessary charge weight W , again for 100% damage. The data selected from Figure 4 for the internal radius $R = 0.1$ m are drawn in Figure

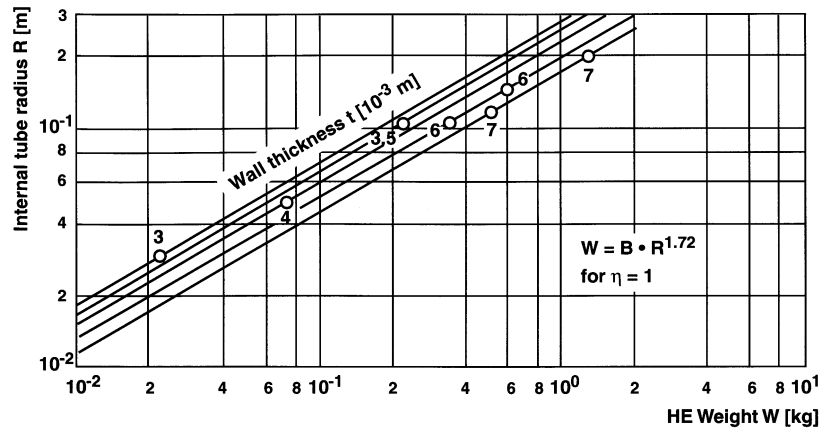

Figure 4. Steel tube radius R as function of the high explosive mass W for 100% damaged or destroyed steel tubes with the wall thickness t as parameter.

5. This straight line in the logarithmic diagram can be described with Eq. (3):

$$W = 0.076 \cdot (t \cdot 10^3)^{0.86} \tag{3}$$

This Eq. (3) is valid just for the radius $R = 0.1$ m and $\eta = 1$.

Now all the parameters can be combined in “one” equation for the necessary charge weight W to obtain some damage η in a steel tube of internal radius R with the wall thickness t .

$$W = 4 \cdot (10^3 \cdot t)^{0.86} \cdot R^{1.72} \cdot \eta^{0.5} \tag{4}$$

This universal equation can be used for new diagrams. As an example, the necessary radius R of the steel tubes as a function of the charge weight W with the steel tube thickness t as parameter for a small damage of $\eta = 0.1$ is shown in Figure 6, which is a graphical presentation of Eq. (5).

$$W = 1.26 \cdot (10^3 \cdot t)^{0.86} \cdot R^{1.72} \tag{5}$$

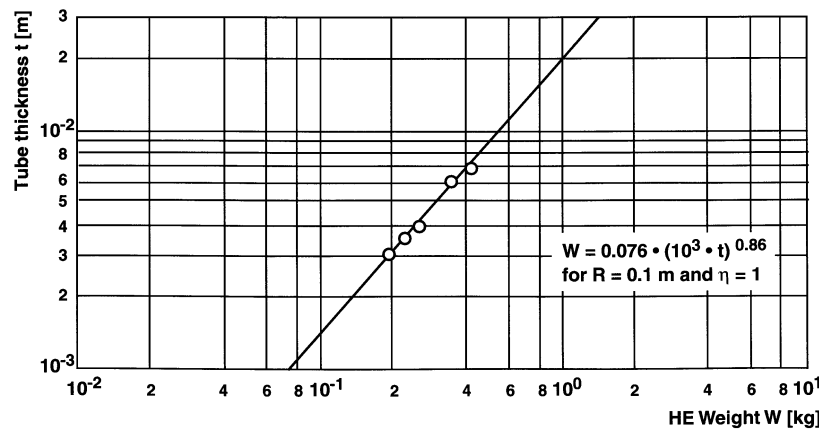

Figure 5. Wall thickness t as function of the high explosive weight W at an internal tube radius $R = 0.1$ m.

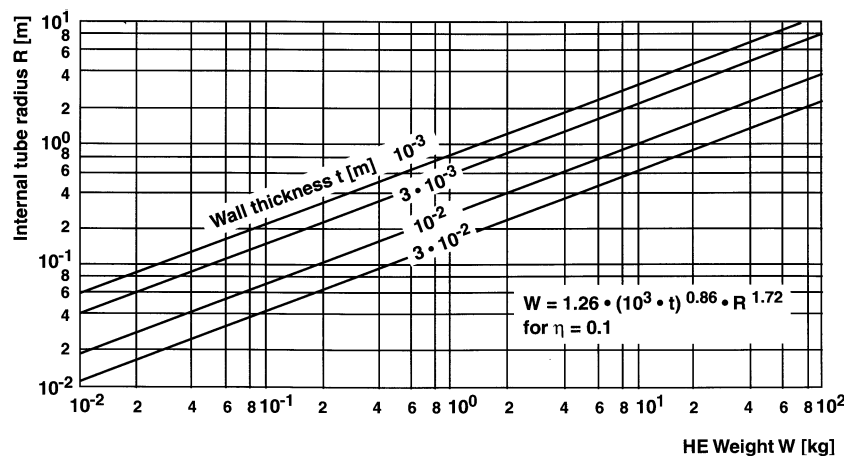

Figure 6. Necessary internal tube radius R in m as a function of high explosive weight W in kg with the tube thickness t in m as parameter with a damage of $\eta = 0.1$.

But generally more interesting is the internal radius R as a function of the degree of damage η , tube thickness t and especially charge weight W . The Eq. (4) can be transferred to Eq. (6)

$$R = 0.447 \cdot \eta^{-0.291} \cdot W^{0.58} \cdot (10^3 \cdot t)^{-0.5} \quad (6)$$

As an example, the necessary internal radius R can be presented as a function of wall thickness t with the charge weight as parameter for again a relatively small bulging of the steel tube with $\eta = 0.1$ which gives the Eq. (7) and which is graphically drawn up in Figure 7.

$$R = 0.875 \cdot W^{0.58} \cdot (10^3 \cdot t)^{-0.5} \quad \text{for } \eta = 0.1 \quad (7)$$

This equation gives a very good indication for designing protecting tubes with regard to minimum weight for the same degree of damage or bulging of the tube. With a linearly increasing internal radius the weight is linearly decreasing for the cylindrical tube, not taken into account any cover plates on the end surfaces of the tube. Using an example of Figure 7 and selecting a protection against a 2 kg charge with a degree of damage η of 0.1, a wall thickness of 1.7 mm is needed for 1 m radius, and for a radius of 0.1 m, a wall thickness of 170 mm is needed which means hundred times thicker and therefore, a 10 times higher weight is necessary for the same protection by using a 10 times smaller internal radius for the container.

The mass of a tube M_{tube} is given by

$$M_{tube} = \pi \cdot (2 \cdot R + t) \cdot t \cdot \rho \cdot L \quad (8)$$

respectively for $2R$ much larger than t

$$M_{tube} = 2 \cdot \pi \cdot R \cdot t \cdot \rho \cdot L \quad (8.1)$$

The length of the tube should be equal for this comparison or the values are considered per unit length.

The maximum pressure p_{max} is a function of the charge weight given by the scaling law⁽²⁾ with the cubic root

$$p_{max} \approx W^{1/3} / R \quad (9)$$

or for a constant maximum overpressure p_{max}

$$R \approx W^{1/3} \quad (9.1)$$

The impulse is presented by this scaling law with

$$I \approx W^{2/3} / R \quad (10)$$

or for constant impulsive load for different radii

$$R \approx W^{2/3} \quad (10.1)$$

In the presented experiments the exponent is 0.58 for the charge weight W . This value is just a little below the impulsive load exponent alone with $2/3$ or 0.67.

As a result of many tests especially against aircraft structures a square root dependence was found for the charge weight W as a function of distance for a constant damage level

$$R = C \cdot W^{1/2} \quad (11)$$

which corresponds also very well to the damage of shock waves of underwater detonations⁽³⁾.

These data can be now graphically presented and compared with the detonation results in the steel tubes which are shown in Figure 8 where different constants or “C”-values are used as parameter values. The lines in this logarithmic scale deviate a little, because the exponents to the charge weight are slightly different. In this diagram results of a World War II “soft” airplane—He 111—are added, which are taken out from the ISL damage diagram⁽²⁾ by the author and which can be fitted with the distance-charge weight equation to

$$R_{He} = 1.42 \cdot W^{0.69} \quad (12)$$

which means the damage is created only by the impulse or momentum transferred to the target by the blast wave of a detonating high explosive charge. The exponent of the charge weight should not exceed the value of 0.67. But the small difference can arise from the analysis of the test results. Also the exponent 0.58 for the deformation of the mild steel tubes demonstrates that the damage is primarily caused by the impulse at these very short distances transferred by the products of the detonating high explosives rather than by the maximum overpressure.

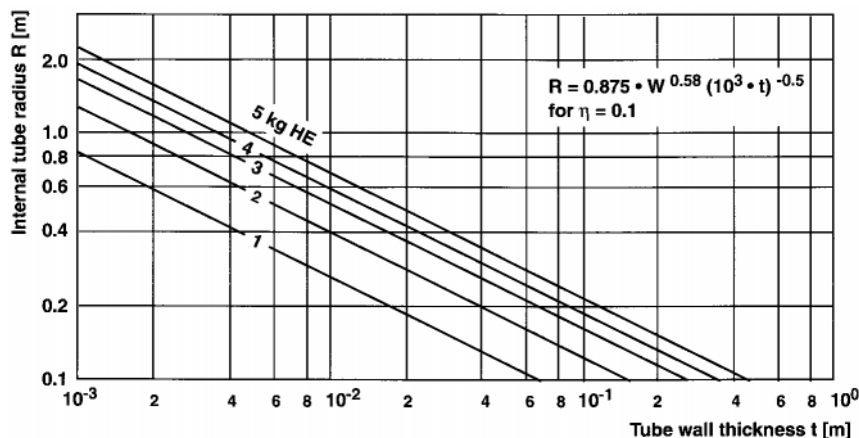

Figure 7. Necessary internal tube radius R as a function of steel tube thickness t with the high explosive mass as parameter.

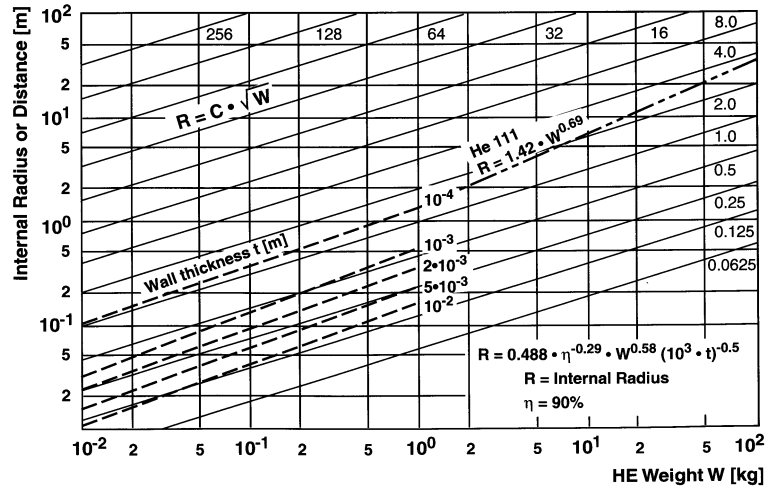

Figure 8. Distance R as a function of charge weight W for the square root law with the damage number as parameter or internal tube radius R as a function of the high explosive weight W with the steel tube wall thickness as parameter, respectively damage of the World War II airplane He111 in the same diagram.

3. Conclusion

It is surprising how many people or institutions nowadays believe in simulation models where you achieve with one calculation—which means typically some time with also a number of problems at the beginning—“one” result compared to an experiment. These people or groups are normally no more interested in the simple analytical equations where you can get very good trend analyses using small scaled tests. Extremely good extrapolations can be drawn on large tests or accidents with very big charges.

The damage of the tubes corresponds only to the dynamic load of the blast wave and not at all to any static pressure because this would require a fully closed container. But in the near field, this dynamic load is the dominant factor. A significant difference is not expected if the tube is tightly closed.

In this investigation totally unconfined bare high explosive charges are used. If fragments should be accelerated by the detonation of the high explosive charge and the container has to protect besides the blast wave also the fragments, a different or modified approach has to be taken into account.

4. References

- (1) M. Held, “Schutz- und Transportbehälter für Sprengladungen” (“Protecting and transport container for high explosive charges”), *Wehrtechnik* 7, 266–268, (1969).
- (2) M. Held, “Blast Waves in Free Air”, *Propellants, Explosives, Pyrotechnics* 8, 1–7, (1983).
- (3) M. Held, “Similarities of Shock Wave Damage in Air and in Water”, *Propellants, Explosives, Pyrotechnics* 15, 149–156, (1990).

(Received August 8, 1999; Ms 55/99)