

[54] **EXPLOSIVE APPARATUS**
 [75] Inventor: **Jerry W. Cummings**, Palos Verdes Estates, Calif.
 [73] Assignee: **North American Rockwell Corporation**, El Segundo, Calif.
 [22] Filed: **Dec. 27, 1966**
 [21] Appl. No.: **607,129**
 [52] **U.S. Cl.**102/6, 102/66, 102/90, 149/15
 [51] **Int. Cl.**.....**F42b 24/15**
 [58] **Field of Search**.....102/6, 57, 90, 66, 102/24 HZ, 56; 149/2, 19, 15

3,370,536 2/1968 Francis et al.102/66
 3,382,800 5/1968 Biggs, Jr.102/6

Primary Examiner—Samuel W. Engle
Attorney—William R. Lane, Allan Rothenberg and Richard D. Seibel

[57] **ABSTRACT**

In one embodiment a cylindrical mass of fuel is surrounded on the sides by a layer of high explosive for implosive dissemination of the fuel. Axially within the fuel is a frangible tube containing a powdered igniter mixture of metal and metal oxide which are exothermically reactive together. Gas voids are provided in the igniter mixture for assuring initiation of reaction therein. Means are provided for detonating the high explosive which sends an implosive shock wave through the fuel and the metal-metal oxide mixture. The mixture is thereby ignited and fragmented and the heated mixture and the fuel are radially disseminated providing ignition of the fuel as it is disseminated. The nature of the arrangement permits use for fuel of a broad variety of materials including materials known to be combustible and also a variety of materials not normally considered combustible.

2 Claims, 7 Drawing Figures

[56] **References Cited**

UNITED STATES PATENTS

103,477	5/1870	Link	102/66
1,287,372	12/1918	McGaw	102/66
2,445,311	7/1948	Cooke et al.	102/6 X
2,445,312	7/1948	Cooke et al.	102/6
2,535,309	12/1950	Mari	102/34.4
2,866,414	12/1958	Smith	102/24 X
2,972,948	2/1961	Kray	102/56
3,049,454	8/1962	Stark	149/2
3,198,677	8/1965	Thomas	149/19

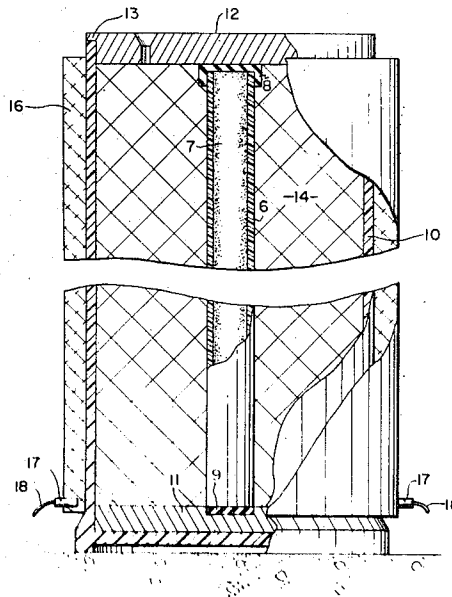

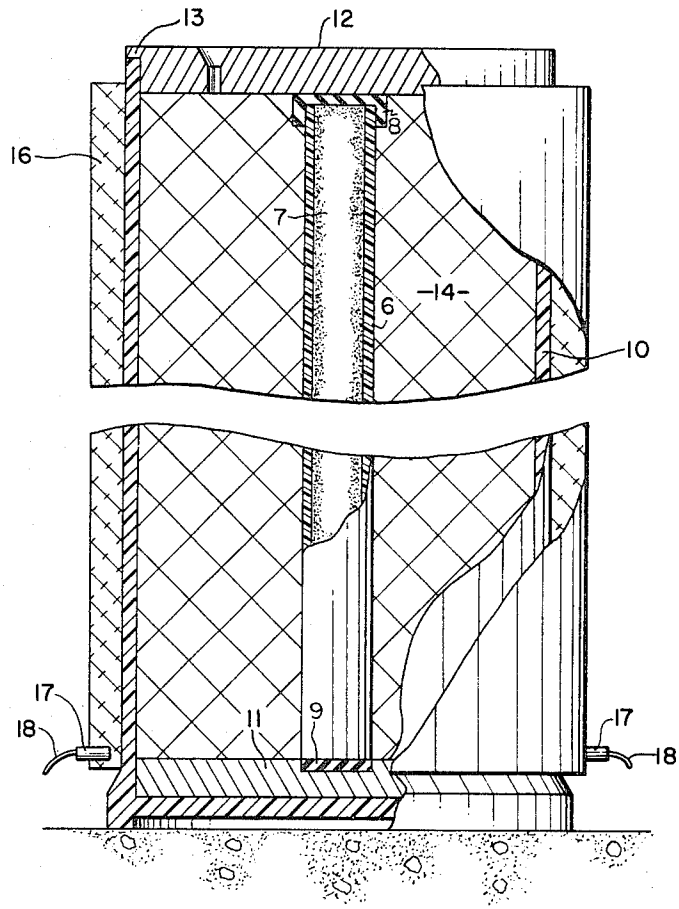

FIG. 1

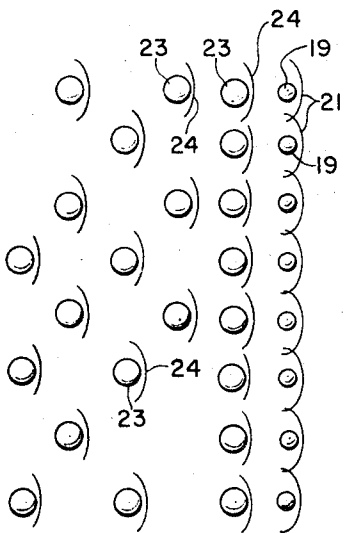

FIG. 2

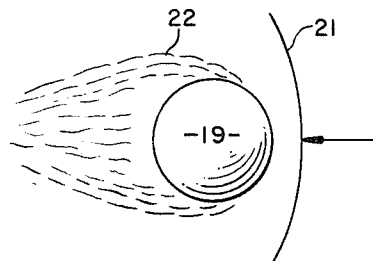

FIG. 3

INVENTOR.

JERRY W. CUMMINGS

BY

Richard D. Seibel

ATTORNEY

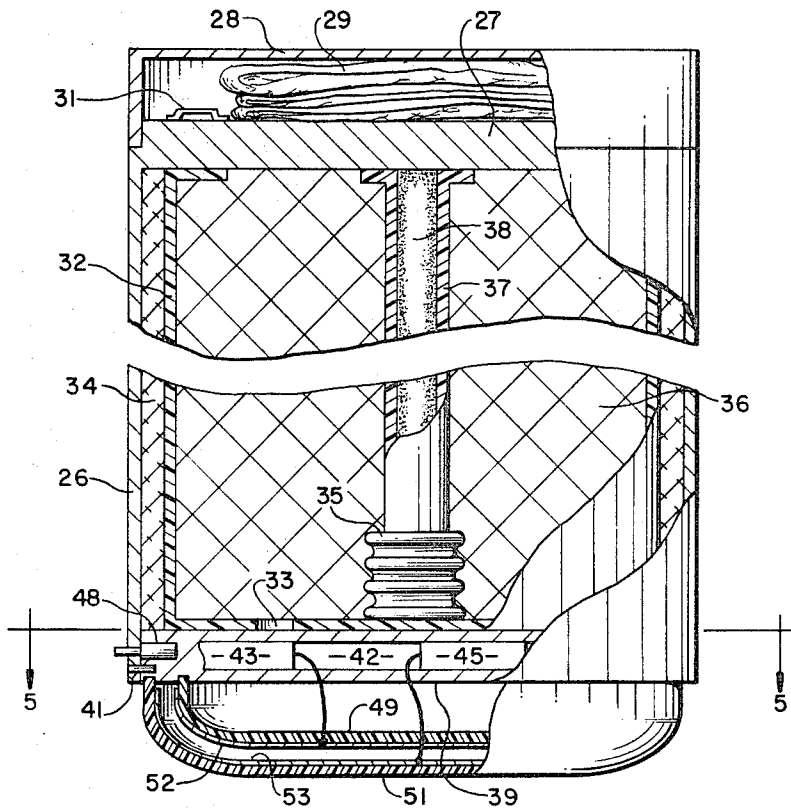

FIG. 4

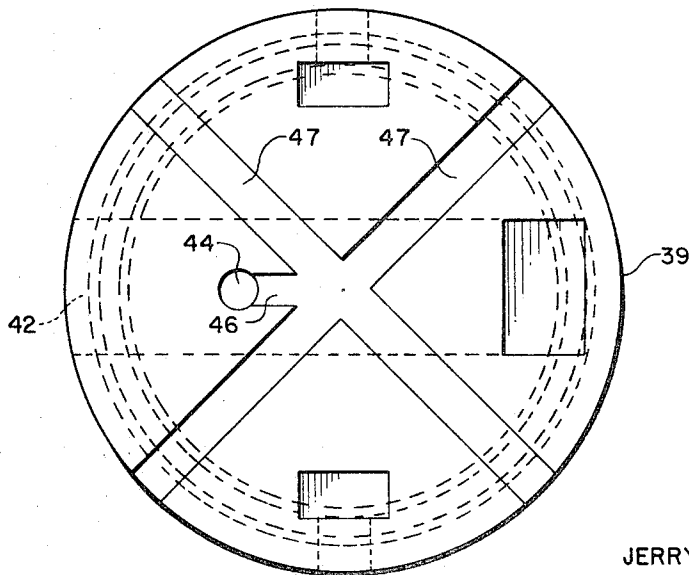

FIG. 5

INVENTOR.
JERRY W. CUMMINGS

BY

Richard D. Seibel

ATTORNEY

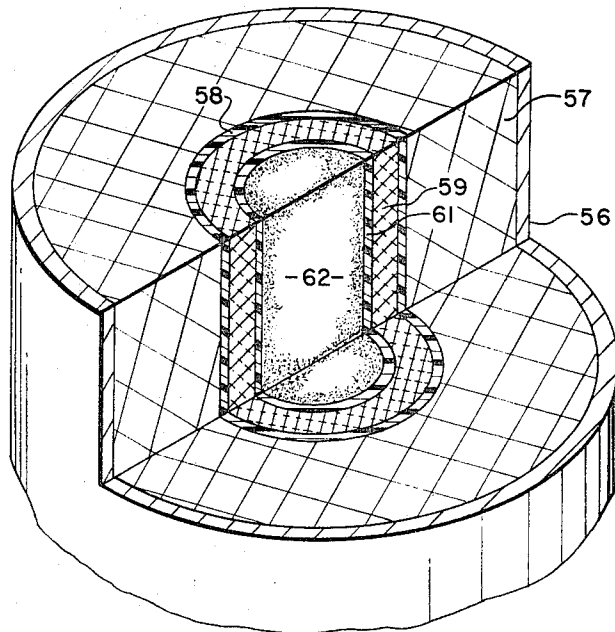

FIG. 6

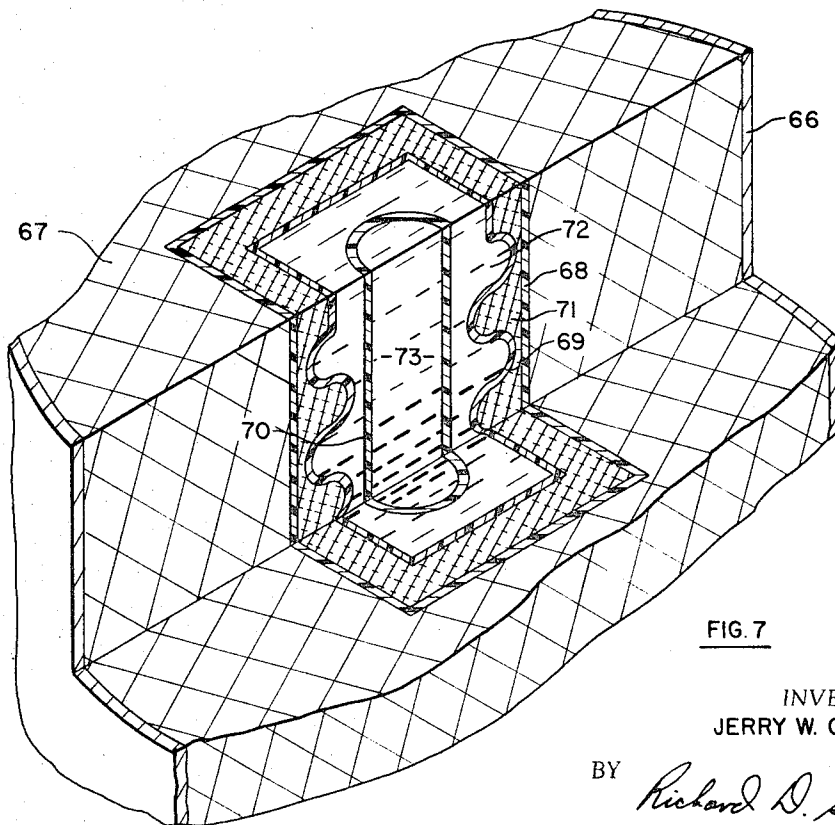

FIG. 7

INVENTOR.
JERRY W. CUMMINGS

BY *Richard D. Seibel*

ATTORNEY

EXPLOSIVE APPARATUS

BACKGROUND

Military munitions in general offer many damage mechanisms such as, for example, increased pressure or over-pressure maintained for short-time intervals, fragmentation or flight of fragments, and thermal effects, each of which will cause damage to either material or personnel depending on intensity of the effect. The first of these damage mechanisms is what is known as "blast" and is the principal mechanism of destruction when a high explosive is detonated. In many weapons a fragmentation mechanism is added wherein a frangible container or prepared shrapnel is incorporated in the weapon to provide a cloud of high velocity fragments or shrapnel for damaging material or wounding personnel. Certain other types of weapons rely principally on thermal effects such as the conventional napalm weapons wherein a jelled gasoline, benzene, or similar fuel is ignited and spared over an area it is desired to burn.

The usual military weapons outside of nuclear devices rely on one or two of these damage mechanisms with minimal presence of the other mechanism or mechanisms. Thus, for example, a high explosive device usually relies on blast effect alone or may include some minor amount of fragmentation. Similarly, the usual fragmentation weapons do not include more high explosive than is needed to propel the fragments and a minimal amount of blast effectiveness or over-pressure is noted at any substantial distance from the point of detonation. In neither of these cases is a substantial thermal effect noted. In the conventional napalm, on the other hand, the thermal effects due to burning of the napalm are predominant and very little fragmentation or blast destruction is obtained.

Another type of weapon is the so called fuel-air explosive (FAX) weapon wherein a combustible material is dispersed as a vapor or aerosol in a cloud so as to mix thoroughly with the naturally occurring air to form a detonable or burnable mixture, and the cloud is ignited. These weapons often produce both blast and thermal effects for the mechanisms of destruction. The FAX type weapon has an advantage in that the weight effectiveness is high since only fuel is delivered and the oxidizer, namely air, is virtually omnipresent. This is in contrast to explosives which do not rely on combination with air to supply energy and the energy per unit weight delivered is lower.

A substantial difficulty with the prior art fuel-air explosive (FAX) weapon is that of the timing of ignition of the cloud of combustible mixture. In order to obtain optimum effectiveness from the weapon, it is desirable to ignite the fuel-air mixture in the cloud when it is in the concentration range for detonation rather than combustion. The time for the cloud to reach the optimum concentration, however, varies with atmospheric conditions such as temperature and pressure. Since these conditions will vary the time for the fuel to be dispersed to the optimum concentration for detonation, various fusing mechanisms have been suggested for FAX weapons in order to obtain ignition of the fuel cloud at some pre-selected time after dispersion of the fuel has commenced. Such mechanisms have not been satisfactory since, for example, different time intervals are required for dispersion of a fuel cloud in low tem-

perature, low altitude and in high temperature, high altitude.

BRIEF SUMMARY OF THE INVENTION

According to a significant feature of this invention there is provided a fuel selected from a broad class of materials that are combustible with air after high energy implosive dissemination, substantially surrounded by a high explosive of determined power. According to another feature of the invention, a critical power of explosive is not required and there is provided an igniter, operable in response to detonation of explosive to disseminate high temperature fragments of fuel igniting material in a direction substantially the same as the direction a fuel is dispersed.

Thus, it is an object of this invention to provide an improved fuel-air explosive device.

Other objects and many of the attendant advantages of this invention will become apparent by examination of the following detailed description and accompanying drawings wherein:

FIG. 1 illustrates in cutaway a mine constructed according to the principles of this invention;

FIG. 2 illustrates a cloud of droplets dispersed according to the principles of this invention;

FIG. 3 illustrates one of the droplets of FIG. 2;

FIG. 4 illustrates an aerial bomb constructed according to the principles of this invention;

FIG. 5 transverse cross section of the aerial bomb of FIG. 4;

FIG. 6 illustrates in cutaway another embodiment of this invention; and

FIG. 7 is a cutaway view of another embodiment of this invention.

Throughout the drawings, like reference numerals refer to like parts.

DETAILED DESCRIPTION

FIG. 1 illustrates a mine constructed according to the principles of this invention. As provided in practice of this invention according to a preferred embodiment, there is provided a cylindrical plastic container 10 which may, for example, comprise an open-ended polyethylene cylinder about 8 7/8 inches tall and 4 3/4 inch diameter, having a wall thickness of about 0.17 inch. Inside the bottom of the plastic container 10 is a circular bottom end plate 11 which may, for example, be a one-half inch thick aluminum plate. Although pure aluminum is preferred, it will be apparent that aluminum alloys and other similar materials such as copper, malleable iron and similar ductile materials can also be employed as the bottom end plate 11. At the top of the plastic container 10 there is provided a circular top end plate 12 having a flange 13 at the periphery thereof for setting on top of the plastic container 10 and closing the upper end thereof. The top plate 12 is preferably a one-half inch aluminum plate substantially the same as the bottom end plate 11.

Inside the plastic container 10 is a fuel 14 discussed in detail hereinafter. The fuel 14 preferably comprises naphthalene or may also comprise, as discussed hereinafter, napalm, finally divided polyethylene, dioxane, aviation gasoline, jet fuel, or other hydrocarbons or red phosphorous or other materials pointed out hereinafter.

Surrounding the sides of the plastic container 10 is a substantially continuous layer of high explosive 16 about three-eighths inch thick. The layer of explosive 16 can comprise, for example, RDX (cyclotrimethylenetrinitramine) or PETN (pentaerythritol tetranitrate) in a conventional flexible binder. Such an explosive is readily available commercially from E. I. duPont de Nemours, Wilmington, Del., under the trademark Detasheet. It will be apparent to those skilled in the art that many other kinds of high explosives can also be employed for the explosive layer 16 such as tetryl, TNT, or conventional military high explosives. At the bottom of the explosive layer 16 there are provided four conventional detonators 17 equally spaced around the periphery of the cylindrical mine. An individual strand of conventional timed fuse or Primacord 18 is connected to each of the detonators 17. The four strands of Primacord 18 are in turn connected to a single detonator (not shown) which can, for example, be an electric detonator fired from a control point. The four strands of Primacord 18 are each cut to a uniform length so that each of the detonators 17 is simultaneously initiated. If desired, a weather-proof plastic or metal cover can be provided over the mine for protection, camouflage and the like as will be apparent to one skilled in the art.

In use of a mine as described and illustrated, it may be placed on a defensive perimeter, for example; and upon recognition of approach of enemy personnel, the mine can be detonated from a control point by applying an electric signal to the electric detonator (not shown) which ignites the strands of Primacord 18 which in turn initiate the detonators 17. The detonators 17 in turn initiate the explosive 16 which causes a substantially cylindrical shock wave to be propagated through the fuel 14 towards the center of the cylindrical mine. As the shock wave travels inwardly through the fuel, it is reinforced by its convergence. The high velocity shock wave ejects the fuel 14 radially outwardly, that is, in a direction normal to the shock wave and opposite to the direction of travel of the shock wave. Such a dispersion of the fuel 14 can be termed as implosion wherein the fuel is subjected to a converging shock wave from the exterior. This is contrasted to explosive dispersion wherein the fuel is dispersed by a centrally located explosive and is dispersed partly by an expanding shock wave and partly by action of expanding combustion products. The passage of a high energy shock wave through a material accelerates the material, and in an implosive device, the presence of relatively unyielding material all around any given element of material causes a net ejection of the material in an outward direction. By adapting this principle in the practice of this invention, the effectiveness of ordnance devices is vastly improved.

The front of propagation of the converging shock wave through the fuel is not completely cylindrical since the explosive is initiated at one end and the propagation velocity of detonation through the explosive is in the order of 6,000 meters per second and the shock wave velocity through the fuel may be in the order of 3,000 meters per second for liquid fuels and may be considerably smaller for other fuels, such as porous solids. This would indicate that some of the fuel will be ejected in upward and downward directions from the mine upon explosion thereof.

It is apparent, however, that most military targets, particularly for mines, involve men and materiel which are within a few feet of ground level and any of the weapon effects directed upwardly are essentially wasted. It is for this reason that the end plates 11 and 12 are provided on the mine described and illustrated in FIG. 1. The end plates are appreciably reflective to the shock waves since aluminum has a very substantial impedance mismatch with substantially any material forming the fuel and shock waves are therefore reflected therefrom. The reflected shock wave causes the shock wave traveling through the fuel to behave in a manner similar to what would be obtained if an infinite column of fuel and explosive were exploded. It is for this reason that a substantial quantity of the fuel is ejected radially from the mine and a relatively small quantity of fuel is ejected longitudinally, that is, upwardly or downwardly. The end plates, particularly the top end plate 12, also assist in ejecting fuel radially since a substantial pressure is generated in the interior of the fuel due to the surrounding explosive 16, and the inertial properties of the end plates prevent the fuel from traveling longitudinally and, instead, cause it to be dispersed radially.

According to another significant feature of the invention an igniter may be incorporated in the explosive device illustrated in FIG. 1 in order to assure that adequate ignition energy is available within the cloud of disseminating fuel at whatever time after the beginning of dissemination the cloud enters the detonable region. With this arrangement the described criticality of power level of the explosive may not be required. The igniter herein described initiates combustion substantially at the same time as the fuel is disseminated in the cloud by disseminating high temperature igniter particles together with the disseminating fuel cloud and there is no reliance on secondary sequential igniting sources. Thus, in a preferred embodiment as illustrated in FIG. 1, the igniter takes the form of a centrally located tube 6 whose symmetry axis coincides with the axis of the container 10. The tube 6 is filled with a mixture of reactive materials 7, hereinafter described, which is highly exothermic. A plastic cap 8 is provided at the upper end of the tube 6 containing the reactive mixture or, if preferred, a plug or a closed end tube can be employed. At the lower end of the tube 6, there is provided a rubber or similar plug 9 embedded in a shallow recess in the bottom plate 11. The rubber plug 9 provides a loose closure of the tube 6 to prevent mixing of the fuel 14 with the reactive mixture 7. In the case of liquid fuels, the tube 6 can be sealed by the end covers 8 and 9, respectively. It is preferred that the tube 6 be constructed of a frangible material, such as Micarta, or other brittle plastic, or glass or the like can be employed.

As hereinabove mentioned, one of the problems with prior art FAX type weapons is the timing of ignition in order to assure detonation in the disseminated cloud of fuel vapor. It is also significant that the means for initiating detonation in the cloud of disseminated fuel be contained within the cloud at the time it is desired to initiate detonation. Thus, if a sequential detonator is employed, it may be ejected from the cloud prior to the time at which detonation is desired and be quite ineffective. The igniter provided in the practice of this invention is contained within the fuel cloud for several

milliseconds after initiation of dissemination, thereby assuring detonation at whatever time a detonable composition is reached. Such a result is obtained by providing a substantial number of initiation or ignition sources within the cloud, said sources having a spectrum of velocities so that it is assured that at least some of the igniting sources are within the cloud when a detonable mixture is attained.

It is therefore a broad function of the preferred igniter to provide a source of a plurality of high velocity, high temperature particles within the fuel cloud. The general means for providing such ignition sources is the positioning of reactive materials 7 which are highly exothermic in an intimate mixture in such a position in the explosive device that a high energy shock wave is passed therethrough. In the preferred embodiment, the converging shock wave from the explosive 16 shatters the frangible tube 6 and converges through the reactive materials 7. The passage of the high energy shock wave therethrough initiates a chemical reaction between the intimately mixed reactive materials, fragments the products of the reaction, and imparts momentum to the products of the reaction so that they acquire an outward velocity within the cloud of disseminated fuel. Since the imploding shock wave is the same one as has just disseminated the fuel 14 in a dispersing cloud, the initiation of the igniter is substantially simultaneous with initiation of dissemination.

The reactive materials of the igniter are preferably contained in a frangible holder or tube in order to obtain a wide dissemination of relatively small fragments. If a malleable or otherwise resilient tube is used to contain the reactive materials a substantial portion of the products of the reaction may be trapped within a compressed or squeezed container in such a manner that the entire mass moves relatively slowly through the cloud. Thus, for example, when an aluminum tube was employed to contain the reactive mixture a large white, hot portion of the tube was seen being ejected from the fuel cloud. If it is desired to introduce an ignition source with a substantial delay time a malleable or resilient tube may be employed. By appropriately sizing or shaping the containing device or tube substantial sizes of hot mass may be emitted which have delay times within the volume of the cloud in the order of 500 milliseconds. Frangible tubes are, however, preferred for quick introduction of a high number of hot ignition particles. Glass as well as plastic materials such as hard phenolics which exhibit brittle characteristics may be employed.

The mixture of reactive materials 7 in the igniter preferably comprises a compound AB and an element C which undergo an exothermic reaction of the type $AB + C = AC + B$. In particular, these reactions are typified by the Goldschmidt reaction wherein a stable metal oxide is mixed with a metal. In this type of reaction, the second metal replaces the metal in the compound with the liberation of considerable heat which elevates the reaction products of metal oxide and metal to an elevated temperature. A familiar example of this type of reaction is the so called Thermit reaction in which finely divided iron oxide and aluminum are caused to react to produce high temperature aluminum oxide and molten iron. In order to be useful in an igniter, the quantity of heat generated by the reaction

must be sufficient to elevate the reaction product to a temperature substantially in excess of the temperature required to cause ignition of the fuel-air mixture.

When aluminum is the element C in the reaction of AB and C, the metal oxide, in which B is the metal and A is oxygen, may comprise one or more of the oxides of copper, cobalt, nickel, chromium, manganese, zinc, and the like as well as iron. When the element C is magnesium, zirconium oxide can also be employed and, as will be apparent, when the metal C is sodium, potassium barium, calcium, or similar highly active material, many other metal oxides AB can be employed.

By the choice of metals B and C, in the reactive chemical mixture, metallic particles of B and compound AC provide for variations in the velocity with which such particles are emitted. A choice of high density material in the product of reaction results in the arrival of the fragments of reaction product at any given radius in the fuel cloud later than fragments of a low density material. Thus, for example, relatively light weight fragments of aluminum arrive at a given radius sooner than heavier density particles of copper. Thus the choice for a selected explosive thickness and geometry permits an adjustment of the time at which hot metal and metal compound fragments arrive at a substantial distance from the point of origin. Inherent in this selection of materials is the ability to control the time at which ignition sources are presented to some substantially large fraction of cloud mass.

The hot, metallic fragments are preferably selected so as to preclude chain stopping. Certain elements are known to have an affinity for organic radicals such as, for example, sodium. The sodium may react directly with organic radicals and limit combustion thereof with air and hence lower the yield of a FAX type weapon. Thus, the free metal produced in the ignition source should avoid a type which energetically engages in reactions with organic radicals typical of chain stopping. Among the materials satisfactory from this standpoint, cobalt, nickel, zinc, chromium, copper, iron and manganese, are examples. The selection of materials not acting as chain stoppers can be of significance since a substantial portion of the free metal after the reactive yield may be at sufficiently elevated temperatures to be in the vapor form and as such, reactivity with organic radicals is particularly high.

Preferred materials to employ in the igniter comprise an intimate mixture of copper oxide and aluminum or an intimate mixture of magnesium and zirconium oxide all in a size range of about 100 microns. Copper oxide and aluminum is a desirable mixture since the reaction products, aluminum oxide and molten copper, have favorable temperatures and densities after reaction and provide a good spectrum of particle velocities. The magnesium and zirconium oxide mixture is also preferred since one of the reaction products is hot metallic zirconium which additionally reacts with the nitrogen, oxygen, and water vapor in air in order to produce additional thermal yield. In addition to the metal oxides, it will be apparent to one skilled in the art that combinations of metal and metal halide, such as sodium and aluminum chloride or magnesium and copper chloride, can also be employed. Similarly, ammonia compounds, sulfides, nitrides, borides, carbides, hydrides, phosphides, peroxides and the like can be

employed in the practice of this invention so long as the free metal is substantially more electropositive relative to the anion than is the metal originally compounded therewith. Thus, for example, a mixture of barium peroxide and magnesium provides a highly exothermic reaction that is relatively easily initiated. Calcium carbide is an inexpensive and useful material.

In general it is preferred to employ a stoichiometric mixture of the reactive materials so that a maximum temperature is obtained. It may be desirable in some instances to introduce a substantially inert material in the igniter mixture so that more massive fragments are ejected at a somewhat lower temperature. This effect may be obtained, for example, by incorporating an excess of one of the reactants in the mixture. If excess aluminum is mixed with a metal oxide, molten aluminum is produced and ejected. The presence of inert materials may also slow the reaction and make the fragments of igniter material persist at elevated temperature for a longer time. In order to initiate reaction of the reactive mixture 7, it is preferred that the materials have controlled voids therein. Thus, they may be in the form of fine powders or similar arrangements so that a substantial amount of gas filled void space is provided in the mixture. The gas filled voids act in substantially the same manner as the gas filled voids hereinafter described in relation to powdered fuels. Broadly the gas is heated to an elevated temperature by passage of the shock wave therethrough and the hot gas, in turn, heats the reactive materials. Goldschmidt type reactions employing metals and metal oxides are relatively slow to start and propagate under usual conditions since there is a substantial requirement for sensible heat for elevating the temperature of the reactants to a point where the reaction can commence. Such a difficulty was noted, for example, in Thermit type incendiary bombs wherein it was required to initiate the reaction in the Thermit upon impact of the bomb and after an appreciable time to permit thorough reaction, explode a center burster for scattering the burning Thermit mixture. By employing a substantial amount of gas filled void spaced within the reactive mixture in the practice of this invention and providing means for passing a high energy shock wave through the gas filled voids, there is provided a means for elevating the temperature of the entire reactive mixture to a temperature at which the reaction can commence. There is, then, substantially no time lag between initiation of the reaction and propagation thereof throughout the entire reactive mixture.

It is found with fine, dense powders, such as a metal and metal oxide, that there is relatively dense packing and a relatively small amount of gas filled void space is left between the individual particles. This is, in part, also due to the spectrum of particle sizes occurring in these powders which contributes to dense packing. It is therefore preferred that a controlled proportion of extra void spaces be specially provided in the reactive mixture for promoting the initiation of reaction thereof; that is, voids that are in addition to the small gas filled voids between particles of the mixed powders. Reaction can be initiated by addition to the reactive mixture of controlled voids in the form of small, hollow particles such as the so called microspheres which comprise hollow spheres of plastic such as phenolic resin or

the like. Similarly, controlled gas voids can be provided by plastic foams, glass foams or other materials having a substantial gas volume therein. It is preferred that the controlled void space within the reactive mixture be in the range of about from 5 to 35 percent of the volume of reactive mixture; in addition to the inherent void space between the particles of powder, and it is also preferred that the gas filled extra voids be in the size range of from about one one-hundredth to one-fourth inch in order to assist in fragmentation of the reactive mass. In order to provide ignition sources throughout the expanding cloud of fuel in a preferred embodiment, it is desirable to fragment the reactive mixture into substantial particles or clusters of powder grains which are at elevated temperature during their transition through the cloud of fuel. This assures a distribution of ignition sources within the cloud, both in space and in time, so that an ignition source is assuredly available at the time the cloud reaches a detonable mixture.

Thus, for example, a suitable igniter employs a mixture of copper oxide and aluminum or magnesium oxide and zirconium with about 10 to 20 percent of additional void space provided in the form of organic foam. Typical foam particles are in the order of about 3/16 inch diameter and may comprise, for example, bits of Styrofoam (polystyrene foam), epoxy bubbles, polyethylene foam, or heat expanded rice granules (Puffed Rice) which are uniformly mixed within the mixture of reactive powders. When such particles of foam are distributed approximately uniformly in the reactive powders, the particles are on approximately 1/2 inch centers and since fragmentation of the mixture generally occurs through the foam, fragments of reactive mixture having sizes in the range of from one-fourth to one-half inch are produced. It should be recognized that when fragments of the mixture are provided, these comprise large clusters of the reactive powders, possibly sintered together by the extreme temperatures and pressures of the shock wave, along with reacting materials and the products of the reaction which are heated to an elevated temperature. Similarly pressed pellets of reactive mixture can be employed with the inherent large void space therebetween. This also permits good control of fragment size. It is found that upon ejection of such fragments from an igniter as provided in the practice of this invention, the particles are at an intense white heat.

Thus, controlled void spaces filled with gas are provided within the mixture of reactive powders for providing "hot spots" within the mixture of reactive powders, and these hot spots provide sources of ignition for the reactive mixture in case reaction does not commence within the main bulk of the reactive mixture due to dense packing of the powders. The controlled voids also serve to promote fragmentation of the reactive materials in a controlled manner for providing a selected particle size. Fragmentation in a controlled manner and ignition hot spots can also be obtained by using hollow, frangible tubes or the like within the reactive mixture in lieu of the foam particles hereinabove described.

The fragments of reacting mixture, preferably in the size range of from about one-fourth to one-half inch, are ejected from the igniter so as to pass through the expanding cloud of fuel at high velocity. Since there is a

spectrum of fragment sizes of reacting mixture which are acted upon by the converging shock wave, these fragments have a spectrum of velocities. Generally speaking, smaller size fragments have higher velocity than larger size fragments of similar material and fragments nearer the center of the converging shock wave may have somewhat higher velocity than fragments further out in the igniter. It has been found that hot fragments from the igniter are ejected from the surface of an expanding cloud of fuel of the size provided by a mine as described and illustrated in FIG. 1, throughout the time interval from 10 to 50 milliseconds after initiation of dissemination of the cloud. Thus, it is assured that the distribution of hot fragments in time and hence in the space of the cloud assures the presence of a plurality of ignition sources within the cloud at whatever time the cloud of expanding fuel enters the detonable region.

The fragments of igniter mixture apparently have a lower initial velocity than the fuel forming the disseminating cloud due to the heavier fragments which must be accelerated. However, because the fragments of igniter mixture are heavy they tend to remain at high velocity longer than the light droplets and vapor of the fuel. Thus, although the fragments are initially slower, the fuel is slowed by drag and the fragments eventually emerge from the cloud. In practice, a number of white hot "sparklers" are seen emerging from the cloud of fuel about 10-15 milliseconds after initiation. The emergence of new sparklers continues for at least an additional 40-80 milliseconds thereafter. The continued presence of hot fragments in the cloud assures detonation thereof when a detonable mixture is reached.

The advantages of imploding the reactive mixture as compared with an explosion thereof by means of a center burster of explosive are impressive. Thus, in the implosion of an igniter as provided in the practice of this invention, the entire reactive mixture is heated to an elevated temperature due to passage of a high energy shock wave through gas filled voids amongst the particles thereof. In addition, the implosion compresses and possibly coalesces the mixture of powders. In addition, when controlled void spaces, as provided by foam particles or the like, are present, hot spots are generated in the igniter for deliberately initiating the reaction at specific locations within the mixture. The imploding shock wave also fragments the mixture of reactive powders at the void locations so that the fragment size of reacting material is controlled. These particles are finally ejected at a spectrum of high velocities to provide ignition sources within an expanding cloud of fuel.

Explosive type of dissemination of a reactive mixture, on the other hand, may heat a small amount of the mixture to an elevated temperature sufficient to initiate reaction. No substantial amount of heating is obtained, however, by the shock wave alone as evidenced by the relatively poor performance of Thermit type incendiary weapons employing a center burster. In addition, an explosive dissemination of the reactive mixture tends to separate the individual particles of reactive mixture so that no reaction therebetween can occur. Even if the individual pieces of powder are not disseminated, the fragment size of the mixture is relatively small when ex-

plosive dissemination is employed and few of the fragments may be undergoing reaction.

The reason for the lack of heating of the reactive mixture and the small fragment size may lie in the relatively short time that an expanding shock wave acts on the reactive mixture as compared with the relatively longer dwell time of the reactive mixture within the influence of an imploding shock wave. With an exploding or expanding shock wave, the material is ejected at substantially the same time it is undergoing heating to initiate reaction, whereas in the imploding shock wave situation as provided in the practice of this invention, the shock wave first acts to heat the reactive mixture and a very short time thereafter causes ejection thereof. This dwell time, even though short, gives sufficient time for heating of the reactive mixture and the initiation of reaction thereof. The strength or energy of the shock wave in the implosion is continually increasing due to convergence thereof, thereby giving high heating rates. The explosion shock wave, on the other hand, is diverging and losing energy per unit area as the square of the distance from the point of initiation, and therefore the energy available to impart to the reactive mixture is continually decreasing.

The fuel contained in the mine of FIG. 1 or an aerial bomb or similar explosive device of similar construction can be in one or more of two classes of material. The first class comprises materials normally subject to explosive reaction or detonation when mixed with air and ignited. Typical materials in this class include conventional aviation gasoline, pentane, hexane, octane, benzene, and similar materials forming explosive compositions when mixed with air. It is preferred that the heat of combustion of such materials be greater than about 750,000 BTU per cubic foot of fuel. When the energy available from combustion of the fuel is in this order of magnitude or greater, a reasonable effect can be obtained from an explosive device having a useful volume. It is found that the measure of heat of combustion in terms of the volume of fuel available is a more useful measure than the heat of combustion per unit weight since the limiting factor in many military ordnance devices is volume rather than weight. Gasoline is a particularly desirable fuel since the explosive devices can be loaded in the field rather than requiring preloading.

A second class of fuel materials comprises compounds not normally detonable, having relatively longer chains or larger numbers or rings that are broken into relatively shorter chains or smaller molecules which form detonable mixtures with air after being subjected to the pressures and temperatures associated with the high energy shock waves provided in the practice of this invention. An example of such material is acetaldehyde which is apparently decomposed upon passage of a shock wave therethrough into molecules of methane and carbon monoxide and possibly other molecular fragments which are highly explosive when disseminated in air. Another highly useful material in this class is, for example, solid naphthalene which has a heat combustion of about 1,200,000 BTU per cubic foot, but which is not readily detonable in air. Upon passage of a shock wave through naphthalene, the relatively larger molecules are apparently broken into many smaller molecular frag-

ments of the decomposed ring structure, and probably free radicals which are extremely reactive due to the deficiency of hydrogen. As a matter of fact, one of the highest yields obtained in FAX-type ordnance devices constructed according to the principles of this invention is obtained with naphthalene as the fuel and with a layer of explosive around the naphthalene greater than about one-fourth inch. The advantages of a solid fuel as compared with a liquid in an ordnance device are apparent.

Another particularly valuable fuel for use in such a device comprises polyethylene which upon passage of a high energy shock wave therethrough under suitable conditions, is broken into shorter chain lengths comprising ethylene and short chains of polyethylene, all of which have broken chain ends which are highly reactive. Polyethylene is a particularly desirable fuel material because of its substantial inertness for handling before explosive decomposition thereof, and because of the high energy available. It is found that polyethylene gives effects substantially as good as naphthalene.

Decomposition of longer chains into shorter chains upon application of shock wave energy is a completely reasonable phenomenon. Thus, it would appear to fit within a class of decompositions of very complex molecules already known. Thus, for example, complex molecules can be broken or decomposed by the application of ultraviolet radiation. Application of a very small pulse of energy in an extremely short period of time as represented by a photon of ultraviolet applied at the speed of light is known to break complex molecules. Similarly, statistical application of energy to complex molecules over relatively longer periods of time is provided in conventional petroleum cracking, wherein long and complex molecules are subjected to elevated temperature and pressure and undergo cracking. It would appear that the application of high energy by means of a shock wave fits somewhere in between decomposition by photons and thermal cracking. The decomposition of molecules therefore includes ultraviolet decomposition wherein a small energy is added within an extremely short period of time, a shock wave wherein a much larger pulse of energy is added in a somewhat longer period of time, and thermal cracking wherein a substantial energy is added over a very long period of time.

An explosive shock wave generated by high explosives can be represented as a wave of pressure as a function of time at a given arbitrary location within a material through which the shock wave passes. It is the nature of a shock wave that at the given location the pressure virtually instantaneously rises to a high peak and thereafter exponentially decays to approximately the original pressure in a total elapsed time measured in microseconds. In general, the peak pressure generated is independent of the thickness of explosive employed, however, the shape of the decay curve following the peak is a function of the thickness of high explosive generating the shock wave. As the thickness of the explosive increases the time that the pressure remains near the peak is prolonged, and the time to which an element of material through which a shock wave passes is subjected to the highly energetic conditions of the shock wave is also prolonged.

Thus, it has been found that by increasing the thickness of high explosive surrounding a fuel above about one-quarter inch the fuel is subjected to elevated pressure for a sufficient time that thermal decomposition of organic molecules may occur. Although for purposes of discussion the shock wave can be considered as a pressure peak this is merely a manifestation of the energetic conditions in the shock wave which include high temperatures and rapid viscous shearing of the matter through which the shock wave is passing. In addition to the increased time interval for transit of the shock wave due to the thickness of explosive there is also an increased time interval in an implosive arrangement due to the transit of the shock wave into the fuel from the surrounding explosive and return of the shock wave back out again after reaching the center, which at least effectively doubles the time of exposure to the elevated pressure and other energetic conditions.

In the usual arrangement the increase in thickness of high explosive does not increase the peak pressure obtained by a shock wave but only influences the decay of pressure after the passing of the peak. The peak height is determined only by the nature of the explosive employed. In an imploding shock wave situation, however, the peak pressure increases due to convergence of the shock wave as the wave travels inwardly. As the peak pressure increases due to convergence of the shock wave the velocity at which the leading edge of the shock wave travels also increases. The pressure pulse behind the shock front does not increase in velocity in the same manner as the leading edge of the shock wave and this further contributes to the time an element of matter through which the shock wave is passing is subjected to the energetic conditions of the shock wave in an imploding situation.

If mathematical wave equations are applied to the situation of a shock wave converging through a material several possible mathematical solutions for the transit time of the shock front through a fuel to the center and back out again are obtained. In one of these mathematical solutions the transit time from the exterior of the fuel to the center and back out again is substantially independent of the radius of the fuel within the explosive when the explosive thickness is in excess of about one-quarter inch of high explosive. Although it is not certain that this mathematical solution is applicable to the imploding situation, it is certainly plausible. Evidence that it may be applicable is found in the fact that substantially similar effects are noted when the explosive thickness is in excess of about one-quarter inch when the diameter of the FAX type weapon is about $4 \frac{3}{4}$ inches and when the FAX type weapon is as large as 15 inches in diameter.

Other evidence of the criticality of an explosive thickness in order of about one-fourth inch is from an examination of the cloud diameter at a selected time after detonation of the explosive. Thus, if the cloud diameter at 5 milliseconds after initiation of the explosive is examined, it is found that there is a regular increase in cloud diameter with increase in explosive thickness up to about one-fourth inch; however, above about $\frac{1}{4}$ inch up to about $\frac{3}{8}$ inch explosive thickness, an increase in cloud diameter of only about 5 percent is noted. Since at least 50 percent additional energy is available due to the increased explosive thickness, and

there is no appreciable increase in cloud diameter, it is reasonable to assume that the excess energy is expended in decomposition of complex organic molecules in the fuel.

Although the critical limit of explosive thickness has been determined to be about one-fourth inch it is particularly preferred that the explosive surrounding a stable fuel in an imploding FAX type weapon be in the order of about three-eighths inch so that a substantial margin of surplus explosive is present to assure the presence of the effect under all conceivable conditions in which the explosive device might be employed.

It is found that the mere passage of shock waves through massive pieces of polyethylene and similar solid materials may not be sufficient to initiate the chemical changes hereinabove indicated. The breaking of the complex chemical molecule into simpler substances is an effect which may be obtained by proper combination of elevated temperature and elevated pressure. In order to obtain extreme elevated temperatures in many solids, it is preferable to provide the solids as porous materials having controlled void spaces therein and having air or other gas in the voids. The passage of the shock wave through the gas in the voids raises the gas to an elevated temperature which persists after passage of the shock wave therethrough.

If it is considered that a small element or particle of the solid fuel is substantially completely surrounded by a film of gas, the shock wave passing therethrough heats the gas to an elevated temperature and presents a boundary condition on the fuel particles which is essentially a step function wherein the particle is suddenly exposed to temperatures of 2,000°F or more depending on the wave velocity, gas viscosity, and similar factors. As is well known, any solid material has some thermal lag when subjected to an elevated temperature environment, that is, there is a certain time interval for a pulse of heat to pass from the outside to the center of the particle of solid fuel as the temperature suddenly increases at the boundary. The time interval is inversely proportional to the radius of the particle, squared. Thus, as the particle size or the distance separating adjacent gas films becomes increasingly smaller, the thermal lag or time constant for the thermal pulse to reach the center of the solid material becomes very short. Thus, a small particle is rapidly heated to the temperature of the gas within the boundary between the particles. When the individual particles of solid fuel are extremely small, any chemical changes due to thermal and pressure effects occur rapidly since the necessary temperature elevation is substantially concurrent with passage by the shock wave or generation of high pressure, and very rapid thermal decomposition of complex molecules can occur. When massive solids or large particles are used, the temperature pulse may lag the pressure pulse within the solid and conditions may not be proper for decomposition of relatively stable molecules such as polyethylene.

In the instance of solid fuel materials, a suitable arrangement comprises fine powders, or a foam structure of coalesced material can be employed. If desired, the fine particles which are preferably spherical powders can be sintered in order to provide a substantially solid mass of material. In any event a porous solid is preferred wherein the thermal lag between the bounda-

ry of the gas and the center of the particle is relatively low. It is apparent that solid non-porous masses of some materials, such as naphthalene, which are decomposed by transition of the shock wave therethrough can be employed. It should also be noted that sintered pellets of powders can be employed in substantially the same manner as hereinabove described in relation to the igniter.

Typical examples of materials decomposable into detonable molecules or molecular fragments include: propane, butane, pentane, hexane, heptane, octane, nonane, decane, undecane, dodecane, ethylene oxide, polyethylene, propylene oxide, polypropylene, polystyrene, styrene, butene, butadiene, isobutylene, pentene, hexene, heptene, octene, ethylacetylene, acetylene, dimethyl-acetylene, pentine, methyl butine, hexine, benzene, toluene, naphthene, ethyl benzene, propyl benzene, butyl benzene, xylene, mesitylene, mesityl oxide, cumene, pseudocumene, indine, naphthalene, methyl naphthalene, diphenyl, acenaphthalene, fluorene, phenanthrene, anthracene, fluoranthene, pyrene, benzpyrene, chrysene, naphthacene, pyridine, picoline, quinoline, quinaldine, indole, acridine, carbozole, allylbenzene, stilbene, diphenylmethane, triphenylmethane, tetraphenylmethane, terphenyl, camphor, methyl alcohol, ethyl alcohol, propyl alcohol, butyl alcohol, amyl alcohol, hexyl alcohol, phenol, benzyl alcohol, diethyl ether, methyl ethyl ether, dipropyl ether, diphenyl ether, methyl phenyl ether, dioxane, methyl butyl ether, ethyl butyl ether, dibutyl ether, diamyl ether, dihexyl ether, divinyl ether, tetrahydrofuran, acetaldehyde, benzaldehyde, propionaldehyde, butyraldehyde, valeraldehyde, acrolein, crotonaldehyde, benzaldehyde, furfural, acetone, methyl ethyl ketone, methyl propyl ketone, diethyl ketone, hexanone, methyl butyl ketone, dipropyl ketone, dibutyl ketone, diamyl ketone, chloracetone, methyl amine, dimethyl amine, trimethyl amine, ethylamine, diethylamine, triethylamine, propylamine, dipropylamine, tripropylamine, butylamine, amylamine, hexylamine, ethylene diamine, trimethylene diamine, allylamine, aniline, acetamide, propionamide, bensamide, nicotinonitrite, flour, glucose, fructose, sucrose, lactose, maltose, cellulose (such as, for example, cotton, sawdust, straw, paper), dioxane, butyric acid, isovaleric acid, caproic acid, caprylic acid, capric acid, lauric acid, myristic acid, palmitic acid, stearic acid; paraffin, charcoal, coconut oil, palm oil, olive oil, castor oil, peanut oil, corn oil, rape oil, beef tallow, lard, whale blubber, cottonseed oil, soybean oil, tung oil, linseed oil, gasoline, kerosene, jet engine fuel, bunker oil, gas oil, lubricating oil, petroleum ether, mineral spirits, heavy ends from petroleum refining, asphalt, waxes, lacquer, napalm, furan, ethyl nitrate, furfural, ethyl cellulose, nitromethane, nitrobenzene, dinitrobenzene, nitroethane, nitropropane, nitrobutane, nitropentane, light oil, carbolic oil, creosote oil, anthracene (or green) oil, pitch, fusel oil, starch, polyvinyl chloride, polyvinyl alcohol, epoxy polymers, mercaptans, and glycol, including cyclic and branched chains, polymers, and saturated and unsaturated isomers thereof, nitrate, ammonia, sulfhydryde, and cyanide substitutions thereon and heterocyclic chains with nitrogen, oxygen, phosphorus, and sulfur.

It has been found that in addition to the hydrocarbon fuels hereinabove described that red phosphorus, boron, and calcium make excellent fuel materials when employed in an implosive type ordnance device. Red phosphorus is particularly advantageous since it is normally a stable material difficult to ignite and normally of little use in military munitions. Phosphorus, however, can be allotropically transformed into what is known as white phosphorus which provides an effective military munition since white phosphorus reacts rapidly and exothermically with air. White phosphorus munitions are well known and widely used but may be difficult to handle because of the high reactivity of white phosphorus with air. It is found that red phosphorus when subjected to high dynamic pressure as obtains in the implosive type device herein described and illustrated, converts to white phosphorus. After release from the transient high pressure environment in the implosion, the white phosphorus produced tends to convert back to the red form, however, the vigorous ejection by implosive dissemination permits the white phosphorus to react with air prior to the completion of the transition back to the red phosphorous state. The incendiary and obscuration effects of white phosphorus are thereby obtained with implosive dissemination when normally stable red phosphorus is employed as the fuel.

In order to obtain a maximum effectiveness of the cloud of fuel prior to ignition thereof in the prior art FAX weapon, the fuel is disseminated to substantially the optimum cloud size and detonation is then initiated in the fuel.

When a combustible fuel is mixed with air, there is a certain range of concentration of dispersed fuel in the air that is combustible. This concentration can be expressed, for example, as the ratio of the weight of air to the weight of fuel dispersed therein. For a typical hydrocarbon such as gasoline, for example, the ratio may run from slightly above 0 to about 25 parts by weight of air per part of fuel by weight and combustion may occur throughout that region. Encompassed within the region of combustion for a typical hydrocarbon, there is often a so-called detonation region or ratio which for a typical hydrocarbon, such as gasoline, may run from a ratio of about 10 to about 16 parts by weight of air per part by weight of fuel.

When the concentration of fuel dispersed in air is outside of the combustible region, no burning occurs and a stable flame is not maintained. When the concentration is within the combustion region, the fuel chemically combines with air with the liberation of energy. The rate of propagation of a flame through the mixture is subsonic in the combustion region, and the flame is accompanied by chemical intermediates, combustion products, and the like that cause the reactions which are typically combustion to occur. In the detonation region, the rate of propagation of the reaction through the mixture is supersonic, that is, higher than the acoustic velocity in the explosive material. This creates a shock wave characterized by a steep pressure rise with accompanying temperature rise followed by a fall in pressure. The sharp increase in pressure and temperature at the shock wave causes the chemical reaction to proceed, thereby adding energy to sustain and augment the shock wave.

The usual high-explosive source of over-pressure in conventional explosive devices is essentially a point source (or relatively small volume) of a detonation which causes a shock wave to propagate radially outward. The traveling shock wave is slowed down in passing through the air because of various losses such as conductivity, viscosity of the air, and the like. After the shock wave has passed a sufficient distance from its starting point, its propagation velocity is subsonic, and at this point there is no longer any over-pressure. It is apparent that increasing the weight of high explosive causes initially higher over-pressure to be generated. However, at a short distance from the explosive the influence of increased weight is realizable only by the cube root of the increased weight. Thus, to generate very high over-pressure at any substantial distance from a detonation, very large weights of high explosive must be used.

The fuel-air explosive (FAX) weapon, however, differs substantially. In the FAX weapon a quantity of fuel is distributed through the air so that the mixture of fuel and air is detonable in a large volume or cloud. When a detonation is started in such a cloud, it travels at substantially undiminished propagation velocity throughout the extent of the cloud. In this manner, large over-pressures may be generated at substantial distances from the point of initiation of the dissemination rather than propagated to substantial distances. Although the maximum over-pressure values at the center of the detonation are not as large as the maximum value to be expected from a high explosive, large levels of over-pressure may be generated over substantial areas, and damage caused over a larger area than possible with the same weight of high explosive.

There is a limit to the volume of such a detonable cloud which is determined by the weight of fuel which is dispersed and the detonable limits of weights of air to weight of fuel. The detonable limits are principally determined by the chemical composition of the fuel being dispersed.

Thus, for example, when gasoline is employed as the fuel the detonable limit lies between about 10 and 16 parts of air to 1 part of gasoline by weight. Assuming that the gasoline is uniformly mixed as a vapor with the air and assuming the specific weight of air as 0.08 pounds per cubic foot, the range of a cloud size which would be detonable can be calculated. Thus, the ratio of the weight of air over the weight of fuel (W_a/W_f) is between 10 and 16 and

$$W_a/W_f = (D^2/4) \cdot H \cdot 0.08/W_f$$

where D is the diameter of the cloud and H is the height of the cloud. If it is assumed that the cloud has a height of about 4 feet and 3 pounds of gasoline are employed, it is found that the diameter of the cloud is between 10.7 and 13.8 feet for a detonable mixture. Thus, a cloud between about 5- and 7-foot radius would be detonable and outside those limits; namely, for larger or smaller diameters the cloud would burn or if too lean or too rich a mixture is obtained in larger or smaller clouds, nothing in the way of a noticeable reaction could be made to occur. It is apparent that if the process of dispersing a fuel produces a content of dust or droplets of fuel in addition to vapor, the diameter of the detonable cloud will decrease from the above-mentioned values.

In prior art FAX-type devices, the cloud is dispersed with particular care being taken to prevent burning of the fuel during dispersion and secondary detonators are fired at a carefully selected time interval after the beginning of dispersion when the cloud is at the optimal diameter for detonation; that is, the cloud is at a proper air-to-fuel mixture ratio within the detonable limits. The secondary detonator approach in prior art FAX weapons is difficult to put into practice because the growth rate of the cloud, as well as the detonable limits of the composition, are dependent on the ambient temperature of the munition as well as the atmospheric pressure and temperature at the point of detonation. The extremes of temperature of the fuel between polar and tropical use and the extremes of pressure between high and low altitude air are apparent. In order to obtain optimal results, therefore, it is desirable to have a variable timing arrangement which, for practical considerations, is difficult in application.

The objection usually presented to cloud burning prior to detonation involves the loss by burning of a portion of the fuel at the expense of the total energy available for detonation yield which is preferred. It is found with an explosive device constructed according to the principles of this invention that the fraction of fuel loss by burning is, at a maximum, only about 11 percent. The amount of fuel burned can be calculated from the equation

$$\frac{W_t(\text{burned})}{W_t} = 2 \left[\frac{V_c \left(\frac{W_a}{W_t} \right)_{dr} - 1}{V_g \left(\frac{W_a}{W_t} \right)_{cr}} \right]$$

where V_c is the combustion velocity, V_g is the cloud growth velocity, the subscript cr is for combustion rich and the subscript dr is for detonation rich; that is, the ratio of the weight of air to the weight of fuel is too rich for combustion or detonation, respectively.

In an explosive device constructed according to the principles of this invention, the velocity of cloud growth V_g is made very large by the use of a layer of high explosive surrounding the fuel. The explosive causes a converging high energy shock wave to pass through the fuel thereby dispersing the fuel at very high velocity. This assures a rapid rate of cloud growth which is relatively independent of uncontrolled variables such as temperature and pressure. It is preferred to employ an explosive thickness in excess of about one-fourth inch and of about three-eighths inch for an explosive device in the size range of from about 4 to 15 inches in diameter; below this thickness the velocity of cloud growth is lower and greater amounts of the fuel are burned prior to detonation.

Thus, for example, the combustion velocity for a gasoline-air mixture is in the order of less than 1,000 feet per second. The detonation velocity of such a mixture is in the order of 5,000 feet per second, and in an ordnance device constructed according to the principles of this invention the initial velocity of dissemination of fuel is in the order of 12,000 feet per second, about an order of magnitude higher than the combustion velocity. In the prior FAX type devices the velocity of cloud growth is in the order of 1,000 feet per second or less, that is, about the same velocity as the dissemination velocity slows down as the material disseminates.

In an explosive device constructed according to the principles of this invention, however, due to augmentation by burning fuel adjacent to the shock front, the high velocity shock wave does not slow down below the detonation velocity until most of the fuel has been expended by reaction in a detonation mixture region rather than by combustion. Optimum over-pressure yield over a large area is therefore obtained from such an explosive device with minimal loss of energy due to unwanted combustion. It is found that reduction in high explosive thickness below about one-fourth inch for a device about 5 inches diameter causes some reduction in the over-pressure yield and also in the thermal effects obtained from the ordnance device.

The thermal effects of this mode of dissemination of fuel can be compared with conventional napalm type burning weapons. Napalm employs a hydrocarbon, such as benzene, gasoline, or the like, which is jelled in order to increase the viscosity so that the material leaves a substantial smear on surfaces to be burned. The burning occurs in contact with the surface leading to damage thereof. The high viscosity also helps to maintain a continuity between parts of the burning fuel streak in order to assure the spread of combustion. The burning time in conventional napalm weapons is in the order of 5 minutes so that substantial heat transfer occurs over a long time. The surface temperatures achieved are in the order of 500°F or less.

In one embodiment of an ordnance device constructed according to the principles of this invention, however, low viscosity materials are dispersed as a cloud of high velocity droplets mixed with vapor. Burning is developed throughout a pancake-shaped volume and extremely high heat flux rates are obtained in the process. Among other things high speed droplets of low viscosity fuel tend to penetrate and make a "wick" of a wide variety of materials rather than clinging to the external surface. Droplets, along with vapor, burn in the cloud although no target is encountered, thereby yielding a strong pulse of heat in the cloud with the result that any target objects are also essentially surrounded by a source of heat at very high temperature. Thus, even though the burning time is in the order of a second or less, the energy flux rates are extremely high and surface temperatures in the order of 1,500°F or higher can be obtained. Temperatures have been measured inside the flame cloud of a device constructed according to the principles of this invention by using thermocouples. The thermocouple surface is driven to temperatures of about 2,200°F in a very short time.

The mechanism of burning of a target occurring with a weapon as described and illustrated is to a large extent so called flash burning. This is a damage mechanism wherein burning is due to a very high heat flux for a short period of time as contrasted to the low heat flux and long time burning of conventional napalm weapons. Previously the only weapons giving any appreciable flash burning have been nuclear devices wherein the intense heat flux from the fireball causes burning of surfaces exposed thereto. It is found with a weapon as described and illustrated that the heat flux is sufficiently high to give flash burning of the nature found with nuclear devices. Thus the described weapon gives an effect not previously available from non-nuclear weapons and further gives blast and fragmenta-

tion effects of the same order as prior art high explosive weapons of comparable size.

In an ordnance device employing a thick layer of explosive surrounding a fuel, it is hypothesized that initial ignition of the fuel occurs substantially simultaneously with the dissemination thereof. That is, there are no requirements for secondary sequential detonation. The ignition of the fuel simultaneously or substantially simultaneously with dissemination thereof occurs because of the high quantity of explosive surrounding the fuel. This generates a large magnitude shock wave passing through the fuel which raises the temperature thereof to a regime wherein reaction occurs when the fuel contacts air. In a FAX type weapon with a center explosive burster, if initiation of combustion occurs at the commencement of dissemination of the fuel, the mixture of fuel with air is too rich, that is, the concentration of fuel is too high relative to the air to support combustion and it is definitely too high for detonation so that no explosive effects are obtained beyond the range of the high explosive itself in the absence of a secondary detonator. In the weapon described herein, on the other hand, the periphery of the cloud of disseminating fuel has a thin zone at which the ratio of the weight of air to the weight of fuel is within the detonation region. Chemical combination between the fuel and air therefore occurs in this region and because of the larger quantity of explosive contained in the ordnance device herein described, the fuel is traveling at supersonic velocity during initial dissemination of the cloud.

The hypothesized mechanism of the effect is better understood by reference to FIG. 2 wherein there is illustrated a plurality of droplets 19 traveling from left to right. Immediately preceding each of the droplets 19 by a distance of only a few microns is a small shock wave 21 since the droplets 19 are traveling at a supersonic velocity. The shock waves 21 act in concert to provide a large scale shock wave substantially at the boundary of the expanding cloud of fuel. As is well known from shock tube measurements there is a combustion zone about 0.3 to 3.0 millimeters thick behind a shock front traveling through a detonable mixture.

Examining a single droplet 19 and its associated shock wave 21 as illustrated in FIG. 3, there will be a combustion region 22 adjacent the droplet 19 wherein the concentration of fuel in the air is in the region of detonation, that is, the flame propagation rate is supersonic. The droplet 19 is well within the combustion region behind the shock front and the combustion region 22 is a portion of the overall combustion zone of the shock wave. It should also be noted that the shock wave 21 in traveling through the air is losing energy due to viscosity of the air, expansion, and conduction of heat therefrom. Energy is available, however, from the combustion region immediately behind the shock wave and this energy augments the energy of the shock wave. It therefore occurs that an energy balance is present across the shock wave wherein the reaction yield in the combustion zone is substantially equal to the shock wave energy losses due to viscosity, conduction, and expansion. When this balance is present, the shock wave will continue to propagate at substantially the same velocity instead of slowing down as energy is dissipated. In a conventional shock wave without addi-

tional energy augmentation, the velocity continually and rapidly decreases until no shock wave exists. Thus, in the described device the shock wave is augmented by continually burning fuel and the flame continues to propagate at supersonic velocity. This is possible since the droplets of fuel are initially ejected at a supersonic velocity due to the large quantity of explosive surrounding the fuel.

It is apparent that combustion of fuel from the droplet 19 in the combustion zone 22 depletes the quantity of fuel therein due to high evaporation rate in the high temperature environment of the shock wave and the droplets 19 are continuously decreased in size. The droplets 19 are traveling through air or a mixture of fuel vapor, combustion products, and air with a velocity that gives an apparent wind direction as shown by the arrow in FIG. 3. This apparent wind direction aerodynamically drags on the fuel droplets 19 and as the droplets get smaller, the affect of aerodynamic drag is proportionately larger with respect to the droplet mass and the droplets slow more rapidly.

It is apparent, however, that not all of the fuel is at the periphery of the cloud of disseminating fuel since the implosive shock wave traveling through the fuel from the explosive affects the fuel at different times. Following the leading droplets 19 as illustrated in FIG. 2 are a succession of following supersonic droplets 23 each with its associated shock wave 24. The following droplets 23 are traveling faster than the droplets 19 adjacent the shock front since the fuel has not been dissipated therefrom by combustion and the droplets are therefore larger and not as yet slowed so much by aerodynamic drag.

Thus, as the droplets 19 (FIG. 2) are depleted by combustion, additional droplets 23 arrive at the shock front and are in turn slowed by aerodynamic drag and dissipated by combustion as droplets 19. The droplets 23 following the leading edge of the disseminating cloud are not burned before reaching the shock front for substantially the same reason that the fuel does not burn in a conventional FAX weapon when the ignition is at the beginning of dissemination of the cloud, namely the mixture within the cloud behind the front is too rich for combustion. This is the case since the gases behind the shock front comprise the combustion products of the fuel, excess fuel vapor, and air that is substantially depleted in oxygen.

Although it cannot be stated with certainty that the hypothesized mechanism set forth hereinabove is actually occurring in the expanding cloud of fuel, it is known that a substantial shock wave accompanies the expanding cloud of fuel in the above described weapon and that a very substantial over-pressure is generated out to substantial distances, thereby giving blast effects as well as a severe thermal effect due to the combustion zone.

A further hypothesis concerning the mechanism of reaction when a fuel is subjected to a high energy implosion wherein the implosion is sufficiently energetic to initiate combustion in the cloud of disseminated fuel, also involves high rate dissemination of the fuel. According to this phenomenon the outwardly traveling shock wave from the high explosive surrounding the fuel creates a low pressure region behind the shock wave. The initial quantity of fuel traversing this low

pressure region may rapidly deplete the remaining oxygen therein, leaving an extremely fuel-rich or choked environment within the expanding fuel cloud which will not burn. The low pressure behind the shock wave also permits the dispersing fuel to travel at high velocity with minimized aerodynamic drag. As the fuel cloud further expands the concentration of fuel relative to the air decreases until the cloud enters a detonable region at which time the reaction between fuel and air progresses at supersonic velocity across the entire cloud volume producing a substantial blast effect as well as high thermal yield.

Despite the exact mechanism of reaction, the effects thereof can be observed in operation of such an explosive device. Thus, for example, in one instance an implosion type device was tested wherein 37 gallons of pentane was contained and surrounded by a layer of high explosive about three-eighths inch thick. For the first 2 or 3 milliseconds after firing such a device the principal effect noticed was that of the outwardly traveling shock wave from the high explosive surrounding the fuel. By about 6 milliseconds after initiation, however, the fuel had spread to a cloud diameter of about 60 feet which represents a velocity of the forefront of the fuel cloud of about 5,000 ft/sec; at about 10 milliseconds after initiation the fuel cloud was over 88 ft in diameter and a relatively small amount of burning was observed and what burning was occurring was largely obscured by the unburned fuel surrounding the implosion fireball. Shortly thereafter the cloud of expanding fuel reached a detonable mixture and the flame front rapidly propagated across the entire cloud volume. At 150 milliseconds after initiation of implosion a large fireball at extremely high temperature is spread across the ground over approximately a 100 ft circle. The fireball continues to hug the ground for a time of about one-third second to provide considerable flash burning on a target and then commences to rise from the ground. A substantial blast effect was obtained and substantial burning in the fuel cloud was still occurring after a full second. A vehicle located about 30 feet from the point of initiation of the FAX device was overturned and continued to burn for a substantial period of time after dissipation of the fireball.

It has been found that there is a threshold thickness for the explosive 16 surrounding the fuel 14 below which high energy shock waves sufficient to initiate ignition without a separate igniter are not obtained. Below the threshold, ignition may occur but the large over-pressure wave described may not be obtained. This lower threshold is found to be about one-fourth inch for conventional high explosives and can be stated as a thickness equivalent to at least one-fourth inch of explosive having a power or detonation velocity in the range of 1.0 to 1.6 relative to alphanitrotoluene (TNT) which is the power range of conventional high explosives that are relatively safe to handle, that is, are not unduly sensitive, and are suitable for military applications. It will be apparent that explosives such as nitrolycerin having higher power may be employed in thinner layers around the fuel. Similarly lower power explosives may be employed in correspondingly thicker layers. It would appear, however, that explosives having a power substantially below that of TNT may not be completely suitable since the detonation velocity in the explosive is also low.

It is found with thicknesses of high explosive less than about one-fourth inch that substantial blast effects at large distances from the center are not obtained. Large thermal effects are still present, however. On the other hand, when the thickness of explosive surrounding the fuel is greater than about ¼ inch equivalent thickness of high explosive, there is a substantial blast effect associated with explosion of the FAX type weapon hereinabove described, and also a substantial thermal effect since a very high temperature combustion zone is associated with the shock front so that the energy transfer from the extremely hot combustion zone is quite high. There is also continued burning after the shock front is dissipated due to burning of the fuel rich mixture behind the shock front. Such continued burning may persist for more than 500 milliseconds, thereby causing further thermal damage.

Thus, in a land mine of the type described and illustrated in relation to FIG. 1, substantial blast effects are obtained with large over-pressures over large distances, also accompanied with substantial thermal effects. Because of the above described effects, a weapon constructed according to the principles of this invention provides greater destructive capability than previously known weapons whether measured on the basis of effectiveness per unit weight of the explosive device or unit cost of the explosive device. This latter factor is because of the relatively smaller quantity of high explosive required in the FAX type weapon as compared with the high explosive weapon and the relatively cheap fuel employed to obtain the effect as well as the increase in area of effective coverage per unit weight.

In addition to the blast and thermal effects obtained from an explosive device as hereinabove described, extensive fragmentation effectiveness is also readily obtained. If desired an outer frangible container can be provided to form shrapnel which is ejected at high velocity by the high explosive surrounding the fuel. In a preferred arrangement, a plastic foam layer is provided around the high explosive, either with or without a container. Imbedded within the foam are a plurality of flechette type darts which cause severe shrapnel damage. Similarly belts of flechette fragments can be wrapped about the FAX type weapon or other fragmentation means provided. It has been found that with a mine as described, a density of fragments of 0.5 per square foot is readily obtained at a distance of 60 feet from the center.

It will be apparent since the ordnance device herein described is highly effective from the point of view of weight and volume, that it is also particularly suitable as an aerial bomb, artillery shell, mortar shell, missile warhead or the like. A typical aerial bomb is illustrated in FIGS. 4 and 5 which comprise respectively longitudinal and transverse sections of a preferred aerial bomb. Thus, as illustrated in FIG. 4, there is provided a cylindrical aluminum case or canister 26 about 5 inches in diameter and 9 inches long which may, for example, be one-eighth inch thick or slightly less. In order to provide a structural container for the aerial bomb, a top end plate 27 which preferably comprises an aluminum plate approximately one-half inch thick is either formed integral with the cylindrical housing 26 or can be otherwise secured thereto as will be apparent to one skilled in the art.

On the outside of the top end plate 27 there is provided a detachable pusher cap 28 which can be employed for ejecting the aerial bomb from its attachment to an aircraft. Within the pusher cap 28 is preferably a small conventional parachute 29 which is secured to the top end plate 27 by way of riser lugs 31. The parachute is employed not so much for decreasing the vertical velocity of the aerial bomb as for reducing horizontal velocity and thereby providing stabilization thereof so that it falls substantially vertically with the top end plate upward and the axis of the cylindrical device substantially vertical upon impact. It will be apparent that in lieu of a conventional parachute, other suitable drag devices or stabilization means can be employed.

Centered within the cylindrical canister 26 is a liner 32 which is constructed of conventional plastic material or preferably nitrocellulose. Nitrocellulose is preferred so that most of the materials of construction are explosively effective and the nitrocellulose has sufficient structural strength to support other elements of the aerial bomb. The liner 32 is preferably bonded to the upper end plate 27 by conventional epoxy resin so that an effective seal is obtained therebetween. The liner 32 is closed at the bottom end thereof so that a substantially closed chamber is obtained. A small hole 33 is provided in the bottom of the liner 32 for filling thereof as described hereinafter. An explosive 34 such as RDX, PETN or other suitable military high explosive is cast or otherwise placed between the liner 32 and the outer metal canister 26. The thickness of explosive 34 is preferably at least one-fourth inch in order to obtain the described effects. Within the liner 32, there is provided a body of fuel 36 which is preferably naphthalene, polyethylene, gasoline, or other fuels as described hereinabove. Within the liner 32 and in contact with the fuel 36 there is provided a closed gas containing or evacuated volume as defined by a bellows 35. This resilient volume is provided for accommodating thermal expansion differences due to operation of the aerial bomb in various temperature regimes, thereby preventing damage to the aerial bomb.

Axially located within the liner 32 is a frangible tube 37 of a brittle plastic material such as Micarta or polystyrene, or glass or nitrocellulose. Within the frangible tube 37 there is a mixture of powdered materials capable of undergoing an exothermic reaction therebetween as described hereinabove. Preferred mixtures of materials are stoichiometric mixtures of copper oxide and aluminum or magnesium and zirconium oxide. As is well known, these materials will react when initiated to produce aluminum oxide and copper, or zirconium and magnesium oxide, respectively, at elevated temperature. It is also preferred that controlled void spaces be provided within the mixture of reactive materials for elevating the temperature thereof and initiating reaction as described hereinabove.

At the bottom end of the aerial bomb there is provided a bottom end plate or base plate 39 which is also illustrated in the sectional view of FIG. 5. The base plate 39 is secured to the canister 26 peripherally by shear pins 41 or other means as will be apparent to those skilled in the art. It is preferred that the bottom end plate 39 be aluminum or aluminum alloy about five-eighths inch thick and have a 1 inch by $\frac{1}{8}$ -inch well

42 running transversely thereof for containing a fuse and detonator assembly 43 and an electrical power supply 45. The explosive portion of the detonator assembly 43 is arranged adjacent a hole 44 extending between the transverse well 42 and the upper surface of the bottom end plate 39. A shallow slot 46 runs from the hole 44 toward the center of the bottom end plate 39 and four radially extending shallow slots 47 extend from the center of the plate to the periphery thereof. As assembled, a strip of explosive is laid in each of the grooves 46 and 47 so that when the explosive portion of the detonator 43 is initiated the detonation traverses the hole 44 and initiates detonation in the explosive strip in the groove 46. The detonation wave in the explosion then follows the explosive strips in the grooves 47 so as to arrive at the periphery of the bottom plate and the primary explosive 34 at four points around the periphery thereof substantially simultaneously. This assures that a symmetrical detonation wave propagates upwardly through the primary explosive 34 for disseminating the fuel 36 and initiating ignition thereof as hereinabove described.

The detonator assembly comprises a conventional electric detonator 43 and conventional electric power supply 45 such as a battery as will be apparent to those skilled in the art. At the periphery of the bottom end plate and arranged to extend through the canister 26, there are one or more arming switches 48 actuated upon ejection of the aerial bomb from the aircraft carrying it. The arming switches 48 may be used to unshunt the electric detonator for arming the aerial bomb. On the bottom surface of the bottom end plate 39, there is provided a contact switch assembly comprising an inner dish shaped resilient plastic member 49 and an outer dish shaped resilient plastic member 51 substantially concentric therewith. A conductive metal layer 52 is provided on the outer surface of the inner dish shaped member 49 and a conductive metal surface 53 is provided on the inner surface of the outer dish shaped switch member 51. The dish shaped plastic members 49 and 51 and the metallic layers 52 and 53 thereon are illustrated as relatively thick in FIG. 4 only for purposes of illustration. In a typical embodiment the plastic members may be about 0.05 inch thick or less and the metallic layer about 0.001 inch or less. The inner and outer metallic layers 52 and 53 are electrically insulated from each other and are electrically connected in series between the power supply 45 and electric detonator 43. When the metallic layers 52 and 53 are out of contact, they act as an open switch and prevent firing of the detonator. Upon impact with a target, the outer dish shaped plastic member 51 is deformed against the inner dish shaped plastic member 49, thereby closing the contact between the metallic layers 52 and 53 and acting as a switch applying power to the detonator and initiating explosion of the aerial bomb.

In fabricating the aerial bomb described and illustrated in FIGS. 4 and 5, the canister 26 and top end plate 27 are formed integrally or joined together and the parachute 29 is rigged and packed within the pusher cap 28. The igniter assembly 37 and 38 is bonded to the top end plate and the pressure accommodating bellows 35 attached thereto. The nitrocellulose liner 32 is bonded in place to the top end plate 27

and also to the end of the igniter assembly 37. Conventional epoxy resins have been found suitable for the various bonding procedures. After the liner is installed, the fuel 36 is placed within the liner and the hole 33 plugged. After this operation, the high explosive 34 is cast between the liner 32 and the canister 26 and the previously assembled bottom end plate 39 is installed with the detonator assembly 43 already in place.

After assembling the aerial bomb as described and illustrated, it is ready for use. In the usual application, the aerial bomb is inserted in a tube or housing on an aircraft so that the arming switches 48 are depressed thereby shorting the detonator and preventing accidental detonation of the bomb. In use, the bomb is ejected from the housing (not shown) thereby releasing the arming switches 48 and unshorting the detonator 43. On contact with the ground or other objective the plastic dish-shaped member 51 is deformed against the inner dish-shaped member 49 thereby applying power to the detonator as hereinabove described. The explosion from the detonator traverses the hole 44 in the baseplate and along the grooves 46 and 47, respectively, to detonate the explosive 34. The imploding shockwave from the high explosive 34 acts on the fuel 36 and reactive mixture 38 in the same manner as hereinabove described in relation to the mine of FIG. 1.

In another embodiment, the principles of this invention are applied to a napalm weapon. A difficulty with conventional napalm weapons has been in initiating combustion of all portions of the scattered napalm. Napalm comprises a jelled mixture of gasoline or benzene which has a high viscosity and smears and sticks to surfaces for prolonged burning. Napalm bombs in the past have dispersed the napalm over a target by either of two mechanisms. For high altitude delivery a napalm bomb is provided with a center burster of high explosive which scatters the napalm over a substantial area. For low altitude delivery the forward momentum of the bomb is employed for dispersal. In either case an igniter may be provided for initiating combustion of the napalm and many of the scattered masses of jelled napalm are burning upon dissemination. Additional ignition of scattered masses of napalm is provided by combustion of evaporated fuel mixed with air in the vicinity of the napalm. In order to promote such combustion relatively volatile hydrocarbons such as benzene or pentane are incorporated in the napalm to provide a combustible fuel mixture with air. It is found, however, that high altitude delivery of napalm bombs with centrally located explosive bursters is not highly effective and it is preferred that low level, high speed drops of napalm bombs be made. It is found, however, with either high altitude, center burster bombs or with low altitude bombs that substantial quantities of napalm are often present on the target area after combustion is completed. This unburned napalm represents a diminished effectiveness of the napalm weapons.

In addition to the relative ineffectiveness of napalm weapons due to unburned fuel, the delivery problem of aerial bombs is considerable. Thus, low altitude airplane flights which provide the most effective distribution of napalm also subjects the aircraft to dangerous ground fire. It is, therefore, desirable that a highly effective high altitude napalm weapon be available. It is

also found with low altitude deliveries that the area covered by a napalm bomb in the order of 200 lbs, for example, is about 8 feet wide and 150 feet long. This elongated pattern is due to the high horizontal velocity of the bomb upon striking the ground.

FIG. 6 comprises a cutaway section of a portion of a cylindrical ordnance device constructed according to the principles of this invention, illustrating both transverse and longitudinal sections of the device. It will be apparent to one skilled in the art that conventional arming, fusing, and detonating means can be provided with a device of this type in the same manner as hereinabove described. In a preferred embodiment the ordnance device of FIG. 6 comprises an aerially delivered high altitude napalm bomb or the like.

Thus there is provided a metal or plastic case 56 forming the outer shell of the aerial bomb which may be about 15 inches diameter and weigh 200 pounds. Within the container 56 is a quantity of napalm 57 or similar combustible fuel. Coaxially with the container 56 there is provided an igniter and burster which comprises a frangible tube 58 within which is contained a layer of high explosive 59. Within the layer of high explosive 59 is a second frangible tube 61 which, in turn contains a reactive mixture 62 which preferably comprises a mixture of aluminum and copper oxide or magnesium and zirconium oxide having controlled void spaces filled with gas therein as hereinabove described. The tube 61 is preferably about five-eighths to 1 1/4 inch in diameter. The frangible tubes 58 and 61 can, for example, comprise Micarta, phenolic resin, or other relatively brittle plastic that is inert to the napalm fuel 57; the tube 58 thereby prevents leaching action of the fuel on the high explosive 59 and also provides structural support therefore. In a typical aerial bomb the layer of high explosive 59 may be about 0.05 inch thick so as to provide a high energy converging shock wave in the reactive mixture 62 for initiation of reaction therein and an outwardly traveling wave for disseminating the napalm.

It is found with a 200 pound weapon as described and illustrated in FIG. 6 having napalm and a combined center burster and igniter that an effective area of coverage of napalm is obtained over a 200 ft diameter circle. Thus the effective area of coverage is over 15 times as large as with a conventional, low level, 200 pound napalm weapon which covers an area of about 8 by 150 feet.

The high effectiveness of the napalm weapon described and illustrated in FIG. 6 is largely due to the implosive center burster and igniter present in the center of the aerial bomb. If an equivalent amount of high explosive were employed as a cylindrical center burster without the reactive mixture contained therein, some dispersion of the napalm occurs but not to the large extent obtained with the implosive burster and igniter. In addition, because of the quenching effect of the large quantity of napalm, no substantial amount of ignition thereof occurs due to the explosive alone. When an implosive arrangement of high explosive having a reactive mixture in the center thereof is employed in a napalm weapon, on the other hand, the high explosive serves to commence dissemination of the napalm in somewhat the same manner as a center burster due to the action of an outwardly traveling shock wave

from the high explosive and expanding reaction products. However, concurrent with the outwardly traveling shock wave there is an imploding shock wave traveling through the reactive mixture. An extremely high pressure is obtained due to the convergence of the shock wave, higher than the peak pressure from cylinder of high explosive, and this wave follows the outwardly traveling shock wave a short time thereafter, and a very large force is thereby produced for further propelling the napalm outward. The fragments of reactive mixture in the igniter which are ejected by the imploding shock wave also tend to accelerate the napalm outwardly and further break up the mass of napalm for uniform distribution. Further, as hereinabove described, the fragments of reactive mixture from the igniter serve to initiate combustion of isolated masses of the napalm mixture and clouds of evaporated fuel after dissemination has progressed a substantial distance from the point of initiation.

In still another embodiment of this invention organic materials which react to produce elevated temperatures may be employed as igniters. Thus, for example, concentrically oriented tubes of hypergolic fuels along the axis of symmetry produces an evolving cloud of very high temperature gas which functions as a source of ignition. By purposefully producing deviations from symmetry in the tubes and the explosive, jets of the hypergolic liquids may be produced which enhance the ignition effects by a turbulent mixing within the jets. The hot, gas jets so produced travel at high velocities and provide a multiplicity of ignition sources within a dispersing cloud of fuel.

Thus FIG. 7 illustrates in partial cutaway section another embodiment of a fuel-air explosive apparatus incorporating the principles of this invention. According to this embodiment a metal or plastic cylindrical case 66 is provided as a container for the explosive device. Within the container 66 there is located a quantity of combustible fuel 67 such as gasoline, napalm or the like. Coaxially arranged within the container is a central burster and igniter which comprises three concentric tubes 68, 69, and 70 respectively, each of which is preferably constructed of a frangible material, such as brittle plastic as hereinabove described. The outermost of the tubes 68 preferably comprises a square cross-section uniform along its length. The innermost tube 70 preferably comprises a uniform cylindrical tube. The intermediate tube 69 has a generally square cross-section with a plurality of convolutions along the length thereof; that is, the tube is periodically pinched together on two or four of its sides. In another embodiment the tube 69 may comprise a member having a helical convolution which provides substantially the same effect as the periodic convolutions described and illustrated.

Between the outermost tube 68 and the intermediate tube 69 there is provided a high explosive 71 which is preferably cast in place so as to conform to the convolutions of the intermediate tube 69. Between the intermediate tube 69 and the inner tube 70 there is provided a first hypergolic material 72 and within the innermost tube 70 there is provided a second hypergolic material 73. Hypergolic materials 72 and 73 are selected from pairs of materials that are spontaneously and exothermically reactive merely upon contact

therebetween. Many pairs of hypergolic materials are known which generate extremely high temperatures upon chemical reaction therebetween. The temperatures produced may be several thousand degrees Fahrenheit and the products of the hypergolic reaction may in turn be combustible with air. Typical pairs of hypergolic materials suitable for use in the practice of this invention include: unsymmetrical di-methyl hydrazine, and nitrogen tetroxide; penta borane and tetranitro methane; and alpha-penane and chlorine pentafluoride.

In use of an ordnance device as described and illustrated in FIG. 7 the high explosive 71 is detonated by a conventional detonator as will be apparent to one skilled in the art. The detonation of the high explosive causes an expanding shock wave to travel outwardly through the fuel 67 followed by a substantial volume of explosive reaction products, both of which tend to accelerate the fuel outwardly as has been described hereinabove. The inner surface of the high explosive 71 is convoluted to conform to the convolutions of the tube 69 and therefore the high explosive acts as a plurality of shaped charges arranged adjacent to each other. These shaped charges create a plurality of very vigorously mixed regions of the hypergolic fuels 72 and 73 and create a plurality of radiating jets of the mixed and mixing hypergolic materials. Thus there is provided a large number of very high temperature jets of the hypergolic materials traveling outwardly through the expanding cloud of fuel 67 for providing a plurality of ignition sources within the cloud in a manner analogous to the ignition sources providing by the reactive mixtures hereinabove described. The hypergolic materials may be preferred in many applications because of the high energies available per unit weight, and because of the elevated temperatures of the reaction, they may contribute substantially to the thermal effects obtained from a FAX type weapon.

It will be apparent to one skilled in the art that an igniter alone without surrounding fuel also makes a highly desirable ordnance device. In this type of device a reactive mixture as hereinabove described and illustrated is contained within, and substantially surrounded by, a layer of high explosive sufficient to initiate reaction in the reactive mixture and cause dissemination thereof. Such a weapon has a minimal blast effect which is due only to the high explosive employed. However, substantial fragmentation can be provided in addition to the fragmentation due to the reactive material alone. As hereinabove pointed out, the reactive material is ejected in a plurality of fragments, each of which may penetrate structural material and each of which is at extremely elevated temperature. The fragments of reactive mixture thus serve as a very effective incendiary material. It will also be apparent to one skilled in the art that in addition to the mine and aerial bomb described and illustrated, that the principles of this invention are readily applicable to artillery and mortar shells, missile warheads and the like merely by changing the containing structures and fuzing in conventional ways.

It will also be apparent to one skilled in the art that other arrangements of igniter are possible using a converging shock wave. Thus, for example, the igniter mixture described can be combined with a conventional

conical shaped charge of high explosive. The igniter mixture is arranged as a thin layer within a conical cavity in the explosive in substantially the same manner as copper or other metals have been employed in the past. Firing of such a device produces a jet of reacting and reacted igniter material at very elevated temperature. As such the shaped charge having an igniter mix has greater penetrating power than a conventional shaped charge of high explosive.

In effect what is described above in relation to the igniter and the powdered fuel is a means for heating the solid materials to elevated temperature in a very short time. There is provided a porous solid and means for passing a high energy shock wave through said solid so that the gas which is in the void spaces in the solid is heated to an elevated temperature and the heat is, in turn, passed to the solid. If desired additional dispersed gas filled void spaces of controlled size and proportion may be provided in the porous solid. Such a solid, rapidly heated to elevated temperature by a shock wave, may be employed in other manners than in a military weapon such as, for example, for generating high pressure, high temperature vaporized solids for research purposes, driving projectiles, or the like. As such it will be recognized that it may not be necessary in every instance to provide a converging shock wave. If a high explosive of sufficient size is employed a high energy flat shock wave may be satisfactorily produced. Further, if the porous solid is bounded, at least on some sides, by materials having a high impedance mismatch for shock waves, intense heating is obtained and substantial dwell times of the shock waves in the porous solids are obtained.

A preferred embodiment employs a reactive porous solid subject to a shock wave for generating additional energy by exothermic reaction after initiation by the shock wave. The reactive porous solid is preferably a powdered element of the variety consisting of lithium, potassium, cesium, barium, calcium, sodium, magnesium, beryllium, aluminum, titanium, zirconium, and carbon and a powdered compound such as an oxide, halide, carbide, sulfide, boride, nitride, silicide or phosphide of a metal such as magnesium, beryllium, aluminum, titanium, zirconium, manganese, vanadium, zinc, chromium, iron, cadmium, indium, cobalt, nickel, molybdenum, tin, lead, copper and mercury. The free element is preferably substantially more electropositive than the metal in the compound so that a large amount of energy is released by the reaction and the reaction products are heated to an elevated temperature.

It is to be understood that the above described embodiments are merely illustrative of application of the principles of this invention. Those skilled in the art may readily devise other variations that will embody the principles of the invention. It is, therefore, to be understood that within the scope of the appended claims the invention may be practiced otherwise than as specifically described.

What is claimed is:

1. A fuel-air explosive device comprising:
 - a cylindrical body of fuel;
 - a housing around the fuel;
 - a layer of high explosive around the housing, the thickness of said layer being sufficient to disseminate said fuel at a velocity substantially

greater than the combustion velocity of said fuel with air;

means for detonating said high explosive; an igniter for said fuel located within said body of fuel;

said igniter comprising:

a frangible tube substantially coaxial with said cylindrical body of fuel;

a mixture of two materials within said tube, said two materials being exothermically reactive together in response to detonation of said high explosive, and means forming a plurality of controlled void spaces within said mixture of materials;

the first of said two materials being selected from the group consisting of lithium, potassium, cesium, barium, calcium, sodium, magnesium, beryllium, aluminum, titanium, zirconium, and carbon;

the second of said two materials being selected from the group consisting of oxides, halides, carbides, sulfides, borides, nitrides, silicides, and phosphides of the metals magnesium, beryllium, aluminum, titanium, zirconium, manganese, vanadium, zinc, chromium, iron, cadmium, indium, cobalt, nickel, molybdenum, tin, lead, copper, and mercury;

said first material being substantially more electropositive than the metal of said second material;

first and second ductile end plates at opposite ends of said cylindrical body of fuel, said end plates having a substantial sonic velocity mismatch with said fuel for reflecting a shock wave; and

said means for detonating the high explosive comprising a fuze and detonator carried by the housing adjacent an end plate.

2. An explosive device as defined in claim 1 wherein said fuel is selected from the group consisting of

propane, butane, pentane, hexane, heptane, octane, nonane, decane, undecane, dodecane, ethylene oxide, polyethylene, propylene oxide, polypropylene, polystyrene, styrene, butene, butadiene, isobutylene, pentene, hexene, heptene, octene, ethylacetylene, acetylene, dimethylacetylene, pentene, methyl butene, hexene, benzene, toluene, naphthene, ethyl benzene, propylbenzene, butyl benzene, xylene, mesitylene, mesityl oxide, cumene, pseudocumene, indane, naphthalene, methyl naphthalene, diphenyl, acenaphthalene, fluorene, phenanthrene, anthracene, fluoranthene, pyrene, benzopyrene, chrysene, naphthacene, pyridine, picoline, quinoline, quinaldine, indole, acridine, carbozole, allylbenzene, stilbene, diphenylmethane, triphenyl methane, tetraphenyl methane, terphenyl, camphor, methyl alcohol, ethyl alcohol, propyl alcohol, butyl alcohol, amyl alcohol, hexyl alcohol, phenol, benzyl alcohol, diethyl ether, methyl ethyl ether, dipropyl ether, diphenyl ether, methyl phenyl ether, dioxane, methyl butyl ether, ethyl butyl ether, dibutyl ether, diamyl ether, dihexyl ether, divinyl ether, tetrahydrofuran, acetaldehyde, benzaldehyde, propionaldehyde, butyraldehyde, valeraldehyde, acrolein, crotonaldehyde, benzaldehyde, furfural, acetone, methyl ethyl ketone, methyl propyl ketone, diethyl ketone, hexanone, methyl butyl ketone, dipropyl ketone, dibutyl ketone, diamyl ketone, chloracetone, methyl

amine, dimethyl amine, trimethyl amine, ethylamine, diethylamine, triethylamine, propylamine, dipropylamine, tripropylamine, butylamine, amylamine, hexylamine, ethylene diamine, trimethylene diamine, allylamine, aniline, acetamide, propionamide, benzamide, nicotinonitrite, flour, glucose, fructose, sucrose, lactose, maltose, cellulose (such as, for example, cotton, sawdust, straw, paper), butyric acid, isovaleric acid, caproic acid, caprylic acid, capric acid, lauric acid, myristic acid, palmitic acid, stearic acid, paraffin, charcoal, coconut oil, palm oil, olive oil, castor oil, peanut oil, corn oil, rape oil, beef tallow, lard, whale blubber, cottonseed oil, soybean oil, tung oil, linseed oil, gasoline, kerosene, jet engine fuel, bunker oil, gas oil,

20

25

30

35

40

45

50

55

60

65

lubricating oil, petroleum ether, mineral spirits, heavy ends from petroleum refining, asphalt, waxes, lacquer, napalm, furan, ethyl nitrate, furfural, ethyl cellulose, nitromethane, nitrobenzene, dinitrobenzene, nitroethane, nitropropane, nitrobutane, nitropentane, light oil, carbolic oil, creosote oil, anthracene (or green) oil, pitch, fusel oil, starch, polyvinyl chloride, polyvinyl alcohol, epoxy polymers, mercaptans, and glycol, including cyclic and branched chains, polymers, and saturated and unsaturated isomers thereof, nitrate, ammonia, sulfhydryde, and cyanide substitutions thereon and heterocyclic chains with nitrogen, oxygen, phosphorus, and sulfur.

* * * * *