

[54] **FIRING DELAY FOR POINT DETONATING FUZE**

3,371,608 3/1968 Webb..... 102/79 X

[75] **Inventors:** William J. Donahue, Takoma Park; Peter D. Gratton, Simpsonville; Thomas A. Cammack, Beltsville; Robert L. Schmidt, Silver Spring, all of Md.

Primary Examiner—Verlin R. Pendegrass
Attorney, Agent, or Firm—R. S. Sciascia; J. A. Cooke; C. I. McClelland

[73] **Assignee:** The United States of America as represented by the Secretary of the Navy, Washington, D.C.

[57] **ABSTRACT**

[22] **Filed:** Dec. 20, 1968

A mechanical delay for point detonating fuzes for projectiles to allow penetration into aircraft or similar light target structures before detonation of the projectile. A trans-axial inertial firing pin is mounted within the projectile so that the centrifugal force exerted thereon by the spinning projectile during light target penetration will selectively determine the firing time delay. Alternatively, instantaneous detonation is provided by a second, axial firing pin when the projectile strikes an impenetrable target or one of such hardness that would break up the projectile before the trans-axial firing pin could react to provide the normal delayed detonation.

[21] **Appl. No.:** 788,984

[52] **U.S. Cl.**..... 102/79, 102/82

[51] **Int. Cl.**..... F42c 15/22

[58] **Field of Search**..... 102/71, 72, 74, 79, 80, 82

[56] **References Cited**

UNITED STATES PATENTS

2,609,753 9/1952 Rosenberg 102/79 X

9 Claims, 3 Drawing Figures

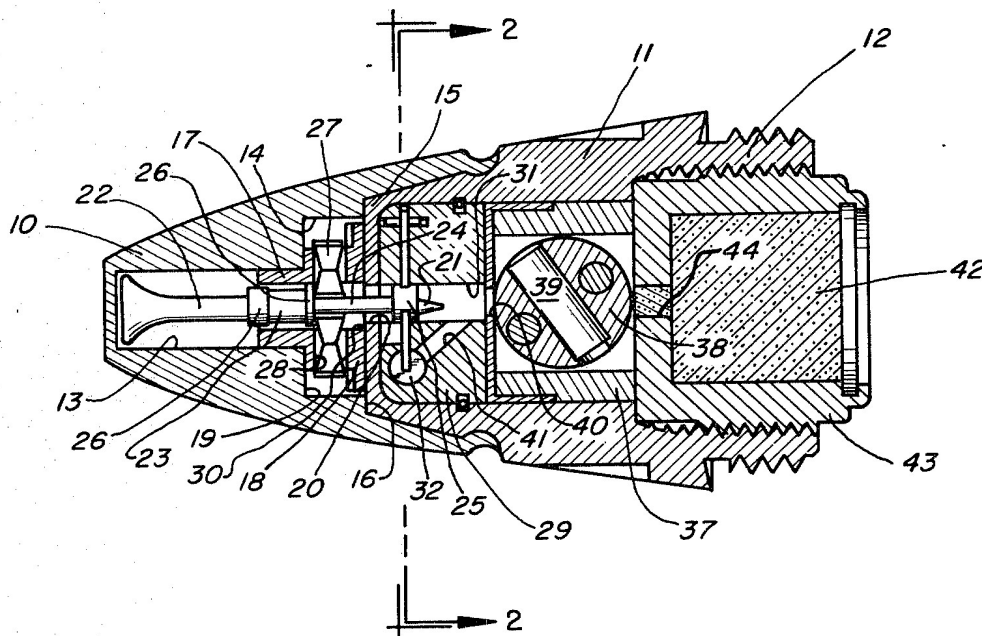

PATENTED JAN 22 1974

3,786,754

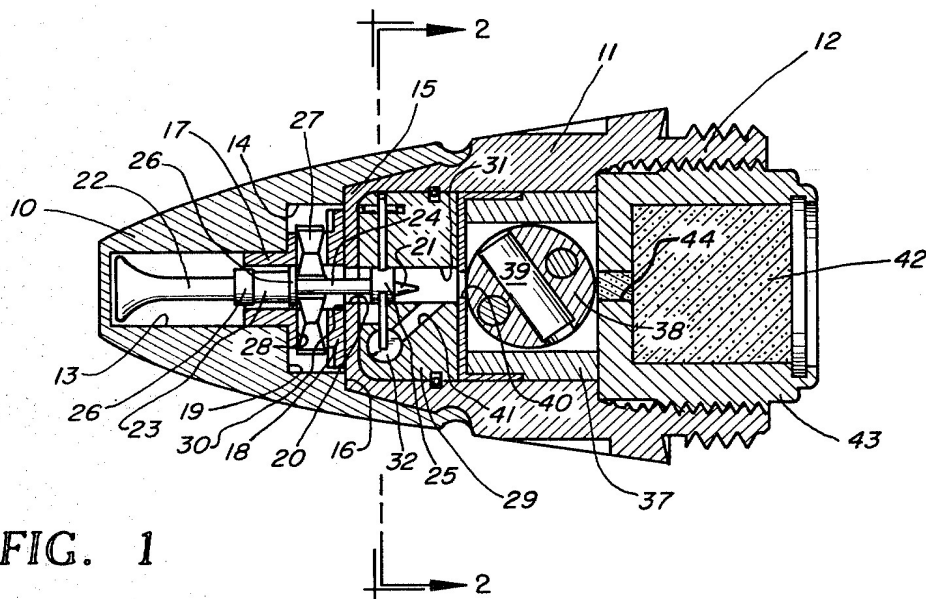

FIG. 1

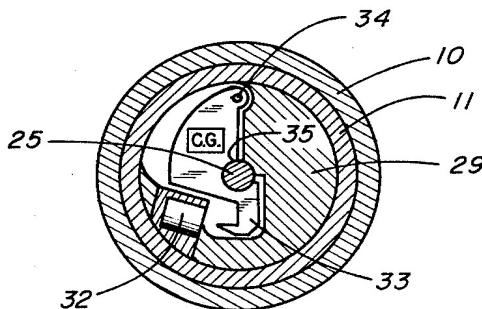

FIG. 2

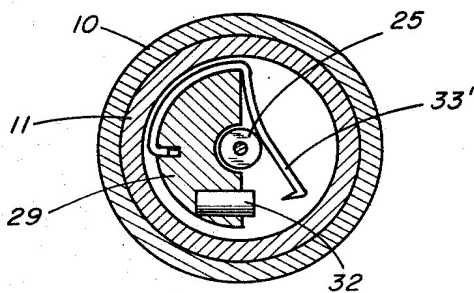

FIG. 3

INVENTORS

William J. Donahue
Peter D. Gratton
Thomas A. Cammack
Robert L. Schmidt

J.O. Treasler
ATTORNEY
Erwin McLelland
AGENT

FIRING DELAY FOR POINT DETONATING FUZE**BACKGROUND OF THE INVENTION**

This invention relates generally to point detonating fuzes for spinning aerial ordnance vehicles and more particularly to a mechanical firing delay for use with point detonating fuzes to allow penetration into aircraft or similar target structures before detonation of the fuze.

Various systems have been proposed in the past to achieve a time delay after target impact. Among these is the pyrotechnic delay which, on impact, is initiated and under ideal conditions will burn at a precalculated rate. At the end of the burning time the main charge is detonated. However, the pyrotechnic delay of the magnitude required is expensive, unpredictable, and difficult to reliably reproduce.

Another form of a firing delay heretofore proposed utilizes the inherent inertia of a mass or plunger allowed to move axially within the projectile. On impact the projectile is slowed down due to skin friction on the target but the plunger retains a portion of its forward velocity to impact an explosive charge and thereby detonate the main charge. Unfortunately, on light targets such as, for example, an aircraft wing structure, there is only slight resistance to the projectile so that the inertial plunger permits too much delay or may not even detonate the fuze because of its insensitivity. On the other hand, on relatively "hard" light targets the inertial plunger may operate too rapidly and not provide sufficient delay to insure adequate penetration of the target.

Yet another known form of delay is that made up of a series arrangement of alternate firing pins and primers. On impact the first firing pin strikes the ignites the first primer. A finite amount of time is required for the pressure and temperature to rise sufficiently to force the second firing pin into the second primer. The amount of time delay depends upon the number of firing pins and primers used. Besides the problems of cost and surveillance, the accuracy and repeatability of this type delay leave a lot to be desired. It is possible, for example, that one firing pin or primer could be bypassed in the process due to gas leakage to cause unpredictable results. Also, on extremely hard impacts, the fuze may break up before the primer detonates the main charge.

SUMMARY OF THE INVENTION

An object of the present invention is the provision of a firing time delay for a point detonating fuze capable of distinguishing the degree of rigidity of the target structure and automatically providing an optimum time delay corresponding to the light target thickness to insure that the projectile fully penetrates the target before detonation occurs.

Another object of this invention is to provide a mechanical firing time delay for a point detonating fuze permitting instantaneous detonation of the fuze on hard or impenetrable targets and operative to provide a time delay directly proportional to the relative thickness of light targets.

Briefly, in accordance with the present invention, the cost, surveillance, accuracy and reliability problems associated with other types of delays like the pyrotechnic, inertial plunger, or series of primer firing pins, are elim-

inated and the foregoing and other objects are attained by a mechanical firing delay having a trans-axial inertial firing pin mounted within the projectile so that the centrifugal force exerted thereon by the spinning projectile during target penetration determines the amount of delay.

On impact with a light target two options are available to the fuze, one for a target of very light structure and the other for a relatively hard target. If it is "extremely" light such as, for example, a wing of an aircraft, the target offers little resistance to slow the projectile. Accordingly, the spin rate and forward velocity does not appreciably decrease from that prior to impact. Only a very short delay need be provided in such a case so that detonation occurs before the projectile passes completely through the target. Since the centrifugal force is a function of the angular spin rate, the delay afforded by the trans-axially mounted inertial firing pin of the present invention would be short for this case.

On the other hand, if the light target is a relatively hard one, there is more resistance tending to bring the projectile to rest, thereby requiring a slightly longer delay so that detonation does not occur until the projectile has been able to fully penetrate the target. The decay of angular velocity of the projectile is proportional to the thickness of the punctured medium. The greater thickness of a relatively hard target thereby provides a proportionately larger decrease in the angular velocity of the projectile. In this case the centrifugal force is greatly reduced and, in turn, more time is required for the transaxially mounted inertial firing pin to impact the primer.

On impacts with very hard or impenetrable targets it is desirable to have instantaneous fuze detonation before the projectile breaks up with resultant ineffective action. According to the present invention, an additional overriding firing pin is provided within the fuze, mounted axially therein and normally constrained by an arrested shear flange, to instantaneously detonate the fuze on impact with extremely hard targets such as, for example, motor mounts or the like.

BRIEF DESCRIPTION OF THE DRAWINGS

A more complete appreciation of the invention and many of the attendant advantages thereof will readily be apparent as the same becomes better understood by reference to the following detailed description when considered in connection with the accompanying drawings wherein:

FIG. 1 is a sectional view of a fuze illustrating one embodiment of the present invention shown in the safe condition and taken along the spin axis of the fuze;

FIG. 2 is a cross-sectional view of the embodiment of FIG. 1 taken on the line 2—2 thereof; and

FIG. 3 is a cross-sectional view of another embodiment of the present invention taken along substantially the same plate as FIG. 2.

DESCRIPTION OF PREFERRED EMBODIMENTS

Referring now specifically to the embodiment illustrated in FIGS. 1 and 2 there is shown a fuze adapted for attachment to a spin stabilized projectile. The fuze is comprised generally of a forward body portion 10 and a mid-support structure 11 secured to the aft end thereof and having a reduced, rearwardly extending,

threaded portion 12 for connection to the nose of a projectile.

An axial bore 13 is formed in fuze body 10 which is closed at the forward end thereof by a thin layer of metal of which the fuze body is constructed such as, for example, aluminum, and having a counterbore 14 open to the rear of the body 10. The forward portion 15 of support 11 abuts an edge 16 of body 10 surrounding the open counterbore 14 and substantially closes the counterbore. A generally tubular member 17 of the same external diameter as bore 13 is inserted coaxially therein and is provided at one end with a thick flanged portion 18 which extends laterally into the counterbore 14 where it is held in place in a shuttling relation with the fuze.

interbore 14 and the forward portion 15 of support 11 upon connection of support 11

within bore 13 of fuze body 10 and the tubular insert member 17 and an aperture 20 centrally formed in a portion of mid-support 11 is an axial elongated firing pin 22. The firing pin includes an arcuate portion 23 near its mid-section, and a cross-section, a flange or rib thereon and a stabber 21. The rims 26 of the tubular insert 17. To prevent movement of firing pin 22 during normal handling operations in the counterbore area 14 of support 11, a plurality of detents 27 positioned around the transverse apertures 28 in the side of insert 17, which normally are bilobed like portion 24 of firing pin 22 and the insert bore so as to contact and prevent lateral displacement of the spool

support 29 having an axially disposed forwardly secured within main support bore 31 and the forward wall aperture 20 of the same diameter, which in turn is of the same diameter as the insert bore thereby preventing movement of the firing pin 22 hereinafter set forth.

Cylinders 29 are a primer 32 and an inertial firing pin 33 therefor pivotally positioned eccentrically and centered on the axis of the fuze body 10. The center of gravity of firing pin 33 is near the point indicated thereon and the firing pin therefore is adapted to swing about the pivot pin 34 under the influence of the centrifugal force of the spinning projectile in which the fuze is mounted to impact the primer 32. The firing pin 33 is provided with an arcuate shaped recess 35 in the side of axial firing pin 22 which is within bore 31 of the cylindrical support 29, as best illustrated in FIG. 2, for restraining the pin 33 from any rotation about pivot pin 34 even when substantial centrifugal force experienced during the spinning of the projectile.

In the fuze assembly, a housing 37 is provided having mounted therein a detonator 39 diametrically therethrough. In FIG. 2, a line of communication is provided between the firing pin 22 and the detonator 39 formed centrally in housing 37 and supported by support 29 and to a passageway 41, also supported by support 29, for providing communi-

cation to the primer 32. A booster charge 42 is mounted on support 11 at the aft end thereof, the housing 43 therefor having a central axial aperture 44 formed in the forward wall thereof aligned with aperture 40 of housing 37 to provide a detonation path to booster 42 when the rotor 38 is moved to the armed position.

In operation, after the projectile is fired, the centrifugal forces developed by the spinning projectile cause rotation of rotor 38 to align detonator 39 therein with firing pin 22 and apertures 40 and 44. Detents 27 are also spun out by the centrifugal force attendant thereon, thereby releasing the firing pin for axial movement.

On impact with a light target only the forward end portion of the aluminum housing of fuze body 10 is crushed allowing the axial firing pin 22 to be displaced until the aft rim 26 thereof is arrested by step 30. This displacement positions the rod portion 24 of firing pin 22 in generally the same location formerly occupied by rib 25, so that it passes perpendicularly through the plane of the trans-axial firing pin 33. Since the cross-sectional area of rod 24 is less than that of rib 25, the arcuate portion 35 of the firing pin 33 is no longer engaged by any part of the axial firing pin 22. Accordingly, this impact-produced movement of axial firing pin 22 effectively acts to release the trans-axial inertial firing pin 33 for rotation about its pivot point 34.

Centrifugal force rotates firing pin 33 into contact with the primer 32, ignition of which generates ignition through path 41 of detonators 39, and in this manner a firing delay time which is directly proportional to the relative light target thickness is achieved. On an extremely light target, for example, the projectile spin rate would not decrease significantly, and since the centrifugal force is a function of the angular spin rate, the delay would be a short one.

If a "relatively hard" light target is impacted, the decay of angular velocity of the projectile is proportional to the thickness of the punctured medium. A greater thickness therefore gives a proportionately larger decrease in the angular velocity, thus decreasing the centrifugal force on the inertial firing pin 33. In turn, more time is required for the firing pin 33 to impact the primer 32.

In the event a very hard or impenetrable target is impacted, the movement of axial firing pin 22 is not arrested by the step or shoulder 30, as on soft targets, but the aft rim 26 is sheared therefrom allowing the axial firing pin 22 to strike the detonator 39 directly. Instantaneous detonation therefore occurs with impact on hard targets, thereby circumventing the possibility of the projectile breaking up before the trans-axial firing pin 33 can impact the primer 32 with resultant ineffective action.

FIG. 3 illustrates another embodiment of the invention wherein a firing pin spring 33' is utilized. In this alternative approach, after light target impact, the restoring moment due to the cantilever arrangement in the spring is used to fire the primer.

It may be seen therefore that, with the present invention, a mechanical firing time delay for a point detonating fuze is provided which permits instantaneous detonation of the fuze on hard or impenetrable targets but is operative to provide a time delay directly proportional to the relative thickness on impact with light targets.

ward wall 19 of counterbore 15 of support 11 and fuze body 10.

Axially positioned support 29 extends through the fuze body 10 thereafter through the forward wall 15 of counterbore 14. A gate cylindrical firing pin 33 is provided of integral spool-like form of length 24 of reduced diameter at its terminal portion 25, and a spool 23 are of substantially the same diameter as the bore through the tubular insert 17. In this arrangement there are provided detents 27 in the side of the fuze body 10 adjacent the flanged portion 18 of support 11 to be seated against the rod portion 24 of firing pin 22 and thereby extend into the counterbore 14 and prevent rotation of firing pin 22.

A cylindrical support 29 is provided through-bore 31 of support 11. The forward wall aperture 20 are of the same diameter as the insert bore thereby preventing movement of the firing pin 22 in a manner to be hereinafter set forth.

Housed within cylindrical support 29 are a primer 32 and an inertial firing pin 33 therefor pivotally positioned eccentrically and centered on the axis of the fuze body 10. The center of gravity of firing pin 33 is near the point indicated thereon and the firing pin therefore is adapted to swing about the pivot pin 34 under the influence of the centrifugal force of a spinning projectile in which the fuze is mounted to impact the primer 32. The firing pin 33 is provided with an arcuate shaped recess 35 in the side of axial firing pin 22 which is within bore 31 of the cylindrical support 29, as best illustrated in FIG. 2, for restraining the pin 33 from any rotation about pivot pin 34 even when substantial centrifugal force of a spinning projectile is experienced during the spinning of the projectile.

Moving aftwardly of support 11, a line of communication is provided for rotor 38 to align detonator 39 extending diametrically through housing 37, aperture 40, and detonator 39 is out of alignment with an aperture 40 of housing 37 open to bore 31 of support 11, also contained in support 11.

Obviously many modifications and variations of the present invention are possible in the light of the above teachings. It is therefore to be understood that within the scope of the appended claims, the invention may be practiced otherwise than as specifically described.

What is claimed as new and desired to be secured by letters Patent of the United States is:

- 1. An impact fuze for a spinning projectile, comprising:
 - a housing having a substantially cylindrical chamber formed therein with the longitudinal axis of said chamber lying along the spin axis of said projectile, a primer disposed within said housing,
 - a centrifugal force-responsive inertial firing pin for said primer mounted in said chamber for movement in a plane perpendicular to said longitudinal axis, and
 - an impact-responsive member mounted in the chamber adjacent one end thereof for movement along said longitudinal axis, said member including means for normally preventing movement of said inertial firing pin and for releasing said firing pin for movement by the existing centrifugal force upon impact of the projectile with a target, whereby firing of said primer is delayed for a time directly proportional to the relative thickness of the target is provided.
- 2. A fuze according to claim 1 wherein said impact-responsive member is an elongated rod, and said means for preventing movement of said inertial firing pin comprises flange means formed on said rod and normally engaging said inertial firing pin and movable from said engagement upon displacement of said rod along said longitudinal axis of said housing.
- 3. A fuze according to claim 2, and further including a rotor mounted in said housing adjacent the other end thereof for rotation by the centrifugal force developed by said spinning projectile from an unarmed to an armed position about an axis generally perpendicular to said longitudinal or spin axis,
 - a detonator mounted in said rotor to lie along said longitudinal axis in said armed position, and
 - means providing communication between said primer and said detonator when said rotor is in said armed position.
- 4. A fuze according to claim 3 wherein said elongated rod comprises a firing pin for said detonator, and further including means for normally preventing said elongated rod from moving along said longitudinal axis beyond a predetermined point to thereby prevent direct detonation of said detonator by said rod, said means being yieldable to an impact force of the degree encountered with an impenetrable target.
- 5. A fuze according to claim 4 wherein said means for preventing said rod from movement beyond a predetermined point comprises:
 - an integral shear flange on said rod, and
 - an arresting shoulder on said housing in the path of

- movement of said shear flange portion only of said rod.
- 6. A fuze according to claim 5, and further including a plurality of spin-out detents positioned within housing passages perpendicular to said longitudinal axis of said chamber and engaging said shear flange, whereby said rod is prevented from longitudinal displacement under normal handling conditions but is freed when the detents are disengaged therefrom by centrifugal forces developed by said spinning projectile.
- 7. An impact fuze for a spinning projectile, comprising:
 - a housing having a substantially cylindrical chamber formed therein with the longitudinal axis of said chamber lying along the spin axis of said projectile, a primer disposed within said housing,
 - a cantilever spring firing pin mounted in said chamber for movement in a plane perpendicular to said longitudinal axis and being resiliently biased toward contact with said primer,
 - an impact-responsive member mounted in said chamber adjacent one end thereof for movement along said longitudinal axis, said member including means for normally preventing movement of said cantilever spring firing pin and for releasing said cantilever spring firing pin upon impact with a target for movement toward said primer.
- 8. A fuze according to claim 7 wherein said impact-responsive member is an elongated rod, and said means for preventing movement of said cantilever spring firing pin comprises flange means formed on said rod and normally engaging said cantilever spring firing pin and movable from said engagement upon displacement of said rod along said longitudinal axis of said housing.
- 9. A fuze according to claim 8, and further including a rotor mounted in said housing adjacent the other end thereof for rotation by the centrifugal force developed by said spinning projectile from an unarmed to an armed position about an axis generally perpendicular to said longitudinal or spin axis,
 - a detonator mounted in said rotor to lie along said longitudinal axis in said armed position,
 - means providing communication between said primer and said detonator when said rotor is in said armed position,
 - said elongated rod being a firing pin for said detonator,
 - an integral shear flange on said rod, and
 - an arresting shoulder on said housing in the path of movement of said shear flange portion only of said rod, whereby movement of said rod beyond a predetermined point is normally prevented to thereby prevent direct detonation of said detonator by said rod, said shear flange being yieldable to an impact force of the degree encountered with an impenetrable target.

* * * * *