



# *A Multiple Capability Sympathetic Detonator System for the U.S. Special Forces*



*Presentation to the  
NDIA 2002 Mines, Demolition and  
Non-Lethal Conference and Exhibition*

*James J. Chopack  
U.S. Army Research Laboratory*



# ***Presentation Overview***



- **Program Background**
- **Operational Concepts and Requirements**
- **System Design Overview**
- **Developmental Field Tests & Type-Classification Tests**
- **Design Variants (underwater, surf)**
- **Program Schedule**



# Program Background



- **Program Manager:** PM - Mines, Countermine & Demolitions
- **User:** Special Operations Forces

**Program Objective:** Develop a system to **simultaneously** detonate numerous **unlinked** explosive charges through the command and control of only one.

## **Impact:**

- Small & Lightweight (fits in BDU pocket).
- Compatible with Demolition munitions & other equipment.
- Allows pre-assembled Demolition packages.
- Less time-on-target.

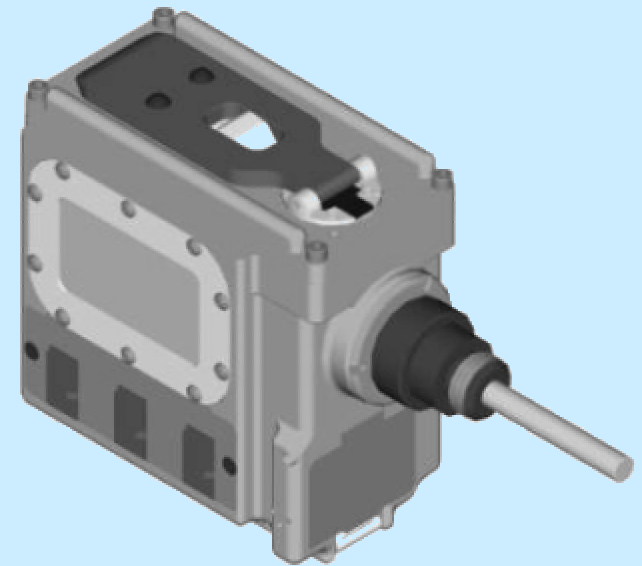



# *Development Roles*



## *ARL*

- electronics and micro-controller software
- acoustic sensor & algorithm
- mechanical housing, sub-assemblies and user interfaces
- engineering evaluation & assist DTC in Type Classification testing
- Technical Data Package

## *ARDEC & NSA*

- ESA & Firing Circuit

## *ARDEC*

- System Engineering, Logistics

## *Raytheon Technical Services Center*

- Electronic Layout, Type Classification & production hardware





# Technical Approach



## Two Modes of Detonation:

**Sympathetic** – SYDET detects nearby explosions (via **acoustic** sensor) and, if verified by on-board algorithms, will detonate its explosive.

**Time Delay** - At a **pre-set time**, SYDET will detonate its explosive.  
(Similar to M147 TDFD)

Countdown & Absolute Timers are used for pre-setting the acoustic listening window (SYDET) and the detonation time (Time Delay).



# Operational Concepts



In the **Sympathetic Mode**, SYDET Will Detonate Its charge upon the validation of a nearby explosion.

Multiple SYDETs can be placed on targets such that some will function simultaneously and others will function sequentially.

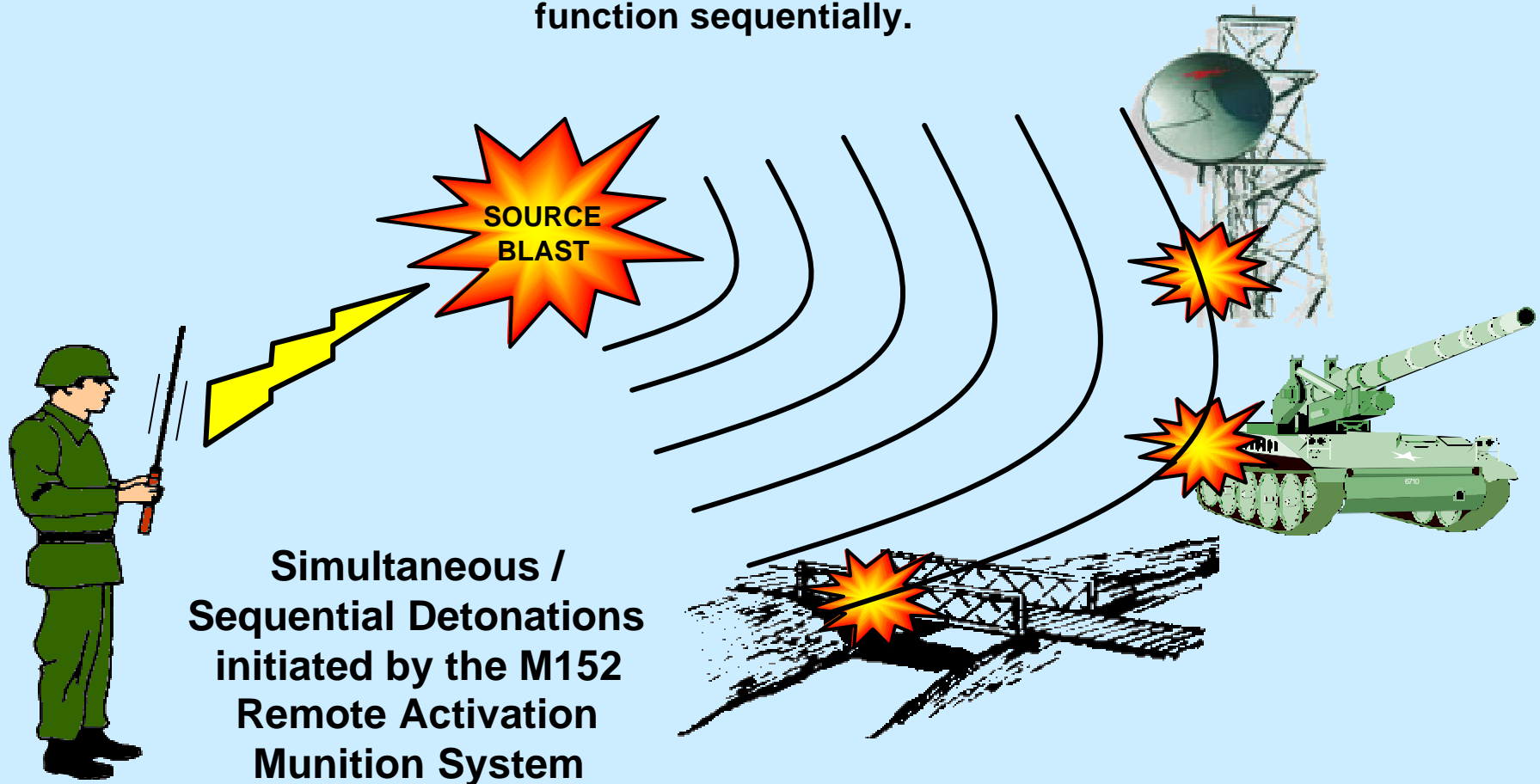



# Operational Concepts

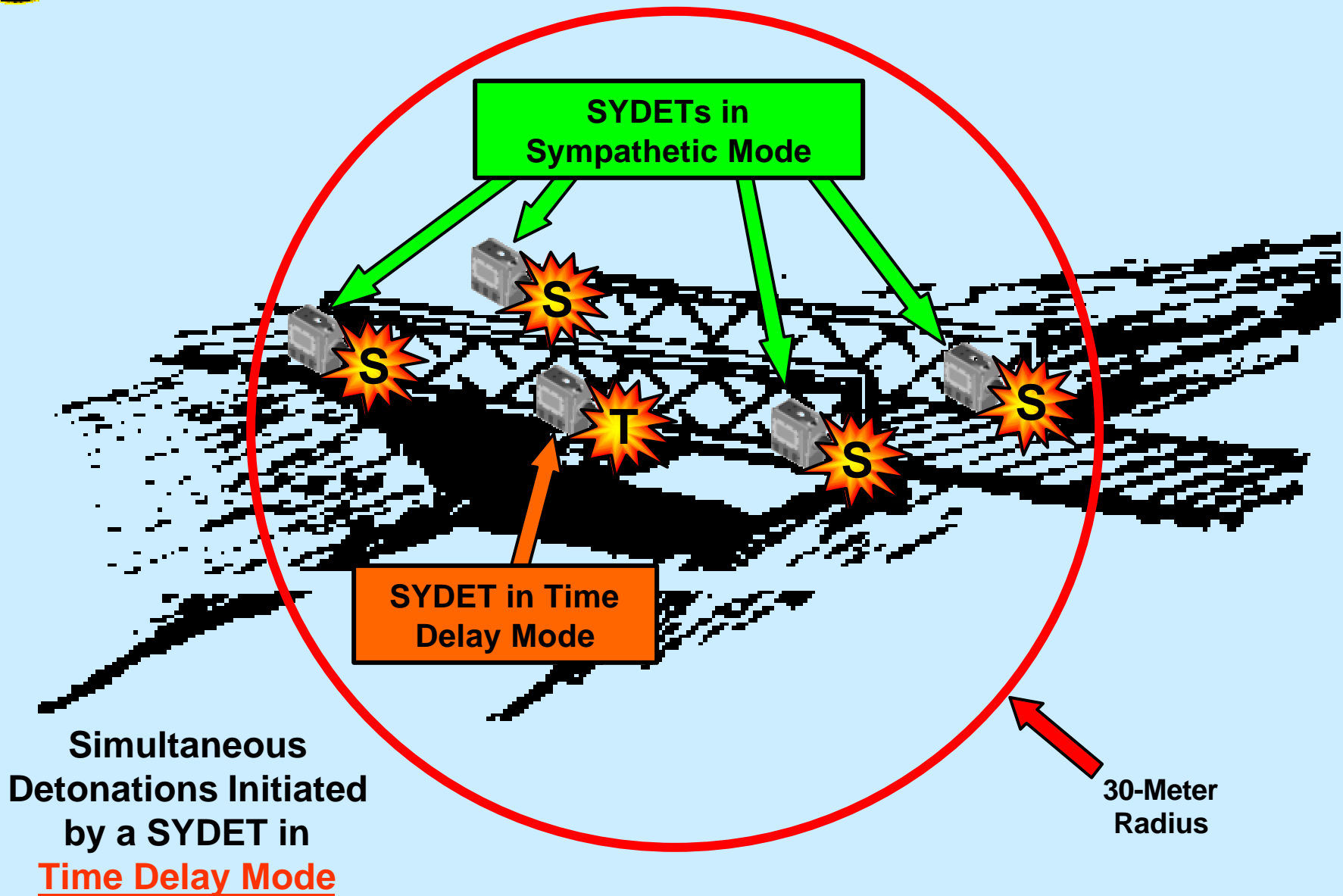



# Operational Modes



## Sympathetic Mode:

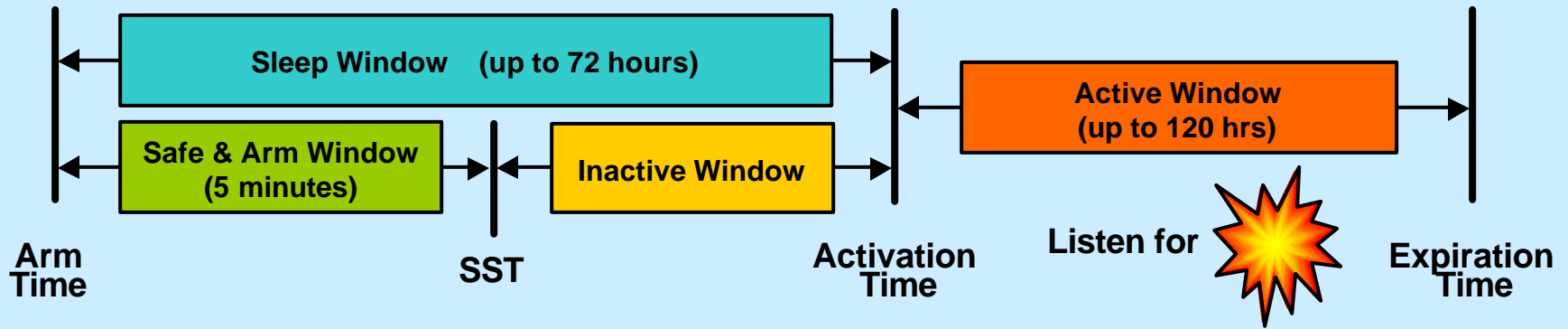

## Time Delay Mode:

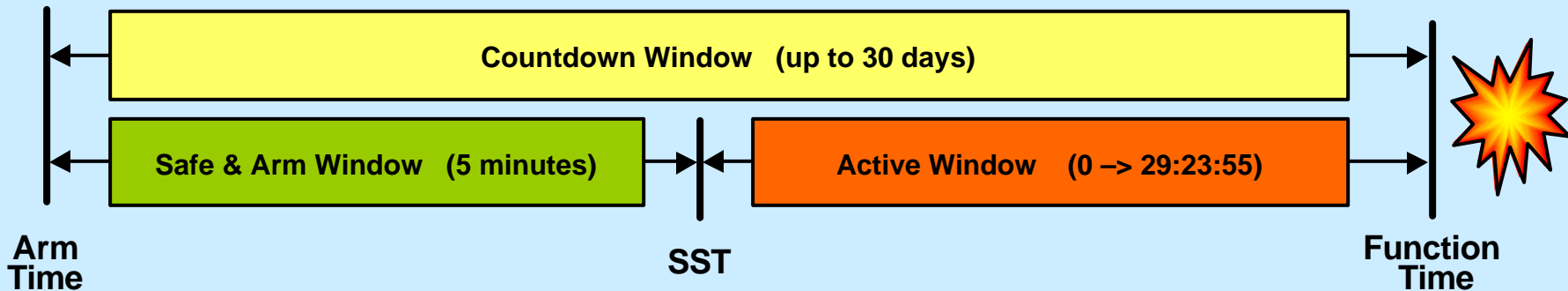



# ORD Requirements



## Sympathetic Mode:

- **Range:** 4-30 meters (Sympathetic Mode)
- **Stimuli:** C4 (1-5 Pounds), SLAM, or M18A1 Claymore
- **Response Time:** 0.5 Sec from Receipt of Stimulus (up to 12 seconds Cold, etc.)

## Time Delay Mode:

- **Functions:** Same as M147 TDFD plus Absolute Timer

## System:

- **Fire Train:** Same as RAMS M17 “B” Receiver
- **SST:** 5 minutes (same as RAMS)
- **Size/Weight:** 20 Inches<sup>3</sup>; 2 Pounds
- **Environmental:** Operational: -25 to +135 F; Storage: -25 to +140 F
- **Active Life:** Sympathetic: 48 Hrs; Time Delay: 30 Days
- **Transportation:** 35,000 Ft, 66 Ft Underwater, Cross Country, etc.



# Mechanical Assembly

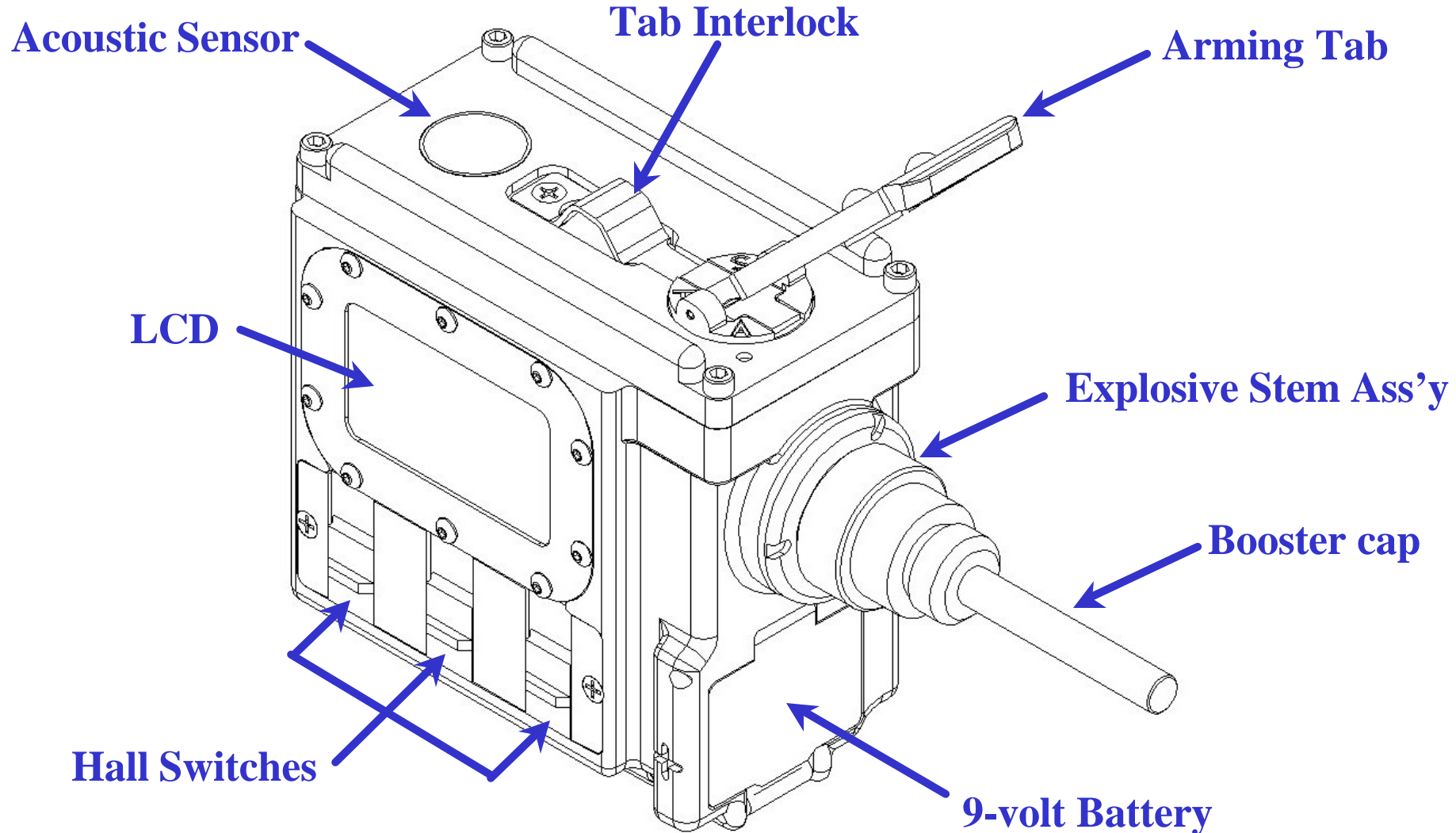



# Mechanical Assembly (exploded view)



## Circuit Boards (mounted on lid):

- Display / Acoustic
- Controller
- Fire

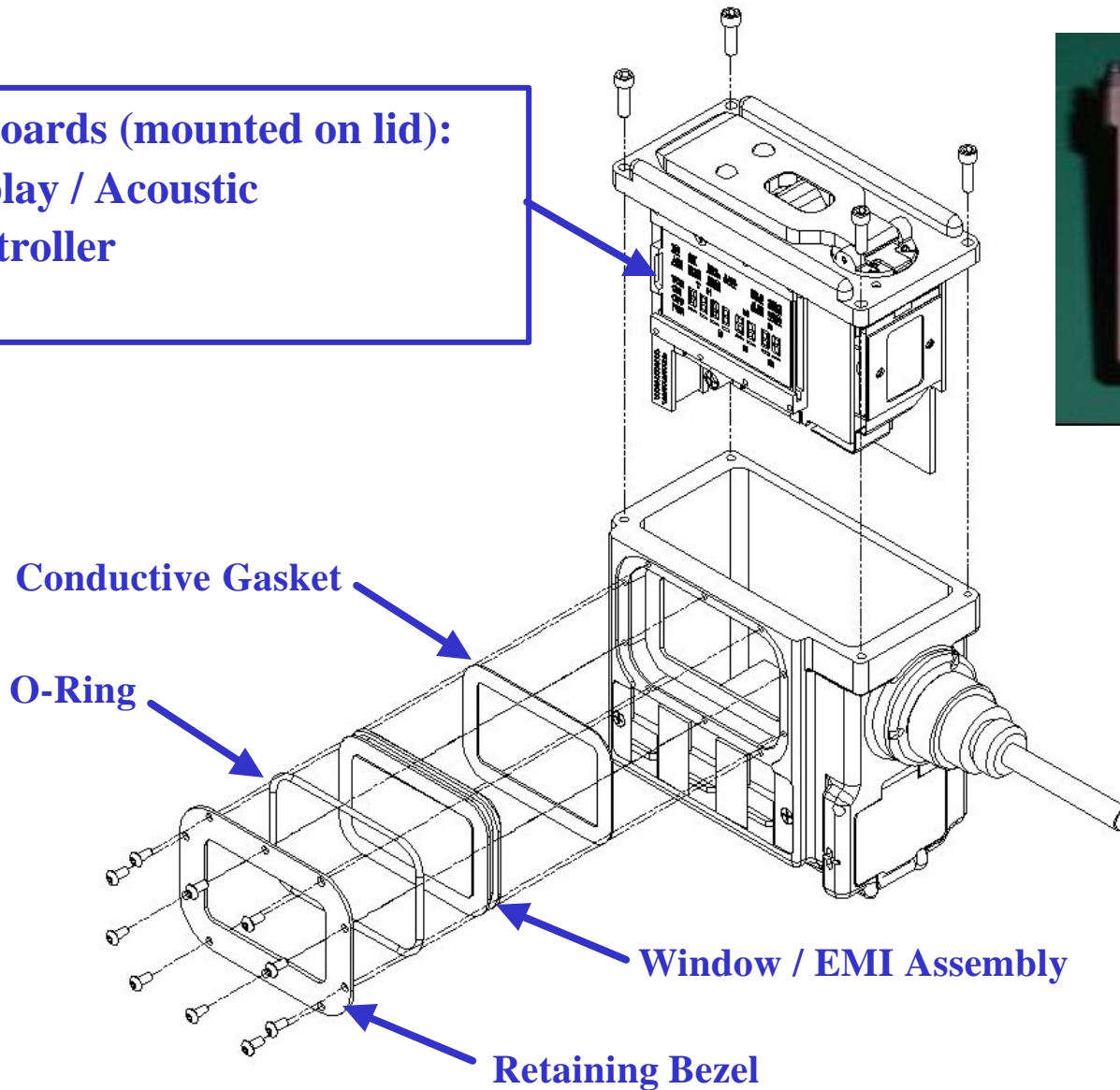





# Hall-Effect Switches



## Switch assembly employs:

- (1) internal low-power, ultra-sensitive, surface-mounted Hall Effect sensors that detect movement of
- (2) external high-energy, neodymium magnets mounted in sliders.

## Advantages over standard pushbuttons used on many military systems:

- (a) eliminates thru-holes and complicated seals.
- (b) requires far less space
- (c) simplifies assembly
- (c) decreases production costs

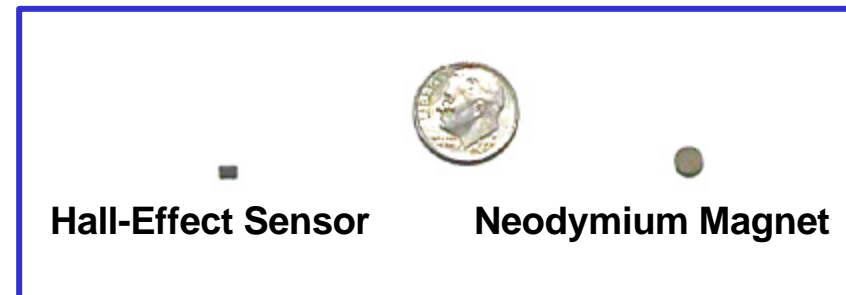
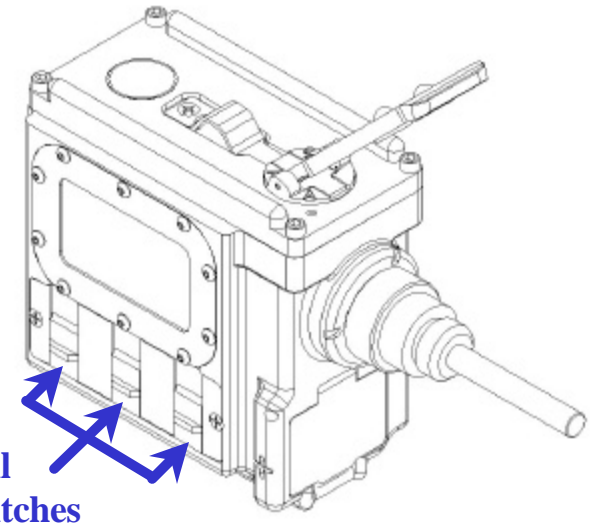





# System Block Diagram

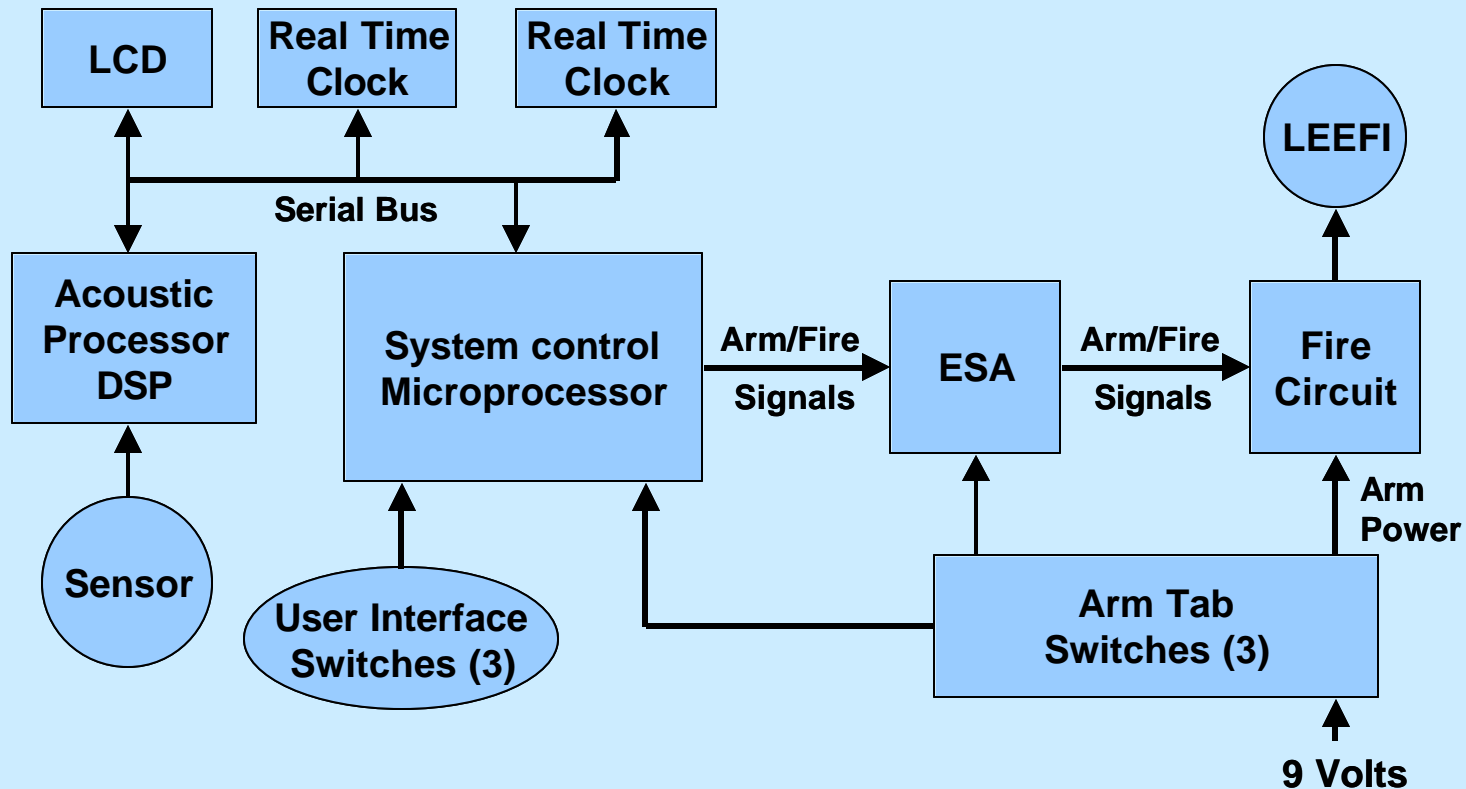

**Micro-Controller (Motorola 68HC705C8A):** Makes all major logic & control decisions.

- ( a ) Interfaces with the user (via arm tab, 3 slider switches, LCD display).
- ( b ) Recognizes, sets and controls the mode of operation.
- ( c ) Interfaces with the ESA circuit.
- ( d ) Monitors the DSP detection circuit.
- ( e ) Sets, monitors and verifies the redundant timer circuits.
- ( f ) Controls the fire circuit.



# Acoustic Sensor Assembly

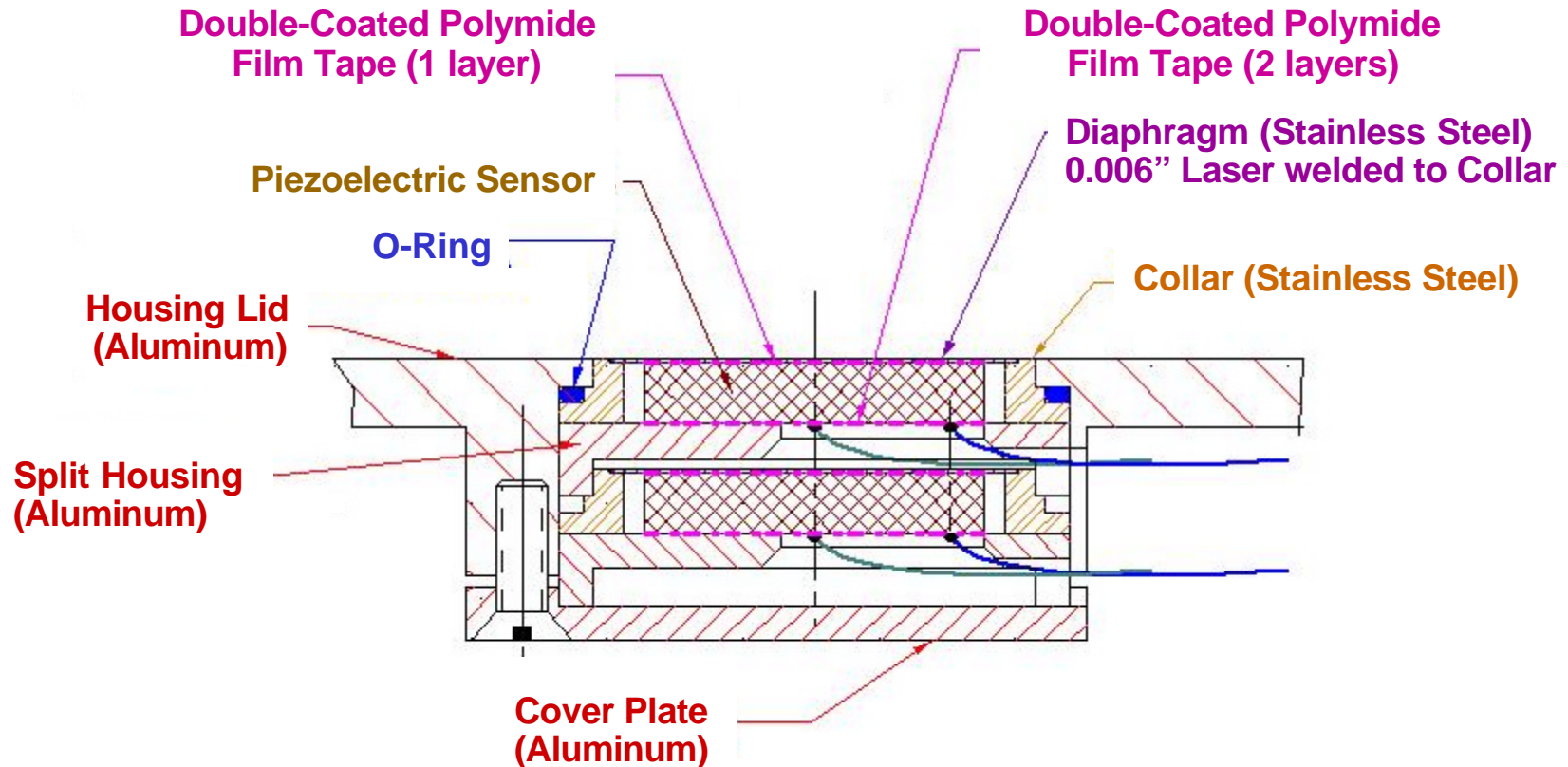

- **Double sensor** design reduces acceleration / vibration component of signal.
- **High pass filter (8 Hz)** reduces effects caused by air flow across & heating of sensor.
- **Low pass filter (200 Hz)** reduces the signature of many interfering sources.



# Acoustic Algorithm

## Setup

- Data is software low pass filtered at 110 Hz.
- Three 85 point circular buffers are maintained with filtered data, differences, and integrals.

## Steps to Trigger

1. Find a positive peak that has the required cumulative integral by the maximum time.
2. The data crosses the baseline in the required time with the required cumulative integral.
3. The data passes the baseline with the required cumulative integral in the required time. If the time limit is exceeded, an extrapolated value from the peak difference on the curve is used to find a shorter base line crossing and cumulative integral.

## Next Point

- A new point is added to the 85 point buffer and the steps are performed again.

## Boom

- If all the required values are reached.

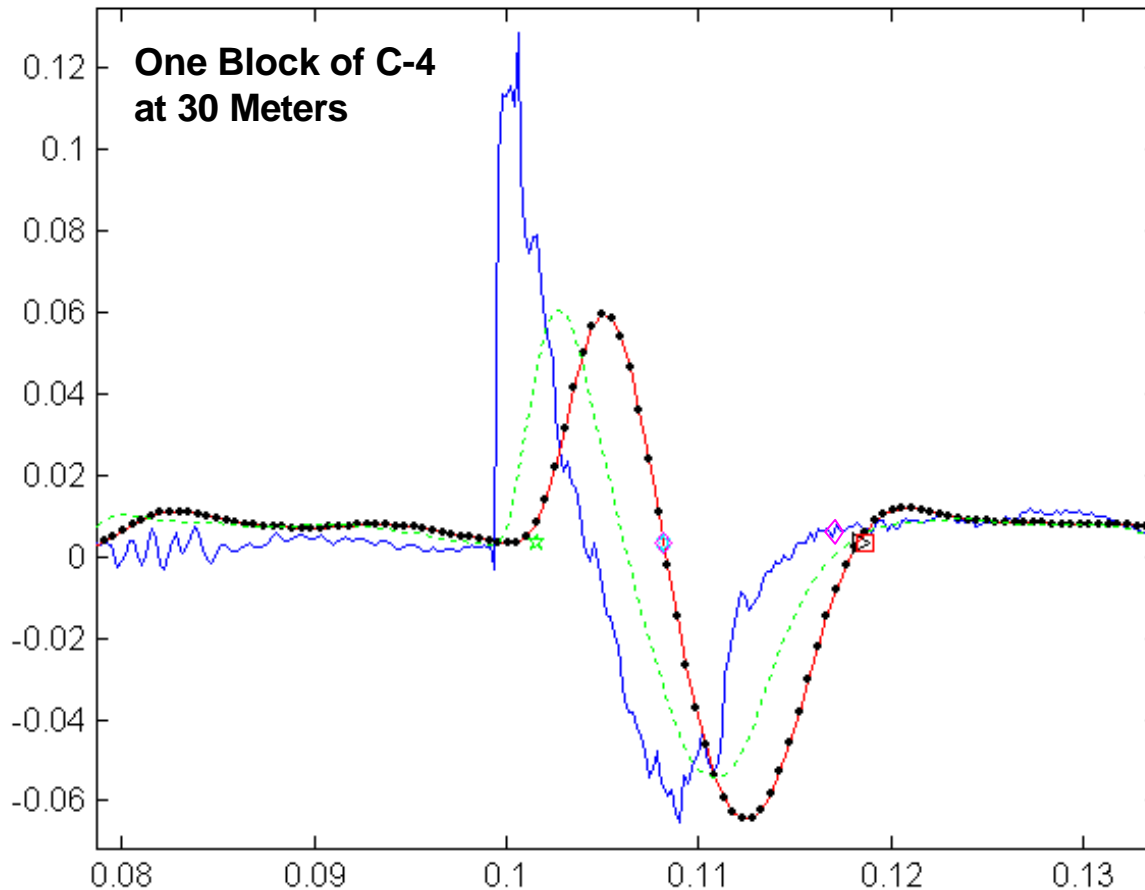

- Data samples at 2048 sps
  - ☆ First zero crossing interpolated from peak difference
  - ★ Second zero crossing interpolated from adjacent points
  - ◇ Last zero crossing extrapolated from peak difference
  - ▷ Last zero crossing interpolated from adjacent points
  - Trigger decision made
- } 25 samples, ~12 ms
- } 75 samples, ~37 ms



# Explosive Assembly

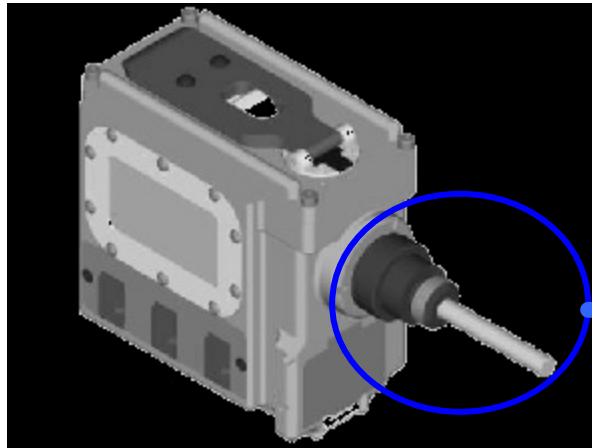

Booster Cap

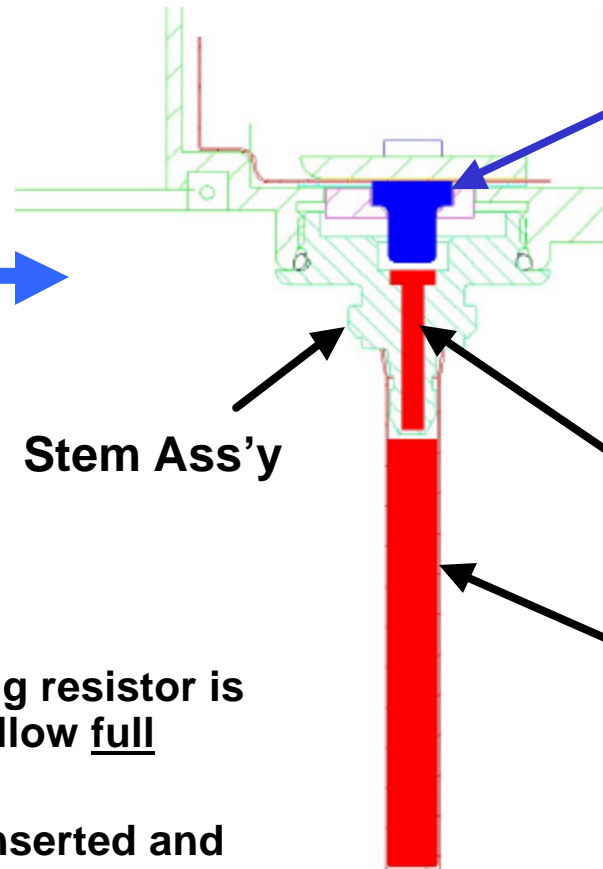

**LEEFI**  
(HNS-IV & PBXN-5)  
(sealed in housing)



**Transfer Charge**  
(PBX-9407)

**Booster Cap**  
(PBX-9407)  
(attached in field)

## Explosive Loading

- Prior to loading, a current viewing resistor is placed on LEEFI connection to allow full testing.
- Upon successful test, LEEFI is inserted and stem assembly is installed.
- Booster Cap is installed by soldier.
- Process is identical to that used on the M17 RAMS Receiver



# Field Tests



- 7 field tests in 3 environments conducted to date.
- Tested all ORD sources plus .50-cal, .45-cal, M24, M16 & grenade simulators.
- Database has over 5000 files (ORD sources + .50-cal)

<u>Environment</u>	<u>Location</u>	<u>Date</u>	<u>Objectives/Results</u>
Temperate	Blossom Point, MD	Nov 98 & May 00	Baseline measurements. Can distinguish among ORD sources & small arms fire using acoustic sensors only.
Winter	Ft. Greely, AK Camp Ripley, MN	Feb 99 Mar 02	Ground conditions (snow or no snow) affect acoustic waves.
Urban	Blossom Point, MD Aberdeen, MD Ft. Benning, GA	May 00 Jun 01 Nov 02	LOS & NLOS MOUT. Streets & Walls. Explosives on walls. Diffractions change waveforms MOUT LOS higher amplitude.
Jungle	Eglin, AFB	Aug 02	Scattering & absorption of sound due to dense vegetation.



# System Integration Test Plan Matrix



TEST	DT/OT II TEST NO.	PKG	BARE	REQUIREMENT	MIL-STD/ SOURCE DOCUMENT
<b>ENVIRONMENTAL (Operational Check Will be Performed After Each Test Exposure)</b>					
Operating Temperature	301		X	Operable	MIL-STD-810
Fungus	302		X	Operable	MIL-STD-810
Solar Radiation	303		X	Operable	MIL-STD-810
Humidity	304		X	Operable	MIL-STD-810
Salt/Fog	305		X	Operable	MIL-STD-810
Icing/Freezing Rain	306		X	Operable	MIL-STD-810
Immersion (66')	307		X	Safe & Operable	ORD 29 March 97
Low Pressure	308		X	Operable	MIL-STD-810
Sand/Dust	309		X	Operable	MIL-STD-810
<b>SAFETY</b>					
Transit Drop 4 Ft.	320		X	Safe & Operable	ITOP4-2-602
5 Ft. Drop	321		X	Safe	ITOP4-2-602
7 Ft. Drop	322	X		Safe & Operable	ITOP4-2-602
Secured Cargo Vibration	323	X		Safe & Operable	ITOP4-2-601
Loose Cargo Vibration	324	X		Safe & Operable	ITOP4-2-602
Thermal Shock	325		X	Safe & Operable	MIL-STD-331
Shipboard Shock	326		X	Safe & Operable	MIL-S-901D, Grade A, Class I, Type A
40 Ft. Drop	327		X	Safe	MIL-STD-331, Test C7
Jolt/Jumble	328		X	Safe	MIL-STD-331
Out-Gassing	329		X	No Hazard	NAVSEA S9510-AB-ATM-010



# System Integration Test Plan Matrix

(continued)

TEST	DT/OT II TEST NO.	PKG	BARE	REQUIREMENT	MIL-STD/ SOURCE DOCUMENT
<b>ELECTROMAGNETIC ENVIRONMENT EFFECTS</b>					
EMI	330		x	Operable & Compatible	MIL-STD-461
PESD	331		x	Safe & Operable	MIL-STD-331
HESD	332	x		Safe & Operable	MIL-STD-331
Near Lightning Effects	333	x		Operable	MIL-STD-464
EMRO	334		x	Operable	ITOP 1-2-511
HERO	335	x	x	Safe	MIL-STD-464
HEMP	336	x		Safe & Operable	MIL-STD-461
<b>OTHER</b>					
90 Day Cache Tropic	350	x	x	Operable	
NBC Contamination	351	x		Operable	ORD 29 March 97



# Underwater Variant



## Coastal Systems Station, Panama City

### Technical Similarities

- Technical Approach
- Outer Housing
- Arming Tab
- Modes of Operation
- Firmware
- ESA / ASIC
- Explosive Train

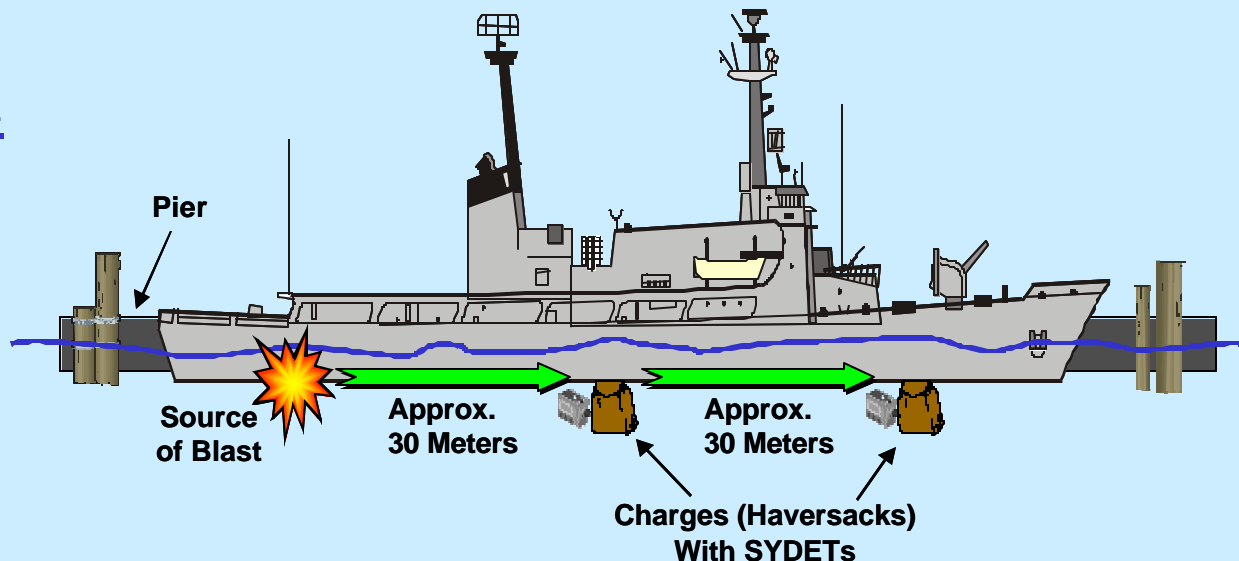

### Technical Differences

- Safe Separation Time
  - proposed 30 minutes vs. 5 minutes to allow safe egress of swimmers.
  - accomplished via crystal change
- Possible Increased Unit Hardening
  - to withstand greater underwater shock
  - potting or glass beads may be used

EVENTS	FY01	FY02	FY03	FY04	FY05	FY06
DATA COLLECTION AND ANALYSIS	██████████					
MILESTONES			B ▲	C ▲		
DT&E		DT&E	DT&E		TEC/VAL/OPEVAL	
DESIGN REVIEWS			▲ PDR	▲ CDR		
HARDWARE PRODUCTION/ DELIVERIES			EDM		██████████ →	





# Program Schedule

