

THE CONSTRUCTION OF CROSS BOWS & OTHER WEAPONS



THE CONSTRUCTION OF CROSS BOWS & OTHER WEAPONS

Copyright (c) 2000 Harold Hoffman

We have many good Mini and other books on Gunsmithing, Knife making, History, Out of date, and Crafts books. The purpose is to give you the basic information on subject that is covered here. I hope you enjoy and learn from these books. H. Hoffman

All rights reserved. No parts of this publication may be reproduced or transmitted in any form or by any means, electronic or mechanical, including photocopy, recording, or any information storage and retrieval system, without the written consent of the publisher.

Action Books
7174 Hoffman Rd.
San Angelo, TX. 76905
Phone 325-655-5953
[Home site](#)

Zaibatsu Release

I am the alpha, the omega,
the beginning¹ and the end

THE CONSTRUCTION OF CROSS BOWS & OTHER WEAPONS



ABOUT THE AUTHOR

Harold Hoffman has through his 30 plus years of experience as a Gunsmith, Toolmaker and Custom Knife maker has passed on to you through his books information that soon may be lost or forgotten. His books are not intended for the person wanting to make a complete firearm, but for learning basic shop tool making. The information found within his books is for instructional purpose only. -- The titles DO NOT actual cover gun repair on firearms, but how to make needed parts for firearms which is about 40% of all gun repair. Without this information you will be severely limited in gun repair.

He first started gun repair when he was 18 years old doing minor repair for the farmers and local hunters in the Bucklin, Kansas area. His main interest was how to make rifle barrels, as he was an avid hunter. Moving into a bigger shop he bought a lathe and proceeded to learn how to use it.

He wanted to find out how to make rifling buttons to rifle barrels, tool making, and learn everything about making barrels. Over the years he became an expert toolmaker and how to build most everything that was needed in the shop. The information found in his books will show you how to make most of the equipment and tools needed in most shops.

After an eye accident he quit Gunsmithing and started writing books on everything that he knew. He had so much difficulty finding any information that he wanted all this information that he had learned in over 30 years to be available to everyone otherwise it would be lost.

His books are now about the only books available on Gunsmithing/Tool making, as most publishers do not publish Gun or Gunsmithing books anymore.

THE CONSTRUCTION OF CROSS BOWS & OTHER WEAPONS

CROSSBOWS

The following is a general summary of the crossbow stock, parts and how we construct it. In the following chapters, we will go into much more detail on its construction, and will describe several different types of crossbows that you can build.

You can make the stock of your crossbow in whatever style you prefer. For good shooting, we must adapt the gunstock to the individual, and you will find that a stock made to your measurements will enable you to shoot far more accurately.

What to look for in good weapon design is;

1. Balance, which we can achieve only by trial and error.
2. Simplicity of line, which means ridding the surface of every irregular knob, joints, levers, and unsightly angles.
3. Accuracy in shooting, which we can change by the kind of stock used, the groove the bolt runs in, the angle at which we attach the prod to the stock, and the size, weights and fletching of the bolts.

When you build a crossbow, the most important consideration is to have a perfectly straight groove along which the bolt will travel. Any curve or irregularity in this groove will cause inaccuracy because the bolt will be traveling at up to 200 mph and will hit any curve with great force and deflect the arrow. Friction will reduce the range of the bolt, so besides being straight, the groove must also be smooth and polished. The depth and width of the groove will govern the type of bolt and the height of the fletching that we use on the arrow.

You can adapt the designs shown in other chapters to your length of arm and face contour. You will see that the comb of some stock is comparatively flat, but you can raise or lower it before you cut out the wood. Lay out the pattern on a cardboard blank to check on the way the design will fit your face and arms. From this, you can make whatever adjustments are necessary for your comfort and ease of both holding and aiming.

If the stock is wood, the best way of ensuring that it stays straight is to make it of three laminations from hardwood.

You must start with a good base for the weapon by using only well-seasoned and laminated wood.

You also can use three, 3/8 hardwood boards that you laminate together. If a band saw is not available, then you can easily shape the 3/8-inch boards with a coping or saber saw before you glue it together. You can leave the centerboard blank and form the opening for the trigger

THE CONSTRUCTION OF CROSS BOWS & OTHER WEAPONS

mechanism and the bolt groove if the centerboard is not too wide.

Also, you can also use several pieces of wood veneer glued together to get the thickness needed in the trigger, lock, and the arrow groove. By careful cutting and fitting, you can shape all of the interior shapes, thus eliminating much handwork.

The shape of the butt also needs careful consideration. When using a crossbow, you need a much higher trajectory at 100 yards for crossbows, so you can slide the butt much farther down the shoulder to achieve the required elevation when aiming at the longer distance. This means that the crossbow butt must have a long and shallow curve compared with the short, deep curve of the rifle butt.

To keep from hurting your fingers when they get in the way of the string is a major concern for all crossbow users. The best way to guard against such an accident is to make the stock at least 3-15/16 inches deep at the point where the supporting hand will be holding it. A long deep groove, in which the fingers can get a grip, will reduce the likelihood of any such accident.

If you are going to use a solid piece of wood for the stock, it must be a hard wood. You cut it from a plank that will be roughly 35 inches long 8 inch deep 1-1/2 inches thick. Any good hard wood will do, but you need to choose the wood in which the grain is not coarse. Walnut makes an ideal stock, and so does maple. However, you need to find a well-seasoned piece so that it does not warp after getting the stock finished.

From the pattern that you made trace the final pattern on the blank and then cut it out with a band or a saber saw. Be sure that the top of the barrel is absolutely straight and level. Rounds off the edges and corners with a wood rasp, and finish with sandpaper.

When you cut out your stock, you will be ready to cut the trigger and latch position, which is done from the top of the barrel. If you have laminated the stock from thin wood, you can already have this completed after gluing. I show several different types of triggers and locks in a separate chapter. You can adapt most of these triggers and locks to any type of stock that you want to build. When you get ready to mark out where the trigger and lock will be, measure forward 14 inches from the butt of the stock and center down the barrel. This will be the after edge of the latch inlet. You remove this material with a chisel. When completed, smooth it with sandpaper so no roughness will interfere with the smooth action of the trigger and the latch, once we have inserted them.

If you use a solid piece of lumber for your stock, the next step is to cut the bolt groove, which runs forward from the latch inlet to the end of the barrel. With the rough groove cut, sand the sides and bottom to a good finish.

To do this, take an arrow dowel and wrap it with fine sandpaper. Using this sanding dowel,

THE CONSTRUCTION OF CROSS BOWS & OTHER WEAPONS

work back and forth along the groove until you have a 1/16-inch chamfer made, along which the arrow will travel. Your bolt, if you have fletched it, will travel down this chamfered groove, with the cock feather riding in the bottom of the groove.

Friction, acting against the bolt, will not only act to impede its flight but may make for trifling inaccuracies that will multiply when it comes to actual shooting.

They normally call bows used for crossbow prods. There are five types of prods used for crossbows.

1. Wood bows, was widely used for crossbows and make an excellent bow. The main drawback of wood bows is that they are usually long. This is no problem when target shooting, but is a handicap when in the brush.
2. Steel bows have been around for a long time, and is still use today for hunting. The main drawback of steel bows is they have a hard jar when fired, and over time they may shatter. Shooters who use steel bows usually wrap the bow with tape to prevent injury in case the bow breaks.
3. Solid fiber glass bows are a good choice for target and hunting bows. They are Relative low in cost, easily altered, and are very dependable. You can shorten and use standard bows used by archers for the crossbow prod.
4. Compound bows are the new trend today. With these bows, you can get maximum velocity from your arrow or bolt. They are smooth to shoot and are fairly trouble-free, however, they usually require a different type of stock than we show here.

Crossbow bolts are just archery arrows shortened for use in a crossbow. Usually, bolts used for hunting are shorter and heavier than target arrows. Normally, you make them from wood dowels, but many hunters are now using fiberglass arrows.

This is a very short brief of crossbows, but it will give the reader information on the construction of crossbows and related items, which can be found below.

THE CONSTRUCTION OF CROSS BOWS & OTHER WEAPONS

MAKING A TARGET/HUNTING STOCK

This type of crossbow stock that I describe in this chapter is an all-purpose crossbow and can be used for hunting for target shooting. You make the arrows or bolts used for this crossbow from a 5/16 dowel that is 23-1/2 inches long. If you plan to use it for hunting and target shooting, I would recommend using the type of pile or point that will unscrew and then you can switch from target points to broad heads, or vice versa.

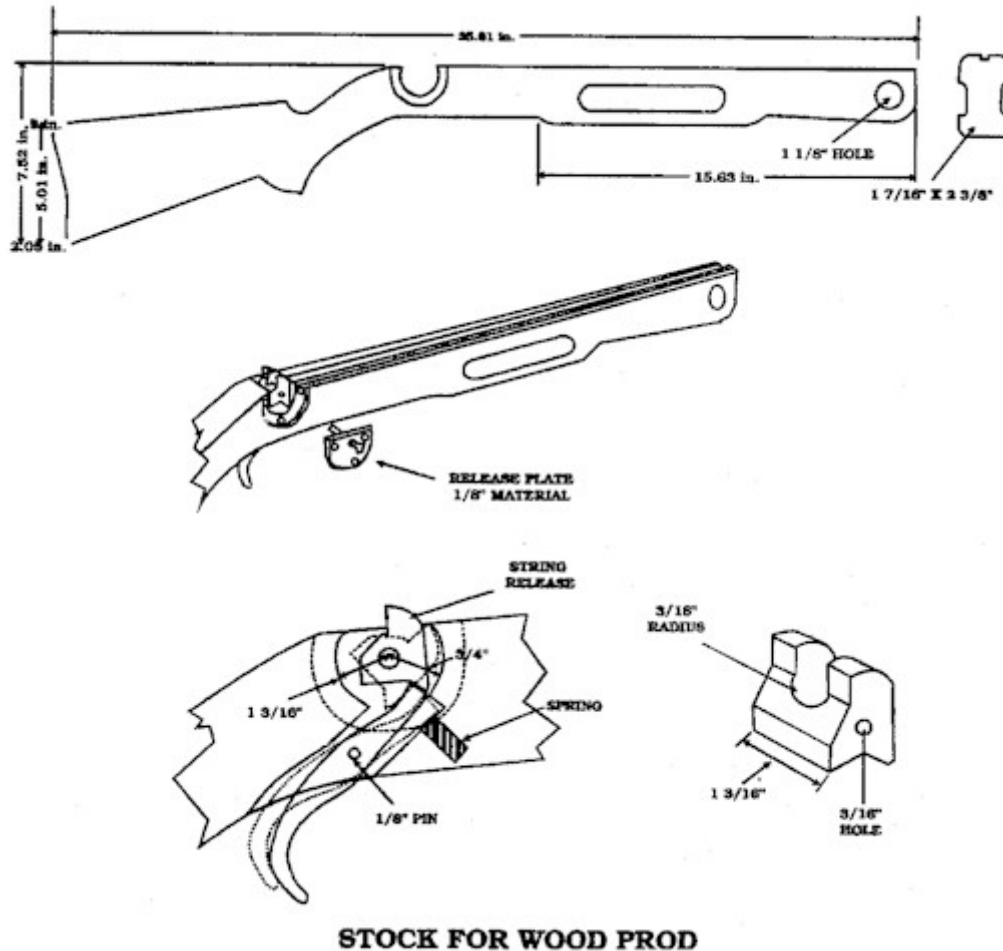

STOCK FOR WOOD PROD

The stock of your crossbow comes in many shapes and sizes; you can make it in whatever style you choose. For good shooting, we must adapt the lines of the gunstock to the individual, and you will find that a stock made to your measurements will enable you to shoot far more accurately.

The raw material for the stock is hard wood of some sort, cut from a plank that will be roughly 35 inches long, 8 inches deep, by 1-1/2 inch. Any good hard wood will do, but choose one in which the grain is not coarse. Walnut makes an ideal stock, and so does maple, if you can find a well-seasoned piece.

If the stock is wood, the best way of ensuring that it stays straight is to make it of two or three

THE CONSTRUCTION OF CROSS BOWS & OTHER WEAPONS

boards laminated from hardwood, and use only well seasoned wood.

You also can use three-3/8 inch boards that you glue together. If a band saw is not available, then you can easily shape the 3/8-inch boards with a coping or saber saw before you glue them together. You can also use several layers of veneer to make your stock from and then you can form the opening for the trigger mechanism and the bolt groove. This will save you quite a bit of time, as you will not have to chisel out the opening for the trigger and lock. By using veneer, you can shorten the centerboard. The arrow groove will then be completed, sanding and finishing. (See the chapter on laminating wood)

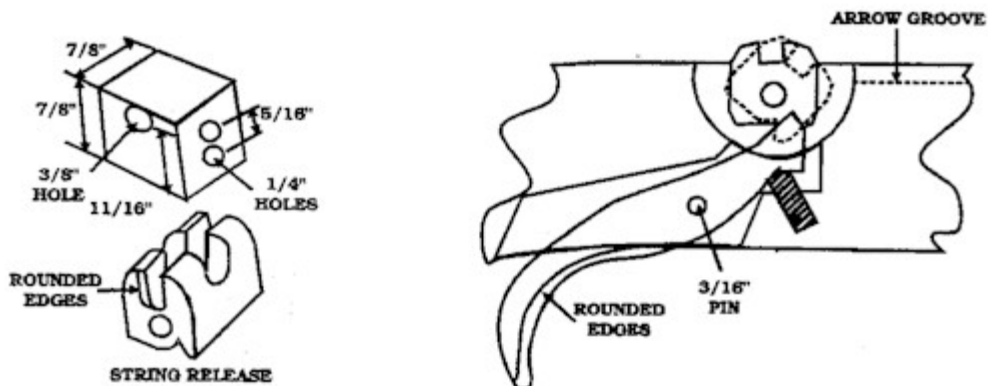
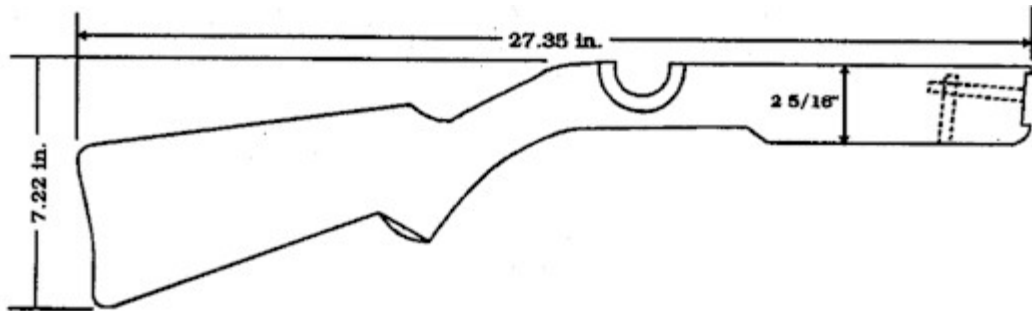

STOCK FOR METAL CROSSBOW

The shape of the butt also needs careful consideration. When using a crossbow, we need a much higher trajectory at 100 yards. You can slide the butt much farther down the shoulder to achieve the required elevation when aiming at the longer distance.

First, you will need to draw the stock pattern on a piece of heavy cardboard, then transfer the stock outlines to the wood plank for veneer. For the average Craftsmen, cutting out a stock from a solid piece of wood may prove difficult, so I recommend that you use veneer or thinner

THE CONSTRUCTION OF CROSS BOWS & OTHER WEAPONS

boards and laminate them together.

After you have cut out the stock, and laminated it, you will need to make the trigger and release or lock. In the drawing, I show one type of trigger and release, but you can use any type you choose. Look over all the different type of triggers and releases in the chapter on locks. By scaling you can use any of these triggers to fit the stock that you are using.

When your stock is finished, you will be ready to cut the trigger and latch position, which is done from the top of the barrel. Measure forward 14 inches from the butt of the stock and center down the barrel.

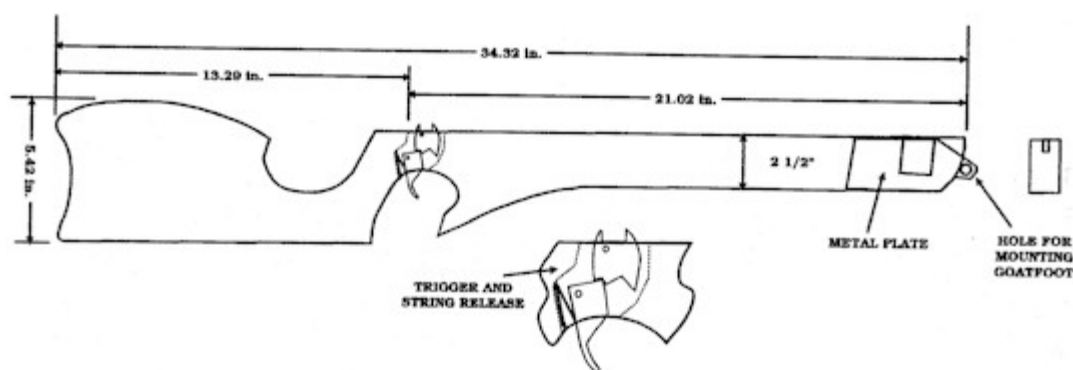

TARGET CROSSBOW

When you fit the trigger and release, you make a pattern of the trigger and release on a thin piece of cardboard. Next, lay the stock on your workbench and lay the trigger and release on the side of the stock where you will mount them. Get to heavy pins and press them through the cardboard where you will drill the pins. Line up the trigger and release in the correct position and press the pins into the wood. By doing this, you can check to see if the trigger and release are in the correct position and will function correctly. You can rotate both on the pins and you can move them slightly until they are placed right.

Before you make the stock, especially if you laminate it, you need to decide the type of release and trigger that you will be using. Usually the release will be thicker than the trigger so you should consider this when you glue up the stock. By doing this, when we glue up and complete the stock the trigger and release should drop into the space that you made for it in the stock.

If you make the stock from solid wood, take out the material with chisels. When done, smooth with sandpaper so no roughness will interfere with the smooth action of the trigger and the latch, once we have inserted them. You then inlet the stock with chisels so it emerges in the center of the trigger guard. It should be exactly 9/16 inch wide, 9/32 inch on either side of the barrel centerline.

When you have both the trigger and release set where you want them, then you can drill the holes. You will drill the hole for the release with a 3/16-inch drill and you drill the trigger

THE CONSTRUCTION OF CROSS BOWS & OTHER WEAPONS

pinhole with a 1/8-inch drill.



Your next step is to cut the bolt groove, which runs forward from the latch inlet to the end of the barrel. On either side of dead center, mark out a line $\frac{3}{32}$ -inch, so that your groove markings cover a spread of $\frac{3}{16}$ inch along the barrel. Take out the material between your two lines to a depth of $\frac{1}{2}$ inch, if you have a table saw, you can cut the bolt groove with it. It is very important that this groove is completely straight, as any irregularity will cause the arrow to shoot off.

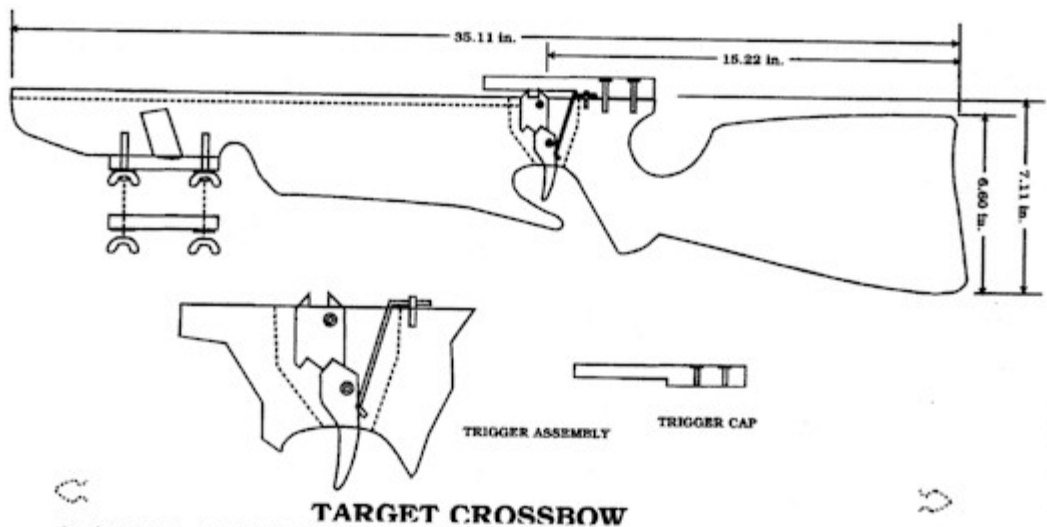

When you have the rough groove cut, sand the sides and bottom to a good finish. To smooth the groove, take an arrow dowel and wrap it with fine sandpaper. Using this sanding dowel, work back and forth along the groove until you have a $\frac{1}{16}$ -inch chamfer made, along which the arrow will travel.

If you have laminated the stock, and after all the glue has set up, all the edges except the bolt groove must be rounded with a rasp or coarse file. Leave the area on the stock where the trigger and release go flat for now.

THE CONSTRUCTION OF CROSS BOWS & OTHER WEAPONS

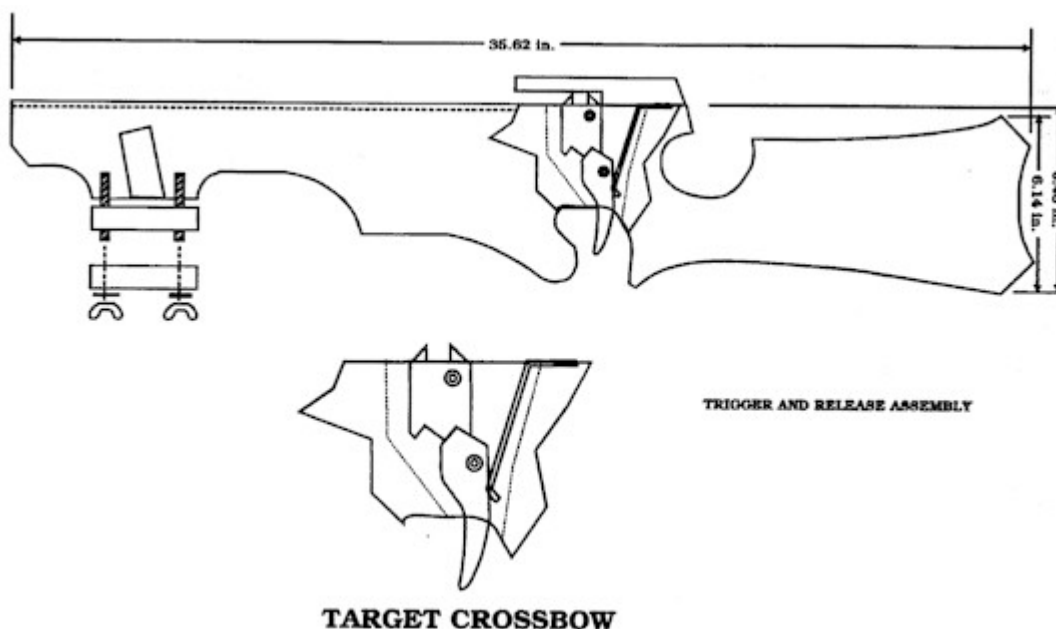

The top of this bolt groove must be absolutely flat and smooth. Then, you screw strips of Formica or thin brass on top to give a long straight gap of 3/16-inch width. This can be slightly wider if you are using heavier bolts, and you should position them down the dead center of the stock. The smoothness of Formica makes a good surface on which the bolt and string can ride, but brass will last longer.

Any sharp edges should be rounded, and the entire surface of the stock should now be fine sanded and painted with a clear wood filler or sealer. When the filler is hard, sand it again, and then apply two or three coats of clear polyurethane varnish.

When you build this crossbow, you must have a perfectly straight groove along which the bolt will travel. Any curve or irregularity in this groove will cause inaccuracy because the bolt will be traveling at up to 200 mph and will hit any curve with a great force and deflect the bolt.

Also, friction will reduce the range of the bolt, so besides being straight, the groove must also be smooth and polished. Be sure that the top of the barrel is absolutely straight and level. Rounds off the edges and corners with a wood rasp, and finish with sandpaper. The depth and width of the groove will govern the type of bolt and the height of the fletching to be used.

Your bolt, if you have fletched it, will travel down this chamfered groove, with the cock feather riding in the bottom of the groove. Make sure that the finish of the wood is as smooth as possible.

Protecting Your Fingers

Hurting your fingers when they get in the way of the string is a major concern to most crossbow shooters. To guard against such an accident, make the stock at least 3-15/16

THE CONSTRUCTION OF CROSS BOWS & OTHER WEAPONS

inches deep at the point where your hand will be grasping it. A long deep groove, in which the fingers can get a grip, will reduce the chance of any such accident.

Cover Plates

These are plates that hold the trigger latch pins in place. There is another pair to hold the prod in position in the stock. You usually make them of 1/8-inch aluminum or brass plate and fastened to the stock with metal screws. The basic sizes will be apparent. The actual size and shapes will be up to you, as you can cut these to any fancy shape. I like to use aluminum or brass for these side plates due to the strength that it adds to the crossbow. If you like, you can make these cover plates from wood to give additional contrast to the finished crossbows.

You should cut the two pieces according to the drawings. You can make the patterns from the drawings and get them enlarged to the correct size at a copy shop.

Making The Trigger

After you cut out the trigger, it will need to be finished. The trigger requires a better finish than does the actual latch. Drill the two holes, which will hold the pivoting pins with care and the corresponding holes drilled into the stock with equal precision. The pins should either be 1/8 inch for the trigger, and 3/16-inch diameter for the release. They move freely when placed within the stock. You can make the spring from some type of small-coiled spring.

Adjust the spring to keep your pull easy, and when properly done, the trigger release should be as smooth as that of a good rifle. After finishing the trigger and release, assemble in the stock and check for smoothness. If there is any roughness, polish the release or trigger until their action is smooth and not sticky.

When the trigger and release are completed, they can be set into the stock. Next, mount the cover plates with fine brass wood screws that are countersunk into the cover plates. This way, if at some future date, you need to remove the trigger for release, you can remove the cover plates and correct the trouble.

The cover for the latch is optional, what it does is to keep the string from coming off the release by accident. You must carefully make the trigger cover to exact dimensions to prevent the string from jumping over the catch before we have released it. You can also mount a flat spring to this cover for holding the bolt in place. I also use this cover for mounting the rear sight. When you make the cover for your latch, keep in mind that it must be high enough over your barrel to allow the bolt or arrow to fit underneath it.

You make it as a single piece, and then we glue or fasten it in place with a couple of wood screws immediately behind the latch position.

Next, you slot the fore piece of the barrel to hold the prod. Now, decide the size and shape of

THE CONSTRUCTION OF CROSS BOWS & OTHER WEAPONS

this slot by what type of prod or bow you are going to use. You should cut the slot so when you lock the prod into position its top is 1/2 inch below the barrel.

The actual position of the slot and its angle is in relation to the length of the barrel is governed by the draw length of the prod.

You will need to know the dimensions of the handle or center proportion of the bow before you cut this slot. The depth of your prod governs the actual width of the slot so do not make the actual cut until the prod is completed. The prod when in place, should fit snugly but without any binding.

You must cut the slot at a slight angle, rather than square to the stock. If you cut the slot square, the bowstring, on release, would travel forward along the barrel, creating an incredible amount of friction and wear on the string. I cutting the slot on an angle, we reduce the frictional wear.

Cover Plate

Make the cover plates to screw into the sides of the barrel of the stock, above the prod lock cover. The cover plate that holds the prod in place should be the width of the barrel. They should be about five inches long and 1/4 inch thick if made from brass or aluminum, and fastened to the stock by wood screws.

The lower lock plate that holds the prod in place should be about four inches long by 3/4 inch thick. You can make it from hard wood, plastic, or Formica. I used two-threaded lag screws to screw into the stock; these are 1/4 inch by four inches long. They have wood threads on one-end and standard 1/4-inch threads on the other in. Use 1/4-inch wing nuts with a washer to hold the plate in place. The nuts will give you sufficient pressure to hold the prod firm. These cover plates serve to cover the wedge and your design will determine the shape.

Prod Or Bow Slot

You make the bolt-holding spring from a thin flat spring, and you shape it like a wide-open AV. You can drill and mount the catch to the latch. This will hold the bolt down in the groove.

A Prod up to 80 lb. or 90-lb. pull on the prod can usually be cocked by hand, but a stirrup against which to pull the string when cocking will make it easier to cock. When the pull exceeds 100 pounds, a cocking lever or a goats foot is use to cock the bow.

You rasped the stock down to shape and then finished with rough to fine sandpaper. Be sure the stock is finished smooth as possible, using sandpaper. The finish of the stock itself should be a good polyurethane varnish. (See the chapter on finishing). When completely dry, rub on a good grade of silicone wax that will protect the stock against weathering.

The stock of your crossbow comes in many shapes and sizes and can be made in whatever

THE CONSTRUCTION OF CROSS BOWS & OTHER WEAPONS

style you like. For good shooting the lines we must adapt the gun stock to the individual, and you will find that a stock made to your measurements will enable you to shoot far more accurately.

1. Balance which we can achieve only by trial and error.
2. Simplicity of line, which means ridding the surface of every irregular knob, joints, levers, and unsightly angles.
3. Accuracy in shooting, which we can change by the kind of stock used, the groove the bolt runs in, the angle at which we attach the prod to the stock, and the size, weights and fletching of the bolts.

When you build a crossbow, the most important consideration is to have a perfectly straight groove along which the bolt will travel. Any curve or irregularity in this groove will cause inaccuracy because the bolt will be traveling at up to 200 mph and will hit any curve with great force and be deflected. Friction will reduce the range of the bolt, so besides being straight, the groove must also be smooth and polished. The depth and width of the groove will govern the type of bolt and the height of the fletching to be used.

You can adapt the designs shown in other chapters to your length of arm and face contour. You will see that the comb of some stock is comparatively flat, but you can raise or lower it before you actually cut out the wood. Lay out the pattern on a cardboard blank to check on the way the design will fit your face and arms. From this, you can make whatever adjustments are necessary for your comfort and ease of both holding and aiming.

If the stock is made of wood, the best way of ensuring that it stays straight is to make it of two or three boards laminated from hardwood, and only well seasoned wood.

You also can use three, 3/8 boards that are glued together. If a band saw is not available, then you can easily shape the 3/8-inch boards with a coping or saber saw before being glued together.

By leaving the center board blank, you can form the opening for the trigger mechanism and the bolt groove, if you are using heavier bolts.

The shape of the butt also needs careful consideration. Using a crossbow, we need a much higher trajectory at 100 yards, so you can probably slide the butt much farther down the shoulder to achieve the required elevation when aiming at the longer distance. This means that the crossbow butt must have a long and shallow curve compared with the short, deep curve of the rifle butt.

How to prevent damaging your fingers when they get in the way of the string when shooting. To insure against such an accident, make the stock at least 3 15/16 inches deep at the point where the supporting hand will be grasping it. A long deep groove, in which the fingers can

THE CONSTRUCTION OF CROSS BOWS & OTHER WEAPONS

get a grip, will reduce the likelihood of any such accident.

The raw material for the stock is hard wood of some sort, cut from a plank that will be roughly 35 inch x 8 inch x 1 2 inch. Any good hard wood will do, but choose one in which the grain is not coarse.

Walnut makes an ideal stock, and so does maple, if you can find a well-seasoned piece.

From your pattern, trace the final patterns on the blank and then cut it out with a band or a saber saw. Be sure that the top of the barrel is absolutely straight and level. Rounds off the edges and corners with a wood rasp, and finish with sandpaper.

When your stock is finished, you will be ready to cut the trigger and latch position, which is done from the top of the barrel. Measure forward 14 inches from the butt of the stock and center down the barrel. This will be the after edge of the latch inlet. We cut down the inlet with chisels so it emerges in the center of the trigger guard. It should be exactly $9/16$ inch wide, $9/32$ inch on either side of the barrel centerline. From the 14-inch mark, the inlet extends forward for two inches. When you are finished, the trigger latch inlet will be two inches long by wide and the back edge will be located 14 inches forward of the butt. Take out the material with chisels and when done, smooth with sandpaper so no roughness will interfere with the smooth action of the trigger and the latch, once we have inserted them.

Your next step is to cut the bolt groove, which runs forward from the latch inlet to the end of the barrel. On either side of dead center, mark out a line $3/32$ -inch, so that your groove markings cover a spread of $3/16$ inch along the barrel. Take out the material between your two lines to a depth of 2 inch that can be done on a table saw. It is very important that this groove is dead straight, since it forms the track along which your bolt will pass as it leaves the string.

With the rough groove cut, sand the sides and bottom to a good finish. Now, take an arrow dowel and wrap it with fine sandpaper. Using this sanding dowel, work back and forth along the groove until you have a $1/16$ -inch chamfer made, along which the arrow will travel. Your bolt, if they have fletched it, will travel down this chamfered groove, with the cock feather riding in the bottom of the groove. Make sure that the finish of the wood is as smooth as possible. Friction, acting against the bolt, will not only act to impede its flight but may make for trifling inaccuracies that will multiply when it comes to actual shooting.

The cover plates are necessary to hold the trigger latch pins in place and later another pair to hold the prod in position in the stock, will be needed. They can be made of either plain wood to match or contrast with your stock or we can build them up from contrasting laminations for a dressy effect. The basic sizes will be apparent. Nevertheless, the actual sizes and shapes will be up to you so your finished crossbow will be as fancy or as practical and utilitarian as you want.

We can make the latch itself from brass, aluminum, or steel. You should cut the two pieces according to the drawings you choose and finished. (You can make the patterns from the

THE CONSTRUCTION OF CROSS BOWS & OTHER WEAPONS

drawings included and enlarged to size at a copy shop). The trigger requires a better finish than does the actual latch, since it will be in use against your finger. The two holes, which will hold the pivoting pins, are drilled into the fiber with care and the corresponding holes drilled into the stock with equal precision. The pins themselves should either be 1/8 inch or 3/16-inch diameter, cut from good hard steel and finished down so they move freely when the trigger latch assembly is in place within the stock. We can make the spring from piano wire or some type of small-coiled spring.

Bend or shorten the material to the shape you want, and then adjust the spring to keep your pull completely easy. Properly done, the trigger release should be as smooth as that of a good rifle. After finishing the trigger parts, assemble in the stock and check for smooth performance. If you find any roughness, polish the latch or trigger until their action is smooth and not sticky. Now the trigger parts can be set into the stock under the two cover plates discussed in the previous paragraph. Mounting the cover plates with fine brass wood screws that are countersunk into the cover plates is better. If at some future date, you have difficulty with the trigger assembly, we can remove the cover plates and correct the trouble.

Now, make a cover for your latch, keeping in mind that this must be high enough over your barrel to allow the bolt or quarrel to fit in underneath it. We can make it as a single piece or in two pieces, and then we glue the cover into position immediately behind the latch position.

You now slot the fore piece of the barrel to hold the prod. Now, you should cut the slot so when we lock the prod into position and its top is 3/8 inch below the barrel. The actual position of the slot and its angle in relation to the length of the barrel is governed by the draw length of the prod.

We must cut the slot at a slight angle, rather than on the square. If you made the cuts in the normal fashion, the bowstring, on release, would travel forward along the barrel, creating an incredible amount of friction and wear on the string. Therefore, with the slot cut off the perpendicular, we reduce the frictional wear.

The depth of your prod governs the actual width of the slot so do not make the actual cut until the prod is completed. The prod should fit snugly but without any binding.

The lock plate on some designs should be the width of the barrel and will be five inches long and 1/8 inch thick. It should be set into the wood by means of wood screws. Usually, nuts will give you sufficient pressure to hold the assembly firm. We should make cover plates to screw into the sides of the barrel, immediately above the prod lock cover. These cover plates serve to cover the wedge and add to the attractiveness of the finished crossbow, and their size and your design will determine the shape.

We must carefully make the trigger cover to exact dimensions to prevent the string from jumping over the catch before we have released it. Two diamond-shaped plates of Formica can be fixed to the sides of the stock with a single screw each, in such a position that they cover the two pins and keep them in place.

THE CONSTRUCTION OF CROSS BOWS & OTHER WEAPONS

You can make the bolt-holding spring from half a normal mortise-lock spring, which is usually shaped like a wide-open AV Cutting through the center circle, separates the two limbs and leaves a half circle on each limb. We can drill and fix the larger limb in the catch cover groove so a complete semicircle is in front of the cover. This will hold the bolt down in the breech.

A Prod up to 80 lb. or 90-lb. pull on the prod can be cocked by hand, but even then, it is a help to have a stirrup against which to pull the string when cocking. For a pull of more than 100 lb., and providing a lever of some sort for cocking the string is important.

Make sure that the stock is as finely finished as possible, using sandpaper. The finish of the stock itself should be a good varnish. When ready, apply the varnish and allow drying and then sand it down to a smooth finish. You then need to apply a second coat, allow drying and then rubbing briskly, continuing this process until you have the high gloss finish. When completely dry, rub on a good grade of silicone wax that will guard the stock against weathering.

THE CONSTRUCTION OF CROSS BOWS & OTHER WEAPONS

MAKING A HUNTING STOCK

You must make the stock for a steel bow from hardwood because of the heavier drawing weight. I have always used a laminated stock for prods of 100 pounds or more drawing weight. There is a distinctive jar when steel bows are fired, and on weaker stocks I have had trouble with them splitting.

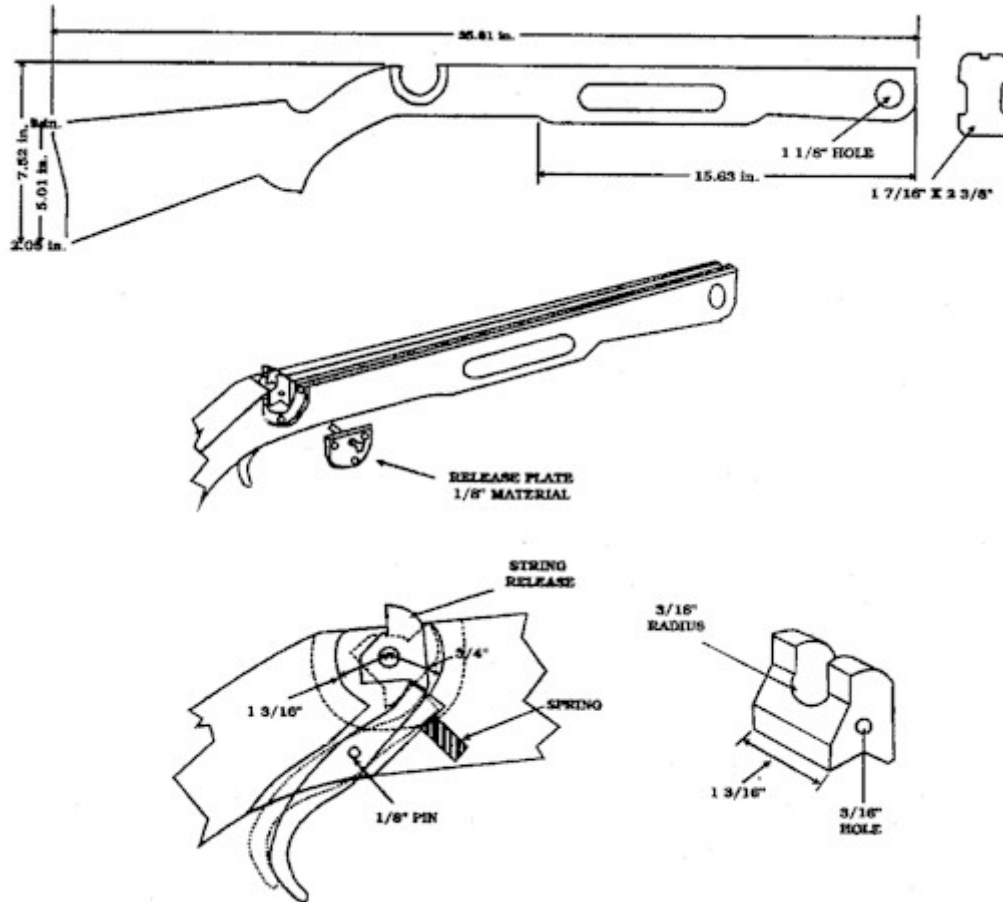

STOCK FOR WOOD PROD

Refer to the drawings for the dimensions of this stock. I would recommend making a laminated stock that we describe in the chapter on stocks. You should lay the stock out full size on a cardboard pattern and then transfer to the wood. Cut out the stock to the shape of the pattern.

After cutting out the stock, refer to the drawing and cut out the recess for the lock or release. I use a six by 1/8 inch thick steel or brass side plate on each side of the stock. You can either screw this plate to the stock, or mortise into the stock or a neater appearance. Using a side plate is very important, as wood is not strong enough for the heavier steel bows. After you make the cut for the release, turn the stock over and cut out a 3/16 slot into the underside of the stock for the trigger. If you are careful, you can probably drill out most of this area, and then clean it up with a wide chisel. A router would be useful also in cutting out the trigger

THE CONSTRUCTION OF CROSS BOWS & OTHER WEAPONS

groove, and the groove in the stock for the arrow or bolt.

If you are going to use heavy bows, you might consider using a metal string track to protect the wood. The string track is a piece of brass, aluminum, or steel, 1/8 Inch thick by 1/4 inch wide going the full length of the arrow groove. You mount this track on both sides of the arrow groove and fasten it to the stock by eight brass screws countersunk into the track on each side.

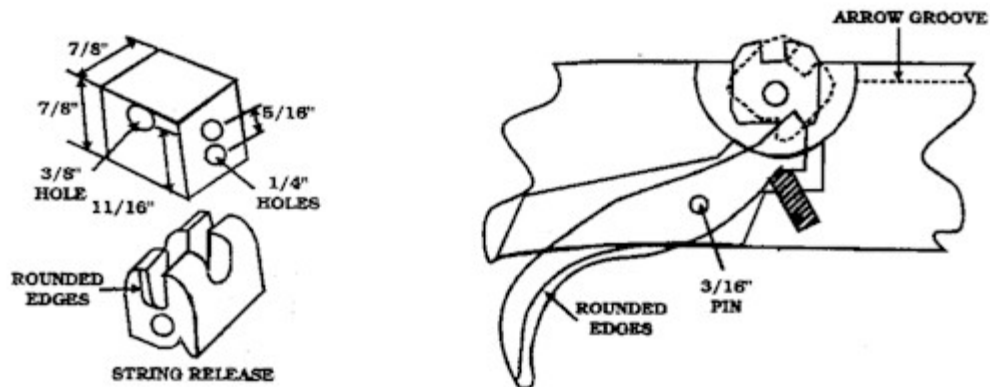
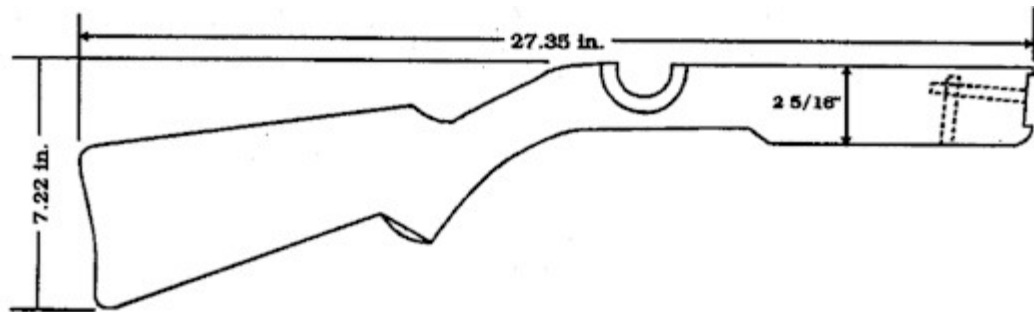

STOCK FOR METAL CROSSBOW

If you laminate your stock, and after all the glue has set up, all the edges except the bolt groove must be rounded with a rasp or coarse file. Leave the area on the stock where the trigger and release go, flat for now.

The top of this bolt groove must be absolutely flat and smooth. Then, you screw strips of Formica or thin brass on top to give a long straight gap of 3/16-inch width. This can be slightly wider if you are using heavier bolts, and you should position them down the dead center of the stock. The smoothness of Formica makes a good surface on which the bolt and string can ride, but brass will last longer.

THE CONSTRUCTION OF CROSS BOWS & OTHER WEAPONS

Any sharp edges should be rounded, and the entire surface of the stock should now be fine sanded and painted with a clear wood filler or sealer. When the filler is hard, sand it again and apply two or three coats of clear varnish or polyurethane applied. You can cut out the trigger and release, made of steel with a metal cutting band saw, or a hand saw, see the drawings for the dimension.

After you cut out the parts, finish with a rat-tail file and finish as smooth as possible. On the release, the outside corners should be hand sanded with fine grit emery cloth and then finish with crocus cloth.

On the forend of the stock, I use 3-1/8 steel pins for keeping the stock in alignment. A bolt and three-1/8 inch steel locating pins fasten the bow to the end of the stock. You drill the hole for the 5/16 by 3-1/2 inch bolt into the forend to a depth of four inches. You then turn the stock over and drill a hole deep enough to fit a 5/16 square nut inside it. The nut intercepts the hole for the bolt and will give support when the bolt is tightened.

Slip the square nut down into the hole on the underside of the stock, and then insert the 5/16-inch bolt into the hole. Start and screw the bolt into the nut and tighten the bolt up tight enough to seat it in the wood. Once you seat it, a little glue or silicon will hold it in place.

You can plug this hole with a dowel in of the correct size after you securely fasten the nut inside the hole.

Mount the bow into place on the front of the stock. Take the 5/16-inch bolt, and screw it into the stock to hold the bow securely. Now, mark the front of the bow for drilling the 1/8-inch hole for the steel pins. I used one pin at the top, and two on the bottom of the bow. Remove the bow from the stock, and then drill the 3-1/8 inch holes into the bow. Remount the bow and with a drill bit that is slightly smaller than the pins and drill the three holes into the stock 3/8 inch deep. Drive the pins into the stock through the hole in the bow. Get a 1-1/2 inch washer and place it on the 5/16-inch bolt, then screw it back into the stock.

All that you need now is to finish the stock. (See the chapter on finishing wood) You can rasp the stock to shape, and then finish with wood files and sandpaper. Refer to the chapter on finishing wood, to select the type of finish that you want to apply. For a hunting stock, I prefer a Tung oil or another type of oil finish. The oil finish is easier to maintain under hunting conditions.

THE CONSTRUCTION OF CROSS BOWS & OTHER WEAPONS

MAKING A TARGET CROSSBOW STOCK - TWO

The most important factor for accuracy in a crossbow is that of the stock, especially the bolt groove, it should be totally straight. This is very difficult to guarantee if you use a solid piece a wood because of the possibility of warping. In other chapters, I suggest that you use and least three, three 3/8-inch boards, better yet, get five, 1/8 to 1/4 inch boards. There are other advantages in laminated wood to form the stock. If a small band saw is not available, you can easily shape the boards with a coping saw before you glue them together. You can make the opening for the trigger mechanism and the bolt groove by leaving the centerboard blank where required. (See the chapter on laminating stocks)

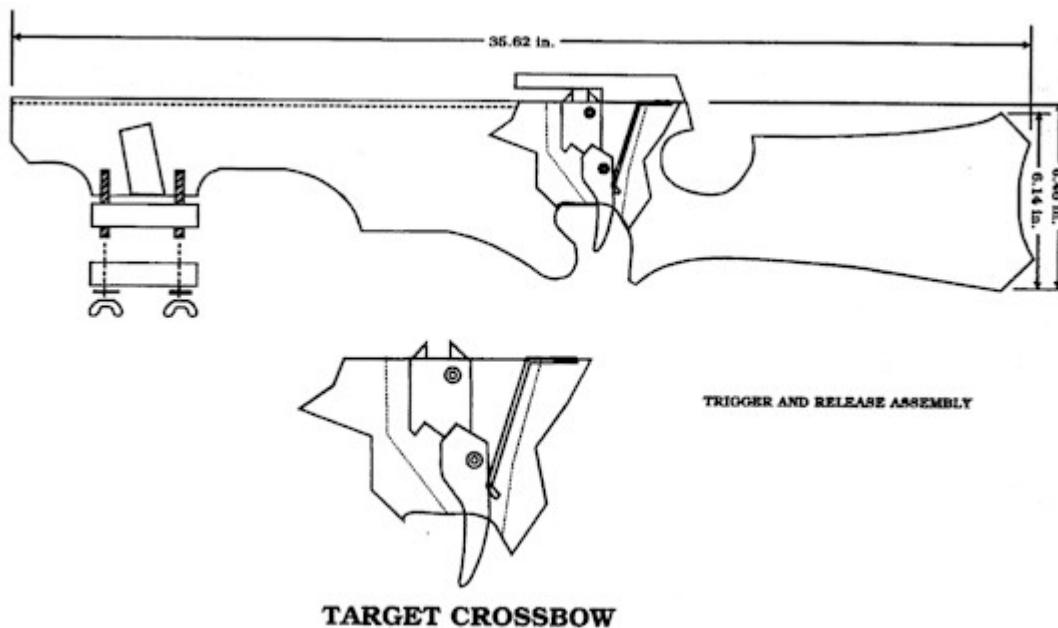

For appearance a good choice would be walnut, mahogany, and maple, all three are easy to work and take a good finish. Using a combination of maple and walnut or mahogany laminated together will make a very attractive stock.

You need three or five-boards, 3 feet by 8 inches depending on their thickness to get the needed for the stock. You should mark the shape of the stock paper or cardboard, you then transfer the pattern to the boards and cut out with a small band saw, coping, or jig saw. The centerboards should then be cut into the required lengths to avoid the spaces taken by the trigger mortise and the upper groove. (See the chapter on laminating stocks for instructions)

After all the glue has set up, all the edges except the bolt groove must be rounded with a rasp or coarse file. Leave the area on the stock where the trigger and release will mount, flat for now as you will need the flat surface to drill the pin holes for the trigger and release. The top of this bolt groove must be absolutely flat and smooth, and then you glue or screw strips of Formica or thin brass on top to give a long straight gap of 3/16-inch width down the dead center. The smoothness of Formica makes a good surface on which the bolt and string can

THE CONSTRUCTION OF CROSS BOWS & OTHER WEAPONS

ride.

Any sharp edges should be rounded, and the entire surface of the stock should now be fine sanded and painted all over with a clear wood filler. When the filler is hard, thoroughly sand it again and apply another two or three coats. (See the chapter on finishing)

The middle of the stock must be deep enough to protect the fingers and thumb of the left hand from being caught by the string. A 1/4-inch wide you could cut groove parallel with the bottom edge, its center about 1/4 inch from the bottom, but this is optional. This groove can start on both sides about 2 inches from the trigger guard and run forward for about five to six-inches. A router could be used to cut this groove, or if a router is not available a round chisel can be used.

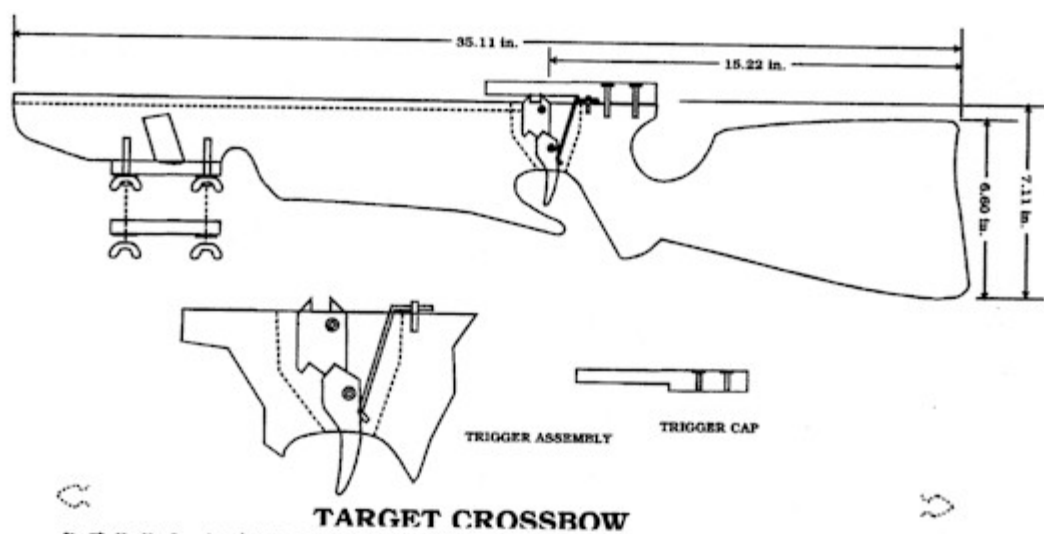

The trigger and catch, made of 5/16 inch or 3/8 inch aluminum or brass plate, but tool steel that is case hardened, at least on the parts that have mutual contact would give longer service. Cut the shape of the trigger and release as shown in the drawing. You must take care to round the upper left-hand surface of the trigger slightly to a radius. If you use tool steel, you must polish this surface before it is case hardened. There should be no roughness felt when you pull the trigger under the pressure of the bow. The pins holding the trigger and catch should be made of 1/4 inch steel rod and carefully positioned. Otherwise, the mechanism will not function properly and may become dangerous.

To get the release and trigger positioned right, cut the pattern for the trigger and release from cardboard. When you mark out this pattern, mark all the pinholes and make the pattern as accurate as possible. Where you marked the two hinge pins on the pattern, use two large pins and press them through the pattern in the exact center of the hinge pinhole. Next, position the release and trigger pattern on the side of the stock. This is right over where the stock has been opened up to except these parts.

When you feel you have them placed right, take the heavy pins and press them into the wood, this is where the hinge pins will be. Once you have the pins in place, you can check the

THE CONSTRUCTION OF CROSS BOWS & OTHER WEAPONS

alignment of the trigger and release. If one or the other is not set right, move it slightly and then reset the pin.

When you have the release and trigger right, you can then drill the holes for the pins, but be very careful that you get the drill started in the right place. I would suggest that you start the holes with a very small drill, which will help the larger drill keep in line when you start it.

TRIGGER COVER

You must also make the trigger cover carefully to prevent the string from jumping over the catch before they have released it. You make the clearance just high enough to clear the string. You now cut a groove into the underside of this cover deep enough so that it will allow the arrow or bolt to slip between the groove and the cover. You can make this cover from any type of hardwood, and should be approximately 3/4 inch thick by about five inches long. It should be the same width as the stock, however the length and thickness may vary slightly according to changes that you have made to the stock. On top of the trigger cover, you will fasten the bolt holding spring. This spring is nothing more than a thin flat spring, made from half a normal mortise-lock spring, which they usually shape like a wide-open V.

PROD SLOT

You cut the slot for the prod on the angle. This is done to relieve spring pressure during firing. If you mounted the prod exactly square to the stock, there would be a tremendous amount of wear on the string and the top of the stock. Do not cut out the opening for the prod until you have a prod made or bought. The actual dimensions that you cut the stock for, should be a very close fit on the prod. You should cut the slot where the top is about 1/2 inch of the top of the stock as shown in the drawings. When the prod is in place, it should be just sticking out from the slot, but if it is not, you can use a thin spacer so the prod cover will hold it securely.

PROD COVER

You make the prod cover from 3/8-inch thick wood, the same as stock. There two 1/4 inch wing nuts and bolts that you screw into the stock so that you can easily dismantle the prod when required. If you do not want to use wing nuts, you should screw it to the stock.

FRONT SIGHT

The front sight can be a blade made of a small wire bent to an L shape and is mounted to the side of the stock an inch or two from the forward end. You should mount it high enough to give plenty of room for the bolt and its feathers to pass under. (See the chapter on bow sights)

The rear sight must have some means of considerable adjustment vertically and a slight adjustment laterally, for windage. There are some good rifle sights available that works well with crossbows. I have used rear sights from military rifles that would give me enough

THE CONSTRUCTION OF CROSS BOWS & OTHER WEAPONS

elevation for the different ranges that I shot. Most all these sights have enough windage adjustment to sight in the crossbow, but if it does not, you can adjust the front sight. When you finish the sights, you spray a flat black paint on the front and back sights to avoid any glare when aiming.

THE CONSTRUCTION OF CROSS BOWS & OTHER WEAPONS

MAKING A REPEATING CROSSBOW

The Chinese used a repeating crossbow in battle, and it was very effective. It was not accurate, as the lever used to fire it could not be used steady. The design of this repeater was thus; below the pile of bolts, the magazine had a narrow channel in which the string traveled. As the lever brought the magazine forward, the string was cocked by dropping into a groove at the back end of this channel, just below the rear of the next bolt to be shot.

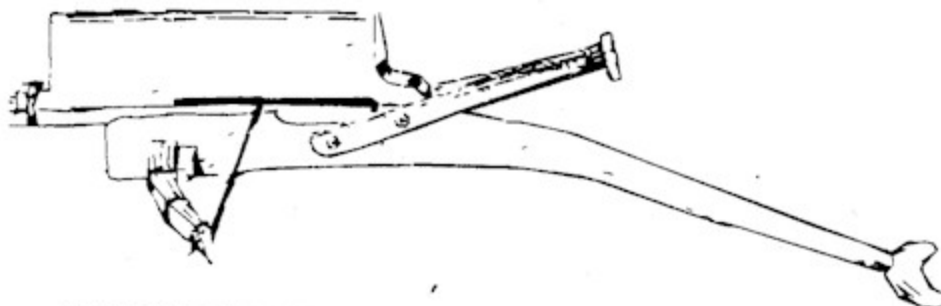

THE REPEATING CHINESE CROSSBOW

When the lever pulled the magazine back again, it also drew the string with it until the bow was fully drawn. At this point, a piece of rod in a hole immediately beneath the string registered with the string in the groove. As they brought the lever down the piece of rod went through the hole, pushed the string out of the groove and released it behind the bolt (see Item 8).

By this method, the bolts could be shot one after the other as fast as the lever could be worked back and forth. However, because the bolts were not fletched, they were suitable only for short-range shooting. Accurate aiming was not possible because of the movement of the lever on releasing.

The first repeating crossbow that I know of in this country was first made by George Stevens of Marcella, Ark., as a toy for a young boy. The weapons power and accuracy surprised Stevens, and he continued to build it.

Throughout history the crossbow has always been more powerful than the long bow, but as a military weapon it fell into disuse during the thirteenth century because the longbow permitted faster nocking and shooting.

However, George Stevens's rapid-fire crossbow shoots (or bolts) in five seconds, making it as fast-shooting a weapon as the longbow.

I had read about his repeating crossbow in 1958, and decided to try my luck at making it, but not having the article anymore I had to build one on my own design. It took quite a bit of scaling, building, and trying to come up with a good workable repeating crossbow.

THE CONSTRUCTION OF CROSS BOWS & OTHER WEAPONS

I found that with simple wood working tools, the repeating crossbow was simple and easy to make. The bow was more of a problem, but the first bow was a solid glass bow that I made for children. After shorting it down, I could increase the strength of the bow to about 45 pounds.

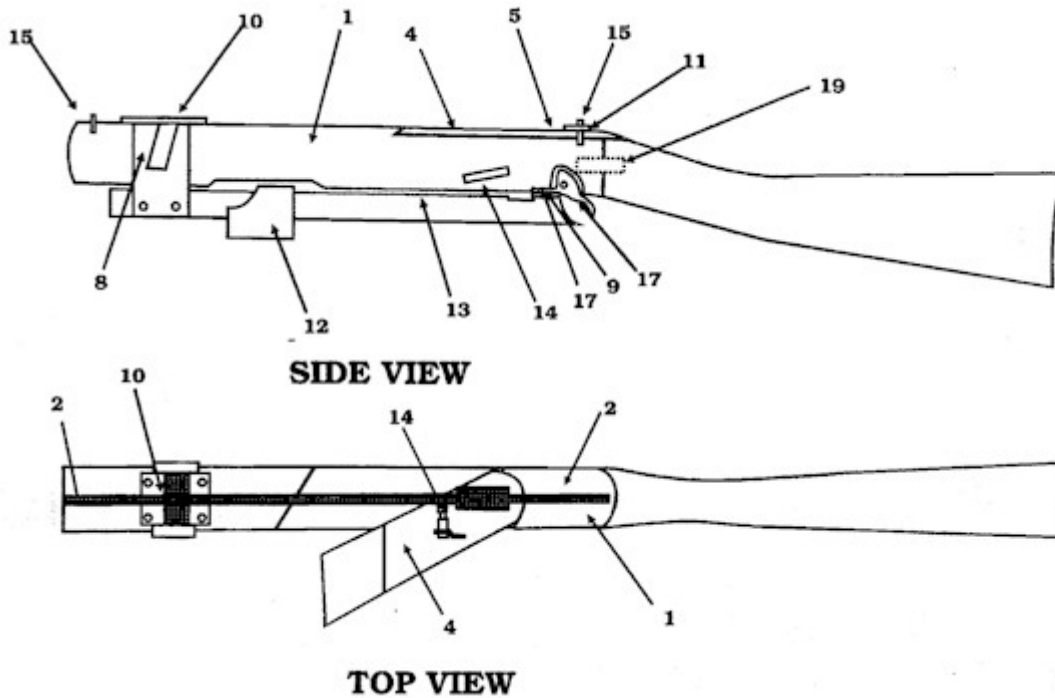

For target shooting, this was about right, but for small game, I found this a little on the light side. I then shortened down a 40-pound glass bow, and came up with a pull of 65 pounds. This weight worked out just about right for small and medium game but it still did not have much accuracy at a distance.

The 65-lbs. weight is too much for using the slide, but with the repeating feature of this crossbow made it very handy for hunting.

THE CONSTRUCTION OF CROSS BOWS & OTHER WEAPONS

MAKING THE REPEATING CROSSBOW

Wood: The wood used for the repeating crossbow should be a hardwood: Oak, walnut, maple, birch, can be used. The raw material for the stock is hard wood of some sort, cut from a plank that will be roughly 35 inch long by 8 inches deep and 1-1/2 inches thick.

Any good hard wood will do, but choose one in which the grain is not soft. Walnut makes an ideal stock, if you can find a well-seasoned piece.

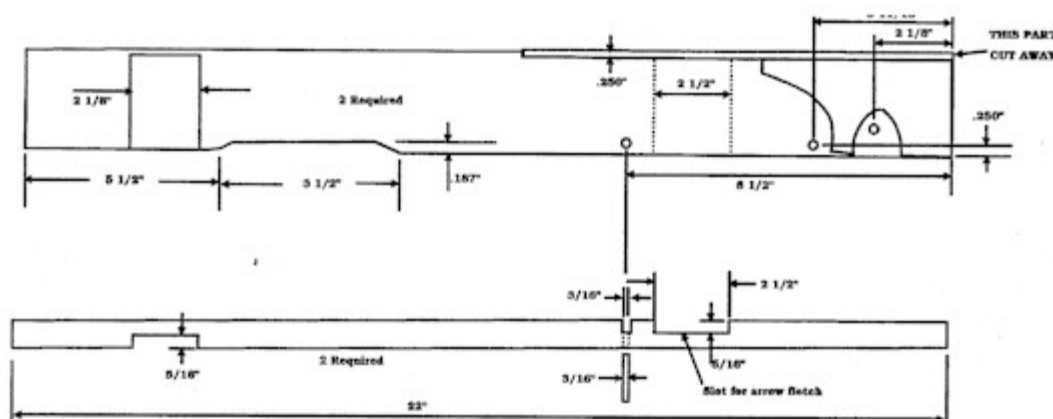

ITEM #1 FOREND MAGAZINE ASSEMBLY

Next is the butt stock. We did not give a detailed drawing of this as we have found that there is too much difference in the size of people. The best is to cut a stock made from a pattern of a rifle or shotgun of the desired length.

You can cut the complete stock from the lumber and cut it to shape. This will make a strong stock that you can shape to fit you. What we have given here, is tile drawing for a stock for average size. This can be changed to fit any person, use the dimensions on tile drawing only as a reference.

We can make the stock from an old gunstock, or glue two pieces of hardwood together and cut it out to the desired shape. We can then drill and join the forend and butt stock with a one-inch dowel. The two should be fitted close and then glued with a good epoxy such as twin weld, or similar. You can see this in Item 19.

The shape of the stock should be first drawn on cardboard, you then transfer the pattern to the two outer boards and cut out with a small band saw, coping, or jig saw.

The center board, which will have the grain placed vertically, should then be cut into the required lengths to avoid the spaces taken by the trigger mortise and the upper groove.

From your revised outline, trace the final pattern on the blank and then rough out with a band saw, jig, or coping saw if it is available. Be sure that the top of the barrel is absolutely

THE CONSTRUCTION OF CROSS BOWS & OTHER WEAPONS

straight and level. Round off your edges, corners with wood rasps and finish with sandpaper.

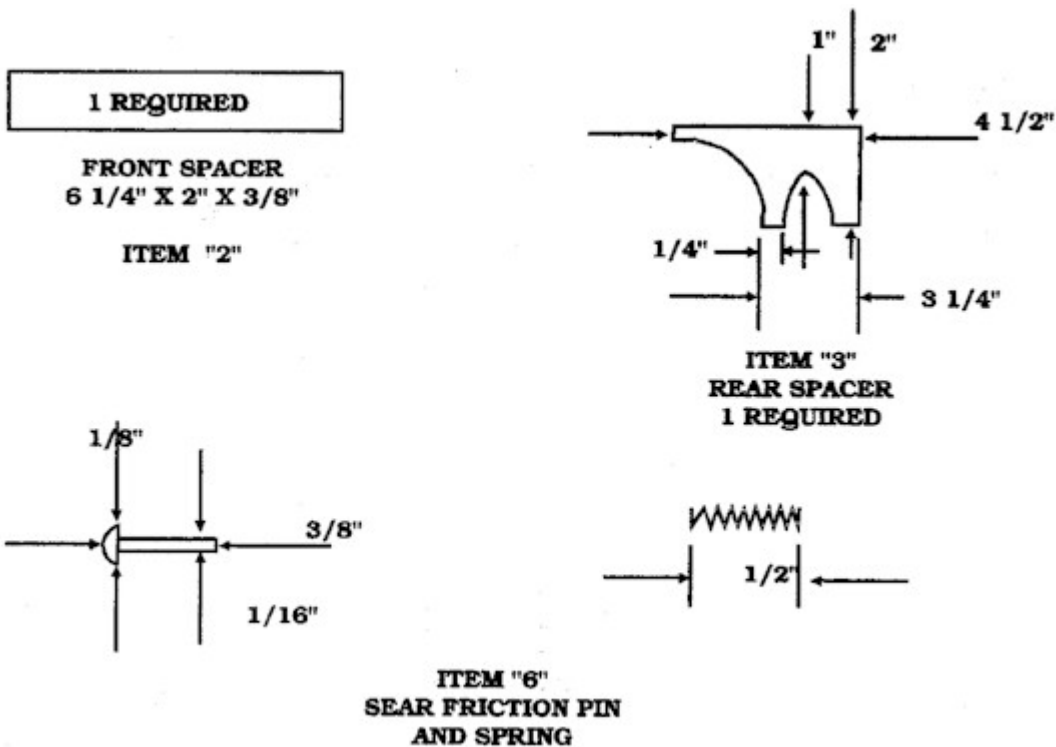

For the heavier bows, the harder woods should be used, and we glue together a one by six-inch hardwood lumber for most of the construction. The lumber should be flat, and not twisted. You will adapt the design here then to your own length of arm and face contours. To check the way, in which the design will fit your face and arms, lay out the pattern on a cardboard blank and after cutting it out check for fit. You can make whatever adjustments are necessary for your own comfort and ease of both holding and aiming.

After selecting the wood, cut off one end of the board 23 inches long, as Item No. 1. You will need two for gluing together; these are your top barrel or magazine.

Do not cut the forward slots for the bow plate yet, just the groove for the fletching of the arrows. Your next step is to cut the bolt groove, which runs forward from the latch inlet to the end of the barrel. On either side of dead center, mark out a line 3/32-inch, so that your groove markings cover a spread of 3/16 inch along the barrel.

Take out the material between your two lines and to a depth of 1/2-inch. It is vitally important that this groove is dead straight, since it forms the track along which your bolt will pass as it leaves the string.

With the rough groove cut, sand the sides and bottom to a good finish. Now, take an arrow dowel and wrap it with fine sandpaper. Using this sanding dowel, work back and forth along the groove until you have a 1/16-inch chamfer made, along which the arrow will travel. Your bolt, if you have fletched it, will travel down this chamfered groove, with the cock feather riding

THE CONSTRUCTION OF CROSS BOWS & OTHER WEAPONS

in the bottom of the groove. Make sure that the finish of the wood is as smooth as possible. Friction, acting against the bolt, will not only act to impede its flight but may make for trifling inaccuracies that will multiply themselves when it comes to actual shooting.

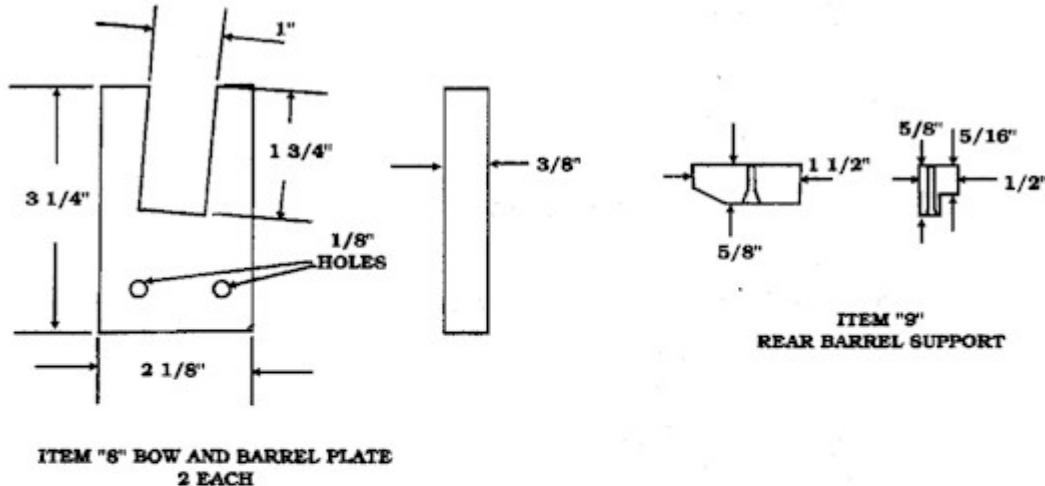

The reason for not cutting the bow plate slot yet is that it also holds the lower barrel, and the depth has to be exact.

Cut the two spacers, the diameter of the arrows that you are going to shoot determines the thickness of the spacers. The thickness shown is for 11/32-inch size. We will glue these between the two pieces that you made in No. 2. Use good waterproof glue for this that we can purchase from any lumber yard.

After gluing the two together, you are ready to cut the magazine cover. Cut 1/4 inch off the top of the magazine as shown in the drawing, for the plate and cover. We glue it to the back part of the magazine, and we later taper the back part to the contour of the butt stock. The top of the magazine has to be hand fitted to fit Item 4.

Now, make the lower barrel assembly, Item 13, and the rear barrel support Item 9. These have to be made first, then we can cut out the bow plate Item 8. After getting we cut out the barrel, cut the slot in the magazine for the bow plate as in Item 1.

The depth should be just deep enough so that the bow plate will just hold the barrel slightly, Item 20. After getting all of the above made, cut now the relief slot for the as in Item 1. This is

THE CONSTRUCTION OF CROSS BOWS & OTHER WEAPONS

the slight taper next to the bow plate, and gives the necessary clearance for the pump slide to clear the string.

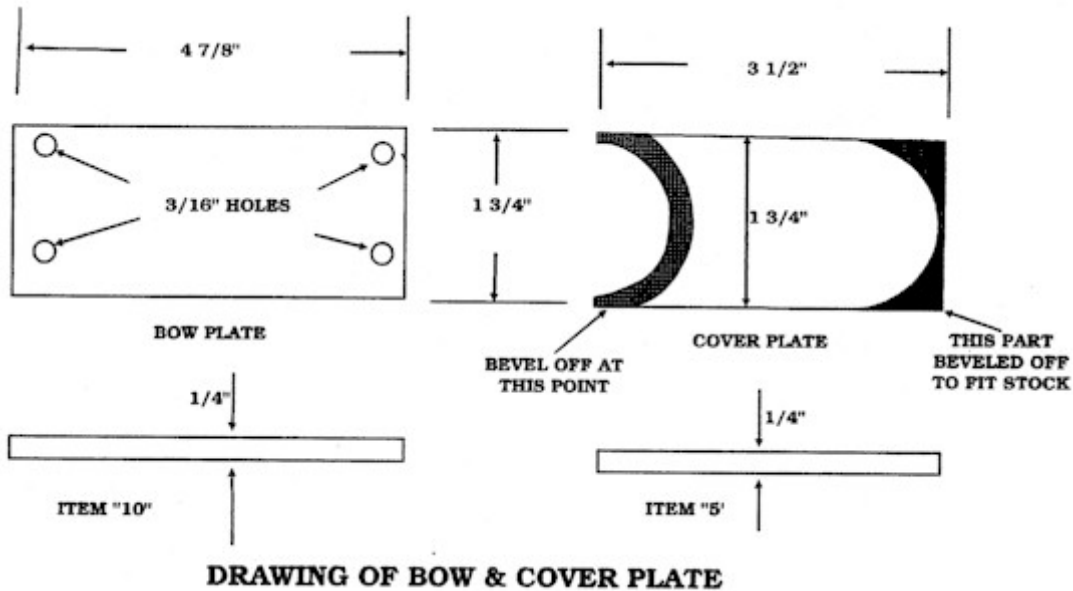

Next make the cocking slides as in Item 12; we now glue the two pieces together. You can make the slide to fit your hand.

For bows up to 50#, you can use this as the cocking piece. On heavier bows, you should lock it back in the slot on the barrel with two screws, as the heavier bows cannot be cocked with this slide.

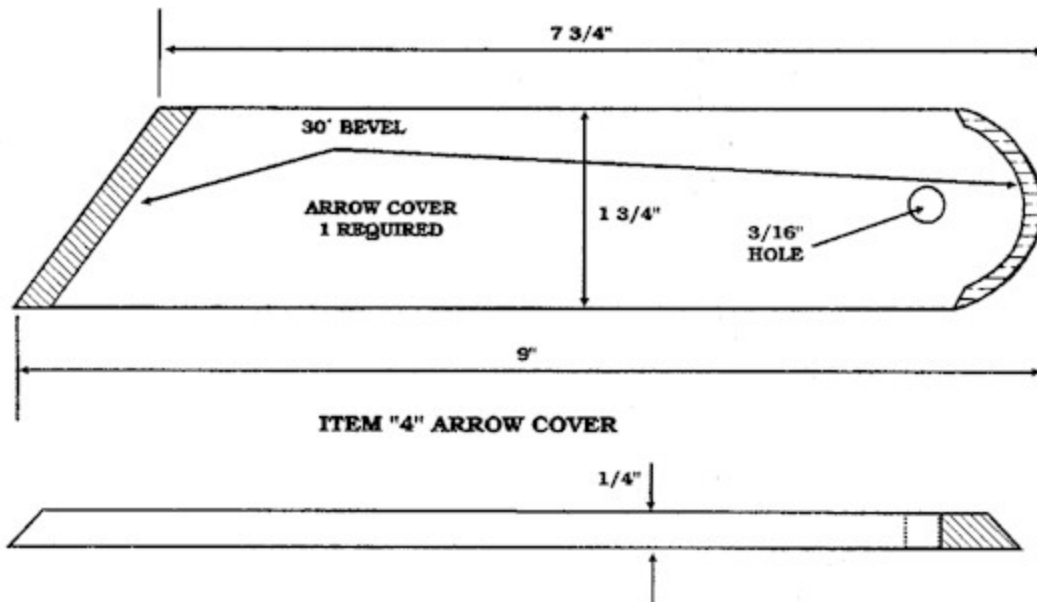

All that has to be done with this method of cocking is just pull back the string until it latches,

THE CONSTRUCTION OF CROSS BOWS & OTHER WEAPONS

press the arrow release lever and it is ready to fire.

With all of this completed, cut out the triggers, you make it from 5/16-inch aluminum plate. Drill the hole in the stock for the trigger, stick the pin in the hole, lay the trigger in place on the outside of stock, hold the sear in place, and mark the hole for it.

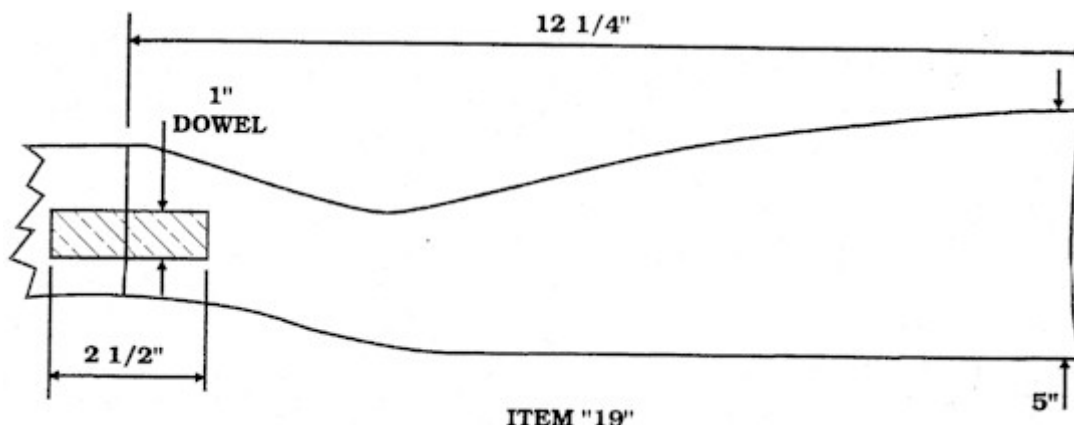

We can make the latch, either from metal or sheet fiber. Metal is more lasting but is more difficult to work. Fiber cuts and works easily and for ordinary uses it is more than adequate. We should cut the two pieces according to the drawings and finished. The trigger requires a better finish than does the actual latch, since it will be in use against your finger.

Drill the two holes, which will hold the pivoting pins, into the fiber with care and the corresponding holes drilled into the stock with equal precision. The pins themselves should be either 1/8 inch or 3/16 inch and cut from a hard round steel rod. They are finished down so that they move freely when the trigger latch assembly is in place within the stock.

The actual spring, which we show in the drawings, is made from any small coil spring, or from wire. Properly done, the trigger release should be as smooth as that of a good rifle.

Once we have made all the components, assemble in the stock and check for smooth performance. If there is any roughness, smooth the latch or trigger until their action is completely free of trouble.

You should make the friction pin as In Item 6, and Item 7. This keeps the sear in the fired position for easy cocking. The bow is next. You can use a solid glass bow or one made to fit that is in the various catalogs. Whatever the case, it should be fitted, and should not be shorter than 36 inches.

Bow blanks can be purchased ready for use from various crossbow manufactures, or blanks already glued for tillering, shaping, and completed bows. You can cut down and make solid fiberglass bows to fit, are they are very tough but are not too satisfactory for target use. (See the chapter on Fiberglass bows)

THE CONSTRUCTION OF CROSS BOWS & OTHER WEAPONS

All that is left to do is to shape and contour, mount sights, and finish.

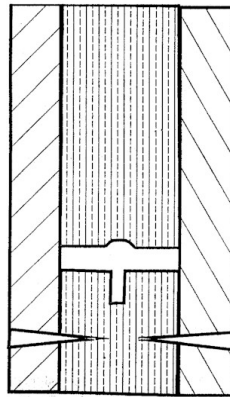

ITEM "20"
FRONT VIEW OF
MAGAZINE & BARREL

In Item 14 is an arrow release. This is not necessary but I have found that it is well worth the time to install it in the magazine. The purpose of this is to hold the arrows in the magazine until you are ready to drop them in place, just by pressing the lever.

With this, you can also unload the crossbow without dropping the rest of the arrows from the magazine.

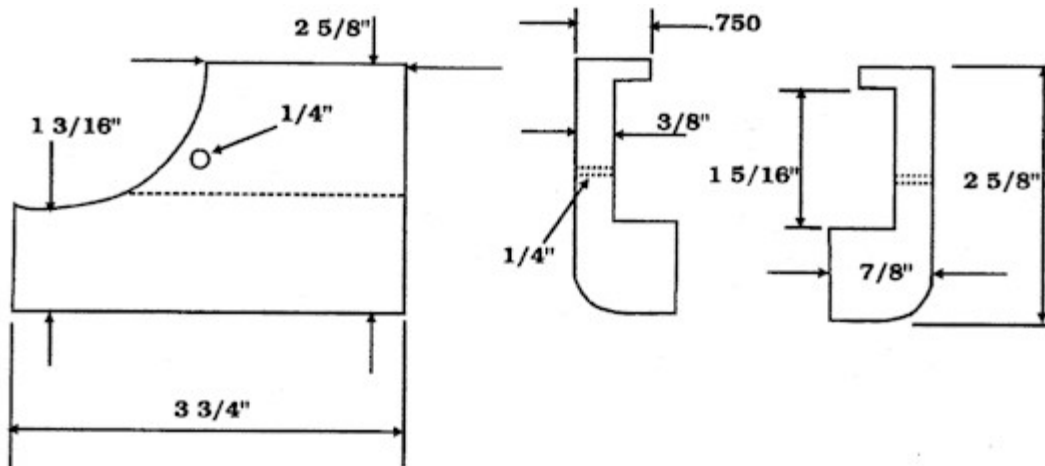

ITEM "12"
COCKING SLIDE OR PUMP

The arrow length should be about ten to eighteen inches and is two fletch, but under some uses you will want to use three fletch. The accuracy of the repeating crossbow is extra good, as it is essentially shooting from a barrel.

THE CONSTRUCTION OF CROSS BOWS & OTHER WEAPONS

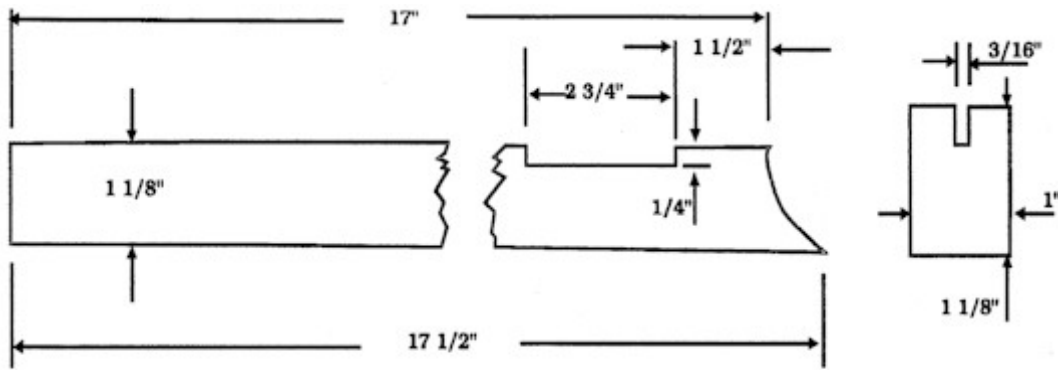

ITEM "13"
BARREL OR ARROW TRACK

Aluminum arrows work great, but we should change the dimensions for the smaller sizes.

The more powerful bows give more accuracy, distance, and with the lighter aluminum arrows will shoot much better.

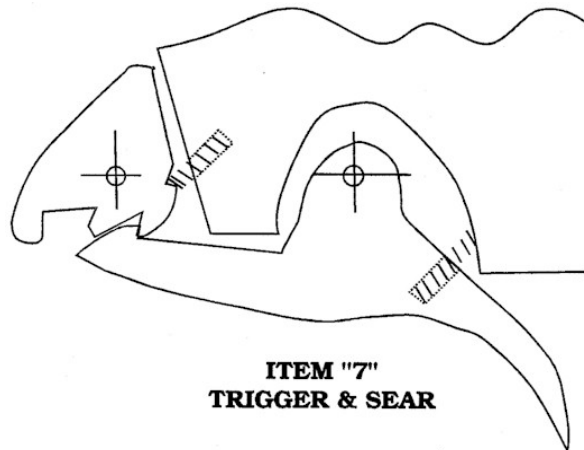

ITEM "7"
TRIGGER & SEAR

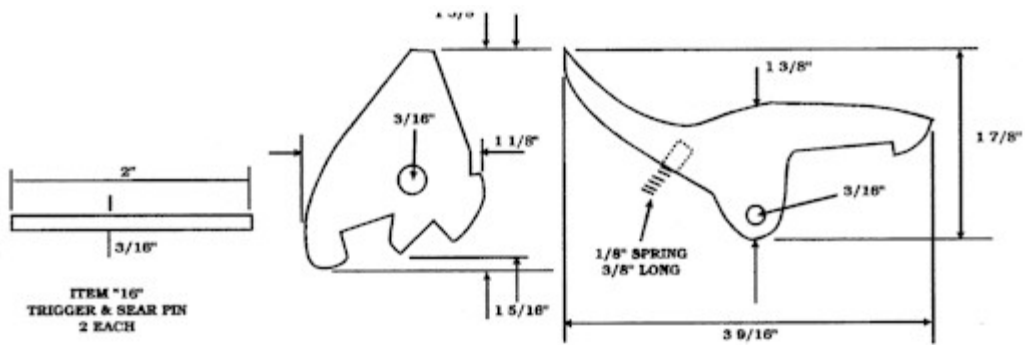

ITEM "16"
TRIGGER & SEAR PIN
2 EACH

ITEM "17"
SEAR & TRIGGER

THE CONSTRUCTION OF CROSS BOWS & OTHER WEAPONS

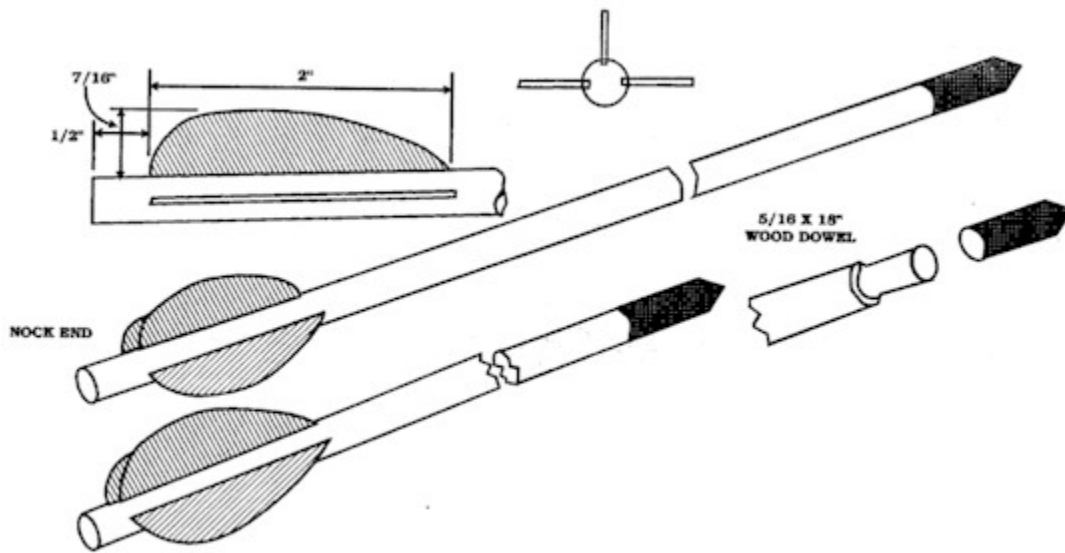
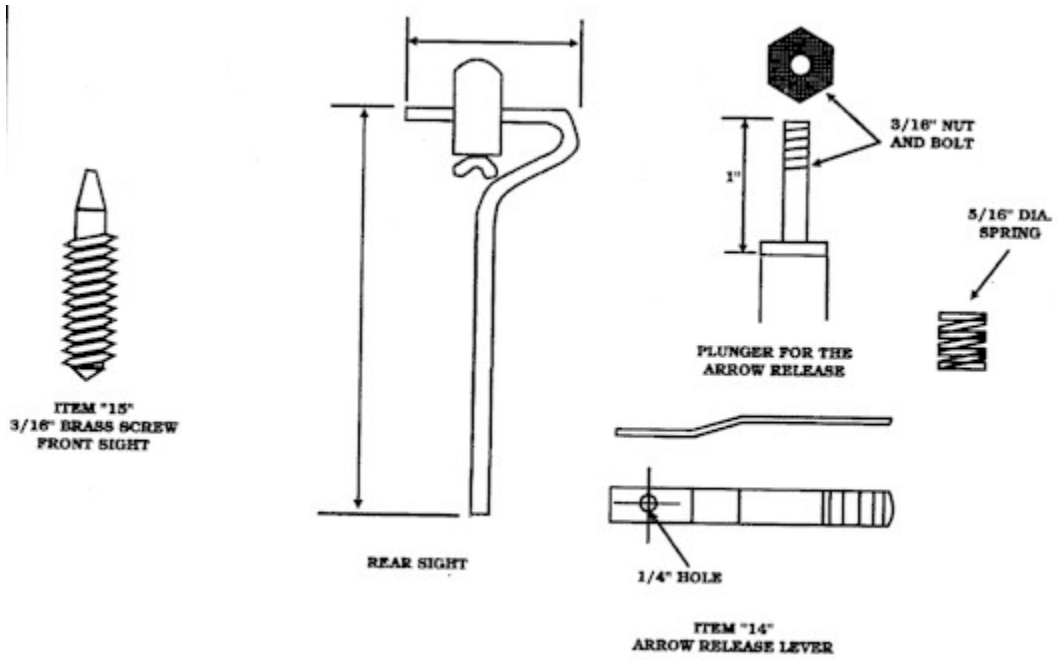

CROSS BOW BOLTS

THE CONSTRUCTION OF CROSS BOWS & OTHER WEAPONS

MAKING A BALL REPEATING CROSSBOW

The repeating ball crossbow is very similar to the arrow-repeating crossbow, and it will shoot balls or marbles from 1/2 inch up to 1 inch plus wood bolts. Be forewarned, this type of crossbow is no toy, with a ball of 5/8 inch to 3/4-inch diameters, there is plenty of power to kill most small game.

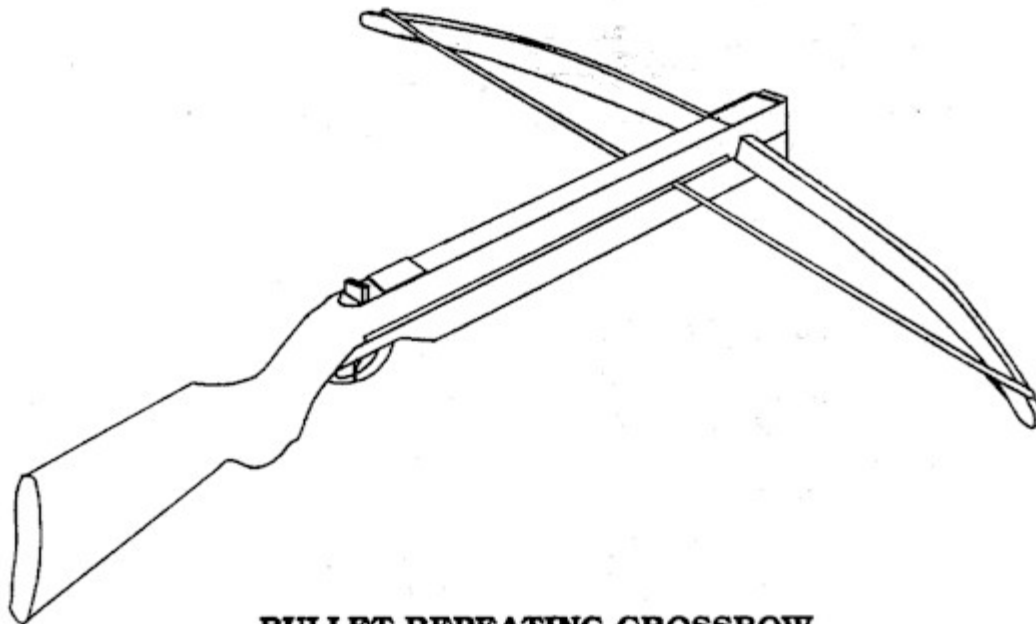

BULLET REPEATING CROSSBOW

If good hardwood is available, you can make the stock in one piece, but I prefer to laminate the stock material. If the wood should warp, you will not have much accuracy. A reliable crossbow requires a solid, knotless and first-grade piece of lumber that is big enough to make the stock.

The completed stock that is 36 inches long makes up the overall length of the finished weapon. Usually the longer the barrel, the better the aim, but the crossbow must not become so long that it is unmanageable. We start with a piece of lumber 38 inch long and 8 inches wide, or if you are going to laminate the stock you will need two boards the above size. This size is necessary owing to the angle formed between the stock and the butt. This angle is about 10 degrees.

I have made several types of bullet crossbows, and I will show you how to make both types. The first type is a repeating bullet type, and the second one is a single shot made for balls or short bolts.

THE CONSTRUCTION OF CROSS BOWS & OTHER WEAPONS

LAMINATING THE STOCK

If you are going to laminate the stock, choose the hardwood boards that are flat and smooth so you can get good glue joint. Maple, Walnut, Birch, or other hardwood is suitable for making these stocks. You will need to find a one by eight hardwood board eight feet long for making the bullet crossbow stock. You can get good wood glue from your local Lumber Yard for gluing these boards together. Several "C" clamps are needed to clamp and hold the two boards together while drying.

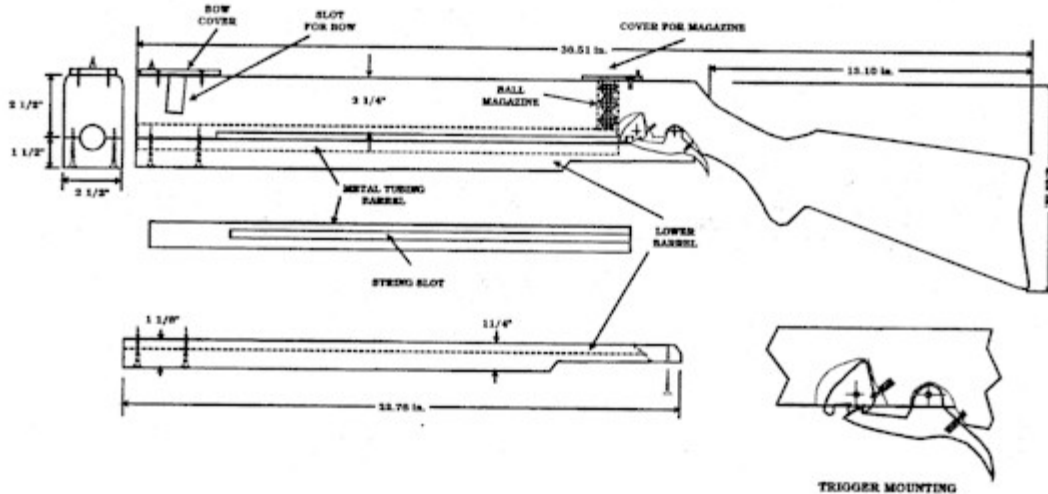

REPEATING BULLET CROSSBOW

After buying the hardwood board, cut two boards to an overall length of 38 inches. Lay these two boards together and see how flat they lie. If they fit closely together, you can then glue them together. Read the instructions on using the glue, and then mix up the required amount that you think you will need, you can mix the glue in a plastic bowl.

Have your "C" clamps (probably about eight will be sufficient) handy, and a paintbrush for applying the glue. Lay the two boards side by side and apply a thin coat of glue to the surfaces of both boards. Next, place both boards together and starting at one end clamp the boards together. Apply the clamps equally on both sides and all the way around the boards. Two or you may need three large clamps to clamp the center of the two boards. Otherwise, there may be a thick glue joint in the center.

Do not over tighten the clamps or you will have a starved glue joint, just tighten the clamps enough that you squeeze the glue out as you clamp the boards together. Let the glued boards set over night, and then the next day you can cut out the stock.

The thickness of the material depends on the caliber of the crossbow that is on the internal diameter of the barrel. We will assume that this diameter is 5/8 inch. For a wall thickness of 7/16 inch, this requires a total thickness of 1-1/2.

THE CONSTRUCTION OF CROSS BOWS & OTHER WEAPONS

Even if you choose a smaller caliber, say 3/8-inch, do not use thin material, since the buff must be thick enough to fit your shoulder snugly.

BUILDING THE CROSSBOW

The construction of the crossbow begins with a drawing that is then used to transfer the profile of the stock and butt onto the wood. After cutting out the rough shape with a band saw, start work on the two slots for the bow and the trigger mechanism. The farther the bow is set forward, the greater its drawing weight will be. A good place for the bow is 2-1/2 inches behind the muzzle and is the foreword edge of the bow slot. The width and height depend on the construction of the bow, varying between 3/4-inch, and 1-1/2-inch. The bottom of the slot must lie at least 3-inches above the bottom of the stock. We should cut out the sidewalls very carefully, and they should be exactly at right angles to the axis of the stock.

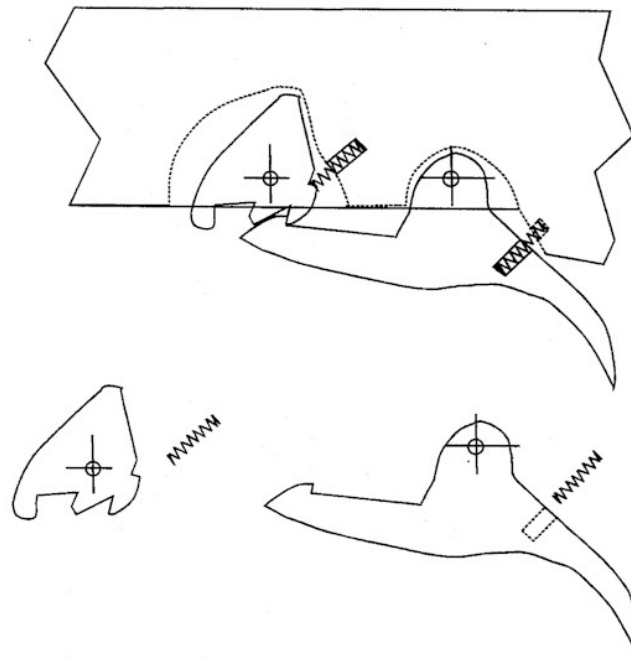

**TRIGGER AND RELEASE
FOR REPEATING BULLET CROSSBOW**

TRIGGER

The slot for the trigger mechanism is 3-inches wide and, as distinct from the bow slot, runs parallel to the axis of the stock (Refer to the drawing). Make a full size copy of the crossbow pattern at a copy shop for accuracy in making the pattern. The rear wall of the narrow chamber lies flush with the rear end of the bowstring slot. A chamber length of about 1-1/2-inch is enough, since the trigger does not have to travel very far, and they only slightly weaken the lower barrel.

STOCK

THE CONSTRUCTION OF CROSS BOWS & OTHER WEAPONS

After cutting out these two slots, take plenty of sandpaper and a rasp and carefully shape the butt and stock, including the thickening at the bow slot and the hand guard. All sharp edges and corners should be gently rounded since the crossbow should be handsome and comfortable to handle. Consider carefully where to form the hand guard.

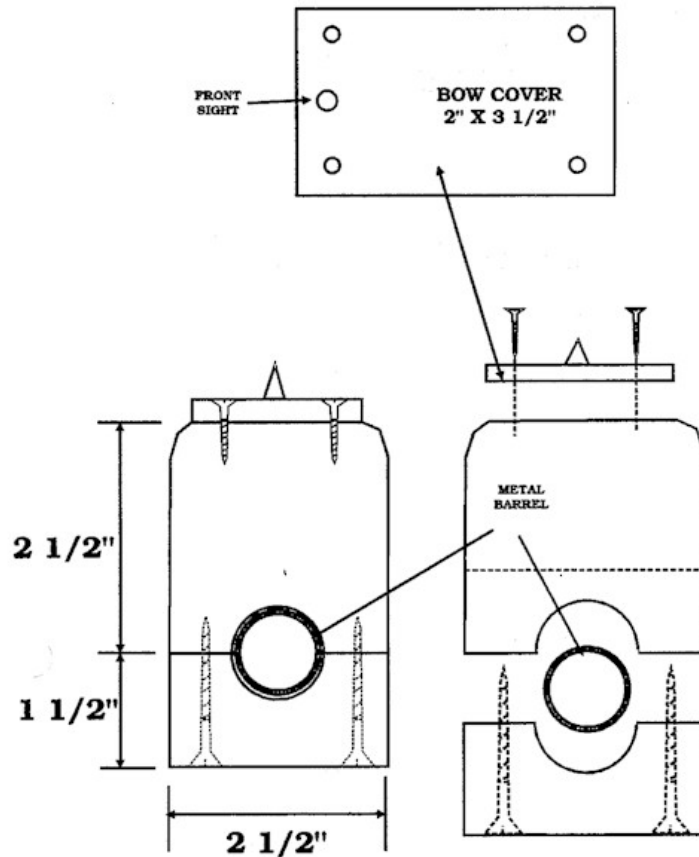

BULLET REPEATING CROSSBOW FRONT VIEW

Crossbow men with a long reach may wish to move the hand guard an inch or so forward. In any case, it must lie beyond the center of gravity of the weapon. An unbalanced crossbow will tire the arm and cause eyestrain because of the wavering of the sights. They will adapt the crossbow to the needs of the individual Bowman.

BARREL

The next step is to true up the two halves of the barrel, for the independent upper half, use a piece of wood 23 inch long and 3/4-inches thick, of the same sort as used for the stock.

THE CONSTRUCTION OF CROSS BOWS & OTHER WEAPONS

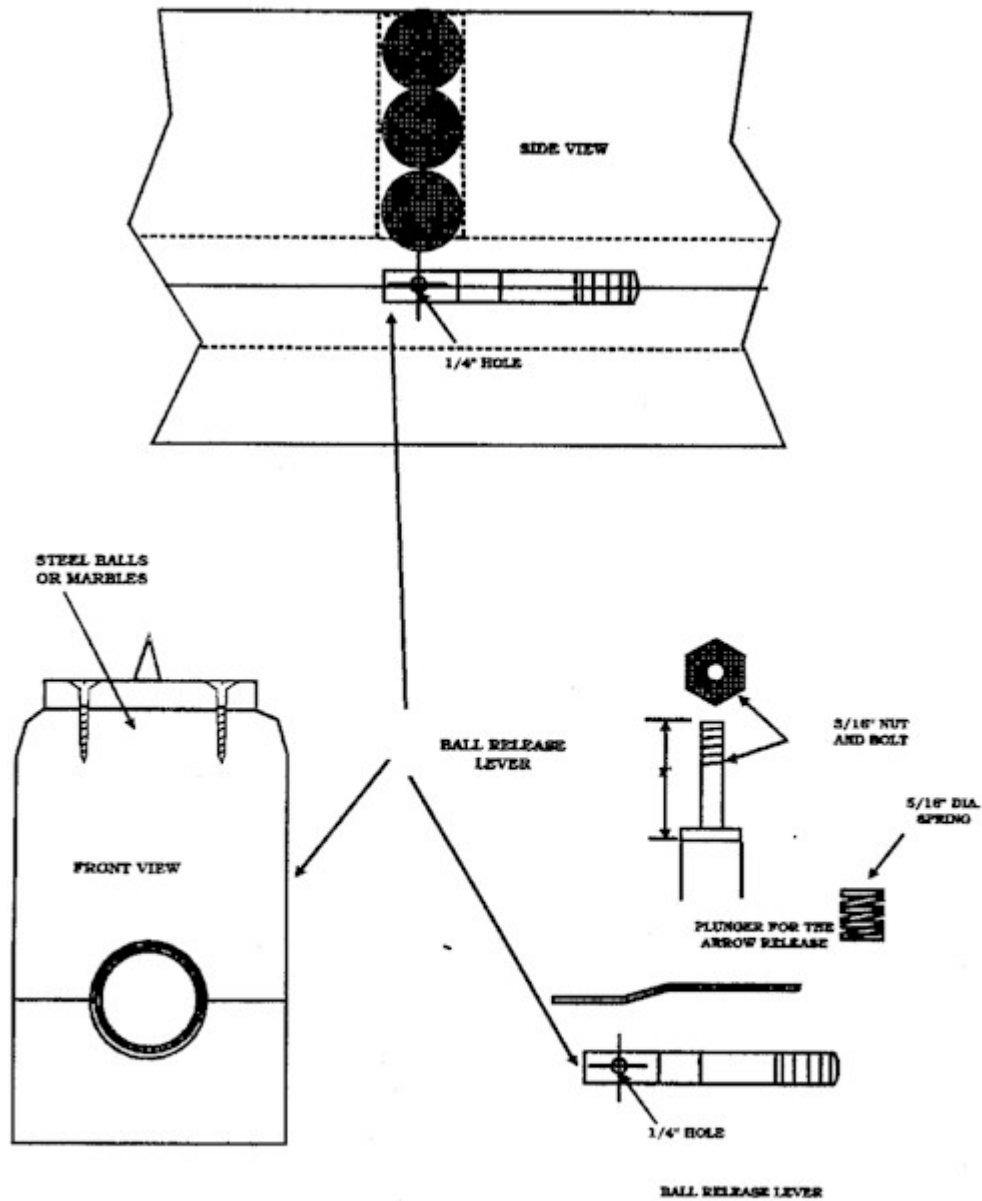

BALL RELEASE ARRANGEMENT FOR BALL CROSSBOW

The inside faces of both halves of the barrel flat. Then, with a marking gage mark the diameter of the barrel, which lies in the middle of the two surfaces, cut out the corresponding channels with a gouge or router. Rub them down to the exact semicircular form, starting with the stock. You can make the entire barrel this way, and if it is routed true and will even make an accurate bore.

The best way of ensuring an ideally straight barrel is to get a sufficiently long (about 12 inches) round iron bar with a diameter slightly less than the final caliber or ball size of the barrel. Wrap it in emery paper, and sand down the entire length of the barrel to the required

THE CONSTRUCTION OF CROSS BOWS & OTHER WEAPONS

depth and the correct profile. The barrel ends at the front wall of the trigger chamber. If you are going to use a metal barrel, all that we will need is to route the hole large enough to fit the metal in place.

We treat the upper half of the barrel in the same way. You should not cut away the last 2-1/2 inches at the end of the stock; the last 2-1/2 inches must be kept their full thickness.

Then you remove 1/8 inch from the underside of the upper half of the barrel to form the bowstring slot. This slot starts 3-1/4 inches behind the muzzle and extends to a point 4 inch from the end of the stock. We reinforce the joints at the butt end and the bow end with flat-head brass wood screws driven vertically into the stock. We strengthen the joint at the other end by a strip of brass d-inch wide wrapped tightly around the muzzle and fixed to the stock with three small brass screws.

METAL BARREL

The entire fitting should be done, and everything completed before fitting the metal barrel. When fitting, set the barrel in place and screw the upper and lower half of the barrels together. With a sharp pointed scribe, mark the outside the barrel where the string will travel. You can then cut this out with a hacksaw or band saw. Be sure to cut the slot larger than the string and then sand smooth so the string will not rub on it, as this would surely cut the string. Then you drill a round hole through the top of the rear part of the metal tube so they can drop the balls into the barrel.

When all is fitted, we can permanently install the metal barrel into the stock with epoxy glue. Be sure there is no binding of the metal tube.

BALL RELEASE

Refer to the drawings for the details of installing it. Once the bow is cocked, by pressing the release lever, a ball will drop into the barrel. The ball magazine can have a swivel cover on it, or it can be left open.

BOW

Refer to the chapters on making a bow. A solid fiberglass bow that we have shortened will make a good bow. The width of the bow slot in the stock depends, as already mentioned, on the nature of the bow. It should be less for a simple bow, since we can then manage very well with a thickness of 1/2 inch in the middle. Avoid excessively long bows, as a span of 32 inches will be enough. Moreover, the shorter the distance between the bow and the trigger arm, the shorter the bow needs to be in length. Shortening the length increases the drawing weight, but also the risk of breakage of the bow.

You make the stock the same as above from either a one-piece hardwood or are laminated together using two boards. After the glue has set up, you will need to make a scaled drawing

THE CONSTRUCTION OF CROSS BOWS & OTHER WEAPONS

of the bullet crossbow shown in the drawing. Used a piece of cardboard from a large box and scale the drawing on it, then cut out the pattern and lay it on the board and trace out the pattern on it. The top cover for this crossbow is 23 inches long and $\frac{3}{4}$ inch thick and is cut from the material that you used for the stock.

THE CONSTRUCTION OF CROSS BOWS & OTHER WEAPONS

MAKING THE SINGLE SHOT BULLET CROSSBOW

Next, cut out the crossbow that you have traced on the laminated board. After you cut out the stock, you can cut out the slot for the prod year you should be careful so that the top of the slot must be at least 1/4 inch below the top of the stock. You will need a finished prod to get the dimensions that you will cut the slot in the stock. This slot is first drilled out and then chisel out very carefully to fit the handle on the prod. (Drawings can be used on the above.)

A 1/4-inch screw that you tap into the stock from the front to fastens the prod in the slot. There is an additional slot cut right in front of where the bow will set. A piece of 1/8 by 1/2 steel will fit into this slot, and you drill and tapped a hole for the 1/4 inch screw that mounts into the front of the crossbow stock. This slot should be about 2-1/2 inches behind the muzzle and is behind where we will place the front sight.

Now, you need to cut a slot into the stock or the trigger mechanism. Refer to the drawing for the location of the trigger box. The slot for the trigger will be cut 1/4 inch wide by 1-1/2 inch long, and the rear wall of this narrow chamber will lie flushed with the end of the bowstring slot. Refer to the drawing for the trigger and the safety that you will include with it.

Again, you can drill this slot out first with a slightly smaller drill bit, then finish by chiseling the two slots to the correct size and then file them smooth.

You now cut the barrel into the top upper half of the crossbow. This is the piece that you cut after cutting out the stock, and is 23 inches long and 3/4 inch thick. There is two ways to cut this barrel groove. (1) Carefully chisel out this groove for half the diameter of the ball or bolt that you intend to use. (2) Use a router to cut this groove into the upper barrel and lower barrel that is in the crossbow stock.

If you plan to chisel it out, you will need to mark a line on either side of the glue joint. Chiseling out the barrel is a slow and tedious job. After you chisel both barrels out, wrap some sandpaper around a straight one-rod that has a diameter slightly smaller than the finish bore of the barrel. Work the rod back and forth with the sandpaper on it to finish out the bore.

I would strongly suggest that you use a router to cut the barrel on both the top and the bottom. The barrel would be much smoother and more accurate, and you could do it in less than half the time. Remember, when you cut the slot in the upper half of the barrel, you should stop at 2-1/2 inches from the end of the stock and must retain their full thickness.

You remove the string groove on the underside of the upper half of the barrel next. The 1/2-inch slot starts 3-1/4 inches behind the muzzle of the crossbow and extends to a point 2-1/2 inch from the end of the stock.

THE CONSTRUCTION OF CROSS BOWS & OTHER WEAPONS

The easiest way to cut the string slot is to mark a line c inch from the bottom of the upper barrel, and cut it out with a band or coping saw. Keep to the lower side of the line when you saw it, so when completed you can file it flat and even.

THE CONSTRUCTION OF CROSS BOWS & OTHER WEAPONS

MAKING THE TRIGGER AND LOCK

There are many different types of crossbow locks and triggers. There are plain ones and there are highly complicated triggers and releases. When I speak of releases or locks, they are the same. My choice of triggers and releases is the one that I show for the steel bow, but the target trigger and release is also an excellent choice for most type of target shooting. A very simple and easy one to make is the aluminum trigger and latch drawing.

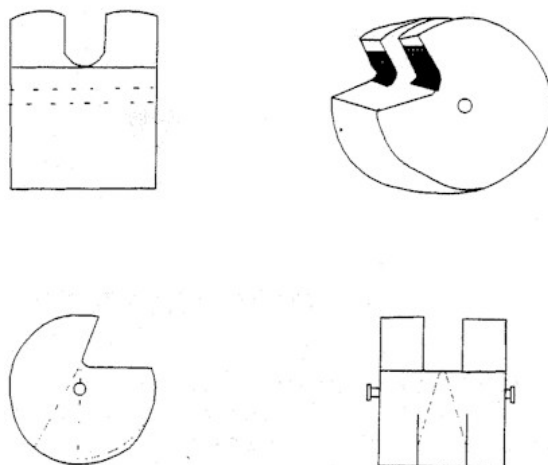

Revolving Nut On The Older Crossbows

There are several types of materials used for locks that can be used in making crossbows. You can make them from brass or aluminum, but making the locks out of steel is the best way to make them. For most shooters, triggers and releases made from brass or aluminum will be sufficient.

However, of these two materials, I would prefer brass, as it is more wear resistant. If you want the best, get some tool steel (O1 tool steel) to make the trigger and lock from. After you made and fitted them, you should finish the metal to a high polish. This is done with emery cloth, and then finished with crocus cloth to a polish finish. If you have a buffing wheel, it and the polish on it.

When you have the trigger and release completed, they will need to heat-treat. You can use a propane torch to heat-treat them, but a gas-welding torch would be better. You heat the parts to a bright red, and then quench them in five weight motor oil. After you quench the parts, they will be hard and brittle, so you will need to draw the hardness back. Heat your kitchen oven up to 450 degrees and place the trigger and release in the oven for thirty minutes. After removing the parts from the oven, they will need to be polish again.

THE CONSTRUCTION OF CROSS BOWS & OTHER WEAPONS

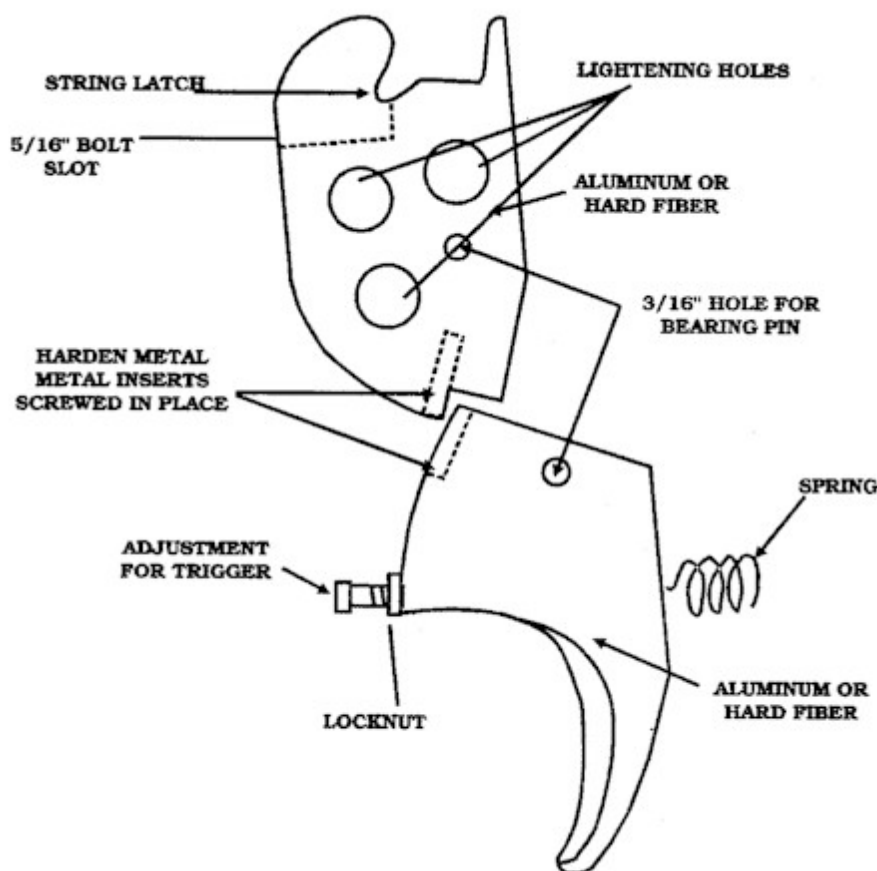

ALLOY TRIGGER FOR TARGET CROSSBOW

Though the different types of locks and triggers use different shapes, the process is the same for making them. The pins used for the trigger and release is made of steel that will vary in size from 1/8 to 1/4 inch depending on the type of crossbow and the pull of the prod. The heavier the prod, the larger the pin that you will use in the release. Normally, a 1/8-inch pin will be sufficient for the trigger.

You can copy the patterns shown in this book on a copy machine, but usually they will not be the correct size for your stock that you are making. Therefore, you can scale these drawings larger or smaller to fit your needs. I would recommend that you draw the trigger and release patterns on cardboard first. By doing this, you can cut the trigger and release out, and with a pin stuck through the pattern where the pin goes, you will have a working pattern. What I mean by a working pattern, you can place the release and trigger pattern on the side of the stock over the opening where you have cut where the trigger and release will go. Once you have these in the approximate location, press the pins firmly into the wood. Now by working the trigger you can judge if you have them in the right location. Normally, I set the release in the proper location, and then move and adjust the trigger until everything works right.

THE CONSTRUCTION OF CROSS BOWS & OTHER WEAPONS

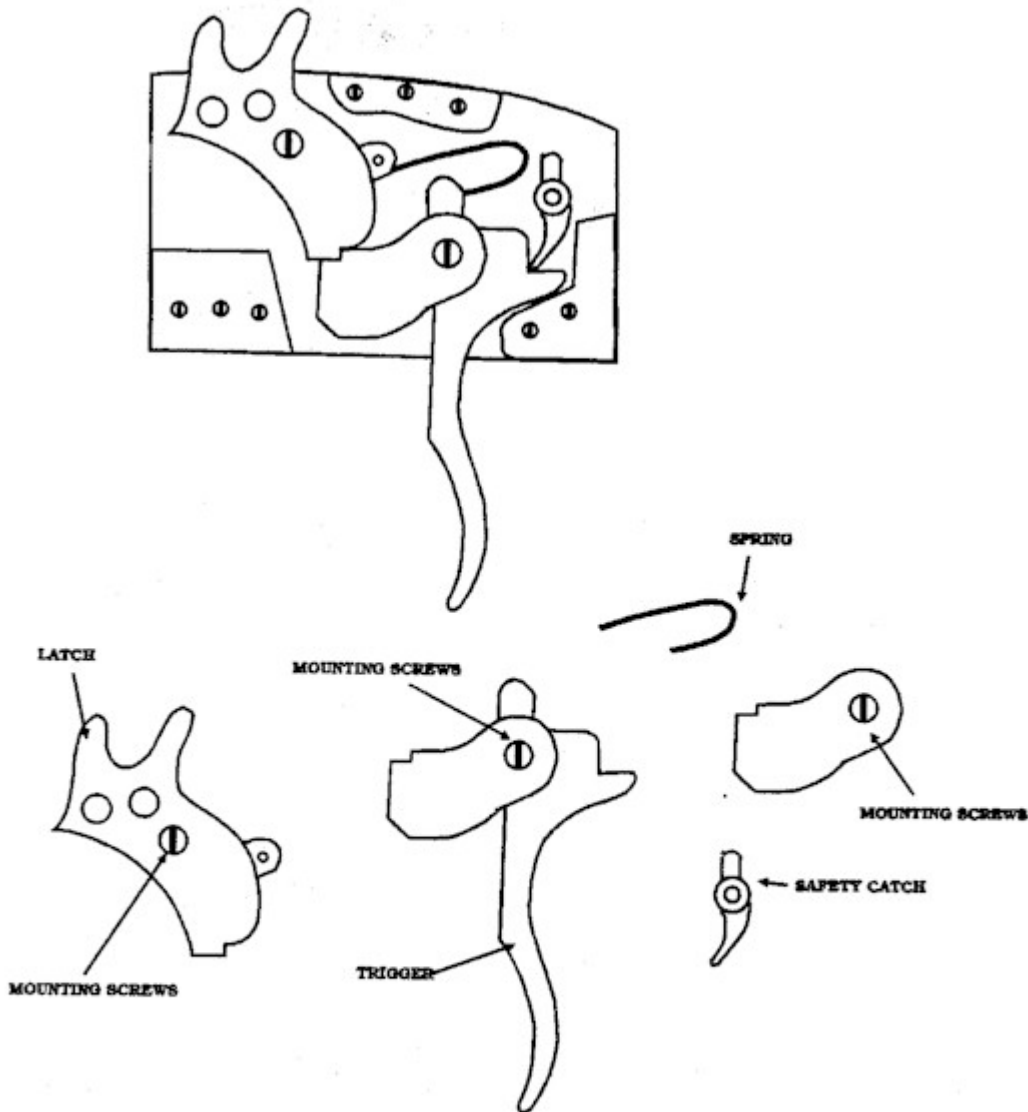

MODERN STEEL TRIGGER

When you have everything located right, tap the pins and make the holes deeper and then remove the trigger, release, and pins. The location where you had the pins pressed into the wood, is where you will drill the holes. I strongly recommend that you use a small drill to drill the first holes, and then enlarge them with the correct size drill.

After you cut out the trigger and release, drill the pinholes in them. Assemble the lock mechanism again on the outside of the stock to be sure everything works fine. If you are using a wire spring, you can shape it while the trigger and release are on the outside of the stock.

THE CONSTRUCTION OF CROSS BOWS & OTHER WEAPONS

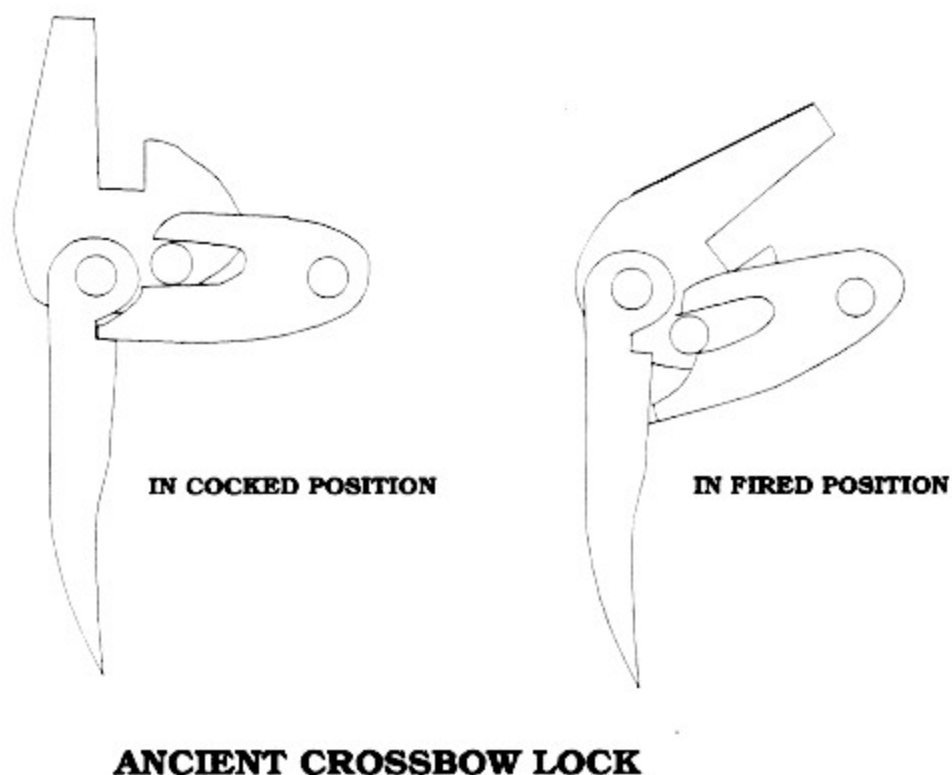

When you assemble the parts in the stock, lubricate the holes and pins with heavy grease and test the trigger pull. You can have someone pull on a 1/4-inch rope placed on the release to simulate the string. The trigger should pull easily, with about 1/4 inch of travel at the finger.

OUTLINING THE PARTS

You can also outline the crossbows= parts and drilling point with a grid, and this will allow you to make up scaled templates for the metal pieces. You must match the templates perfectly before tapping them to the metal and scribing their outline.

Then glue it to a piece of cardboard and use the finished drawings as explained in the above chapter.

Be extra careful when cutting out the stock, as the pieces must fit closely or you will be spending quite a bit of time with the file. The best way to cut the parts accurately is to use a band saw equipped with a metal-cutting blade. The smooth operation of the trigger and string release depends on the perfect alignment. Mark and drill the holes in the proper location, and you can use a flat board or the stock as described above to test the parts on to be sure that everything is right. If you want to check the fitting of the trigger and release on a board, align and clamp the trigger and latch in place on this board. Use the predrilled holes in the parts as a guide, and then drill through the board. If you feel certain that you can get a perfect alignment, you can use the stock instead of the board as is done in the above chapter.

THE CONSTRUCTION OF CROSS BOWS & OTHER WEAPONS

CLEARANCE

The trigger and release need to have clearance to allow them freedom of movement within the stock.

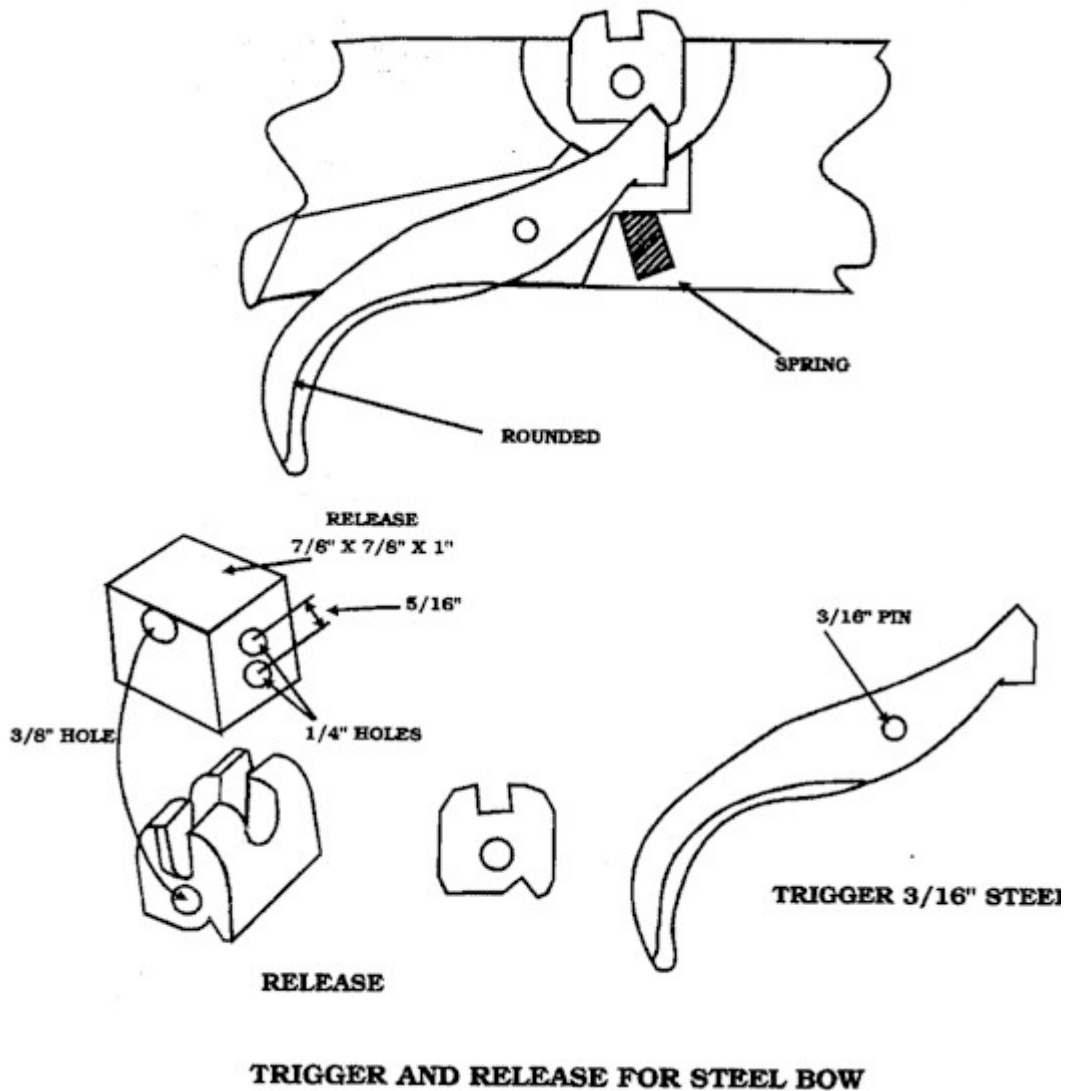

The trigger is returned by small compression springs set in slots cut through the central spine, or set in the opening of the stock.

If you make the shape of the trigger and release from steel, you must take care to round the upper left-hand surface of the trigger slightly to a radius. You must polish this surface before it is case hardened so that no roughness is felt when you pull the trigger under pressure.

The pins holding the release should be made of 1/4-inch steel, while the trigger and can be

THE CONSTRUCTION OF CROSS BOWS & OTHER WEAPONS

made of 1/8-inch steel.

They trigger and you must carefully position release, otherwise, they will not function properly and may go off by itself.

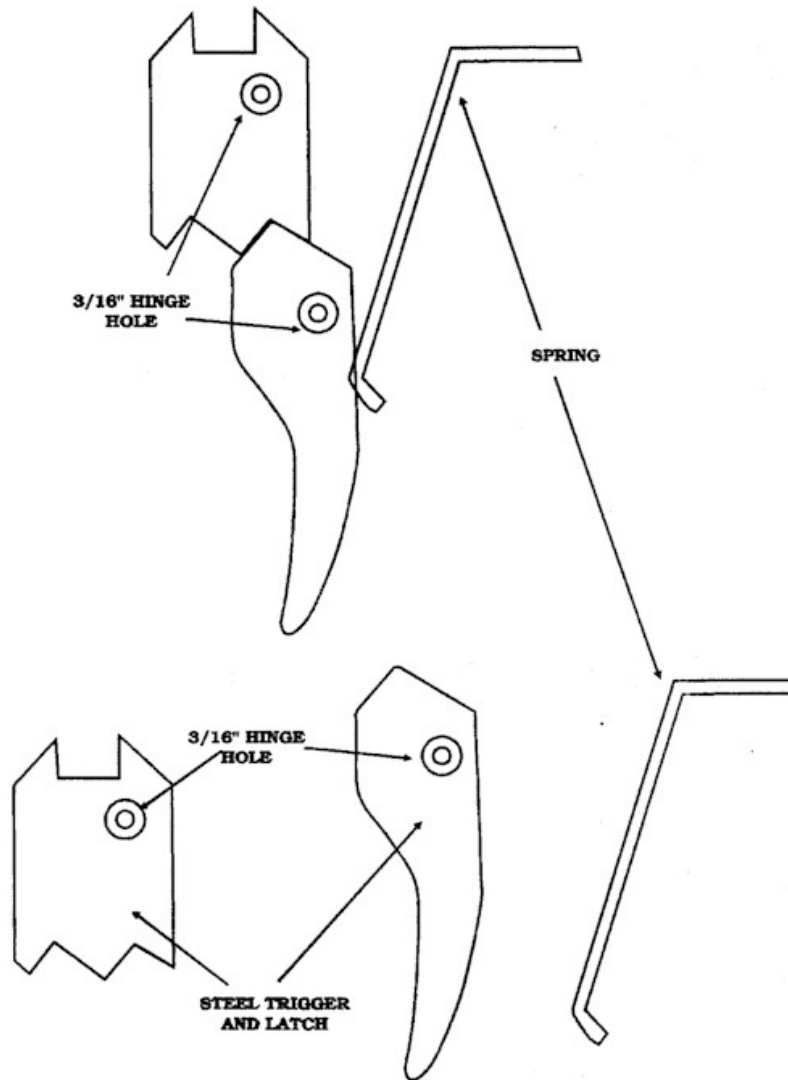

TARGET TRIGGER

Next, you cut out the trigger assembly of aluminum or brass plate that is 1/4 inch thick. If you can find it, use brass, as it is tougher than aluminum. When you make up the trigger and locked, draw it out on thin cardboard and mark the pinhole location.

THE CONSTRUCTION OF CROSS BOWS & OTHER WEAPONS

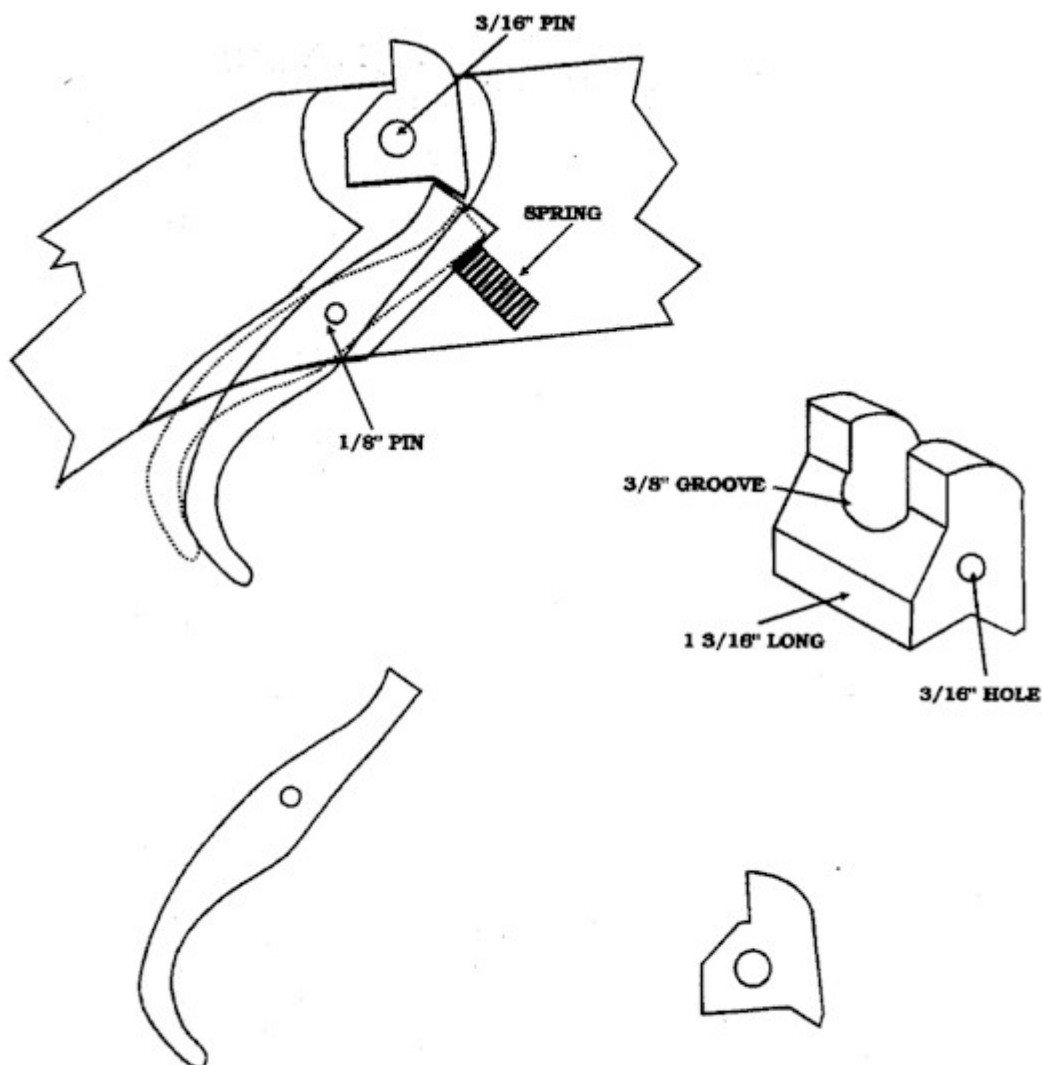

SIMPLE CROSSBOW TRIGGER

The reason for making it out of cardboard, is that you can lay the trigger and lock pattern on the outside of the stock and check it to see if everything lines up. Where you marked the pinhole, you will stick a heavy pin through it and stick it into the wood. Now you can pull on the cardboard trigger and make any adjustment on the lock or trigger. When you have everything adjusted to your satisfaction, then take a small center punch and deepen the pin mark. Then drill the 3/16-inch pinhole through the stock for both the trigger and lock.

After you have cut out the trigger and lock, drilled the 3/16 hole in both the trigger and long, use a file and emery cloth to shape and finish them smooth. After finishing them, set them into place in the stock and work them to be sure they are fitted right.

THE CONSTRUCTION OF CROSS BOWS & OTHER WEAPONS

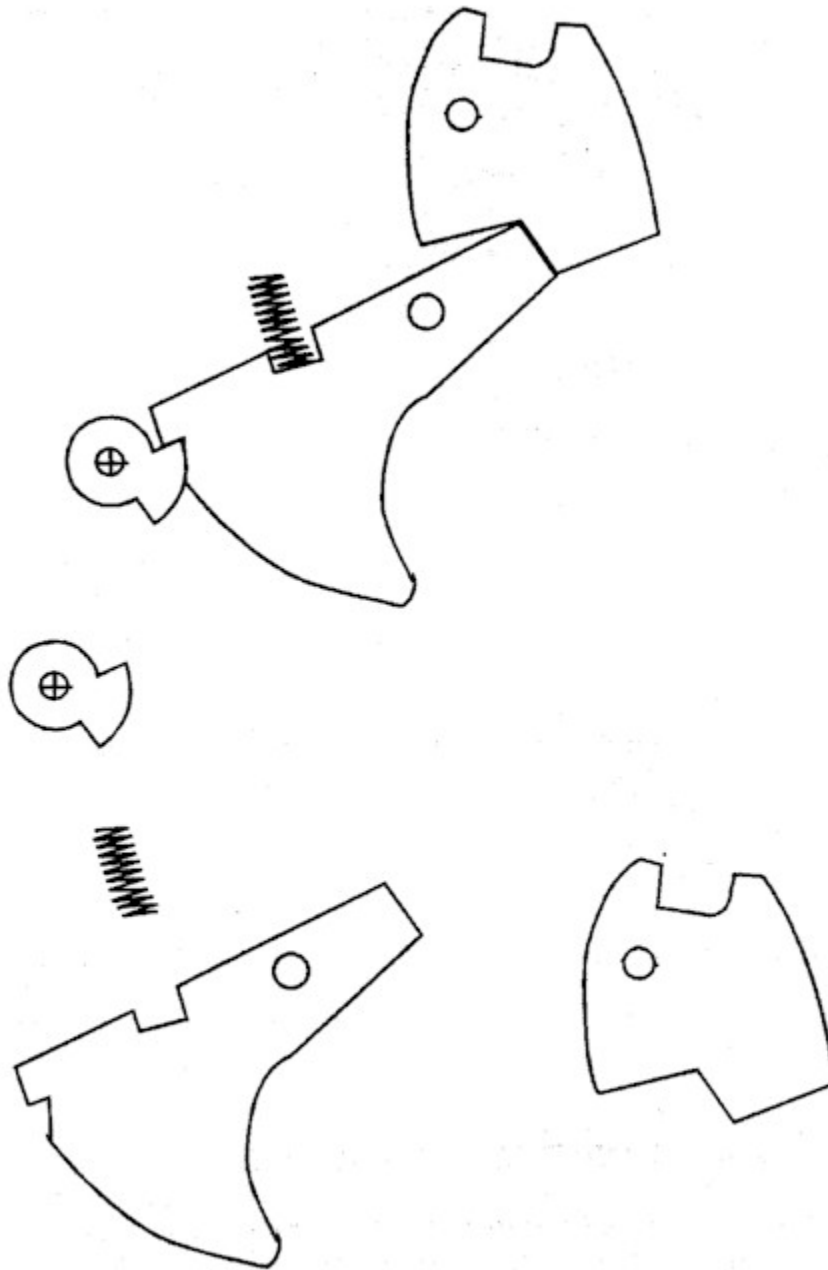

MODERN TRIGGER AND LATCH WITH SAFETY CATCH

THE CONSTRUCTION OF CROSS BOWS & OTHER WEAPONS

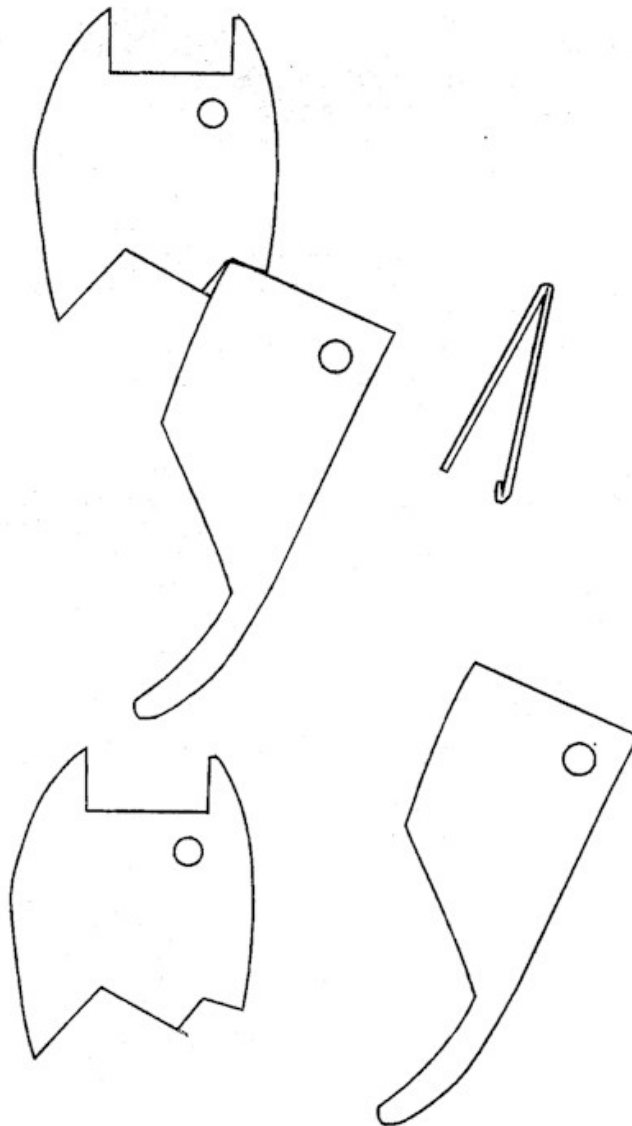

ALUMINUM TRIGGER AND LATCH

THE CONSTRUCTION OF CROSS BOWS & OTHER WEAPONS

MAKING A PISTOL CROSSBOW

You make the pistol crossbow much the same as the full size crossbow. You start with a 3/4 inch thick piece of hardwood, 24 inches long by eight inches deep. If you prefer, you can get several pieces of veneer and laminate this stock as you would on the full-length stocks.

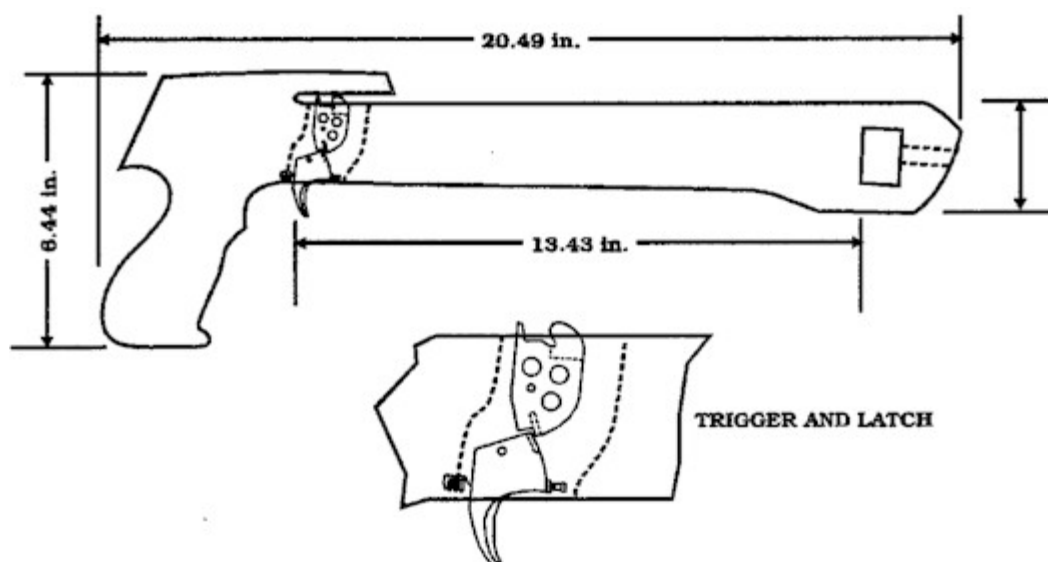

PISTOL CROSSBOW STOCK

Draw out the pattern on a piece of cardboard, then cut it out and transfer it to the wood that you are going to use for the stock. The actual length that I show for the stock is 20-1/2 inches long. You can change the pistol grip area to whatever shape or style that you prefer. I would leave the prod slot until last, or until you choose what type of prod you are going to use. After tracing the outline on the 24-inch plank, you can cut it out.

It would be much easier if you can find a band saw to use as several curves would be difficult to cut without a band saw, however a saber saw, or jig saw will work satisfactory.

If you are planning to laminate the stock together, try to use the thinner veneer so you can form the arrow groove or the channel when you glue the pieces together. If you are laminating the stock, start with 3, 3/8 inch boards 25 X 8 X 3/8 inch, and trace the pattern on each one. After marking them out, cut each to shape, following the lines very closely. Now, you will take the cardboard pattern and mark out the cutout for the trigger and release, also mark down from the top where the arrow groove will be 1/2 inch. Take 12-inch ruler and mark a straight line from the fore end of the stock to the latch cutout. Take a pair of scissors and remove that half-inch from the pattern.

While you are cutting the pattern, cut out the area that you marked for the trigger and release. Once you have the pattern cut out, lay it on the centerboard and mark the board where you cut out the place for the trigger and release area. Be very careful to line up the pattern exactly

THE CONSTRUCTION OF CROSS BOWS & OTHER WEAPONS

to the edges of the stock. Now cut out trigger area, and the 1/2-inch that you marked on the board. If you are planning to use the thinner veneer, you will need enough veneer to end up with the 3/4-inch thickness for the stock. (See the chapter on laminating stocks)

If you can, use a band saw to cut the stock as several curves would be difficult to cut without a band saw, however a saber saw, or jig saw will work satisfactory. If you are planning to laminate the stock together, try to use several pieces of the thinner veneer so you can form the arrow groove or the channel when you glue the pieces together.

The trigger and release are made of 3/8-inch aluminum or brass. In the chapter on crossbow locks there will be a detailed drawing of this release and triggers as well other types of triggers and releases. The drawings will usually be too large for the pistol stock, but you can scale it down to fit on a copy machine. Draw the trigger and release patterns on cardboard, mark the pin area with an X. Cut out this pattern. Follow the lines very close, as you are going to use these patterns to make sure you drill the pin holes in exactly the right place.

To do this, lay the finished pattern on the side of the stock. This is over the cutout for the trigger and release. Get two large pins, and where you marked the X=s on the pattern, push them through the cardboard exactly on the X=s. Set the cardboard trigger and release in the location you think they belong. Set the release in place first and press the pin into the wood, you will notice that you can rotate the release. Next, do the same with the trigger, moving it around until it in the proper place and works good, releasing the release when pulled.

When you have the trigger and release where you want them, tap the pins deeper into the wood. This is the location where you will drill the pins for the trigger and release. Drilling the pinholes with a very small drill first may be helpful, and then use the correct size drill to finish drilling the holes.

If you have laminated the stock, and after all the glue has set up, all the edges except the bolt groove must be rounded with a rasp or coarse file. Leave the area on the stock where the trigger and release will be flat for now.

If you have cut the stock from a solid piece of wood, you can drill out the area where the trigger and release goes, and then chisel it out to fit the trigger and release. You need to get a close fit; yet there should be no binding. You can cut the arrow groove with a router or saw.

When you have the arrow groove cut out, the top of this bolt groove must be absolutely flat and smooth. This applies to the laminated stock and the solid wood stock. Then, you screw strips of Formica or thin brass on top to give a long straight gap of 3/16-inch width. This can be slightly wider if you are using heavier bolts, and you should position them down the dead center of the stock. The smoothness of Formica makes a good surface on which the bolt and string can ride, but brass will last longer.

THE CONSTRUCTION OF CROSS BOWS & OTHER WEAPONS

TRIGGER COVER

You must also make the trigger cover carefully to prevent the string from jumping over the catch before they have released it. You make the clearance just high enough to clear the string. Cut a groove into the underside of this cover deep enough so that it will allow the arrow or bolt to slip between the groove and the cover. You can make this cover from any type of hardwood, and should be approximately 1/2 inch thick by about four inches long. It should be the same width as the stock, however the length and thickness may vary slightly according to any changes that you have made to the stock. On top of the trigger cover, you will fasten the bolt holding spring that will keep the bolt from falling off when the crossbow is pointed downward. This spring is nothing more than a thin flat spring and is made from half a normal mortise-lock spring, which you usually shape like a wide-open V.

When everything is fitted, you can cut out the opening for the prod. You cannot do this until you have a prod. Whether you make one or buy a finished bow, you will need it to cut the opening for the prod. Describing how to cut this area for the prod without knowing the type of prod you will be using will be hard. There are several types of crossbow stocks that show various ways of attaching the prod, and one will work for the type of prod you are using.

SHAPING THE STOCK

When you have the prod, trigger and release fitted, you can shape the stock. This is the fun part; all you need is a rasp, a 12-inch half-round wood file, and sandpaper from coarse to fine. Start with the coarse rasp and rough shape the stock out as close as you can to the drawing. When you have it shaped fairly well and the way you want it, finish it out with the finer half-round wood file. Any sharp edges should be rounded, and the entire surface of the stock should now be fine sanded and painted with a clear wood filler or sealer. When the filler is hard, sand it again, and apply two or three coats of clear varnish or polyurethane applied.

When you have finished with the finer file, start with the coarse sandpaper, and finish with the finer grits.

If you had everything fitted right, clamp the upper barrel in place so you can see if the barrel has enough clearance so that the ball or bolt will slide freely through it. While you have the upper barrel clamped in place, test to see if the trigger and lock are functioning properly and not binding anywhere. If everything is working right, you can glue the upper barrel to the main stock.

Finishing the stock is next, and you will need a rasp and several wood files and sandpaper in grits from coarse to fine. All the edges and corners should be rounded to make it more comfortable to handle. When you have everything rounded nicely, go over the entire stock starting with coarse grit sandpaper and ending with the fine grits.

We will not finish the stock completely right now as we need to fit the prod into place and check it out to be sure it is fitted right. I would recommend that you use a cut down fiberglass

THE CONSTRUCTION OF CROSS BOWS & OTHER WEAPONS

bow for your bullet crossbow. Refer to the chapter on fiberglass bows and how to make them. When you have the prod made, fit it into the stock and tighten the front screw to hold the prod tight. You can now string and test the prod to see if the trigger and lock are working OK. The easiest way to string the prod is to use a cocking string, but if the bow is not too strong, you can probably string it with the help of a buddy.

Once strung, pull the string back until the lock holds it back, and then place a dowel pin about four to six inches long in the barrel. Choose a place outside where you will not hurt anything and pull the trigger to release the bolt. As you pull the trigger, check to see if there is any roughness, as it should pull smoothly. If everything is working OK, then we will continue.

You can now make a trigger guard and a safety for the bullet crossbow. Refer to the drawing on how to make these, a safety is not necessary, but I recommend it as the bullet crossbow and is a powerful weapon.

You can make the trigger guard, safety, and front band from thin brass, that we show in the drawings.

I used the front band for mounting the sight on, as it is more durable than mounting the sight in the wood.

The rear sight that I used was a military rear sight taken from a Mauser rifle, but you can use whatever you like. Refer to the chapter on sights. Any type of rear sight will work if it has adjustments for windage and elevation.

In the drawings, you will see a spring-loaded pin that extends down into the barrel. The pin is a nail that is cut so that it barely extends into the barrel. It will hold the ball or bolt into place so that it does not fall from the barrel when pointing toward the ground. The nail is rounded on the end and only extends into the barrel far enough to hold the bolt, and a light flat spring provides the necessary pressure on the nail.

When you have everything working right, you can finish the stock. Refer to the chapter on finishing. There are many types of finish, but I would suggest using a polyurethane varnish for an attractive and durable finish. Before you apply this finish, go over the stock thoroughly to remove any scratches.

If you are going to use bolts instead of balls, the pile or point should be fairly heavy. You make the bolt from a birch dowel rod that is cut to four inches long. You do not have any fletching on these bolts so you have to depend on the weight of the pile to keep the ball shooting point on. You can also drill out the end of the bolt deep enough so that you can glue in a lead or steel ball. These make excellent small game bolts.

THE CONSTRUCTION OF CROSS BOWS & OTHER WEAPONS

MAKING LAMINATED STOCKS

In several chapters we talk about laminating stocks instead of using a solid piece of wood. The main advantage of using a laminated stock is that it will not warp. Also, on the inside pieces of veneer, you can make the openings for the trigger, release and barrel groove before gluing together.

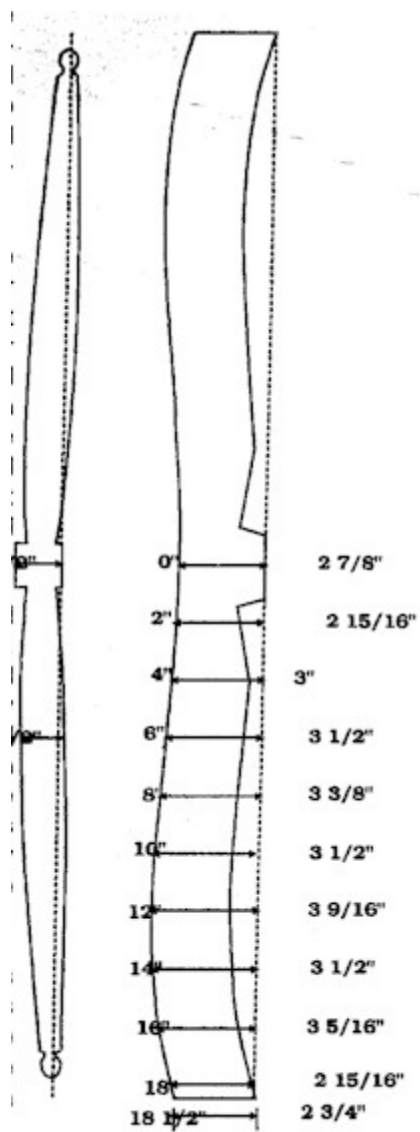

CROSSBOW PROD DIAGRAM

For appearance a good choice would be walnut, mahogany, and maple, all three are easy to work and will take a good finish. Using a combination of maple and walnut or mahogany laminated together will make a very attractive stock.

Three or five boards 3 foot long by 8 inches deep depending on their thickness to get the

THE CONSTRUCTION OF CROSS BOWS & OTHER WEAPONS

thickness that you need for the finished stock. You should first mark the shape of the stock on heavy paper; the pattern is then transferred to the boards and cut out with a band saw or coping saw. The centerboards should then be cut into the required lengths to avoid the spaces taken by the trigger mortise and the upper groove. (See the drawings on shaping the Veneer)

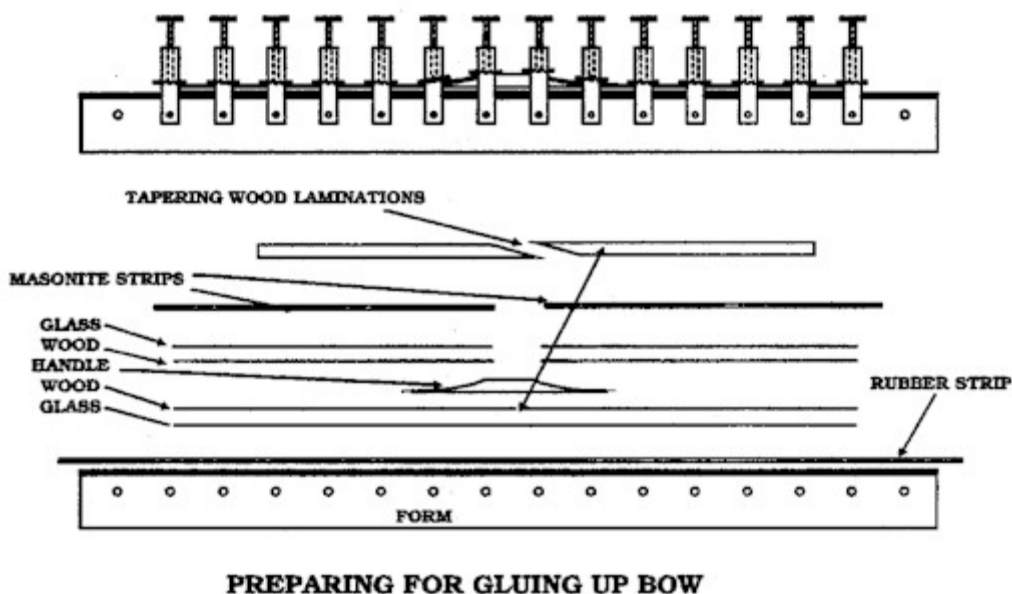

After transferring the pattern to all the pieces of veneer, cut them all out, cutting very close to the lines that you drew from the pattern. If you do not have a band saw, you can use a coping or jig saw to cut them to shape. After you have them all cut out, take the centerpiece, or pieces and lay them on a table. Take the pattern that you drew out and if you have not drawn the location for the trigger and release, do it now. When you have it drawn out, cut it out and place it on a centerpiece and trace the outline to the stock. Now, take the barrel end of the pattern, and trim off 1/2 inch of the pattern that will be the arrow groove, and trace this on the center piece.

Next, you will need to know the thickness of the trigger and release, so you will know how many veneer pieces to cut. If you are using a 3/8-inch thick trigger and sear, you might want to use 3/8-center board as then the fit would be a close fit.

The arrow groove would be 3/8 inch wide, which would be too wide for most bolts. To get around this, you fasten two thin brass or Formica strips on top of the barrel to adjust the width of the barrel for the arrow you are using.

You either fasten these strips to the barrel by screws or glue them in place.

The surfaces to be glued should be well sanded with coarse sandpaper and then brushed to remove the sanding dust. You then coat it with strong glue, such as Elmer's woodworking adhesive. Before the glue gets too tacky the various pieces of the centerboard must be placed together correctly, and the two outer boards carefully lined up to the centerpiece.

THE CONSTRUCTION OF CROSS BOWS & OTHER WEAPONS

Place the stock on paper on a flat tabletop and evenly distribute plenty of heavy weights on top to give sufficient pressure for a satisfactory glue joint. It would be better if you had four or six "C" clamps to clamp the pieces together as it would make a better job. Use some type of protection so that the clamps do not mark the wood.

If you have cut the openings for the arrow groove, trigger, and release, you want to be sure you clean glue out of the openings before the glue sets.

If you have not shaped the centerboards before gluing, you must cut them level with the outer boards when the glue is well set. Then all the edges except the bolt groove must be rounded with a rasp or coarse file. The top of this bolt groove must be perfectly flat and smooth, so any unevenness should be carefully planed flat.

Then you fasten the strips of brass or Formica to the top to give a long straight gap of 3/16-inch width or wider depending on the size of your bolts down the dead center of the barrel.

The smoothness of Formica or brass makes a good surface on which the bolt and string can ride. The sharp edges should be rounded, you should now sand the entire surface of the stock and it will be ready for finishing.

THE CONSTRUCTION OF CROSS BOWS & OTHER WEAPONS

MAKING THE STEEL BOW

The steel bow does not have the smooth shooting action of a good wood bow, and pound for pound, the wood bow will out-shoot it. Against this, the steel bow offers compactness and power, and, all things considered makes much the better crossbow. We can obtain the spring stock from a light automobile leaf spring. It will cost you two high-speed steel hacksaw blades to saw it to shape. If there is a machine shop in your area, it would be worth the money to have them saw the bow out for you on a metal cutting band saw.

23 INCH STEEL BOW						
Spring Thickness	Initial Set	Brace	Spring To Release	Pull And Thread To Hold		
				1" Wide	1 1/4" Wide	1 1/2" Wide
1/8"	2 1/4"	3 1/2"	11 1/2"	42 lbs./12	52 lbs./12	63 lbs./12
9/64"	2 1/4"	3 1/2"	11 1/2"	60 lbs./12	75 lbs./16	90 lbs./18
5/32"	2 1/4"	3 1/2"	11 1/2"	83 lbs./16	104 lbs./20	126 lbs./24
3/16"	2 1/4"	3 1/2"	11 1/2"	142 lbs./28	179 lbs./36	216 lbs./42
7/32"	2"	3"	10 1/2"	188 lbs./38	236 lbs./48	285 lbs./56
1/4"	2"	3"	10 1/2"	289 lbs./58	363 lbs./70	438 lbs./82

Metal bows should never be used for crossbow prods unless it is bound with strong self-adhesive tape to prevent jagged pieces flying about if they should break.

You can probably find a flat, or a flat automobile leaf spring at an automobile salvage yard or a farm supply outlet. What we are going to build is a steel bow for hunting that will have a pull of approximately 180 pounds at 11-1/2 inches pull.

For a bow of this weight you will need to find a leaf spring 3/16-inch thick and at least 24 inches long with a width of 1-1/2 inches wide.

Clean the grease and dirt from the spring and lay it flat on a table. Next, use a sharpened nail or needle and mark out the shape of the bow as in the drawing. Be very careful when you mark it out so that both ends will be the same width. In the center of the spring, measure and mark a line 1/4 inch from the center. Then take a square and mark a line across the spring from top to bottom. After marking, there should be a width of 1-1/2 inches at the bottom of the spring as is in the drawing. Next, from the bottom of the spring, measure up 1/4 inch on each

THE CONSTRUCTION OF CROSS BOWS & OTHER WEAPONS

side of the 1-1/2 inch width that you have just measured. On each end of the spring, measure from the top of the spring 1/2 inch down and carefully mark the spring. If the spring is a little wider than needed, it is a good idea to leave the extra metal intact at the center.

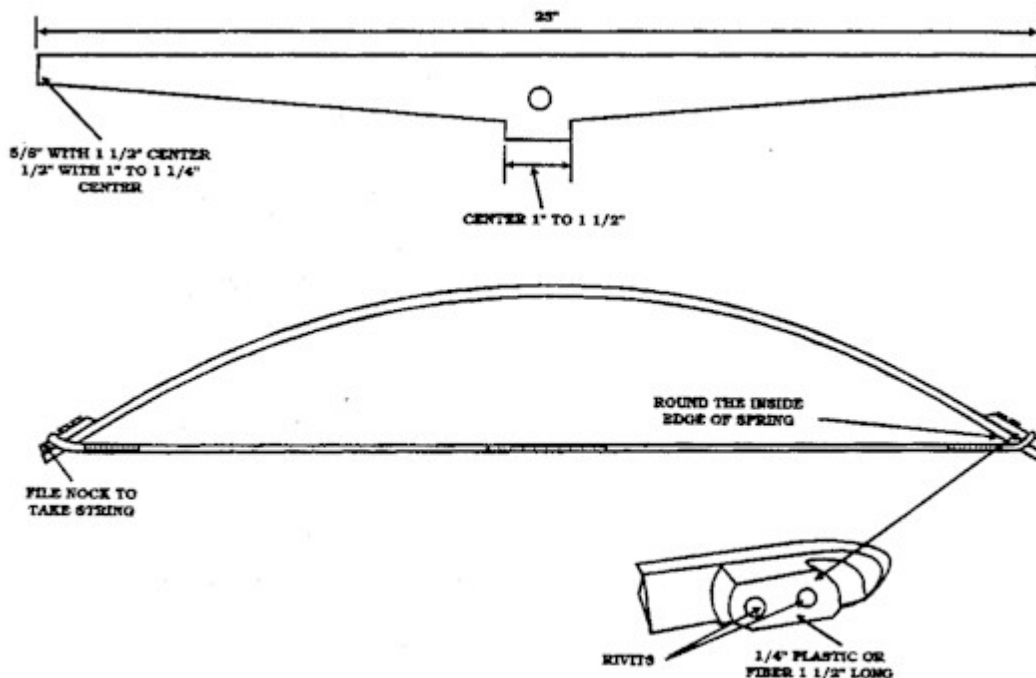

THE STEEL BOW

Take a ruler or straight edge and very carefully line it up with the 1/2 mark on the end of the spring and the 1/4-inch marks that you placed at the center. It is extremely important that we measure each end of the spring the same. The reason for this is when you cut the spring to shape both sides must measure the same. When you put a string on the bow, and brace it, both sides must bend the same. If you did not cut them the same and one side bends more than the other does, the bow will need to be tillered. What tillering means, one limb bends more than the other and you will need to remove metal from the stiff side until both limbs bend the same. On a steel bow, you may have to do quite a bit of filing until both ends bends equally. This is the reason for marking out both sides of the spring very carefully.

If you are going to cut the bow out yourself, you will need several good high-speed hacksaw blades. When you now the blade end the hack saw rotate the square fitting on the hack saw that you mount the blade to so that it will hold the blade at a 90-degree angle.

Now, clamp the spring in the vise and start cutting the spring. Saw on the outside edge of the scribed line and do your best to follow the line exactly so the edge will be fairly flat and even. Saw all the way down to the 1/4-inch mark near the center of the spring. When you get to that mark, reclamp the spring and carefully cut down to where you stopped on the 1/4-inch mark. Repeat the process on the other end of the spring.

After you have finished both sides of the spring, clamp the spring or bow in the vise. Get a

THE CONSTRUCTION OF CROSS BOWS & OTHER WEAPONS

wide flat steel file and smooth and flattened the sawed edges of the bow. When you have flattened the edges, slightly round them to eliminate the sharp edges. On the inside of the bow near the ends round the edges more so when you brace the bow, it will not cut the string. On the outside or back of the bow ends, leave them flat and do not round them. The reason for this is that now we are going to mount hard plastic material to the end of the limbs so you can cut nocks in it for the string. The plastic can be nylon 1/4 inch thick by 1-1/4 inches long. We mount these to the back of the bow limb on each end. They should be rounded and finished on the inside or the edge that is facing the center of the bow. You rivet each piece to the end of the limbs on the backside of the bow.

We cut the bow tips from sheet plastic, riveted in place and filed to take the string. What I usually do is fastened the plastic pieces to the back of the limb with Super-glue. I then drill two holes through the plastic and through the steel limbs. I then rivet them together, but before you rivet them, you must slightly countersink both sides, this includes the plastic and the steel. The rivets may be found at a hardware store, but if you cannot find any, you can use nails. The holes are drilled the same size as the rivets or nail. Put the head of the nail or rivet on the plastic side, and clip the rivet or nail off on the metal side so that it is protruding only about 1/8 inch or less. Use a small ball-peen hammer to rivet the two together.

Place the rivet head on an anvil or other hard surface and slowly flattened the ends that you clipped off with the side cutters. With the ball-peen hammer, gradually round and pull flat rivets against the bow.

After you have riveted it securely, take a small file and dress down the rivets so there will be no sharpness. Next, you will need to file in the nock recesses in the plastic for the bowstring.

We will need to backtrack now and make a bowstring, and a tiller to test the bow. Any time that you make a bow of any poundage more than 75 pounds, you should cut an additional nock in the plastic on the end of the bow on each end. These two notches or nocks are used to connect a longer bowstring so the bow can be bent enough so that we can attach the correct length bowstring. In the drawing, it shows only one notch cut into the plastic. However if you are going to use a cocking string, there will be an additional nock cut between the rivets in the plastic. This nock will be used for the regular string.

To do the following, you will need the two bowstrings and a tiller that we describe in another chapter. To brace the steel bow for tillering, you first slip the shorter bowstring over the end and past the plastic. The other end you will set the string into the nocking groove that you cut between the rivet ends the plastic end pieces. Next, take the longer string and place the loops in the outer nocks of the bow. To brace this bow for the first time, place your foot in the center of the bow. Have someone help you now, and as you pull back on the longer string, the regular or shorter string can be set in place. The steel bow will have an initial fixed set of about 2-inch deflection, and should be braced at 3-1/2 inch deflection.

The process is the same after you have the bow mounted; you will use the longer string and pull it back until it locks in the latch, then set the regular string in place. When the shooting string is in place, release the trigger and then remove the cocking string. The cocking string

THE CONSTRUCTION OF CROSS BOWS & OTHER WEAPONS

should only be long enough so we can slip the loops into place on the outer nocks.

The table shows approximately, what leaf spring steel will pull in pounds at a 14-inch draw. I recommend a 100 to 160-lb. bow. Externally heavy bows more than 300 lbs. drawing weight make nice weapons for flight or penetration shooting, but you seldom retrieve the arrow intact. It is best to make two or three bow of different weights that are all interchangeable on the same stock.

THE CONSTRUCTION OF CROSS BOWS & OTHER WEAPONS

MAKING THE FIBERGLASS HUNTING BOW

The fiberglass bow is made from a 50 or 60 pounds hunting bow that you can purchase at any sporting good store. What we want to end up with is a bow that is 80 or 90 pounds of draw weight at about 12 to 12-1/2 inches. This is accomplished by shortening the bow on each end the necessary amount to end up with an overall length of about 35 inches.

The solid fiberglass bow is a better choice or hunting because they seldom if ever break. A solid fiberglass bow is made from fiberglass-reinforced plastic it is made similar to the way concrete is made. When they make reinforced concrete, they place long steel rods in the concrete to reinforce it. Fiber glass bows are made in a similar way, fiberglass threads are embedded in liquid resin so when the resin sets the strength is much greater.

With fiberglass, the bow is extremely strong and resilient but is heavy. Fiberglass bows are much lighter in weight than steel but are much heavier than wood or laminated bows. The main disadvantage of the fiberglass bow is the combined weight tends to slow down the recovery of the bow that also effects the speed of the bolt.

Before you start on shortening a fiberglass bow, be sure to build a tiller first. The biggest problem that I encountered with fiberglass bows was that one limb always bent more than the other. Usually, the top limb was the one that had more bend, so I was unable to shorten the limbs an equal amount to get the overall length. What I ended up doing was to shorten the top limb first until both limbs bent the same. This is the reason for the tiller. When you get ready to tiller the fiberglass bow, measure the length of the bow and mark the exact center on the bow. If you are lucky, the center will be in the center of the grip.

This is where you need the center, for if it is much higher or lower in the handle section, it will be difficult to mount the bow properly in the stock. So, what I would suggest for you to do is to check out where the center is on the bow before you buy it. This will eliminate much of the cutting and fitting that you would encounter if the grip were not in the center of the bow. Most of the grips that come with fiberglass bows are made of rubber, and it should be removed. The actual fiberglass part of the grip will probably be rectangular in shape, which will make it easier to mount.

SHORTENING THE FIBERGLASS BOW

Now that you have the tiller made, string up or brace the bow. Set the bow on the one-inch dowel at the top of the tiller. Now measure the center on the string and mark it with an ink pin. Now, pull the string down to about 18 inches and hook it on the dowel pin. Next, use a tape or yardstick to measure the amount of bend there is to each limb. If you have mounted the tiller on the wall, be sure to draw the horizontal lines long enough so you can get an accurate measurement of the amount of bend on each limb.

If you find that the top limb bends more than the bottom limb, you will need to shorten the top limb to stiffen it slightly. Depending on how much extra it bends, you can probably shorten it

THE CONSTRUCTION OF CROSS BOWS & OTHER WEAPONS

by about 1 inch. When you saw the end off, you will need to file some new nocks on the limb. This is accomplished by using a small round rat-tail file. Cut the new nocks just deep enough to hold the string. When you cut the end off of the bow, the string will be too long, so you can shorten it by twisting it. You will need to make or buy a shorter string when you finally get the bow cut to length.

When you finally get both limbs to bend the same, you need to finish out the nocks on each end of the limbs so there are no sharp edges. When you cut these nocks in the limbs, make them just like the ones that were originally on the bow. File down the ends and round them to finish them out. You can use water sandpaper to get a smooth finish. When you have everything finished, you can then mount the bow into the stock.

THE CONSTRUCTION OF CROSS BOWS & OTHER WEAPONS

WOOD BOW

The bow is made of lemonwood to the approximate sections given in the table, and they recommend the 60-lb. pull weight. The 80-lb. bow is very close to the maximum stress that they can impose on lemonwood in this length of a bow. Shaping of the bow follows standard practice, flat on the front, round on the belly.

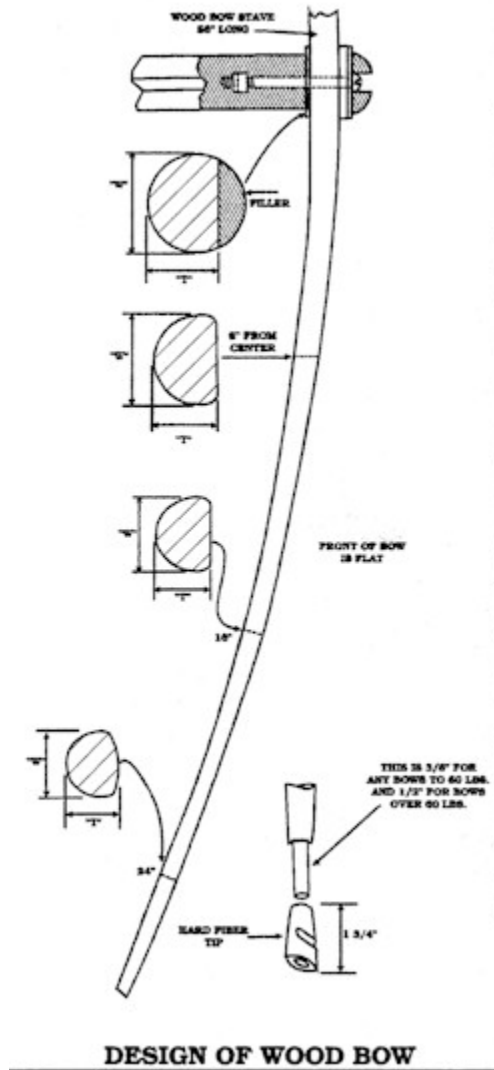

A section 2-inch long at the center is made full round by adding a filler block, as shown in Fig. 14, this section being enclosed in a steel tube.

The completed bow is fitted through the hole at the front of the stock and is fastened with a 3/16-inch bolt as shown. Note in the drawing that they tilt the bow slightly so that the string when pulled back comes to about the top of the string release.

If desired, trimming down a regular 5-ft. bow of about can make the bow of 30 lbs. drawing

THE CONSTRUCTION OF CROSS BOWS & OTHER WEAPONS

weight. When we shorten this and trim the ends down a little; it will pull about 60 lbs. at a 21-inch draw.

DIMENSIONS FOR WOOD BOWS						
STATION	40 LBS.		60 LBS.		80 LBS.	
	W	T	W	T	W	T
CENTER	1 INCH	3/4	1 INCH	13/16	1 1/16	29/32
8 INCH	15/16	21/32	15/16	11/16	1 INCH	25/32
16 INCH	13/16	9/16	27/32	19/32	29/32	11/16
24 INCH	5/8	15/32	11/16	1/2	3/4	9/16

Equally practical, a flat bow can be used instead of the stacked type shown, mounting the bow in a notch cut at the end of the stock. In any case, you must work carefully and break the bow gradually, tugging a little on the string and then releasing until the full draw is obtained.

THE CONSTRUCTION OF CROSS BOWS & OTHER WEAPONS

MAKING LAMINATED CROSSBOW PRODS

The materials used in making the bow parts of crossbows have varied in different periods of history. They used the same materials to construct the crossbow prod as they do the archery bow. Crossbow makers started using steel for their prods when that metal became available in the eighteenth century. In shooting, there was considerable danger to the shooter when the metal fatigued and broke.

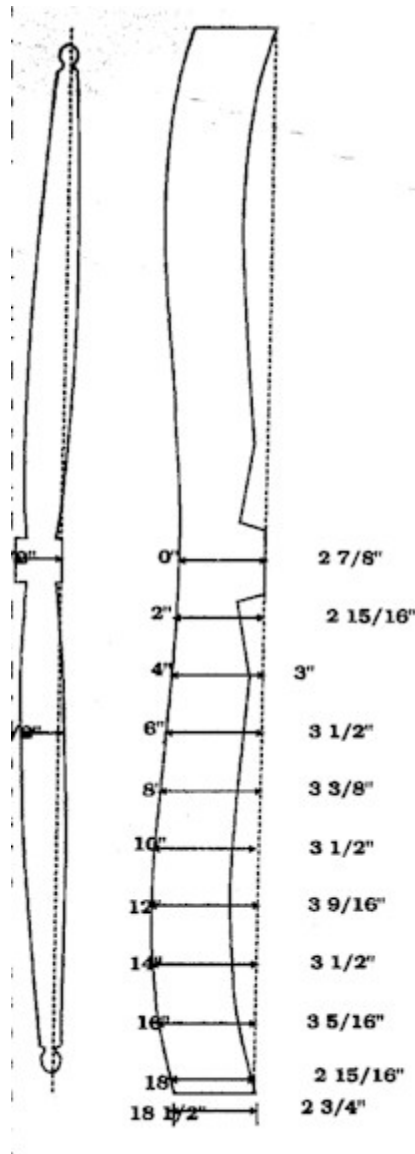

CROSSBOW PROD DIAGRAM

In China and the Far East, where crossbows appear to have been first made, bamboo would have been the most natural material for the prod.

Several years ago, aluminum alloy prods were used in place of the heavier steel prods that

THE CONSTRUCTION OF CROSS BOWS & OTHER WEAPONS

many shooters were using. At the time, they were thought to be a better bow than steel bows, as the lighter metal would recoil faster for the same weight of pull.

As they put the metal under stress with constant bending, this eventually caused the limbs to crystallize and shatter, with sometimes-dangerous results.

On composite bows the outer surfaces of both the back and front of the bow do the bulk of the work. The inside core needs only to be a strong but light material and the lighter the better.

The composite bow has a thin fiberglass strip on both sides, of a light maple wood laminations for the core.

The prod or bow of the crossbow is nothing more than a shortened long bow, and is essentially a flat bow in design but with considerable more strength.

MATERIALS

For a 35-inch bow, you will need the following materials:

You will need four Maple Laminations 24-1/2 inches long by 2-inch wide. If you want to use taper laminations, they should taper from .032 thousandths of an inch down to .015 thousandths. On the finished bow, this will give you a draw weight of about 50 pounds.

Use will also need one Handle Riser. This should be of any good hardwood, I prefer maple, and with walnut being my second choice. It should be 6-1/2 inches in length, and the riser should taper at both ends to nothing.

For the outside, you need four fiberglass Strips 24-1/2 inches by 2-inch wide. I prefer Bo-Tuff, but there is many other material that can be used. When you buy the Bo-Tuff, get the strips that measure .040 or .050 thousandths in thickness, but this depends on the weight of the finish bow that you want to make.

Clamps. (See the chapter on making bow forms)

Glue. Urac-185.

Thin Masonite battens.

Wax paper.

The average prod, has an overall finished length of 35 inches. They cut the cores from hard wood that is resin free and Maple is one of the best woods to use as core for bow laminations. In choosing the laminated, use two laminations with a maximum thickness of

THE CONSTRUCTION OF CROSS BOWS & OTHER WEAPONS

3/32 inch tapering to 1/16 inch. When you use two of these size wood laminations, you should use .050 thickness Bo-Tuff for the front and the back of the limbs.

MAKING THE FORM

On your first bow, I would recommend that you make a flat bow first. You make the bow form by laminating several pieces of plywood together to get the correct thickness. The base line, along which the inch-stations should be perfectly flat. The width of the form must be a minimum 2 inches. (Before going any farther, read the chapter on making bow forms)

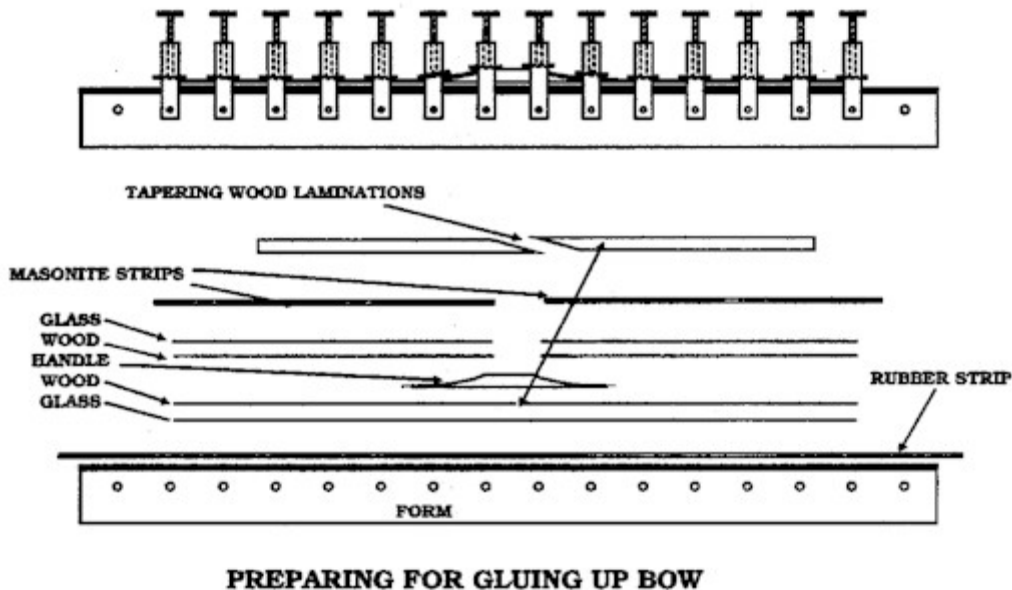

This prod allows for a limb length of 18-1/2 inches, and overall, the prod will be 35-inches in length. When it comes time to glue up the bow, you will find that the slight curvature of the two limbs will account for the extra inch at either end.

After you have cut and smoothed the form, you will be ready to begin gluing. There are two ways that you can do this. The first is to glue up your two laminations, without using the glass belly and back. When the glue is completely hardened and cured, unclamp the bow and then glue the glass to the wood, repeating the whole process. The second method is the one I prefer and always use.

I do the whole operation in one step, gluing the laminations and the glass simultaneously which I have found gives me a better job.

Besides your laminations, you will need your form, a handle riser, and some long sheets of waxed paper or plastic. You also need enough clamps so you can position one every four inches down both limbs. The chapter on making bow forms shows you how to make the clamps. You need several two inches wide, by 36 inches long Masonite strips that can be cut from 1/8 or 1/4 inch Masonite. You will need pressure blocks used with the clamps so there will be no dents from the clamps, you can make these from strips of 1/4-inch plywood or

THE CONSTRUCTION OF CROSS BOWS & OTHER WEAPONS

Masonite.

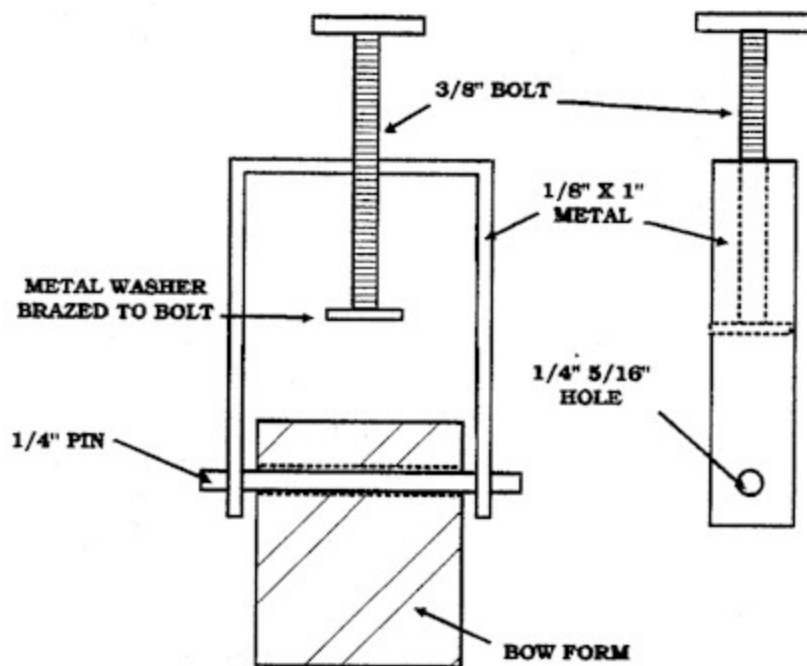

CLAMPS FOR HOLDING GLUED BOWS

Please Note - There is other newer and better glues and materials available today than the ones listed below. Check with archery suppliers. I recommend from personal experience the use of Urac-185, and Bo-Tuff glass as the best possible combination. Urac-185 requires a certain amount of heat for curing. Important, the glass that you use in the prod will govern your choice of glue. The manufacturer's instructions that come with the material will suggest the best glue for use with that particular fiberglass strips.

READY FOR GLUING

Cover the form with two layers of your wax paper or plastic, holding it in position with cellophane tape. This will keep the bow from sticking to the form when excess glue is pressed out.

Next, get the fiberglass and the laminations ready for gluing. On the back of the bow, the pair of laminations will have a 1/2 inch overlap at the center and you must taper them to form a smooth overlap. This can be done on a belt or drum sander by careful sanding and careful measuring. On the thick end of both of the laminations, you sand a 3/8-inch chamfer.

These two tapered ends must overlap and be flush for the complete 3/8 inch.

Now, sand both sides of the wood laminations with coarse sandpaper, so they will have a good gluing surface. After sanding, use a stiff brush to remove all the sanding dust.

THE CONSTRUCTION OF CROSS BOWS & OTHER WEAPONS

Assemble the glass and wood together, clamping as you go for practice, then when you are ready to glue there should not be any mistakes.

Now apply glue to the fiberglass backing and press the maple strips onto the backing, being careful to get the tapered ends lined up perfect. Next, you are ready to set the handle riser, and remember that you must feather them down to lie as smoothly as possible on the maple strips. Apply some glue to the back of the handle riser and set it in place. You must have a clamp that is deep enough so you can clamp the riser in place so it will not slip.

If you are using Urac-185, work carefully in a room with as low a temperature as possible. Urac-185 is a heat-curing adhesive, so the lower the room temperature the more time you will have to finish the work.

Apply the glue to the strips thoroughly but not too thick on one the remaining wood strip, and set it in place. Because of the handle riser, it will not lay flat. Take the other fiberglass strip and apply the glue to it and press it down on the outside maple strip. Now, take two Masonite strips and lay them on top of the glued maple and fiberglass strip. Take one of the pressure strips and place it on the end of the glued strips. Then put a clamp in place and tighten it so there is a little glue being pressed from the joints. Be careful when you tighten the clamp, as the glued joints will have a tendency to move as you apply the pressure; so keep the strips lined up to each other.

Apply your clamps now, starting riser, and working toward the ends of the limbs. Put a minimum amount of pressure on at first. When you have all the clamps in place, start at the handle and increase the pressure on each clamp in turn. It is important not to tighten the clamps more than hand pressure, otherwise you will glue starve the joints.

When you glue the strips, apply a good thin layer, since to make a perfect bond; every bit of the surface must have a good coating of the adhesive. However, do not use too much glue since it is a hard job cleaning up the excessive glue afterward. Be careful as too much pressure anywhere along the line may result in glue starvation and a bad joint. You then put the completed glued bow and form inside in the hotbox, and let it cure.

HOTBOX

This box is about 6 inches longer than the largest bow that you will make. For heating, you will need at least three, 150 watts light bulbs mounted in appropriate sockets in the top of the heat box. You should hinge the front of the heat box so it will swing up to allow you to place the glued bow and form inside for curing. When making the heat box, make sure you leave plenty of clearance for the clamps. (See the chapter on making the hotbox for complete instructions)

You will need some type of thermostat to regulate the temperature closely, as there is usually

THE CONSTRUCTION OF CROSS BOWS & OTHER WEAPONS

a limited heat range on the curing of the glue. As glue will be pressed out, the laminations should lie flat while they are in the improvised oven.

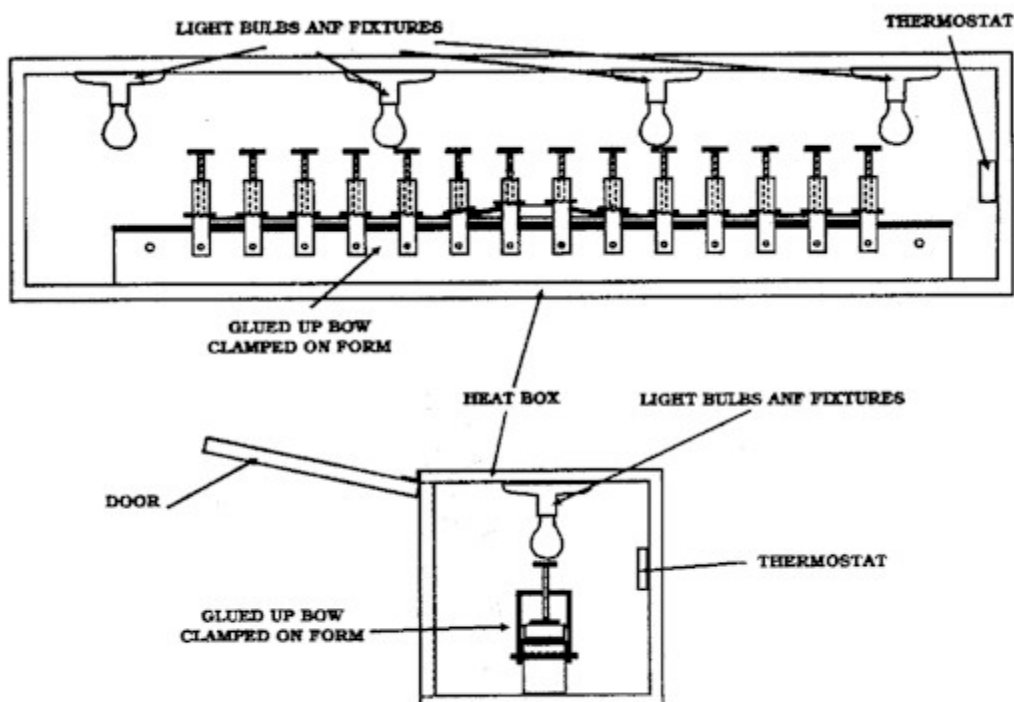

HEAT BOX FOR CURING THE GLUE

The temperature should be kept at 100° F. for five hours. When cured, you should allow the glue to cool slowly and then the laminations unclamped. The edges of the glue will be sharp, so you must handle the bow carefully.

After the glue has set, undo the clamps and all of the outer layers of Masonite are removed, exposing the rough prod. Chip any excess glue off and then the prod is roughed out, with a profile similar to the steel bow. If you have any old metal cutting blades, you can cut the profile with a saw. Important, do not cut the bow out exactly to size, since you must tiller your prod, as you would with any other bow. (See the chapter on tillering for instructions on tillering a bow)

Cut the ends of the prod square, so that 1 inch from the end, you can glue reinforcing pieces onto the forward side of the bow on each end before you cut the nock. To do this, you rough the fiberglass with coarse sandpaper, and then glue a piece of wood, 1/2 to 3/8 inch thick to the ends with an epoxy resin adhesive. Clamp these pieces under pressure for about eight hours. After the epoxy sets, round the ends and you can cut the nocks. With a small rattail file, round out the nocks and round the edges of both limbs in with a coarse file. You need to cut two sets of nocks on each end; the outside nocks are for the cocking or tillering string, and the inside nocks are for the regular or shooting string. When you cut the nocks, sand them thoroughly so no sharp or rough edges are present to wear on the string.

THE CONSTRUCTION OF CROSS BOWS & OTHER WEAPONS

If they have tapered your laminations correctly and applied equal pressures along both limbs, there should be very little work to do in tillering the bow. (See the chapter on making and using the tiller)

STRINGING THE BOW

First, you will need to make two bowstrings, one is a cocking or tillering string, and the other is the regular shooting string. (See the chapter on making bow strings) When you have the bowstrings made, put the cocking or tillering string in place on the nocking grooves that you cut on the end of the limbs. You make the cocking or tillering string the same length as the bow. You now need to tiller the bow. (Read the chapter on tillering bows for instructions on how to do it.) If you have cut out the limbs accurately, the curvature of the limbs should be very close and you should have but little work to do to finish the bow. The bow should have a draw weight of about forty to fifty pounds at a 13-inch draw.

When you fit the prod, it should fit tightly into the slot in the stock. You should glue a padding of leather or felt into the slot so the prod is held tightly, but does not touch bare wood anywhere.

In choosing the thickness of the fiberglass, if you use .050 fiberglass, you should end up with about a fifty lb. prod, but, if you are using .040 fiberglass, the pull should be between thirty and forty lbs.

THE CONSTRUCTION OF CROSS BOWS & OTHER WEAPONS

MAKING A BOW FORM

You cut the bow form according to the drawing shown. The most important thing to remember is to make sure that the form for gluing the bows is straight and not twisted, and it must be free from knots. Making the bow gluing form from plywood is better, and it is laminated together using several pieces of plywood to obtain the thickness needed.

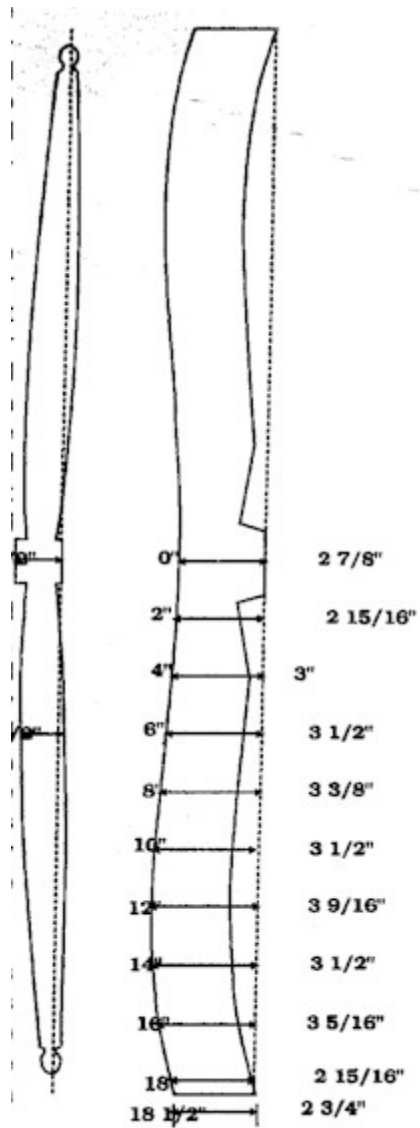

CROSSBOW PROD DIAGRAM

If you decide to make a laminated form, you would start with four, 1/2 by forty-eight by six-inch deep pieces of plywood. When you select the plywood, be especially careful that the plywood is not twisted, bent, or bowed.

THE CONSTRUCTION OF CROSS BOWS & OTHER WEAPONS

In the above paragraph, I gave you a length of 48 inches for the form length. This length can be longer or shorter, depending on the length of the bow you are planning to make. The thickness of the form, should be at least the same as the width of the bow, or slightly wider. The width (this is the depth or the height of the form) that I show is six inches, and I would not go any narrower than this.

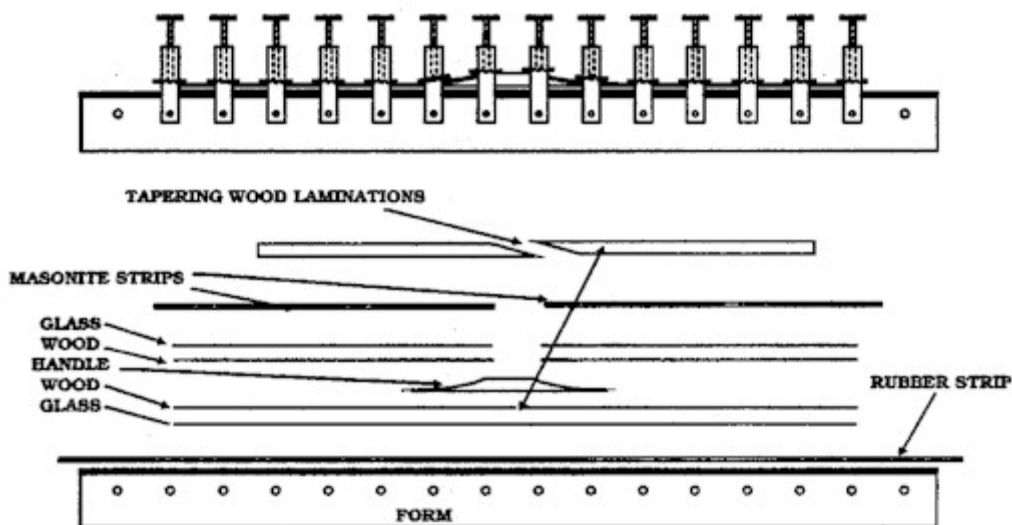

PREPARING FOR GLUING UP BOW

When you select the plywood, be sure that you do not select the type that has a waterproof coating on one side. Now, cut off from the end of the plywood, four (if you are using 1/2-inch plywood) six-inch pieces. The glue that you can use, and works well for gluing up the forms is Elmer's glue.

To glue the form, you will need eight or 10 Tuesday AC clamps. Smear on a layer of Elmers glue on one board and spread it out evenly. Next, put a board on top of the board that you put the glue on. Press it down snugly, and then apply glue to this board. Repeat the process until you have all the boards glued and in place. Start clamping the boards together now, but be careful that they do not slide around as you tighten the "C" clamp.

Clamp the plywood boards evenly all the way around the form, and then let it dry over night. After it has set, I would suggest that you run this completed board through a table saw to square up the edges. When you cut out the shape of the bow form, it must be exactly square to the form with no twist, dips, or humps on the surface of the form. This will take a little time to get it everything squared and trued. What I usually do on recurve bow forms is to glue a 1/8 by two inch wide piece of Masonite to the top of the form. This helps to level out any low places and the form. The form has to be exactly square to the sides throughout the length of the form, for if it is not, the bow limbs will be placed under much stress and will probably break in a short time.

THE CONSTRUCTION OF CROSS BOWS & OTHER WEAPONS

You can make the bow form with about any type of shape or style, but I would recommend that on your first one common make it a flat bow.

THE CONSTRUCTION OF CROSS BOWS & OTHER WEAPONS

MAKING THE CLAMPS

You will also need eighteen to twenty-four clamps when you start gluing the bow. These clamps are easy to make if you have some type of vice to hold the clamp when bending it. The clamp is made of 1/8 by 1-inch metal that you can purchase at a lumber or hardware store. You will cut eighteen to twenty-four pieces that are eight inches long. What I would suggest for you to do is to get a thin piece of cardboard and bend it the same as in the drawings. The reason for this, if you make the form narrower than two inches, the length will be different. When you have the cardboard shaped and the holes marked, lay it out on the metal pieces to get the length that you want.

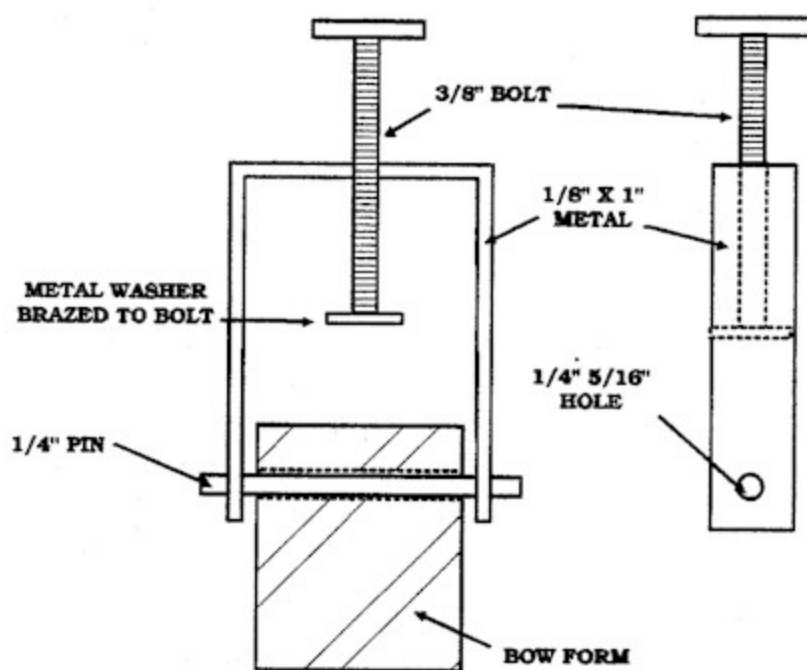

CLAMPS FOR HOLDING GLUED BOWS

After getting all the pieces cut, you can lay this cardboard pattern on top of each piece and mark where you need to drill the holes. The center hole that has the 3/8-inch bolt screwed in for the clamp, you drill out with a 5/16-inch drill and then tap it for a 3/8-inch bolt.

In the drawing, it shows a metal washer brazed to the end of the 3/8-inch bolt. Doing this is not necessary but it makes the clamp easier to use. The 1/4-inch pin is an unthreaded steel rod that you can also purchase at a hardware store.

On the bow form, mark evenly spaced holes the entire length of the form, and then drill them with a 5/16-inch drill.

If you wanted to glue a piece of Masonite on top of the form, cut out four, and used the other

THE CONSTRUCTION OF CROSS BOWS & OTHER WEAPONS

three for holding down the piece that you are gluing to the form. Do not clamp any tighter than is necessary to pull the Masonite piece down flat. Let everything dry over night and the form is ready to use. When you use the form, lay a thin piece of plastic over the top to keep glue from sticking to the form.

THE CONSTRUCTION OF CROSS BOWS & OTHER WEAPONS

MAKING A HOTBOX

If you are going to laminate bow limb, you will need a hotbox to cure out the glue. There are new glues available today that may not require the use of a hotbox. The glue that I used for years was Urac-185, and it served me very well.

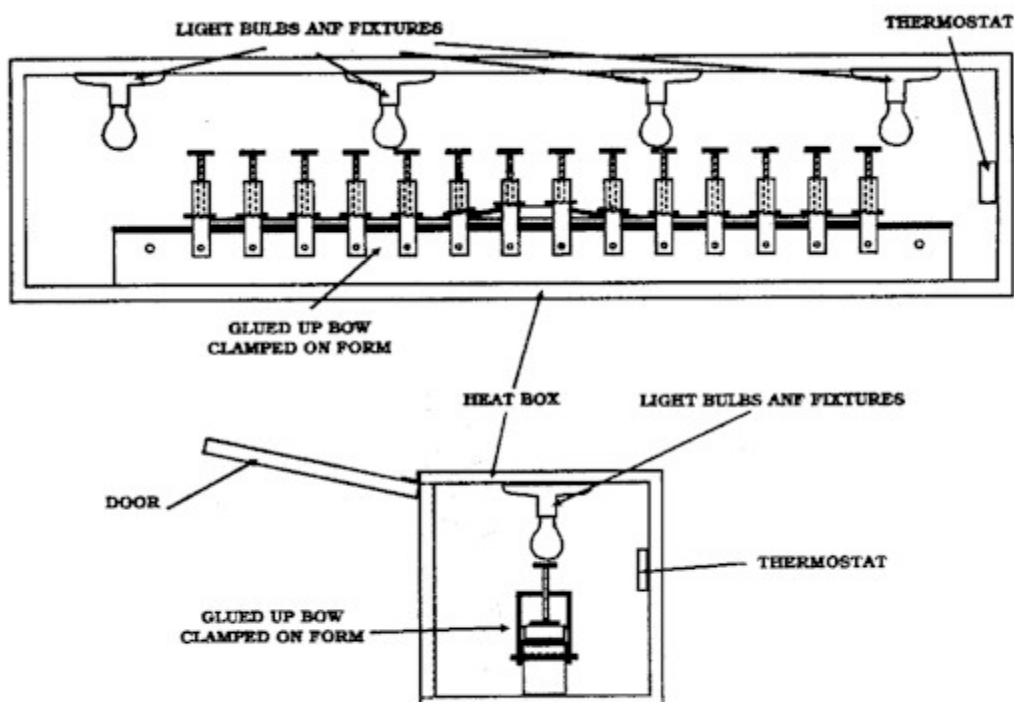

HEAT BOX FOR CURING THE GLUE

When you make the hotbox, make it long enough for your longest bow that you plan to make. This box is about 6 inches longer than the largest bow that you will make. I made the frame for the hotbox from 1 by 2 pine and covered it with 1/8 inch Masonite. In the top, I ran a 1 by 6 board full length of the hotbox. I mounted the porcelain light sockets on the two by six; refer to the drawing or further explanation. The bottom of the hotbox was a two by twelve by one-inch pine board, and I covered it with plastic to keep any glue that dripped from the bows from sticking the form to the bottom. In the front, I had a door that was the same length as the hotbox, and hinged it at the top, but you might find it more convenient to hinge the door at the bottom.

Before putting the hotbox together, line all the sides, ends, and top with aluminum foil. What the aluminum foil does, is to reflect the heat from the 150-watt bulbs evenly throughout the box.

For heating, you will need at least three, but preferably four 150 watts light bulbs mounted in the porcelain sockets in the top of the heat box.

THE CONSTRUCTION OF CROSS BOWS & OTHER WEAPONS

When making the heat box, make sure you leave plenty of clearance for the clamps.

You will need some type of thermostat to regulate the temperature closely, as there is usually a limited heat range on the curing of the glue. I have found that a wall thermostat works real well for controlling the temperature in the hotbox. As glue will be pressed out, the laminations should lie flat while they are in the improvised oven. The temperature should be kept at 100° F. for five hours.

If you use a different type of glue, the curing temperature may be different than used with Urac-185, so read the directions carefully.

THE CONSTRUCTION OF CROSS BOWS & OTHER WEAPONS

ANCHORING THE PROD

To reduce friction on the string, the best way to anchor the prod would be to have the bolt shooting through the center of the prod. This would not be practical, as it would weaken the center of the prod. However, on metal bows, by reinforcing the center section you could use this method. It would make it extremely difficult to fix the prod in the stock. When you mount the prod, you must mount it below the top level of the stock. You should mount it at an angle so when the string is at rest, it does not bear so hard on the stock that it causes friction. The angle is very important, if the prod was set at too much of an angle it would lift the bolt out of the groove while it was driving it forward.

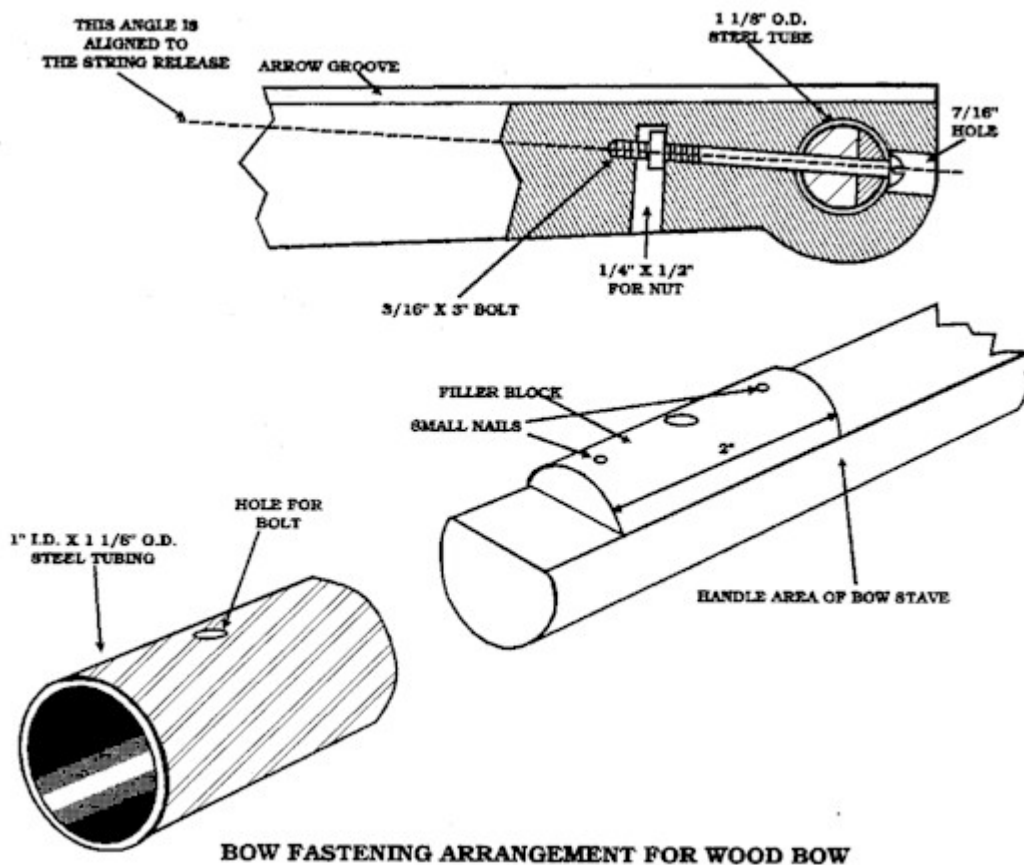

When metal was used in the construction of crossbows, metal side plates began to be used. They called them bow irons and were fixed onto the side of the stock. They used a metal adjusting screw to make it possible to fasten the various thickness of steel prods according to the strength needed. When mounted this way, stirrups can be added to aid cocking to the bow-irons.

I have seen some lower priced crossbows that have the steel prods screwed into the front end of the stock, and they work well for hunting bows. I believe the best method of mounting the prod is to cut a slot upwards from the under part of the stock. You have to be careful not to weaken the stock by cutting into the bolt channel. With the slot cut, you then slide the prod up

THE CONSTRUCTION OF CROSS BOWS & OTHER WEAPONS

into this slot. You will need to glue leather or felt padding in the slot, so when you mount the prod in the slot, you tighten snugly so there is no movement. I prefer this method for mounting the composite prod, because the fiberglass must not rub against any hard surface causing wear.

The angle that the prod is fitted to the stock must be somewhere between the vertical and 10. However, the exact angle between those two is regulated by the length of the draw, so this angle will need to be calculated carefully. If you have a crossbow that has a draw length of about 14 inches, you cut the slot about 5" from the perpendicular. When you cut and shape the prod, keep the top edge level but you should taper the bottom edges of the limbs upwards.

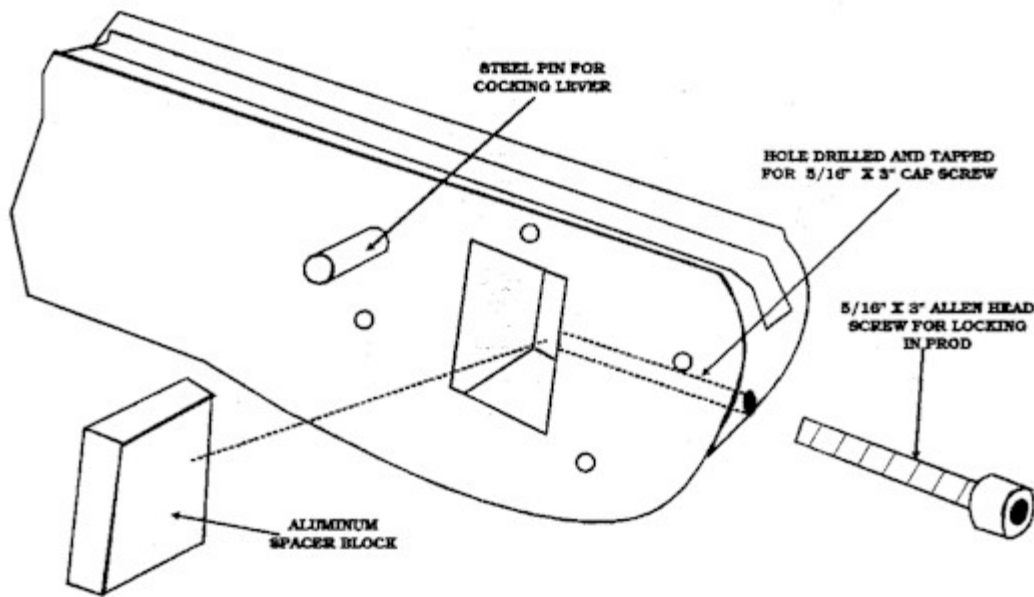

METHOD OF MOUNTING PROD

I usually make a bottom plate from hardwood to hold the prod rigid in the slot. You screw the bottom plate to the stock, and the wing nut holds it in place. I have seen some crossbows that had a slot for the prod, and had a steel bow that screwed into the end of the stock to hold the prod securely. The drawings will have several different ways of holding the prod in position, and you can choose the one that will work best for you.

When you fit the prod, it should fit tightly into the slot in the stock. Padding of leather or felt has to be glued into the slot so the prod is held tightly and does not touch bare wood anywhere.

THE CONSTRUCTION OF CROSS BOWS & OTHER WEAPONS

MAKING A SHOOTING STRING

Once you install the prod, you must string it. I would suggest you make what they call a bastard string along with the regular Dacron strings. This bowstring is longer than the shooting string and can be slipped onto the prod more easily. It is then used to draw the bow back to the cocked position so you can loop the shooting string in place. When this is done, you can release both strings with the trigger and can remove the bastard string. This is the only time that the crossbow should be dry-fired, since dry firing can break or split the prod.

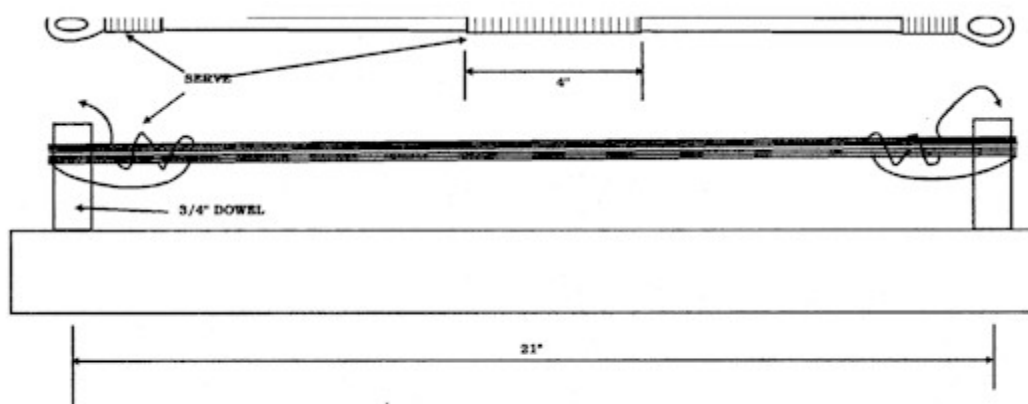

STRING MAKING JIG FOR CROSSBOWS

The string takes the most strain when the string is cocked at a full draw. When the bolt leaves the prod and the two limbs snap the string taut there is a tremendous amount of strain on the string. A 50-lb. prod can put more than 200 pounds of pressure on a string. This is important to remember when you make a string. Always allow an extra margin of strength when you make a bowstring. The disadvantage of a heavier the string is that it will slow the speed at which the bolt will travel. Tests have found that the speed of the bolt is reduced by the equivalent of adding one-third of the weight of the string to the weight of the bolt. Knowing this, you should always avoid unnecessary weight when you make the string.

The choice of material for the string is important, it must have very little stretch, and Dacron is probably the best. You might decide to try many different materials when you make a bowstring. Nylon is unsuitable, as it will stretch too much. I have tried cotton string but it does not have enough string and will usually break the first time you use it. Another material that I have used is hemp, but finding it is hard. By far the best material for bowstrings is Dacron, also known as Terylene. The easiest way to find any material that you might need is to go to an archery shop, or order a catalog from one of the archery magazines.

STRENGTH OF STRING

The strength of the complete string can be obtained by finding the breaking strain of one thread.

THE CONSTRUCTION OF CROSS BOWS & OTHER WEAPONS

Knowing this, use enough threads to make the required total breaking strain, this can usually be found with the information that comes with the spool.

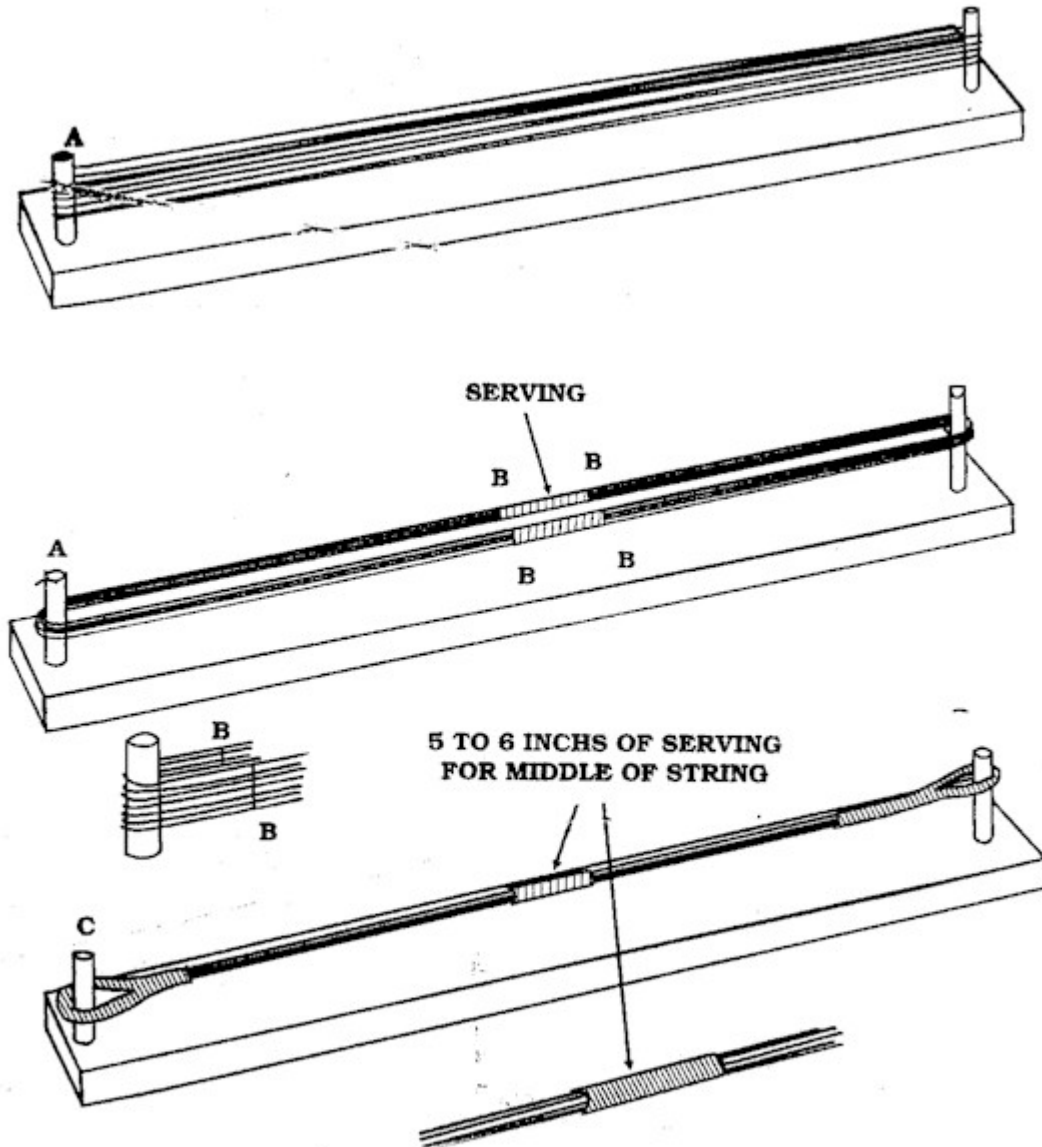

STEPS IN MAKING A BOWSTRING

When you start to make the string, the overall length of the string between the loops should be 2 to 2 1/2 inches shorter than the distance between the nocks of the prod. To make a bowstring board, you will need a two-by-four board the same length as the prod. If you have several prods, you should cut the board to the length of the longest one. In this board you drill two 1/2-inch holes for two dowel pins, 3 inches long and about 1/2 inch in diameter. We tap the 2-inch dowel pins into these holes, however if you have several prods you will need holes for the longest prod. If you have several prods, you may find it easier to use a two by six and drill the holes from the left side of the board to the right side on one end of the board. By

THE CONSTRUCTION OF CROSS BOWS & OTHER WEAPONS

doing this, the dowel pins will not interfere when you are making a longer string. On one dowel pin, loosely tie one end of the thread, and then wind round from pin to pin until you have the required number of threads (half the number on each side of the pins).

SERVING

Next, tie the two ends together, and you now have one continuous circle of thread running round the pegs. With an ink pin, make a mark on each section of the threads at the "B" line from each peg. Now, you need to slide the threads around until the marks come opposite each other at the center of the board.

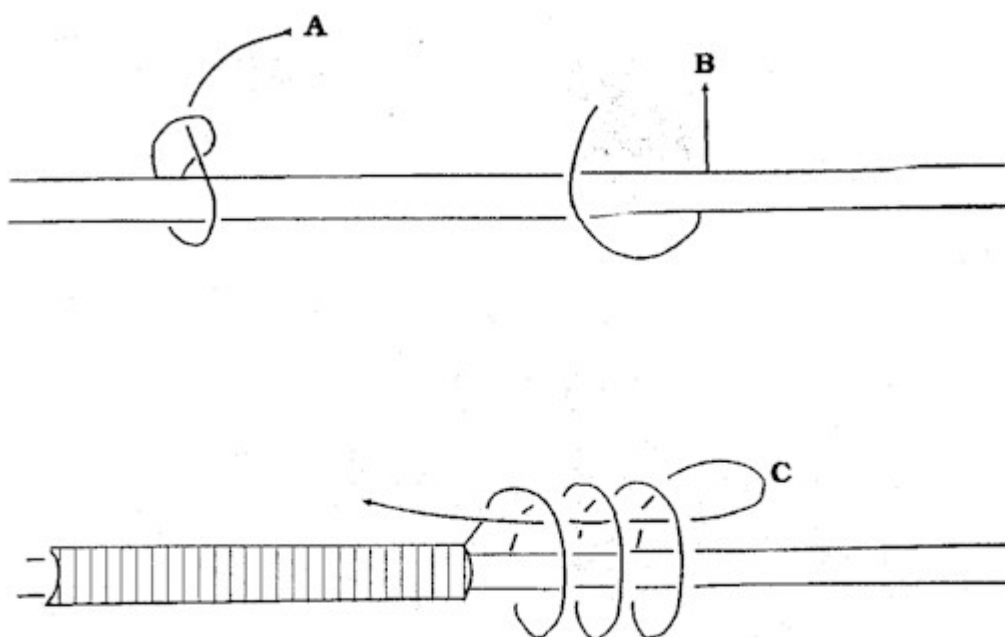

STEPS IN SERVING A BOWSTRING

The threads between these marks will become the loops to go over the nocks of the prod, so we must put on the serving between the two marks on each section. If you can find colored string, the string will look better if this serving is done with colored thread. Start wrapping the thread around the string between the marks that you have placed on the string. They sell a string server that will hold a spool of thread especially made for this purpose. As you wrap the thread around the string, be careful that you do not get any spaces between the threads as it will not look good on the finished string. After serving this area, tie the serving thread securely.

The served parts are then slid back to the pins and adjusted evenly round them. You will use the same thread as you did when serving the center portions in the above paragraph. Now serve the sections together for about 2 to 2-1/2 inches, and this will form the loops C. When done, you can take the string off the dowel pins. You should twist the finished string a few times before putting it on the prod. This type of string has fixed loops at both ends, so if you

THE CONSTRUCTION OF CROSS BOWS & OTHER WEAPONS

need to adjust the length, you twist or untwisting the string. Normally you can make an adjustment of about 1-inch in this way.

STRING FOR 23" STEEL BOWS		
PULL AND THREADS TO HOLD		
1" WIDE	1 1/4" WIDE	1 1/2" WIDE
42 LBS./12	52 LBS./12	63 LBS./12
60 LBS./12	75 LBS./16	90 LBS./18
83 LBS./16	104 LBS./20	126 LBS./24
142 LBS./28	179 LBS./36	216 LBS./42
188 LBS./38	236 LBS./48	285 LBS./56
289 LBS./56	363 LBS./70	438 LBS./82

You have probably noticed by now, there is only half the number of threads in the loops as there is at the nocking point. You are probably thinking that the nocking loops would be the weak spots and would break first. However, the breakage usually occurs at the nocking point and not at the loops.

To finish the string, rub it well with beeswax and then heat the served area to melt the beeswax into the string after we brace the prod.

To finish the bowstring, you need to serve the center of the string with strong sewing thread, and wax it good before using. I always use a different color here as this makes the string look better. To serve the string, start the serving at "A" in the drawing, and about one inch from the center when the prod is braced and continue wrapping for 2 inches. To finish the serving, pull the thread back through several loops, as at C. This serving will protect the string from being worn by the catch and the rails.

Usually, the prod will be too strong to be bent by hand when you try to fit the string in the nocks. To get around this, you can cut two extra nocks in the prod. You should cut them nearer the ends of the prod than the main nocks as described in making the metal prod. If you cut extra nocks, you must make another string long enough to fit easily into these secondary nocks.

After we have looped the main string over each limb of the prod, after it is fitted in the stock, the longer string can be fitted into the outside nocks and this string pulled back and cocked. By doing this, the prod is bent sufficiently for the main string to be fitted. Then take off the

THE CONSTRUCTION OF CROSS BOWS & OTHER WEAPONS

cocking string until it is needed later for unstringing.

THE CONSTRUCTION OF CROSS BOWS & OTHER WEAPONS

MAKING A TILLER

If you are going to make any type of bows or prods, you will need a tiller. The tiller is used to measure how far each limb bends when it is pulled back to full draw. Once you can see which limb bends more, the stiffer limb is lightened by removing material from the limb.

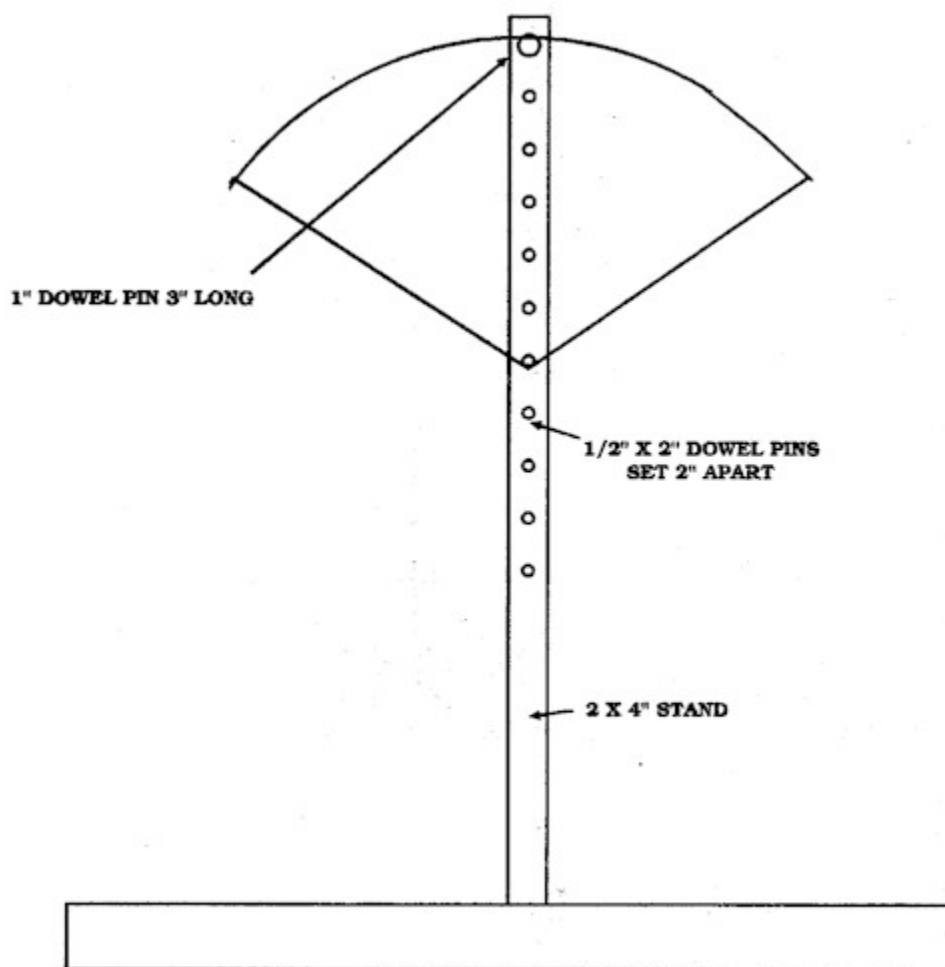

STAND FOR TILLERING THE PROD

A tiller is simple to make, and we can make it in two different ways. The easiest way is to use a two-by-four in the wall of the prods and mount wood pegs in it. The other way is to get a half sheet of 3/4-inch plywood and a two-by-four, and four feet long.

The first type of tiller I will describe first. It will probably be the most convenient type to build and use. What you will need to build this tiller is a one-inch and a 2-inch dowel rod. We require a 1-inch and a 2-inch wood drill bit to drill the holes in the two-by-four wall stud. You will also need a pulley and about 10 feet of 3/8-inch nylon rope. To go along with the pulley, you will need to find an eyebolt with wood threads that will screw into the two-by-four stud.

THE CONSTRUCTION OF CROSS BOWS & OTHER WEAPONS

We fasten the pulley to the eye screw and it is used to pull back the string on the heavier prods, and should have some type of metal hook tied to the rope.

If you have sheet rock on the wall, and I am assuming that this is in your shop or garage, so much the better. The first thing you want to do is to mark on the wall horizontal lines starting from five feet from the floor. From the first line at the top where you will drill the hole for the one-inch dowel rod, measure down every two inches and mark a horizontal line 3 foot long on the wall. Repeat the process until you reach thirty inches. These horizontal lines must be exactly square to the stud in the wall, as you need an accurate measurement of the bend in the limbs.

Next, mark a vertical line from the first mark at five feet all the way to the floor. Now you are ready to drill all the holes in the stud. Start with the one-inch drill and drill a hole two inches deep in the stud. Next change the drill to your 2-inch drill and drill all the remaining holes two inches deep. The eyebolt can now be screwed into the stud about four inches from the floor. We mount the pulley to this eyebolt with a chain or cable connector. Do not use an eyebolt any smaller than d inch as it will probably bend on the heavier prods.

Cut the one-inch dowel rod off to five inches, and the 2-inch dowels to two inches in length. Take a little bit of Elmer's glue and small it on the end of the dowel pins and drive them in the holes all the way to the bottom.

USING THE TILLER

Feed the 3/8-inch rope in the pulley and fasten the hook to the rope. Slip the main bowstring onto the prod in the second nock from the end. Take your cocking string and slip the loop on the outside nocks. Pull the d inch rope with the hook attached up to the string and hook it. Now pull the string down until you can hook it on one of the 2-inch pegs, and hook the string over it. Take the master string and set it in the inside nocks, but be sure it is hooked good. Pull the cocking string down far enough so you can release it from the peg. Then let the cocking string up until there is no pressure on it, and then remove it.

If you have marked the string in the exact center, pull it down just far enough to hook it on a peg. When you hook the string on the peg, be sure it is exactly on the mark on the string. You now measure each end of the prod to the horizontal lines that you marked on the wall. Both ends of the prod should measure the same, but if it does you will need to remove material from the stiffer limb. During testing, you will need to pull the bow or prod to the final length of the draw at which it will be used. When you have to remove material from the limbs of the prod, look very closely at the stiff limb. If most of the bend is near the handle remove the material from the outer end of the prod. If you have more bend on the outer end of the limbs on the prod, remove material closer to the center of the prod.

Measure the bend carefully, if one limb is stiffer than the other, this would cause inaccuracy and must be corrected, to check the tiller mark, a spot about mid-limb, the same distance from the center on both limbs. Now, measure the length of a line that crosses the string at

THE CONSTRUCTION OF CROSS BOWS & OTHER WEAPONS

right angles and passes through this spot. If you find that this distance from that spot to the string is shorter in one limb than the other, the result would be that this limb would be too stiff and must be lightened.

After marking this limb, take off the string and reduce the width of the limb by filing first the edge of the fiberglass and then the wood core on the lower tapering edge. Do not remove any material from the top of the limb or the surface of the glass. Reduce the width gradually for the whole length of the one limb and repeatedly test the bow on the tiller until both limbs bend equally. When you have both limbs bending the same, sand the edges, not the surface of the fiberglass, and apply two coats of clear varnish to the completed bow.

Tillering in most cases is a time-consuming operation, but is extremely important to get it right. If we have not tillered both limbs out the same, the string will not pull straight when fired and will end up throwing the bolt off.

THE CONSTRUCTION OF CROSS BOWS & OTHER WEAPONS

COCKING LEVERS

On bows up to 100 Lbs., the hand can set the drawing weight of the bow, over this weight using a cocking lever is necessary. Fig. 28 shows the construction and dimensions of a cocking lever for 112 inch draw. The galvanized wire hook, which slips under the bow, will automatically assume a bent position the first time it is used. If the release is set slightly forward, the trigger will cock automatically when the string engages the rear prong of the release.

(Below)

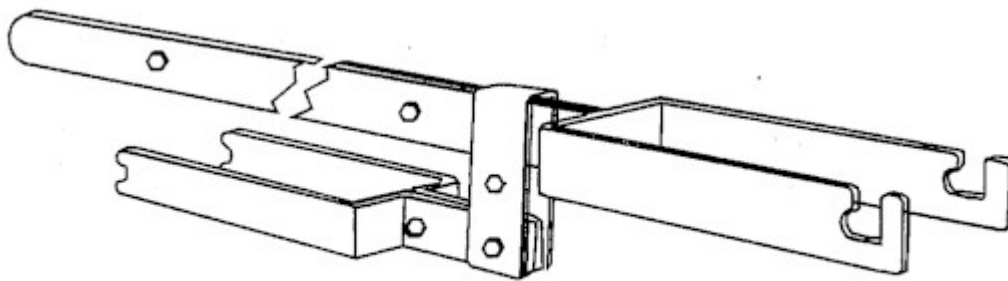

METAL COCKING LEVER

THE CONSTRUCTION OF CROSS BOWS & OTHER WEAPONS

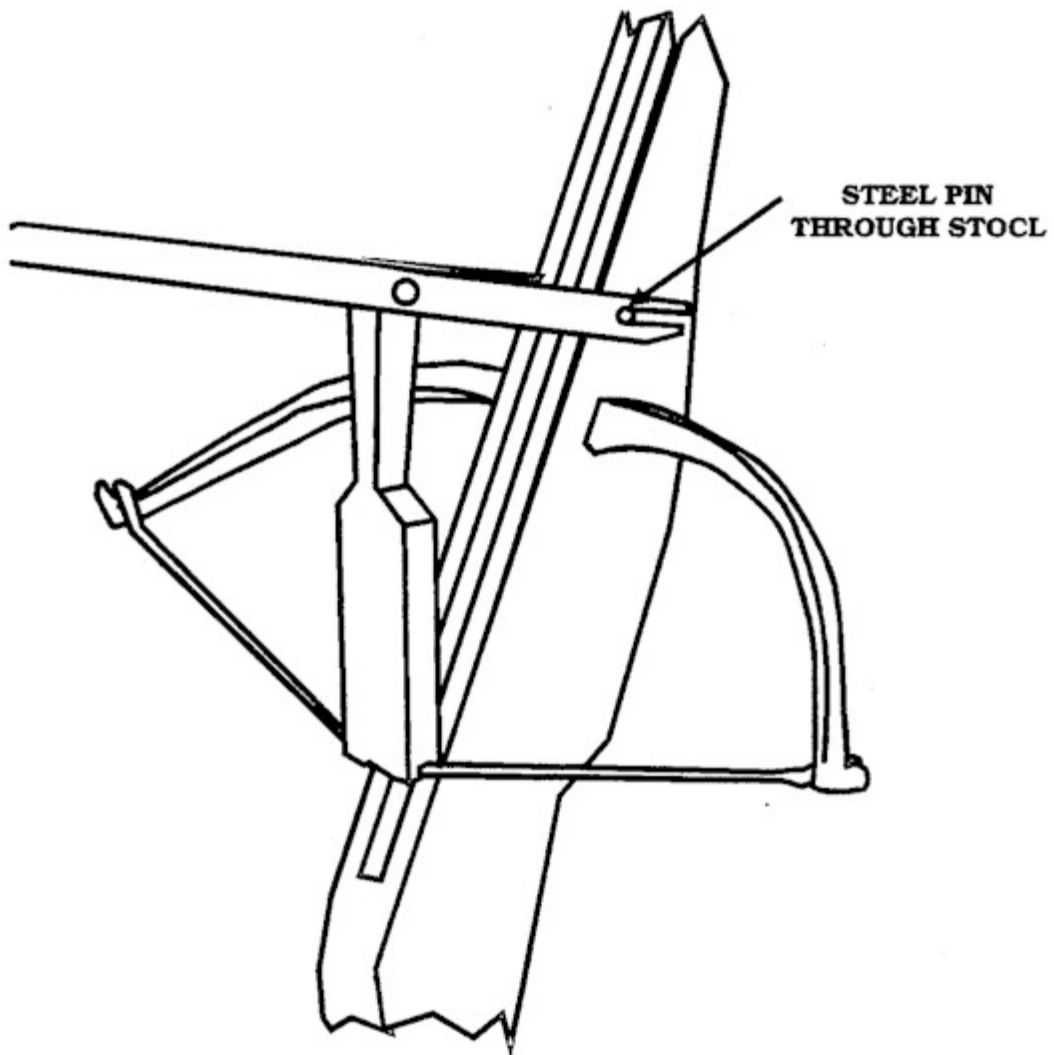

ANOTHER TYPE OF COCKING LEVER

THE CONSTRUCTION OF CROSS BOWS & OTHER WEAPONS

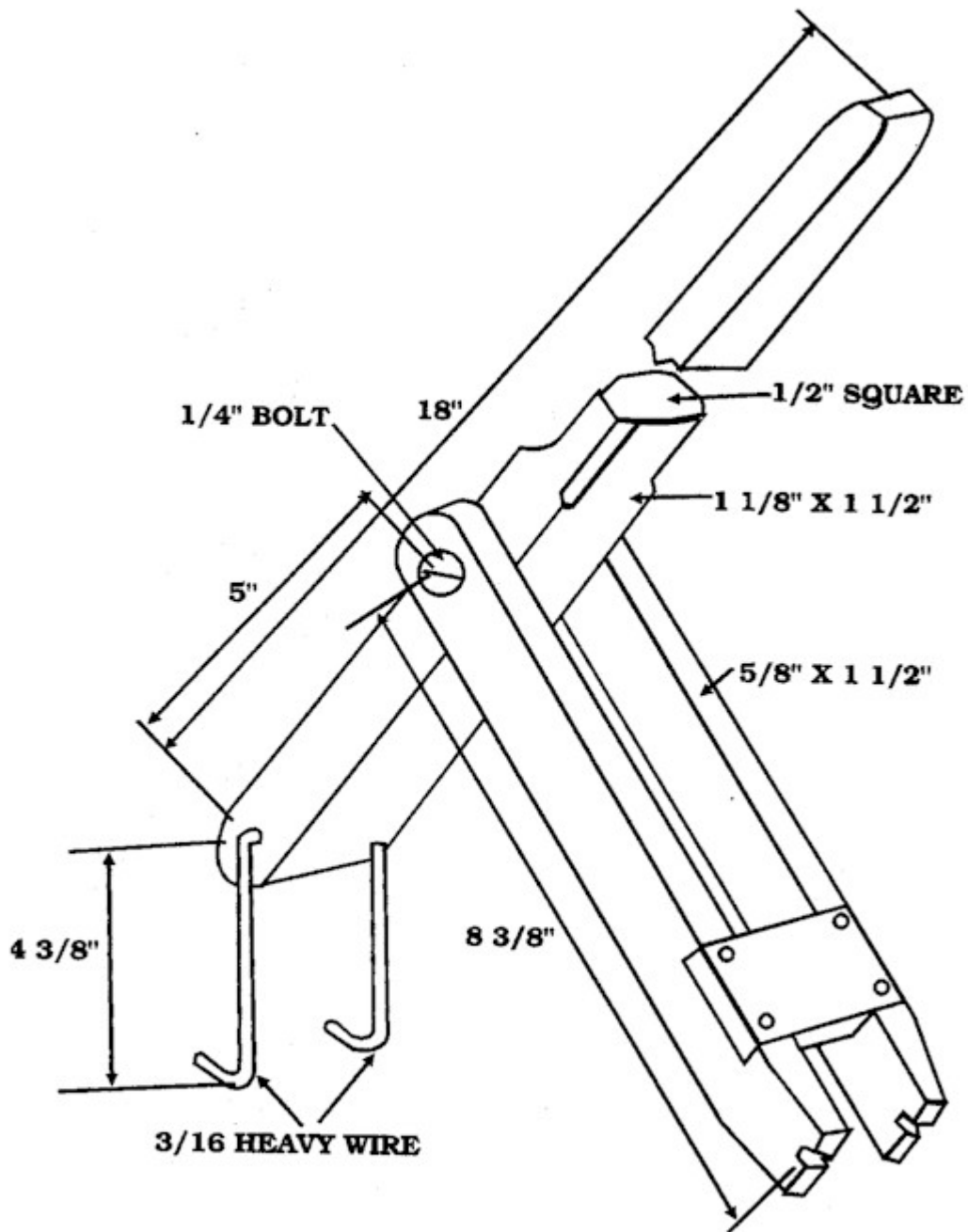

COCKING LEVER

THE CONSTRUCTION OF CROSS BOWS & OTHER WEAPONS

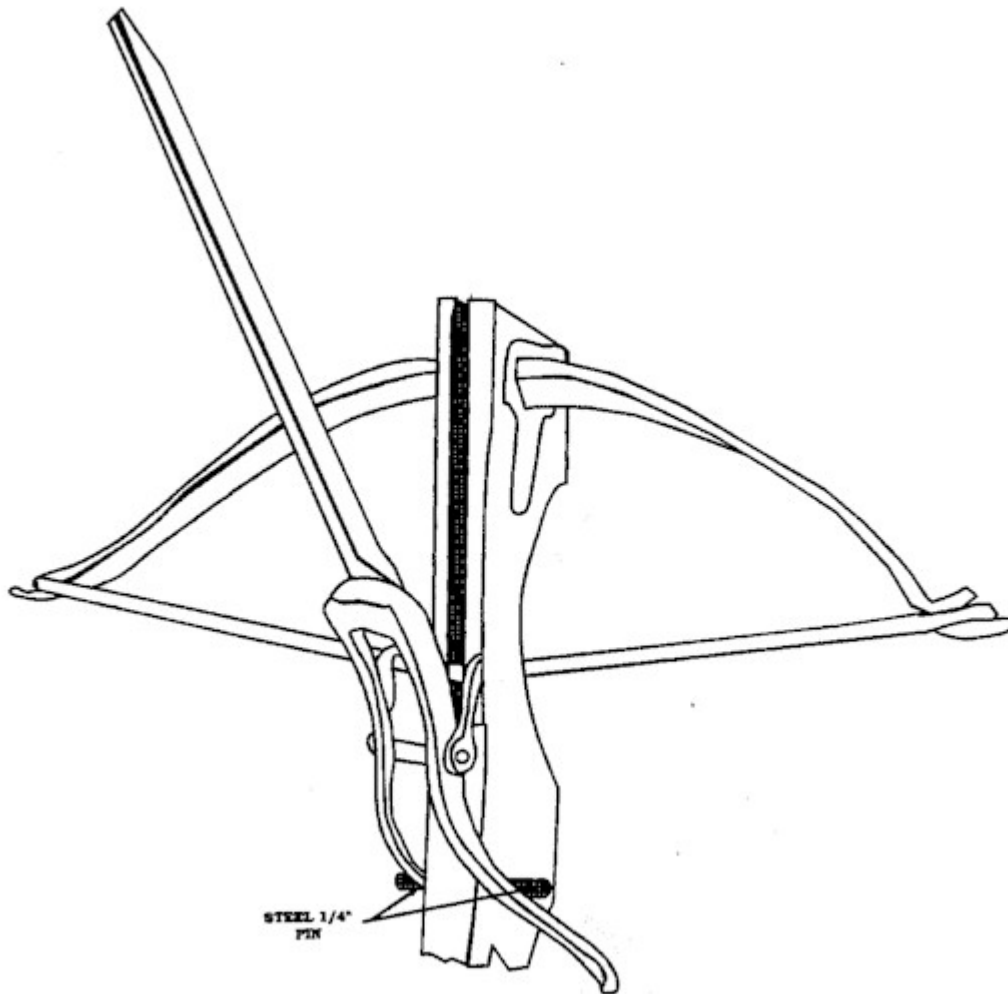

ANOTHER STYLE OF COCKING LEVER

THE CONSTRUCTION OF CROSS BOWS & OTHER WEAPONS

THE SIGHT

Your crossbow should be ready to and the only thing which you will need to add is some form of sight. A rifle sight may be adapted for use with a crossbow, but you can equally well make your own.

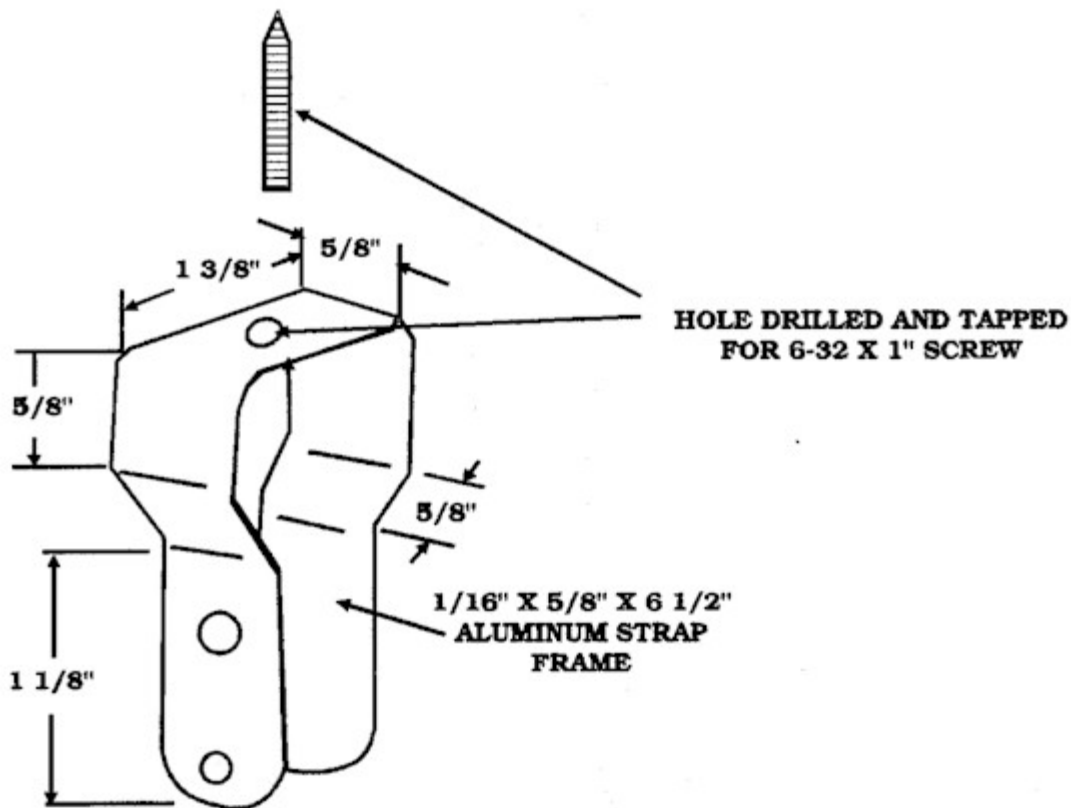

FRONT SIGHT SETUP

Your sight will consist of a front post, which is fixed, and a rear, adjustable section. For the front post, take a piece of very heavy wire and cut it 23/4" long. Turn the last 3/4" at right angles to the rest. Now, cut a thin groove on the left side of your barrel, one inch in from the end, or the vertical. It should be just wide enough to accommodate your sight wire. A thin metal strip, glued over this groove, will serve to keep the post in position. The tip of the right angle Am should now be directly over the center of your arrow slide in the barrel. Minor adjustments are made later.

The rear sight consists of a thin strip of plastic approximately eight inches long and 1/2"

THE CONSTRUCTION OF CROSS BOWS & OTHER WEAPONS

wide, a thin piece of threaded brass and a brass track. The track is fixed to the right hand side of the barrel, just behind the latch, on the vertical. Slip the plastic strip into this track and crimp the track so that the strip will move up and down, but without slipping once it is positioned. Remove the strip and bore a small hole through it, which will receive your threaded brass, on the horizontal. With the strip in the slot or track and the brass threaded into the strip you will have a rear sight which permits of both horizontal and vertical adjustment.

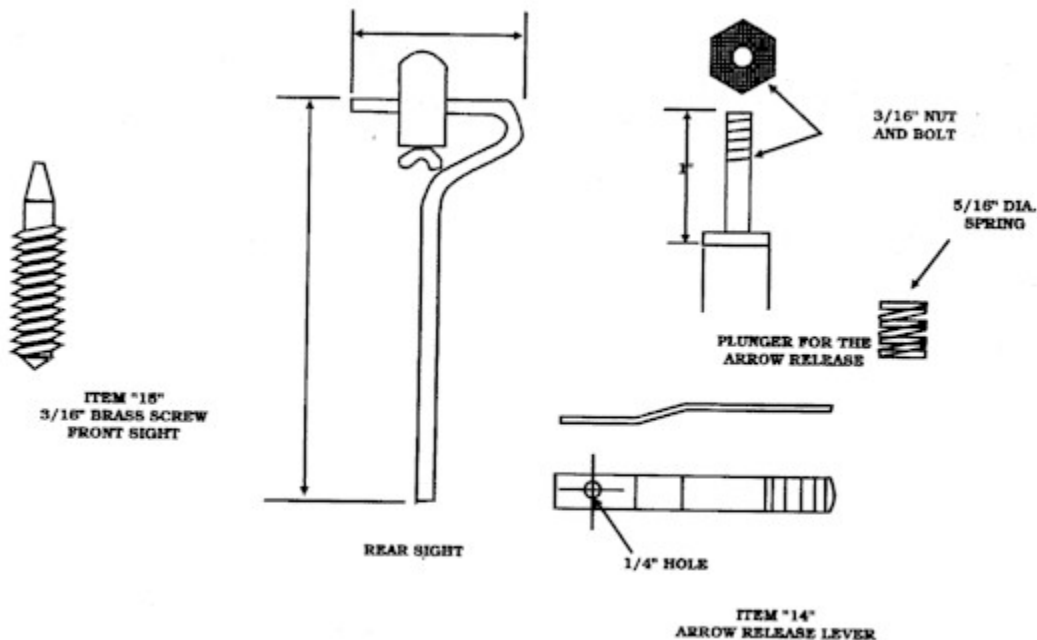

The rear sight must have some means of considerable adjustment vertically and also a slight adjustment laterally, for windage. A simple way of doing this is to provide a metal tube about 4 inch long and 5/16 in inch diameter. If one end is plugged with solder a small hole can be drilled in it to take a screw to fix the V sight. This can be made of 5/8 inch mild steel strip about 5/16 in wide. You can bend this strip in half at right angles, and then you can drill and counter-sink one part to take the set screw, while a 1/16 inch deep hacksaw-cut in the dead center of the other part and filing it smooth, will make a good rear sight similar to the modern target pistol. If a V is preferred this can be cut with a small triangular file.

A hole just wide enough to take the rear sight tube must be drilled in front of the rear screw of the catch cover. This hole should be drilled through the catch cover and the stock for about 3 1/2 inches. To fasten this rear sight tube at the required height a set screw with a knurled head should be screwed through a hole in the side of the stock.

To finish off the sight, a flat black paint is best for front and back sights to avoid highlights when aiming. The shoulders of the back sight can now be locked with the set screw at about 2 1/2 inches from the level of the catch cover.

Should there be a certain amount of wind drift the back sight can be locked slightly to the right or left without the aperture closing completely. If you prefer a more accurate sight, a telescopic sight can be mounted with a special base.

THE CONSTRUCTION OF CROSS BOWS & OTHER WEAPONS

Another type of front sight is a piece of 1/16" X 5/8" X 6 1/2° strap aluminum bent into an open frame configuration so the bolt can pass through it. It's fastened to the top of the fore stock with two No. 6 X -1 /4°, machine screws, and a short cap screw locked through its crown serves as a bead. You can make an excellent sighting post by simply drilling and tapping a hole at the top of the receiver to accept a 6-32 socket-head screw about 1 -1/2" in length. This can then be adjusted up or down for sighting.

THE CONSTRUCTION OF CROSS BOWS & OTHER WEAPONS

BOLTS

A bolt must be as straight as possible and a set of six or more bolts for target shooting should be as closely matched in weight, spine (springiness), and balance. To obtain these requirements to perfection takes the professional fletcher much time and skill. Nevertheless, with care amateurs can produce quite satisfactory bolts.

The easiest way to make a serviceable bolt is to obtain straight birch or good dowel rod $\frac{5}{16}$ inches in diameter from a lumberyard. They do not cost much and the straightest and roundest should be chosen. If they are slightly bent, they can usually be straightened easily, although sometimes we will use heat to help straighten it. After cutting the rod to the correct length, say twelve to 18-inch, rub it smooth with sandpaper. Rough edges should be cleaned and the end of the shaft rubbed with sandpaper.

MAKING THE BOLTS

We can make a very good brass pile (point for target shooting) quite simply from $\frac{5}{16}$ -inch outside diameter brass tubing of twenty-six gauge. It has a short length of $\frac{9}{32}$ -inch brass rod sweated into the front end with solder. Cut a one-inch length of tubing and a $\frac{1}{2}$ -inch length of rod. After cleaning carefully with emery cloth to obtain a bright metal surface on both metal parts, smear them with flux. Then, heat it with a propane torch, and when they are sufficiently hot, coat the rod with solder. Before the solder cools, insert two thirds of the rod into the tube and leave to cool. Most Archery shops will have ready-made points that you can install, and they will all be the same weight.

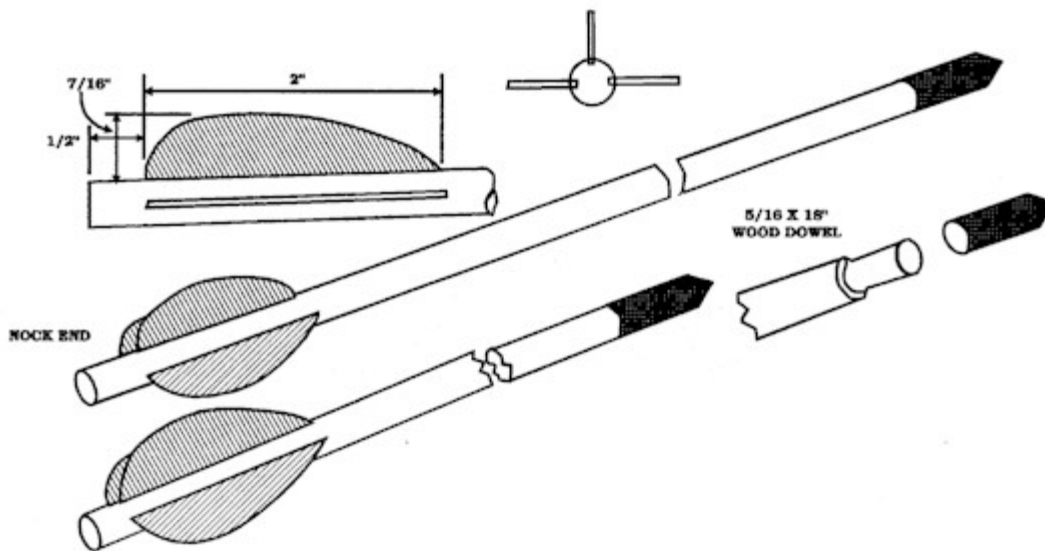

CROSS BOW BOLTS

A hand-drill or drill press can be used to spin the pile while you are filing it to a point. A threaded rod that will screw tightly into the open end of the pile is a good way, if holding the pile in the chuck of the drill while you are filing and finishing. Emery cloth or sandpaper will

THE CONSTRUCTION OF CROSS BOWS & OTHER WEAPONS

give a good finish if you use it while the pile is turning in the drill. All the piles are fitted and held on by using resin, but Epoxy will hold it better.

When the shaft has been finished to fit into the pile, put a few pieces of resin in the pile and hold it over the lighted gas torch until the resin melts, but take care not to melt the solder.

Insert the shaft all the way in and see that it is on straight before the resin cools; clean off the surplus resin and finally polish up the pile with emery cloth.

DOWEL BOLTS

They make the best wooden bolts from very well seasoned dowel rods with straight grain. The rounding of the shaft is completed with sandpaper.

FLETCHING

The bolts will now require three feathers glued on for steering purposes. This is a difficult job to do properly, for if they do not put the vanes on straight, the bolt will not fly true but will wobble. A fletching jig is the best investment for installing the vanes. One vane is known as the cock feather and is usually a different color from the other two. In shooting, this feather is placed down the groove.

The best feathers to use are stiff pinion or main feathers from the wings of turkeys or geese. They can often buy them in most archery catalogs or shops. There is a difference in the feathers of the right and left wings, so that the feather from one side must only be used on a bolt, for otherwise it will wobble in flight.

If you make your own, cut through the quill, then place a piece of feather flat on the edge of the bench. Use a flat piece of sheet steel or iron with a straight edge of a steel rule, place that on the vane, and push the quill up flush to it. With a sharp knife, pare off the quill level with the top surface of the metal plate. Still holding the feather down with the iron, shave off the surplus quill, leaving only a 1/8 inch strip as a foundation for the vane. To make sure that the feather will stand straight up on the shaft it is a good plan to grind the base by rubbing it on a piece of sandpaper placed flat on the bench.

We now stick these pieces of feather on the shaft 2 inch from the end and exactly along lines as described. Clamp the feather in the clamp that comes with the fletching jig and put a little fletching cement on the base, immediately put the feathers in position, and leave to dry for 30 min. When it is dry, remove the arrow and trim the feathers with a sharp scissors or feather burner to the shape you prefer.

The quickest and most efficient way of trimming feathers to the same shape is to use an electrically heated wire. The fletched bolt is placed in V slots cut in the sides of a box. An electric wire is part of an electric element, and is then bent to the outline of the feather shape required. This cutting wire is so placed and wired up that when we turn the bolt in the slot we

THE CONSTRUCTION OF CROSS BOWS & OTHER WEAPONS

cut each feather to the chosen shape. The wire must be at a bright red heat; wiring a two-kW electric wire in series with it may be necessary, or another type of resistance.

Paint the bolts with a unique band of colors just in front of the feathers. They call this the crestring, and in competitions, each crossbow man should have his own colors so that they can easily distinguish his bolts in the target. The crestring also helps you find your bolt while hunting. Finish the arrows with some type of waterproof finish or wax to keep them from warping.

The bolts will now require three feathers glued on for steering purposes. This is rather a difficult job to do properly, for naturally if the vanes are not put on straight the bolt will not fly true but will wobble or 'flirt'. It is wise to mark out the shaft in pencil first, as at E (Fig 15). D is a line round the shaft about 1 in (2-5 cm) from the end, and C a line 1-9/16 in (4 cm) from D, allowing for feathers 1-1/2 in long. Three lines should be drawn from C to D straight along the shaft and equal distances apart as at E. One is known as the 'cock feather' and is usually a different color from the other two. In shooting, this feather is placed down the groove.

The best feathers to use are stiff 'pinion' or main feathers from the wings of turkeys or geese. They can often be bought in stores or milliners' shops. There is a difference in the feathers of the right and left wings, so that the feather from one side only must be used on a bolt, for otherwise it will wobble in flight.

After you have cut through the quill, it is wise to soften the pieces by placing them between a folded cloth that you have wrung out in hot water. Then place a piece of feather flat on the edge of the bench, and using a flat piece of sheet steel or iron with a straight edge (e.g. a steel rule), place that on the vane and push the quill up flush to it. With a sharp knife pare off the quill level with the top surface of the metal plate. Still holding the feather down with the iron, shave off the surplus quill, leaving only a 1/8 in (3 mm) strip as a foundation for the vane. To make sure that the feather will stand straight up on the shaft it is a good plan to grind the base by rubbing it on a piece of sandpaper placed flat on the bench. A spring paperclip is useful for holding the feather while you are doing this.

These pieces of feather are now stuck on the shaft 1 in from the end and exactly along lines as described; Seccotine is the easiest glue to use. Rub a little on the base and allow it to become tacky before putting the feathers in position, then, having bound them with thread, as in the sketch, adjust them to the exact position, lying quite straight along the shaft, and leave to dry for twelve hours. When it is dry remove the thread and trim the feathers with sharp scissors or razor blade to the shape you.

The quickest and most efficient way of trimming feathers to exactly the same shape is to use an electrically heated wire. The fletched bolt is placed in V slots cut in the sides of a box. An electric wire (e.g. part of an electric element) is then bent to the outline of the feather shape required. This cutting wire is so placed and wired up that when the bolt is turned in the slot each feather is cut to the chosen shape. The wire must be at a bright red heat; it may be necessary to wire a 2 kW electric fire in series with it, or some other type of resistance.

THE CONSTRUCTION OF CROSS BOWS & OTHER WEAPONS

It is usual to paint bolts with distinctive bands of colors just in front of the feathers. This is called the 'crestring', and in competitions each crossbowman should have his own colors so that his bolts can easily be distinguished in the target.

To prevent the glue of the feathers being affected by wet or damp it is a good plan to paint between the feathers as well, from the crestring to the back end, taking care not to get paint on the feathers.

THE CONSTRUCTION OF CROSS BOWS & OTHER WEAPONS

BOOMERANGS

The Boomerang skims the surface of the ground for a distance of 250 feet or more, and then, rising like a bird in flight, it wheels and comes hurtling back to the thrower, landing almost at his feet. As you can imagine, there is real fun in making and throwing boomerangs.

This is a weapon of the Australian aborigines and other peoples, chiefly used as a missile. They take the word from the native name used by a single tribe in New South Wales. The Hopis (Moquis) of Arizona use a non-return form. The general form of both weapons is the same.

RETURN TYPE

The Australian Bushmen use acacia wood for the making of their boomerangs, but Hickory or hard maple will do very well. Do not try to make boomerangs of any type out of light, softwood.

The boomerang consists of two straight arms; the circle suggests the center of gravity and the rotation of the missile around this center when the boomerang is in flight. The return boomerangs, which may have two straight arms at an angle of from 70° to 120°. In Australia, it is always curved at an angle of 90° or more, and is usually 12" to 2 feet in span. It weighs some 8 oz.; the arms have a skew that they twist 2° or 3° from the plane running through the center of the weapon. The cross section is asymmetrical, the upper side in the figure being convex. The lower flat or nearly so, they must throw this with the right hand. The non-return boomerang has a skew in the opposite direction, but is otherwise similar.

Making boomerangs of the returning type with arms at angles of 70 to 120 degrees is possible; although very few are with an angle of less than 90 degrees. Those made at angles of 110 to 120 degrees are the most common and the easiest to use. Sometimes both arms are of the same length, and some has one arm is an inch or two longer than the other one is.

One side, or the bottom, remains flat while the topside is rounded off to a convex shape. The arms are bent slightly so that the ends are raised above the plane of the boomerang as it lies on its flat side. Each arm has a skew that is the extreme end of each arm is twisted two or three degrees from a plane running through the center. This skew is an all-important factor and no curved boomerang will work without it when thrown from the vertical position.

They may make boomerangs in lengths varying from eighteen inches from tip to tip up to three feet or longer. They recommend that an eighteen-inch or two-foot length be used.

Although the proportions vary somewhat from boomerang to boomerang, it is safe to say that the length of the wing or arm is six times its width at the widest point.

That the width of the wing is six times its thickness at the thickest point. You will find that most

THE CONSTRUCTION OF CROSS BOWS & OTHER WEAPONS

primitive Australian boomerangs will not vary far from these proportions.

BOOMERANG'S FLIGHT

The flight of the boomerang depends mainly on its skew. In throwing they hold the return boomerang vertically, the concave side forward, and thrown in a plane parallel to the surface of the ground, and as much rotation as possible being imparted to it. It travels straight for 150 ft. or more, with nearly vertical rotation, and then it inclines to the left, lying over on the flat side and rising in the air. After describing a circle of 150 ft. or so, it returns to the thrower.

Throws of 300 feet or more, before the leftward curve begins, can be accomplished by expert throwers, the weapon rising as much as 150 ft. in the air and circling five times before returning.

NON-RETURN TYPE

Throwing it at an angle may also make the non-return type return in a nearly straight line of 45°, they throw it like the return type, and will travel a great distance before its flight is ended.

The war boomerang in an expert's hand is a deadly weapon, and the lighter hunting boomerang is effective. The return boomerang is chiefly used as a plaything or for killing birds, and is often as dangerous to the thrower as to the object at which it is aimed.

PATTERNS

The first step is to map out a pattern. This is not at all difficult. Make your pattern just like the detailed drawing of the boomerang shown. First, make a pattern from a piece of paper twenty-one inches long by twelve inches wide. Drawn as indicated, the arms should be sixteen inches long, two-and-one-half inches wide near the angle, and one and one half inches wide at the ends. Cut out the pattern, and draw two lines across it near the bend.

Place the pattern on a piece of Hickory, hard maple, or ash, a five-sixteenths inch thick, and trace each arm of the boomerang. Cut out each arm with a keyhole saw. They must now cut the curved section of each arm (between the lines on the pattern) into a half-lap joint.

Notice in this drawing that the length of this boomerang is 17 inches from one end to the other. In addition, measuring from the rounded front of the boomerang to an imaginary line drawn between the two ends, the total width of the boomerang is 7-9/16 inches.

The actual width of the boomerang itself is 1 3/4 inches wide at the middle, but the width is always less at the ends. The ends are 1 1/2 inch wide as 1/4 inch has been cut away from the boomerang at these points. Both have rounded ends and are raised 1/4 to 3/8 inch higher than the middle of the boomerang. At the center the boomerang is 3/8 to 1/2 inch thick and at the ends it is 3 inch thick.

THE CONSTRUCTION OF CROSS BOWS & OTHER WEAPONS

The bottom bevel mean that they slant the bottom side of the boomerang a little (about 1/16 inch) from the middle to the outer edge. You can see this better in the drawings. They cut the bevel at an angle in the bottom of the boomerang for approximately five in.

They raise both ends of the boomerang higher than the middle. To find the points where the boomerang is to be raised, first, draw one line directly through the middle of the stick. Then mark two more lines at 45° angles from this line. These 45° lines mark the place where the boomerang arms start their upward slant.

THE CONSTRUCTION OF CROSS BOWS & OTHER WEAPONS

HOW TO MAKE THE BOOMERANG

Use Oak, maple, or any other tough wood to make your boomerang. Laminated construction that is several thin pieces glued together to provide the required thickness is best because there is less chance the boomerang will warp, and it will also be stronger.

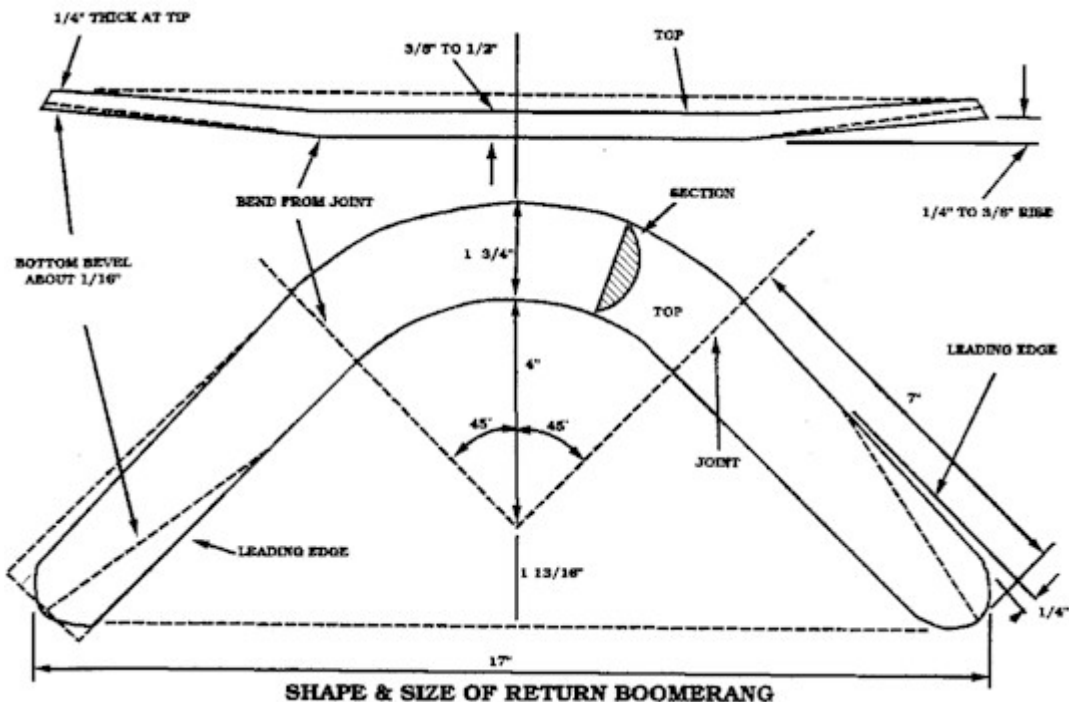

You can also use a solid piece of wood 7/8-inch thick, if you do not have the use of power tools.

Using a band saw or a hand coping saw cut your piece of wood, to the correct size and shapes to represent one half the complete boomerang. Even the solid boomerang will be made up of two or three pieces of wood. Cut this piece length wise through the middle so that you have two pieces the same. This may be a little tricky without a band saw but if you can fasten the strip of wood in the vise and saw it very carefully.

LAMINATED BOOMERANG

You have the choice of making either a solid or a laminated type of boomerang. I will describe the laminated construction first and then the solid. Look at the drawings on Laminated construction. In this drawing, you should glue the butt joint together first. Taper means that the wood is slowly narrowed down. In this drawing taper 3 inch to zero-inch means that, the wood is narrowed down to 3 inch thick from the point where the taper begins.

THE CONSTRUCTION OF CROSS BOWS & OTHER WEAPONS

Two of the strips of wood in this laminated construction are c inch thick and the middle piece is 3 inch thick. They make up the middle section of three strips of wood all are butt jointed together.

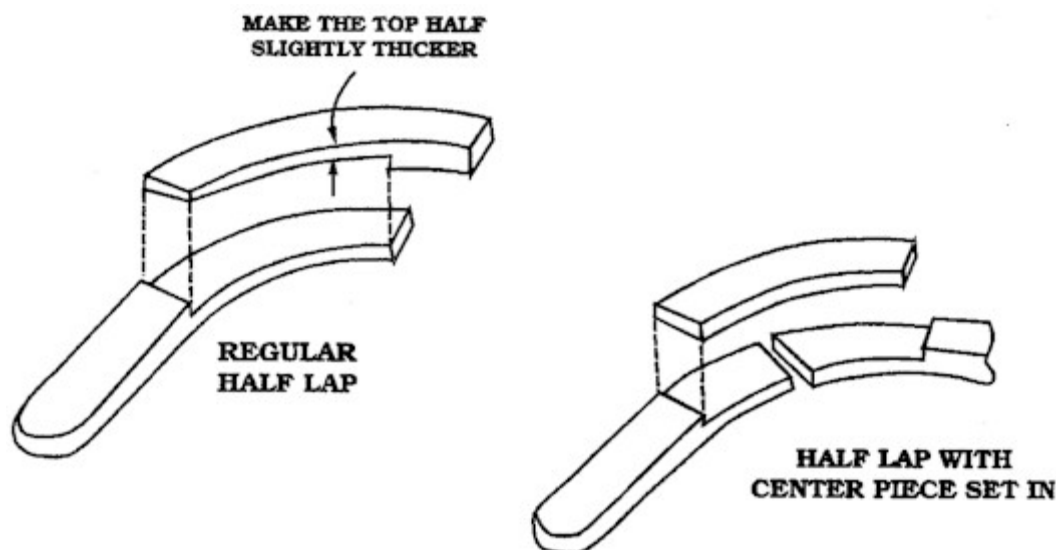

LAMINATING THE SOLID BOOMERANG

Next, glue all three pieces together to form the completed boomerang. Then, place the boomerang on a board. Before the boomerang is ready to be placed in position, you should trace the paper pattern onto this board. You must cut two wedges 7-inch long, with a taper of from d to zero-inch. Place these wedges in position on the tracing. Be sure that they line up the outside edge of these wedges with the outside edge of your drawing.

When done, clamp the boomerang down and allow it to dry.

SOLID BOOMERANG

In making the solid boomerang, we left off at the point where one half of the boomerang was cut lengthwise down the middle so that you would have two pieces exactly alike. It is possible; however, to make an Australian-type boomerang out of two pieces of wood join at the bend. We will describe this method. If one is fortunate enough to secure a curved piece of wood, the wood can be worked and given the skew in the same way that they describe for the one made of two pieces.

Next, cut what they call a half-lap joint in each piece. They cut a small section out near one end of each of the two pieces of wood you now have. You can cut either a regular half lap or a half lap with a centerpiece set in as shown. The half lap with the centerpiece is much stronger and better to use.

If you have a circular saw, cut the half lap with a dado head or a straight molding cutter. If a

THE CONSTRUCTION OF CROSS BOWS & OTHER WEAPONS

saw is not handy cut the half lap with a coping saw. Make the top half of the lap joint a little bit thicker than the bottom.

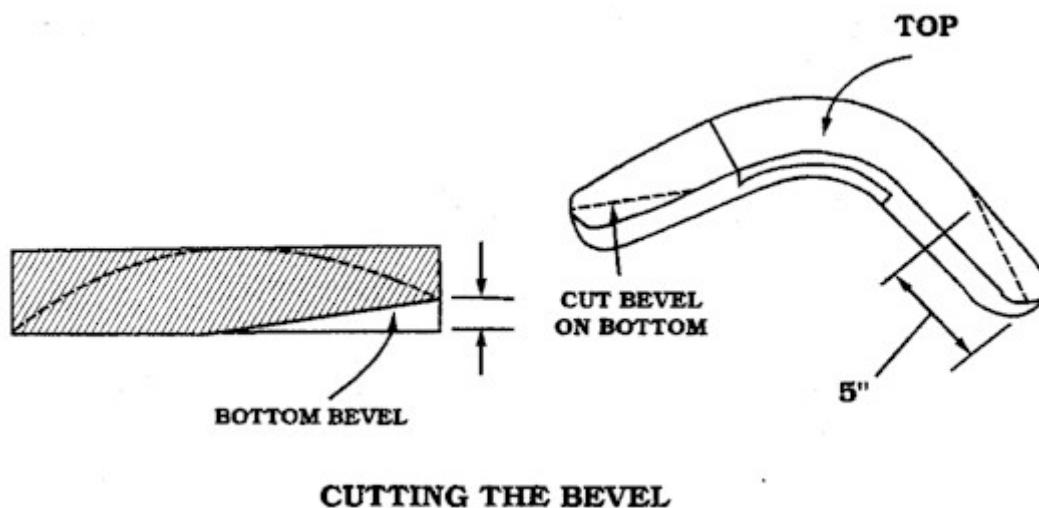

Glue the half-lap joint together and clamp the boomerang tightly to a bench or table. Place two small blocks, 3 to 4 inch thick under the ends of the boomerang. When completely dry, release the clamps and sand or plane the bottom bevel. Normally a 1/16-inch bevel will probably be enough, but you can increase it later if necessary.

SHAPING THE BOOMERANG

Plane the top of the boomerang from joint to tip to get a smooth surface. Be careful not to plane away too much wood. The ends of the boomerang must be 3 inch thick and the middle 2 to 2 1/2 inch thick. Clamp the boomerang down again and, with a wood rasp, round the top surface. Now with drawknife, wood rasp, and jackknife, bevel off the edges on the topside of the boomerang and round off to a convex shape, as indicated in the diagram of the cross section. The stick will remain at its full width at the center, but is pulled down to a feather line at the edges.

SKEW

Giving each end of the boomerang a slight skew is now necessary. Referring to the drawing, which represents the convex side of the boomerang, the end must be so skewed that A is above the plane running through the center and B is below it. Similarly, the other end must be so skewed that E is above the plane and D below it.

To accomplish this skew, heat the end of the boomerang over a gas burner for a distance of about four inches. When hot, grip the end with a pair of heavy pliers held in one hand, and grip the arm four inches from the end with another pair of pliers held in the other hand. Bend the arm two or three degrees in the desired direction and hold for a moment or so. Another way is to hold the arm of the boomerang over a flame so that the flame hits it at a point two thirds of the distance from the end to the curve. When the wood is hot, place the heated spot

THE CONSTRUCTION OF CROSS BOWS & OTHER WEAPONS

against the edge of a table and press hard, thereby bending the arm up slightly. The bend will remain permanently, and then bend the other arm in the same way.

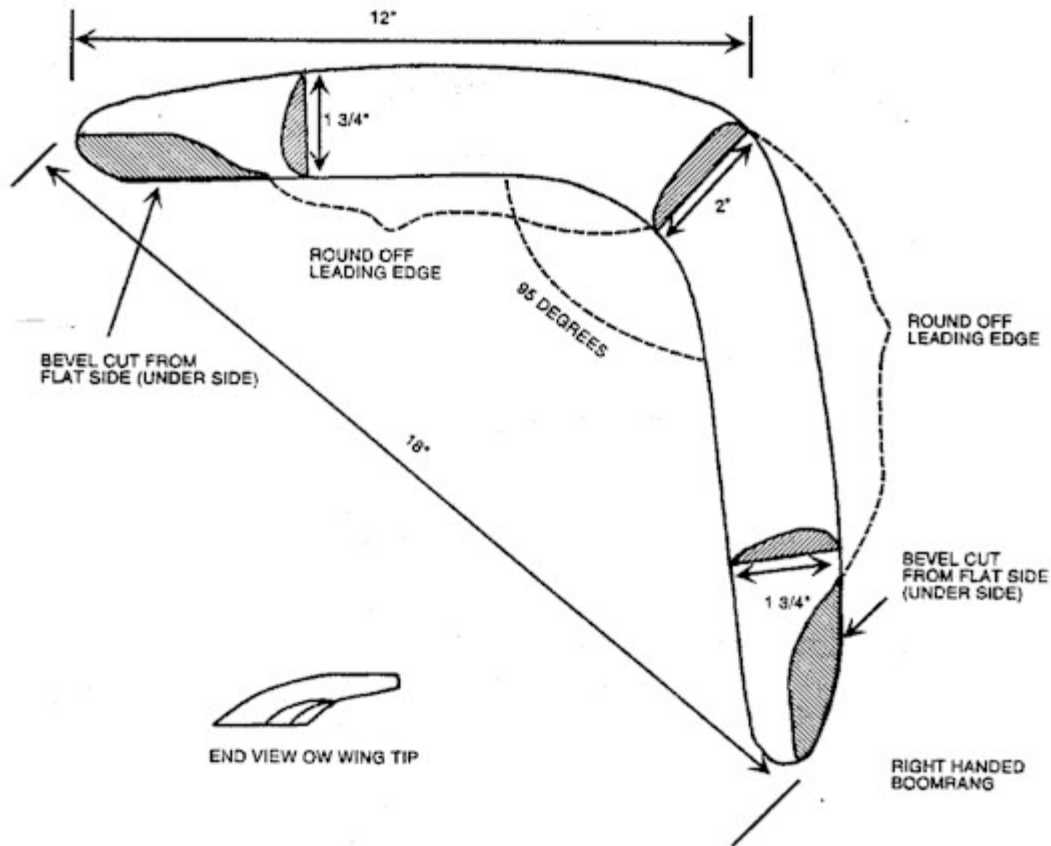

RIGHT HANDED RETURN BOOMRANG

The result now has all of the appearances of a boomerang yet it lacks the essential features that cause it to return. The two secrets here are a bend in each arm, and a skew near each end. Both the bend and the skew are so slight that the average person does not detect them in looking at the boomerang.

Do not leave any blunt edges and try to get a smooth curve with sharp edges. The bottom is flat except at the tips where it is beveled. If you throw left-handed, bevel the corners opposite those showed.

The last step is to apply a coat of varnish or a bright color paint if you are thinking about throwing your boomerang near deep grass where finding it might be hard.

THE CONSTRUCTION OF CROSS BOWS & OTHER WEAPONS

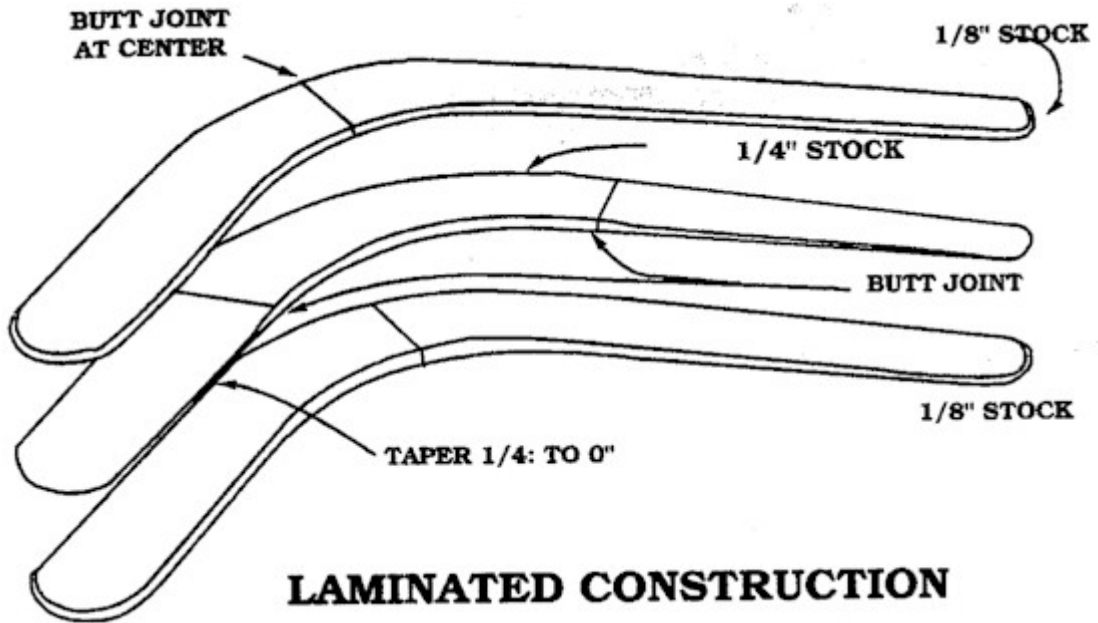

THE CONSTRUCTION OF CROSS BOWS & OTHER WEAPONS

THE NON-RETURN TYPE

The non-return type of boomerang employed by the Australian bushmen for hunting and warfare will travel for great distances with great accuracy. As made by the bushmen, these boomerangs vary from six inches in length to four feet. The big boomerang from Australia measures exactly four feet in length, weighs three, and one-fourth pounds. It is two and one fourth inches at the middle section, this width remaining constant through the greater length of the boomerang. The tapering starts near the ends and come down to one-and-three-fourths inches near each tip.

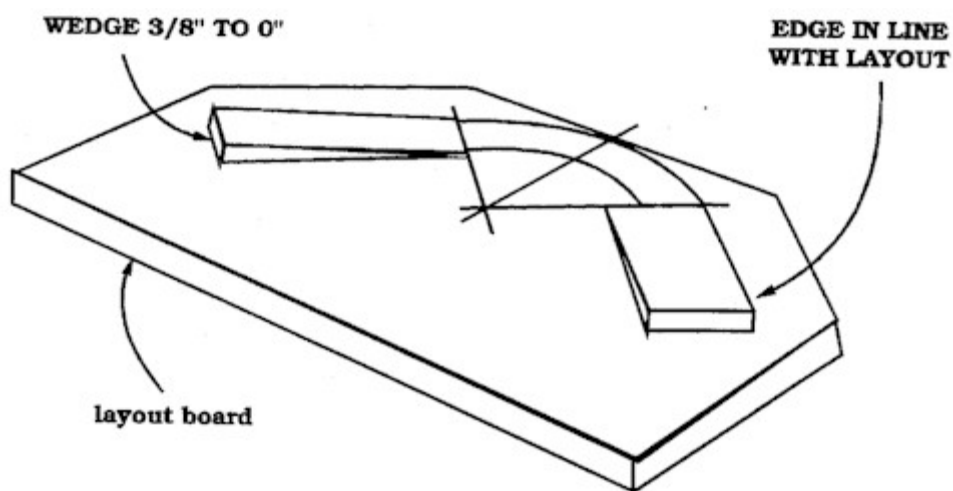

LAYOUT BOARD FOR LAMINATING BOOMERANG

Most boomerangs of this type are sickle shaped and do not have the sharp angle that is characteristic of the return type. Non-return boomerangs are made by the same method described for the return type with one important exception: the skew at the end of each arm is in the reverse direction from that found in the return type. That is, B is higher than the plane of the boomerang and A is lower; similarly, D is above the plane and E below it.

When thrown in a position vertical to the ground this type of boomerang will travel for a long way without swerving to the right or left. They can make it to come back, however, if they throw it from a position parallel to the ground. It then rises at a steady angle to a great height and then glides and volplanes down to the thrower.

THE CONSTRUCTION OF CROSS BOWS & OTHER WEAPONS

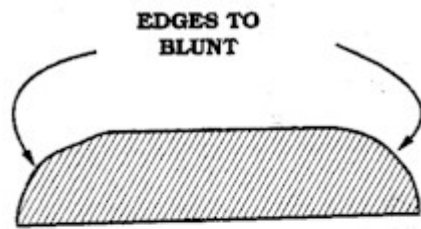

INCORRECT SHAPE

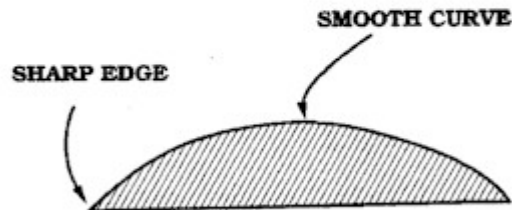

CORRECT SHAPE

CORRECT SHAPE OF LIMBS

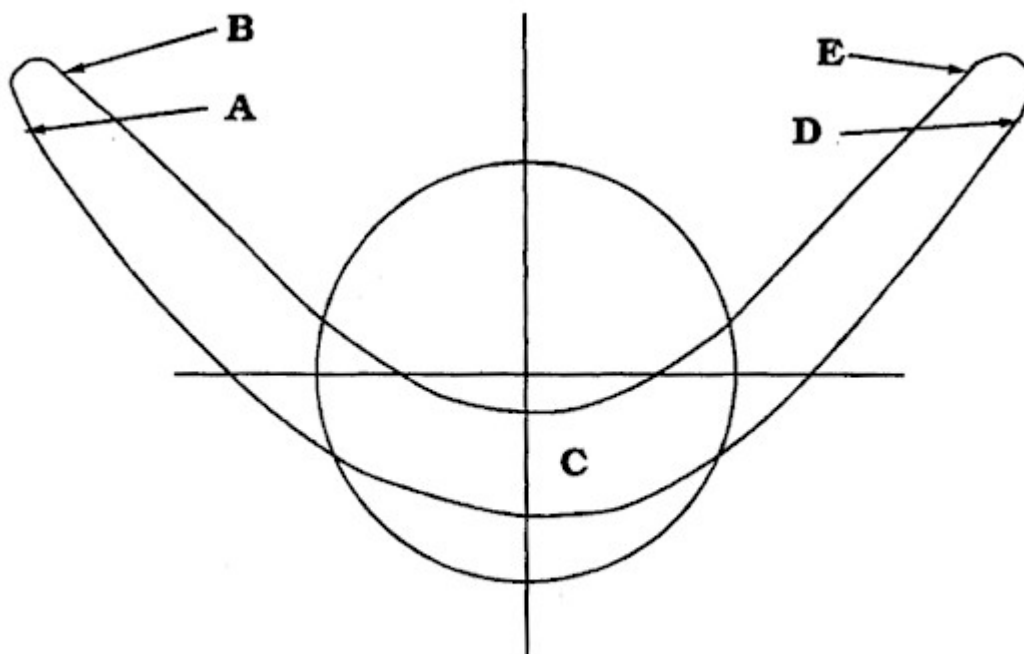

SHAPE OF RETURN BOOMERANG

THE CONSTRUCTION OF CROSS BOWS & OTHER WEAPONS

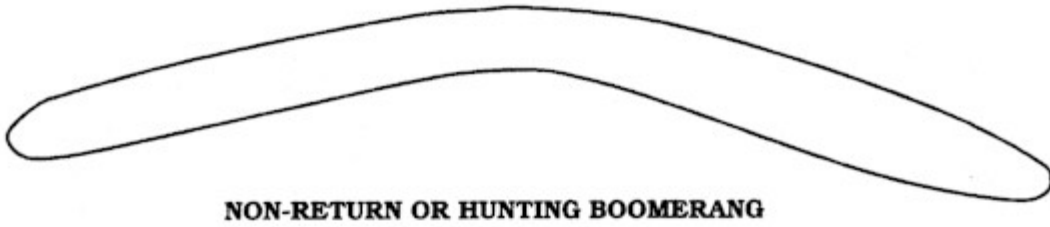
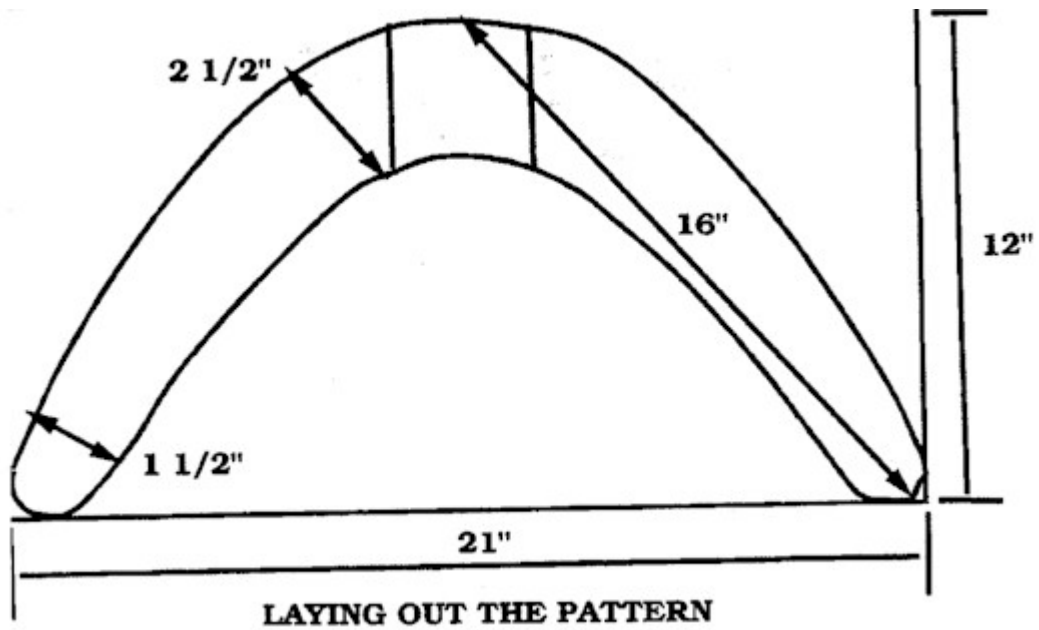

THE CONSTRUCTION OF CROSS BOWS & OTHER WEAPONS

THROWING THE BOOMERANG

Throwing the boomerang is very easy. They must always throw the boomerang against the wind. It is only against the wind that the boomerang automatically returns to the thrower.

Now throw the boomerang and if it does not return properly, increase the skew a little, experiment by increasing and decreasing the skew until you get the results on want.

Making a boomerang of this type return or even swing to the left with an indication of returning is impossible unless they give the arms a skew in the direction shown above.

Facing the wind, you hold the boomerang in your right hand with the rounded side inward, that is, the round side should be the left side of the boomerang when held in throwing position by a right-handed thrower. Holding firmly to one end, bring the stick over your head.

Now, bring the arm forward in a straight overhand swing and release the stick with a short upward jerk of the hand, somewhat like that used in cracking a whip. This is important to do for without this sharp jerk; the boomerang gets off to a slow spinning start and will not revolve fast enough to make the return journey. With the snap correctly done, the boomerang will zoom forward.

In a good flight, the boomerang will swoop straightforward rising swiftly upward for a distance ranging from 100 to 350 ft. After it travels 100 to 350 ft., it changes to an almost horizontal level, and then, swerving to the left, it soars aloft like a bird and then returns to land at the thrower's feet.

Although the throw is generally as described, they can make the boomerang to do several graceful arcs. With slight variations of the snap, they can make the boomerang to shoot inward with terrific swiftness, curve outward in a lazy arc, or shoot upward in spinning flight. You will soon gain sufficient skill to score a hit fully half the time at a distance of from 40 to 60 yards.

THE CONSTRUCTION OF CROSS BOWS & OTHER WEAPONS

THROWING THE CURVED AUSTRALIAN BOOMERANG

The curved Australian Boomerangs of the return type are thrown just as described above except that they must be hurled with great force as compared to the other types, and are given the spin or revolving motion in a different way. Just as the boomerang is released, the hand is given a sharp upward jerk. This sharp Jerk is important because without it the boomerang will spin lazily at the start and will not have enough revolving motion to make the return journey. Most Australian Boomerangs will perform correctly if thrown from the straight up-and-down position illustrated in B, Figure 42. It is seldom necessary to throw from the positions shown in A and C.

The average boomerang of the return type will go forward thirty to fifty yards before swinging to the left, then rise high in the air, and volplane back.

The non-return type is thrown in just the same way if the object is to hurl it accurately at a target some distance away. It is possible to throw these non-return boomerangs so that they 'll come back, but this method is described in the following section on the horizontal throw.

THE CONSTRUCTION OF CROSS BOWS & OTHER WEAPONS

MAKING CROSS STICK BOOMERANGS

The Cross stick Boomerangs are the pinnacle of boomerang perfection. They are the most accurate of all the boomerangs and consequently are the most satisfying. So accurate is a good Cross stick Boomerang that an expert can stand upon a stage, even in a small theater or hall, and throw it out over the heads of the audience without fear that it will hit a wall or dive surreptitiously onto the head of an unsuspecting spectator. So accurate is it in fact that one can often "call his shots," that is, throw the boomerang and immediately hold out his hand indicating the exact spot to which it will return. The symmetrical, balanced construction of these boomerangs causes them to cut a more perfect circle in the air and return with more precision than any other type. A good Cross stick or Pin wheel can be depended upon to act in precisely the same way each time it is thrown.

The Cross stick Boomerangs are usually made of light, soft wood, and this, together with their accuracy and dependability, recommends them as relatively harmless, delightful playthings. They can be used with safety in any gymnasium or large hall, following the directions given in Chapter VII, "How to Throw

Moreover, the Cross-sticks are the easiest type of boomerang to make. The process is so simple that any one, after reading the instructions in this chapter, should be able to fashion one in a few minutes that will work with the utmost perfection if properly thrown. Certainly the beginner at the sport should be introduced to the simple Cross stick before he makes the acquaintance of the other styles. In fact, practically all of the essentials in the art of the come back missile are presented in this chapter on the Cross-sticks this is the basic type. The unique models of boomerangs described later are unusually fascinating novelties and very much worthwhile, but they are merely colorful variations based on the principles of the Cross stick.

There are two main types of Cross sticks: The first is the Four wing Cross stick made of two pieces of wood set at right angles to each other as in Figure 4, page 19. This is the simplest form of boomerang. The second is the Pinwheel, which is a six-wing boomerang, made of three pieces of wood fastened together in the middle. This is the Cross stick at its best the steadiest and most dependable of the boomerangs. The present chapter deals with the simple Four wings Cross stick and its variation, the two wing type. The Pinwheels are described in the next chapter.

The methods of throwing boomerangs are described in Chapter VIII. Since all boomerangs are manipulated according to the same principles, these instructions apply to the Cross-sticks in this chapter and to all other types.

MATERIALS REQUIRED

Few indeed are the materials required for making boomerangs some wood of the suitable type and a few simple tools.

THE CONSTRUCTION OF CROSS BOWS & OTHER WEAPONS

WOOD FOR BOOMERANGS

Of utmost importance is the wood that goes into a boomerang, yet happily, the proper woods are never scarce in any community. With one exception all types of boomerangs call for soft, lightwood, the exception being the curved boomerangs of the Australian type, which are made of heavy, hard wood as described in Chapter VI. Wood is the only material from which boomerangs can be made successfully, all efforts to construct them from metal having proved unsatisfactory to date.

The ideal woods are basswood, tulip (whitewood), and select cuts of Number I white pine. Spruce and cedar are usable but less satisfactory. Basswood is the choice above all others; it is usually straight grained, does not split and splinter as much as most soft woods, is strong for its weight, and very easy to whittle. Furthermore, as compared to many woods, it has the excellent quality of consistency in weight and texture.

There is no better wood than the right piece of white pine, but many pine boards contain so much pitch in the grain as to make them hard to whittle evenly with a jackknife. Moreover, the sticks cut from a board often vary too much in weight. Some lumberyards sell small boards prepared for cabinetwork, which they label as "select cuts of Number I pine." These strips usually come in thickness of one eighth inch and one fourth inch, these being the exact measurements needed for our purpose. The finest boomerang wood I have ever used has been found by sorting over such stumps and selecting lightweight pieces free from pitch. Not all pine comes up to this standard.

Often as perfect a piece of wood as one could desire can be picked up from an old packing box. If it is soft, strong, and straight grained, it should make a good boomerang. However, much better results will be obtained by securing from a lumberyard some strips of basswood, whitewood, or Number I pine in the proper thickness. The boomerangs in this chapter call for two thickness one eighth inch and one fourth inch. Care should be taken to select clear, straight-grained pieces, free from knots.

Much of the joy of boomerang making will be lost if the wood is so coarse and stubborn that it does not whittle easily and smoothly.

Balsa wood immediately comes to one's mind in connection with boomerangs because of its use in making light weight ones. However, this wood is so light as to be entirely unsatisfactory and has no place whatever in boomerang making. A boomerang made of it is so very light that it cannot be thrown with enough force to carry it.

TOOLS REQUIRED

Boomerang making is essentially jackknifed whittling. The only absolutely indispensable implement is a good, sharp, and pocketknife.

THE CONSTRUCTION OF CROSS BOWS & OTHER WEAPONS

In making boomerangs of ordinary size a three-fourths inch gouge and a candle will be helpful, and in undertaking very large boomerangs, a wood rasp and a brace and bit will find use.

In assembling the boomerangs an assortment of bolts and nuts will be needed, the sizes being stated in connection with the description of each boomerang.

A tube of liquid solder or quick drying cement will be of assistance in repairing the broken wings of boomerangs and the sticks that split while being whittled.

If one is interested in finished and polished workmanship, a drawknife, plane, and some sandpaper will be useful. Such a quality of workmanship is always commendable in any line of effort, but the typical boomerang is left in a rather rough stage of finish being a primitive type of instrument, it seems to possess more color and atmosphere if rather crude and irregular in appearance. Such a boomerang performs just as accurately as does a finely polished one. This is a matter of taste, however, and one can finish them to suit his fancy.

The matter of paint is discussed later in the chapter under the heading, "Decorating Boomerangs."

THE CONSTRUCTION OF CROSS BOWS & OTHER WEAPONS

FOUR WING BOOMERANGS

The four wing boomerangs are made of two sticks crossed at right angles and bolted in the center, as illustrated in Figure I. They are frequently referred to simply as Cross-sticks.

When thrown, a lightweight boomerang of this type will cut almost a perfect circle in the air. They move more swiftly than do the Pin wheel (six wing) Boomerangs that will be described in the next chapter, but are no less accurate. Large and heavy Cross sticks frequently travel in a straight line for a long-distance, then turn around rather abruptly to the left and return on almost a direct course. However, the characteristic course of flight of this type of boomerang is a circular one.

THE CONSTRUCTION OF CROSS BOWS & OTHER WEAPONS

YOUR FIRST BOOMERANG

One's first attempt at boomerang making should be confined to small sticks. In making the little boomerang here described, we will become familiar with all of the essential techniques in boomerang construction, thus making it possible for us to attempt the larger ones with ease and assured success.

Secure two of the ruler like sticks used by gasoline stations to measure the amount of gasoline in automobile tanks. These are usually of the right dimensions and made of the right kind of soft wood. Failing here, secure two strips of basswood or other soft wood eighteen inches long, one and one fourth inches wide, and one eighth inch thick.

Place each stick on the edge of your knife blade and balance it to determine the center of gravity, and mark this point. The center of gravity is used as the center of the stick, rather than the center of measurement. Mark out a two-inch section in the center of each stick as shown in C, Figure I. With a jackknife, trim off the edges on one side of the stick beyond these lines so that it is roughly convex, as indicated in C, Figure I, and shown in the diagram of the cross section, F, in Figure I. Note that the bottom or backside remains flat, while the top side is roughly rounded off. The edges should be drawn down to a feather line, but the stick remains full width at the center.

All this is done with a jackknife and consequently the sticks are somewhat irregularly convex, but so far as efficiency of the boomerang is concerned, this irregularity makes no difference provided the edges are rather uniformly thin. In fact, it is not absolutely essential that the top of the stick be entirely rounded off to a convex shape it is usually sufficient merely to bevel the edges down to a thin line.

Now each end of the sticks must be given a slight bend upward, that is, toward the beveled or convex side. This is a task for but a moment or two: hold the stick over a lighted candle so that the flame strikes it six inches from the end, as illustrated in Figure 2. When heated hold the stick with the fingers as shown in Figure 3, bend upward slightly, and hold in this position for a few seconds the curve will then be permanent. A very slight bend is all that is needed not over a quarter of an inch. Both ends of each stick are bent in the same way; care should be taken in each case to apply the heat at a point the same distance from the end, and to bend each end about the same amount.

In camp the wood may be bent on a small rock heated in the campfire. When the rock is hot withdraw it from the fire, moisten the stick with the tongue at the point where it is to be bent, then place the moistened spot on the rock and bend to the desired angle.

Hold it there for a moment and the curve will be permanently fixed.

To complete the boomerang, place one stick across the other and fasten together, as shown in E, Figure I we thus have a flying missile with four wings. Little boomerangs such as this are best held together by wire. Use soft wire that bends easily and run it straight across the stick

THE CONSTRUCTION OF CROSS BOWS & OTHER WEAPONS

as shown in G, Figure I not diagonally across. When the wire is attached, it may be tightened by grasping it with the pliers and twisting, thus giving it the 2 shapes indicated in G, Figure I.

Another very satisfactory method of holding small boomerangs together is to cement them by putting a drop of solder or quick drying cement at the intersection. This holds the sticks together firmly and permanently, yet adds practically no weight.

Although less acceptable on small boomerangs, the sticks may be bolted together. Use a one eighth inch bolt and wing nut. Wing nuts are always desirable in that they can be tightened without the use of pliers, and tightening is frequently necessary when the boomerang is in use.

THE CONSTRUCTION OF CROSS BOWS & OTHER WEAPONS

MAKING LARGE FOUR WING BOOMERANGS

The making of the little Cross stick Boomerang described in the preceding section will serve merely as an incentive for the fashioning of larger and more colorful ones. Every essential of boomerang construction was involved in making the little boomerang of gasoline sticks; however, and consequently the large Cross-sticks follow the same general pattern and formula.

To make an excellent boomerang of the ideal size for general use, cut two strips of basswood, whitewood, or pine, twenty-four inches long, one and one half inches wide, and one-eighth inch thick. Bevel the edges on the top side throughout the entire length of each stick, bringing them down to a feather line, and round off the top to a roughly convex shape, as described in the preceding section.

The corners at the end of each stick should be trimmed off to the curved shape shown in Figure 4. Note, however, that the end is not cut to a semi circular shape, but rather, more wood is removed from the left corner of the upper wings than from the right corner this is true of each wing when it is placed in the upper position. The reason for this is that the left or cut off side is the point that cuts into the air as the boomerang sails, and likewise it is the point that hits the ground or an obstruction in case the boomerang should fall; the wing is less inclined to split when trimmed off in this way. Do not bevel or thin down the ends of the sticks the wood should be left at full thickness here to insure all possible strength.

Now hold each stick over a candle at a point eight inches from the end, and when heated, bend it slightly toward the convex or beveled side, as described in the preceding section.

Bend each of the four wings in the same way.

Regardless of the size of the boomerang, the point of bending is approximately two thirds of the distance from the end to the center. This is clearly illustrated in Figure 2.

Boomerangs two feet or more in length should be bolted rather than wired. A 1/8 or 3/16 inch bolt, 3/4 inch long, equipped with a wing nut, is proper for all except very large and heavy boomerangs, which latter require a 1/4-inch size. The wing nut should be placed on the top side of the boomerang, as shown in Figure 4.

One of the interesting tricks in boomerang throwing involves the use of a long bolt as illustrated in Figure 5. As the boomerang returns, the performer catches it by the bolt and the boomerang thus continues to spin as he holds it in his hand. So fascinating is this method of catching that it is well to equip all Cross sticks two feet or more in length with these long bolts. Using a bolt four or five inches long, place a nut and washer a half inch from the end, insert the end through the two blades, place a washer on top, and hold with a wing nut. Figure 5 shows the arrangement clearly.

THE CONSTRUCTION OF CROSS BOWS & OTHER WEAPONS

These long bolts should be as light in weight as the size of the boomerang will permit a three sixteenth inch size is large enough for all except extremely heavy boomerangs.

No type of nut is satisfactory for use on boomerangs unless it can be tightened with the fingers, without the use of pliers. Since the nut tends to loosen in throwing and must be frequently tightened, it is a great convenience if it can be adjusted with the fingers. Two types of nuts meet this requirement, the wing nut (Figure 7) and the toggle bolt and nut (Figure 6). The laker is particularly desirable on large boomerangs.

When the two sticks are bolted together as in Figure 5, the boomerang is completed and ready to throw.

If the boomerang dives to the ground, or cuts in at you without turning into a horizontal position and floating in easily and gently, it probably is too heavy and needs to be lightened. This is accomplished by gouging out some of the wood on the back or flat sides of the sticks. Use a three-fourths inch gouge for this. A few chips may be removed as in A, Figure 8, thus lightening the weight slightly, or the entire length of the stick may be gouged out uniformly, making the bottom side concave as shown in B, Figure 8. Most large boomerangs need to be lightened in this way.

The Two Secrets of the Boomerang. It will be noted that there are two processes in preparing sticks for a boomerang: (1) rounding off the top side to a roughly convex shape while the bottom remains flat, and (2), bending each wing slightly toward the convex side. These are the two secrets in boomerang construction. It is the convex or beveled shape of the topside that is the primary factor in causing the boomerang to return. The bend in the wings causes the boomerang to tend to turn over into a horizontal position and thus to float and sail, staying in the air until it has had time to return.

The bend in the wings forms a dihedral angle, which helps the boomerang to glide and volplane. An occasional boomerang will be found that will return satisfactorily without the angle or bend in the wings, but this is not often the case such boomerangs usually tend to dive heavily to the earth before completing the return.

THE CONSTRUCTION OF CROSS BOWS & OTHER WEAPONS

BOLAS

This is a South American Indian weapon of war and the chase, consisting of balls of stone attached to the ends of a rope of twisted or braided hide or hemp. The bolas, or balls, are of two kinds, the simplest, which is used chiefly for catching ostriches, consists of two round stones, covered with leather, and united by a thin, plaited thong, about 8 ft. long.

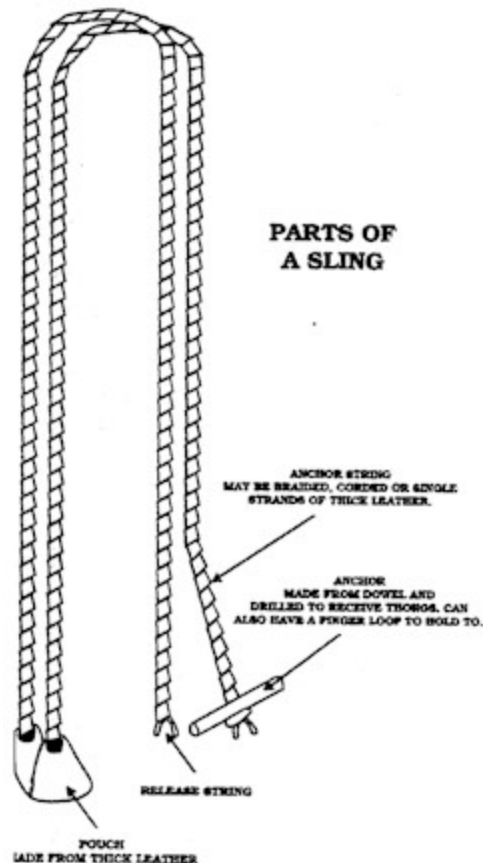

The other kind differs only in having three balls united by thongs to a common center. The Gaucho holds the smallest of the three in his hand, and whirls the other two around his head, then taking aim, sends them like chain shot revolving through the air. When the balls strike any object; they whip around each other, and become firmly wrapped around the object they hit.

SLING

- * a. If using rocks, use rocks that are rounded but have a slightly flattened side.
- * b. Place the rock in the pouch with the flattened side down.
- * c. Secure anchor string and release string as shown in the drawing.

THE CONSTRUCTION OF CROSS BOWS & OTHER WEAPONS

- * d. Adjust the length of release string so that rock is lying parallel to the ground in a pouch when allowed to hang to the ground.
- * e. Maintaining this grip begin swinging the sling around and above the head. The centrifugal force will hold the rock in.
- * f. As the loaded pouch passes in front of the eyes, line up the circular path with your target, as it passes in front of your eyes.
- * g. For longer distances, you should allow your arc to aim more upward.

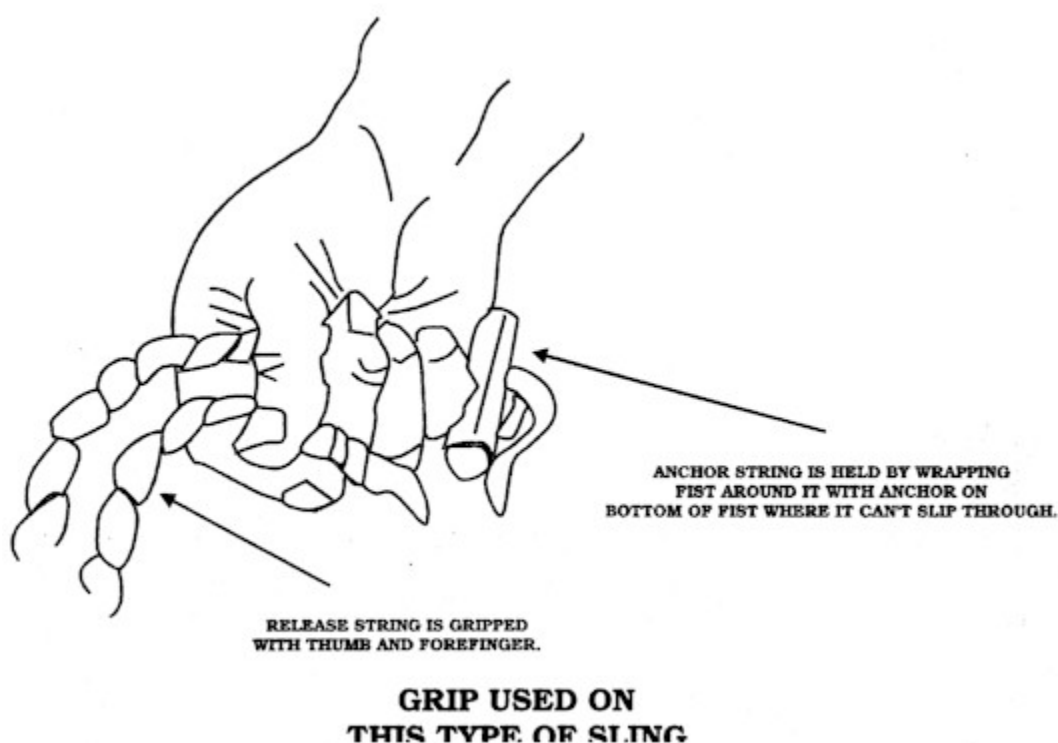

* When aligned with your target, to release, turn the circular trajectory into an overhand throw. This is just as if you were throwing by hand as the sling is an extension of your arm. It adds power to your throw due to the momentum achieved by swinging it about your head.

Release the release string only and it will free the projectile to fly forward to the target at which you are aiming. You must practice to become accurate with this weapon.

The sling is probably the earliest device by which force and range were given to the arm of a thrower of missiles. Sling stones from the stone age are frequent. The type of weapon is of two 3 kinds; the sling proper consists of a small strap or socket of leather or hide to which two cords are attached, the stinger holds the two ends in one hand, whirls the socket and missile rapidly round the head and, loosing one cord sharply, dispatches the missile; the other type is the staff sling, in which the sling itself is attached to a short staff, held in both

THE CONSTRUCTION OF CROSS BOWS & OTHER WEAPONS

hands. This was used for heavier missiles, especially in siege operations during the middle ages. There are many references to slings and to slingers in the Bible, and the left-handed slingers of Benjamin were famous. The Assyrian monuments show the sling of the ordinary type and slingers were used in the ancient Egyptian army, but not before the 8 th. Century BC.

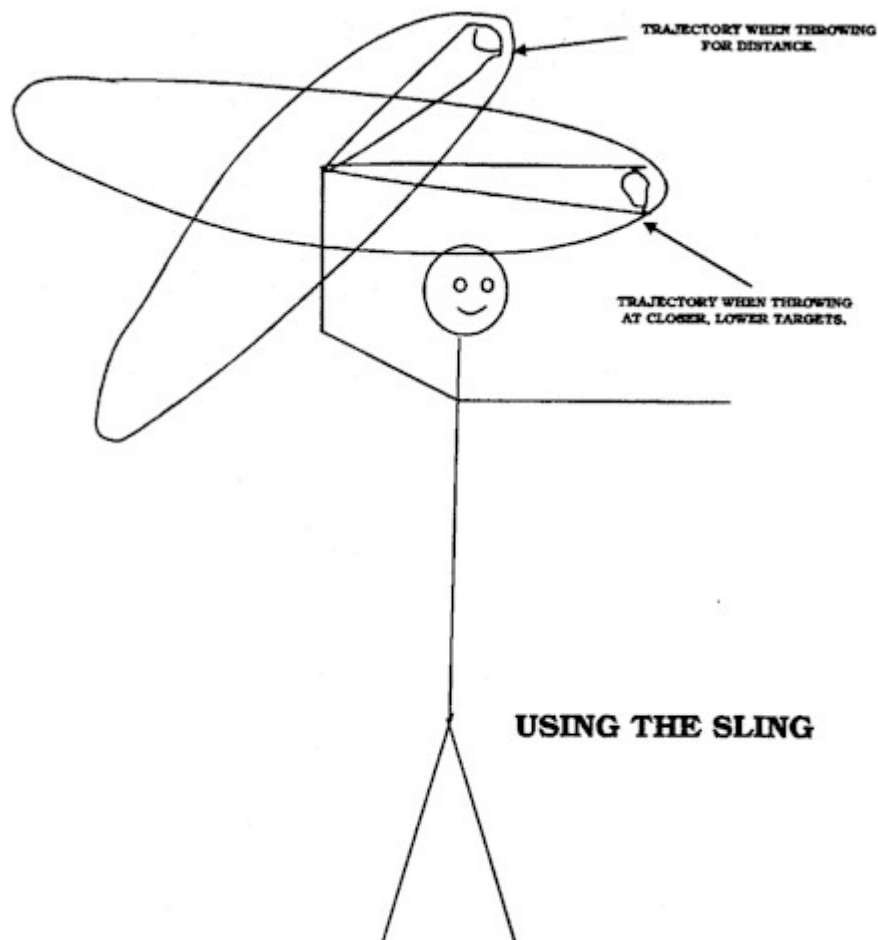

The slingers in the army offered by Gelon to serve against the Persians; it seems to have been a weapon chiefly used by barbarian troops. The Acarnanians, however, were expert slingers, and so also were the Achaeans, who later invented the sling, which discharged a shaft with an iron bolt head from Polybius.

In the Roman army by the time of the Punic wars the slingers were auxiliaries from Greece, Syria and Africa. The Balearic islanders, who were in Hannibal's army, were always famous as slingers. In mediaeval times the sling was much used in the Frankish army, especially in defending trenches, while the staff-sling was used against fortifications in the 14 th. century. Till the 17 th. century, they were used to throw grenades.

THE CONSTRUCTION OF CROSS BOWS & OTHER WEAPONS

ADDRESSES

Associations

The National Archery Association

1750 E. Boulder Street

Colorado Springs, CO 80909

The National Crossbowmen of the USA

Longwood Gardens

KENNETT SQUARE, PA 19348

MAGAZINES

The British Archer

68 The Dale

Widley, Portsmouth

P07 5DE, UK

The National Crossbowmen of the USA

c/o National Archery Association

1750 E. Boulder Street

THE CONSTRUCTION OF CROSS BOWS & OTHER WEAPONS

Colorado Springs, CO 80909

The Journal of the Society of

Archer Antiquaries

71 St. John's Road

Swalecliffe, Whitsatable

Kent, UK

SUPPLIERS

Dave Benedict, Crossbows

Box 343

Chatsworth, CA 91311

Full Adjust Archery Products

915 North Ann Street

Lancaster, PA 17602

Martin Crossbows

Rt. #5 Box 65

Huntsville, AK 72740

THE CONSTRUCTION OF CROSS BOWS & OTHER WEAPONS