

# SIDAC / IGBT SPARK GAP "SISG"

Terry Fritz  
July 27, 2006  
Rev 1.9 minor updates

## INTRODUCTION

A new "electronic" spark gap using reliable, simple, and totally self contained sections is discussed. These sections can be combined, in series, to allow high voltage switching at high current with very low loss. By using SIDACs for voltage controlled triggering and IGBTs as a current pass element, each section can fire at a preset voltage and stay on for a predetermined length of time. The effective resistance of each section is extremely low compared to a conventional spark gap - drastically reducing power loss.

## BACKGROUND

On March 2, 2001, Antonio Carlos M. de Queiroz made a post to the Pupman Tesla coil mailing list describing a DC switching topology that formed the basis for the OLTC, DRSSTC, and now the SISG:

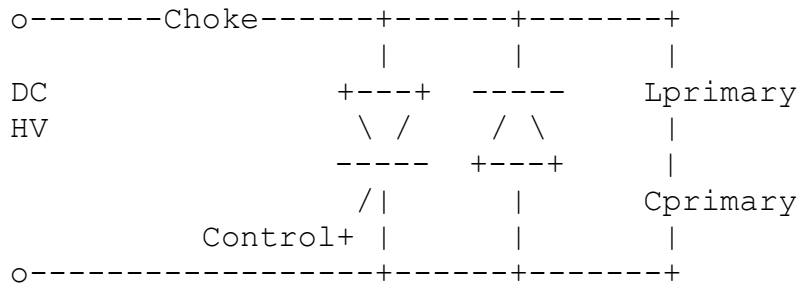

The SCR would hold the primary voltage for some time and, when triggered, would be automatically turned off after each half cycle, while the diode conducts.

There are many high power IGBTs that already have the antiparallel diode built into them and they can take hundreds or thousands of amps for a short duration. Thus, a fundamental building block for high power disruptive Tesla coils was introduced. The OLTC used one such block of very high current but low voltage. The DRSSTC uses four blocks in an H-bridge configuration. However, these systems have been limited to 300-600 volts due to the difficulty in stacking many such sections together. They have also required considerable control electronics which makes such systems far different than conventional spark gap type Tesla coils. However, the performance of the DRSSTC is outstanding!

# THEORY OF OPERATION

The SIDAC/IGBT Spark Gap or SISG is in many ways a “drop in” replacement for conventional spark gaps. The SISG's basic operation is identical to a conventional spark gap. However, the high voltage must now be rectified to DC so that the polarized IGBT is able to control the current. A conventional Tesla coil system and one using the SISG is shown in Figure 1.

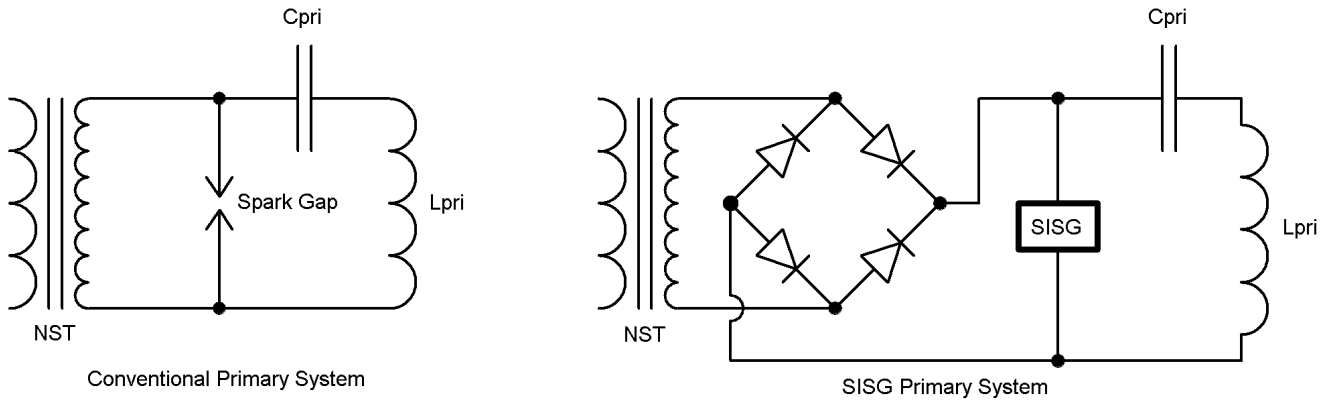

Figure 1. Conventional and SISG coil system comparison.

The bridge rectifier can simply be a series array of many small very inexpensive 1000V 1A rectifiers such as the 1N4007 in series to withstand at least twice the firing voltage.

The actual circuit schematic and parts list is shown in Figure 2.

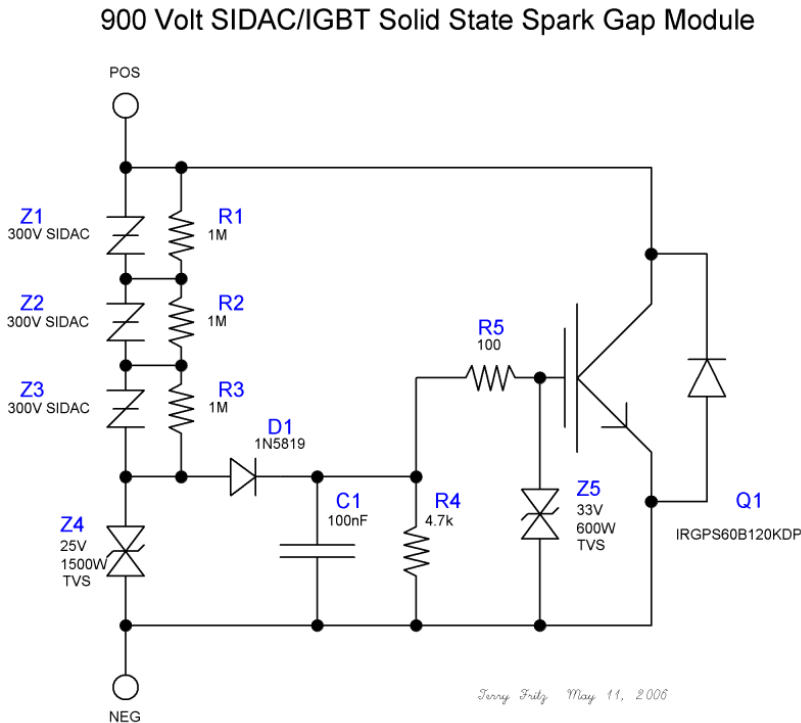

Figure2. Individual section schematic diagram

## Parts List

REF	QTY	DigiKey#	Description	Cost (10)	Total
C1	1	495-1294-ND	100nF 250V Poly Capacitor	0.37	0.37
D1	1	1N5819DICT-ND	1N5819 Diode	0.30	0.30
Q1	1	IRGPS60B120KDP	1200V IGBT with Diode	14.95**	14.95**
R1-R3	3	1.0MQBK-ND	1M Ohm 1/4W Resistor	0.02	0.06
R4*	1	4.7KQBK-ND	4.7K Ohm 1/4W Resistor (5k pot!)	0.02	0.02
R5*	1	100QBK-ND	100 Ohm 1/4W Resistor (51 Ohms)	0.02	0.02
Z1-Z3	3	K3000F1-ND	300V TO-202 SIDAC	0.86	2.58
Z4	1	1.5KE24CADICT-ND	24V 1500W Bi-TVS	0.60	0.60
Z5	1	P6KE33CADICT-ND	33V 600W Bi-TVS	0.45	0.45
Cost per 900V SISG section.					19.35

Note that the heat sink, thermal glue, PC board, hardware... will add to the cost.

\*The values of R4, and possibly R5, are adjusted to a specific system. R4 should probably be a small 5k pot! R5 should probably be 51.

\*\*Check with <http://irf.com> for the best priced supplier. The leaded version (IRGPS60B120KD) is commonly available and far cheaper!!

There are, of course, components other than the ones specified here that can be used. The basic circuit is simple and not critical. The IGBT needs too have a very high pulse current capability with low CE resistance. And the capacitor should be a high current pulse type. The path lengths from the emitter through the gate charging circuit should be kept short to minimize inductance. At say 800 amps, only 10nH of emitter inductance can add 12 volts to the gate voltage! Z5 controls that in any case.

The actual operation of the circuit is as follows:

As the voltage across the system increases, there is no current flow until the SIDACs fire at about 900V. The resistors R1-R3 and R4 equalize the voltage across the series arrays during the primary cap charging cycle as shown in Figure 3.

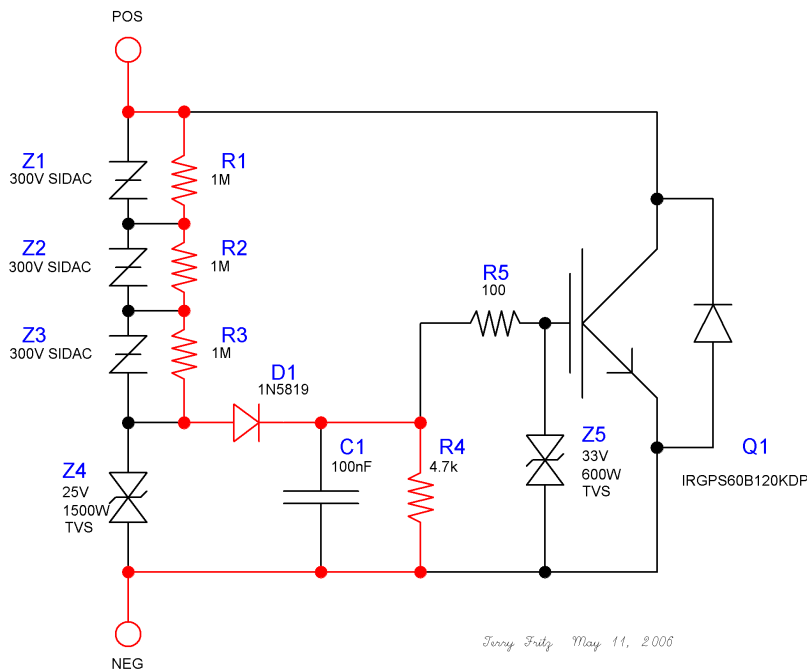

Figure 3. Pre-firing state.

Note that at "just under" 900V there is 1.4 volts across the IGBT gate.

Once the SIDACs fire, the initial primary current flows in the path shown in red in Figure 4. If we assume a 250kHz primary system with a peak current of 500 amps (a fairly stressful case), the current will increase at a rate of 785A/uS.

$$V = 1/C \int i(t) dt \implies 25 = 1 / 100E-9 \times 785E6 T^2 / 2 \quad T == 64nS$$

So the capacitor reaches a 25V charge in roughly 64nS.

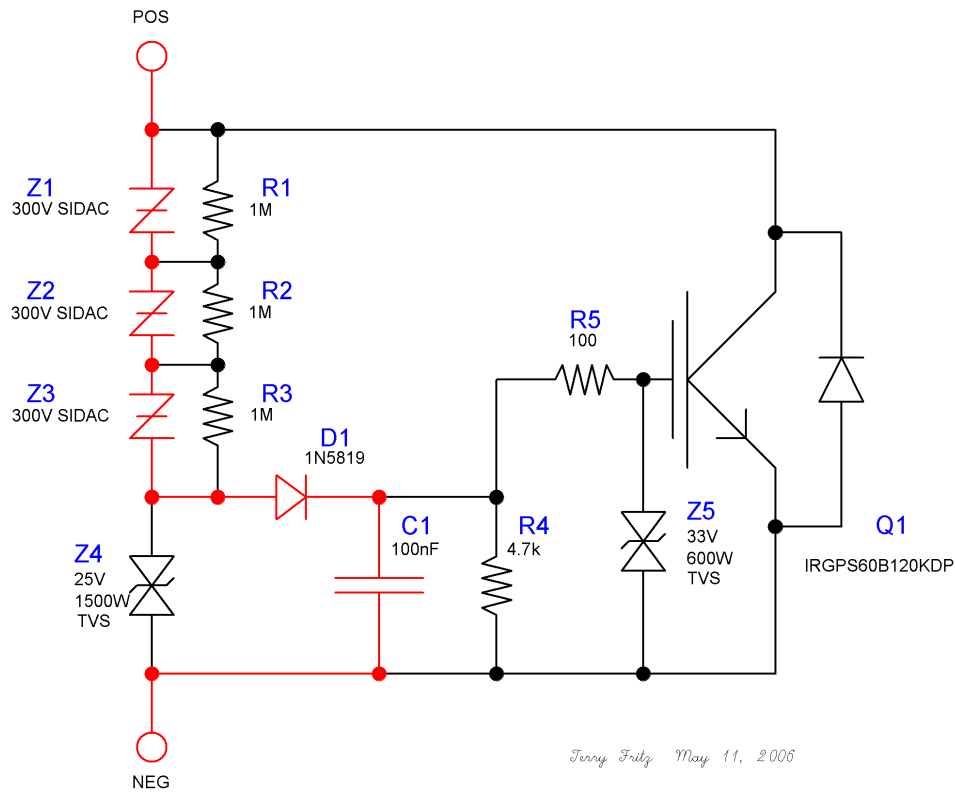

Figure 4. SIDAC firing state.

When the capacitor reaches 25V, the transorb takes over the main current load as shown in red in Figure 5. This string is rated at roughly 100 amps which "hopefully" gives time to turn on the IGBT to take over the full circuit current load (200nS).

The IGBT shown has an input capacitance of 4.3nF. and it begins charging with the capacitor but slower due to the 100 ohm resistor. The resistor slows the IGBT turn on so the capacitor can charge to full voltage. If we assume the IGBT begins to turn on hard (100 amps) at 9 volts, we can find the time it takes for the IGBT to take over the load current.

$$V_g = V_o (1 - e^{-(T/RC)}) \implies 9 = 25 (1 - e^{-(T / (100 \times 4.3E-9))}) \quad T = 192nS$$

We add the 64nS from before for a total time of 256nS (just in time ;-))

The resistor value can be changed as needed. Lately, it looks like 51 ohms might be a better value for  $T_{on} = 162nS$ .

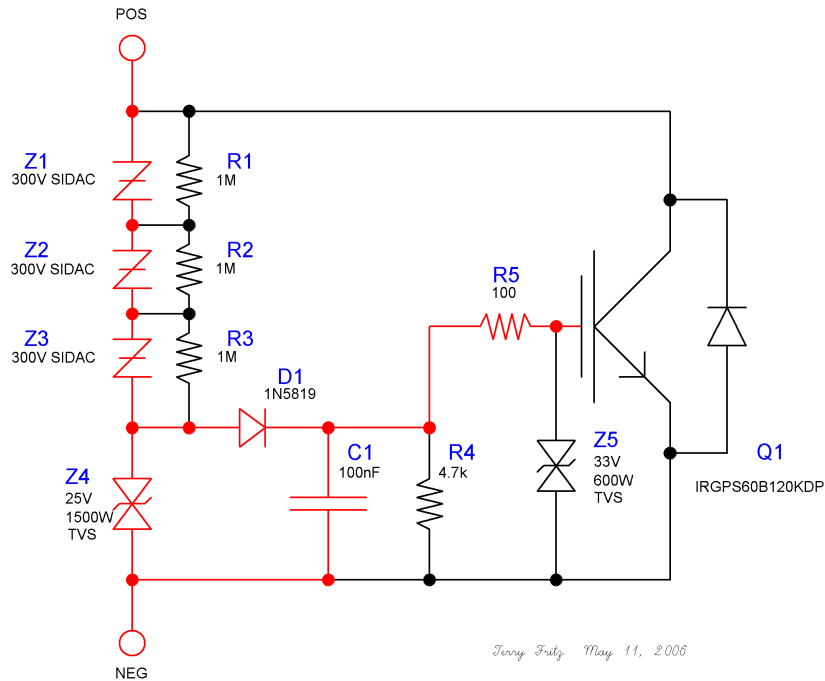

Figure 5. C1 charged and Z4 takes over current load.

Once the load is taken over by the IGBT (Figure 6), the circuit is set to run as a full shorted gap (red path). The IGBT will pass current in one direction and the anti-parallel diode will pass current in opposite direction. With the voltage across the SIDACs removed, they will eventually turn off and return to the pre-fire state.

### 900 Volt SIDAC/IGBT Solid State Spark Gap Module

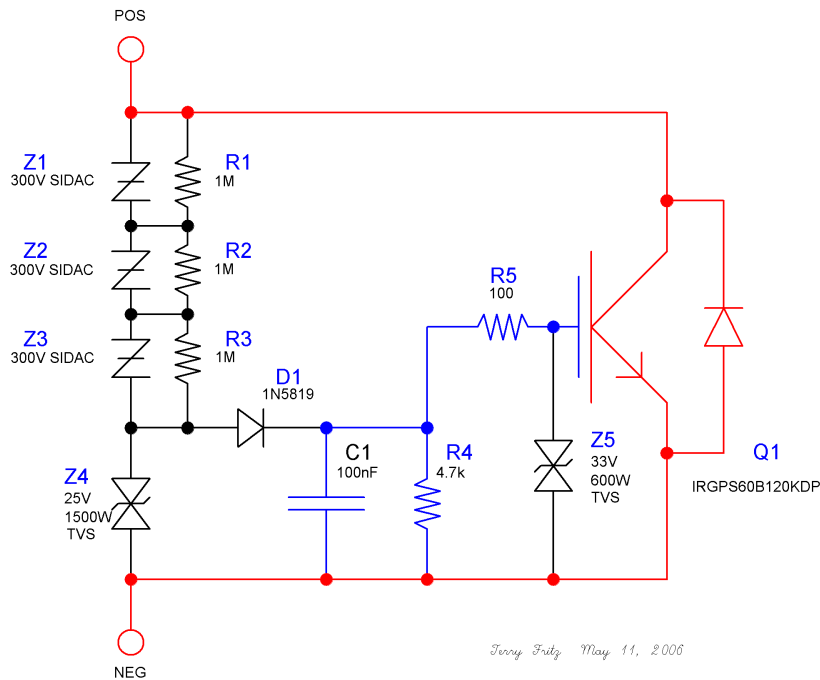

Figure 6. IGBT takes over current load.

With no current flow into the capacitor and no current drain path other than the 4.7k resistor (R4), the IGBT will stay in conduction until the gate voltage drops to about 4 volts governed by the drain path (blue). The turn-off time is as follows.

$$V = V_0 \times e^{(-T/RC)} \implies 4 = 25 \times e^{(-T / (4700 \times 104.6E-9))} \quad T = 901\mu\text{s}$$

Thus, the gap will stay in conduction long after the primary current dissipates but well before the next firing cycle. This resistor value can also be changed "at will" to adjust the "quench". The on time is  $191E-9 \times R_4$  seconds. A variable potentiometer is best here.

## COMPUTER MODELING

Computer models can be used to study SISG coils with some modifications from standard models. The circuit introduced by Gary Lau with a 555 timer circuit can control the spark gap function and turn off. A MicroSim (free student version 9.1) model is shown below. Note that the capacitor in inductor losses in the primary and secondary system are now important! With such a low loss gap, the extra energy is no longer consumed in the spark gap. In the case of a primary system being fired with no secondary system in place, The say 1000W of energy has to go "somewhere"... No longer is the spark gap the giant energy "sink"!! Heating of the inductors and primary cap in the "high loss case" may now be very significant! Normally, the vast majority of the energy should go the the streamers. But if not, be careful since it has to go somewhere, and probably no place good...

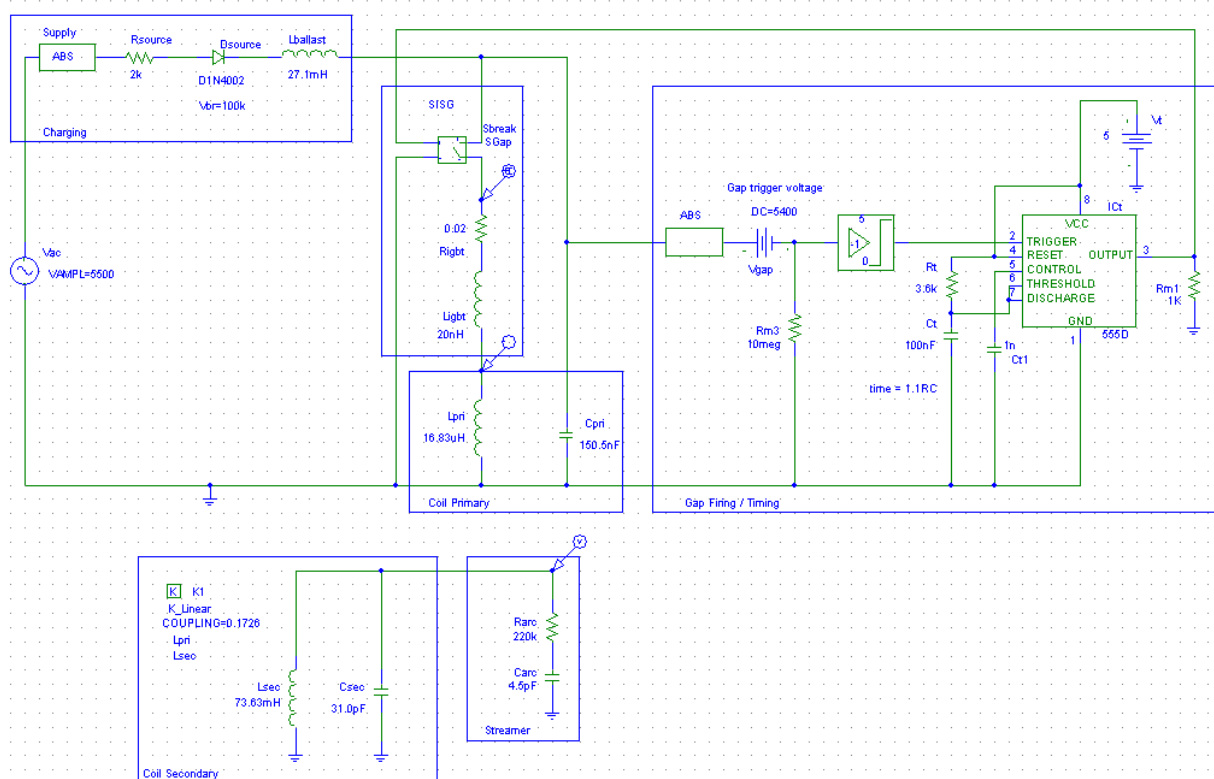

Figure 7. MicroSim SISG model.

Simple spreadsheet programs can help design and do "what if" calculations quickly. A simple spreadsheet such as show in Figure 8 is very useful.

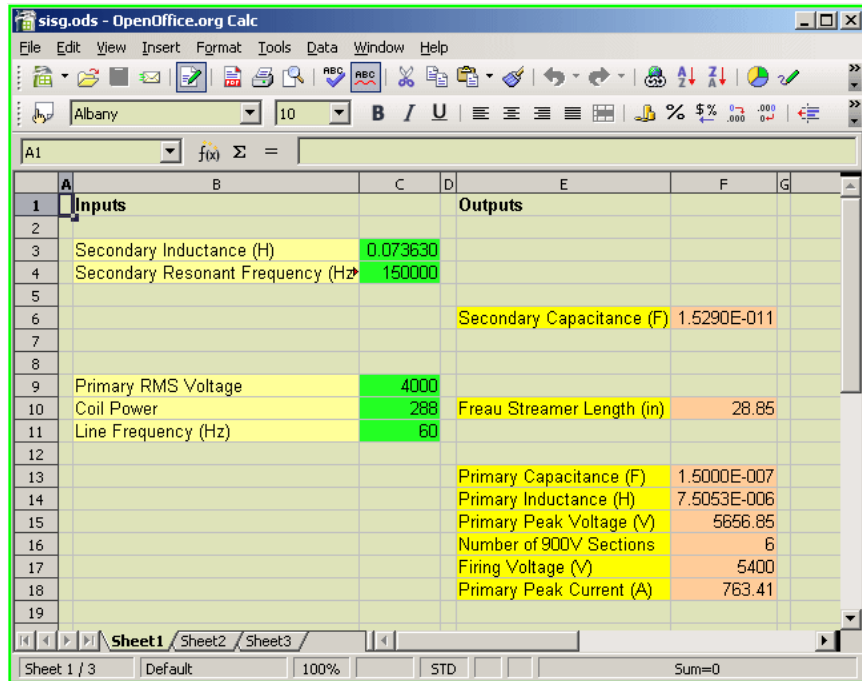

Figure 8. Simple spreadsheet program.

## TESTING

The basic single section has been tested to 800 amps with 0.02 ohms effective resistance as compared to 3 ohms of resistance for a typical spark gap. The very low resistance allows the inductance to become significant. The voltage and current graphs of the SISG's operation are shown in Figures 9 and 10.

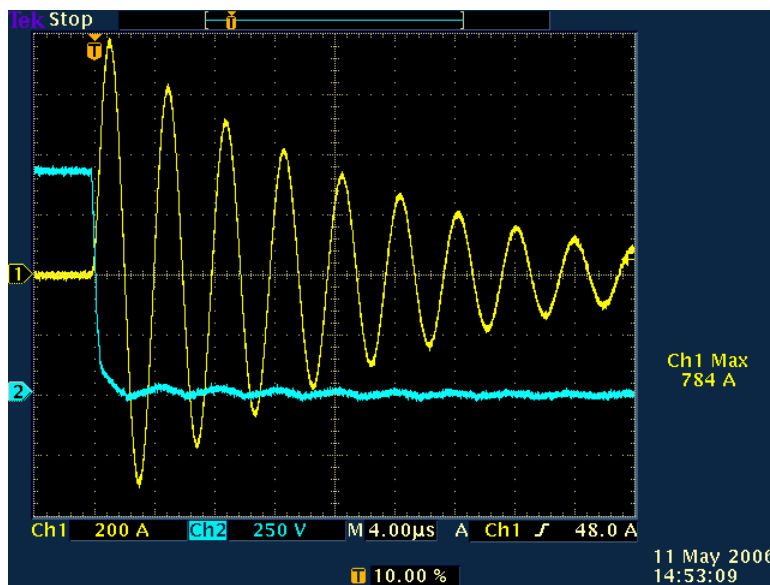

Figure 9. Current through and voltage across the SISG.

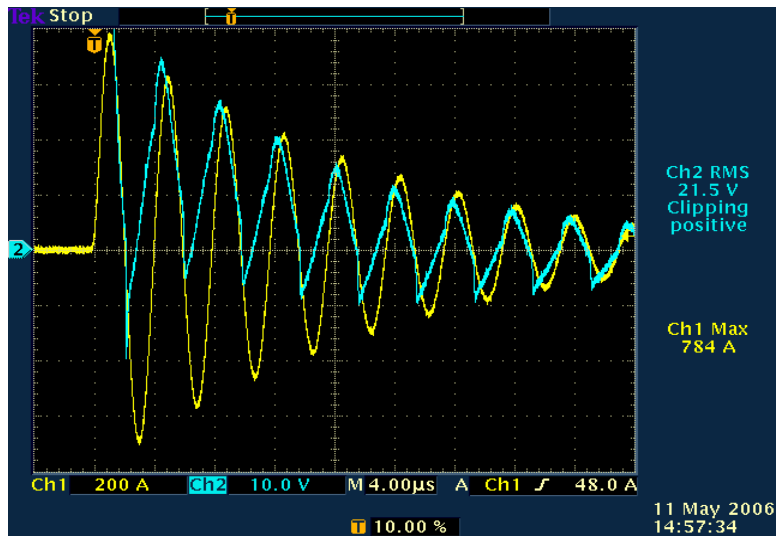

Figure 10. Current through and voltage across the SISG.

The SISG gap impedance appears as a 0.020 ohm resistance in series with a 20nH inductance. For power dissipation, each gap section dissipates the primary loop RMS current squared multiplied by 0.020 ohms.

By dividing voltage by current, instantaneous resistance can be found as shown in red in Figure 11.

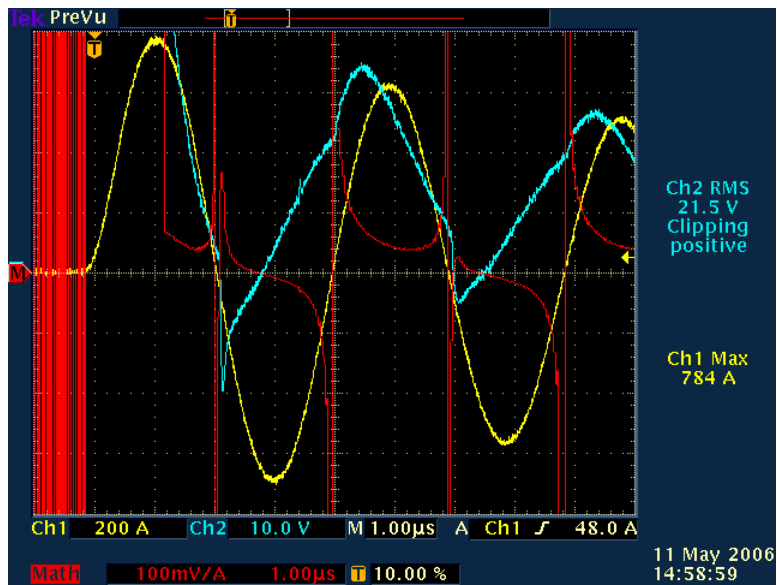

Figure 11. Dynamic resistance (red) at 0.1 ohms/div.

The gate voltage on the IGBT is rather high and can be driven up buy slow switching, emitter loop inductance, C<sub>eg</sub>, and possible streamer hits. The 33 volt TVS (Z5) limits the voltage and protects the gate of the IGBT in any case. In the graph shown in figure 12, the gate voltage is slightly "flat-topped" buy Z5.



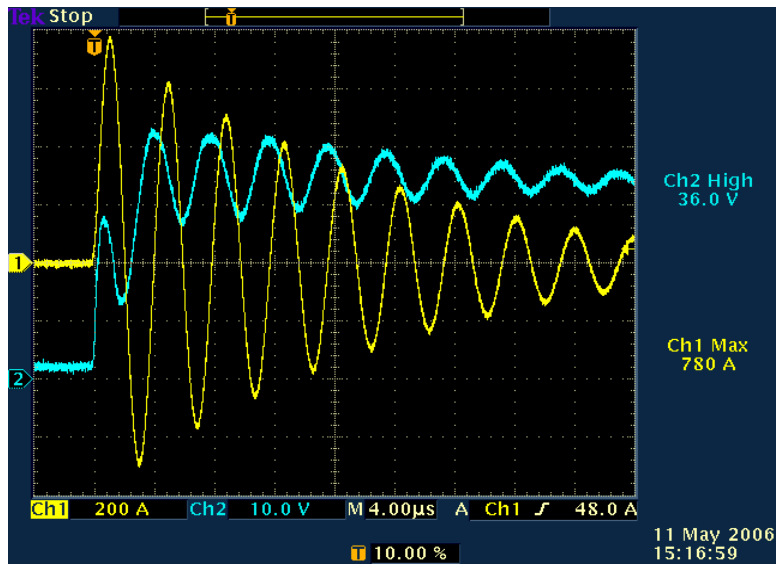

Figure 12. Gate voltage on IGBT during 800 amp operation.

As a first test, a very simple system was set up. It was not optimal and only consumed 14.6 watts of power, but it showed that the basic system could actually run and make sparks. The two prototype SISG modules were wired as shown in Figure 13.

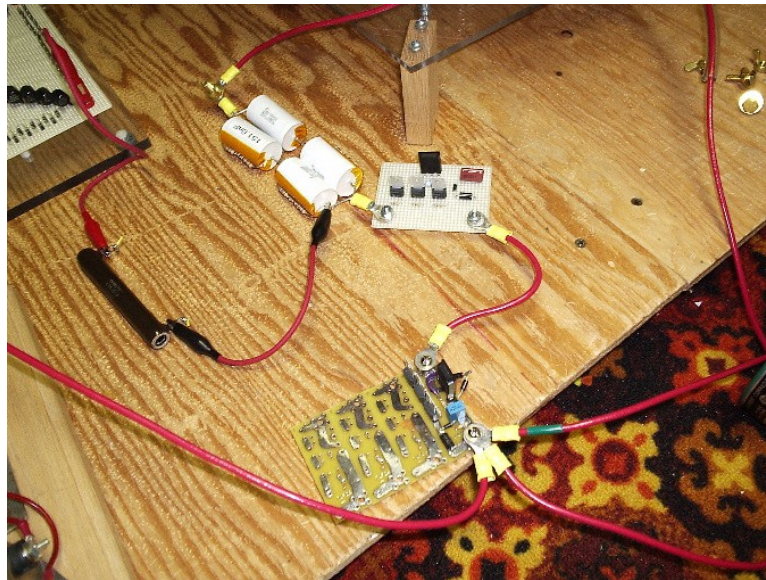

Figure 13. First coil setup with two prototype 900V sections.

Firing voltage 1800V.  
 Primary capacitance 150nF.  
 $f_0$  105kHz.  
 60 BPS.

The system could not quite breakout, so a 5 inch gap to ground was set up as shown in figure 14 and run. The system easily arc the 5 inch gap will little IGBT heating (no heatsink).

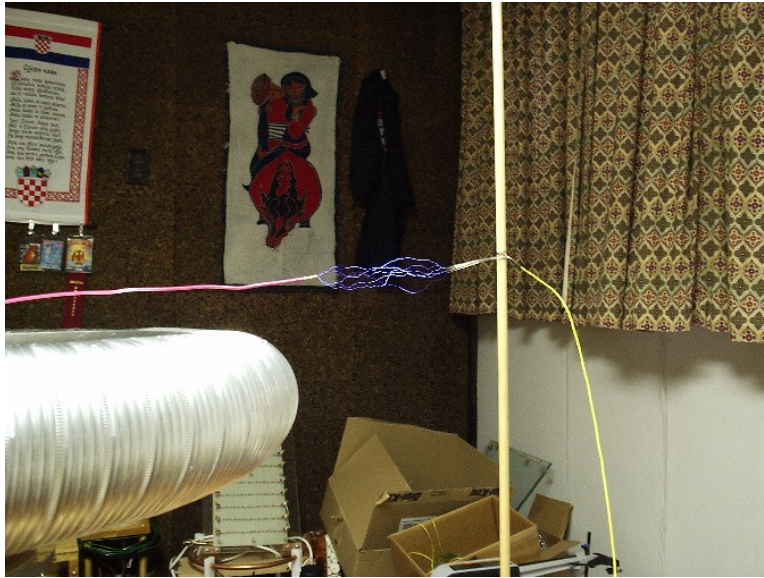

Figure 14. First light at about 14.6 watts power.

## CONSTRUCTION

A system was designed to run off two MOTs and using six SISG 900V modules for a 5400 volt firing voltage and a 150nF primary capacitor. At 120 BPS this gives 262 watts of power which should give 27.5 inch arcs according to the Freau equation. The system calculations are shown in Figure 8 and the coil system schematic is shown in Figure 15.

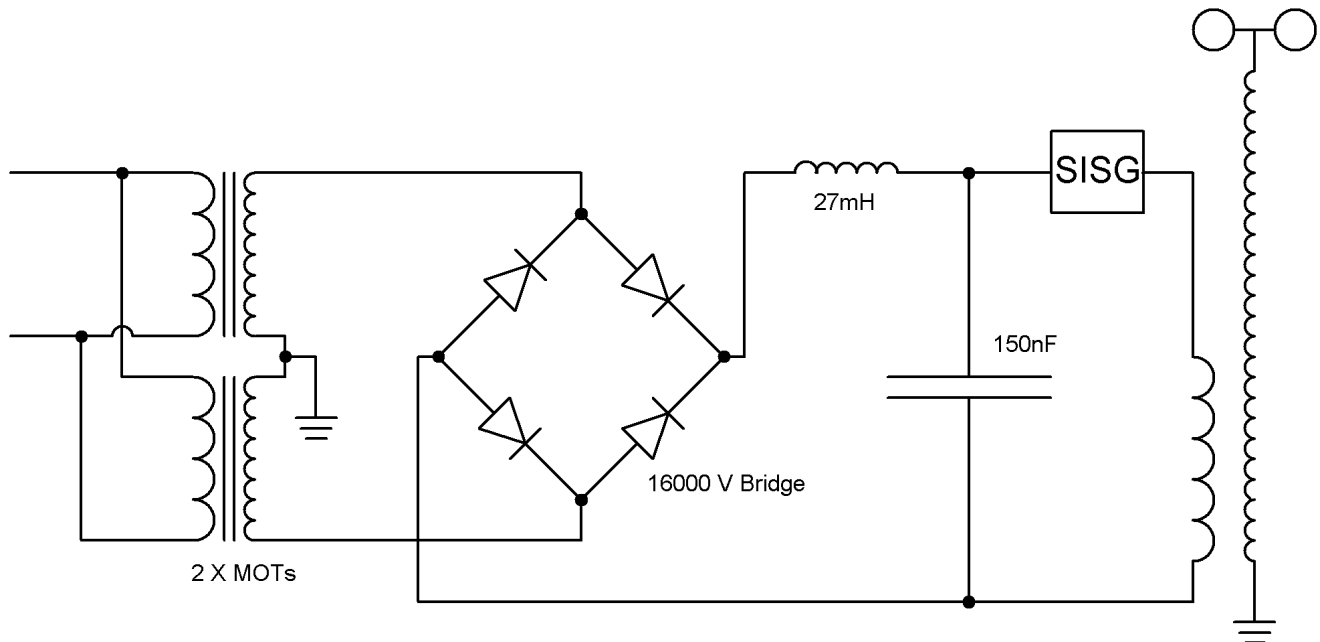

Figure 15. NEW COIL SCHEMATIC.

Pre-made PC boards from ExpressPCB were used for the modules. The board layout is shown in figure 16. The actual board is shown in Figure 17 less the IGBTs.

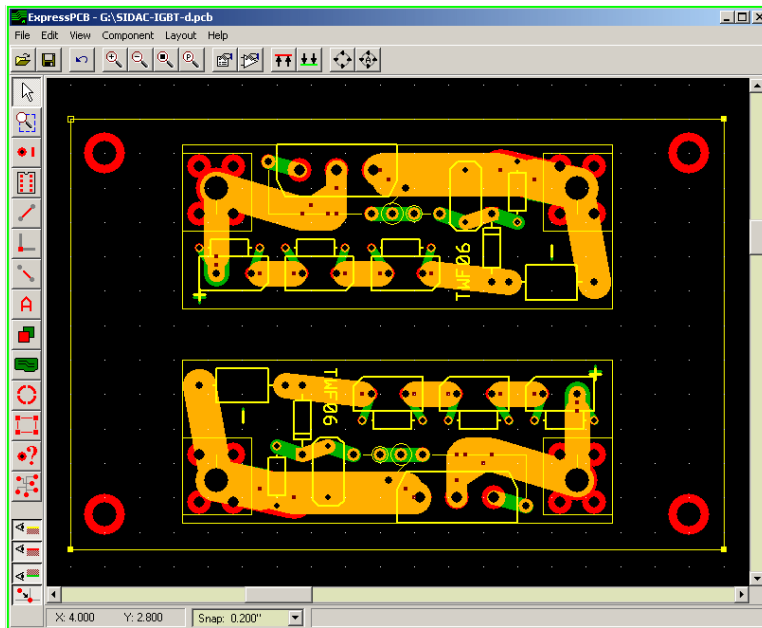

Figure 16. PC board layout for inexpensive "mini-boards".

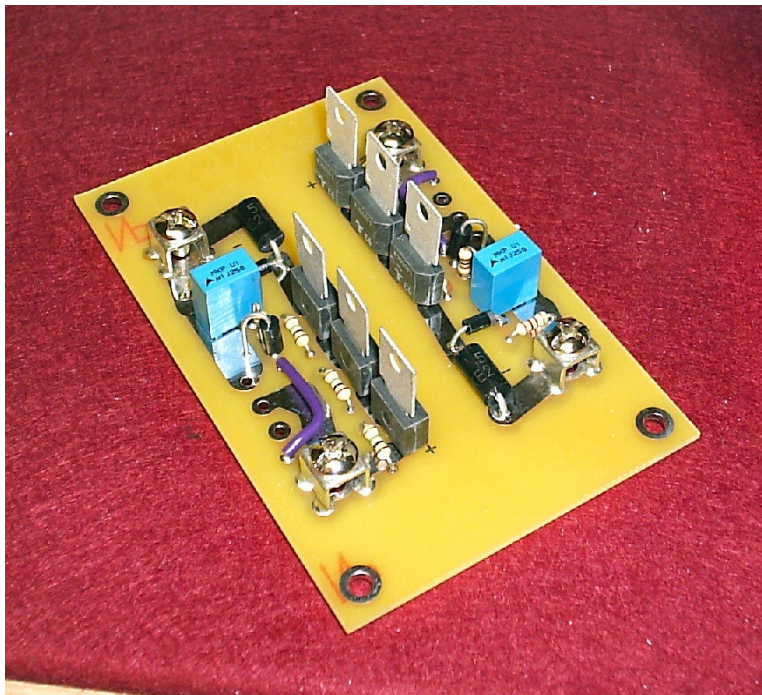

Figure 17. Actual SISG board less IGBTs.

Three boards are assembled together with interconnecting wiring to make the full gap assembly as shown in figure 18. The total voltage is 5400 volts that can be wired in 900 volt increments.

The present IGBTs use the rather odd "SUPER TO-247" package. It is hard to find a good "clip" heat sink for them but thermal glue such as: <http://www.siliconacoustics.com/arsiltherad.html> (only \$1 shipping ;-)) is a good option. Note that a fan will increase thermal dissipation by at least 5X.

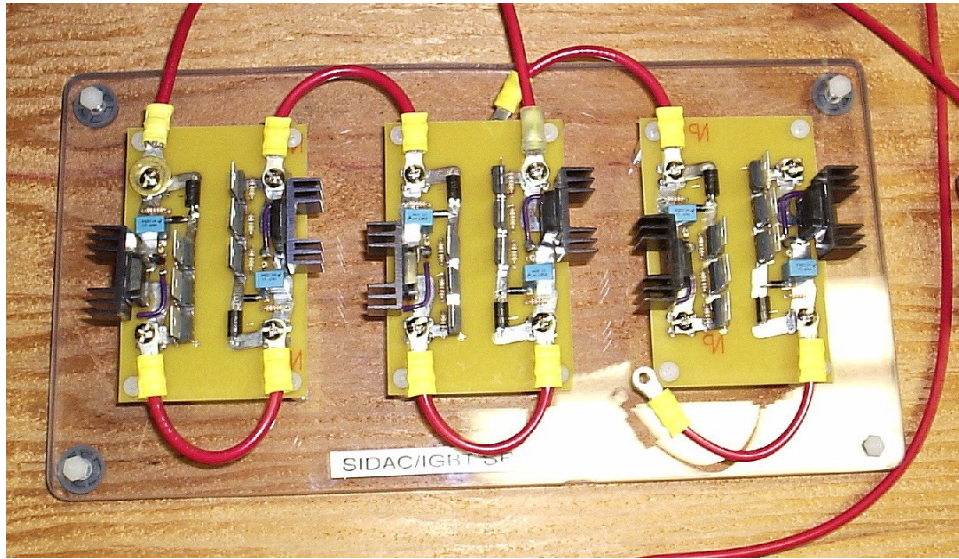

Figure 18. Full SISG assembly with six 900V sections.

The other parts such as MOTs, MMC, rectifier and ballast are show in Figure 19.

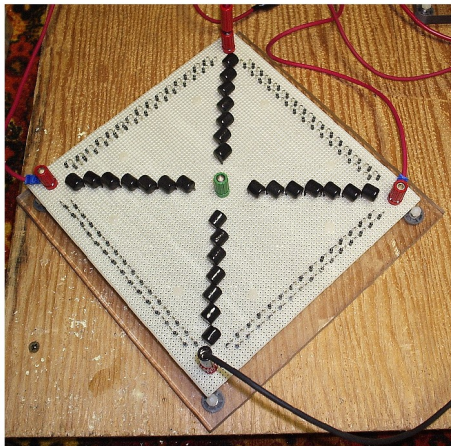
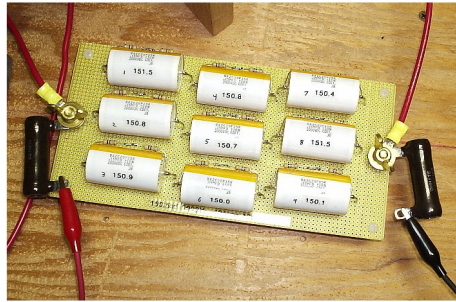
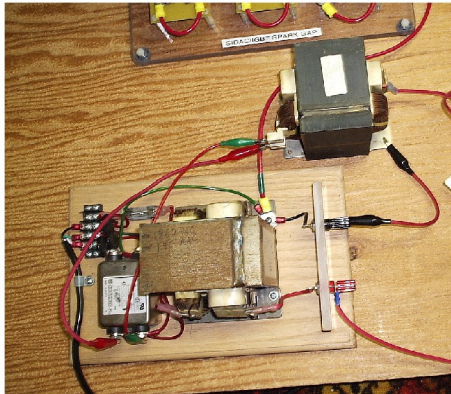

Figure 19. MOTs, MMC, rectifier and ballast.  
The entire coil system is shown in Figure 20.

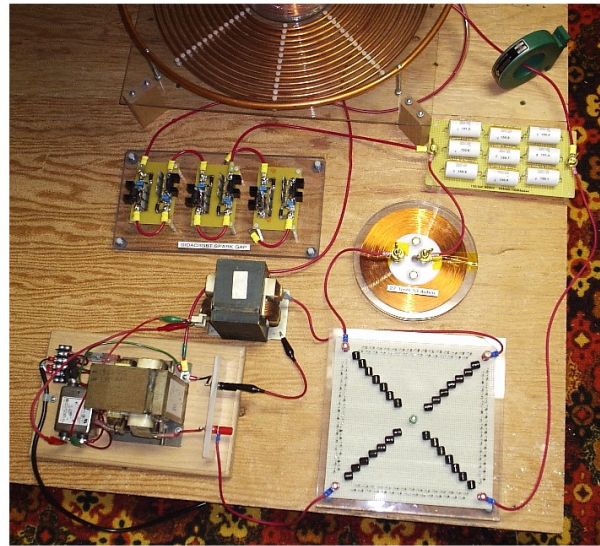
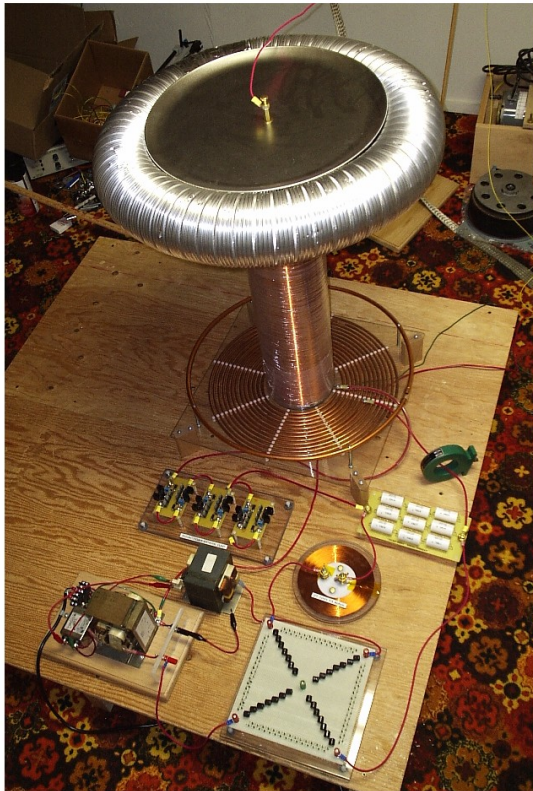

Figure 20. Entire coil system.

### Specifications:

#### Primary

ID = 6.8"  
 OD = 17.2"  
 Pitch = 0.4"  
 1/4" copper tubing  
 $L = 16.57\mu\text{H}$  (~7 turns)  
 $C = 150.5\text{nF}$   
 Coupling = 0.1726  
 $F = 100.8\text{kHz}$

$I_{\text{peak}} = 512$  Amps  
 Bang Energy = 2.19 Joules

#### Secondary

Dia. = 6"  
 Length = 20"  
 1363 turns  
 #28 wire  
 $R_{\text{ac}} = 460$  Ohms  
 $C = 31.1\text{pF}$   
 $L = 73.63\text{mH}$   
 $F = 105.2\text{kHz}$

$I_{\text{Prms}} = 22.7$  Amps  
 System power = 263 Watts

### Testing:

One May 21, the system was run at 3600 volts and achieved 23 inch arcs to ground. The system power was 117 Watts.\*

I would count on the ringdown time being without any streamer load and adjust R4 for the longer time. I am using 2.2k for 400uS.

Also, I found that if you turn up the voltage too high on a MOT system the gap will fire at say 480BPS rather easily as opposed to 120BPS. That increases heating 4X (!) without much increase in streamer length at all.\*

I have very small ~1 inch square heatsinks and they stay reasonably cool. But one should consider larger ones or go to fan cooling in many cases.

May 22, 2006

With more time, the system can fairly easily hit 24 inches at 117W - and 30 inches at 183W. The Freau number there is 2.22 in both cases. That number seems very "constant".\*

I was only able to go to 5 sections instead of six due to the limited safety area in my basement. With six sections, it should get to 263 watts for 36 inches.\*

The little heat sinks get to about body temperature for short runs which is just right according to the calculations. Bigger heat sinks and/or a fan would be good for extended operation.

You have to be careful to turn up the variac until it just starts to run smoothly (120 BPS) and no more. If you turn up the voltage too high, the BPS rate can go up dramatically and overheat the IGBTs. Higher BPS does not seem to increase spark length other than making them sound funny. Sort of "screechy".\*

BTW - The dual MOT system has an extremely dangerous primary system!! Be very careful when working on them especially now that there are electronic circuits and stuff in there to fiddle with. Be ultra sure that the power is off before working on them. Be very careful of the output arcs since it is possible for a primary to secondary break over to present lethal currents on the secondary. Note too that the primary circuit can be almost at full power, but totally silent!

Figure 21 shows 30 inch arcs to ground with 5 sections firing at 4500 volts and 183 watts.\*

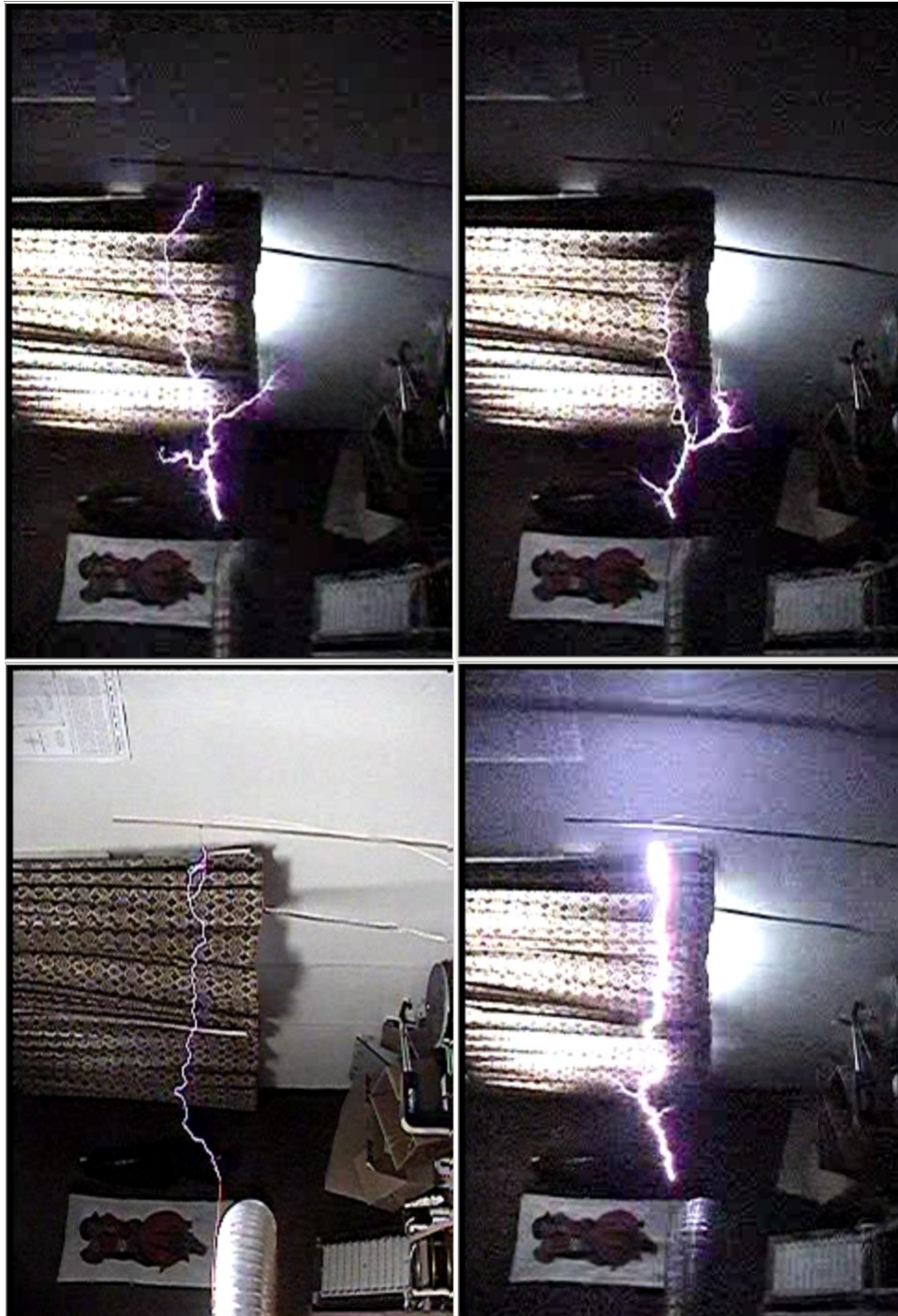

Figure 21. 30 inch arcs to ground at 183 watts.

For my 183 watt test, the RMS primary current is 11 amps, so the power in the five sections is 12 watts total. Thus, the gap is losing about 6.6% of the total coil energy. The only other major loss would be in my big secondary made from #28 wire that probably dissipates 8 watts as heat. So with 183 watts in, about 163 watts is making it to the streamer for an efficiency of 89%. That would actually place an upper limit on the Freau value of 2.35.\*

May 28, 2006

\*Note: It has been found that the system firing is fairly chaotic. Thus the power levels and Freau numbers are not well established.

I am no longer confident in the Freau numbers I gave before at all... It runs real good, but I would like it to be a stable 120BPS... Probably all the chokes, rectifiers, caps, etc. messing around with each other... The primary current is probably much higher than I thought which is good since the IGBT heating will be even less than expected ;-)

I was able to look at the top voltage today and managed to get ScanTesla and MicroSim simulations to match as shown in Figure 22.

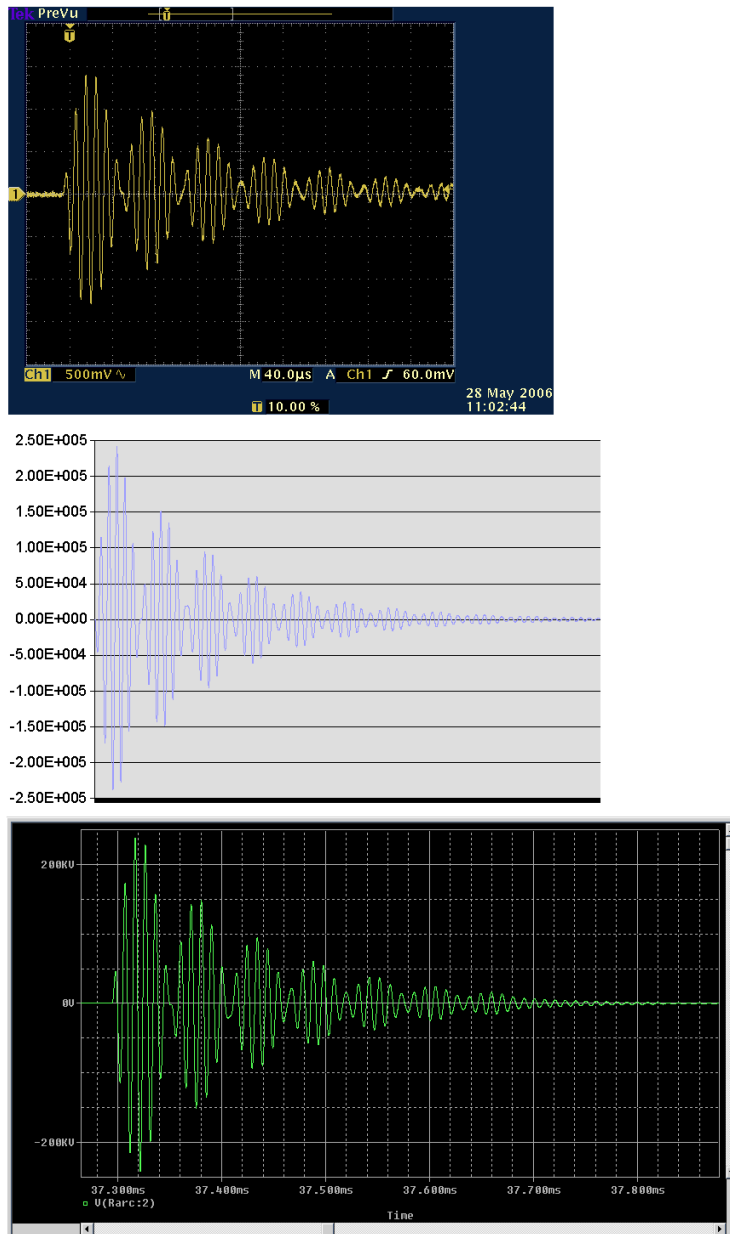

Figure 22. Actual, ScanTesla, and MicroSim simulations



I also looked at ground strikes. It is interesting that after the secondary system is drained of energy, the primary system is now able to recharge it a bit as shown in Figure 23.

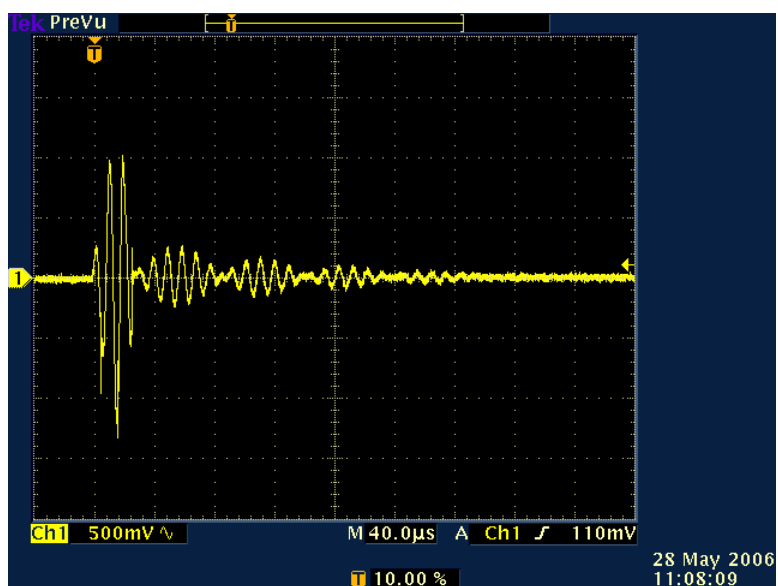

Figure 23. Secondary voltage during a ground strike.

Many thanks to members of the Pupman Tesla Coil Builder's List and Members of 4HV for help, ideas, and encouragement!!!

<http://www.pupman.com>

<http://www.4hv.org>

Note: The SISG design presented here is fully and completely released to the Public Domain.