

How to Make — and Use A Small Chemical Laboratory

A BOOK FOR BEGINNERS SETTING FORTH THE
FUNDAMENTALS OF CHEMICAL SCIENCE IN
UNDERSTANDABLE TERMS. INCLUDES
INSTRUCTIONS FOR BUILDING AND
USING A SMALL HOME LABORATORY.

By

RAYMOND FRANCIS YATES



Illustrated with specially made engravings, showing
construction and use of chemical apparatus.

PDF by Mr White 21 March 2002 enjoy and share

NEW YORK

THE NORMAN W. HENLEY PUBLISHING COMPANY

2 WEST 45th STREET

1926

INDEX PAGE 88

PREFACE

This little book has been prepared for those who wish to become acquainted with the great fundamentals of chemistry. The author resolved at the beginning not to write the treatment in the prescribed "text book" way, and it was therefore decided to explain the Electron Theory as an introduction to the study of inorganic chemistry.

The Electron Theory has done much to make chemistry a more vitally interesting subject. It is a new philosophy that has brought the science of chemistry to a more understandable basis. It offers explanations to many phenomena that up until a few years ago were absolutely mysterious. Today, chemists speak in terms of the Electron Theory, and nobody desirous of entering into the study of chemistry should neglect to become familiar with its outstanding features at least. These, the author has attempted

to outline in common terminology.

The second part of the little book has been devoted to the construction of the home laboratory. Such things as can be made by the amateur chemist are described in a way that will enable him to build them with a minimum of trouble.

The third portion of the book has been given over to chemical experiments. Experiments have been chosen that will give the reader a broader understanding of chemical science in general. These experiments also cover the various phases of chemistry.

This book will only serve as an introduction to the study of chemistry. The author has endeavored to explain the fundamentals in an understandable way so that the student, upon completing this treatment, will be able to start the study of chemistry from a more elaborate book without becoming confused and discouraged, as many do.

RAYMOND FRANCIS YATES.

TABLE OF CONTENTS

PART I

INTRODUCTION TO THE STUDY OF CHEMISTRY

Elements and Compounds—Chemical Symbols—Molecules—Atoms—Electrons—How Electrons Form Atoms—Explanation of Chemical Activity—Chemical Formulas—Speed of Chemical Reactions—Physical and Chemical Changes—The Law of Definite Proportions—Different Kinds of Chemical Reaction—Classification of Chemical Compounds—The Law of Combining Weights—Solutions—Acids and Bases—Neutral Substances—Organic and Inorganic Chemistry—Electrochemistry—Experiments in Electrochemistry. *Pages 7-39*

PART II

EQUIPPING A SMALL CHEMICAL LABORATORY

Method of Obtaining Heat—Bottles—A Chemical Balance—Test Tube Racks—A Ring Stand—A Hydrogen Sulphide Generator—Necessary Apparatus—Test Tubes—Evaporating Dishes—Fire Clay Crucibles—Filter Paper—Graduated Cylinder—Chemical Thermometers—Pipette—Red and Blue Litmus Paper—Beakers—Pinch Cocks—Thistle Tubes—Flasks—Clamps—Chemicals for the Laboratory. *Pages 40-62*

PART III

CHEMICAL EXPERIMENTS

Preparation of Oxygen—Breaking Glass Tubing—Catalytic Agents—Experiments with Oxygen—Production of Chlorine—Experiments with Chlorine—Neutralization—Distillation of Water—Practical Distillation—Thermit—A Small Electric Furnace—Furnace Connections—Experiments in Catalysis—Negative Catalysis—Detecting the Presence of Carbon Dioxide—Production of Calcium Carbonate—Electrolytic Production of Lead Carbonate—Production of Nitric Acid—Colloidal State of Matter—Crystalloidal and Colloidal Solution—Electrolysis of Water—Generation of Hydrogen in Quantities—Glass Working for Amateur Chemists—Cutting and Breaking—Drilling—Smoothing Rough Edges—Bending Glass Tubing—Cutting Glass Tubing—Drawing Glass Jets—Sealing a Platinum Wire in Glass—Joining Tubing and Making Tees—Spreading the Ends of Tubing—Glass Spiral Tubes—Miscellaneous Information. *Pages 63-97*

How to Make and Use a Small Chemical Laboratory

PART I

INTRODUCTION TO THE STUDY OF CHEMISTRY

Elements and Compounds—Chemical Symbols—Molecules—Atoms—Electrons—How Electrons Form Atoms—Explanation of Chemical Activity—Chemical Formulas—Speed of Chemical Reactions—Physical and Chemical Changes—The Law of Definite Proportions—Different Kinds of Chemical Reaction—Classification of Chemical Compounds—The Law of Com-

binning Weights—Solutions—Acids and Bases—Neutral Substances—Organic and Inorganic Chemistry—Electrochemistry—Experiments in Electrochemistry.

Many people are inclined to regard chemistry as one of the more occult sciences. Of course, it must be admitted that the science of chemistry has many ramifications, but the study and practice of ordinary inorganic chemistry is quite within the range of any person with enough ambition to master the essentials.

ELEMENTS AND COMPOUNDS

The study of chemistry is generally started by an understanding of the words "element" and "compound." Scientists have found that this world of ours, as great as it is, is merely composed of eighty odd elements or basic substances. There is a great difference between an element and a compound. If

8 a chemist takes a quantity of water to analyze, he finds that he is able to break the water up into two gases, i.e., hydrogen and oxygen. These two gases, when separated, resist any further attempts to be "divided." That is, they are basic substances—they are elements. A compound, then, is a combination of elements. Water is a compound because it is composed of oxygen and hydrogen. Iron is an element because, we might say, it is composed of nothing but iron—the chemist is not able to break up the iron into any other constituents.

It was stated before that there are but eighty different elements in the whole world. However, these eighty odd elements combine in different proportions to form many thousand compounds. The physical and chemical properties and characteristics of the compounds formed are entirely different from those of the individual elements which go to make up the compound. For instance, water is a liquid, but its constituents are the gases hydrogen and oxygen.

Some of the elements are gaseous, some solid and a few liquid. The list of chemical elements—elements of the whole world—follows:

	Symbol	Combining or atomic weight		Symbol	Combining or atomic weight
Aluminum	Al	27.1	Columbium	Cb	93.5
Antimony	Sb	120.2	Copper	Cu	63.57
Argon	A	39.88	Dysprosium	Dy	162.5
Arsenic	As	74.96	Erbium	Er	167.7
Barium	Ba	137.37	Europium	Eu	152.0
Bismuth	Bi	208.0	Fluorine	F	19.0
Boron	B	11.0	Gadolinium	Gd	157.3
Bromine	Br	79.92	Gallium	Ga	69.9
Cadmium	Cd	112.40	Germanium	Ge	72.6
Calcium	Ca	40.07	Glucinum	Gl	9.1
Carbon	C	12.00	Gold	Au	197.2
Cerium	Ce	140.25	Helium	He	3.99
Cesium	Cs	132.81	Hydrogen	H	1.008
Chlorine	Cl	35.46	Indium	In	114.8
Chromium	Cr	52.0	Iodine	I	126.92
Cobalt	Co	58.97	Iridium	Ir	193.1

9

Symbol	Combining or atomic weight	Symbol	Combining or atomic weight
Iron	Fe 55.84	Ruthenium	Ru 101.7
Krypton	Kr 82.92	Samarium	Sa 150.4
Lanthanum	La 139.0	Scandium	Sc 44.1
Lead	Pb 207.10	Selenium	Se 79.2
Lithium	Li 6.94	Silicon	Si 28.3
Magnesium	Mg 24.32	Silver	Ag 107.88
Manganese	Mn 54.93	Sodium	Na 23.00
Mercury	Hg 200.6	Strontium	Sr 87.63
Molybdenum	Mo 96.0	Sulphur	S 32.07
Neodymium	Nd 144.3	Tantalum	Ta 181.5
Neon	Ne 20.2	Tellurium	Te 127.5
Nickel	Ni 58.68	Terbium	Tb 159.2
Niton (radium emanation) ...	Nt 222.4	Thallium	Tl 204.0
Nitrogen	N 14.01	Thorium	Th 232.4
Osmium	Os 190.9	Thulium	Tm 168.5
Oxygen	O 16.00	Tin	Sn 119.0
Palladium	Pd 106.7	Titanium	Ti 48.1
Phosphorus	P 31.04	Tungsten	W 184.0
Platinum	Pt 195.2	Uranium	U 238.5
Potassium	K 39.10	Vanadium	V 51.0
Praseodymium ..	Pr 140.6	Xenon	Xe 130.2
Radium	Ra 226.4	Ytterbium	Yb 172.0
Rhodium	Rh 102.9	Yttrium	Yt 89.0
Rubidium	Rb 85.45	Zinc	Zn 65.37
		Zirconium	Zr 90.6

CHEMICAL SYMBOLS

After each of the elements in the above list will be found a letter or symbol which chemists use in place of writing the entire word out. In place of writing out the word hydrogen, merely the first letter, H, is used. This may be called the shorthand method of chemical expression and the symbol for all of the common elements should be memorized by the amateur chemist. Upon referring to the list it will be seen that the symbol for some of the elements is composed of two letters, and that these two letters in no way correspond to the letters in the word. Sodium is represented by the letters Na, and mercury by Hg. Many of the elements start with the same letter, and if this letter was used for each element, it

10

would lead to confusion. Therefore, the first two letters of the Latin name are used. Cu, which represents copper, is taken from the Latin *cuper*. In some cases only the first letter is employed.

MOLECULES

Before going farther with the study of chemistry it will be well to understand the terms molecule, atom and electron. The molecule is composed of two or more atoms, usually of different compounds. Water, which is composed of hydrogen and oxygen, has a molecule made up of two atoms of hydrogen and one atom of oxygen. Molecules, however, are not always associated with compounds. There are a few elements that have a molecule which is made up of two or more of their own atoms.

Molecules are extremely small. In fact, they are far beyond the range of the most powerful optical instruments of magnification. Molecules are generally measured in the millionths of an inch. Some molecules are composed of two atoms and some of many hundred atoms. Of course, those containing many hundred atoms are much larger than those with a smaller number.

ATOMS

If molecules are made up of atoms and molecules are measured in the millionth of an inch, we can readily appreciate the fact that the atom must be a much smaller particle. This is quite true. The reader will understand that compounds do not have atoms in the sense that an element has atoms. True, the ultimate constituent of a compound is the atom, but owing to the fact that the atoms are grouped together

11

to form molecules, chemists are inclined to regard a compound as being made up of molecules rather than atoms. This will be made more clear later.

We are now aware of the fact that a molecule is composed of two or more atoms and that the atom is that infinitesimal particle that goes to make up elements. Thus, we have the atom of sodium, the atom of potassium, the atom of copper, etc. We cannot say, however, that we have the atom of water because water is made of two elements in combination. In place of atom, the term molecule is used.

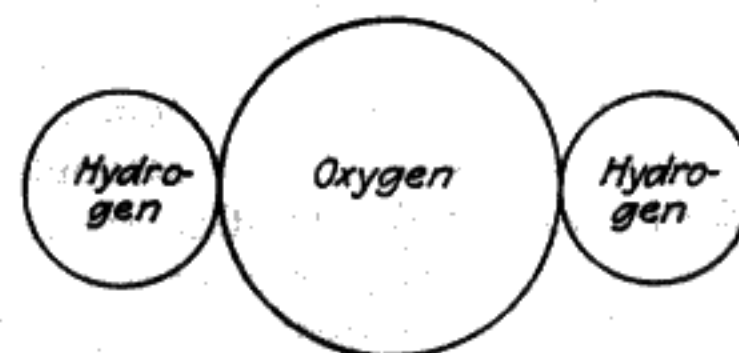

Fig. 1.—A Diagrammatic Representation of a Molecule of Water.

A molecule of water is pictured diagrammatically in Fig. 1. It will be seen that the atom of oxygen is really larger than the atom of hydrogen. It will also be seen that there are two atoms of hydrogen to one atom of oxygen. Upon referring to the list of elements, it will be seen that the atomic weight of oxygen is greater than the atomic weight of hydrogen. Owing to the fact that atoms are all made up of the same particles—electrons, which we will consider later—it will be understood that the elements with the heaviest atomic weights must be the largest. The chemical expression for water is written H_2O . This means that there are two atoms of hydrogen and one atom of oxygen. The figure two after the H signifies the number of hydrogen atoms in the compound. The subject of

12

the chemical expression of formulas will be taken up more in detail later.

ELECTRONS

At this point we are ready to consider the last and ultimate constituent of matter—the electron is ushered in. The electron is really a comparatively recent discovery of science. It is responsible for the Electron Theory which would seem to reduce the phenomenon of the whole world to a purely electrical problem.

HOW ELECTRONS FORM ATOMS

The electron is absolutely the smallest particle. It goes to make up atoms. Each atom has an identity. We have atoms of copper, iron, etc. All electrons are the same. Just as atoms in various numbers form molecules, electrons in various numbers form atoms. However, we cannot draw a distinct parallel between the two classes.

The electron is really a unit of negative electricity. It has a mass of 1/1700ths that of an atom of hydrogen, which, as a glance at the list of chemical elements will show, is the smallest and lightest atom. It may confuse many readers to think somewhat vaguely of an electron being a "unit of negative electricity." However, this is about the best explanation that can be given. In a strict sense, the electron cannot be considered as matter. The single electron we must accept as a unit of mysterious "something" which we have called negative electricity. Atoms are composed of various numbers of electrons. Each atom has a specified number of electrons. Thus, each element has a certain identity.

Are we to picture the atom as being composed of

13

a specified number of electrons arranged in a haphazard manner? Not so. In fact, we know that "like charges of electricity repel one another and dislike

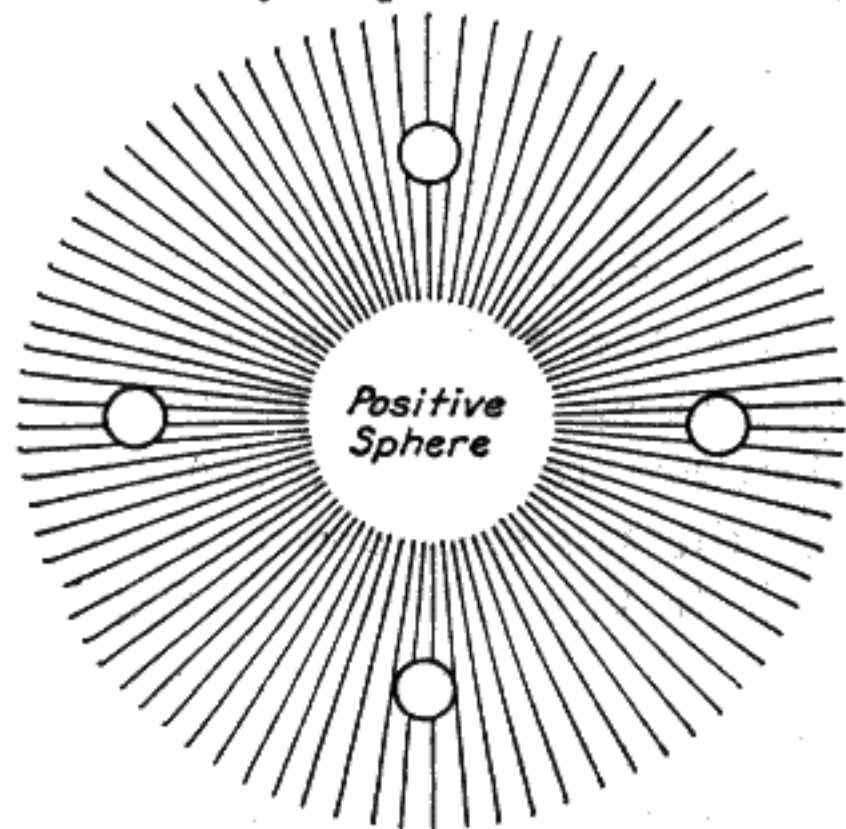

Fig. 2.—The Electrons of an Atom are in a Sphere of Positive Electricity. The Lines in the Diagram Represent This Sphere of Positive Electricity.

charges attract one another." With this fact in mind, then, how can we think of our hypothetical atom as being made up of electrons when these electrons are negative units of electricity and when negative charges repel one another? If this was the case, our hypothetical atom of electricity would soon dissipate.

The electron theory describes an atom as a particle composed of a definite number of electrons or negatively charged units revolving about a sphere of positive electricity. Of course, this "sphere of positive electricity" is just as much a mystery to us as the electron itself. Nevertheless, it furnishes us with a reasonable hypothesis. If dislike charges of electricity attract one another, then the sphere of positive electricity which forms the nucleus of the atom will cause

14

the electrons, which are units of negative electricity, to remain in proximity to the nucleus.

A very crude diagram which is intended to represent at least the arrangement of the electrons in an atom is shown in Fig. 2. It must be remembered that every atom of oxygen, for instance, has exactly the same number of electrons. This is true of all the atoms of the different elements. From this we see that each chemical element is different because it contains a certain number of electrons in its atom. All matter must be regarded as being composed of electrons; these electrons are grouped into atoms and the atoms into molecules.

From the above information, we assume, then, that each atom is in an electrically neutral condition. If the positive charge is strong enough to bring about an electrical equilibrium, this would be the case. Let us, for the moment, assume that this is the case. We will picture a group of electrons held about the nucleus of an atom with neither the positive electricity of the nucleus nor the negative electricity of the electrons predominating. We will say that we have an electrical equilibrium. What if one electron was in some way to escape from the atom? The equalization of charges or the equilibrium would then be destroyed and the positive charge would predominate. Again, we can imagine one hypothetical atom coming in contact with another atom, the second atom losing an electron which is immediately picked up by the first atom. Investigation has proven that this interchange of electrons actually does take place.

Let us review what we have said concerning the electron theory a little more thoughtfully. The importance of the theory to present-day science justifies this.

If we were to arrange all of the elements in the

15

list shown on pages 8 and 9 according to their atomic weight, starting with hydrogen as one because it is the

lightest, and giving the second place to the next heaviest, and so on, part of the list would be as follows: Hydrogen, 1; Helium, 2; Lithium, 3; Glucinum, 4; Boron, 5; Carbon, 6; Nitrogen, 7; Oxygen, 8; Fluorine, 9; Neon, 10; Sodium, 11; Magnesium, 12; Aluminum, 13; Silicon, 14; Phosphorus, 15; Sulphur, 16; Chlorine, 17; Argon, 18; Potassium, 19; Calcium, 20; Scandium, 21; Titanium, 22; Vanadium, 23; Chromium, 24; Manganese, 25; Iron, 26; Cobalt, 27; Nickel, 28; Copper, 29; Zinc, 30, etc., etc. Here the elements are arranged according to their atomic weight, so if copper, for instance, occupies the twenty-ninth place, we will call 29 the atomic number of copper. Thus the atomic number of carbon will be 6, that of Fluorine, 9, etc. We must remember not to confuse this *atomic number* with *atomic weight*, although it is related to it in a certain respect.

EXPLANATION OF CHEMICAL ACTIVITY

A young English scientist recently promulgated the theory that the atomic number corresponds with the electro-positive charges that form the nucleus of any atom. In other words, if the atomic number corresponds to the number of units of positive electricity that go to make up the atomic nuclei, there must be one electron or negative unit. Thus, the hydrogen atom contains one electron, the helium atom two electrons, lithium three electrons and so on through the entire list.

By themselves, we remember, electrons would repel each other, but in the presence of positive charges, they show a disposition to arrange themselves in definite groups or configurations. If hydrogen has

16

but one electron, how does it conform to any particular systematic arrangement? This does not necessarily interfere with the hypothesis we have in mind. We can picture the hydrogen atom as being made up of one charge of positive electricity and one electron. The lone electron which goes to make up the hydrogen atom is ever trying to form a pair and therefore the atoms group into molecules and hydrogen is one of the elements that has a molecule.

Let us consider the second element or helium, which has an atomic number of two. We understand that

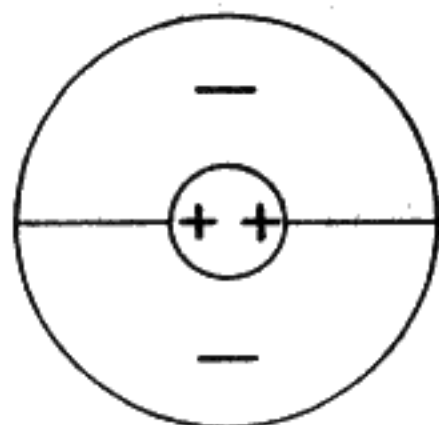

Fig. 3.—How the Electrons and Charges in an Atom of Helium are Arranged.

this element has two positive charges to form its nucleus and therefore two electrons to counterbalance these charges. The atom of helium can be pictured as shown in Fig. 3. The + marks represent the positive charges and the — marks the electrons. Here we have the ideal atom, with the electrons ideally arranged and electrically balanced. As a result, helium is an extremely inactive element. Chemists call it inert. It shows absolutely no disposition to enter into chemical relationship with any other element. Why should it? It is electrically balanced—it neither wants to gain nor lose electrons.

Let us pass on to the gas neon. Neon, although 9 places from helium in the list of atomic numbers, is

17

next to it in point of stability or chemical inactivity. It is another of the inert elements. Neon has ten electrons in its atom. We remarked some time ago that the electrons tended to arrange themselves systematically about the positive charges of a nucleus. Here we have 10 electrons. Let us see how they would arrange themselves, in the light of our theory. The first two electrons arrange themselves about the nucleus the same way as the two electrons in the atom of the helium atom. The remainder, in the words of the theory, show a disposition to group themselves

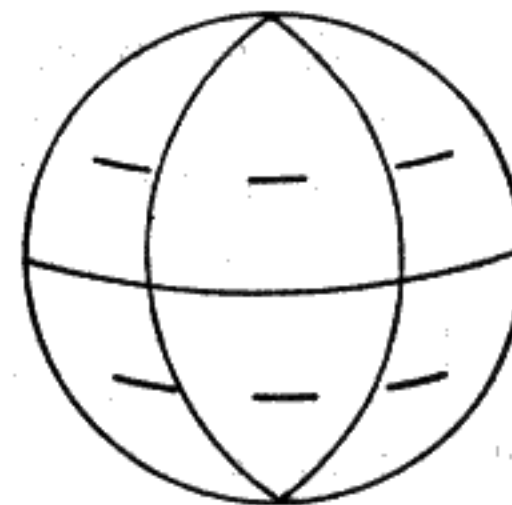

Fig. 4.—Electrons Show a Disposition to Group Themselves in Octets as Shown.

into octets, as shown in the drawing Fig. 4. Thus, each electron has a little "cell" of its own, we may say. In the atom of neon, we have a pair of electrons and an octet, all balanced, all filling every available space, and, as a result, there is no chemical activity to neon. Like helium it is inert. Neon has an ideally arranged atom. In this way the Electron Theory accounts for chemical inactivity.

Fluorine has the atomic number 9. Let us see what happens now. We can readily understand that the nine electrons of fluorine cannot arrange themselves as did the ten electrons contained in the atom of neon. We do know, however, that they will tend

18

to arrange themselves in the same way. All electrons tend to assume the same general arrangement. We assume that the nine electrons form themselves in the same way. There is one space in the octet, however, that remains unfilled. This empty space ac-

counts for the extreme chemical activity of fluorine, as we shall soon see. Fluorine has two electrons about its nucleus just as neon does. The other seven electrons are in the outer shell or octet, leaving one space unoccupied—one electron is lacking to make the octet complete. In this condition, the atom of fluorine is not favored with a stable electrical condition. It needs one more electron to make it stable. The cumulative effect of its seven outside electrons to form an octet is so great as to give the element fluorine an intense chemical activity. In fact, fluorine is a very active element. We might say that its atom has an intense appetite for one more electron to complete its octet. We can also understand that the atom of fluorine is electro-positive in nature as it is constantly in need of one more electron to bring about an electrical equilibrium.

There are many other elements like fluorine. In fact, every element aside from the inert gases, helium, neon, krypton, xenon and argon does not have its outer shell satisfied or occupied, and it is always trying to make pairs or octets to complete its arrangement and to bring about an electrical equilibrium. **This is the basis of all chemical combination and activity.**

What arrangement do the electrons make in atoms with more than ten? The electrons over ten form another octet or shell over the first one. If there are enough electrons, the third and even the fourth octet or shell is formed. The outside shell or octet, of all the atoms, aside from those of the inert gases, is incomplete. Therefore, all of the elements are chem-

ically active aside from the inert gases. We must look upon chemical action as merely an interchange of electrons.

CHEMICAL FORMULAS

Having covered the cause of chemical reaction, we are now in a position to understand chemical formula and expression. We now know that water is expressed chemically H_2O . This signifies that there are two atoms of hydrogen and one of oxygen in the water molecule. The reaction between oxygen and hydrogen can be expressed in this way:

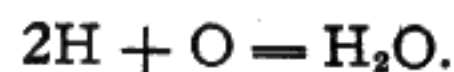

This means that hydrogen plus oxygen equals water. It must be understood here that all chemical elements do not react when brought together. Some elements are very inert or chemically inactive. In other words, they have very stable atoms in perfect electrical equilibrium. Thus, the gas helium is extremely inert. In fact, it is not possible to make it combine with any known element. We must also remember that a chemical reaction can take place between compounds as well as between elements. When two elements or

compounds react with one another, it is said to be due to "chemical affinity." However, we now know that this chemical affinity is really electrical in nature.

Let us see what would happen if we were to drop a small piece of the element sodium (Na) into water (H_2O). If this is done, a very energetic reaction to hydrochloric acid (HCl). The result can be represented by the formula:



If we study this carefully we can account for all of the elements that entered into the reaction. We can

also see that we have ²⁰made or caused to be made a new compound. The NaOH is called sodium hydroxide (the word hydroxide is produced by a combination of hydrogen and oxygen). The resulting molecule which makes up the mass of the sodium hydroxide is composed of one atom of sodium, one of hydrogen and one of oxygen. We must remember, however, that we had two atoms of hydrogen when we started out. What became of the second one? The + H on the end of the chemical expression signifies that the second atom of hydrogen escaped in a free condition. If we were to place a test tube over the sodium immediately it was placed in the water, we could collect the hydrogen as it left the surface of the water.

The amateur chemist must learn that when two chemical compounds are placed together and a reaction takes place, each one of the elements that entered into the reaction must be accounted for. Let us place two more substances together and see what happens. This time we will add a small piece of iron (Fe) to hydrochloric acid (HCl). The result can be represented in this way:



The result of this chemical reaction is iron chloride and free hydrogen. We can see from this that the iron must have had a greater chemical affinity for the gas, chlorine, than the hydrogen had. Hence, the metal and the hydrogen merely changed places.

SPEED OF CHEMICAL REACTIONS

At this point it will be well to mention that all chemical reactions do not take place at the same rate of speed. When the sodium was placed in water,

²¹the reaction took place very rapidly. In fact, if the piece of sodium had been large enough, the reaction would have been so violent and the heat generated so great, that the hydrogen escaping would have been ignited and an explosion would have resulted. All reactions, however, are not so violent as this one.

Some substances take weeks and even months to undergo a tangible reaction. On the other hand many reactions take place in a remarkably short space of time. The explosion of dynamite takes place in 1/24,000th of a second.

All chemical reactions are not so simple as those illustrated above. The more elements present in any chemical reaction the more complex it will be. The following reaction is more complicated than those mentioned hitherto:



This is the action that results when sodium hydroxide is placed in contact with sulphuric acid. The result is water and sodium sulphate.

PHYSICAL AND CHEMICAL CHANGES

When water is frozen, is the change a chemical or a physical one? This is a question that must be decided before we go farther. The change of liquid water into ice is entirely physical. That is, no fundamental change has taken place in the molecular arrangement of the water; the change is not a permanent one that gives the water a different chemical nature. A chemical change always produces an entirely new substance. For instance, when coal burns, a white ash is left and there is nothing left that resembles the original material. This is a chemical change.

Chemical action is always accompanied either by the liberation or absorption of heat. When aluminum burns in oxygen, forming aluminum oxide, a terrific heat is produced by the reaction. In other cases, heat is absorbed by a reaction. However, in most cases heat is liberated. The more rapid a chemical reaction takes place, the higher the temperature produced will be. In the oxidation of aluminum, as carried out in the Thermit process of welding, a temperature of nearly 5000 degrees Fahr. is produced. In slow chemical reactions that extend over a great length of time, heat is liberated but not perceptibly. In some cases, there is such a slight rise in temperature that it is almost immeasurable. In every case, a specific amount of heat is liberated, and this depends entirely upon the amount of the substances or elements that enter into the reaction.

THE LAW OF DEFINITE PROPORTIONS

When two chemical elements react to form a compound, they always do so in definite proportions. For instance, when copper burns in oxygen, forming copper oxide, there is always the same proportion by weight of oxygen and copper. The substance, if analyzed, will be found to contain 79.96 per cent copper

and the remainder oxygen. If there is any excess of either one of the two elements present during the reaction, it will remain unchanged. This law holds true throughout the entire science of chemistry, and it is called the Law of Definite Proportions. It must be stated as follows: A pure compound always contains the same elements in constant ratio by weight.

23

DIFFERENT KINDS OF CHEMICAL REACTION

We are now ready to learn of the three different kinds of chemical action. If the red oxide of mercury is heated in a test tube over a Bunsen flame, oxygen will be given off and pure metallic mercury will be left in the tube. The application of heat brings about a separation of the elements oxygen and mercury. In other words a decomposition has taken place and this chemical action is therefore called one of decomposition. We will define a chemical action of decomposition, then, as one in which a compound is divided or broken up into its constituents.

If iron filings are placed in a test tube with powdered sulphur and heated, the mass will gradually change to a black appearing substance called iron sulphide. This chemical action is said to be one of synthesis or combination—two elements combined to form a new compound.

If a little sodium hydroxide (NaOH) is placed in a test tube containing a solution of copper sulphate (CuSO₄) a white precipitate will fall to the bottom of the tube. After this action has taken place, there is present in the tube copper hydroxide and sodium sulphate. The sodium changed place with the copper and the copper changed place with the sodium. Such a chemical action is said to be one of exchange or substitution.

CLASSIFICATION OF CHEMICAL COMPOUNDS

When iron reacts with the gas chlorine, a compound known as iron chloride is produced. If copper was to react with the gas in place of iron, we would have

24

copper chloride. In fact, most of the metals will react with chlorine to form what is known as a "chloride" of the particular metal which enters into the reaction. If the metals react with sulphur, sulphates or sulphides result. If they react with water, hydroxides result. If sodium reacts with the gas nitrogen, a compound known as sodium nitrate is the product of the reaction. Thus, we also have a number of compounds known as nitrates and nitrides. When the word nitrate, sulphate, or chloride is used,

we know, then, that the compound mentioned will contain either nitrogen, sulphur or chlorine. Many of the metals combine with the gas, carbon dioxide. The resulting compound is called a carbonate. Thus, we have potassium carbonate, sodium carbonate, calcium carbonate, etc. When other elements combine with phosphorus, phosphates are produced. We have sodium phosphate, calcium phosphate and potassium phosphate. The reader, however, should not confuse himself by thinking that all the elements combine with phosphorus, nitrogen or chlorine to form phosphates, nitrates and chlorides.

THE LAW OF COMBINING WEIGHTS

The law of combining weights is a very important part of chemistry. The best we can do in the limited space we have at our disposal is to give the outstanding features of it. Upon referring to the list of elements which appear on pages 8 and 9 we will find the atomic or combining weight written after each element. Thus, after nitrogen we find 14, after oxygen 16, etc. This number, we must remember, represents the weight of each element. By it we are able to ascertain, in a comparative way, the weights of the different elements. We know that hydrogen, which

25

is 1.008, must be much lighter than lead, which is given as 207.10. Now, if lead combines with any other element, the weight of the resulting compound will be 207.10 plus the combining or atomic weight of the element which entered into the reaction with the lead. When oxygen and hydrogen combine to form water, we know the formula to be $2H + O = H_2O$. The subscript 2 means that two combining weights (or we may say atoms) of hydrogen unite with one combining weight of oxygen. We know that the combining weight of hydrogen is 1.008 and that of oxygen 16. Knowing this, then, we can easily figure the molecular weight of water. We say molecular weight because it is the sum of the weights of the atoms contained in the molecule. It is figured in this way: $1.008 \times 2 = 2.016 + 16 = 18.016$ molecular weight of water. When hydrogen combines with the gas chlorine to form hydrogen chloride, the molecular weight of the resulting compound will be 35.46 (chlorine) $+ 1.008 = 36.468$ molecular weight of hydrogen chloride. Hydrogen chloride is expressed chemically in this way, HCl . Here we see that only one combining weight of hydrogen enters into combination with one combining weight of chlorine.

SOLUTIONS

At this point, we will consider solution. When ordinary table salt is dissolved in water, we say we

have a solution. Solutions play a very important part in chemistry. When a substance is capable of passing into solution, we say it is "soluble." Different substances have different degrees of solubility. Some are so backward in this respect that we call them insoluble. Others are extremely soluble. Not only are solids capable of forming solutions, but some gases also. Hydrogen chloride (which is really called hydrochloric acid gas) is very soluble in water and when in solution it is called hydrochloric acid.

Temperature plays an important part in the phenomena of solutions. In general it can be said that the higher the temperature of water is the greater its dissolving powers will be. The illustration in Fig.

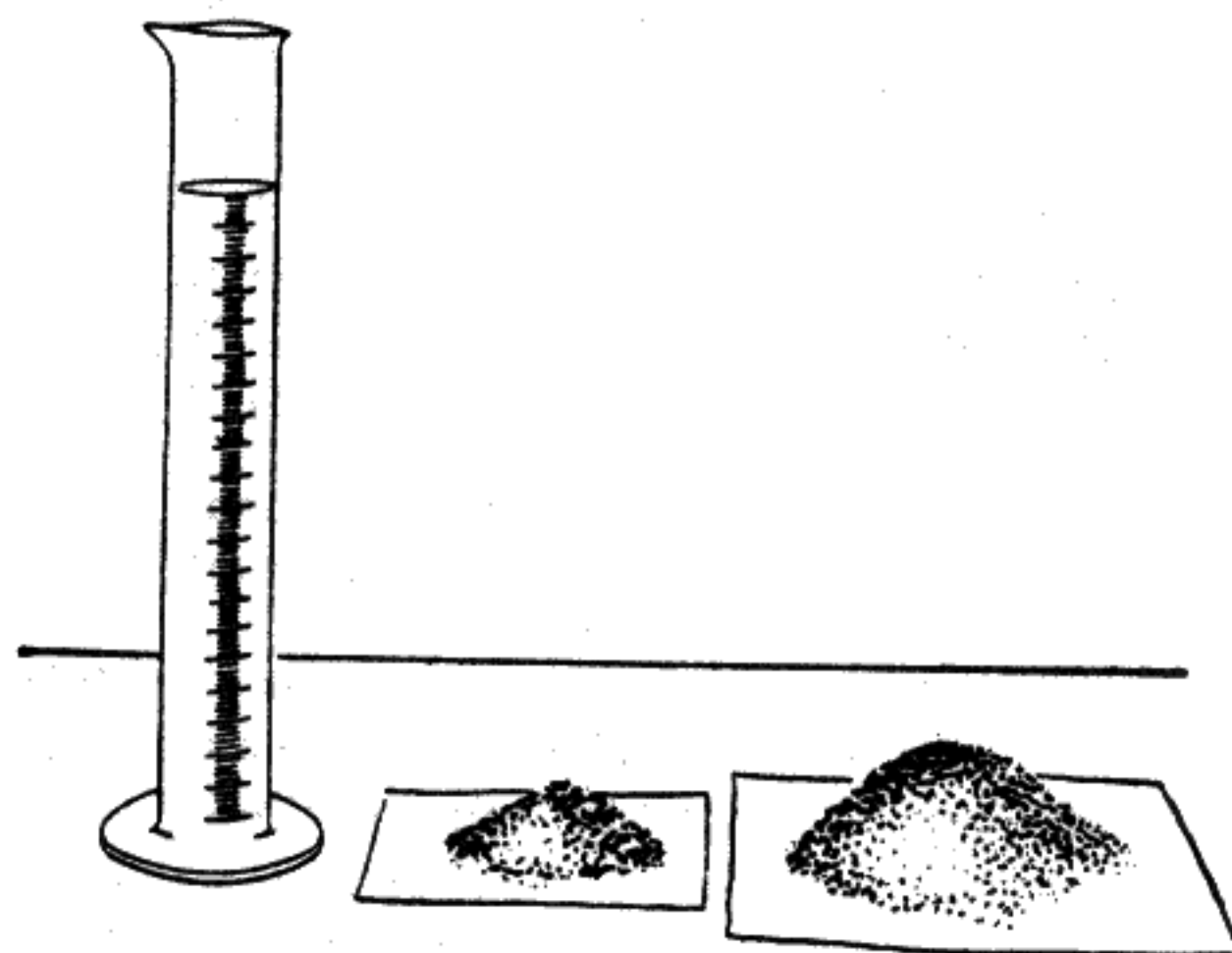

Fig. 5.—The Illustration Shows the Difference in the Amount of Sodium Nitrate Dissolved in 100 c.c. of Hot and Cold Water.

5 shows the difference in the amount of sodium nitrate dissolved in a given volume of hot and cold water. The higher the temperature of the water the greater the amount of sodium nitrate it will be capable of taking into solution. We may say that for any given temperature a given volume of water will be capable of dissolving a specific amount of any soluble substance.

What would happen if we were to dissolve a salt in hot water and then permit the water to cool? Upon cooling, a certain portion of the salt would re-crystallize and precipitate to the bottom of the vessel.

ACIDS AND BASES

We now come to a consideration of acids and bases. A substance is either acid, base or neutral. Some substances are strongly base, others only slightly so.

Acids have many properties in common, by means of which they can be identified. They all taste sour, redden litmus paper and contain hydrogen as

one of their essential constituents. Of course, this does not mean that all compounds containing hydrogen are acid. However, there is no acid that does not contain hydrogen. Another general characteristic of acids is that they liberate hydrogen when they come in contact with magnesium, or zinc. In fact, most of the acids liberate hydrogen upon contact with most any metal. The following shows the reaction caused by bringing zinc in contact with hydrochloric acid:



The following is a short list of the more common acids:

Hydrochloric acid.....	HCl
Hydrobromic acid.....	HBr
Hydriodic acid.....	HI
Nitric acid.....	HNO ₃
Acetic acid.....	HC ₂ H ₃ O ₂
Sulphuric acid.....	H ₂ SO ₄
Phosphoric acid.....	H ₃ PO ₄
Oxalic acid.....	H ₂ C ₂ O ₄

Acids manifest their characteristic properties only when dissolved in water or a few other solvents. We

28

is done, we will find that the resulting solution will neither turn blue litmus paper red nor red litmus paper blue. It has neither an alkaline nor sour taste nor a soapy feeling. It will not evolve hydrogen when it comes in contact with either magnesium or zinc. In fact, the solution exhibits none of the properties common to acids or bases. If the solution is tasted it will be found to have a distinct salty taste. An outline of the reaction which takes place will account for this:



The resulting product of the reaction is sodium chloride (NaCl), or common table salt. The salt can be obtained by completely evaporating the water by the application of heat. The salt will be left in the receptacle in its usual crystalline form.

All the bases and acids neutralize each other when they come in contact. Of course, the resulting reaction is not the same as the one outlined above. When potassium hydroxide (KOH) and nitric acid (HNO₃) are brought together the following reaction takes place:



what takes place when an acid is brought in contact with ethyl alcohol:

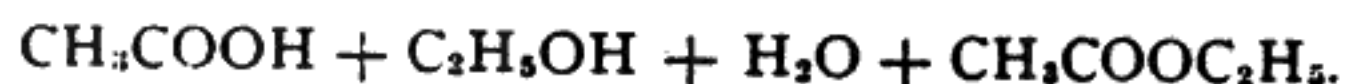

It will be very easy to distinguish this reaction from those that we have been considering throughout this book. The study of organic chemistry is quite out of the scope of this book, which is prepared to give the beginner an insight into organic chemistry.

ELECTROCHEMISTRY

Many years ago, early chemical investigators discovered a remarkable connection or relationship between chemistry and electricity. With the outline of the electron theory fresh in our minds this statement should not be amazing. The science which deals with electricity and chemistry has been called electrochemistry from a combination of the two words. It will be within the province of this book to briefly consider this particular phase of chemistry, which is very important.

31

We now come to a consideration of an ion, and having in mind the meaning of an atom, we need only add an electrical charge to the atom and we have an ion. But, in doing this, we must keep in mind that there are two different kinds of electrical charges—negative and positive. That like charges of electricity repel one another and unlike charges attract, is also an important factor. We mean by this that two negative charges would repel each other, but a negative and a positive charge would attract each other. If these charges were distributed upon two bodies, the bodies would have a very noticeable tendency to attract or repel each other, depending upon the nature of the charges that were on their surfaces. We will conclude this explanation of an ion by assuming that it is an ordinary atom of matter carrying with it either a positive or negative electrical charge. If the charge is negative, we say it is a negative ion, and if it is positive, we say it is a positive ion.

The average reader will be surprised to learn that chemically pure water is a non-conductor of the electric current—that is, it conducts to such a very small extent that it is called a non-conductor. The fact may be proved by a very simple experiment, providing chemically pure water is at hand. The water is placed in a vessel and made to form a part of an electric circuit in which a current is flowing. If a sensitive indicating instrument is placed in the circuit, we find that the water will not permit a current to pass through it. Let us drop a pinch of table salt or sodium chloride into the water and see what happens. It will do us no good to look into the water,

as the process that is taking place there is far beyond our sight, but let us look at the indicating instrument. Upon the addition of the sodium chloride to the water, we notice that the instrument gives a marked indica-

32

tion, proving beyond all possible doubt that a current is passing through the water. Something very wonderful has certainly happened to the water. It behooves us to learn just what has taken place.

The chemical philosophy of Svante Arrhenius, whose hypothesis of electrolysis we set out to learn, tells us that the molecule of the table salt or sodium chloride that we dropped into the water has broken up into ions. We mean by this that the atom of sodium and the atom of chlorine in the molecule of sodium chloride have dissociated. Not only this, but that they have suddenly acquired an electrical charge and have become ions. The theory tells us that the sodium ion is positively charged and that the chlorine ion is negatively charged. After being told that the electrodes that lead the current into the water from the battery are electrically charged, we immediately decide that something very interesting is about to take place. The electrode that leads the current into the water is called the cathode and is negatively charged. Remembering that we have tiny charged atoms in the water, and in accordance with the preceding explanation concerning the attraction of differently charged bodies, we naturally expect the anode and the cathode to attract the ions in the water. This is just what happens. The sodium ions being positively charged, are attracted by the cathode or negative electrode, and the chlorine ions, being negatively charged, are attracted by the anode or positive electrode. Thus we can picture an ionic migration taking place within the water, the tiny particles with the positive charge rushing one way to the cathode and the negatively charged particles rushing the other way to the anode. We have forgotten something. In assuming that the water contains free atoms of sodium, we have forgotten that these same atoms are very sensitive to

33

water and that a great chemical affinity exists between water and sodium. Indeed, if metallic sodium in sufficient quantity is thrown into water, it will react with explosive violence. Why do our atoms or ions of sodium not react with the water in the vessel? Is it because of their electric charge? Arrhenius tells us that it is. He claimed that the electric charge carried by the sodium ion protects it from the water and prevents a chemical reaction from taking place. Keeping this fact in mind, we will follow one of these little ions of sodium through the water until it suddenly

bumps into the negatively charged cathode. If our eyes were powerful enough to see, we would find that the ion of sodium immediately reacts with the water upon reaching the cathode. Is this a hitch in our theory or is it in accordance with what should take place? It is just what should take place. Upon reaching the negatively charged cathode, the tiny positive charge carried by the sodium ion is neutralized and the ion is therefore restored to a normal atom of metallic sodium. Being robbed of its positive charge, it is no longer protected from the water and immediately reacts with it to form a substance called sodium hydroxide. The same thing happens at the anode. The negatively charged ion of chlorine is neutralized upon reaching the anode, and having no chemical affinity for the water, it rushes to the surface and escapes into the atmosphere.

Having proved that sodium chloride will change water from a non-conductor, we will see if other substances will cause the same result. We will start with cane sugar. No matter how much sugar is dissolved in the chemically pure water the conductivity will not be increased in the least, as will be noted by watching the indicating instrument. We decide, then, that all substances that dissolve in water do

34

not act like salt. In the words of our theory, they do not ionize. A substance that ionizes or causes water to become a conductor of the electric current when it is dissolved in it is termed an electrolyte. A substance that does not affect water in this way, such as sugar, is called a non-electrolyte. There are many different substances that are electrolytes and many that are non-electrolytes. The following table contains names of a few of the most prominent ones of each class:

Non-electrolytes	Electrolytes
Cane sugar	Sodium nitrate
Methyl alcohol	Sodium chloride
Ethyl alcohol	Sulphuric acid
Benzene	Nitric acid
Ether	Hydrochloric acid
Chloroform	Potassium hydroxide
Acetone	Sodium hydroxide
Glycerine	Acetic acid
	Oxalic acid
	Silver nitrate
	Ammonium hydroxide
	Potassium sulphate
	Potassium nitrate

We could add many more substances to this list before it would be complete. In fact, every substance is either an electrolyte or non-electrolyte.

While we have only considered the electrolytic decomposition of sodium chloride in the foregoing paragraphs, we must not confuse ourselves by thinking that this is the only substance that will act in this manner. The electrolysis of sodium chloride presented a simple case and was merely taken as an example. It will be understood that the products of

35

electrolysis will depend entirely upon the chemical composition of the electrolyte and nothing else. Chemically, sodium chloride is a very simple compound, being composed of the metal sodium and the gas chlorine. All electrolytes do not have this very simple formula, however, and we are interested to know just how a more complex compound of matter would act, or, to be more explicit, just how it would ionize when dissolved. Glancing at our list of electrolytes, we find sulphuric acid among those named, and we will see just how this common acid will perform when dissolved in water. It is represented by the chemical symbol H_2SO_4 , but this need not confuse us, as it merely indicates that it is composed of hydrogen (H), sulphur (S) and oxygen (O). Will each atom of the respective elements that form sulphuric acid act as ions or will they group themselves? The theory of Arrhenius tells us they should group themselves, the positive ions in one group and the negative ions in another group. We find this to be true with sulphuric acid, as the hydrogen atoms forms the positive ions while the atoms of sulphur and oxygen remain together and form compound negative ions. Before placing the sulphuric acid in water we knew the atom of hydrogen would form the positive ion and the combined atoms of sulphur and oxygen the negative ion, but just what foretold this action? The Arrhenius theory contains a general rule that tells us how the atoms of the different elements will act when they are ionized—that is, whether they will be positive or negative. The rule is a very simple one and can be easily remembered. It states that the atoms of all the metals and hydrogen will form positive ions when placed in solution. If this is the case, the atoms of all the elements outside of these will form negative ions. We will see, then, that sulphuric acid substan-

36

tiated this rule. The hydrogen atom or ion was positive and the atoms or ions of the sulphur and oxygen were negative.

A very beautiful experiment showing this profound positive nature of the metals can be performed. A dilute solution of sulphuric acid is placed in a small tube equipped with two electrodes. A tiny globule of mercury is then placed in the tube

and a direct current is sent through the solution. The little globule of mercury will travel rapidly to the negative pole, thereby proving that it is of a positive nature. In this way it acts just as a ion of mercury would in solution.

Having in mind the general characteristics of electrolytes, we will place a problem before ourselves and see if we can solve it. Again referring to our list of electrolytes, we find sodium hydroxide. This is recognized chemically by the formula NaOH . The Na stands for sodium and the OH for oxygen and hydrogen respectively. Remembering our rule that all the metals and hydrogen are electro-positive, we see that we have two positive elements in this compound: sodium and hydrogen. We would naturally expect the atoms of sodium and hydrogen to unite and form a complex positive ion like the atoms of oxygen and sulphur united to form a complex negative ion when sulphuric acid was electrolyzed. We are indeed surprised to learn that this does not hold true with sodium and hydrogen, and yet it does not necessarily disprove our theory. This apparent hitch is overcome by assuming that the negative charge on the oxygen ion is stronger than the positive charge on the hydrogen ion and it therefore insists upon holding the hydrogen ion in close relationship to it. The sodium hydroxide then ionizes according to the equation $\text{NaOH} = \text{Na} + \text{OH}^-$ where the Na represents sodium

37

and the O and H oxygen and hydrogen respectively. The ion OH^- is called the hydroxyl ion.

EXPERIMENTS IN ELECTROCHEMISTRY

We are now prepared, in the light of the theory

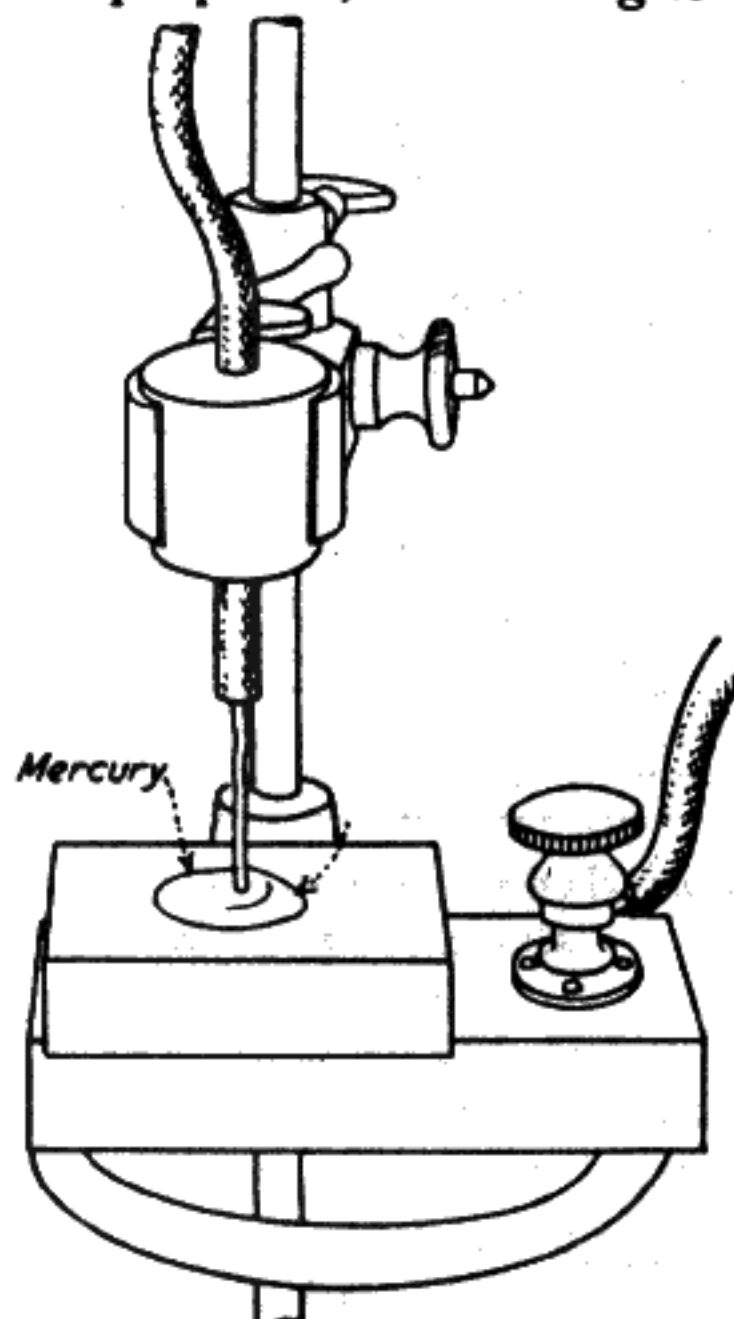

Fig. 6.—A Reproduction of Sir Humphry Davy's Experiment of Producing Metallic Sodium.

set forth in the preceding paragraphs, to make a few experiments in electrochemistry, for the subject of electrolysis is nothing but a study of electrochemistry. We will start our experiments with a reproduction of Sir Humphry Davy's experiment, in which he isolated the element sodium from one of its compounds. The arrangement of the apparatus for the experiment is

38

shown in Fig. 6. It is, of course, understood that this experiment must be carried out with direct current. The space between the block of sodium hydroxide dissolves to form the electrolyte. The mercury merely acts as an electrode. As fast as the metallic sodium is set free at the negative electrode or mercury it forms a sodium-mercury amalgam. When the sodium becomes amalgamated with the

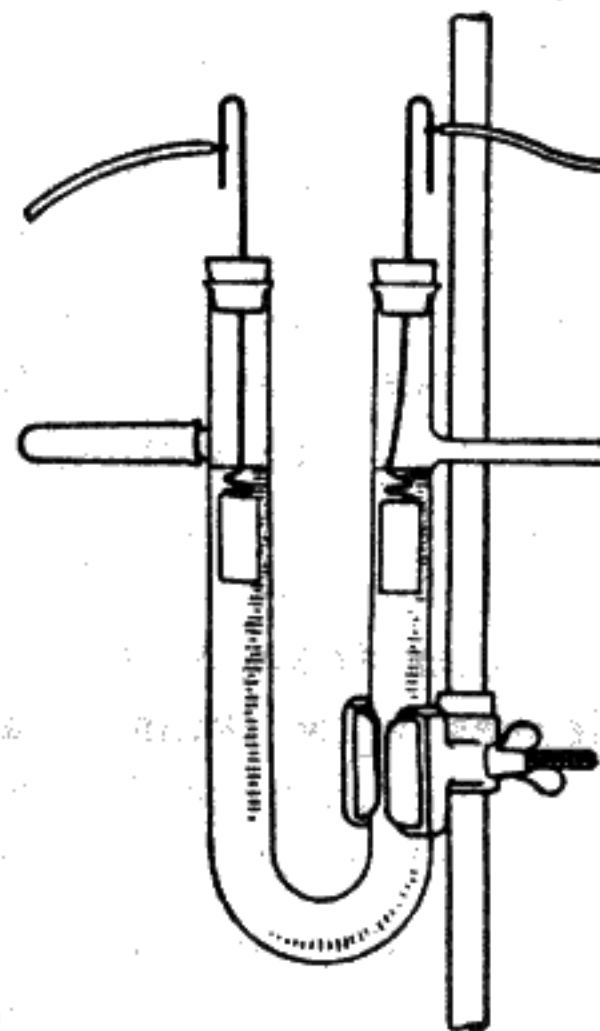

Fig. 7.—Apparatus for the Electrolysis of Zinc Chloride to Obtain Metallic Zinc.

mercury it is protected from the water in the electrolyte, as we must not forget that sodium is chemically very sensitive to water. After the current has passed for a few minutes, we find that the mercury becomes hard and stiff owing to the sodium amalgamating with it. It will be necessary to keep the surface between the mercury and the sodium hydroxide well moistened during the experiment. The sodium may be separated from the mercury by a process of distillation. We

39

can obtain potassium from its hydroxide in the same manner.

In our next experiment we will produce more metallic zinc by a process of electrolysis. The apparatus used is shown in Fig. 7. It consists merely of a U-tube with two electrodes and a solution of zinc chloride. If the current is permitted to pass through this solution for a short time, we notice a beautiful formation of metallic zinc at the negative electrode, while the anode product will be the gas chlorine.

40
PART II

THE CHEMICAL LABORATORY

Method of Obtaining Heat—Bottles—A Chemical Balance—Test Tube Racks—A Ring Stand—A Hydrogen Sulphide Generator—Necessary Apparatus—Test Tubes—Evaporating Dishes—Fire Clay Crucibles—Filter Paper—Graduated Cylinder—Chemical Thermometers—Pipette—Red and Blue Litmus Paper—Beakers—Pinch Cocks—Thistle Tubes—Flasks—Clamps—Chemicals for the Laboratory.

The chemical laboratory should be located in a light, airy place and should occupy a space at least 15 ft. x 15 ft. Running water should also be available, although this is not absolutely essential. Illuminating gas should also be available for heating purposes, but there are substitutes for this in the event gas is unobtainable.

Benches and shelves should be placed on at least two sides of the room, so that plenty of space will be provided to work with and to store apparatus and chemicals. The shelves should be placed back of the benches, as shown in Fig. 8. Both the shelves and the benches can be made from $\frac{3}{4}$ -in. yellow pine. The bench legs can be formed by 2 x 4's. The benches do not need to be wider than 3 ft. and the shelves 8 inches. This leaves a working space of 2 feet, 4 inches on the bench. A tier of four shelves is generally high enough. The first two shelves can have a space of one foot between them for large bottles, and the next two a space of 8 inches for small bottles and apparatus.

Part of one of the benches should be covered with some acid-resisting material, such as slate or marble. This space can then be used when working with corrosive acids to prevent the boards in the workbench

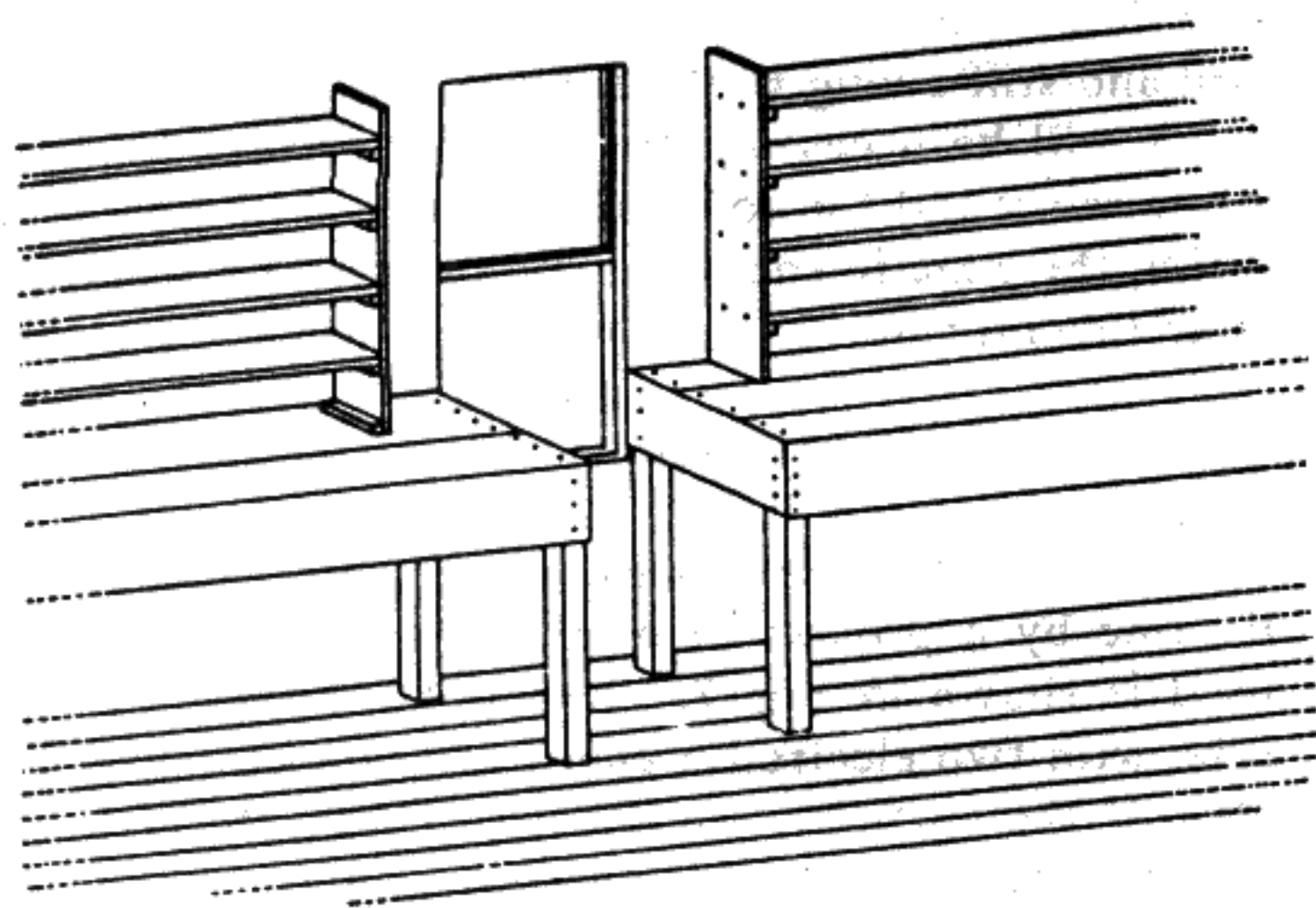

Fig. 8.—How the Laboratory Shelves and Benches Can be Constructed.

from becoming unsightly. If the amateur chemist desires he can paint all of the bench surface over with an acid-proof preparation. The author is indebted to Mr. Nomas Tallman, a contributor to *Everyday Engineering Magazine*, for the following receipt:

“A fire and chemical proof paint, which leaves a nice looking finish is made by boiling 790 parts of copper sulphate, 790 parts of potassium chromate and 1000 parts water in the same container.

When the solution is boiling, apply one coat to the article to be finished. Allow the solution to dry one day, then boil the solution again and apply the second coat allowing this to dry two days. Heat 100 parts of aniline oil, 100 parts water in another container to a

high boiling point and apply one coat to the article, and let dry for one day.

Make a new solution of aniline oil, hydrochloric acid and water, like the previous one and apply in the

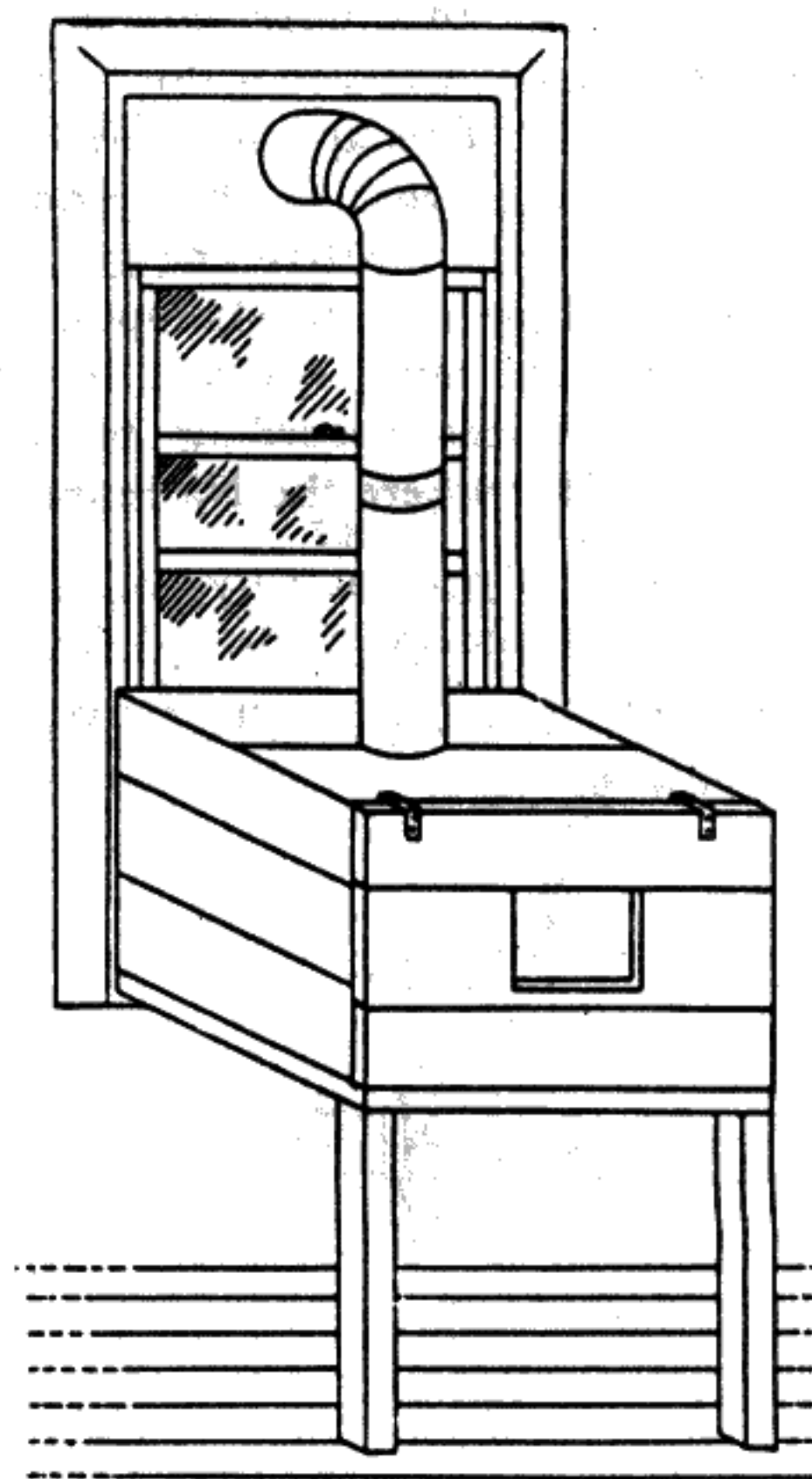

Fig. 9.—A Simple Hood to Carry Away the Gases Caused by Chemical Reactions.

same manner. Let the article dry two days. Wash the article in soapy water and let it dry thoroughly, then rub it with linseed oil and it will leave a highly polished dark gray surface.

The parts used are taken by weight, and the solutions may be applied with a paint brush. Care should

be taken not to mix the two solutions before applying, and a new brush should be used for the second solution. The brushes should be washed after each coating."

Provision must be made to dispose of the obnoxious smelling and dangerous gaseous products given off during certain chemical reactions. In large laboratories these reactions generally take place under what is known as a hood which leads the gases to the outer atmosphere. An improvised hood for home use can be very easily made. Such a hood is shown in Fig. 9. The box should be large enough to accommodate different combinations of the chemical apparatus found in the laboratory. A box three feet square should prove to be a very suitable size. This can be made of galvanized iron or wood. In fact, wood is preferable. A hole should be cut in the top of the box to accommodate a piece of stove pipe. The pipe should lead to the outer atmosphere. A good method of doing this is shown in the figure. A piece of wood is cut just large enough to fit in the window. The pipe passes through this. A door of some kind should be arranged on the hood so that trouble will not be had in setting apparatus inside the box. The door should also fit well to prevent gases from escaping. The door should also have a glass window in order to see how any reaction is progressing. A small electric light placed inside the hood will make this possible.

METHOD OF OBTAINING HEAT

We now come to a consideration of the heat. If gas is available, the heating problem is a simple one. Two Bunsen burners should be obtained. Bunsen

44

burners can be purchased from any chemical supply house and they are so inexpensive that it would really not pay one to bother constructing them. Several feet of rubber hose should be bought with the burners so that they can be moved to any part of the bench.

In the event illuminating gas is not available the next best substitute seems to be alcohol. A good alcohol burner is shown in Fig. 10. A large wide



Fig. 10.—A Simple Alcohol Burner for the Laboratory.

mouthered bottle, a rubber cork, a brass tube and a wick are all that are needed for its construction. The parts are assembled as shown. The ordinary little alcohol lamps, although suitable for many purposes about the laboratory, will not be found to produce sufficient heat for all purposes. The temperature they produce is quite high enough for ordinary purposes, but the volume of heat is insufficient.

BOTTLES

A word about bottles. While it contributes much to the general appearance of the laboratory to have bottles of uniform size and shape, such bottles are

45

very expensive. Often times it is possible to accumulate many bottles of the same size and shape in which some patent medicine or other substance is sold. A number of small bottles should also be collected in which the more costly chemicals are kept. Each bottle should be labeled properly with both the formula and the name of the substance in it. This is an example:



Sulphuric Acid.

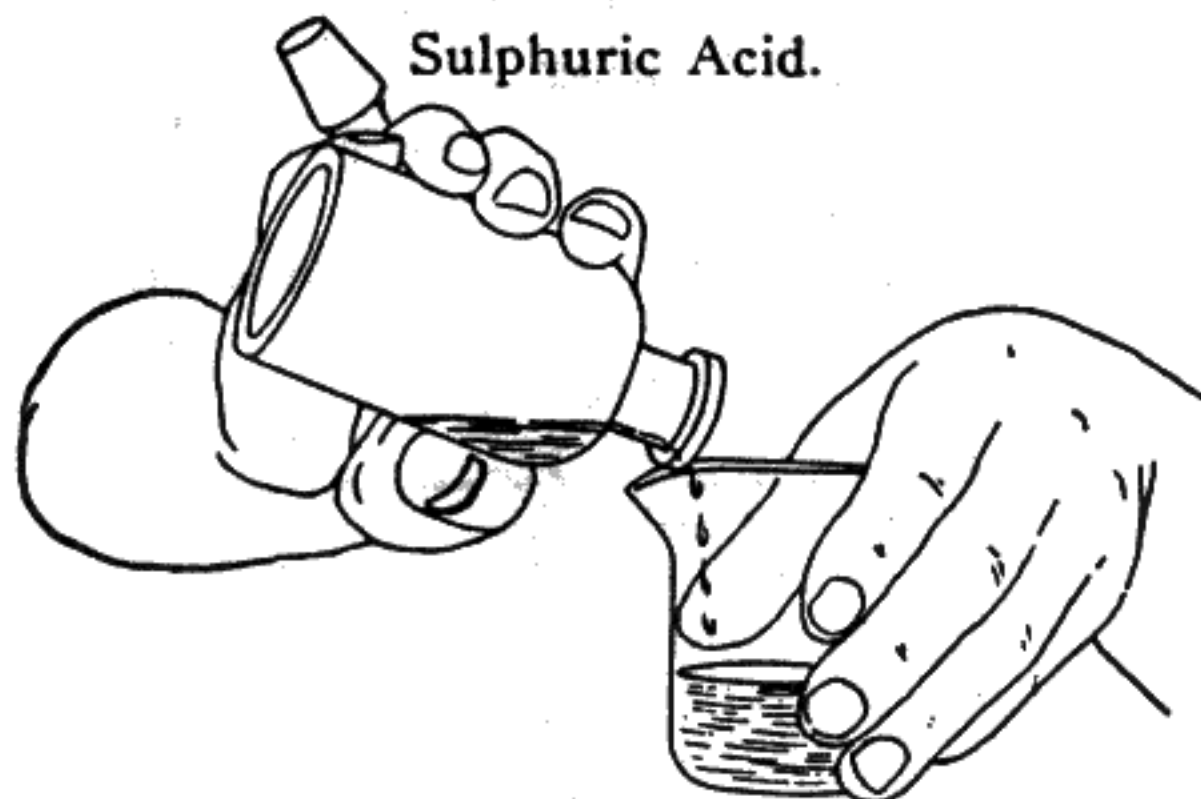

Fig. 11.—When Pouring a Chemical from a Bottle, the Stopper Should be Held Between the Fingers as Shown.

Great care should be taken that no mistakes are made in putting the wrong chemical in any bottle. This would probably result disastrously in some cases.

It may be well to mention at this point how to pour a liquid from a bottle. First, the liquid should be poured from the side of the bottle opposite the label. If a drop of the liquid runs down the side of the bottle, it will not destroy the label. Fig. 11 shows the proper method of pouring liquid from a bottle.

46

A CHEMICAL BALANCE

A good chemical balance on which different amounts of chemicals can be determined accurately is badly needed. Mr. Dana S. Greenlaw, a contributor to *Everyday Engineering Magazine*, describes the construction of a home-made balance which the author

believes is hard to improve upon. Mr. Greenlaw's description follows:

"For serious chemical work the experimenter should have a small balance in his laboratory. Such a balance, however, is very costly and, therefore, many experimenters find it necessary to work without one.

The balance described in this article is very inexpensive and easily constructed. The materials necessary are not uncommon and all of the parts can be made with little labor.

Fig. 12 illustrates the completed balance. The handle (Q) raises the beam lift (H) and thereby not only removes the weight from the bearing, but also prevents the beam from swinging. The lever (O) permits the stop (K) to drop and allows the pans to swing. The bearings are made from an old hack saw blade.

The beam of the scale will be considered first. This is made of either brass or aluminum and is $\frac{1}{8}$ inch thick, $\frac{1}{2}$ inch wide and 10 inches long. In the center of the beam a $\frac{1}{8}$ inch slot is sawed. A $\frac{1}{2}$ inch hack saw blade is then ground to a knife edge. A piece $1\frac{1}{2}$ inches long is soldered into the slot. (See A.) This forms the main bearing of the beam. Exactly $\frac{1}{4}$ inch from each end of the beam a small V-shaped groove (D) is made.

The base of the balance is cut from a piece of $\frac{1}{2}$

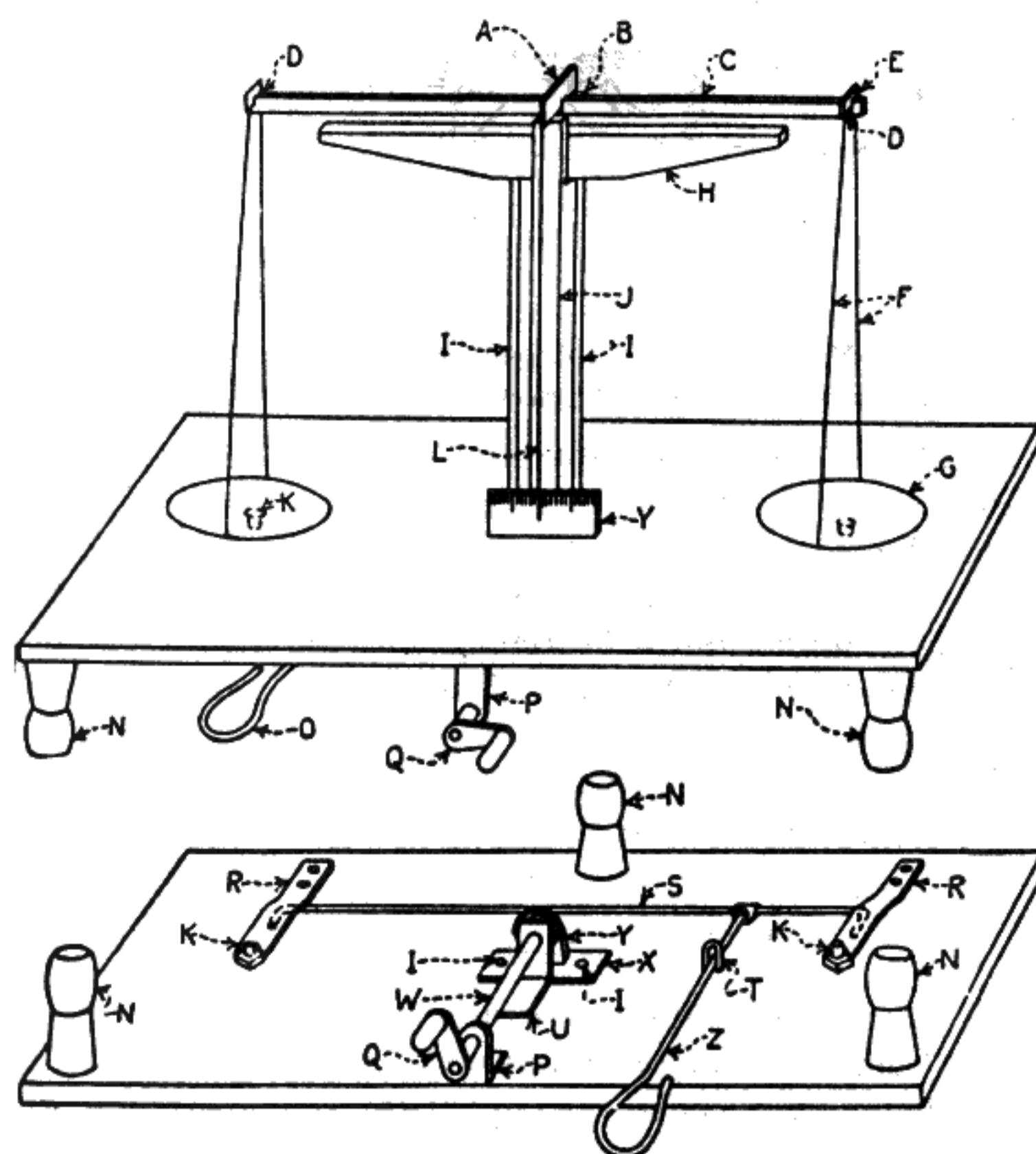

Fig. 12.—Constructional Details of a Small Chemical Balance.

inch hard wood. It is $7\frac{1}{2}$ inches wide by 13 inches long. In the center of the base the upright (J) is

47

placed. This upright is $\frac{1}{2}$ inch thick, 1 inch wide and 8 inches long. At the top of the upright or standard the slot for the beam lift (H) to slide in is made. This slot is $\frac{3}{8}$ inch wide and $1\frac{1}{4}$ inches long. The bearings (BB) are screws, the slots of which are filed out to a V shape.

The beam lift (H) is made of $\frac{3}{8}$ inch stock. It is

48

one inch wide and $6\frac{1}{2}$ inches long. $2\frac{1}{2}$ inches from each end it begins to taper. At the end it is $\frac{3}{8}$ inches wide. The brass rods (II) pass through the base and are soldered to the brass strip (X). The cam (Y) causes these rods to be either raised or lowered. This cam is belted or soldered to the rod (W) which is attached to the handle (Q). The rod (W) is held in place by the brass strips (UP) which are screwed to the base.

The pieces (KK) prevent the pans from swinging. The nuts adjust them so that they will come to the proper height. These bolts are $\frac{3}{16}$ inch in diameter and $1\frac{1}{2}$ inches long. The springs (RR) hold these bolts in position. These springs should be made very weak. The handle (Z) causes the rod (S) to turn. The hooks on this rod lift the spring and thus allows the bolts to drop. The writer used a rib from an umbrella to make the rod and handle. The guide (Y) holds the handle in place. The legs of the balance are turned to shape on a lathe, although square ones would serve the purpose just as well. The pointer (L) is a fine knitting needle. Scale (Y) shows when the beam is in balance.

The pans are of aluminum or nickled brass. They are attached to the beam by the two knitting needles (FF). These needles are soldered to the bearing (E) which is made of a hack-saw blade. These bearings swing in the groove previously produced in the beam.

The more carefully this balance is made the more accurate and sensitive it will be and the smaller the quantity it will register. The base may be made large enough to enclose the balance in a glass case. If such a case is used the front should have a door which opens. If a case is used a small beaker of sulphuric acid or calcium chloride should be kept in it to prevent moisture from attacking the balance."

49

TEST TUBE RACKS

Several small test tube racks should be made for the laboratory. These are very simple to construct and no description should be necessary as the drawing (Fig. 13) gives all the necessary details.

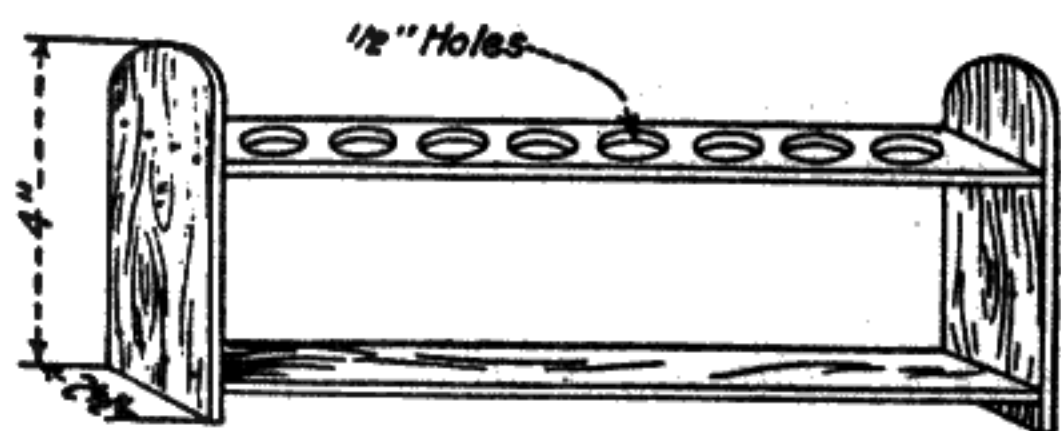

Fig. 13.—Dimensions of a Small Test Tube Holder.

A RING STAND

A ring stand can be very easily made. The complete details are given in Fig. 14. The base of the

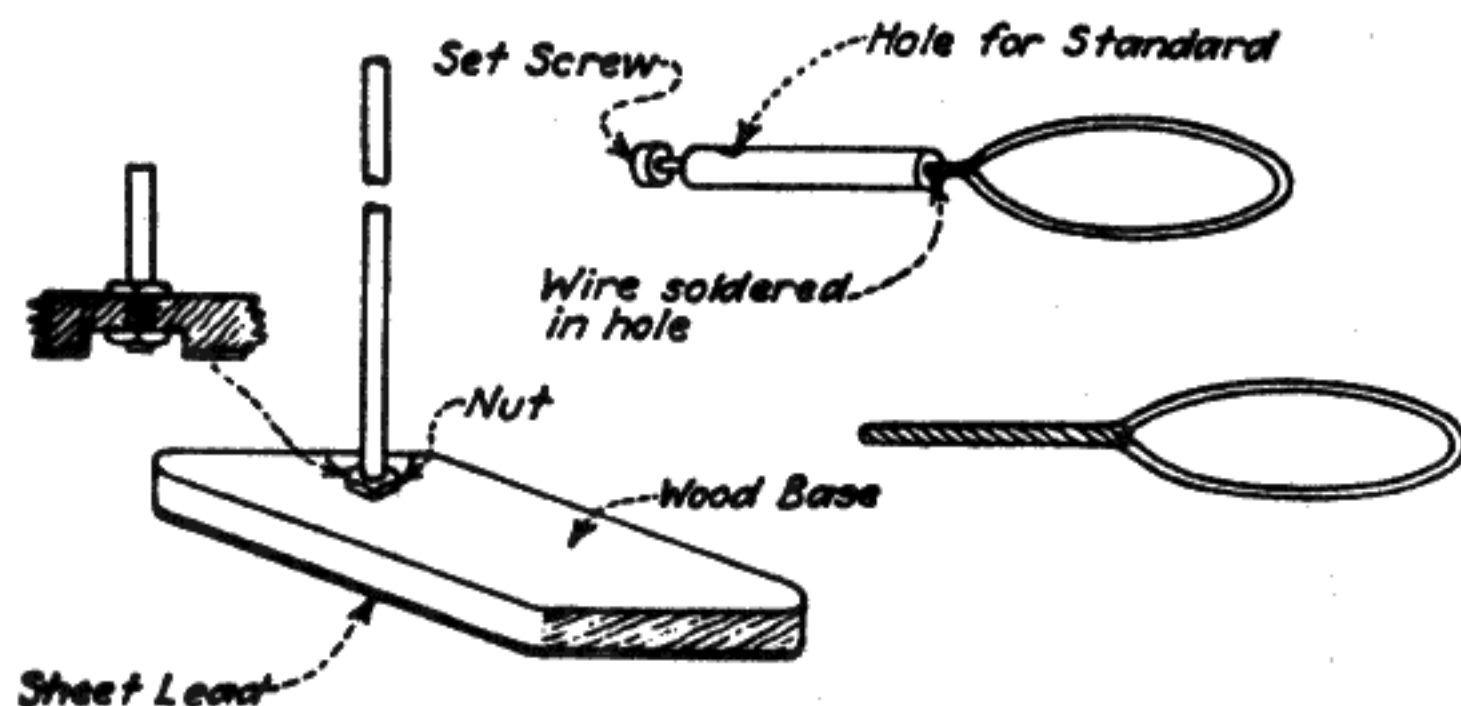

Fig. 14.—Details of a Home-made Laboratory Ring Stand.

stand should be cut to shape from wood and covered with sheet lead to give it sufficient weight so that the stand will not tip over easily when in use. The top

50

of the base should be covered with some acid-proof preparation. The standard is fastened to the base with two nuts as illustrated. The ring is very easily produced. The wire used should be very heavy so as to be able to hold its shape. The method of holding it in the brass piece which slips over the standard is clearly shown. About three of these rings should be made for different sized dishes and crucibles. A small piece of copper gauze is often used to place over the ring when very small dishes are being heated. Ring-stands are used very much about the chemical laboratory not only as a convenient holder for dishes being heated, but also for general apparatus set-ups.

A HYDROGEN SULPHIDE GENERATOR

A hydrogen sulphide generator is quite necessary for the small laboratory as this gas is used in many different ways. Hydrogen sulphide is generated when hydrochloric acid comes in contact with iron sulphide. These two compounds are used for the production of

51

the gas in what is known as a Kipp generator. The construction of a simple Kipp generator is shown clearly in Fig. 15. The bottle in which the students lamp chimney is placed should of necessity be one

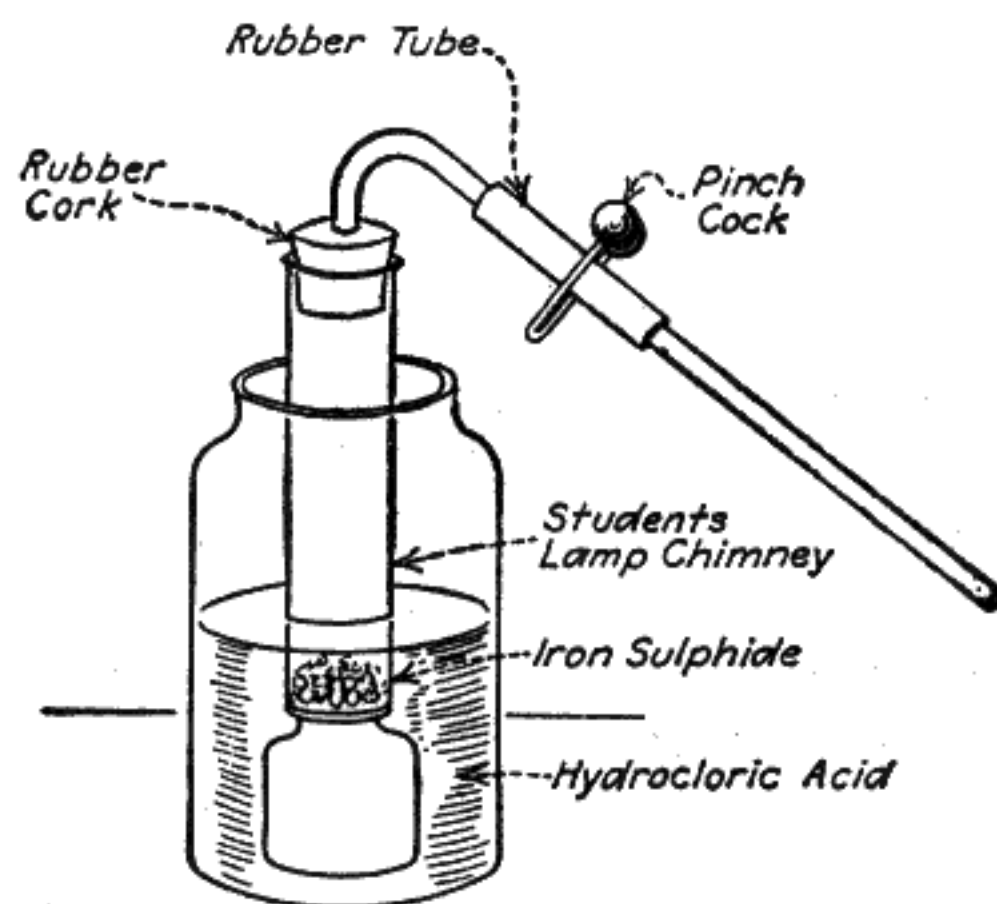

Fig. 15.—A Banks Hydrogen-Sulphide Generator.

with a very wide mouth. A large button is placed in the narrow part of the chimney. Chunks of iron sulphide are placed in the upper portion of the chimney. The remainder of the apparatus is very clear. The operation of the device is simple in the extreme. The larger bottle is half-filled with hydrochloric acid. The chimney is then placed in the bottle with the pinch-cock closed. The air is compressed in the chimney, which prevents the hydrochloric acid from reaching the iron sulphide. When the pinch-cock is opened, this air pressure is released and the hydrochloric acid succeeds in coming in contact with the iron sulphide. The following reaction occurs:



The hydrogen sulphide is forced out of the rubber tube. When enough of the gas has been produced, the pinch-cock is closed and the pressure of the H_2S increases until the hydrochloric acid is forced from the chimney.

NECESSARY APPARATUS

While the amateur chemist can make a great number of the necessary articles that should be in his laboratory, there are certain things which are quite beyond his facilities and ability. Fortunately, none of these articles are expensive. While some of the things in the following list could be made, they are so cheap that the author believes more time and trouble would be wasted on them than they are worth:

52

- 1 Test-tube holder.
- 1 Small evaporating dish.
- 1 Large evaporating dish.
- 1 Small fire-clay crucible.
- 1 Box of filter papers.
- 1 Graduated cylinder.
- 1 pound assorted glass tubing.

- 1 Thermometer, 200 degrees C.
- 1 Pipette.
- 2 Funnels (large and small).
- 1 Box of blue litmus paper.
- 1 Box of red litmus paper.
- 6 Beakers from 25 c.c. to 200 c.c.
- 4 Pinch-cocks.
- 1 Test-tube brush.
- 1 Water-bottle.
- 6 feet rubber tubing.
- 12 Large test-tubes.
- 12 Small test-tubes.
- 1 U-tube.
- 1 Thistle tube.
- 2 Erlenmeyer flasks.
- 1 Clamp for ring-stand.
- 2 Flasks.
- Mortar and pestle.

The reader will find in this list many articles about which he knows little or nothing.

There will be a few articles in the above list with which the amateur chemist is not familiar. For this reason a description will be given of each one.

53

TEST TUBES

A test tube is used to heat liquids and solids over a Bunsen burner. During the heating the top

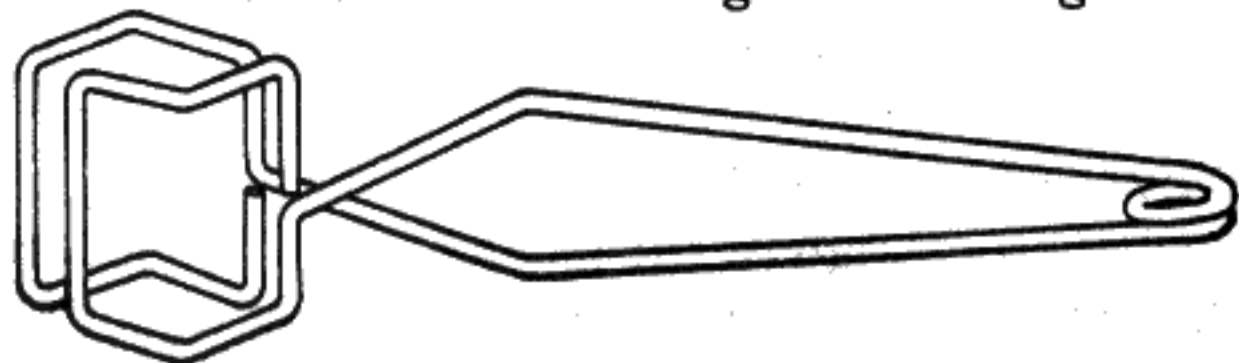

Fig. 16.—A Wire Clip Used for Holding Hot Test Tubes.

of the tube becomes so hot that it is impossible to hold it by hand. A little wire test tube holder as shown in Fig. 16 is used.

EVAPORATING DISHES

Evaporating dishes are used for a multitude of purposes. A small evaporating dish is shown in Fig. 17. The principal use of the evaporating dish is to evaporate liquids. For instance, if we had a solution of

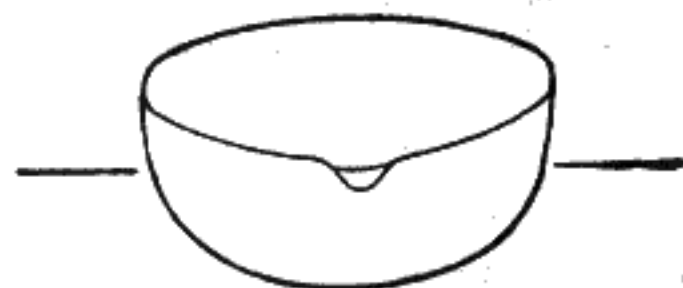

Fig. 17.—An Evaporating Dish Which is Generally Used for Boiling Purposes.

sodium chloride in water and we wished to obtain the sodium chloride in the original crystalline condition, we would place it in the evaporating dish and boil the water off, leaving the dry sodium chloride in the bot-

tom of the evaporating dish. Evaporating dishes are made of glass and possess considerable heat-resisting qualities. They are also impervious to anything but extremely sudden changes in temperature. Evaporating dishes are obtainable in various sizes.

FIRE CLAY CRUCIBLES

A small fire clay crucible of about 25 c.c. capacity is a useful little article to have about the laboratory and it is capable of standing much higher temperatures than ordinary glassware, and for this reason it can be used where ordinary chemical glassware would be unsuitable.

FILTER PAPER

Filter paper has an extremely important use. It is used for the filtration of any solution or liquid that has

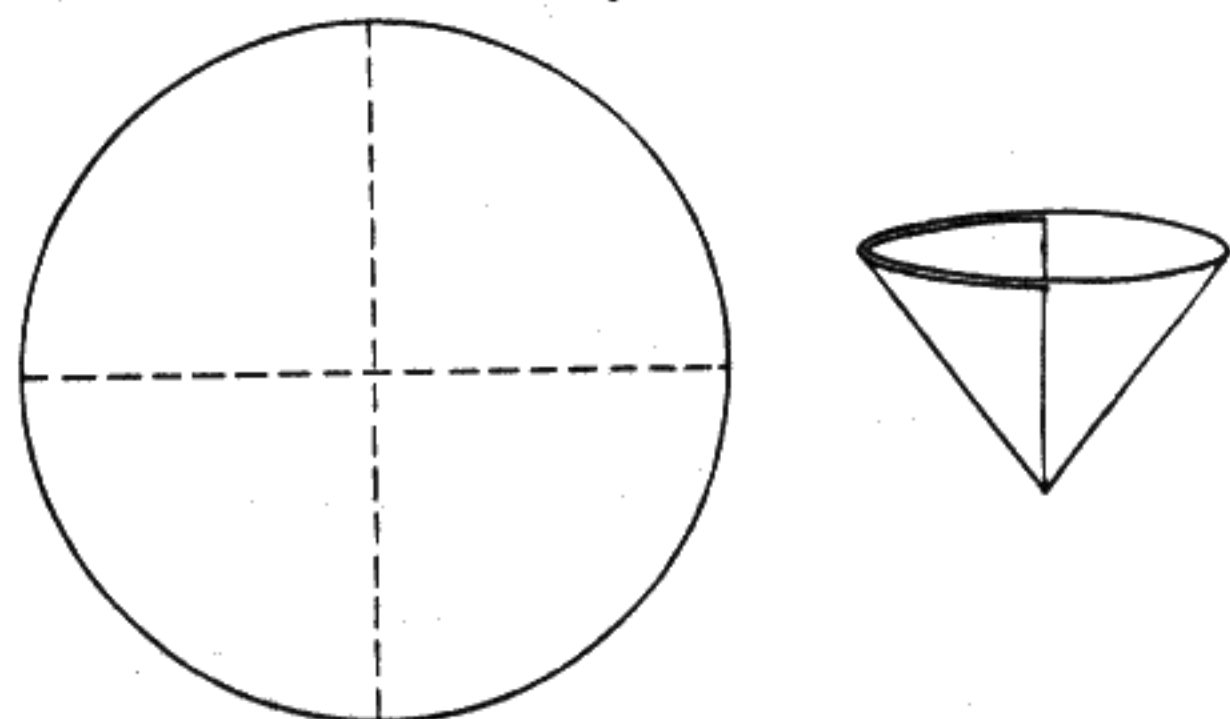

Fig. 18A—How Filtering Paper is Folded.

solid matter in it. The liquid is allowed to pass freely while the solid matter is arrested. Filter paper must

55

be chemically pure, and for this reason it is very carefully prepared for use. It comes in various sizes for use with different sized funnels. The use of filter paper will be very clearly seen by referring to Fig. 18A.

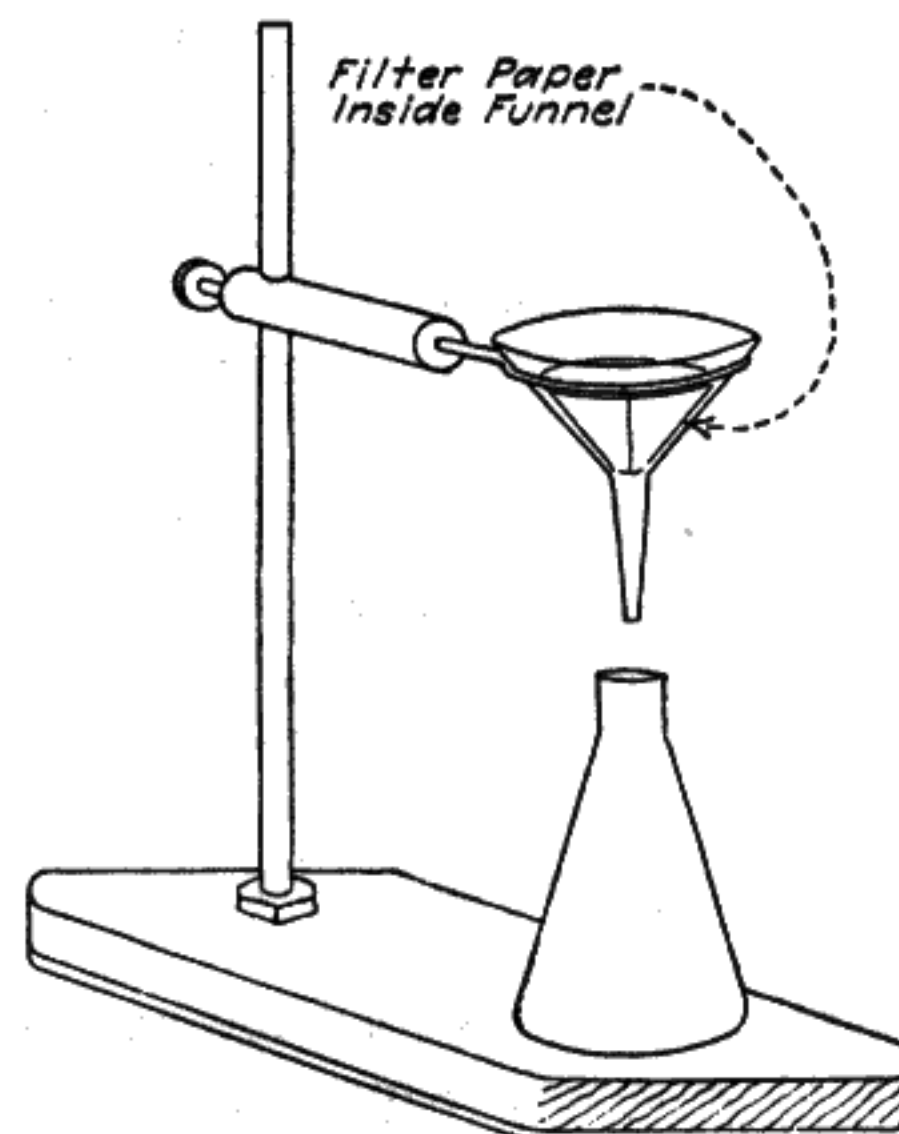

Fig. 18B—How Filtering Paper is Used.

The method of holding filter paper in place in the funnel is shown in Fig. 18B. The size of the filter paper would depend largely upon the size of the funnel that it is to be used with.

GRADUATED CYLINDER

A graduated cylinder is shown in Fig. 19. This is a much needed article about the laboratory. Each mark of the cylinder represents a cubic centimeter

56

and cylinders are obtainable with different capacities. 100 centimeters is a very good size for the amateur chemist and it should be included in his equipment.

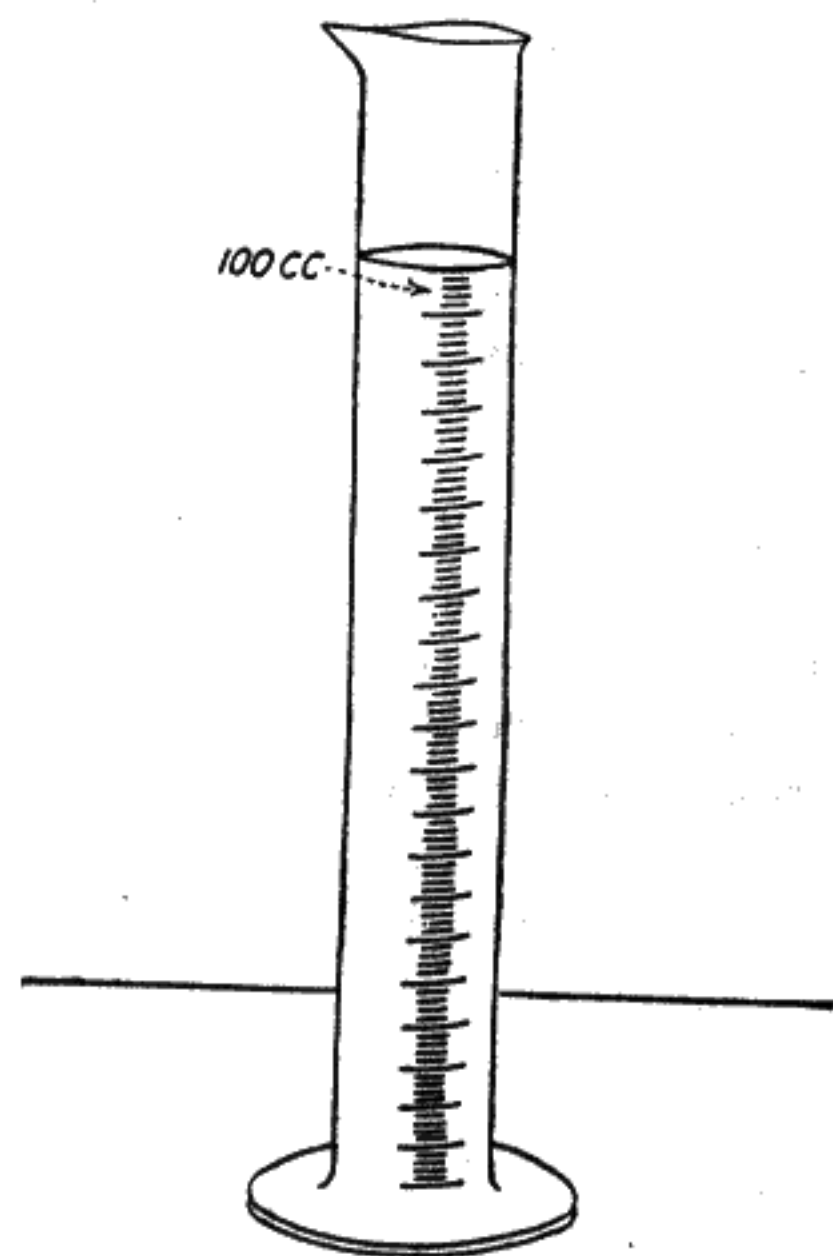

Fig. 19.—A 100 c.c. Graduated Cylinder Used in Measuring Liquids.

The cylinder is used largely for measuring off different solutions and liquids.

CHEMICAL THERMOMETERS

The chemical thermometer used in the small laboratory should be graduated in Centigrade degrees as the Centigrade system is considered more scientific than the Fahrenheit system, and therefore it finds more universal use in the world of science. A word of

57

caution about the use of the thermometer. If we have a liquid to boil and wish to bring it up to 100 degrees Centigrade, the thermometer should be placed in the liquid before the heat is applied so that the rise in temperature of the thermometer will be gradual. If we were to permit the liquid to reach 100 degrees and then place the thermometer in it, it would break immediately, due to the sudden change in temperature.

PIPETTE

A pipette is a very simple device and one is shown

in Fig. 20. This is used for conveying liquid from one receptacle to another. One end of the pipette is

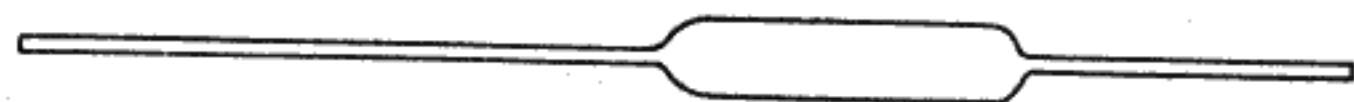

Fig. 20.—A Pipette, the Use of Which is Described in the Text.

placed in the mouth and the other end in the liquid to be taken into it. By sucking gently on the end of the pipette the liquid will rise into it. If a particularly poisonous liquid is being handled, care should be taken that none of it is drawn into the mouth.

RED AND BLUE LITMUS PAPER

Red and blue litmus paper is used for testing alkaline and acid solutions. For instance, if we had a solution and wished to know whether it was a base or acid, we would take a piece of red or blue litmus paper and dip it in it. If the red paper turned blue it would indicate a base. If it remained red we would not know whether or not it was neutral or alkaline. Therefore, we would try it with blue litmus paper. If the blue litmus paper would turn red we would then under-

58

stand that it was an acid solution. If neither the red nor blue litmus paper changed in color we would understand that the solution being tested was neutral.

BEAKERS

A beaker is shown in Fig. 21. At least 6 of these should be in the student's laboratory. Beakers are used for various purposes. Reactions are permitted

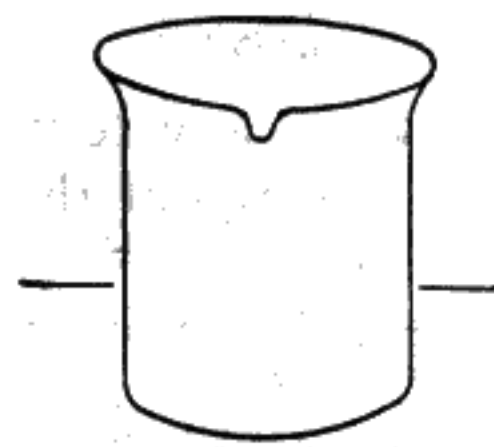

Fig. 21.—A Small Beaker Which Finds a Multitude of Uses in the Chemical Laboratory.

to take place in them, precipitates are formed in them and they are also used for heating purposes. A beaker is a very convenient receptacle to handle and liquids are very easily poured from them.

PINCH-COCKS

Pinch-cocks are used in connection with rubber tubing to either cut off a supply of liquid or gas. The pinch-cock merely presses the tube together and holds it tightly so that nothing can pass. Owing to the nature of the rubber perfectly gas tight and liquid stoppage is made.

A test tube brush is shown in Fig. 22. This is used

for the purpose of cleaning out dirty test tubes. In ordinary cases water will do very nicely for cleaning out the tubes, but if a particularly clean receptacle is

59

desired for an extremely accurate chemical determination, the tube should first be washed out with water and this should be followed with sulphuric acid. Sul-



Fig. 22.—A Small Brush Used in Cleaning Test Tubes.

phuric acid is then carefully washed out with water and the final washing is made with ethyl alcohol, after which the tube is allowed to dry.

Thistle tubes are extremely simple and one of their

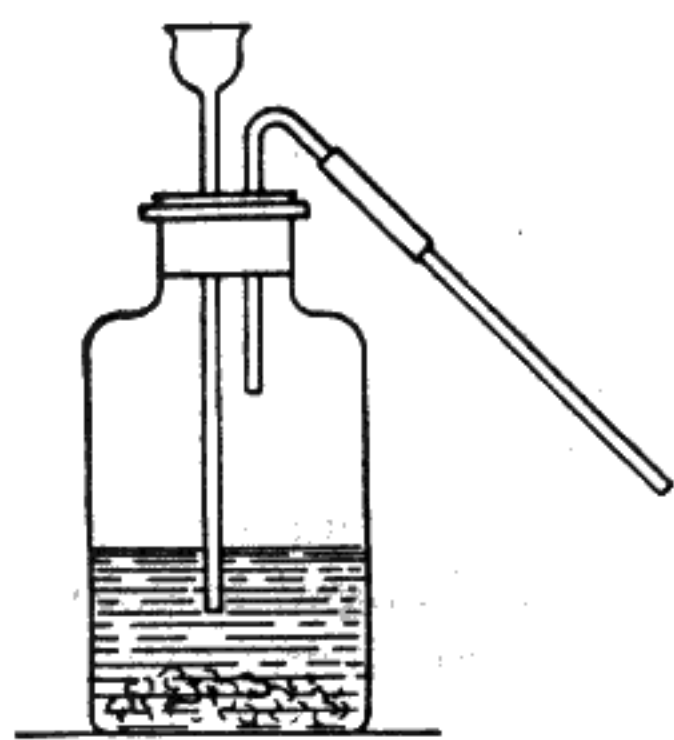

Fig. 23.—Showing the Use of a Thistle Tube.

uses is shown in Fig. 23. Thistle tubes cost but a few cents each and one should be in the laboratory of every chemical student.

FLASKS

An Erlenmeyer flask has a wide variety of uses and it is advisable to include two of these in the general chemical equipment. They are often used with a rubber cork into which either one or two glass tubes are

60

placed. The flask when arranged in this way would become an important part of many different apparatus

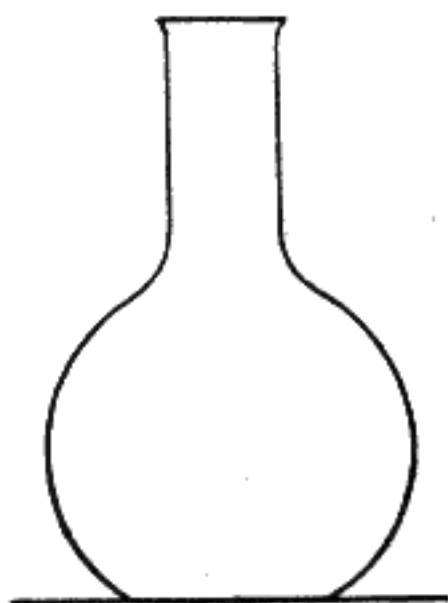

Fig. 24.—A Flask Which is Greatly Used in Chemical Laboratory Work.

set-ups. Flasks similar to those shown in Fig. 24 are very important.

WASH BOTTLE

One use to which such a flask can be put is that of forming a wash bottle. A simple wash bottle can easily be made by the student and one is shown in

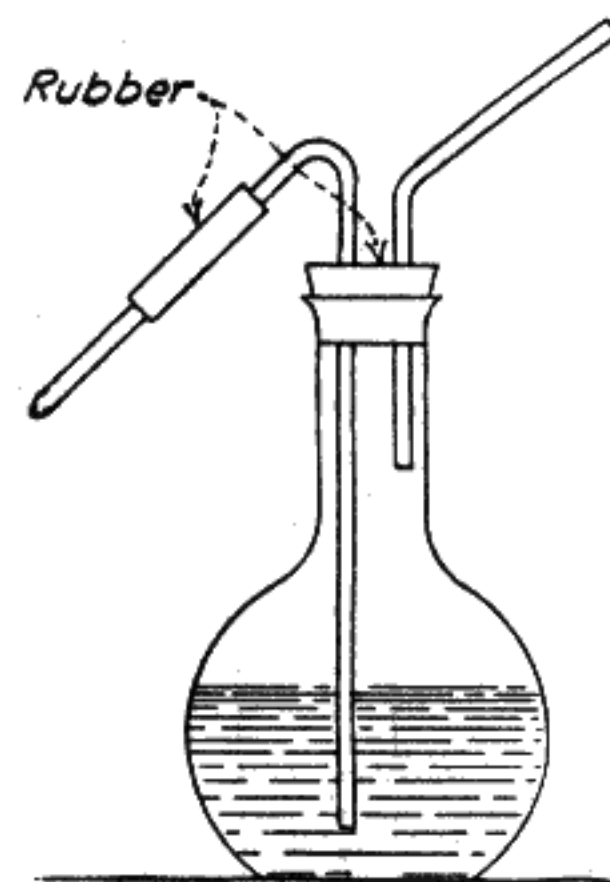

Fig. 25.—A Wash Bottle That Can be Assembled by the Home Chemist.

61

Fig. 25. It will be seen that by blowing on the one tube the pressure is developed on the surface of the water and the water is forced out of the other tube. Here is an instance where the bottle can be used. We will assume that we are filtering solid matter from the solution. If the solution is passed through the filter paper the solid matter will be left about the sides of the paper. Being that it is the solid matter and not the solution that we wish to obtain it will be necessary to wash the solid matter down into the bottom of the filter paper. This is done very carefully with the wash bottle.

CLAMPS

A clamp for use in connection with the ring stand that was described in a previous part of this book is shown in Fig. 26. These clamps have a very wide use

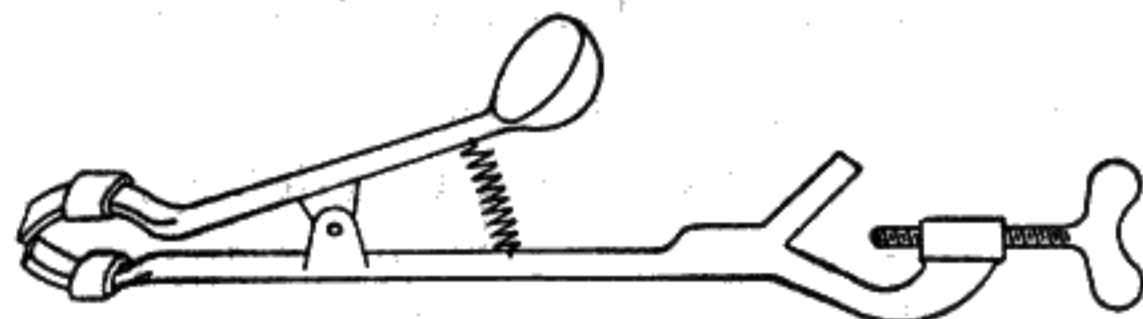

Fig. 26.—A Clamp to be Used in Connection With the Ring Stand.

and they come in extremely handy for many different purposes. For instance, they can be used for gripping test tubes, flasks and glass tubing.

CHEMICALS FOR THE LABORATORY

We now come to a consideration of the chemicals with which the small laboratory should be equipped. Many of these compounds can be obtained at the corner drug store, but it will be necessary to purchase the majority from some chemical supply house.

62

Copper sulphate (CuSO_4), $\frac{1}{4}$ lb.
 Sodium nitrate (NaNO_3), $\frac{1}{4}$ lb.
 Sodium carbonate (Na_2CO_3), $\frac{1}{4}$ lb.
 Potassium carbonate (K_2CO_3), $\frac{1}{4}$ lb.
 Potassium nitrate (KNO_3), $\frac{1}{4}$ lb.
 Sulphuric acid (H_2SO_4), $\frac{1}{2}$ pt.
 Hydrochloric acid (HCl), $\frac{1}{2}$ pt.
 Nitric acid (HNO_3), $\frac{1}{2}$ pt.
 Sulphur (S), $\frac{1}{2}$ lb.
 C.p. zinc (Zn), $\frac{1}{4}$ lb.
 Copper filings (Cu), 2 oz.
 Iron filings (Fe), 2 oz.
 Ammonia (NH_3), $\frac{1}{2}$ pt.
 Ammonium chloride (NH_4Cl), $\frac{1}{4}$ lb.
 Sodium chloride (table salt) (NaCl), $\frac{1}{4}$ lb.
 Potassium chlorate (KClO_3), $\frac{1}{4}$ lb.
 Manganese dioxide, 2 oz. MnO_2 .
 Calcium chloride (CaCl_2), $\frac{1}{4}$ lb.
 Sodium hydroxide (NaOH), 2 oz.
 Potassium hydroxide (KOH), 2 oz.
 Magnesium ribbon, 2 oz. Mn .
 C.p. aluminum (Al), 3 oz.
 Charcoal, C $\frac{1}{2}$ bb.
 Ethyl alcohol ($\text{C}_2\text{H}_5\text{O}$), $\frac{1}{2}$ pt.
 Mercury, Hq., 6 oz.
 C.p. tin (Sn), 3 oz.
 C.p. lead (Pb), 6 oz.
 Mercuric oxide (HgO), 4 oz.
 Ferric oxide, $\frac{1}{4}$ lb.

63

PART III

CHEMICAL EXPERIMENTS

Preparation of Oxygen—Breaking Glass Tubing—Catalytic Agents—Experiments with Oxygen—Production of Chlorine—Experiments with Chlorine—Neutralization—Distillation of Water—Practical Distillation—Thermit—A Small Electric Furnace—Furnace Connections—Experiments in Catalysis—Negative Catalysis—Detecting the Presence of Carbon Dioxide—Production of Calcium Carbonate—Electrolytic Production of Lead Carbonate—Production of Nitric Acid—Colloidal State of Matter—Crystalloidal and Colloidal Solution—Electrolysis of Water—Generation of Hydrogen in Quantities—Glass Working for Amateur Chemists—Cutting and Breaking—Drilling—Smoothing Rough Edges—Bending Glass Tubing—Cutting Glass Tubing—Drawing Glass Jets—Sealing a Platinum Wire in Glass—Joining Tubing and Making Tees—Spreading the Ends of Tubing—Glass Spiral Tubes—Miscellaneous Information.

Now that we have our chemical laboratory partly equipped, we will conduct a few experiments that will not only broaden our knowledge of chemistry but will assist us in understanding the manipulation of chemical apparatus. During these experiments it will be necessary to add to the equipment of the laboratory

by making several new adjuncts. These will be described with the experiment with which they are used.

PREPARATION OF OXYGEN

The first experiment will be the preparation of oxygen. We understand that there is a great abundance of oxygen in the air, but here it forms a physical

64
 combination with the other atmospheric gases, notably among them nitrogen.

Oxygen can be produced in a free, undiluted state by the decomposition of potassium chlorate (KClO_3). The decomposition is brought about merely by breaking it up into potassium chloride and oxygen. The arrangement of the apparatus necessary to carry out the

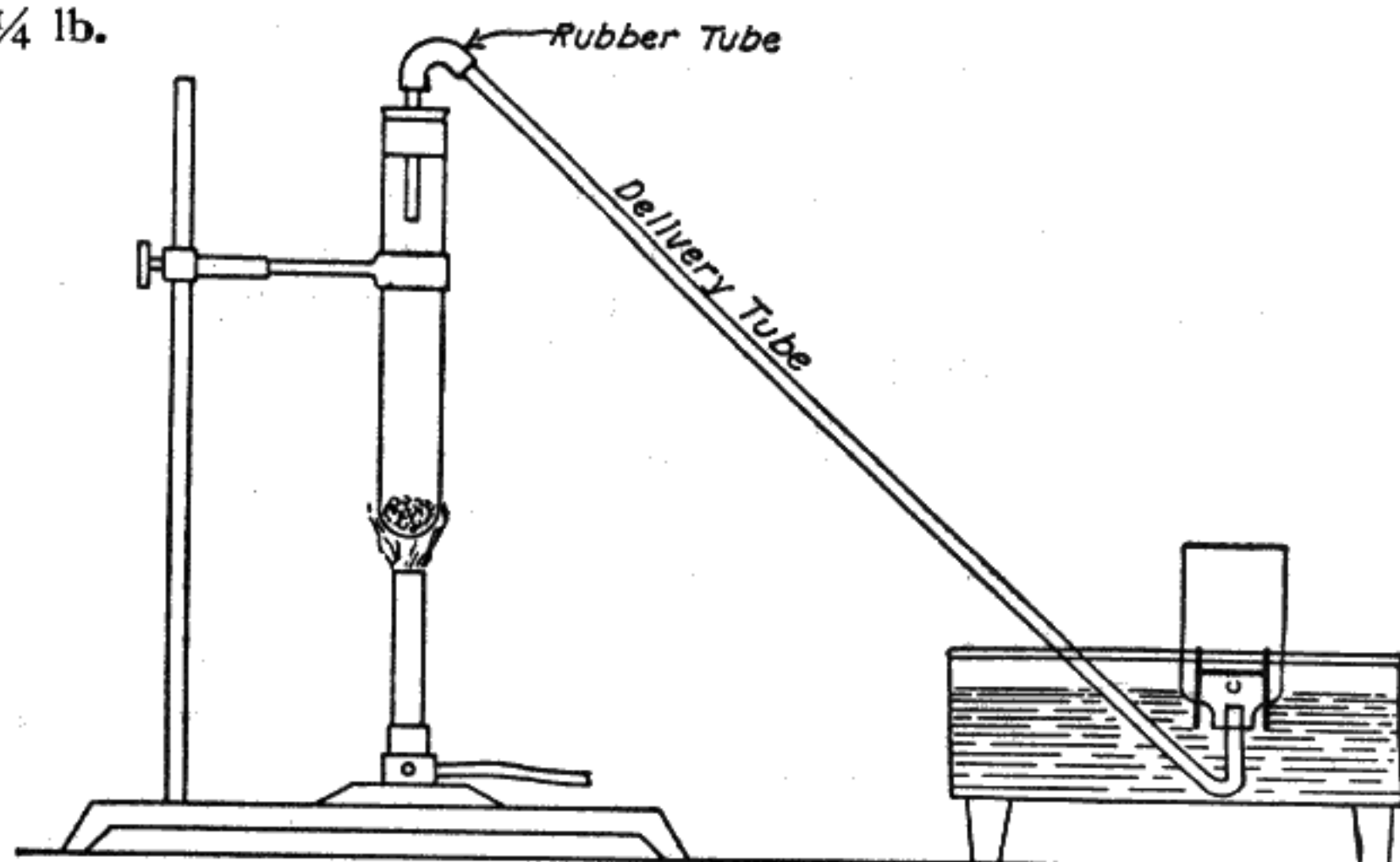

Fig. 27.—Apparatus Necessary for the Generation of Oxygen.

experiment is shown clearly in Fig. 27. The pneumatic trough is a simple device and is used for collecting gases. The collecting receptacle is so arranged in the pneumatic trough that the water keeps the receptacle continuously sealed so that no gas can escape. The gas bubbles through the water into the mouth of the receptacle. The pneumatic trough can be made easily by the amateur chemist. The dimensioned drawing which forms Fig. 28 will give all the necessary details.

65

BREAKING GLASS TUBING

In setting up the apparatus necessary for the experiment of producing oxygen, it will be necessary to break some glass tubing. There is a certain way to do this. First, the glass is nicked with a three-cornered file at the point where it is to be broken. It is then gripped in the hands as shown in Fig. 29. With the thumbs placed in this manner the tube is broken by a quick motion. On small tubing under $\frac{3}{8}$ inch diameter, a nice clean break will be produced in this way.

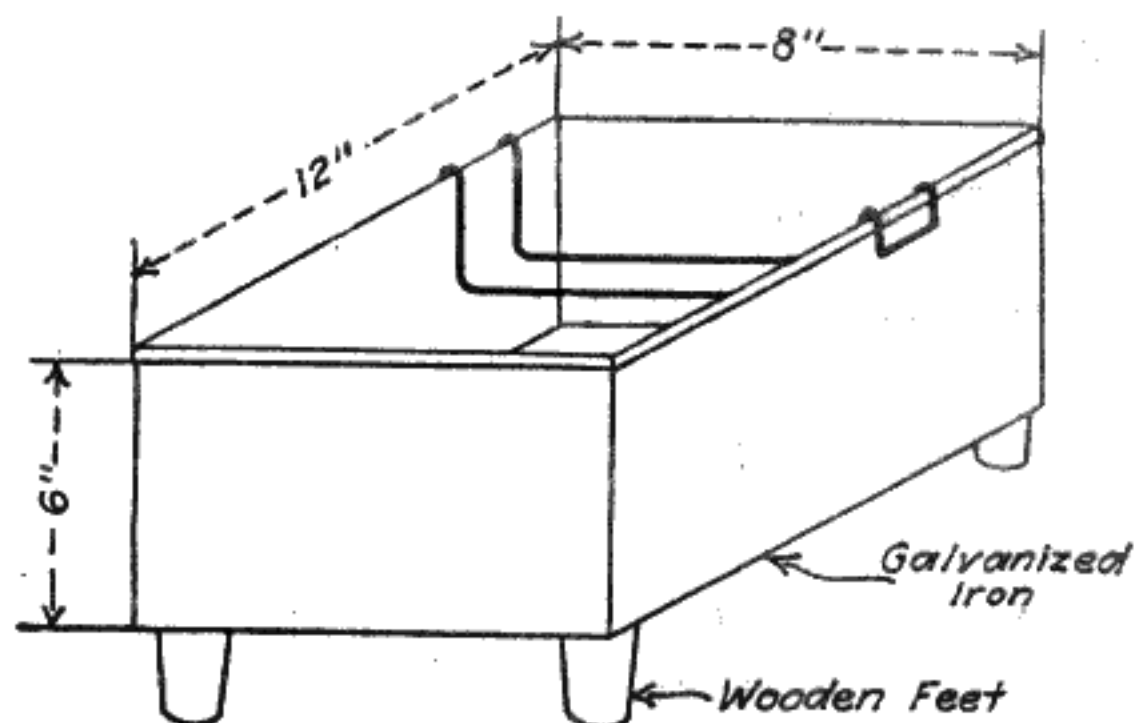

Fig. 28.—Dimensions of a Small Pneumatic Trough.

CATALYTIC AGENTS

We are now ready to continue with the experiment. While potassium chlorate will evolve oxygen at a temperature well above 300° Fahr., it can be made to give it off at a much lower temperature (200° Fahr.) by mixing it with one-third of its weight of manganese dioxide. After the potassium chlorate is completely decomposed, we are surprised to find that the manganese dioxide is left quite unchanged. Was it the

66

mere presence of the compound that accelerated the decomposition of potassium chlorate? This is true. The manganese dioxide in this case is called a catalyzer or a catalytic agent. We may define a catalytic

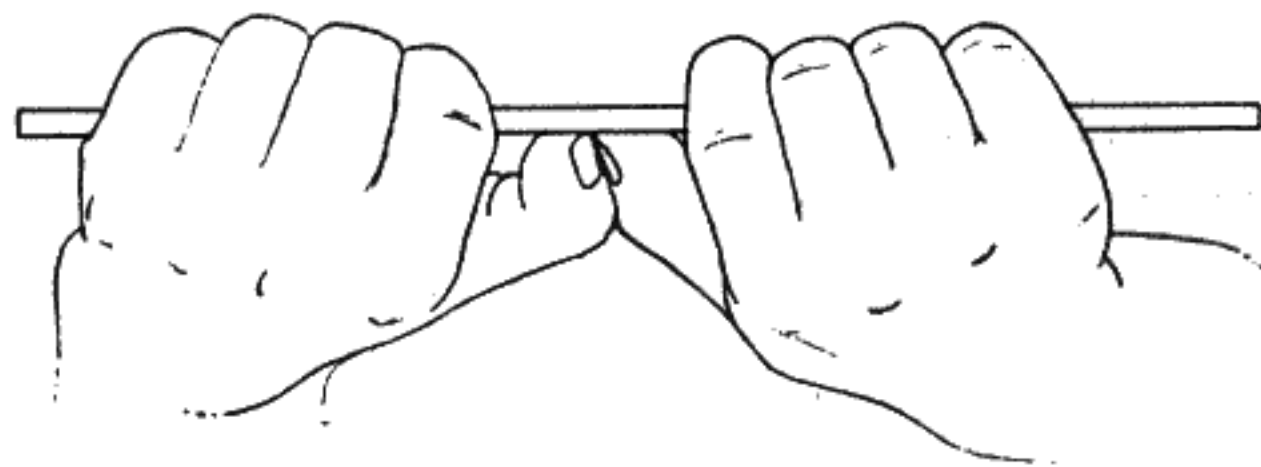

Fig. 29.—How Small Glass Tubing is Held When it is to be Broken.

agent, then, as a substance, which by its mere presence, causes a chemical reaction to take place. The presence of platinum or mercury in hydrogen peroxide (H_2O_2) causes it to decompose into water and oxygen.

EXPERIMENTS WITH OXYGEN

Having produced the oxygen, many interesting experiments can be performed by its aid. Oxygen is an extremely active element. It combines with all but a few of the elements to form oxides. This process is called oxidation. If we heat a piece of soft iron wire to redness and introduce it in the bottle of oxygen, it will become intensely hot and burn (oxidize) with a shower of tiny sparks. If a match is lit and the flame extinguished, it will be reestablished as the match is introduced into the bottle immediately after the flame is extinguished. Many other similar interesting experiments can be performed with oxygen. The reader

67

will become familiar with these when he extends his chemical studies beyond the confines of this book.

PRODUCTION OF CHLORINE

The next experiment will be that of producing the gas chloride. A word of caution will be advisable here. Chlorine is a very poisonous gas and the experimenter should not inhale any if possible. Of course, a little will escape into the air and it will be

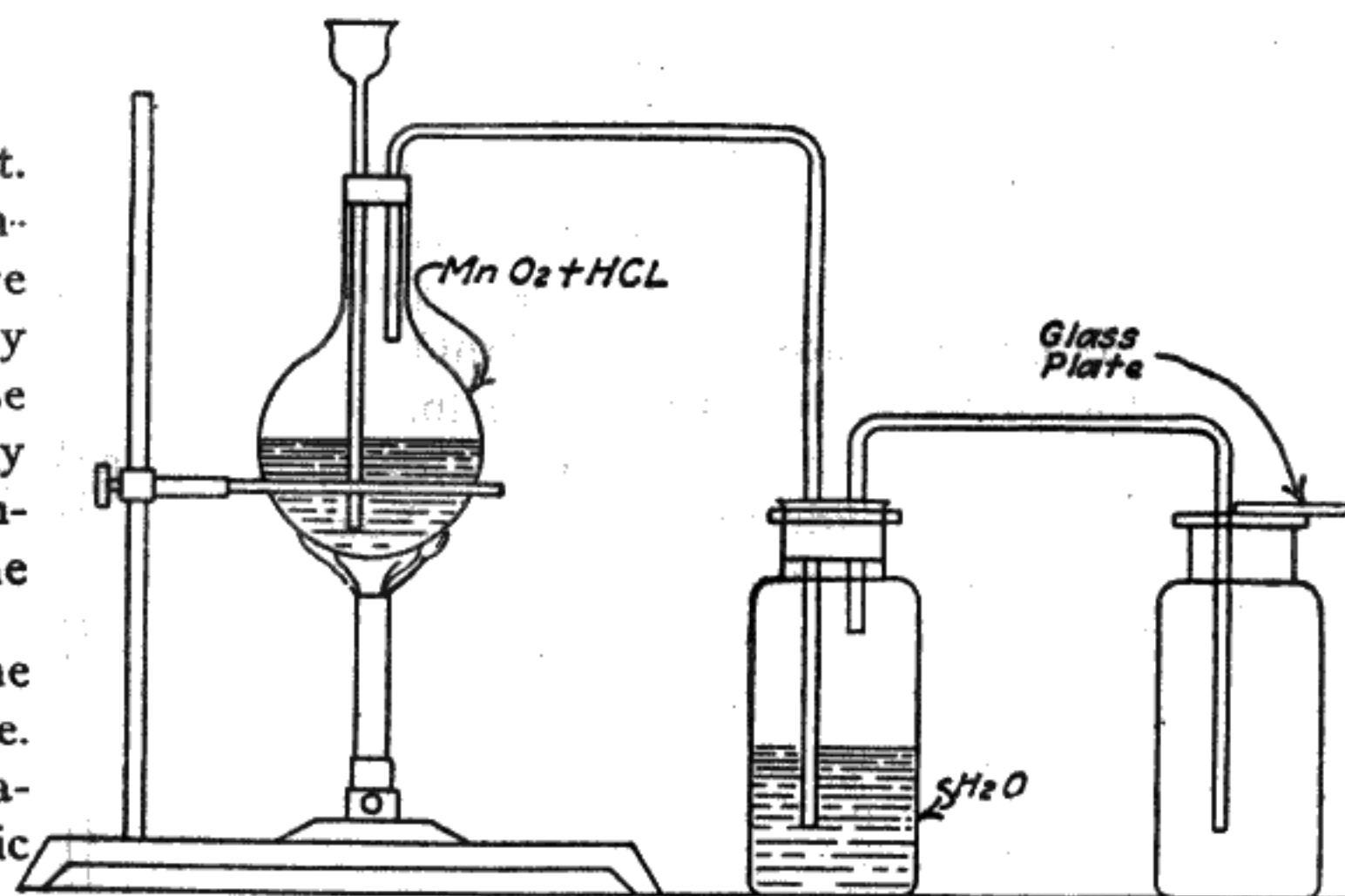
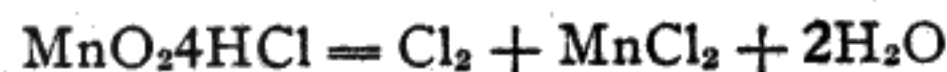

Fig. 30.—Apparatus for the Generation of the Gas Chlorine.

detected by its smell. Small quantities are not dangerous. The set-up of the necessary apparatus is shown in Fig. 30. This is a simple arrangement. The thistle tube is merely arranged to act as a safety valve should the outlet for the gas become plugged. The gas is greenish yellow in color and will rise from the surface of the hydrochloric acid in small clouds. The

68

following reaction takes place between the hydrochloric acid and manganese dioxide:



There are really three products of this reaction: water, chlorine and manganese chloride.

EXPERIMENTS WITH CHLORINE

Chlorine is a notable bleaching agent. In fact, it finds a great commercial use for this purpose. The bleaching properties of chlorine can be very easily demonstrated by placing a piece of wet calico in the jar containing the free gas. If the cloth is left there long enough, it will be bleached almost white when it is taken out.

Chlorine is somewhat soluble in water. If some of the gas is dissolved in water and exposed to sunlight, the following reaction takes place, the sunlight acting as a "catalytic" agent:

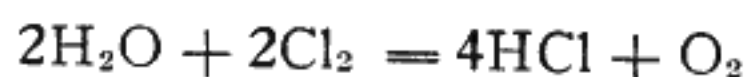

Here we find the production of hydrochloric acid and free oxygen.

NEUTRALIZATION

Next, we will try a little experiment in neutralization. We will take a small quantity of dilute acid (any kind) in a test tube. After the acid, we will pour in a like amount of an alkaline solution. Sodium hydroxide (NaOH) will do nicely for this purpose. After this, we will test the solution with litmus paper to see whether it is acid or alkaline. If it is acid, we will add a little more of the NaOH. If it is alkaline, we will add a little more acid. The acid or alkaline solution should be added in very small quantities until

69

a point will be reached where the red litmus will remain red and the blue litmus will remain blue. This indicates that a neutral solution has been produced. This solution can be changed either way by the addition of a slight amount of either an acid or a base. If a half drop of acid is added, the solution will immediately become acid, as will be indicated by litmus paper.

DISTILLATION OF WATER

The next experiment will be that of distilling water. The author decided to treat this not so much as an interesting experiment, but to convey to the reader the principles of distillation and condensation. If we had

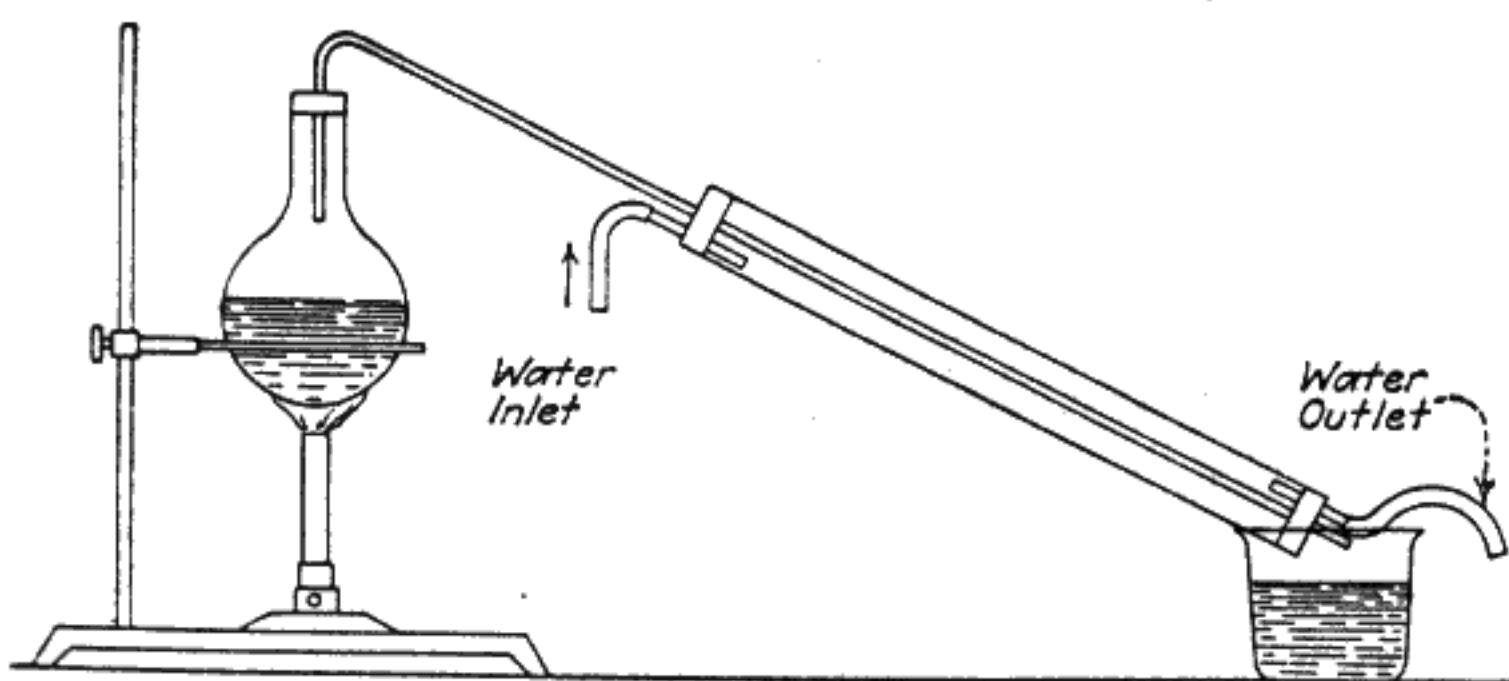

Fig. 31.—Showing Apparatus Used for Distilling Water in the Laboratory.

a vapor rising off a boiling solution which we wished to obtain in the liquid state, we would proceed in the same way that we are proceeding with the water.

The apparatus necessary for the distillation of water is shown in Fig. 31. The condenser is a simple device and is in need of very little description. It consists of a large glass tube with a rubber cork in each end. Two holes are in each of the rubber corks to permit

70

the two glass tubes shown to pass. Running water is made to circulate through the condenser by means of the tubes A and B.

When the water reaches the boiling point in the receptacle, its vapor passes off into the glass tube that passes through the condenser. This tube is kept cool and the water vapor or steam condenses to water when it enters. The condensed water runs into the receptacle.

FRACTIONAL DISTILLATION

If we had a mixed solution and we desired to separate the various constituents, it could be done by a process of distillation. All substances have a different vapor pressure or temperature of evaporation, we may say. If we had a solution of alcohol and water which we wanted to separate, we would heat the liquid slightly to evaporate the alcohol, and then increase the temperature to evaporate the water. This process is called fractional evaporation.

THERMIT

A simple experiment in high temperature can be made with a little iron oxide and powdered aluminum. The aluminum can be the kind used in aluminum paint. This is very flaky and will be very suitable for the purpose. A small carbon or graphite crucible will also be needed to conduct the experiment properly. The aluminum and iron oxide are placed as shown. (Fig. 32.) The aluminum and iron oxide are mixed in equal proportions. The magnesium ribbon is used to start the reaction, which is based upon the great "affinity" of aluminum for oxygen. The iron oxide loses its oxygen to the aluminum. The reaction takes

71

place with great violence and a temperature in the neighborhood of 3000° C. is produced momentarily. When the reaction is completed, a small pillet of

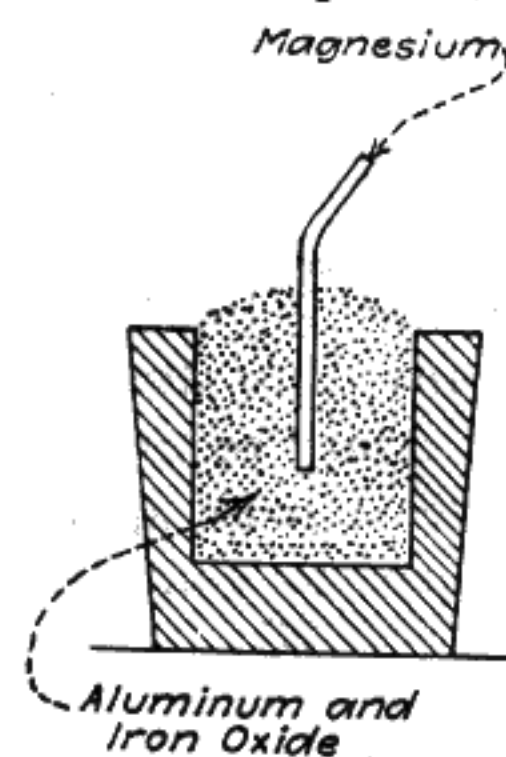

Fig. 32.—How Thermit is Ignited.

molten iron will be left in the bottom of the crucible. Many of the metallic oxides can be reduced in this way to obtain the pure metal.

A SMALL ELECTRIC FURNACE

A small electric furnace will make a valuable addition to the experimenter's laboratory. It will provide

him with means of conducting many interesting experiments that would otherwise be quite impossible. The ensuing description is of a small laboratory furnace.

The body and crucible of the furnace (see Fig. 33) will be considered first. The body is made from half a standard brick of some good heat-insulating material of considerable refractory endurance. There are several good brands of refractory bricks on the market, such as Sil-O-Cel, Nonpareil, Osceola, etc. A hole $1\frac{1}{2}$

72

inches deep is chiseled in the center of the brick. A groove is then cut through the center of the brick to accommodate the electrodes, as shown in the drawing. As the electrodes are $\frac{1}{2}$ inch in diameter, this groove

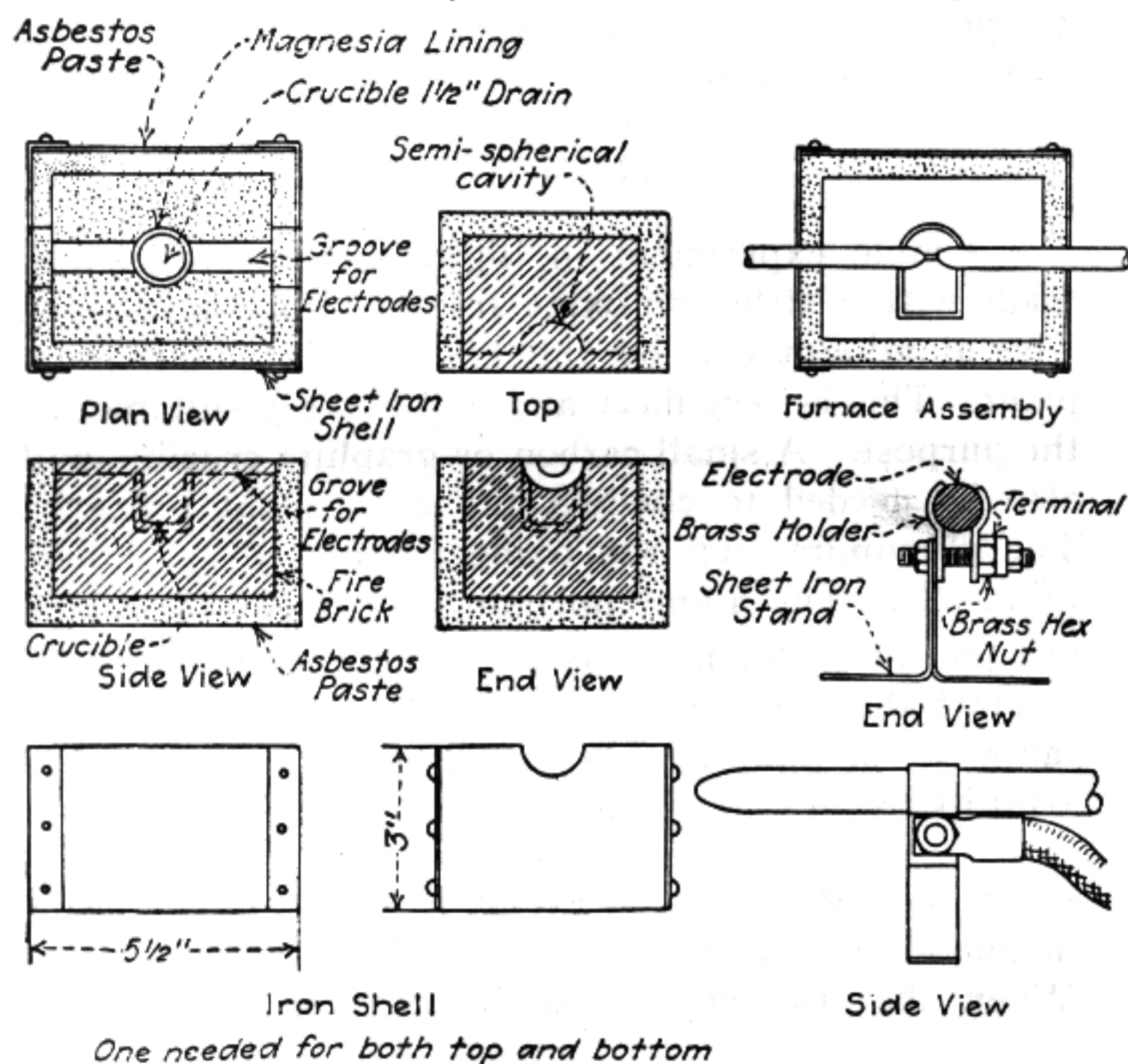

Fig. 33.—Details of a Small Electric Furnace for Use in the Chemical Laboratory.

should be just a trifle larger than $\frac{1}{2}$ inch. The cavity in the center of the brick is lined with magnesia which may be obtained at any drug store. Being in the powdered form, it is necessary to mix it with some bonding material. While it may appear peculiar to the builder, either molasses or common syrup is used as

73

the bond. The magnesia is mixed into a thick, consistent paste and applied to the walls and bottom of the cavity or crucible of the furnace. The whole brick is then placed in a hot oven and allowed to remain until the magnesia lining becomes baked. To carry this baking further and to completely remove all the volatile organic constituents of the bond, an arc is established directly over the cavity to thoroughly heat the magnesia. Silicate of soda may also be used successfully as a bonding substance.

An outer casing of stove-pipe iron is now made for the furnace. This is made $\frac{1}{2}$ inch larger than the refractory brick so that the brick can be placed in the casing and the intervening space between the two filled with some good heat-insulating material. Heat insulation is a prime factor in designing laboratory furnaces. The heat produced in a furnace escapes very readily, and if high temperatures are to be produced the furnace must be properly insulated. The thermal resistivity of contacting surfaces is very high, therefore a small furnace should have several different layers of refractory or heat-insulating substances in its body. The great thermal resistance of contacting surfaces is the reason it takes an onion so long to boil. The heat-insulating substance used between the shell or casing and the brick of the furnace need not have a high refractory power. Ordinary asbestos paste will do very nicely. If the little furnace is not provided with an outer covering of a heat-insulating substance, it will operate at a very low point of efficiency, as the surface radiation will account for a dissipation of heat as fast as it can be produced beyond a certain temperature of the arc.

A cover of high refractory power is now made. The builder should take great care in making this cover. It should fit as accurately as possible in order to pre-

74

vent dissipation of heat from the crucible. The other half of the brick used in making the body of the furnace may be employed for the cover. The cavity and two grooves are cut in the brick as shown. The cavity is lined with magnesia and made in a semi-spherical form so that the heat of the arc will be reflected from the surface of the cavity downward into the crucible. Heat waves are reflected just as the shorter ether waves of light. The whole cover is then placed in the stove-pipe iron shell with asbestos paste, just as the body was.

The electrode holders are made rugged and heavy, but of simple design. These are plainly shown in the drawing. If the builder alters this electrode holder design, he is cautioned to provide means of establishing a firm, low resistance contact between the electrode and the feed cable. With a low pressure and high current strength, a poor contact will heat badly and cause a lowering of working efficiency. The electrodes should be of carbon $\frac{1}{2}$ inch in diameter. They are adjusted by pushing them in or out of the furnace. The advantages of an electrode adjusting device do not justify the trouble of its construction. The electrodes and terminals rest on the sheet iron standard as shown. The furnace sits on a slab of $\frac{1}{2}$ -inch slate.

FURNACE CONNECTIONS

A suitable transformer for use with a furnace of this

type should have a core that measures 10 inches long, 8 inches wide made up of strips of iron $2\frac{1}{2}$ inches wide. The thickness of the core should be $2\frac{3}{4}$ inches. The secondary of the transformer consists of fifty turns of doubled No. 10 magnet wire. The primary consists of 150 turns of No. 14 magnet wire. The con-

75
nections for the furnace and transformer are shown in Fig. 34. If the transformer is not used, the furnace

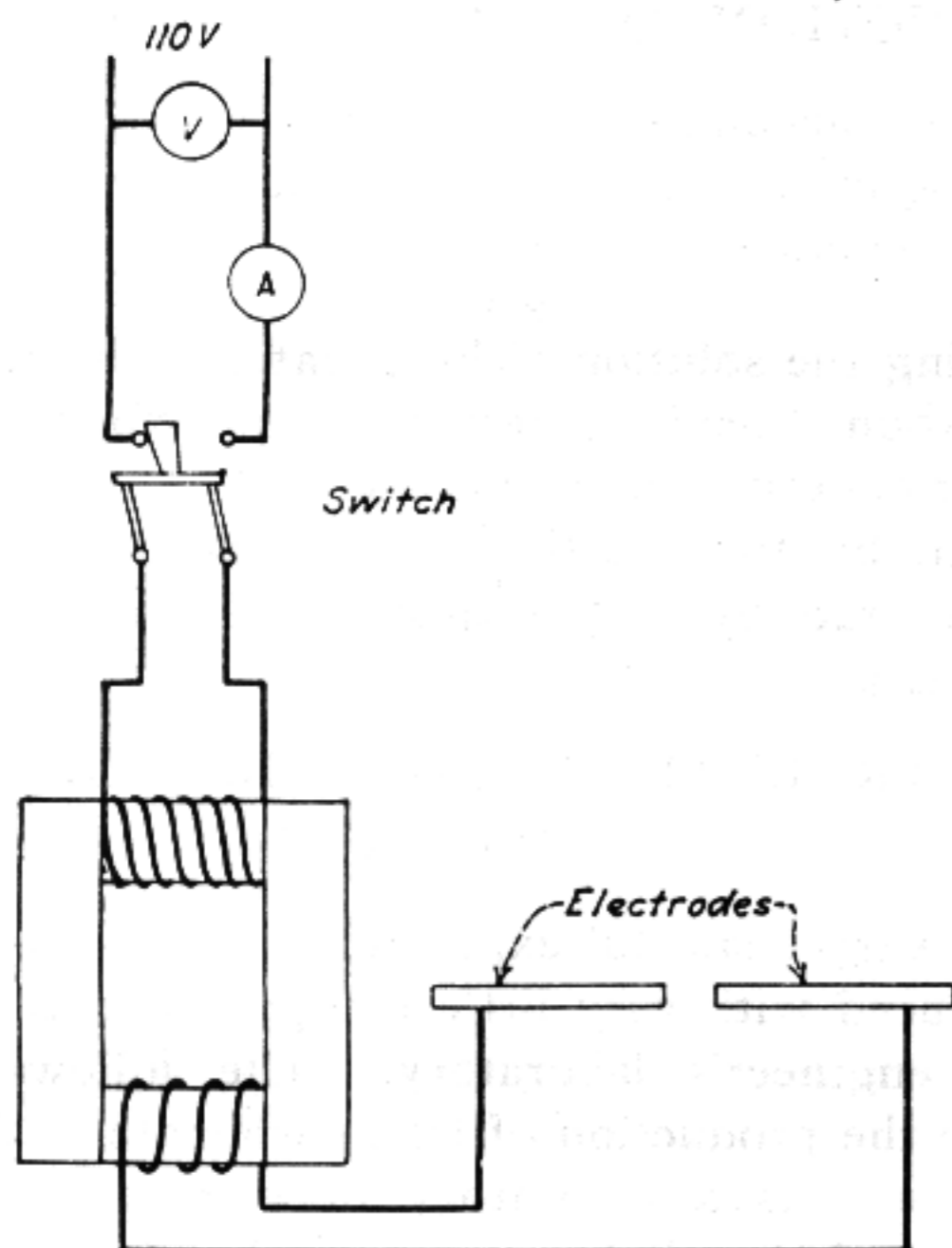

Fig. 34.—How the Electric Furnace is Connected With a Suitable Transformer.

can be run in connection with a water rheostat as shown in Fig. 35.

EXPERIMENTS IN CATALYSIS

A few experiments in catalysis will give the reader a broader understanding of this wonderful process. Probably one of the most beautiful experiments in catalysis is that of the decomposition of hydrogen peroxide (H_2O_2) by the catalytic influence of mer-

76
cury. If a little clean mercury is placed in a test tube and a small amount of a 10 per cent solution of hydrogen peroxide poured over it, the hydrogen peroxide will at once begin to decompose into water and oxygen. The decomposition, however, is not continuous, but periodic. If we watch the tube closely, we will see a little gaseous cloud burst from the surface at regular intervals—vibratory decomposition taking place with chronological accuracy! If our eyes were only powerful enough to see; if our intelligence were only great enough to comprehend! The mercury is seemingly impotent, yet what mysterious power it possesses. But mercury is not the only substance whose "presence" will cause hydrogen peroxide to break up into water and oxygen. Finely divided plat-

inum or pyrolusite will bring about the same change.

Such an ordinary substance as water is a wonderful catalyst for certain reactions. Thus, carbon monoxide and oxygen will react with explosive violence if ignited in the presence of water vapor. If the water vapor is completely removed from these gases, however, they absolutely refuse to combine.

It is amazing to learn what minute quantities of catalytic agents are capable of effecting certain chemical reactions. It requires about .0045 gram of platinum to cause the union of twelve parts of oxygen and hydrogen. But this is a comparatively large amount when it is considered that .000,000,000,1 of $\frac{1}{4}$ of an ounce of copper sulphate will effect a certain reaction.

In the foregoing paragraphs we briefly considered chemical catalysis. We will now deviate a little and learn a few of the wonders of a similar phenomena called "physical catalysis."

There are two chemical derivatives of the element chromium, called chromic chloride and chromous chloride. The "ic" on chromic and the "ous" on

77

chromous each signifies a different chemical composition. Chromic chloride, a beautiful violet crystalline substance, is what the chemist calls insoluble; it refuses to dissolve in water no matter how much it is shaken or agitated. If a small amount of chromous chloride is placed in the water with the chromic chloride, solution of the chromic chloride immediately takes place and a beautiful violet solution results. Just as in chemical catalysis, the chromous chloride suffers no change whatsoever. Its powerful presence causes a release of potential energy which results in the chromic chloride passing into solution. The addition of .000025 of a gram of chromous chloride is sufficient. This is truly the magic of nature in its highest form.

The catalytic power of a catalyst is inexhaustible. It may be used over and over again, yet it remains just as potent as ever. Some catalysts exert their cryptic influence in more than one reaction. This is notably the case with platinum, which is a veritable chemical busybody. The oxides of iron are also powerful catalysts and bring about many chemical partnerships that would otherwise be impossible. That great "king of chemicals," sulphuric acid, is manufactured by a process in which catalysis plays the leading rôle. It would be quite impossible in this limited space to mention all the chemical processes of today in which catalysis is paramount. Catalysts are also busy in the various processes of nature. Fermentation is brought about by the catalytic influence of bacteria. In the human body, many catalytic agents are exerting their persuasive influences, and recent investigations seem to prove that the very problem of life itself is wrapped up in the mysteries of catalysis.

78

NEGATIVE CATALYSTS

There are certain substances which act in a manner directly opposite to that of catalysts; their mere presence, instead of producing chemical action, prevents it. Such substances are called "negative catalysts" and their potency in retarding chemical union is far greater than that of a catalyst in accelerating it. Prussic acid, carbon disulphide, phosphorus and sulphuretted hydrogen are powerful negative catalysts even in the most minute quantities. In considering these few negative catalysts, we are reminded that they are very poisonous to the human system and we ask ourselves: "Is it because they retard the important processes of catalysis that are constantly going on within the body?" Present-day scientists are inclined to answer in the affirmative.

There is a colloidal substance in the blood called enzyme. Enzyme is a potent catalyst and gives a wonderful exhibit of its ability in this respect when we place hydrogen peroxide upon an open wound in our flesh. A characteristic effervescence immediately takes place and the hydrogen peroxide is chemically decomposed into water and oxygen, by the wonderful influence of this enzyme in the blood. The enzyme is not changed in the least.

DETECTING THE PRESENCE OF CARBON DIOXIDE

The presence of carbon dioxide can easily be determined by allowing the gas to pass through a solution of lime water. When carbon dioxide passes through such a solution a white, curdy precipitate is produced which forms in clouds. This precipitate is calcium carbonate. A very simple experiment which will illustrate

79

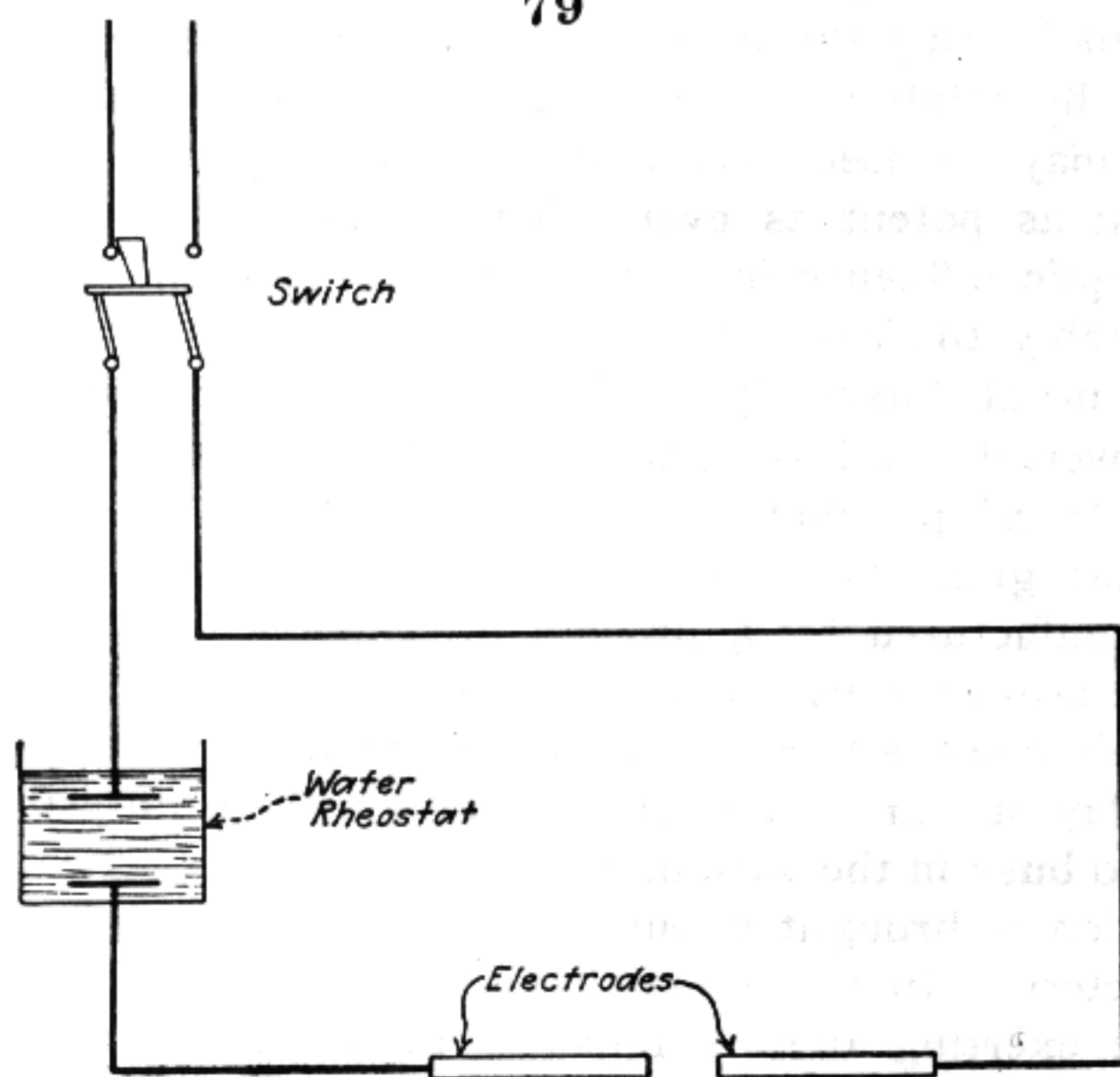

Fig. 35.—How the Electric Furnace is Connected With a Water Rheostat for Current Regulation.

this simple reaction between carbon dioxide and lime water can be made by bubbling our breath through the lime water placed in a test tube. It is a generally known fact that the exhaled breath from the human system consists of a very large percentage of carbon dioxide. The breath is blown through a small tube, the opposite end of which is immersed in the lime water.

PRODUCTION OF CALCIUM CARBONATE

Calcium carbonate can be formed in large quantities by setting up a carbon dioxide generator and allowing the gas generated to pass through a large receptacle

80

containing the solution of lime water. The setting up of a carbon dioxide generator is described in one of the later experiments in this book. Calcium carbonate produced by the reaction can easily be obtained in the solid state by evaporating the lime water solution to dryness.

ELECTROLYTIC PRODUCTION OF LEAD CARBONATE

Some very beautiful experiments in electrolysis can be produced with very little equipment in the experimental engineer's laboratory. The following lines describe the production of lead carbonate with simple apparatus. As a laboratory experiment in electrochemistry that will be of practical value as well as illustrate some of the most interesting actions of electrolysis, it is recommended to the experimenter.

Two lead electrodes, a glass vessel to hold them, and a carbon dioxide generator with a delivery tube is all the apparatus required for this beautiful experiment. The apparatus is set up as shown in the drawing, Fig. 36. A dilute solution of sulphuric acid acting on a few pieces of marble (calcium carbonate) in the gas generator will produce a sufficient quantity of carbon dioxide (CO_2) for the experiment. The electrolyte in the cell is a solution consisting of 15 grams of sodium chlorate and 5 grams of sodium carbonate. The current from a small storage battery will be sufficient to produce the electrolysis. After the electric circuit is closed, start the CO_2 generator, which delivers the gas to the negative electrode. As the CO_2 comes in contact with the cathode, a thick cloud of white lead or lead carbonate is produced and slowly precipitates to the bottom of the cell. While lead carbonate is the product obtained at the anode, sodium

81

carbonate is reproduced at the cathode. As a practical laboratory or lecture experiment in electrochemistry, this one is hard to beat. For best results, the electrolyte should be constantly agitated with a glass stirring rod while the experiment is being conducted.

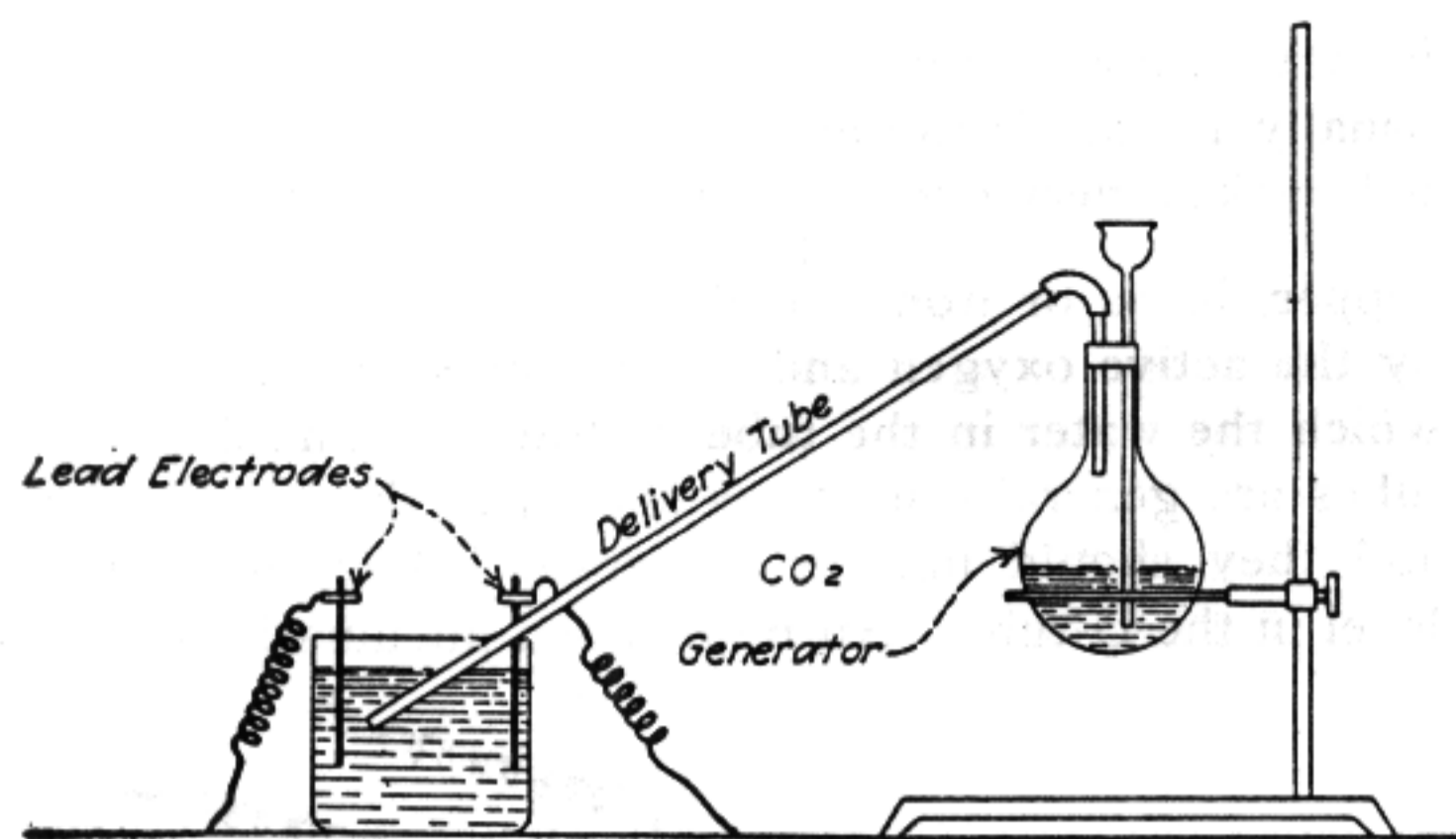

Fig. 36.—The Apparatus for the Experiment of Producing Lead Carbonate in the Laboratory.

PRODUCTION OF NITRIC ACID

The next experiment will be that of producing nitric acid. It will be understood that these experiments are outlined to give the amateur chemist a broader insight into general chemical processes rather than merely for the value of the chemicals produced. Nitric acid, of course, is very cheap and can be purchased in considerable quantities for a small amount. However, the following experiment will be interesting as well as valuable as a matter of experience.

A retort similar to that shown in Fig. 37 is used. This is an old-fashioned retort, but there will be many cases where it can be employed successfully. First, we will place some solid sodium sulphate in the retort from the opening at the top. After this, sulphuric acid is poured into the retort over the sodium sulphate. A

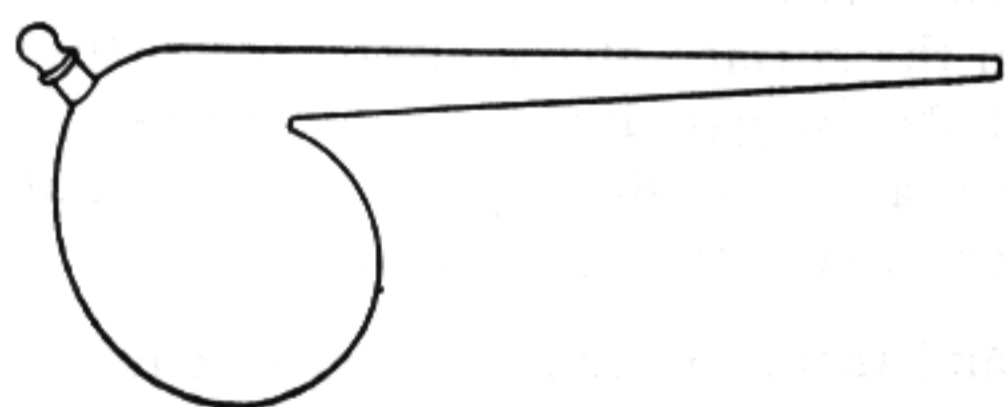

Fig. 37.—A Retort Which Finds Many Uses in the Chemical Laboratory.

test tube is placed over the free end of the retort as shown in Fig. 38 and the test tube is in turn immersed in a receptacle of cold water. With the general application of heat under the retort the following reaction will take place:



The nitric acid passes off in a vaporous state and upon reaching the cool atmosphere of the test tube it condenses to a liquid form. It will be seen that the product of the reaction, aside from nitric acid, is sodium sulphate. This can be obtained in the solid state by evaporating the solution left in the retort to

dryness.

ALLOTROPIC FORMS OF MATTER

At this point we will consider allotropic forms of matter. Carbon exists in three different states, i.e., amorphous carbon, graphite and diamond. In all of these three substances we have what the chemist recognizes as carbon with different physical proper-

83

ties. Thus, graphite is soft and unctious, while the diamond is the hardest substance known. Graphite and the diamond are the allotropic forms of carbon. There are other elements that have allotropic forms. Phosphorus is one of these.

COLLOIDAL STATE OF MATTER

The student of chemistry should not overlook that which is known as the colloidal state of matter. In the forerunning part of this book we learned something about solutions. Substances like sugar, salt, etc., are called crystalloids because they are able to pass into solution and may be again restored to their original condition by evaporating the liquid in which they are dissolved.

A colloid will not dissolve in this manner. In fact, colloids as they are generally understood, are not capable of passing into solution. The colloidal condition is a phenomena which usually associates itself with what are known as insoluble substances. If we would break the graphite tip off of our lead pencil and try to dissolve it in water, we would find that it absolutely refused to pass into solution, no matter how strongly we agitated it with every means at our disposal. If we place a little tannin in the water in which the tip of the graphite pencil was placed and removed the solution to a mortar, we would be able to make the graphite pass into a colloidal state by crushing it with a pestle. This would be a long and tedious process, however, as the graphite must be agitated considerably with the pestle before a colloidal preparation is formed. Fifteen minutes of agitation would be sufficient to bring about a "solution" of colloidal graphite. After fifteen minutes of work the dark appearing liquid in the mortar should be poured off and diluted

84

with about three times the amount of water. If the graphite passes into a colloidal condition, the resulting solution will be very dark and entirely opaque. We will find that this colloidal solution will be able to pass through filter paper as easily as a solution of sugar.

CRYSTALLOIDAL AND COLLOIDAL SOLUTION

At this point we must differentiate between a crys-

colloidal solution and a colloidal solution. Physicists believe that sugar, when dissolved in water, is reduced to a true molecular condition. This, however, is not true of colloids. The particles in the graphite solution which we just considered have been found

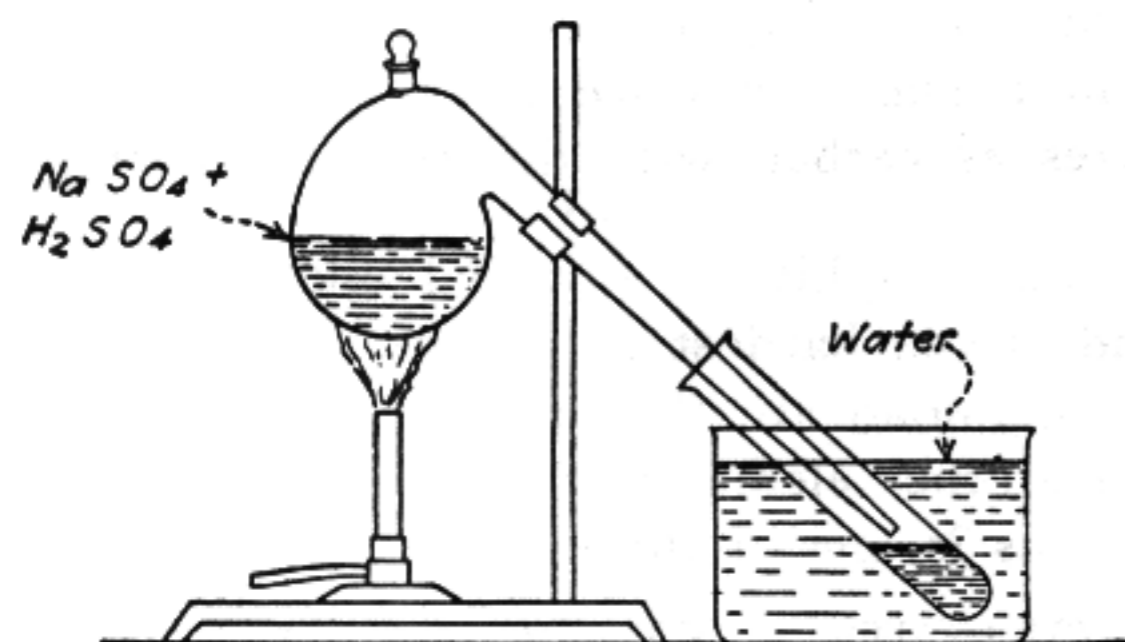

Fig. 38.—Producing Nitric Acid With Simple Apparatus as a Laboratory Experiment.

to measure about $1/250,000$ of an inch. It has been further proven that these tiny particles are held in suspension by electrical charges. It is quite reasonable to suppose that we would be able to precipitate these particles by relieving them of their electrical charges.

85

In fact, this is very easily done by putting a few drops of acid or alkaline solution in the receptacle containing the colloidal particles of graphite in suspension. Upon the addition of the acid or alkaline solution the colloidal particles of graphite immediately form larger aggregations which precipitate to the bottom of the receptacle.

Colloidal solutions of most all the metals can be obtained by forming an arc under water using an electrode of the metal of which the colloidal preparation is desired. For instance, if we desire to prepare a colloidal solution of silver we would draw an arc between two silver wires under water. It will be found difficult to maintain this subaqueous arc for any length of time. However, every time the wires are touched a small cloud of colloidal silver will be produced in the water. The water used should be as pure as possible as the colloidal particles are extremely sensitive to foreign matter.

ELECTROLYSIS OF WATER

A beautiful experiment in electrolysis is that of decomposing water into its constituent elements, hydrogen and oxygen. There is probably no experiment in the realm of electrochemistry that will do more to benefit the young scientist than this. It is an experiment that can be very easily done with simple apparatus. The set-up for the apparatus is shown in Fig. 39. A U-tube is provided with two corks and two electrodes. The electrodes should be made up of small squares of sheet platinum soldered to wires that lead to the outside of the tube. However, if platinum

is not available for this experiment, and it is not usually accessible to the amateur experimenter, carbon will make a very good substitute. Electrodes made of

86

copper, brass or iron would be readily attacked both by the active oxygen and by the sulphuric acid with which the water in the tube is diluted. The delivery tubes are generally made as shown in the illustration and they should not be immersed below the liquid level in the U-tube. An improvised pneumatic trough

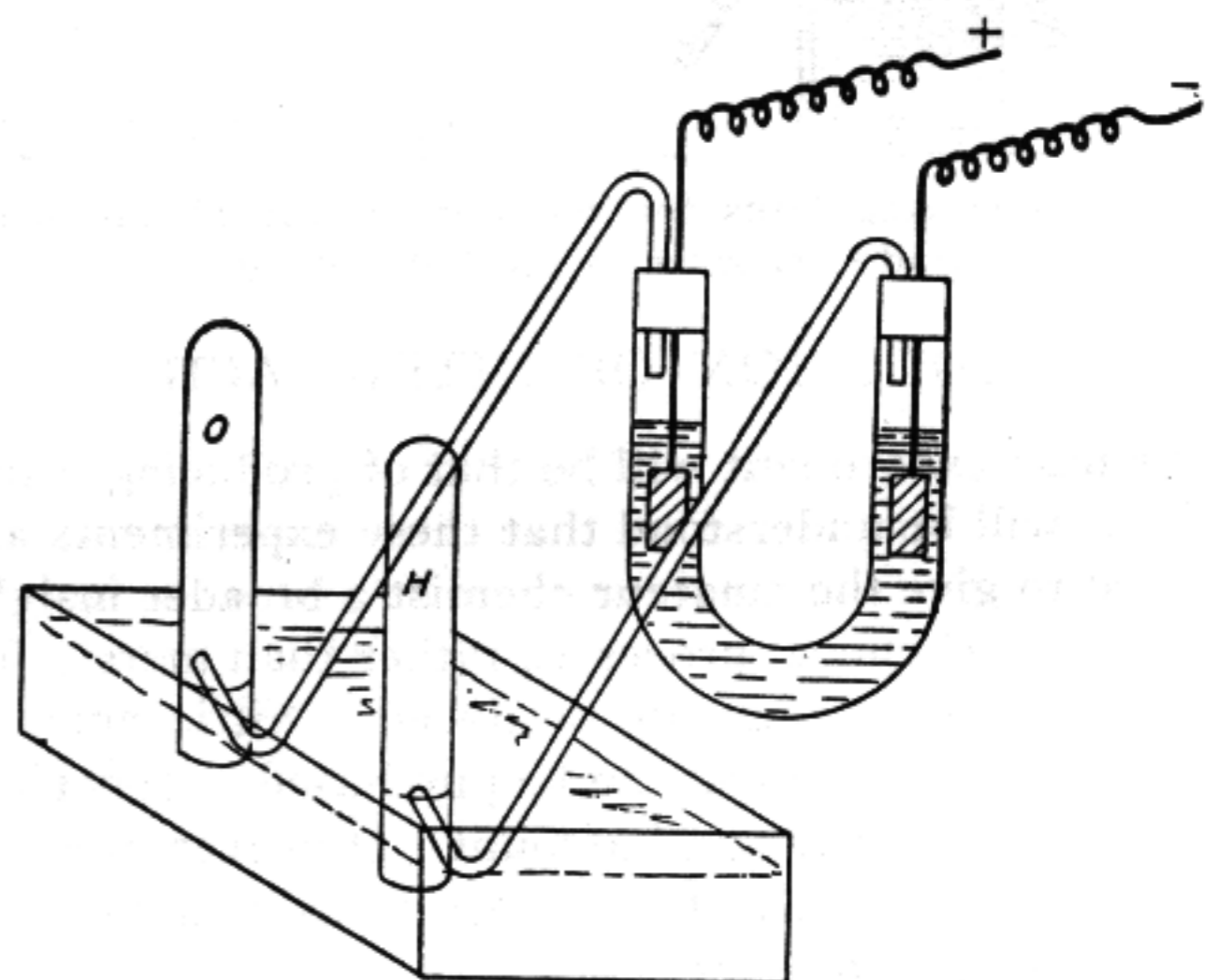

Fig. 39.—Apparatus for the Electrolysis of Water.

is used to collect the gas. Two inverted test tubes are placed over the ends of the delivery tubes as illustrated. The wires leading from the electrodes in the U-tube should be connected to a small storage battery or several dry cells. Upon the completion of the electric circuit a very energetic action will be noticed on the surface of the electrodes in the U-tube. Small bubbles of gas, hydrogen at the negative pole and oxygen at the positive pole, will accumulate and pass upward to the surface where they enter the delivery tube and thence to the inverted test tube and the pneumatic trough. As before mentioned, the water used in the U-tube should be made slightly acid by

87

used in the U-tube should be made slightly acid by

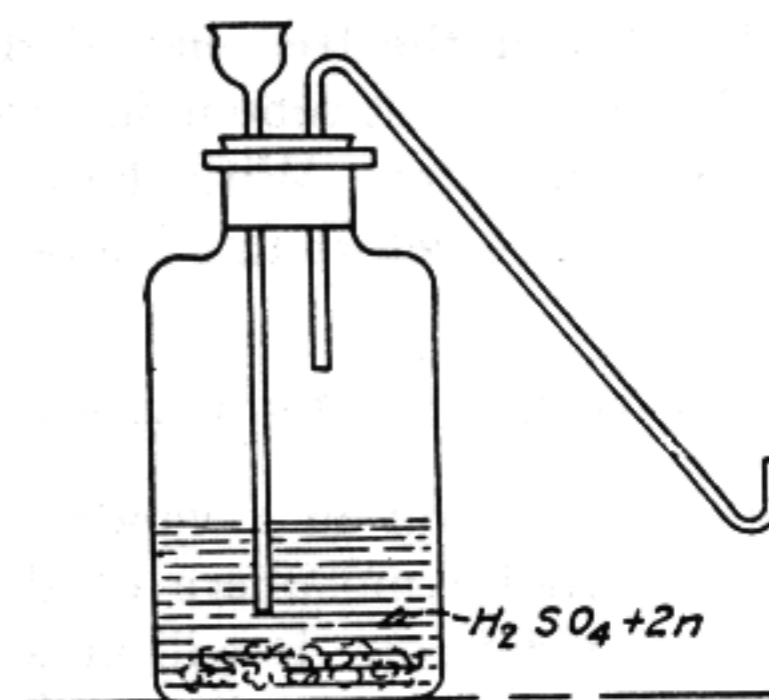

Fig. 40.—A Generator for Producing Hydrogen.

the addition of sulphuric acid. This increases the

conductivity of the water, but does not act in any other way.

GENERATION OF HYDROGEN IN QUANTITIES

Hydrogen can be produced more abundantly by allowing sulphuric acid to act upon one of the metals, preferably zinc. As mentioned in a previous part of this book, sulphuric acid, upon coming in contact with zinc, results in the production of zinc sulphide and hydrogen, according to the following formula:



The apparatus necessary for the production of hydrogen in quantities is shown in Fig. 40. It consists merely of a large mouthed bottle with a delivery tube and thistle tube placed in the cork.

88

Hydrogen can be collected by merely placing a test tube over the end of the delivery tube. It is understood that hydrogen is the lightest substance known

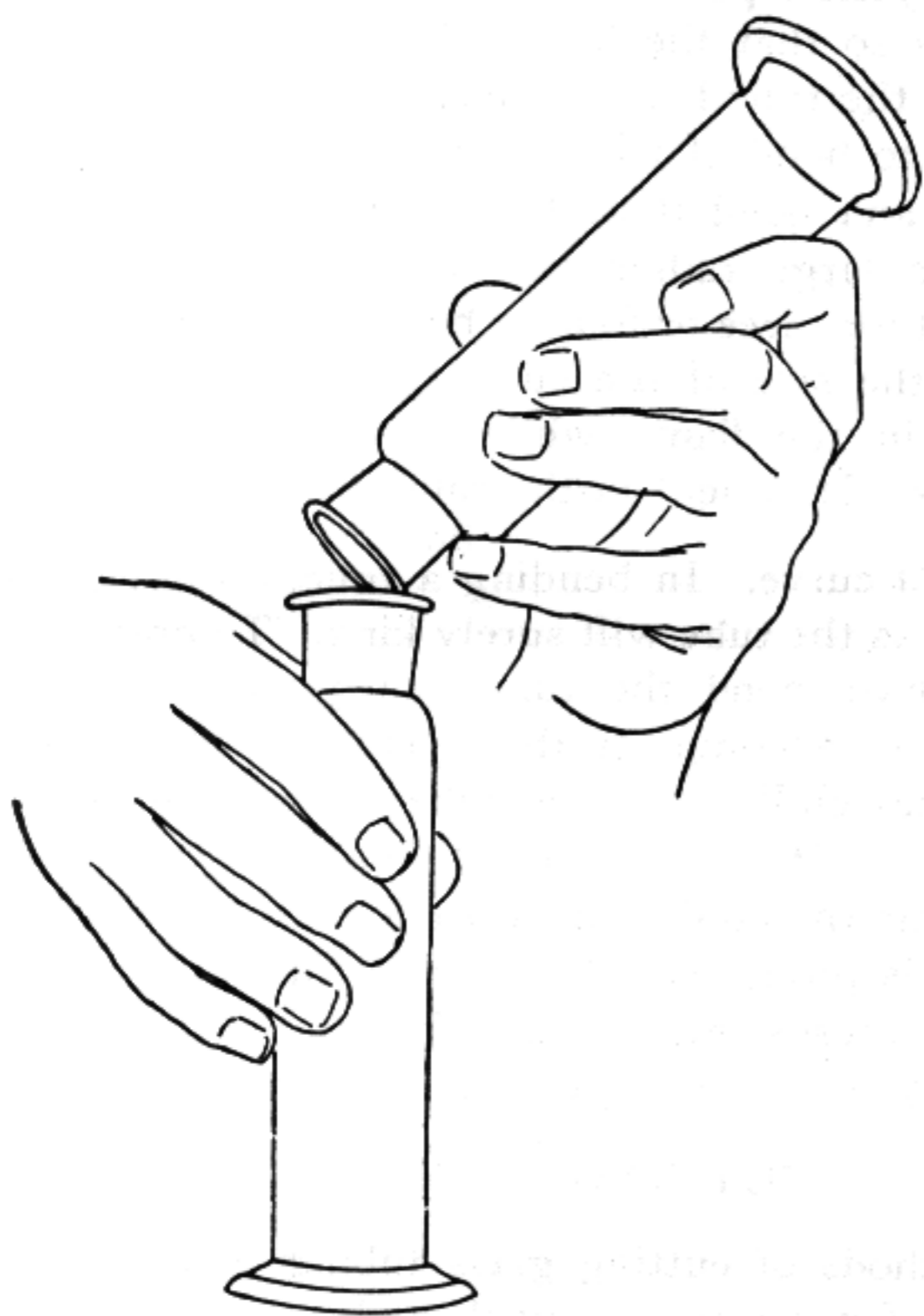

Fig. 41.—Hydrogen is Much Lighter Than Air and it Must Therefore be Poured upward.

After the test tube has been held over the delivery tube of the hydrogen generator, a match is brought to the mouth of the tube. The hydrogen will explode with a sharp report. This is owing to the fact that air or oxygen is mixed with it as it comes from the generator. If the generator is used for some time this oxygen content will be reduced and almost pure hydrogen will be available at the delivery tube. When air or oxygen is mixed with hydrogen it forms a very explosive combination. The hydrogen oxidizes or burns and, of course, the product is water. After the generator is delivering pure hydrogen a match should be introduced into the test tube containing the gas. The match will be extinguished, but the hydrogen at the entrance of the tube will be ignited and burn quietly with an almost invisible flame.

GLASS WORKING FOR AMATEUR CHEMISTS

The amateur chemist must be able to work with glass. A knowledge of the manipulation of glass in the setting-up of various combinations of apparatus in the performance of certain experiments is quite necessary.

Glass is a very difficult substance with which to work and it requires considerable care, patience and experience to handle it successfully. The experimental engineer often finds it necessary to drill, etch, cut or cement glass and, unless he is provided with proper instructions, the result of his labor is very apt to be discouraging. The various operations of glass working are described in the following paragraphs.

90

CUTTING AND BREAKING

The best and most certain method of cutting glass plates is by means of the ordinary wheel cutter and straight edge. Very little pressure should be used and the glass should be broken gently after the scratch is made. The glass should be laid on a perfectly smooth surface while it is being scratched as it is very apt to break if there are any irregularities underneath it when the pressure is applied. If a glass cutter is not at hand, the sheets may be cut with a red hot iron in the following manner: File a notch in the edge of the glass, and, starting at the notch, draw the iron slowly over the surface along the line it is desired to cut. If the iron is moved with the proper speed,

the glass being cut. The scissors should be moved very slowly and with care. Otherwise the glass will split in various directions.

It is a very difficult matter to cut off glass bottles with an ordinary cutter, and some other means must be used. One of the best and most simple methods of accomplishing this is to fill the bottle with kerosene to the height it is desired to cut it. A red hot iron is then plunged into the oil and the bottle will break evenly around the surface line of the oil, due to unequal expansion. Of all the methods of cutting off bottles, this is the most practical.

Another method of cutting a bottle or jar off with some chance of success employs a string soaked with

91

alcohol which is wound around the receptacle at a point where the cut is to be made. The string is ignited and allowed to burn out. Immediately after this, the bottle is plunged into cold water. It should then crack where the string was wound around.

DRILLING

The drilling of glass presents a very difficult problem. The softer grades may be drilled with ordinary metal drills lubricated with camphorated turpentine or a dilute solution of sulphuric acid. The drill should bear very lightly upon the glass and the lubricant should be applied very freely. A five per cent solution of commercial sulphuric acid will be found to give the best results.

The harder grades of glass may be drilled with metal drills that have been super-tempered by bringing them to a red heat and plunging them into a solution of salt water that has been previously boiled. A three-cornered file can be broken off and used to drill glass when it is placed in a chuck. The end of the file should be ground to a point on a grinding wheel.

Another rather uncertain method of making a hole in glass is to build a wall of putty where the hole is desired and fill the cup thus formed with alcohol and ignite it. After the alcohol is burned out, cold water should be splashed on the glass and the circle will drop out.

SMOOTHING ROUGH EDGES

Glass may be filed with an ordinary file using turpentine as a lubricant, but the process is slow and tedious. The only real practical method is to employ

92

a Carborundum wheel traveling at high speed. The wheel should be of very fine grit, otherwise it chips off small pieces of glass and produces a ragged edge. The proper speed of the wheel depends somewhat upon its size. Three to five-inch wheels should travel

at least 4000 r.p.m. for satisfactory results. A very good bevel can be ground on glass plates in this manner by employing a wheel of extra fine grit. In the case of using Carborundum, the grit should be about FF. The beveled edge of the glass can be polished with fine abrasive powder.

The rough edges of thin glass can be easily smoothed by "fire polishing." The edge of the glass is held in the flame of a Bunsen burner until it starts to soften. This produces a surface like the original one. In doing this, remove the glass from the flame very gradually, as it will break if cooled too suddenly.

BENDING GLASS TUBING

This is a seemingly simple operation, yet it requires no little skill to do it properly. A "fishtail" gas burner should be used to obtain the best results, although an ordinary Bunsen burner can be used. If the latter, the air supply at the base should be shut off, in order to secure a luminous flame. Place the tube in the yellow part of the flame and revolve it with the fingers so that the heat will be properly distributed. When the tube becomes heated to that point where it starts to bend of its own weight, remove it from the flame and bend it at the desired radius. If a bend with a large radius is wished, the tube should be heated for three or four inches of its length (depending upon the size of the curve) by running it back and forth in the flame while revolving it between the fingers. It is bent in the same manner as a tube with

93

a small curve. In bending a tube, do not do so with a jerk as the tube will surely kink. To obtain a graceful curve, bend the tube gently yet with sufficient speed to accomplish the operation before the glass becomes chilled. Large tubes cannot be bent in this manner. It is necessary to heat them successively, bending the tube a little each time until the desired curve is produced. The deposit of soot on the tubes, which causes them both to heat up and cool off more quickly, is easily wiped off after the tube has cooled.

CUTTING GLASS TUBING

Methods of cutting glass tubing in chemical work must of necessity be quick and simple. Small tubes may be cut by filing a notch with a three-corner file and breaking the tube at the notch by placing the thumbs at each side of it and snapping the tube off with a quick movement. Larger tubes require a scratch to be filed completely around the outside before they will break. When breaking large tubes in this manner, they should be wrapped in a towel as the hands are very apt to be lacerated, if the tubes should happen to splinter. It will be found that the foregoing methods cannot be applied to tubing with a

diameter over one inch. In cutting large tubes, two strips of wet blotting paper should be placed around the tube each side of the line that has been previously filed. The line is then followed around with either a small pointed flame or a red-hot iron.

DRAWING GLASS JETS

Glass jets are often used in chemical work and may be easily made as follows: Heat the tube in the same manner as when bending and, after taking it out of

94

the flame, pull it out gently until the diameter reaches about $\frac{1}{8}$ inch. Then allow it to cool and cut it at the desired point. After it is cut, the ends may be "fire polished" in a hot flame.

SEALING A PLATINUM WIRE IN GLASS

The only difficult thing about this operation is obtaining the platinum. The tube or glass bulb is first drawn out to a jet and the wire is then inserted. The point of the jet is revolved in the flame until the glass melts. It is then allowed to cool very slowly. It is, of course, understood that wire made of other metals cannot be sealed into glass owing to the unequal co-efficient of expansion of the two materials.

JOINING TUBING AND MAKING TEES

The operation of making a "Tee" joint requires no little patience, and the experimenter should not become discouraged if his first attempt is unsuccessful. A seven or eight inch length of the tubing is first closed at one end by heating it in a flame, rotating it until the end is completely fused together. A pointed flame is then directed on the spot where it is desired to make the joint. When this spot becomes thoroughly heated, the open end of the tube is blown through, which forces the glass to part and make a hole where the wall was heated with the pointed flame. This hole should be of about the same diameter as the tube which is to form the other part of the tube which is to be joined to the hole. During this operation, the end of the first tube should be kept closed with the finger and, when both the tubes are hot, the end of the second tube is carefully brought in contact with the edges of the hole. After the tubes

95

become slightly welded together in this position, they are taken out of the flame. The end of the first tube is then blown into, after which the joint is again placed in the flame and heated until the glass is thoroughly fused together. The "Tee" is then blown into until the point of junction entirely disappears. The superfluous tubing is then cut off.

Tubes are joined together in much the same manner. If it is desired to join a large tube to a small one,

the diameter of the large tube is first reduced by drawing the end into a jet. The ends of the tubes are then heated and joined. The junction is fashioned by blowing into the end of the tube.

SPREADING THE ENDS OF TUBING

Many times use is found for a small glass tube with a large opening in one end. The end of a small glass tube can be spread in the following manner. Take a piece of iron wire and smear it over with a thin film of vaseline at the end. Heat the end of the wire and the tube in the flame and when the glass becomes sufficiently soft, insert the hot iron wire in the end and rotate the tube slowly. Take care that the tube does not become too hot.

GLASS SPIRAL TUBES

Spirals of glass tubing are often used in chemical experiments. The operation in making these spirals is not so difficult as it may seem at first thought. It will be necessary to make a winding jig. In winding the hot tubing on the form or jig it will be necessary to have an assistant turn the windlass. In starting the spiral, the tube is first heated and bent at right angles. It is then fastened to the pipe by means of a few turns

96

of wire. The blow-pipe is then lighted and the flame directed on the glass tube. As the glass becomes heated to the proper point, the windlass is slowly turned. It should not be turned either too fast or too slow, but just at the right speed. If the tube is heated too much, it will flatten out as it is wound on the pipe. If it is not heated enough, it will crack. It is advisable to use tubing with a thick wall in making glass spirals, as it is not so liable to collapse.

INDEX

	PAGE
A	
Acids	27
Alcohol Burner	44
Allotropic Forms of Matter	82
Atomic Weight	8
Atoms	10
B	
Bases	27
Beakers	58
Bending Glass Tubing	92
Blue Litmus Paper	57
Breaking Glass Tubing	65
Brush For Cleaning Test Tubes	59
C	
Catalytic Agents	65
Chemical Activity	15
Chemical Balance	46
Chemical Formulas	19
Chemical Symbols	9

	PAGE		PAGE
Chemical Thermometer	56	J	
Chemicals for the Laboratory	62	Joining Glass Tubes	95
Colloidal Solutions	84	L	
Colloidal State	83	Laboratory Clamps	61
Compounds	7	Law of Combining Weights	24
Construction of a Ring Stand	49	Law of Definite Proportions	22
Construction of a Small Electric Furnace	71	List of Acids	27
Construction of Chemical Balance	46	List of Bases	29
Construction of Shelves for Laboratory	40	M	
Construction of Test Tube Racks	49	Making Glass Tees	94
Crystalloidal Solutions	84	Method of Obtaining Heat	43
Cutting and Breaking Glass	90	Molecules	10
D		N	
Detecting the Presence of Carbon Dioxide	78	Negative Catalysts	78
Different Kinds of Chemical Compounds	23	Neutralization	68
Different Kinds of Chemical Reactions	23	Neutral Substances	28
Distillation of Water	69	Non-Electrolytes	34
Drawing Glass Jets	93	O	
Drilling Glass	91	Organic Chemistry	30
E		P	
Electrochemistry	30	Physical and Chemical Changes	21
Electrolysis of Water	85	Pinch-cocks	58
Electrolysis of Zinc Chloride	38	Pipettes	57
Electrolytes	34	Pneumatic Trough	64
Electrolytic Production of Lead Carbonate	80	Preparation of Metallic Zinc	38
Electrolytic Production of Sodium	37	Preparation of Oxygen	64
Electrons	12	Production of Calcium Carbonate	79
Elements	7	Production of Chlorine	67
Erlenmeyer Flasks	59	Production of Nitric Acid	81
Evaporating Dishes	53	R	
Experiments in Catalysis	75	Red Litmus Paper	57
Experiments in Electrochemistry	37	Retorts	82
Experiments with Chlorine	68	S	
Experiments with Oxygen	65	Sealing Platinum Wire in Glass	94
F		Small Electric Furnace	71
Filter Paper	55	Smoothing Rough Edges of Glass	91
Fire and Chemical Proof Paint	41	Solubility	26
Fire Clay Crucibles	54	Solutions	25
Fractional Distillation	70	Speed of Chemical Reactions	20
Furnace Connections	74	Spreading the Tubing Ends of Glass	95
G		Structure of the Atom Helium	16
Generator of Hydrogen	87	T	
Glass Working	89	Test Tubes	53
Graduated Cylinder	55	Theory of Electrolytes	31
H		Thermit	70
Hood to Carry Away Gases	42	U	
How Electrons Form Atoms	12	Use for Filtering Paper	55
Hydrogen Sulphate Generator	50	Use of Thistle Tubes	59
I		W	
Inorganic Chemistry	30	Wash Bottles	60
		Wire Clip for Holding Test Tubes	53