

A
TREATISE ON CHEMISTRY.

BY
H. E. ROSCOE F.R.S. AND C. SCHORLEMMER F.R.S.

PROFESSORS OF CHEMISTRY IN OWENS COLLEGE, MANCHESTER.

VOLUME II.—METALS.

PART I.

"Chymia, alias Alchemia et Spagirica, est ars corpora vel mixta, vel composita, vel aggregata etiam in principia sua resolvendi, aut ex principis in talia combinandi."—STADL, 1723.

SECOND EDITION.

London:
MACMILLAN AND CO.
1879.

The Right of Translation and Reproduction is Reserved.

LONDON:
K. CLAY, SONS, AND TAYLOR,
BREAD STREET HILL, E.C.

CONTENTS.

	PAGE
THE METALS	3
METALLIC ALLOYS	6
AMALGAMS	9
GENERAL PROPERTIES OF THE METALS	11
Specific Gravity	11
Melting-point	12
Crystalline Form	12
Fracture	13
Conductive Power for Heat and Electricity	13
Atomic Heat	14
Molecular Heat of Compounds	20
CLASSIFICATION OF METALS	22
Quantivalence of the Metals	27
GENERAL PROPERTIES OF THE OXIDES AND HYDROXIDES	30
GENERAL PROPERTIES OF THE ACIDS	32
CONSTITUTION OF SALTS	34
SOLUBILITY OF SALTS	43
GENERAL PROPERTIES OF SALTS	48
METALS OF THE ALKALI GROUP	54
POTASSIUM	55
Potassium and Hydrogen	61
Potassium and Oxygen	62
Salts of Potassium	66
Potassium and Sulphur	97
Potassium and Nitrogen	100
Detection and Estimation of Potassium	101
SODIUM	102
Sodium and Hydrogen	107
Sodium and Oxygen	107
Salts of Sodium	110
The Alkali Manufacture	132
Sodium and Sulphur	154
Sodium and Nitrogen	154
Detection and Estimation of Sodium	155

	PAGE
LITHIUM	157
Lithium and Oxygen	160
Salts of Lithium	161
Detection and Estimation of Lithium	163
RUBIDIUM	164
Salts of Rubidium	168
Detection and Estimation of Rubidium	169
CÆSIUM	169
Salts of Cæsium	171
Detection and Estimation of Cæsium	171
AMMONIUM SALTS	173
Ammonium and Sulphur	184
Oxy-ammonium Compounds	185
METALS OF THE ALKALINE EARTHS	187
CALCIUM	187
Calcium and Oxygen	189
Salts of Calcium	191
Manufacture of Bleaching Powder	194
Mortars and Cements	209
Calcium and Sulphur	210
Detection and Estimation of Calcium	211
STRONTIUM	213
Strontium and Oxygen	214
Salts of Strontium	215
Detection and Estimation of Strontium	217
BARIUM	218
Barium and Oxygen	220
Salts of Barium	222
Barium and Sulphur	227
Detection and Estimation of Barium	229
METALS OF THE MAGNESIUM GROUP	231
BERYLLIUM	231
Beryllium and Oxygen	233
Salts of Beryllium	234
Detection and Estimation of Beryllium	235
MAGNESIUM	236
Magnesium and Oxygen	240
Salts of Magnesium	241
Magnesium and Sulphur	248
Magnesium and Nitrogen	248
Detection and Estimation of Magnesium	249
ZINC	250
Smelting of Zinc	253
Zinc and Oxygen	258
Salts of Zinc	259
Detection and Estimation of Zinc	264

CONTENTS

vii

	PAGE
CADMIUM	265
Salts of Cadmium	267
Detection and Estimation of Cadmium	269
 METALS OF THE LEAD GROUP	270
 LEAD	270
Smelting of Lead	272
Lead and Oxygen	281
Salts of Lead	285
Poisonous Action of Lead Salts	294
Action of Lead upon Water	295
Lead and Sulphur	296
Detection and Estimation of Lead	298
 THALLIUM	300
Thallium and Oxygen	301
Thallic Compounds	303
Thallic Compounds	306
Detection and Estimation of Thallium	307
 METALS OF THE COPPER GROUP	309
 COPPER	309
Smelting of Copper	310
Electrotyping Processes	324
Copper and Hydrogen	327
Copper and Oxygen	328
Salts of Copper	331
Cuprous Salts	331
Cupric Salts	334
Copper and Sulphur	343
Copper and Nitrogen	344
Copper and Phosphorus	344
Copper and Arsenic	345
Detection and Estimation of Copper	345
 SILVER	347
Metallurgy of Silver	347
Silvering and Plating	361
Alloys of Silver	365
Silver and Oxygen	367
Salts of Silver	369
Silver and Sulphur	380
Action of Light on Silver Salts	380
Detection and Estimation of Silver	384
 MERCURY	387
Alloys of Mercury	394
Mercury and Oxygen	396
Salts of Mercury	397
Mercurous Salts	399
Mercuric Salts	402

	PAGE
Mercury and Sulphur	409
Mercury and Nitrogen	412
Mercurous Ammonium Compounds	413
Mercuric Ammonium Compounds	413
Mercury and Phosphorus	416
Detection and Estimation of Mercury	416
METALS OF THE CERIUM GROUP	418
YTTRIUM	424
Salts of Yttrium	424
Detection and Estimation of Yttrium	425
LANTHANUM	425
Salts of Lanthanum	426
Detection and Estimation of Lanthanum	427
CERIUM	427
Cerium and Oxygen	428
Salts of Cerium	429
Cerous Salts	429
Ceric Salts	430
Detection and Estimation of Cerium	431
DIIDYMIUM	431
Salts of Didymium	432
Detection and Estimation of Didymium	432
TERBIUM	433
ERBIUM	434
METALS OF THE ALUMINIUM GROUP	436
Aluminium	436
Alloys of Aluminium	441
Aluminium and Oxygen	442
Aluminates	445
Salts of Aluminium	446
Alums	450
Ultramarine	458
Detection and Estimation of Aluminium	460
Glass, Porcelain, and Earthenware	461
Composition of Glass	462
Manufacture of Glass	471
Opaque and Coloured Glass	481
Pottery, Porcelain, and Earthenware	490
INDIUM	499
Salts of Indium	500
Detection and Estimation of Indium	501
GALLIUM	502
Salts of Gallium	504

ERRATA IN VOL. II., PART I.

Page	17,	line 28	from top,	for "Wolfram" read "Tungsten."
"	22,	" 23	" "	for "glucinum" read "beryllium," (twice).
"	23,	" 3	" "	for "Lanthanium" read "Lanthanum."
"	26,	" 10	" "	for "with" read "into."
"	26,	" 22	" "	for "silver" read "mercury."
"	27,	since line 11,	<i>et seq.</i>	was written the vapour density of lead chloride has been determined and found to agree with the formula $PbCl_2$. The argument therefore does not apply to this particular compound.
"	23,	line 25	from top,	for " C_6H_6 ," read " C_6Cl_6 ."
"	28,	" 34	" "	for "Tetrachlorethane" read "Tetrachlorethene."
"	29,	" 8	" "	for "tetrachlorethane," read "tetrachlorethene."
"	38,	" 12	" "	for " H_2SO_4 ," read " H_2SO_3 ."
"	38,	" 13	" "	for " Na_2SO_4 ," read " Na_2SO_3 ."
"	41,	" 19	" "	after equation, add " + H_2O ."
"	65,	" 18	" "	for "1.508," read "1.058."
"	70,	" 12	bottom,	after " $3Cl_2$," for "+," read " =."
"	70,	" 6	" "	for "one-fifth," read "one-sixth."
"	73,	" 9	top,	after "Perchlorate," insert " $KClO_4$."
"	81,	" 13	" "	for "Græcus," read "Græcna."
"	91,	" 12	bottom	for "percipitato," read "precipitate."
"	97,	" 13	top,	for " $2HO$," read " $2H_2O$."
"	102,	" 12	" "	for "74.71," read "74.41."
"	102,	" 6	bottom,	for "22.29," read "22.99."
"	103,	" 2	" "	for "compound says" read "compounds are."
"	109,	" 21	" "	for " N_2O_2 ," read " Na_2O_3 ."
"	110,	" 11	" "	for "mountain limestone," read "keuper (triassic) beds."
"	115,	" 12	" "	for "potassium," read "sodium."
"	121,	" 9	top,	for " Na_3PO_4 ," read " Na_2PO_3 ."
"	121,	" 12	" "	for " H_2O ," read " $4H_2O$."
"	121,	" 6	bottom,	for " $3Na_2NO_3$," read " $3NaNO_3$."
"	121,	" 5	" "	for "Di-hydrogen Sodium," read "Hydrogen Di-Sodium."
"	144,	" 2	top,	for "28," read "29."
"	144,	" 3	" "	for "29, 30, and 31," read "30, 31, and 32."
"	172,	" 14	bottom,	for " $CsSnCl_6$," read " Cs_2SnCl_6 ."
"	202,	" 7	top,	for "potassium," read "sodium."
"	222,	" 14	bottom,	for " $2CO_2$," read " $2CO$."
"	222,	" 15	" "	for "dioxide," read "monoxide."
"	231,	" 16	" "	for "9," read "9.2."
"	237,	" 15	top,	for " $MgCl$," read " $MgCl_2$."
"	307,	" 8	" "	for " $Tl_2(SO_4)_3 + H_2O$," read " $Tl_2(SO_4)_2 + 7H_2O$."
"	340,	" 1	" "	for " $2NH_3$," read " $2NH_4$."
"	341,	" 6	bottom,	for " $\chi\pi\pi\sigma\sigma$," read " $\chi\pi\pi\sigma\sigma$."
"	370,	" 17	top,	for "260," read "450."
"	392,	" 1	bottom,	for "14.931," read "14.1932 (Mallet)."
"	436,	" 7	" "	for "corpores," read "corpora."
"	504,	" 6	top,	for "combines," read "combines."

CHEMISTRY.

CHEMISTRY.

THE METALS.

THE metals gold, silver, copper, iron, tin, and lead were known to the ancients. We find them mentioned in the writings of the Old Testament, as well as in those of the early Greek authors. The name of mercury is first found in the writings of Theophrastus; but the existence of the remaining metals only became known in comparatively recent times. Antimony appears to have been obtained by Basil Valentine, and zinc and bismuth were both described by the same alchemist, although their properties did not become generally known until the sixteenth century.

An historical notice concerning each metal will be found under its own heading. We have here simply to consider the progress of our knowledge concerning the properties of the metals as a class.

Geber is the first author in whose writings we find a distinct definition of the word metal: "*Metallum est corpus miscibile, fusibile, et sub malleo ex omni dimensione extendibile.*" According to this definition mercury is not included amongst the metals. Geber likewise distinguished gold and silver as the noble metals, because they do not undergo any change in the furnace, whereas the others were termed base metals. This definition was accepted throughout the whole of the middle ages, so that when the brittle metals antimony, bismuth, and zinc came to be well known, they were classed as bastard or semi-metals. Thus for instance, Paracelsus says: "*Zinc, which is a metal and yet no metal, and bismuth and the like being partly malleable are bastards of the metals; that is*

substances which somewhat resemble them." Opinion was divided respecting the position of mercury, until its solidification by extreme cold and its malleability in this condition had been observed. From this time forward it was universally admitted to be a metal.

As chemistry progressed it became evident that the division between metals proper and semi-metals could not be maintained, and the followers of Lavoisier altogether ignored this distinction, and acknowledged the existence of seventeen metals. Shortly afterwards Davy's discovery of the alkali metals again enlarged our views concerning the nature of metals. These substances, inasmuch as they are lighter than water, were at first not considered to be metals proper, and Erman and Simon,¹ in 1808, suggested that sodium and potassium were not true metals, but rather metal-like bodies, and proposed for them the term "metalloid" (*μέταλλον* a metal, *είδος* similar). This name was, however, not long employed in this sense, but was made use of by Berzelius, in the year 1811, to distinguish the class of non-metallic elements from the metals, and although badly chosen, the word is still frequently used to designate the former of two groups of elements.

2 As we are now acquainted with sixty-four elements, and as the number increases from year to year, this distinction between metals and non-metals is preserved simply for the sake of convenience, and not as one founded upon any real or essential difference of properties of these two classes of elements.

At one time, when only few metals were known, they could be readily distinguished from the non-metals, especially by their high specific gravity and their peculiar metallic lustre. As soon, however, as the alkali metals were discovered, the important property of high specific gravity ceased to be characteristic of the metals, and when tellurium became known, which—although by its chemical properties it is closely allied to sulphur—possesses a bright silver-like lustre, the second distinction ceased to be universally applicable. In the same way, other properties which were at one time believed to be characteristic of metals have, with the progress of knowledge, been found no longer to be essential. Thus, opacity was long deemed a necessary property of a metal, but now we know that in very thin layers metals are transparent. Gold-leaf transmits green light, and silver-leaf allows chiefly the blue rays to pass.

¹ Gilbert's *Annalen*, xxviii. 347.

The elements of the nitrogen group exhibit in a striking manner this gradual transition from a distinctly non-metallic to a distinctly metallic element. Thus whilst nitrogen itself is undoubtedly a non-metallic body, phosphorus in certain of its allotropic modifications closely approaches the metals. Indeed one of these modifications, by reason of its physical peculiarities, is termed metallic phosphorus. Arsenic, the third member of the nitrogen family of elements, was formerly classed as a semi-metal. At a later period it was considered to be a metal proper, and even now some chemists rank it amongst the metals, whilst others, looking to its striking similarity with phosphorus, place it amongst the non-metals. Antimony and bismuth are elements which belong to this same group, and these substances are usually considered to be metals from their close analogy to other distinctly metallic substances. In this case it will be noticed that the members of this group of elements approach more and more closely to a true metal as their atomic weights increase. The same peculiarity is observed in other groups. The metals titanium and zirconium are, on the one hand, closely connected with non-metallic silicon, whilst, on the other, they exhibit the most marked analogies with tin, and are usually classed, accordingly, amongst the metals. We must, however, be careful not to draw the conclusion that as a rule the elements which possess the highest atomic weights are metals, and those which possess the lowest are non-metals. Lithium, which next to hydrogen possesses the smallest atomic weight, is a well characterized metal, and hydrogen itself exhibits in its chemical relations far more analogy with the metals than with the non-metals.

Although the division into metals and non-metals is thus seen to be one which does not admit of exact definition, it is not the less true that the metals as a class do possess certain generic properties which the non-metals either do not possess at all or exhibit only in a very slight degree. Amongst these properties that of metallic lustre may especially be mentioned. This property is characteristic of all metals, and if it is not noticeable when the metals are in the state of fine division, in which case they frequently appear in the form of black powders, it can readily be observed when the powder is rubbed with a hard body.

Another generic difference which may be noticed is that whilst many, or even all of the oxides of the non-metals belong,

as a rule, to the class of acid-forming oxides, it is only the highest oxides of certain of the metals which are capable of acting in this way; the greater part of the metallic oxides being basic oxides,

ALLOYS.

3 Another proof of the close resemblance existing amongst the metals is to be found in the peculiar compounds or mixtures which different metals form with one another, and to which the name of *alloy* is given. Amongst chemical compounds in general, those are found to be most stable and to show the greatest amount of chemical individuality whose constituents are the most diverse. In the case of the alloys, however, the essential properties of the metals are uniformly reproduced. Thus, they all possess metallic lustre; they conduct heat and electricity well; even when they assume distinct crystalline form and contain their constituents in the proportion of their combining weights. Hence these alloys are distinguished from the compounds which the metals form with such elements as oxygen, sulphur, and chlorine, in which the general properties of the metal have undergone a complete change. In the same way, we find that the metals whose chemical properties are the most dissimilar form alloys which bear the closest resemblance to distinct chemical compounds. This class of alloys is difficult to prepare, inasmuch as the bodies possess the power of dissolving an excess of one or other constituent when in the fused state.

Many metals can be fused together in all proportions; others, again, cannot be made thus to unite. To the first of these groups silver and lead belong and to the second, zinc and lead. Lead can only retain 1.6 per cent. of zinc, and zinc can only absorb 1.2 of lead.¹

According to Matthiessen,² the metals may be divided into two classes so far as their power of forming alloys is concerned. The first of these classes includes the metals lead, tin, zinc, and cadmium. These metals impart to their alloys their own physical properties in the proportions in which they themselves are contained in the alloy. The second class contains almost all the other metals. They do not impart to their alloys their own

¹ Matthiessen and von Bose, *Proc. Roy. Soc.* xi. 430.

² *Journ. Chem. Soc.* xx. 201.

physical properties in the proportion in which they themselves are present in the alloy. The alloys themselves may be divided into three groups :—

- (1) Those formed by the metals of the 1st class only.
- (2) Those formed by the metals of the 2nd class only.
- (3) Those which contain metals of both classes.

When two metals are melted together to form an alloy, an evolution of heat sometimes occurs. Certain of the physical properties of the metal are always preserved in the alloy. Thus, the specific heat and the co-efficient of expansion of the alloy are always the means of those of its component metals. In other properties a variation takes place. Thus whilst the specific gravity of the alloys of the first class is the mean of that of their constituent metals, that of the alloys of the second class is always either greater or less than the mean specific gravity of the constituents. All alloys, with the exception of that formed by the union of one part of potassium to three of sodium, are solid at the ordinary temperature.

4 The melting point of an alloy is usually lower than that of the metals which compose it. This is well seen in the case of ordinary plumbers' solder, consisting of tin and lead, which melts more easily than either of the metals composing it. This fact was known so long ago as the time of Pliny, for he states that tin cannot be soldered without lead, nor lead without tin, and that lead tubes are soldered with a mixture of one part of tin and two parts of lead, a mixture which is used at the present day. Homburg, in 1669, recommended an alloy of equal parts of tin, lead, and bismuth for sealing up anatomical preparations ; and in 1772¹ Valentine Rose the elder discovered the well-known fusible metal which bears his name. This consists of one part of tin, one part of lead, and two parts of bismuth. It melts at 95° to 98°, the lowest melting point of its constituents being that of tin, viz., 235°. Another alloy, consisting of eight parts of lead, fifteen of bismuth, four of tin, and three of cadmium, softens at a temperature of 60° and is perfectly liquid at 65°, the melting points of its constituents being—tin 235°, bismuth 270°, cadmium 315°, and lead 334°. ² This lowering of the melting point is not confined merely to alloys, but occurs in the case of fused mixtures of many salts. Thus, mixtures of the carbonates or chlorides of potassium and sodium fuse at a much

¹ *Stralsund Magazin*, 1772, 2.

² Lipowitz, *Dtngl. Poly. Journ.* clviii. 376.

lower temperature than any of the salts separately. It would thus appear that we cannot argue from this property as to the chemical combination of the metals in the alloy, for we can scarcely assume that a combination of the above-named salts occurs when they are fused together.

The conducting power for electricity of the alloys of the first class is exactly proportional to the relative volumes of the component metals. This is not the case with the alloys of the second class. Wiedemann and Franz have shown that the conducting power for heat of metals and alloys is identical with their conducting power for electricity.

In their other physical properties the two classes of metals differ very widely when alloyed. Thus a metal of the second class when alloyed with a small quantity of one of the first class has its coefficient of elasticity much increased. A bar of tin, copper, or zinc emits a dull sound when struck, but if copper be alloyed with a small quantity of tin we obtain bell-metal, valuable for its sonorous properties. The same fact is observed when the elasticity of coils of metal wires is compared with that of coils made of alloys. Thus coils of copper, silver, gold, and platinum wire are lengthened to a straight wire by weights by which a coil of gun-metal or brass will scarcely be altered in shape.

Many of the alloys are largely employed in the arts and manufactures, as they possess properties which are wanting in the single metals. Thus pure gold and silver are too soft to be minted, but the addition of a small proportion of copper gives them the necessary hardness. Pure copper is so soft and tenacious that it is not suitable for use in the lathe. The addition of half its weight of zinc produces an alloy which is hard, and yet possesses the necessary brittleness to enable it to be readily turned. Gun-metal is a very tenacious and hard alloy, containing nine parts of copper to one part of tin. A still harder alloy is bell-metal, consisting of two parts of tin to eight parts of copper. The more tin such an alloy contains the lighter is its colour. Speculum metal possesses a white colour, is capable of receiving a very high polish, and is, therefore, used for the specula of telescopes. It contains one part of tin to two parts of copper. Type-metal is made up of one part of antimony to four parts of lead. This alloy is hard, easily fusible, not brittle, and expands at the moment of solidification—properties which are possessed by no other single metal or alloy. Many alloys

can be obtained in well-defined crystalline forms, but even this usual test of the existence of a definite chemical compound cannot be relied upon in the case of alloys, as it has been shown by Cooke¹ that alloys of zinc and antimony, varying in composition from 43 to 64 per cent of zinc, all crystallise in the same form, although in a different form from other alloys of these two metals. In the same way Matthiessen and von Bose² have observed, in the case of the gold-tin alloys, that well-defined crystals are not limited to definite proportions of the two metals, but are common to all alloys of these metals containing from 27 to 43 per cent. of gold. Storer³ has likewise proved that all the copper-zinc alloys crystallize in the same form.

A remarkable fact with regard to the solubility of the alloys in acids must here be mentioned. If an alloy of platinum and silver be boiled with nitric acid it is completely dissolved: whereas platinum when unalloyed is quite insoluble in this acid. On the other hand, silver by itself readily dissolves in nitric acid, but it does not do so when it is alloyed with much gold, the whole of the silver being soluble only when its quantity is at least double that of the gold. It was formerly believed that in order to separate the whole of the silver only one quarter of the alloy must consist of gold, whence the term *quartation*, which is still used for the separation of these metals.

AMALGAMS.

5 Amalgams are compounds or mixtures of metals with mercury. The name is first found in the writings of Thomas Aquinas; and Libavius explains the meaning of the word as follows:—"Amalgama corruptum vocabulum esse ex Graeco *μάλανμα* non dubitant." It is perhaps more probable that the word is derived from the Arabic, as the form *algamala* also occurs in the writings of alchemists.

The ancients were acquainted with the fact that mercury can combine with the metals, and they employed the property for the extraction of gold from its ores; Vitruvius even gives a method for extracting the gold by means of mercury from vestments which have been embroidered with gold thread. Geber speaks more distinctly respecting the compounds of the metals with mercury, for we find in his work, *Summa perfec-*

¹ *Mém. Amer. Acad. N. S.* v. 337.

² *Proc. Roy. Soc.* xi. 433.

³ *Boston Amer. Acad.* viii. 27.

tionis magisterii, the following words, "Mercurius adhæret tribus mineralibus de facili, Saturno (lead) scilicet, Jovi (tin) et Soli (gold). Lunæ (silver), autem magis difficulter. Veneri (copper) difficilium quam Lunæ. Marti (iron), autem nullo modo, nisi per artificium. Est enim amicabile et metallis placabilis. Solvuntur Jupiter et Saturnus, Luna et Venus ab eo." Thus it is clear that Geber knew that, with the exception of iron, mercury combines directly with all the metals. The problem of the preparation of iron amalgam was one to which the alchemists paid great attention as, according to Geber, it was no easy matter. Libavius gives the first hints toward the solution of this problem, as he says that the common metals require to be purified by corrosive action before they can be made to unite with mercury.

Amalgams are usually obtained by the direct union of the metal with mercury. In this case diminution of temperature is not unfrequently noticed; thus, when tin is dissolved in mercury. Sometimes, on the other hand, heat is evolved, as when the alkali-metals are amalgamated. Amalgams are also produced by the addition of mercury to a solution of a metallic salt; thus if this metal be added to a solution of silver nitrate, the amalgam separates out in splendid crystals—the *Arbor Dianæ* of the ancients. Another mode of obtaining an amalgam is to place the metal in a solution of mercuric nitrate, or together with mercury and a dilute acid; and lastly, amalgams are formed by the action of a weak galvanic current upon a solution of salt into which a globule of mercury has been poured, the zinc pole dipping into the globule of mercury.

The amalgams containing a large quantity of mercury are often liquid, whilst those which contain less are frequently found to crystallize. When heated above the boiling point of mercury a certain number of the amalgams retain a certain proportion of mercury. Thus silver amalgam when heated to 450° leaves a compound which still contains 12 per cent. of mercury; and a gold amalgam treated in the same way leaves a residue containing 10 per cent. of mercury.¹ Similar results are obtained with copper, sodium, and potassium, the composition of the residues corresponding to the following formulæ:—



The two last are crystalline, and the sodium compound takes

¹ De Souza, *Ber. Deutsch. Chem. Ges.* viii 1616; *ibid* ix. 1050

fire on exposure to the air. The metals lead, tin, cadmium, and bismuth do not retain mercury at a temperature of 450°.

Regarded as compounds the amalgams are very unstable, for Joule¹ has shown that they can be decomposed by subjecting them to a very high pressure.

Many amalgams are used in the arts. Tin amalgam is employed in the silvering of mirrors, gold and silver amalgams in the processes of gilding and silvering in the dry way; zinc and tin amalgam for coating the rubbers of electrical machines, and cadmium amalgam for stopping teeth.

SPECIFIC GRAVITY OF THE METALS.

6 The specific gravities of the various metals differ considerably. The following table contains the best determinations of specific gravity of some of the most important of the metals:—

	Spec. Grav.	Temp.	Observer.
Osmium . . .	22·477	—	Deville and Debray.
Iridium . . .	22·40	—	" "
Platinum . . .	21·50	—	" "
Gold	19·265	13°	Matthiessen.
Mercury . . .	13·596	0°	Kopp.
Rhodium . . .	12·1	—	Deville and Debray.
Thallium . . .	11·8	—	Crookes.
Palladium . . .	11·4	22°5	Deville and Debray.
Lead	11·367	14°	Karsten.
Silver	10·468	13°	Holzmann.
Bismuth . . .	9·823	12°	"
Copper	8·952	—	Schröder.
Cadmium . . .	8·655	11°	Matthiessen.
Iron	7·79	—	Karsten.
Tin	7·294	13°	Matthiessen.
Zinc	6·915	—	Karsten.
Antimony . . .	6·713	14°	Matthiessen.
Aluminium . . .	2·67	—	Wöhler.
Magnesium . . .	1·743	5°	Bunsen.
Calcium	1·578	—	Bunsen and Matthiessen.
Rubidium . . .	1·516	—	Bunsen.
Sodium	0·974	10°	Baumhauer.
Potassium . . .	0·865	—	Gay-Lussac and Thénard.
Lithium	0·594	—	Bunsen.

¹ *Mém. Manch. Lit. and Phil. Soc.* vol. ii. third series.

The specific gravity of the metals not only varies with the temperature, but also with the physical condition. Thus cast metals or metals deposited by the galvanic current become denser when rolled or hammered. Electrolytic copper has a specific gravity of 8.952, and after hammering its density is 8.958; and that of cast zinc is 6.9, that of rolled sheet zinc being 7.2.

MELTING POINTS OF THE METALS.

7 The melting points of the metals also differ widely, as is seen in the following table:—

Mercury	- 40°
Gallium	+ 30
Potassium	62.5
Sodium	95.6
Lithium	180
Tin	235
Bismuth	270
Thallium	294
Cadmium	315
Lead	334
Zinc	423
Antimony	425
Silver	1000
Copper	1090

Other metals, such as iron and cobalt, fuse at a bright white heat, whilst platinum and iridium can be melted only in the oxyhydrogen flame, and osmium has not, as yet, been fused.

CRYSTALLINE FORM OF METALS.

8 Most metals, as well as their alloys, can be obtained in the crystalline state, and those occurring as minerals in the native condition are often found crystallized; this is the case with gold, silver, copper, platinum, iridium, palladium, gold-amalgam, and silver-amalgam. In general the form which they assume is one belonging to the regular system, such as the octahedron or the cube, or a combination of these forms. Some few, such as zinc,

antimony, and bismuth, crystallize in the hexagonal system, and the two latter metals, which closely resemble arsenic, are found, as this is, crystallized in rhombohedrons. On the other hand, a few metals, such as tin and potassium, crystallize in the quadratic system.

To obtain metals in the crystalline state several processes can be adopted. Crystals of metals which fuse readily can be obtained by solidification after fusion. Bismuth, antimony, lead, and tin may thus be crystallized, and in a similar way sodium and potassium; in the latter cases air must of course be excluded. Metals which are easily volatilized, such as zinc, cadmium, and potassium, may be obtained in crystals by condensation from the gaseous state, whilst other metals, such as silver, thallium, and lead, can be readily crystallized by the electrolysis of solutions of their compounds. In this case the metals separate out in lustrous crystalline plates, and the exhibition of this phenomenon on the screen forms one of the most striking and beautiful of lecture-room experiments, and is also well illustrated by the formation of the lead-tree when a piece of zinc is immersed in a solution of sugar of lead.

The fracture of metals is an important property intimately connected with the crystalline form, and in many instances it is of importance as giving a knowledge of the purity, or otherwise, of the metal. The following varieties of fracture are generally described:—

(1.) Crystalline fracture; as in antimony, bismuth, zinc, spiegel-iron, &c.

(2.) Granular fracture; as in grey forged pig-iron.

(3.) Fibrous fracture; as in bar and wrought iron when partly broken by bending.

(4.) Silky fracture; as in a piece of tough copper.

(5.) Columnar fracture; as observed in the grain tin of commerce.

(6.) Conchoidal fracture; noticed in the case of certain brittle alloys such as that composed of one part of copper to two of zinc (Percy).

Conductive Power for Heat and Electricity.—In their power of conducting heat and electricity, metals as a rule widely outstrip the non-metallic elements, as well as all chemical compounds. This property varies considerably in different metals, and also in the same metal according to its physical

condition and chemical purity. The soft metals conduct best, and at higher temperatures the conduction in all metals is less perfect than at lower ones. In 1833 Forbes¹ pointed out that the order of conducting power of the metals for heat and electricity is the same.

ATOMIC HEAT.

9 The specific heat of a body is the ratio of the quantity of heat required to raise that body 1° to the quantity required to raise an equal weight of water 1° (Maxwell). The amount of heat needed to raise a kilogram of water through 100° is thirty-one times as large as that required to raise the same weight of platinum through the same interval of temperature, or in other words, the same amount of heat which raises one kilogram of water through 100° will raise thirty-one kilograms of platinum through the same temperature; hence the specific heat of platinum is said to be $\frac{1}{31} = 0.032$. The specific heat of the same substance varies considerably under different physical conditions and according as the substance is solid, liquid, or gaseous.

An accurate determination of the specific heat of thirteen of the solid elements led Dulong and Petit in the year 1819² to the conclusion that the specific heat of the metals varies inversely as the atomic weight, so that if the specific heat of an element be multiplied by its atomic weight a constant number is always obtained. Hence the French experimentalists concluded that the atoms of different bodies possess the same capacity for heat, or all the elements have the same atomic heat. Although chemists at the time acknowledged the importance of this discovery, they did not consider that the conclusions arrived at were established beyond doubt, inasmuch as Dulong and Petit were obliged to alter their atomic weights in order to make their law applicable to certain of the elements whose specific heat they had determined. And although Berzelius allowed that in some cases such an alteration might be admissible, he showed that in certain instances the atomic weights which Dulong and Petit were obliged to adopt led in other respects to very improbable conclusions. Moreover, a few of

¹ *Phil. Mag.* iv. 27.

² *Ann. Chem. Phys.* x. 395.

the elements investigated by the French chemists were very impure, so that the specific heats which they obtained were inexact. Berzelius very properly insisted that further investigation was necessary, and adds,¹ "If we attempt to apply this idea to compound bodies, and if the result of such an examination confirms the views of Dulong and Petit, this discovery will rank as one of the most important parts of theoretical chemistry."

The next step in the direction thus indicated by Berzelius was made by F. Neumann,² who showed in the year 1831 that equivalent quantities of similarly constituted compounds possess equal specific heats, and that this equality is independent of difference in crystalline form; thus calc spar and arragonite both possess the same specific heat. Neumann, however, did not connect this discovery of the relation between the specific heats of the compounds with that of Dulong and Petit respecting the specific heats of the elements. Only by degrees, and in the hands of numerous observers was this connection brought about, and even at the present day it cannot be said that the subject is fully investigated. The researches which have mainly contributed to the development of this subject are those of Hermann, 1834, Regnault, 1840, De La Rive and Marcet, 1840, H. Kopp, 1864³ (whose memoir contains a historical introduction to the whole subject).

It is especially to the researches of Regnault that we are indebted for the corroboration of the results of the earlier experiments proving that the law of Dulong and Petit is applicable with a very considerable degree of accuracy to no less than forty of the elementary bodies, so that we may regard those weights of the elements to be their atomic weights, which, when multiplied into the specific heats of the elements, give a constant number. This is termed the capacity of the atom for heat, or the atomic heat of the element. If the atomic weight of hydrogen be taken as the unit, and if the capacity of water for heat be taken as one, then the numbers representing the atomic heats of most of the elements are found to lie near 6.4, or these elements possess the same atomic heat. This is clearly seen if we multiply the specific heats of the metals by their corresponding atomic weights, for example:—

¹ Berzelius's *Jahresb.* i. 19.

² *Pogg. Ann.* xxiii. 1.

³ *Ann. Chem. Pharm. Suppl. Band.* 1864, p. 1.

	Specific heat.		Atomic weight.	=	Atomic heat.
Lead	0·0315	×	206·4	=	6·5
Platinum , .	0·0324	×	196·7	=	6·4
Silver	0·0570	×	107·66	=	6·1
Tin	0·0548	×	117·8	=	6·5
Zinc	0·0955	×	64·9	=	6·2

The researches of Regnault and Kopp have proved that Dulong and Petit's law is approximately true for the greater number of the elements in the solid state and within a given range of temperature; so that this property may be employed for the purpose of controlling the determinations of atomic weight in doubtful cases. Amongst those elements which conform to the law are in the first place the metals, and then certain non-metals such as bromine, iodine, selenium, tellurium, and arsenic.

The following table shows within what limits the atomic heat of certain elements varies. The first column contains the names of the elements, the second their specific heats, the third the temperature at which the determination was made, the fourth the atomic weight, the fifth the product of the atomic weight into the specific heat, and the sixth the name of the observer:—

I.	II.	III.	IV.	V.	VI.
Bromine . . .	0·0843	- 51°	79·75	6·7	Regnault.
Iodine . . .	0·0541	+ 59	126·53	6·8	"
Selenium . . .	0·0840	+ 42	78·0	6·6	Beltendorf & Wülluer.
Tellurium . . .	0·0475	+ 36	128·0	6·1	Kopp.
Arsenic . . .	0·0822	+ 56	74·9	6·2	Neumann.
Potassium . . .	0·1660	- 34	39·04	6·5	Regnault.
Sodium . . .	0·2930	- 14	22·99	6·7	"
Lithium . . .	0·9410	+ 64	7·01	6·6	"
Calcium . . .	0·1700	+ 50	39·9	6·8	Bunsen.
Magnesium . . .	0·2500	+ 60	22·99	6·0	Regnault.
Zinc . . .	0·0955	+ 55	64·9	6·2	"
Cadmium . . .	0·0567	+ 55	111·6	6·3	"
Lead . . .	0·0315	+ 34	206·4	6·5	Kopp.
Thallium . . .	0·0335	+ 58	203·6	6·8	Regnault.
Copper . . .	0·0952	+ 58	63·0	6·0	"
Silver . . .	0·0570	+ 55	107·66	6·1	"
Mercury . . .	0·0319	- 59	199·8	6·4	"
Lanthanum . . .	0·04485	+ 40	139·0	6·2	Hillebrand.
Didymium . . .	0·04479	+ 40	147·0	6·3	"
Cerium . . .	0·04563	+ 40	141·2	6·7	"
Aluminium . . .	0·2140	+ 60	27·3	5·8	"
Indium . . .	0·0570	+ 50	113·4	6·5	Bunsen.
Manganese . . .	0·1220	+ 55	54·8	6·7	Regnault.
Iron . . .	0·1140	+ 58	55·9	6·4	"
Cobalt . . .	0·1070	+ 55	58·6	6·3	"
Nickel . . .	0·1080	+ 55	58·6	6·4	"
Wolfram . . .	0·0334	+ 55	184·0	6·1	"
Tin . . .	0·0548	+ 34	117·8	6·5	Kopp.
Zirconium . . .	0·0622	+ 50	90·0	6·0	Mixter and Dana.
Antimony . . .	0·0523	+ 31	122·0	6·4	Kopp.
Bismuth . . .	0·0305	+ 34	210·0	6·5	"
Gold . . .	0·0324	+ 55	196·2	6·4	Regnault.
Platinum . . .	0·0324	+ 55	196·7	6·4	"
Rhodium . . .	0·0580	+ 55	104·1	6·0	"
Palladium . . .	0·0593	+ 55	106·2	6·3	"
Iridium . . .	0·0326	+ 60	196·7	6·4	"
Osmium . . .	0·0311	+ 60	198·6	6·2	"

11 In this table the following non-metals, which Regnault and Kopp have found to possess smaller atomic heats, have been omitted:—

I.	II.	III.	IV.	V.	VI.
Sulphur . .	0.163	+ 31°	31.98	5.2	Kopp.
Phosphorus .	0.174	- 34	30.96	5.4	Regnault.
Boron . .	0.244	+ 55	11.0	5.4	"
Silicon . .	0.173	+ 55	28.0	4.8	"
Diamond . .	0.147	+ 45	11.97	1.8	"
Graphite . .	0.198	+ 50	"	2.4	"
Gas Carbon .	0.185	+ 36	"	2.3	Kopp.

These elements accordingly possess at temperatures between 0° and 100°, smaller atomic heats than correspond to Dulong and Petit's law. Recent investigations by Weber¹ have shown that the specific heat of carbon varies very considerably with the temperature, and that above a certain limit of temperature it remains constant and then follows Dulong and Petit's law, as is seen in the following table:—

Diamond	0.0635	-	50.5°	0.76
"	0.1128	+	10.7	1.35
"	0.1532		58.3	1.84
"	0.2218		140.0	2.66
"	0.2733		206.1	3.28
"	0.4408		606.7	5.29
"	0.4489		806.5	5.39
"	0.4589		985.0	5.51
Graphite	0.1138	-	50.3	1.37
"	0.1990	+	61.3	2.39
"	0.4454		641.9	5.35
"	0.4670		977.9	5.50

Similar results have been observed in the case of silicon. The specific heat of this element becomes constant at a temperature of 200°, giving an atomic heat of 5.65. Boron also exhibits the same phenomenon. The specific heat increases rapidly with the temperature, the constant limit being reached probably between 500° and 600°.

Weber's investigations have also shown that the allotropic modifications of a substance at low temperatures possess different

¹ *On the Specific Heat of the Elements Carbon, Boron, and Silicon.* Stuttgart, 1874.

specific heats, but that this difference diminishes as the temperature increases, and at last it altogether disappears. For example, Regnault concluded from his experiments that the specific heat of amorphous carbon was different from that of the two other modifications. Weber has, however, distinctly shown that this is not the case, but that carbon exists in two thermal modifications (1) opaque, (2) transparent. These thermal differences only occur at low temperatures, and when a high temperature is reached no variation is observed.

From the table we see that the atomic heats of the elements vary considerably even within the limits of temperature at which each appears to be constant. Thus, for instance, whilst the value for the majority lies between 6.1 and 6.5, in others the number sinks so low as 5.2, and in the case of the alkali metals and bromine and iodine the number rises to 6.9. These differences may, in some instances, be explained by the fact that the substances under investigation were impure. They may also be due, to a certain extent, to errors of experiment which may easily occur in working with bodies so readily oxidized as the metals of the alkalis. Still the differences cannot be thus altogether satisfactorily accounted for, and we must conclude that a variation of the specific heat with the temperature occurs not only in the case of carbon, boron, and silicon, but also, to a less degree, with all the other elements. This indeed has already been observed in some instances. Thus sulphur has an atomic heat, according to Kopp, of 5.2 at 31°, but at 67°, according to Regnault, of 5.7. Hence we might be inclined to argue that only those atomic heats which are determined at high temperatures are correct. But the difficulty recurs that many elements deviate altogether from Dulong and Petit's law when examined at temperatures near their melting points. The probable explanation of the whole matter is that the atomic heats are only constant within a limited range of temperature.

We must also remember that when we speak of specific heat we really refer to two quantities; in the first place, to the real specific heat which remains as heat, and secondly, that which goes to do work, such as expansion, and which, therefore, ceases to be heat. This last amount of heat is, however, different in the case of different substances, and if it could be determined we might probably find that Dulong and Petit's law is more strictly true than the measurements hitherto made have led us to suppose it to be.

The above law does not hold good for liquid or gaseous bodies with the single exception of mercury, which possesses the same atomic heat in the liquid and in the solid state.

MOLECULAR HEAT OF COMPOUNDS.

12 Kopp has shown that the atomic heat of an element does not undergo change when that element enters into combination. In other words, the molecular heat of a compound is equal to the sum of the atomic heats of its elements. The following examples will illustrate this :—

	Specific Heat.	Molecular Heat.	
		Found.	Calculated.
Potassium bromide KBr	0.1070	12.7	13.2
Mercuric iodide . . HgI ₂	0.0423	19.2	19.9
Lead iodide . . . PbI ₂	0.0427	19.6	20.1
Lead bromide . . . PbBr ₂	0.0533	19.5	19.9

Hence if the atomic heat of a solid element has not been determined it may be calculated from the molecular heat of its compounds with other elements whose atomic heat is known. In this way the atomic heats of rubidium, strontium, barium, and titanium have been determined, and they have been found to agree with the law which applies to all the other metals.

Kopp has also shown that the elements which are unknown in the solid state possess a constant atomic heat in their solid compounds. It thus becomes possible to determine the amount of their atomic heat. In this way the atomic heat of chlorine has been found to be equal to 5.9, that of nitrogen 5.3, of fluorine 5.0, of oxygen 4.0, and of hydrogen 2.3. The following examples illustrate this point :—

	Specific Heat.	Molecular Heat.	
		Found.	Calculated.
Silver chloride . . AgCl	0.089	12.5	11.9
Zinc chloride . . . ZnCl ₂	0.102	19.2	18.3
Potassium platinum chloride K ₂ PtCl ₆	0.118	57.4	55.0
Ice H ₂ O	0.478	8.6	8.6
Mercuric oxide . . HgO	0.048	10.4	10.3
Calcium carbonate . CaCO ₃	0.206	20.6	20.6
Potassium sulphate . K ₂ SO ₄	0.196	34.1	34.4
Hexachlorethane . C ₂ Cl ₆	0.177	41.8	39.3

This table shows that the two first elements obey the law. Fluorine does so approximately, but oxygen and hydrogen are seen to deviate considerably.

Kopp has moreover proved that the elements boron, silicon, and carbon possess, in combination, the same atomic heat as in the free state at temperatures below 100° . Hence it is not improbable that if we could obtain the specific heat of oxygen and hydrogen compounds at a high temperature the atomic heats of these elements might exhibit the same sort of alteration which has been proved to exist in the case of carbon, silicon, and boron.

13 The elements which possess a smaller atomic heat than the majority at temperatures below 100° are non-metals and have low atomic weights. All the non-metals whose atomic weights are high and all the metals, without exception, follow Dulong and Petit's law below 100° . Hence by help of the specific heat the atomic weights may in certain doubtful cases be controlled.

For instance, it was for some time a matter of doubt whether the metal thallium, discovered by means of spectrum analysis by Mr. Crookes, ought to be classed with the alkali-metals or with lead, inasmuch as it showed great analogy with both these elements. If classed with lead, the chloride of thallium must be represented by the formula $TlCl_2$, and its atomic weight must be 407.2. If it be classed with the group of alkali-metals the chloride must have the formula $TlCl$, and its atomic weight will be 203.6. Now Regnault determined the specific heat of thallium to be 0.0335, thus deciding the question in favour of the latter view, since $0.0335 \times 203.6 = 6.8$.

Indium is another new metal discovered by spectrum analysis. The chloride of this metal contains 37.8 parts by weight of metal to 35.46 parts by weight of chlorine. Indium, however, has a very considerable resemblance to zinc and cadmium, and for this reason the chloride was supposed to have the formula $InCl_2$, giving an atomic weight of 75.6 to the metal. In 1870 Bunsen¹ ascertained by means of his ice calorimeter that the specific heat of indium is 0.057. Now $0.057 \times 75.6 = 4.3$, or only two-thirds of the atomic heat of the other metals. Hence we must assume that the true atomic weight of the metal is $75.6 \times \frac{3}{2} = 113.4$. This would give the formula for the chloride, $InCl_3$.

In a similar manner the specific heats of the metals cerium,

¹ *Phil. Mag.* [4], xli 161, 392.

didymium, and lanthanum have recently been determined by Hillebrand with Bunsen's ice calorimeter¹ with the following results:—

Didymium	= 0.04563
Lanthanum	= 0.04485
Cerium	= 0.04479

Up to this time these metals were considered to be dyads, their lowest oxides were supposed to be monoxides DiO , LaO , CeO , the corresponding chlorides being DiCl_2 , LaCl_2 , CeCl_2 , and the atomic weights of these metals $\text{Di} = 98$, $\text{La} = 92.7$, $\text{Ce} = 94.1$, and their atomic heats 4.4, 4.1, and 4.1 respectively. If, however, we assume, as in the case of indium, that the lowest oxides of these metals are sesquioxides Di_2O_3 , Li_2O_3 , and Ce_2O_3 , then the above weights will become $\text{Di} = 147.0$, $\text{La} = 139.0$, $\text{Ce} = 141.2$, and their atomic heats will be in accordance with Dulong and Petit's law, viz., 6.7, 6.2, and 6.3.

As a fourth example the case of beryllium may be quoted. Emerson Reynolds has lately² shown that the amount of heat evolved by cooling 9.02 centigrams of beryllium heated to 100° is nearly equal to that evolved when 108 centigrams of silver is cooled through an equal interval of temperature. And that if the atomic heat of silver be 6.07 (107.66×0.0559), that of glucinum is 5.9, thus proving that the atomic weight of glucinum is not any multiple or sub-multiple of the number 9.0.

14 CLASSIFICATION OF THE METALS.

1. Metals of the Alkalis.

Potassium	K
Sodium	Na
Lithium	Li
Rubidium	Rb
Caesium	Cs

2. Metals of the Alkaline Earths.

Calcium	Ca
Strontium	Sr
Barium	Ba

3. Magnesium Group.

Beryllium	Be
Magnesium	Mg
Zinc	Zn
Cadmium	Cd

4. Lead Group.

Lead	Pb
Thallium	Tl

5. Copper Group.

Copper	Cu
Silver	Ag
Mercury	Hg

¹ *Fogg. Ann.* clviii. 71.

² *Phil. Mag.* [5], iii. 38.

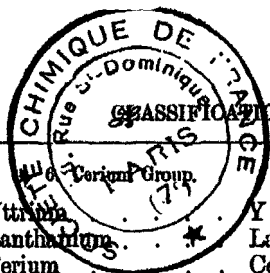

Yttrium	Y
Lanthanum	La
Cerium	Ce
Didymium	Di
Erbium	Er

7. Aluminium Group.

Aluminium	Al
Indium	In
Gallium	Ga

8. Iron Group.

Manganese	Mn
Iron	Fe
Nickel	Ni
Cobalt	Co

9. Chromium Group.

Chromium	Cr
Molybdenum	Mo
Tungsten	W
Uranium	U

10. Tin Group.

Tin	Sn
Titanium	Ti
Zirconium	Zr
Thorium	Th

11. Antimony Group.

Vanadium	V
Antimony	Sb
Bismuth	Bi
Tantalum	Ta
Niobium	Nb

12. Gold Group.

Gold	Au
Platinum	Pt
Ruthenium	Ru
Rhodium	Rh
Palladium	Pd
Iridium	Ir
Osmium	Os

15 The metals, like the non-metals, can be arranged in a certain number of groups dependent upon their chemical analogies. We have seen that the non-metals are classed in four divisions, according as each element is capable of combining with one, two, three, or four atoms of hydrogen to form a volatile compound. In the case of the metallic elements this mode of classification cannot be adopted, because, with the single exception of antimony, so intimately related to arsenic, none of the metals form volatile compounds with hydrogen. Many metals, however, resemble the non-metals in the power of uniting with the monad alcohol-radicals to form volatile compounds. These metallo-organic substances serve equally as well as the hydrides for the purpose of determining the quantivalence of an element, inasmuch as these may be considered to be hydrides in which each atom of hydrogen has been replaced by a monad-radical such as methyl, CH₃. This relation is seen in the following table:—

Hydrochloric Acid.	Water.	Ammonia.	Silicon Hydrido.
$\left. \begin{array}{c} \text{H} \\ \text{Cl} \end{array} \right\}$	$\left. \begin{array}{c} \text{H} \\ \text{H} \end{array} \right\} \text{O}$	$\left. \begin{array}{c} \text{H} \\ \text{H} \\ \text{H} \end{array} \right\} \text{N}$	$\left. \begin{array}{c} \text{H} \\ \text{H} \\ \text{H} \\ \text{H} \end{array} \right\} \text{Si.}$
Methyl Chloride.	Methyl Oxide.	Trimethylamine.	Silicon Methyl.
$\left. \begin{array}{c} \text{CH}_3 \\ \text{Cl} \end{array} \right\}$	$\left. \begin{array}{c} \text{CH}_3 \\ \text{CH}_3 \end{array} \right\} \text{O}$	$\left. \begin{array}{c} \text{CH}_3 \\ \text{CH}_3 \\ \text{CH}_3 \end{array} \right\} \text{N}$	$\left. \begin{array}{c} \text{CH}_3 \\ \text{CH}_3 \\ \text{CH}_3 \\ \text{CH}_3 \end{array} \right\} \text{Si.}$

The following volatile methyl compounds of the metals have already been prepared:—

Zinc Methyl.	Antimony Methyl.	Tin Methyl.
$\left. \begin{array}{c} \text{CH}_3 \\ \text{CH}_3 \end{array} \right\} \text{Zn}$	$\left. \begin{array}{c} \text{CH}_3 \\ \text{CH}_3 \\ \text{CH}_3 \end{array} \right\} \text{Sb}$	$\left. \begin{array}{c} \text{CH}_3 \\ \text{CH}_3 \\ \text{CH}_3 \\ \text{CH}_3 \end{array} \right\} \text{Sn.}$
Mercury Methyl.		Lead Methyl.
$\left. \begin{array}{c} \text{CH}_3 \\ \text{CH}_3 \end{array} \right\} \text{Hg}$		$\left. \begin{array}{c} \text{CH}_3 \\ \text{CH}_3 \\ \text{CH}_3 \\ \text{CH}_3 \end{array} \right\} \text{Pb.}$

These volatile compounds correspond to those which the metals, as well as the non-metals, form with the elements of the chlorine group. These may, therefore, also serve as a means of ascertaining the quantivalence of an element. Indeed in the case of the metals this method is especially valuable, as the metallic elements all combine with the members of the chlorine group to form compounds which can usually be easily volatilized. The following chlorides have been thus employed for ascertaining the quantivalence of their constituent metals.

I.	II.	III.	IV.	V.	VI.
	HgCl_2	SbCl_3	SnCl_4	NbCl_5	WCl_6
		BiCl_3	TiCl_4	TaCl_5	
			ZrCl_4		

In addition to these, the vapour density of the following metallic chlorides has been determined:—



16 If we assume that the quantivalence of a metal is determined by the number of atoms of a monad element with which

it can combine to form a compound capable of existing as a vapour without undergoing decomposition, vanadium must be a tetrad, and molybdenum a pentad metal. Tungsten in like manner forms a pentachloride, and might therefore be considered to be a pentad but for the fact that the hexachloride is known. This however leads us to class tungsten as a hexad, and as molybdenum in all its chemical characters resembles tungsten very closely, chemists have agreed also to represent molybdenum as a hexad.

Vanadium, again, exhibits in its general deportment a striking analogy with phosphorus and arsenic, whilst it is widely separated from the tetrad group of metals. These facts lead us to the conclusion that an argument drawn from the composition of the chlorides, both of the metals and non-metals, for the purpose of determining the quantivalence of the elements is much less cogent than one derived from the existence of compounds of the elements with hydrogen or with an organic radical. This is very clearly seen in the case of the members of the nitrogen group. All these elements unite with hydrogen to form volatile compounds, each of which contains three atoms of hydrogen in the molecule.

In their power of combining with chlorine these elements, however, do not exhibit the same uniform behaviour. Thus phosphorus combines with fluorine to form a very stable gaseous compound, phosphorus pentafluoride, PF_5 . With chlorine on the other hand phosphorus forms two compounds, a trichloride, PCl_3 , and a pentachloride, PCl_5 . The first of these is a very stable body, which can be volatilized without decomposition. The pentachloride cannot exist in the state of vapour as it begins to decompose into chlorine and the trichloride at a temperature not far above its boiling point, and when the temperature is gradually raised it is found to be wholly dissociated into these two components. The same thing is observed in the case of sulphur.

The dichloride, SCl_2 , corresponding to sulphuretted hydrogen, SH_2 , is so unstable that it decomposes at the ordinary atmospheric temperatures into the volatile monochloride, S_2Cl_2 , and chlorine. Selenium, on the other hand, possesses in addition to the hydrogen compound, SeH_2 , a stable tetrachloride, $SeCl_4$.

There is another important reason why the chlorides of the metals cannot always be employed for the determination of the quantivalence of the metals. The vapour density of the

majority of these chlorides has not yet been ascertained, as these compounds as a rule volatilize at such high temperatures that determinations of the kind have not been found practicable.

The volatile bromides and iodides serve even more imperfectly than the chlorides for controlling the quantivalence of an element, for the power of combination with bromine and iodine which the non-metals as well as the metals possess is, as a rule, less than in the case of chlorine. Thus phosphorus pentabromide can only exist at a low temperature, and when gently warmed it decomposes with tribromide and bromine, whilst a penta-iodide of phosphorus is unknown.

Hence it appears that in most cases we are obliged to content ourselves with the *apparent quantivalence* of a metal, by which the number of chlorine atoms are represented uniting with one atom of metal.

Other reasons however exist which render the classification of the metals according to their quantivalence a matter of difficulty. These we will now briefly discuss.

17 The alkali metals, together with silver and thallium, are usually supposed to be monads, the metals of the alkaline earths, those of the magnesium group, together with copper and silver, being classed as a dyad group. In some cases such a classification may probably be correct, in others again probably incorrect. Thus it appears almost certain that beryllium, magnesium, and cadmium, which form a natural group with zinc, resemble it in being dyads. In the same way too we may consider it almost certain that copper, which so closely resembles mercury in its chemical characters, is also analogous to it in being a dyad element. Each metal forms two chlorides:—

Mercurous Chloride, HgCl.	Mercuric Chloride, HgCl ₂ .
Cuprous Chloride, CuCl.	Cupric Chloride, CuCl ₂ .

Mercuric chloride is the only one of these compounds whose molecular weight has been ascertained by the determination of its vapour density, and as the metal in question is a dyad the constitution of the two chlorides is represented by the following formulæ:—

Mercurous Chloride.	Mercuric Chloride.
Cl—Hg—Hg—Cl.	Cl—Hg—Cl.

The corresponding copper compounds probably possess an analogous composition, viz. :—

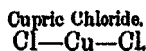
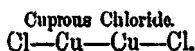

Silver most undoubtedly belongs to this same group. It forms only one well defined chloride, AgCl, which exhibits intimate chemical relationships with the lower chloride of the other two metals. Hence silver may be regarded as a dyad metal even though it does not form a dichloride. And in confirmation of this conclusion it must be remembered that copper forms only one compound with iodine, viz., cuprous iodide, Cu₂I₂, cupric iodide being unknown. Thus it is clear that the simple formula AgCl no more represents the truth than does the formula PbCl₂ for lead chloride. We know that lead is a tetrad from the existence of the volatile methyl compound Pb(CH₃)₄, and hence the molecular formula of the chloride must be some multiple of the simplest formula. The most probable supposition is that the molecule contains two atoms of lead, and that these are united by two combining units, thus:—

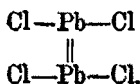

It is, however, possible that its molecular formula may be Pb₃Cl₆, Pb₄Cl₈, or any higher multiple.



Again, the metals calcium, strontium, and barium form many compounds which possess the greatest similarity, and are isomorphous with corresponding compounds of lead. Hence we may fairly conclude that these metals possess the same quantivalence as lead, although, like lead, they form no tetrachlorides, but only dichlorides.

Aluminium unites with chlorine, bromine, and iodine to form the volatile compounds Al₂Cl₆, Al₂Br₆, Al₂I₆. The molecule of each of these compounds contains two atoms of metal which must be linked together, and the simplest supposition is that aluminium is a tetrad:—

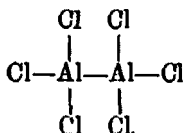

18 Indium is closely related to aluminium. The formula of its chloride, InCl_3 , will accordingly in all probability have to be doubled. Thallium is also connected with this group, but the trichloride TlCl_3 or Tl_2Cl_6 is a very unstable compound, whilst the monochloride TlCl is a stable one. As thallium exhibits a remarkable similarity to the alkali-metals it is usually considered to be, like them, a monad element. Still we are as yet without proofs that this is really the case, for although the alkali-metals yield only one chloride, we are not acquainted with the vapour densities of these compounds, so that the existence of only one chloride does not indicate the monad character of potassium any more than the existence of two atoms of chlorine in lead chloride shows lead to be a dyad. We must conclude that until vapour densities of these compounds have been obtained it is idle to discuss the quantivalence of the alkali-metals. At the same time we may remember that the chlorides are as a rule not easily volatilized, and this serves as an argument to prove that their molecule is not a very simple one. For if potassium, itself an easily volatilizable metal, forms a chloride having the formula KCl , we should expect this more simple compound to be more volatile than the more complicated molecule of mercuric chloride, HgCl_2 . The formulæ KCl , TlCl , AgCl , &c., have the same meaning as was assigned to the formula CCl , used for hexachlorobenzene, before it was known that the molecular formula of that body is C_6H_6 .

Iron forms a volatile chloride, Fe_2Cl_6 , corresponding to aluminium chloride, and as these two metals yield many isomorphous compounds, iron is usually considered to be a tetrad element. In addition to ferric chloride, Fe_2Cl_6 , we are acquainted with ferrous chloride FeCl_2 . If iron be really a tetrad this latter compound may be represented as Fe_2Cl_4 . The constitution of the two iron chlorides would then be analogous to that of the two chlorides of carbon:—

Hexachlorethane.



Tetrachlorethane.



Ferric Chloride.



Ferrous Chloride.



The constitution of ferrous chloride may, however, equally well be represented by the formulæ, Fe_3Cl_6 , Fe_4Cl_8 , &c. :—

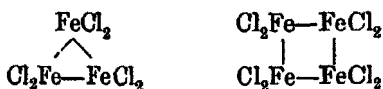

These latter formulæ in fact are more probable than the former. We find that in a group of similar bodies simplicity of molecular construction is accompanied by a lower boiling point. Thus tetrachlorethane boils at 122° , whilst the boiling point of the more complicated hexachlorethane is 182° . Ferric chloride, however, is much more volatile than ferrous chloride, and hence we should be inclined to believe that the molecular weight of the former is less than that of the latter compound.

The above examples clearly show that we are at present unable to determine with any degree of certainty the true quantivalence of those of the metals which do not form volatile compounds. In such cases we are obliged to content ourselves with ascertaining the apparent quantivalence, and we must not forget that the formulæ which we thus obtain are not molecular formulæ. For we have very good reason for believing that the simple formulæ with which we usually express the composition of the metallic oxides are not true molecular formulæ. Thus K_2O potassium oxide, ZnO zinc oxide, Sb_2O_3 antimony oxide, are the oxides of volatile metals, and if the molecules of the oxides are truly represented by the above formulæ we should be inclined to anticipate that they were likewise volatile bodies. This is however not the case. Antimony is closely related to arsenic and phosphorus, and we know that the former of these two elements forms an oxide having the molecular formula As_4O_6 , and a constitution which may be represented as follows :—

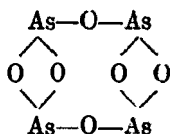

The trioxides of phosphorus and antimony in all probability possess a similar constitution.

Zinc is a dyad, and the constitution of its oxide may be either

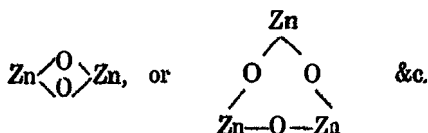

Similar considerations apply to the constitution of the salts of the metals. We shall have occasion to refer to this in a subsequent chapter.¹

OXIDES AND HYDROXIDES.

19 All the metals combine with oxygen. Some, such as those of the alkalis and alkaline earths, unite with oxygen so readily that they have to be preserved out of contact with air or with any compound containing oxygen. Other metals withstand the action of oxygen at the ordinary temperature, but combine with it when heated. When the metals are easily volatile, as is the case with magnesium and zinc, they burn with a bright flame in the air or in oxygen. If they do not volatilize readily, like tin and lead, the metals gradually undergo oxidation without evolution of light and heat. A few metals such as gold and platinum cannot be made to unite directly with oxygen, even at the highest temperatures. The oxides of such metals can however be prepared by indirect means. Chlorine attacks all metals, and if the chlorides of these metals which are not directly oxidizable be decomposed by an alkali, their oxides are formed thus:—



The metallic oxides may be divided into three groups, (1) Basic oxides, (2) Peroxides, (3) Acid-forming oxides.

(1.) *Basic Oxides.*—The most characteristic property of this class of oxides is their power of uniting with acids to form salts. In this act of combination water is always formed. Hence these oxides may be regarded as water in which hydrogen is replaced by a metal. When this replacement is only a partial one, compounds termed *hydroxides* are produced. These were formerly called *hydrates*, as they were supposed to be compounds of the oxides with water.

The soluble oxides and hydroxides possess an alkaline reaction ;

¹ See Lothar Meyer, *Die moderne Theorien der Chemie*, 3to Aufl. 220-243.

they colour red litmus paper blue, turn yellow turmeric paper brown, and change the tint of many red and violet vegetable colours to green. The hydroxides of the alkali-metals are the most soluble. They are termed *alkalis*, and are distinguished by their caustic taste. The hydroxides of the metals of the *alkaline earths* are less soluble. Most of the other hydroxides and basic oxides are almost insoluble in water. Exceptions to this law are seen in the case of thallium hydroxide, which is very soluble in water, as well as in the oxides of lead, silver, and magnesium, which dissolve very slightly.

Many metals yield two or more basic oxides, and corresponding hydroxides. These compounds may be represented as water in which the hydrogen is wholly or in part replaced by metal. Thus :—

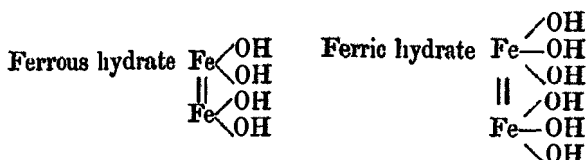
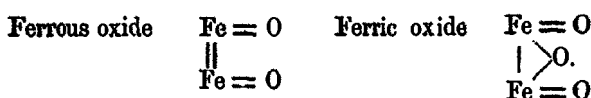
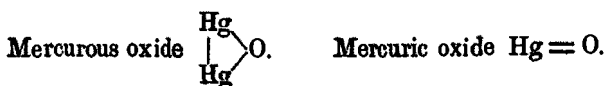

It need scarcely be remarked that the above are not molecular formulæ. They simply serve to express the fact that if the metal be replaced by hydrogen, as may readily be effected by the action of an acid, water and a salt are the only substances formed.

(2.) *Peroxides*.—This class of oxides contain more oxygen than the basic oxides. When heated they usually yield the corresponding basic oxide, and in this respect resemble hydrogen peroxide, which readily decomposes into water and oxygen.

Treated with hydrochloric acid they give rise either to (1) hydrogen peroxide, or (2) chlorine :—

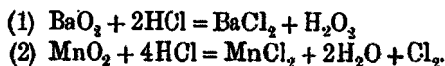

When sulphuric acid acts on a peroxide with formation of either hydrogen peroxide or oxygen, the latter reaction always occurs when the mixture is heated, thus:—



(3.) *Acid-forming Oxides*.—These oxides are especially characteristic of the non-metallic elements, though they likewise occur amongst the metals. They contain more oxygen than the peroxides, and they are characterized by their power of combining with water to form hydroxides, which are termed *acids*.

In the case of the metals as in that of the non-metals, it not unfrequently happens that the acid corresponding to the acid-forming oxide is either not known in the free state, or can only be obtained in aqueous solution.

No well-defined line can be drawn between these three classes of oxides. It is easy to distinguish between the extreme members of the series, as the *alkalis*, or *alkaline earths*, and oxides, which form strongly acid hydroxides. But we are acquainted with many cases in which basic oxides or peroxides act as weak acids in presence of powerful bases, whilst on the other hand many peroxides and acid-forming oxides play the part of bases towards a strong acid.

ACIDS.

20 The only acid known to the ancients was vinegar or acetic acid. Hence the name of this substance and the notion of acidity were represented by closely-related words (*ὄξος*, *acetus*, vinegar; *ἄξως*, *acidus*, acid). The power of vinegar to produce an effervescence when brought on to the carbonate of an alkali was observed in early times. Thus we read in Proverbs xxv. 20, "As he that taketh away a garment in cold weather, and as vinegar upon nitre, so is he that singeth songs to an heavy heart." Nitre in this case stands for natron or native carbonate of soda. It was also well known that vinegar acts as a solvent upon many substances, as in the celebrated story of Cleopatra dissolving pearls. The Arabians were acquainted with many other acids. Geber termed nitric acid *aqua dissolutiva*, and he gives the same name to the liquid obtained by strongly heating alum in a retort, which was probably dilute sulphuric acid. This shows that the special characteristic of an acid, according to the older alchemists, was its power of dissolving

substances which are insoluble in water. Other properties common to the whole class of acids were not observed until a much later date. In 1668 Tachenius noticed that all acids are capable of combining with alkalis. Hence he considered silica to be an acid. Boyle¹ defines an acid as follows: "It is a body which (1) acts as a solvent but acts with varying power on different bodies; (2) It precipitates sulphur and other bodies from their solutions in alkalis; (3) It turns blue vegetable colouring matter red, whilst alkalis bring the blue colour back again; (4) It can combine with an alkali when the characteristic properties of each body disappear and a neutral salt is formed." These properties were henceforward regarded as the special characteristic of acids, and accordingly F. Hofmann in 1723 asserted that the *spiritus mineralis*, which exists in many mineral springs, and which we term carbonic acid, belongs to the class of acids as it turns blue litmus solution red. Forty years later Bergmann strengthened this conclusion by showing that this same substance possesses the power of destroying the caustic nature of the alkalis, giving rise to a distinct class of salts.

The question as to the essential nature of acids was one often discussed, but no definite result was arrived at inasmuch as experiment was not appealed to. Lavoisier pointed out that the element oxygen was contained in all the acids which he examined, and accordingly he gave to this substance the name which it now bears. The fact that all acids contain oxygen, was soon generally acknowledged. But, on the other hand, it was denied by some, especially by Berthollet, that oxygen is the acidifying principle. He based this conclusion on his experiments upon prussic acid and sulphuretted hydrogen, both of which are acid bodies although they do not contain any oxygen. These opinions however met with but little recognition. Lavoisier's views carried the day, and oxygen was generally considered to be the true acidifying principle, it being assumed that sulphuretted hydrogen and prussic acid contained this element. The next step in the progress of our knowledge on this subject was Davy's investigation on chlorine and hydrochloric acid, carried out in 1808-1810. He proved that a powerful acid exists which certainly does not contain oxygen. Gay-Lussac's discovery of hydriodic acid, and the proof that prussic acid likewise contains no oxygen, soon came in corroboration.

¹ *Reflections upon the Hypothesis of Alkali and Acidum*, iv. 284.

ration of this view. Acids were henceforth divided into two classes: the *oxy-acids*, and the *hydracids*. Under the first heading were placed all those bodies to which we now give the name of acid-forming oxides. The true oxy-acids were considered to be the hydrates of these oxides.

Much discussion as to the nature of the true acidifying principle followed these discoveries. Gay-Lussac, reasoning from the composition of the hydracids such as hydrochloric, hydriodic, &c., believed that hydrogen is to be regarded as the essential constituent of an acid, whilst in the case of the oxy-acids, oxygen is the acid-producing substance. Dulong was the first to suggest, in 1816, that all acids must be considered as belonging to one type, that they all contain hydrogen on the one hand and some other element or groups of elements on the other. This idea was, however, by no means generally admitted by chemists of the time, and it is only in recent years that this view has been reproduced and almost universally adopted.

The subsequent development of this theory is intimately connected with the subject of the constitution of salts, which we now proceed to discuss.

CONSTITUTION OF SALTS.

21 The word salt even at the present day is commonly applied to sea-salt or sodium chloride, and there can be little doubt that originally the term was given to the same substance, the Greek form of the word ($\alpha\lambda\varsigma$), in the feminine being used for the sea itself, whereas in the masculine it denoted the solid residue left when sea water is evaporated. The growth of the application of the word salt from a special to a generic term, appears to have had its origin in the fact that just as common salt is obtained by the evaporation of sea-water, so other kinds of salt can be obtained by the evaporation of other liquids, as when, for instance, wood-ashes are boiled with water the clear solution yields on evaporation a white soluble residue to which the name of salt was applied. This extension of the term, as Kopp remarks, was, however, not accompanied by any knowledge of the differences between the substances thus classed together, exhibiting indeed ignorance with respect to the chemical differences of these various soluble substances. Even up to the end of the last century the wider application of the word salt may be said to have been prevalent. Amongst the alchemistic writings of

the thirteenth century the words salpetræ, salnitri, salnarium, salarmoniacum, salvegetabile and the like occur; these bodies are all soluble in water and may be again obtained from solution by evaporation. The ideas connected with these salts were vague and indefinite. But a new meaning was given to the word salt by Basil Valentine. He applied the term to the solid bodies obtained by the combustion of substances. This view was also upheld by Paracelsus, and was generally, though not universally, adopted by chemists. Thus we find in the seventeenth century that salt was considered to be one of the hypothetical essential constituents of all bodies, all inorganic substances being made up of salt, sulphur, and mercury (see Historical Introduction, Vol. I. p. 6). This view of the word salt as an essential constituent of all bodies was strongly opposed by Boyle, who paid much attention to the investigation of salts, and to whom we owe much of our knowledge of the special nature of the different salts. He was not able, however, exactly to define to what class of bodies the term salt ought to be applied. This was specially accomplished by Boerhave, who in his *Elementia Chemicæ*, published in 1732, describes the special properties of salts to be their solubility, fusibility, volatility, and taste. According to this definition, however, alkalis and acids must also be considered as salts, and these were, therefore, divided into *salia alcalina*, *salia acida*, *salia salsa*, *salia media*, *salia neutra*, and *salia composita*. Under the last named was understood a class of salts obtained by the union of an acid with an alkali or metallic calx. The chief characteristics of the salt still remained—their solubility and peculiar taste. It was soon seen that such a definition leads to contradictions, for baryta, nitric acid, and sulphuric acid would thus be salts as well as nitrate of barium, whilst sulphate of barium, which is insoluble and, therefore, possesses no taste, would not be a salt. Hence the necessity became obvious of separating alkalis and acids from the true salts, or *salia media* as they were called, and the word salt was now taken to mean such substances as are obtained when an acid and a base are brought together or when an alkali or metallic calx is neutralized by an acid. After the fall of the phlogistic system, and after Davy's discovery of the compound nature of the alkalis, it was generally admitted that all salts are compounds of a basic- with an acid-oxide. This definition, however, became unsatisfactory as soon as the hydracids were discovered. From this time forward salts were divided into two

classes, those which contain oxygen and are termed *amphid* salts and those which are free from oxygen and are termed *haloid* salts. Berzelius included the sulpho- and seleno-salts under the term amphid salts, inasmuch as these elements like oxygen form basic as well as acid compounds. Hence he termed these elements *amphids*, whilst to the elements of the chlorine group which combine directly with metals to form salts he gave the name *haloids*. This view held its ground for a considerable length of time, although it necessitated a different explanation for reactions which are in fact similar. Thus, for instance, when hydrochloric acid acts upon zinc it was assumed that the metal simply replaced the hydrogen of the acid :

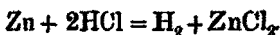

When, however, sulphuric acid acts upon zinc it was necessary to assume that the presence of the acid enabled the zinc to decompose the water (predisposing affinity) in order that an oxide may be formed with which the acid can unite; the reaction was, accordingly, represented as taking place in two stages :

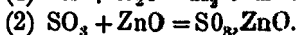
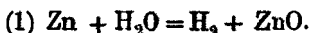

In the same way when hydrochloric acid combines with lime, water is formed. On the other hand, when the same base combines with sulphuric acid no water is produced :

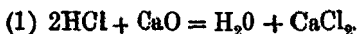

22 In 1838, Liebig published his important investigation on the constitution of the organic acids. In this memoir,¹ he discussed the question whether the salts and oxyacids are compounds of a metallic oxide or of water with an acid-oxide, or whether Dulong and Davy's view is the more correct one, viz., that all acids and salts may be represented as combinations of metals, or of hydrogen, with elements or groups of elements. Liebig points out that this latter definition does away with the differences between oxyacids and hydracids, and between amphid salts and haloid salts. According to this view, acids are simply hydrogen compounds, and when this hydrogen is replaced by a metal a salt is formed. In Liebig's opinion the view is less

¹ *Ann. Pharm.* xxvi. 113.

applicable to inorganic than to organic compounds. Nor was it until certain facts became known which were favourable to this theory, that it was generally admitted that acids and salts possess an analogous constitution.

If aqueous hydrochloric acid is decomposed by a galvanic current, chlorine is evolved at the positive pole and hydrogen is liberated at the negative. If dilute sulphuric acid is treated in a similar way a simple decomposition of water apparently takes place, for at the positive pole we obtain pure oxygen and at the negative pure hydrogen. The same phenomenon is observed in the electrolytic decomposition of a solution of sodium sulphate, but at the same time sulphuric acid is liberated at the positive pole whilst soda makes its appearance at the negative pole together with the hydrogen. Hence, in this case, it was argued that the current decomposed both the water into its elements and the salt into its immediate components. If a solution of sulphate of copper be subjected to the same treatment oxygen is evolved at the positive pole and sulphuric acid liberated, whilst at the negative pole metallic copper separates out; this was explained by the supposition that the copper oxide which ought to be deposited is reduced to the condition of metal by the nascent hydrogen.

These phenomena were specially examined by Prof. Daniell.¹ It appeared to him important to determine the relation between the quantity of oxygen and hydrogen, on the one side, and of the acid and the alkali on the other, formed in the electrolysis of a salt of an alkali; and as the result of a large number of careful experiments he found that these several substances are produced in the proportion of their equivalents, and that this is true not only in the case of sodium sulphate, but also in the cases of other salts of the alkalis. Daniell also observed the remarkable fact that the same current which apparently is capable of producing these two decompositions is capable of liberating exactly the same quantity of hydrogen and of oxygen from dilute sulphuric acid. In this latter case, therefore, the current was apparently able to effect only half the work which it was capable of producing in the decomposition of an aqueous saline solution, because in this case not only the salt but, as it seemed, the water also, underwent decomposition. This is however clearly impossible, and the phenomena observed can be readily explained by assuming that in the decomposition both of aqueous

¹ *Introduction to Chemical Philosophy*, second edition, p. 533.

sulphuric acid and of the solution of a sulphate, either hydrogen or a metal is liberated at the negative pole, whilst at the positive pole the group SO_4 is set free. But this cannot exist in the free condition, as it decomposes at once into oxygen and sulphur trioxide, the latter dissolving instantly with formation of sulphuric acid. When a salt of an alkali is decomposed, the metal which is evolved instantly decomposes the water with evolution of hydrogen. According to this view the electrolytic decomposition of the oxysalts is exactly analogous to that of the chlorides, and hence they must be similarly constituted. Daniell proposed a new nomenclature for the oxysalts:

HSO_4	Hydrogen oxysulfion.
Na SO	Sodium oxysulfion.
HNO_3	Hydrogen oxynitron, &c.

This proposal has, however, never been generally adopted, and even the old views respecting the constitution of the oxysalts can only be said to be slowly disappearing.

23 If we ask ourselves the question, What is the cause of the acid character of bodies? we may say that acids must contain hydrogen together with certain elements or groups of elements which are termed negative elements or groups, inasmuch as these are separated out at the positive pole in the act of electrolysis. A compound may however contain both these negative elements or groups of elements, and also hydrogen, and yet not belong to the class of acids. Hence it appears that the atoms or groups of atoms must be combined with hydrogen according to a particular plan in order that the compound may assume the character of an acid. Sir Humphry Davy,¹ in 1816, pointed out perfectly correctly, that it is impossible to assert that a particular body is an acid-forming or an alkali-forming principle, and that such a definition would be to introduce nothing more than *qualitates occultas* into science. The chemical properties of a body are, said Davy, determined by "the corpuscular arrangement" of the constituent particles.

Amongst the different acids the hydrogen compounds of the elements of the chlorine group possess the simplest constitution. They contain one atom of hydrogen combined with one atom of a powerful negative element. In the oxygen acids the hydrogen which can be replaced by metals is always found to be combined with oxygen in the form of the radical hydroxyl, OH , but it

¹ *Jour. Sc. and Arts, Roy. Inst.* 1816.

still does not follow that the number of hydroxyl molecules represents the basicity of an acid, although this is frequently the case, as is seen by the following examples :—

Hypochlorous Acid.



Nitric Acid.



Sulphuric Acid.

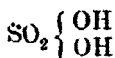

Phosphoric Acid.

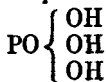

The organic acids assist us more than any other class in the solution of the problem, as to what determines the acid nature of a compound. In by far the majority of these bodies the group OH is combined with the group CO ; hence the following are monobasic :—

Formic Acid.

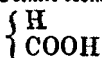

Acetic Acid.

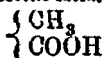

Oxyacetic Acid.

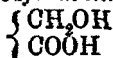

Whilst on the other hand the following are dibasic :—

Malonic Acid.

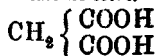

Succinic Acid.

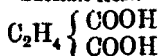

The monad radical of nitric acid, nitroxyl, NO_2 , can also in combination with carbon give rise to acids, but only when the carbon atom with which the nitroxyl is connected is also combined with hydrogen. Thus, if one atom of hydrogen in ethane be replaced by nitroxyl we obtain the acid nitro-ethane which, when acted upon by bromine, a strongly negative element, is converted into a strong acid bromonitro-ethane, $\text{C}_2\text{H}_4\text{BrNO}_2$. If however one atom of hydrogen in this compound be replaced by bromine, a perfectly neutral substance is obtained termed dibromonitro-ethane, $\text{C}_2\text{H}_3\text{Br}_2\text{NO}_2$. The constitution of these bodies is as follows :—



The four atoms of hydrogen of marsh gas can also be replaced by nitroxyl :—



The three first of these substances are acids, whilst the fourth is a perfectly neutral substance.

Salts may be classed into several groups.

24 (1) *Normal salts* are those in which the whole of the replaceable hydrogen is completely replaced by a metal. These were formerly called *neutral salts*, or *salia media*, because it was noticed that when an alkali was added in the right proportion to a powerful acid the resulting salt possessed neither an alkaline nor an acid reaction. This is, however, not the case with every normal salt. Those which are formed by the action of a weak acid on a strong base, when they are soluble in water usually possess an alkaline reaction: such are potassium carbonate, K_2CO_3 ; sodium phosphate, Na_3PO_4 . On the other hand, the normal salts obtained by neutralizing strong acids with weak bases have an acid reaction, thus aluminium sulphate, $Al_2(SO_4)_3$; copper sulphate, $CuSO_4$, and many other salts of the heavy metals.

Polybasic acids can form salts containing two or more different metals; thus, for instance, potassium sodium carbonate, $CO \begin{cases} OK \\ ONa \end{cases}$. Polyatomic metals, on the other hand, often give rise to salts which contain two acid radicals: thus, $Sr \begin{cases} ONO_2 \\ OC_2H_3O \end{cases}$, a compound which is at the same time a nitrate and an acetate; as another example the mineral vanadinite may be cited, $VO \begin{cases} O \\ O \\ OCaCl \end{cases} Ca$, which is a calcium salt of tribasic vanadic acid and at the same time a chloride.

25 (2) *Acid salts* are formed when only a portion of the replaceable hydrogen contained in a polybasic acid is substituted by a metal. The acid salts often possess an acid reaction, as is the case with the acid potassium sulphate, $SO_2 \begin{cases} OK \\ OH \end{cases}$ but this reaction is dependent on the nature of the acid and the base. Thus, hydrogen potassium carbonate, $CO \begin{cases} OK \\ OH \end{cases}$ has a neutral reaction; common or rhombic sodium phosphate, $PO \begin{cases} ONa \\ ONa \\ OH \end{cases}$ possesses a slightly alkaline reaction, whilst the dihydrogen sodium phosphate, $PO \begin{cases} ONa \\ OH \\ OH \end{cases}$, is slightly acid.

(3) A third class of salts is formed by the union of a normal

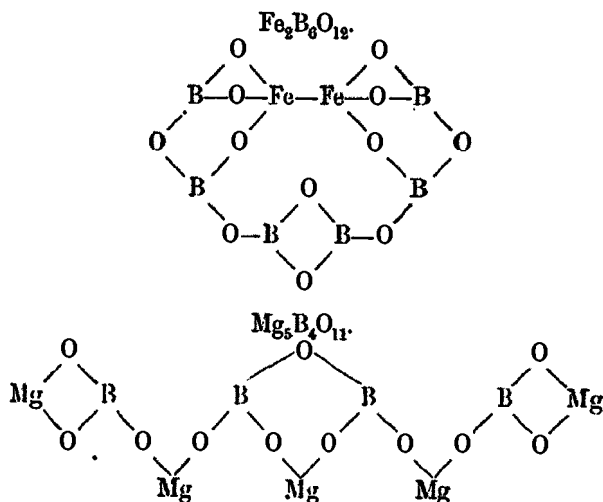

The class of silicates, which as a rule have a complicated constitution, may also be represented in a similar way; the following examples may be taken as illustrations of this class:—

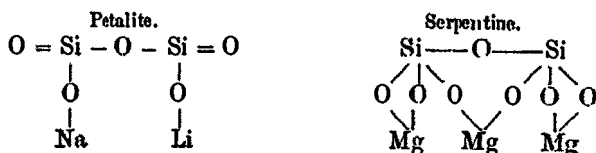

Of course the atoms may be represented as grouped in different ways; the above formulæ are only intended to point out how the atoms of triad boron and tetrad silicon may be held together in a compound.

(4) *Basic salts* are formed by the combination of a normal salt with an hydroxide. Thus, if a solution of lead nitrate be boiled with lead hydroxide, a basic lead nitrate is formed:

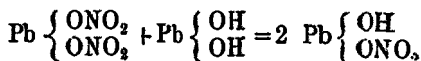

In the same way basic zinc chloride, $\text{Zn} \left\{ \begin{array}{l} \text{Cl} \\ \text{OH} \end{array} \right.$, may be obtained.

Basic bismuth nitrate, on the other hand, is obtained by the action of water on the normal salt:

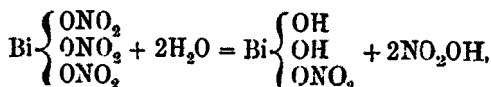

Amongst other basic salts may be mentioned:—

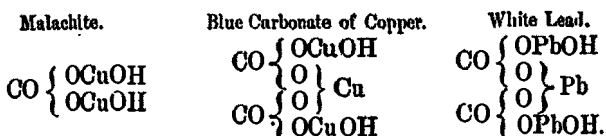

All these basic salts may be considered to be both salts and basic hydroxides. But we are acquainted with certain salts which do not contain any hydrogen; thus, for instance, basic mercuric sulphate, $\text{Hg}_3\text{SO}_6 = \text{HgSO}_4 + 2\text{HgO}$. The constitution of this compound may be represented as follows—



SOLUBILITY OF SALTS.

26 Many salts dissolve in water. Some are very soluble, others are less so. The following table serves to illustrate the variation in the solubility of different salts.

100 parts of water at 15° dissolve—

	Parts.
Calcium chloride, CaCl_2	400
Potassium carbonate, K_2CO_3	110.5
Sodium chloride, NaCl	36.9
Potassium nitrate, KNO_3	26.0
Potassium sulphate, K_2SO_4	10.2
Potassium perchlorate, KClO_4	1.5
Calcium sulphate, CaSO_4	0.236
Strontium sulphate, SrSO_4	0.0001
Lead sulphate, PbSO_4	0.00007.

The following salts are insoluble in water: barium sulphate; silver chloride; most of the silicates, &c.

A reduction of temperature generally occurs when a salt is dissolved in water, inasmuch as heat is absorbed by the passage from the solid to the liquid condition. On the other hand, certain anhydrous salts evolve heat on solution, because they combine with water to form hydrates, and because the amount of heat given out in this act of chemical combination is greater than that absorbed by the liquefaction of the salt.

Salts are as a rule more soluble in hot than in cold water, and

for this reason a portion of the salt is deposited in the form of crystals when the hot saturated solution is allowed to cool. In some instances the solubility increases at a rate proportional to the temperature. This is clearly seen in the case of potassium chloride, the solubility of which in 100 parts of water is shown by the following table:—

	Parts.	Difference.
At 10°	32	
20°	34·7	2·7
30°	37·4	2·7
40°	40·1	2·7
50°	42·8	2·7
100°	56·6	5 × 2·7

Generally, however, the solubility increases more rapidly than the temperature. For instance, 100 parts of water dissolve the following quantities of nitre:—

	Parts.	Difference.
At 10°	21·1	
20°	31·2	10·1
30°	44·5	13·3
40°	64·0	19·5
50°	86·0	22·0
100°	247·0	

A saturated saline solution always boils at a temperature above 100°. The increment above 100° is, however, not proportional to the amount of salt dissolved, as is shown by the following examples:—

	Boiling point.	100 parts of water dissolve
Sodium chloride	109°	41·8
Potassium nitrate	114°	327·4
Potassium iodide	118°	223·0
Potassium carbonate	135°	205·0

In the case of a salt whose solubility does not increase proportionally with the temperature, the increase may be ascertained by an interpolation formula similar to those employed in the calculation of the solubility of gases. The different constants in the equation have of course to be obtained as the results of direct experiment. Thus, for nitre, at t° , where S represents the solubility of the nitre, the expression is:—

$$S = 13\cdot32 + 0\cdot5738t + 0\cdot017168t^2 + 0\cdot000035977t^3.$$

The solubility of salts may also be represented graphically, as is seen in Fig. 1. The abscissæ give the temperatures, and the ordinates indicate the amount of salt which dissolves at this temperature in 100 parts of water.

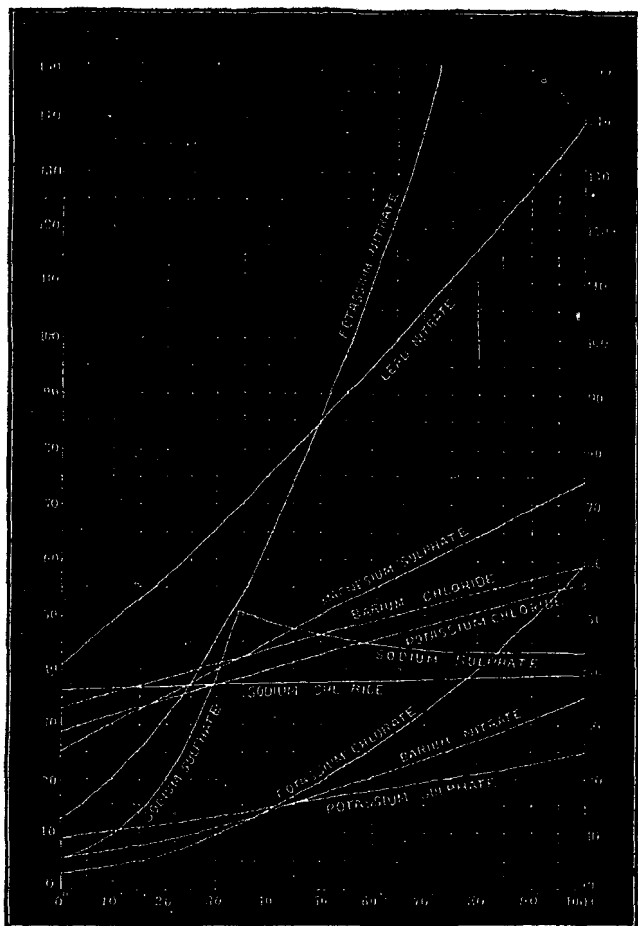

FIG. 1.

If the solubility of a salt increases proportionally to the temperature, as is the case with potassium chloride, the curve of solubility becomes a straight line, whilst in cases where this

proportion does not exist, the lines of solubility are more or less curved.

The most remarkable case of solubility is that of sodium sulphate, or Glauber's salts. The curve of solubility of this salt rises rapidly from 0° to 33° , but from this point the solubility again diminishes, and at higher temperatures is seen to be still less. This depends upon the fact that when this salt is dissolved, the hydrate $\text{Na}_2\text{SO}_4 + 10\text{H}_2\text{O}$ exists in solution, and, either alone or in solution, it undergoes a decomposition at a temperature of 33° into water and the anhydrous salt. The latter differs from most salts, inasmuch as it is more soluble at low than at high temperatures. Similar phenomena are observed in the case of other salts, such as sodium carbonate, which is most soluble in water at 36° . A singular instance of abnormal solubility is found in the case of calcium sulphate. This dissolves more readily in cold than in hot water, and is quite insoluble in water at 120° . Other calcium salts, especially those of organic acids, exhibit the same property of being much more soluble in cold than in hot water.

In the case of many salts, especially of those which contain water of crystallization, such as sulphate, carbonate, and acetate of sodium, the remarkable fact is observed that when the saturated solution is allowed to cool quietly in closed vessels, no crystals separate out, the liquid remaining perfectly transparent. Such a solution is said to be supersaturated. It contains an excess of salt in solution, and this, when the liquid is allowed to remain undisturbed, and is not cooled down to too low a temperature, does not deposit in the form of crystals. If, however, the solution be shaken or stirred, or if a crystal of the salt be thrown into the liquid, or even if atmospheric dust come in contact with it, crystals at once begin to form and in a few moments the whole mass becomes solid, a considerable elevation of temperature accompanying this solidification. Sodium acetate is a salt which is well adapted to show the phenomenon of supersaturation in a striking manner. For this purpose the crystallized salt is gently warmed in a flask with a small quantity of water until all is dissolved, care being taken not to allow any of the crystals to remain attached to the glass above the solution. The neck of the flask is then closed with a plug of cotton-wool and the whole allowed gradually to cool. If the smallest crystal of sodium acetate be thrown into the liquid when cold, a crystallization at once commences round the small

particle, and in a few seconds the whole has assumed the solid form. This singular crystallization appears to be brought about only when the solution comes in contact with a solid or probably with a crystalline body, or when the solution is cooled down to a low temperature. Thus, for instance, air which has been rendered free from dust by means of sulphuric acid does not bring about crystallization, and the solution may even be stirred with a glass rod which has been heated to redness without bringing about the change (Löwel). According to Violette and Gernez this crystallization is only effected by the presence of a crystal of the same substance as that in solution, and which, therefore, possesses the same crystalline form and contains the same amount of water of crystallization. Gernez has also shown that microscopic crystals of sodium sulphate are always present in the air. Jeannel, on the other hand, found that when a saturated solution of sodium acetate is brought into contact with any solid body such as paper, and when a similar solution of sodium tartrate is stirred with a dry clean glass rod, crystallization occurs. Hence he assumes that saturated solutions when heated, form peculiar hydrates, and that these remain unaltered when the temperature is lowered, but that vibration or the presence of a crystal of the salt is sufficient to bring about their decomposition.

When two salts which do not act chemically upon one another are dissolved in water, the quantity of each which is dissolved is as a rule less than if they were dissolved separately. Thus, for instance, if a concentrated solution of common salt, NaCl , be shaken up with solid sal-ammoniac, NH_4Cl , a large proportion of the latter salt dissolves whilst crystals of common salt separate out, whereas if common salt be added to a concentrated solution of sal-ammoniac a portion of the latter salt separates out. Some few salts dissolve in equal quantity in water whether alone or in combination with another salt, but in the latter case less of the second salt is dissolved than would be dissolved in pure water. The relative quantity depends upon whether the two salts are shaken up together with water, or whether the one is dissolved in a saturated solution of the other, or *vice versa*. Thus, at $18^\circ 7$, 100 parts of water dissolved the following quantities of sal-ammoniac and saltpetre:—¹

¹ Karsten, *Philosophie der Chemie*.

	Saltpetre in Sal-ammoniac solution.	Sal-ammoniac in Saltpetre solution.	Both salts dissolved together.
NH_4Cl . . .	37.98 . . .	44.33 . . .	39.84
KNO_3 . . .	37.68 . . .	30.56 . . .	38.62

Many salts, both among those which are soluble and those which are insoluble in water, are found to dissolve in alcohol, whereas other salts which are easily soluble in water are difficultly soluble or insoluble in alcohol. For this reason the latter are separated out in the form of finely divided crystals when alcohol is added to their aqueous solution. This property is frequently employed in quantitative analysis, and was first proposed for this purpose by Bergman in the year 1778.

GENERIC PROPERTIES OF SALTS.

The generic properties of salts and their modes of preparation have been mentioned in the first volume under the several acids. The most important of these properties may now be recapitulated.

Chlorides.—The greater number of the chlorides are solid bodies: a few, such as stannic chloride, SnCl_4 , and titanium chloride, TiCl_4 , are liquids. Some of the solid chlorides melt at a comparatively low temperature, and, like mercuric chloride, HgCl_2 , and antimony chloride, SbCl_3 , are easily volatilized. The majority however can only be vaporized at a red heat or at a still higher temperature. Some, such as gold trichloride, AuCl_3 , and platinum tetrachloride, PtCl_4 , decompose into their elementary constituents when heated. The chlorides which are insoluble in water are silver chloride, AgCl , mercurous chloride, Hg_2Cl_2 , cuprous chloride, Cu_2Cl_2 , platinum dichloride, PtCl_2 , and palladium dichloride, PdCl_2 . Lead chloride and thallium chloride are difficultly soluble in cold water, although they dissolve readily in hot. All the soluble chlorides produce with silver nitrate solution a curdy white precipitate of silver chloride which is easily soluble in ammonia and is re-precipitated from this ammoniacal solution by nitric acid. When treated with concentrated sulphuric acid the chlorides yield hydrochloric acid; a few of the insoluble chlorides are, however, scarcely acted upon by this substance.

Bromides.—The metallic bromides resemble most closely the corresponding chlorides. Silver bromide is however less soluble in ammonia than silver chloride. The bromides when treated

with concentrated sulphuric acid are decomposed with evolution of hydrobromic acid, free bromine, and sulphur dioxide. Free chlorine liberates bromine from a solution of a bromide.

Iodides.—This group of salts possesses great analogy with the corresponding chlorides and bromides. It is distinguished from them by the fact that silver iodide is insoluble in ammonia and that concentrated sulphuric acid decomposes the iodides with liberation of iodine and sulphur dioxide. Mercuric iodide is an insoluble scarlet powder, whilst lead iodide forms a yellow precipitate. This latter dissolves in large quantities of boiling water, and is again deposited on cooling in bright golden flakes. The soluble iodides are decomposed by chlorine, bromine, and nitrous acid, with liberation of iodine.

27 Cyanides.—These compounds are classed with the foregoing, as they resemble them very closely in their properties, and not unfrequently occur together with them. The cyanides of the alkali metals, those of the alkaline earths, and mercuric cyanide, are soluble in water. The other metallic cyanides are insoluble in water, but dissolve in cyanide of potassium with formation of double cyanides. Most cyanides are decomposed by dilute acids with evolution of hydrocyanic acid, whilst all the soluble simple cyanides yield with silver nitrate a curdy precipitate of silver cyanide, AgCN , which is easily soluble in ammonia. This salt is distinguished from silver chloride, inasmuch as when warmed with hydrochloric acid, hydrocyanic acid is given off, and when heated it is decomposed, leaving a residue of metallic silver.

Fluorides.—The metallic fluorides are distinguished by many reactions from the foregoing compounds. The fluorides of silver and tin are easily soluble in water, those of the alkali metals and of iron difficultly soluble, and the other fluorides insoluble in water. Concentrated sulphuric acid decomposes these salts, hydrofluoric acid being evolved, and the presence of which can be readily recognised by its power of etching upon glass. The fluorides of the negative or acid-forming elements possess the very remarkable power of acting towards the fluorides of the positive elements as acids, thus giving rise to a series of peculiar salts known as the double fluorides; thus:—

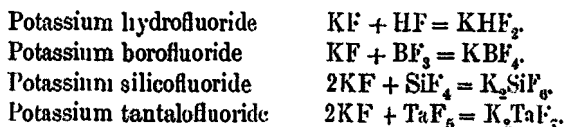

Hypochlorites.—The salts of hypochlorous acid are almost unknown in the free state, as they occur mixed with chlorides. Their solutions bleach organic colouring matters slowly, but on the addition of hydrochloric acid the bleaching is rapidly effected, inasmuch as chlorine is set at liberty; thus:—

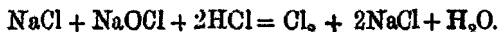

This reaction serves to detect the presence of these bodies.

Chlorates.—All the chlorates are soluble in water. The most important of these salts is potassium chlorate, and this is one of the least soluble. When a solid chlorate is acted upon by strong sulphuric acid a yellow explosive gas, ClO_2 , is given off, and a peculiar odour, which at the same time resembles that of chlorine and that of burnt sugar. A few drops of indigo solution added together with dilute sulphuric acid to the solution of a chlorate are not decolorized, but if sulphurous acid or sodium sulphite is gradually added the blue colour is discharged; this is due to the formation of hypochlorous acid, thus:—

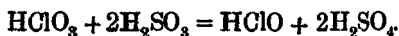

Perchlorates.—These salts are also all soluble in water, and the least soluble is the potassium salt. On the addition of sulphuric acid no explosive or strongly smelling gas is evolved; their acid solution does not bleach indigo even on the addition of a sulphite.

The salts of these oxyacids of chlorine all yield oxygen on heating and leave a residue of a chloride.

28 *Sulphates.*—The sulphates as a rule are soluble in water and crystallizable. Barium sulphate is insoluble in water; the sulphates of strontium and lead are almost insoluble in water, whilst calcium sulphate requires 500 parts, and silver sulphate 200 parts of water for solution. The metals of the alkalis form normal and acid sulphates, the metals of the alkaline earths and magnesium yield only normal sulphates, whilst many other metals form soluble normal salts as well as more or less insoluble basic sulphates. Many sulphates possess the property of forming crystallizable double salts. This is especially the case with the sulphates of the isomorphous metals of the magnesium group, which yield compounds with the sulphates of the alkali metals having the general formula $\overset{\text{I}}{\text{M}}\text{SO}_4 + \overset{\text{II}}{\text{M}}_2\text{SO}_4 + 6\text{H}_2\text{O}$.

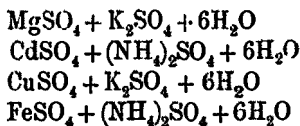

Another important group of the double sulphates is that of the *alums*, which have the general formula $\overset{\text{VI}}{\text{M}}_2(\text{SO}_4)_3 + \overset{\text{I}}{\text{M}}_3\text{SO}_4 + 24\text{H}_2\text{O}$.

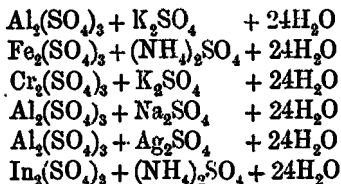

The most delicate reagent for the detection of sulphuric acid and its soluble salts is a solution of barium chloride, which, even in the most dilute solutions, throws down a white precipitate of barium sulphate insoluble in dilute hydrochloric acid. Hydrofluosilicic acid and selenic acid are also precipitated by barium chloride in presence of free hydrochloric acid, but these precipitates can be readily distinguished. Barium sulphate when heated before the blowpipe on charcoal with sodium carbonate yields sodium sulphide, which, brought on a clean silver surface in contact with a drop of dilute acid, produces a brown stain of silver sulphide. Barium selenate indeed yields a similar reaction, but if this salt be boiled with concentrated hydrochloric acid, chlorine is evolved, and sulphurous oxide passed into the solution yields a red precipitate of selenium. Barium silicofluoride is not precipitated in very dilute solutions, and does not yield a black stain with silver when treated as above described.

Sulphites.—The normal and acid sulphites of the alkali metals are soluble in water. The other normal salts are very difficultly soluble or almost insoluble, but most of them dissolve in a solution of sulphurous acid. Lead sulphite, PbSO_3 , is insoluble in water, but very slightly soluble in sulphurous acid. When a sulphite is treated with sulphuric acid or hydrochloric acid it is decomposed with formation of sulphurous acid or sulphur dioxide, and this may be readily detected by its pungent odour. When a sulphite is warmed with dilute hydrochloric acid and zinc, sulphuretted hydrogen is evolved, and in this way minute quantities of a sulphite may readily be detected.

Chlorine, nitric acid, and other oxidizing agents convert the sulphites into the corresponding sulphates.

Thiosulphates.—The soluble thiosulphates may be readily detected by the fact that the solution when acidified with hydrochloric acid remains transparent and odourless, but sooner or later, according to the degree of concentration, becomes milky, owing to the deposition of sulphur, and gives off a smell of sulphur dioxide. If silver nitrate be added to a solution of a thiosulphate, a white precipitate of silver thiosulphate, $\text{Ag}_2\text{S}_2\text{O}_3$, is first formed, and this dissolves again until an excess of silver nitrate is added. After a short time, however, and especially on warming, the solution becomes of a black colour from the formation of silver sulphide, Ag_2S ; thus:—

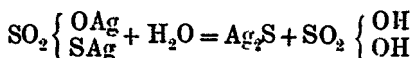

29 Nitrates.—The normal nitrates are all soluble in water, and are as a rule crystallizable. If the solution is not too dilute it yields on treatment with sulphuric acid and metallic copper, brown-red vapours. The detection of nitric acid or a nitrate in still more dilute solution is effected by the reaction with ferrous sulphate or by that of aniline or brucine. (See par. 229, Vol. I.) The nitrates are all decomposed on ignition, those of the alkali metals and silver yield oxygen and a nitrite; other nitrates, such as lead nitrate, yield a metallic oxide and nitrogen peroxide.

Nitrites.—These salts may easily be distinguished from the nitrates by the fact that on the addition of a stronger acid, brown-red vapours are evolved, whilst their aqueous solution gives a brown-black colouration on the addition of protosulphate of iron and acetic acid. (See par. 241, Vol. I.)

Phosphates.—The commonly occurring phosphates are the salts of orthophosphoric acid. The normal orthophosphates of the alkali metals are, with the exception of the lithium salt, easily soluble in water; the remaining orthophosphates are insoluble. The constitution of the phosphates and their most important reactions have been fully described in Vol. I. pars. 295—302.

Arsenates.—These salts are isomorphous with the corresponding phosphates. These two classes of salts exhibit in their general character the strongest possible similarity. As a distinguishing test between the two series, the reaction with silver nitrate may be mentioned. With an orthophosphate this pro-

duces a light canary yellow precipitate, whilst the arsenate of silver forms a brownish-red coloured precipitate. The acidified solution of a phosphate is not altered by sulphuretted hydrogen, whereas that of an arsenate gradually becomes of a yellow colour from the separation of the yellow arsenic trisulphide. An arsenate, moreover, when heated before the blowpipe on charcoal, yields the well-known alliaceous odour of arsenic, no such smell being observed in the case of a phosphate.

The generic properties of the arsenites, borates, silicates, carbonates, &c., will be found in Volume I.

SULPHIDES AND SULPHO-SALTS.

30 The compounds of the metals with sulphur correspond generally with the oxides—and they may be classed as I. Basic Sulphides; II. Persulphides; III. Acid-forming sulphides. The basic sulphides of the alkali metals and some of those of the alkaline-earth metals are soluble in water, form soluble hydro-sulphides, possess an alkaline reaction, and combine with acid-forming sulphides to form Sulpho-salts, some of which are soluble and others insoluble in water, and possess an analogous composition to the corresponding oxygen salts.

Oxygen-Salts.

Potassium carbonate, K_2CO_3
 Sodium pyrophosphate, $Na_4P_2O_7$
 Potassium metarsenate, $KAsO_3$
 Potassium orthoarsenate, K_3AsO_4

Sulpho-Salts.

Potassium thiocarbonate, K_2CS_3
 Sodium pyrothiophosphate, $Na_4P_2S_7$
 Potassium metathioarsenate, $KAsS_3$
 Potassium orthothioarsenate, K_3AsS_4 .

Selenium and tellurium form similar compounds. The more important compounds of the metals with the other non-metallic elements will be mentioned hereafter.

ALKALI METALS.

Potassium.

Sodium.

Lithium.

Rubidium.

Cæsium.

31 The word *alkali* was used by Geber as the name for a soluble salt obtained by the lixiviation of the ashes of sea-plants. We also find the same word employed to designate the carbonate of potash obtained by a similar treatment of the ashes of land-plants. The difference between the alkalis, potash and soda, was at that time not understood, and in order to distinguish them from the carbonate of ammonia, the volatile alkali, they were both termed the fixed alkali. The distinction between the mild and caustic alkalis had long been known, and the mode of converting the former into the latter by boiling their solutions with lime was a well-recognised process. In the Historical Introduction (see Vol. I. p. 15) we have seen that Black, in the year 1756, was the first to explain this change, as he proved that the mild alkalis contained fixed air or carbon dioxide.

The first clear distinction between the two alkalis, potash and soda, appears to have been made by Duhamel in the year 1736, although Stahl pointed out that the alkali contained in common salt is different from that contained in wood-ashes, and this difference was indicated by the first being termed the mineral, and the second the vegetable alkali. Marggraf showed in 1759 that the salts of the two alkalis possess totally distinct properties, and that whilst those of the common alkali tinge the flame of a spirit-lamp violet, those containing the base of common salt impart to flame a yellow colour. It was, however, soon afterwards pointed out by Klaproth that the vegetable alkali potash was contained in several minerals, such as leucite, and then the special name *potash* in English, *potasse* in French, and

kali in German, was given to this particular alkali. Klaproth suggested for the mineral-alkali the name *natron*, the English equivalent for which is *soda*, and the French *soude*. All these names had formerly been used indiscriminately for any alkali.

Up to the year 1807 the alkalis were considered to be simple substances. Lavoisier had indeed expressed a view that these bodies probably contained oxygen, owing to their analogy with other well-known metallic oxides, but Davy was the first to isolate the metals.

POTASSIUM

K = 39.04.

32 The discovery of this metal is described as follows by Davy.¹ "A small piece of pure potash which had been exposed for a few seconds to the atmosphere, so as to give conducting power to the surface, was placed upon an insulated disc of platina, connected with the negative side of the battery of the power of 250 of 6 and 4, in a state of intense activity; and a platina wire, communicating with the positive side, was brought in contact with the upper surface of the alkali. The whole apparatus was in the open atmosphere.

"Under these circumstances a vivid action was soon observed to take place. The potash began to fuse at both its points of electrization. There was a violent effervescence at the upper surface; at the lower, or negative surface, there was no liberation of elastic fluid, but small globules having a high metallic lustre, and being precisely similar in visible characters to quicksilver, appeared, some of which burnt with explosion and bright flame, as soon as they were formed, and others remained, and were merely tarnished, and finally covered by a white film which formed on their surfaces. These globules, numerous experiments soon showed to be the substance I was in search of, and a peculiar inflammable principle the basis of potash. I found that the platina was in no way connected with the result, except as the medium for exhibiting the electrical powers of decomposition, and a substance of the same kind was produced when pieces of copper, silver, gold, plumbago, or even charcoal were employed for completing the circuit.

"The phenomenon was independent of the presence of air.

¹ *Phil. Trans.* 1808.

I found that it took place when the alkali was in the vacuum of an exhausted receiver."

To this metal Davy gave the name of potassium. Soon after Davy's discovery, Gay-Lussac and Thénard¹ showed that the metal might be obtained in greater quantity by decomposing potash by means of metallic iron at a white heat. For this purpose iron turnings or wire were heated to whiteness in a gun-barrel covered with clay, and melted potash allowed to pass slowly over the ignited iron. The iron took up the oxygen of the hydrate, whilst potassium and hydrogen were set free. The potassium passed over in the state of vapour, and was condensed in a copper vessel containing naphtha. A still better method is that suggested by Curadau;² it consists in the decomposition of the potash by means of charcoal at a white heat.

Davy's discovery of the compound nature of the alkalis attracted universal attention, and chemists throughout Europe were occupied with a repetition of his experiments, and an examination of the remarkable properties of the singular metals which can thus be obtained. So singular indeed are these properties, that many chemists denied to these substances the name of metal, and by some they were considered to be compounds of hydrogen, this view being apparently borne out by the evolution of hydrogen when these metals are thrown into water. A more accurate examination, however, of the properties of these substances proved them to be of a truly metallic nature.

Sources of Potassium.—Potassium is found in nature, in a state of combination, widely distributed. It occurs as a constituent of many silicates, forming from 1.7 to 3.1 per cent. of the granite composing the earth's solid crust. Amongst the silicates which contain potash as an essential constituent, may be mentioned potash-felspar, or orthoclase, leucite, and analcime. Pure chloride of potassium or silvite, KCl , is found in considerable deposits, together with carnallite, $KCl + MgCl_2 + 6H_2O$, in the neighbourhood of Stassfurt in Germany. This same salt and other potash compounds occur in small quantity in the water of the ocean, and in that of many lakes such as the Dead Sea, as well as in mineral waters and in ordinary spring water. Chloride of potassium is also found in cubic crystals surrounding the fumeroles of Vesuvius. All fruitful soil contains potassium compounds. These are taken up by the rootlets of the plant,

¹ *Ann. de Chim.* lxx. 325.

² *Ann. de Chim.* lxxvi. 97.

as no vegetable growth can flourish without this substance. It has been shown by Way, that soil possesses the power of absorbing potash salts, whilst soda salts pass through it unabsorbed. The form in which the potash is contained in most soil is that of a salt of an organic acid; this becomes converted into carbonate by ignition. Potash is the essential alkali contained in the animal body, the soda salts being rapidly eliminated (Liebig).

The potash which sheep draw from the land is excreted in large quantity from the skin in the sweat, termed by the French *suint*. No less than one-third of the weight of raw merino wool consists of this material.

33 *Preparation of Metallic Potassium.*—The method first proposed by Curadau, and brought into a practical form by Brunner, has been much improved by Wöhler, and especially by Donny and Mareska.¹ This process depends upon the fact that at a white heat carbon reduces carbonate of potassium, as follows:—

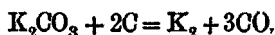

An intimate mixture of charcoal and potassium carbonate is obtained by igniting crude tartar (acid potassium tartrate) in a covered iron crucible; the porous mass is rapidly cooled by dipping the crucible into cold water, and the charred mass introduced into an iron bottle. It has been usual to place the mixture in a wrought iron mercury-bottle, connected with a copper receiver by a short iron tube, as shown in Fig. 2.

Recently, malleable iron tubes coated with clay have been preferably employed as retorts. In the preparation of the metal potassium, according to Brunner's original method, serious explosions sometimes occurred, owing to the fact that at a very high temperature the metallic potassium unites with the carbon monoxide generated at the same time, to form a peculiar black compound, $K_2C_2O_2$, which is excessively explosive. By rapidly cooling the vapour of the potassium as it is produced, the formation of this compound may be prevented. This rapid cooling of the vapour is effected by using the condenser, first suggested by Mareska and Donny, shown in Fig. 3. It consists of two pieces of cast-iron *d's*, which can be clamped together so as to form a shallow box about a quarter of an inch deep, ten to twelve inches long, and four to five inches in width. The socket at the one end fits on to the short tube placed in the neck of the

¹ *Ann. Chem. Phys.* [3], xxxv. 147.

bottle, or at the closed end of the retort, whilst the open end permits a free passage to the gases or vapours given off in the reaction. The object of this flattened condenser is to ensure the rapid cooling of the vapour of the metal, and thus prevent the formation of the explosive compound with carbon monoxide. The above-mentioned reduction only takes place at a white heat, and hence it is necessary to prevent the oxidation of the iron of the retort by covering it with a coating of fire-clay. As soon as this temperature is reached the vapour of the metal begins to appear at the open end of the tube. The receiver is then

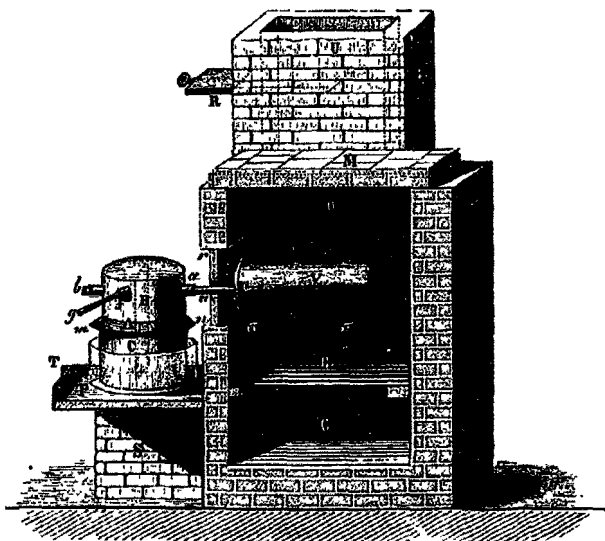

FIG. 2.

adjusted to the end of the tube as shown in Fig. 4, and the metal begins to condense and drops out in the liquid state into a vessel filled with rock-oil placed beneath the receiver, which does not require to be artificially cooled. Should any deposit or obstruction occur in the tube, this must at once be removed by a red-hot rod thrust into it. It is found in practice that about half the theoretical quantity of metal is obtained.

Potassium can be prepared on the small scale by the electrolysis of potassium cyanide. This salt is melted and then allowed to cool, so that a solid crust is formed; a current from three or

four Bunsen's elements is then allowed to pass through the molten salt from poles made of gas carbon.¹

A better method of obtaining potassium by electrolysis is that proposed by Matthiessen.¹ For this purpose a mixture of potassium chloride and calcium chloride in equal molecular proportions, which melts at a much lower temperature than the potassium chloride alone, is fused in a small porcelain crucible over a lamp, two carbon poles connected with six to eight Bunsen's elements being dipped into the fused salt. The flame of the lamp is then so adjusted that the portion of salt around the negative pole becomes solid, whilst around the positive pole the mixture is liquid, thus allowing the free escape of the chlorine. After the



FIG. 3.

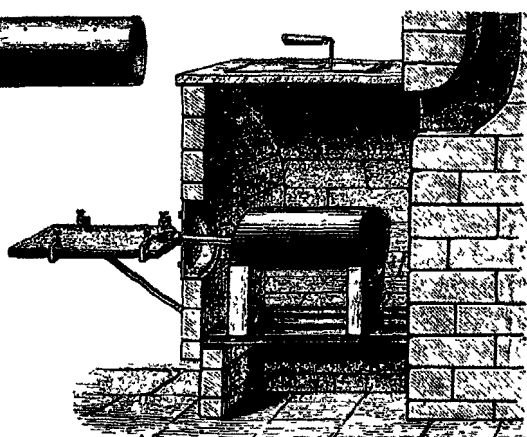
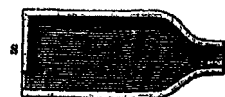

FIG. 1.

current has passed through for about twenty minutes in this way the crucible is allowed to cool, and opened under rock oil, when a considerable quantity of pure potassium is found around the negative pole, no calcium being deposited.

34 *Properties*.—Potassium is a silvery white lustrous metal having a specific gravity of 0·875 at 13° (Baumhauer),³ and it is therefore lighter than all other metals, with the single exception of lithium. It is brittle at 0° and possesses a crystalline fracture; at 15° it becomes soft like wax, and may be easily cut with a knife, and the two clean surfaces of the metal may be

¹ Linnemann, *Journ. Pract. Chem.* lxxiii. 413.

² *Chem. Soc. Journ.* viii. 30.

³ *Ber. Deutsch. Chem. Ges.* vi. 655.

welded together like red-hot iron. It melts at $62^{\circ}5$ (Bunsen), forming a liquid closely resembling mercury in its appearance. Potassium may be easily obtained in the crystalline form. For this purpose some of the metal is melted in a glass tube filled with coal-gas; as soon as the mass begins to solidify the tube is quickly turned round and the portion of metal still remaining liquid is poured off from the crystals; these form quadratic octahedra having a greenish-blue colour.¹ Potassium dissolves in liquid ammonia, yielding a deep blue solution, and if the ammonia be allowed to evaporate, metallic potassium separates out unchanged.²

At a red-heat potassium boils, emitting a beautiful green-coloured vapour exhibiting a characteristic channelled-space absorption-spectrum (Roscoe and Schuster). The specific gravity of potassium vapour is not greater than 45. Hence we conclude that the molecule of potassium vapour consists of two atoms, and that the molecular weight of the metal is 78 (Dittmar and Dewar).³ The green colour of potassium vapour can be readily shown by evaporating a small portion of the metal contained in a wide glass tube three decm. in length, through which a current of dry hydrogen gas is passed. On heating the metal, the tube becomes filled with splendid green-coloured vapour, condensing on the cooler parts of the tube in the form of a bright metallic mirror. When the hydrogen, which issues from the end of the tube, is lighted the flame is tinged with the characteristic violet colour of potassium. Next to caesium and rubidium, potassium is the most electro-positive metal. In perfectly dry and pure air it does not undergo any change, but in ordinary air the clean surface of the metal soon becomes converted into caustic potash and potassium carbonate. The oxidation of a newly-cut surface of potassium is attended in the dark with luminosity (Baumhauer). Oxidation takes place so quickly when the metal is exposed to the air in thin layers, that sometimes ignition occurs, and the metal burns with its characteristic violet flame. When heated in the air to its point of volatilization, it at once bursts into flame.

When thrown upon water potassium decomposes the water with great violence, sufficient heat being generated to ignite the hydrogen which is evolved, and which burns with the violet potassium flame. The molten globule swims about on the sur-

¹ C. E. Long, *Chem. Soc. Journ.* xiii. 122.

² Seeley, *Chem. News*, xxiii. 169.

³ *Proc. Roy. Soc.* xxi. 203.

face of the water, becoming gradually smaller, and leaving at last a globule of fused potash, which causes an explosive burst as soon as its temperature sinks low enough to allow it to come actually in contact with the water. This phenomenon may be illustrated on a larger scale by the following experiment. A piece of silver weighing 150 grams, and fastened to a copper wire, is heated to bright redness in a gas flame and then quickly dipped into a large beaker-glass full of cold water. The metal remains quietly in the water for some seconds, and then a violent explosion occurs, the water is thrown about in all directions, and not unfrequently the beaker-glass is broken. The explanation of the phenomenon is the same as of that of a drop of water floating on a red-hot surface; there is no real contact between the hot metal and the water, a film of steam existing between them. But as soon as the temperature of the metal sinks below a certain point the water is brought into actual contact with it, a sudden evolution of steam takes place, and an explosion is the result.

Potassium acts as a powerful reducing agent, and hence it has been largely employed for the preparation of such substances as boron and silicon from their oxides, and magnesium, aluminium, and other metals from their chlorides. The cheaper metal, sodium, is now, however, generally used for this purpose. Potassium also decomposes nearly all gases which contain oxygen, and hence it is used in some cases to ascertain the composition of gases.

POTASSIUM AND HYDROGEN.

POTASSIUM HYDROGENIDE, K_4H_2 .

35 Potassium, when heated to incipient redness in pure hydrogen gas, absorbs about one-fourth of the volume it would have evolved in contact with water (Gay-Lussac and Thénard). A grey powder, possessing no metallic lustre and not melting below a red heat, is thus produced. This compound, in which the hydrogen is contained in the form of hydrogenium (Vol. I. par. 39), has been recently examined by Troost and Hautefeuille.¹ They found that potassium when heated to 200° slowly absorbs

¹ *Ann. Chim. Phys.* [5], ii. 273.

126 volumes of hydrogen gas, whilst at 300-400° this absorption takes place very rapidly. A lustrous brittle crystalline compound is thus formed which take fire on exposure to the air,

POTASSIUM AND OXYGEN.

This metal forms two oxides :—

Potassium monoxide, K_2O .

Potassium peroxide, K_2O_2 .

36 The first is a powerfully basic oxide, whilst the second belongs to the class of peroxides. In addition to these, a lower oxide appears to exist. This forms the blue substance obtained on exposing thin layers of potassium to the action of a small quantity of air. The same blue crust is also seen when the bright metallic mirror described on page 60 is allowed to come in contact with the air, this in its turn slowly giving place to a film of the white oxide as the oxidation proceeds.

POTASSIUM MONOXIDE, K_2O .

When potassium is heated in dry air it takes fire and burns with formation of the two oxides. This mixture when strongly heated evolves oxygen, leaving a residue of the monoxide (Davy). The same oxide is formed when caustic potash is heated with potassium :—

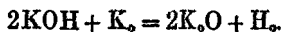

Neither of these processes, however, yields a pure compound. For this purpose potassium is melted, and, without further heating, the requisite volume of pure dry air is led over it. The potassium separates out into a thin film which takes fire and burns, forming a white fume of the monoxide.¹

Potassium monoxide is a grey brittle mass, having a conchoidal fracture; it is very deliquescent and caustic; it combines energetically with water, becoming even red-hot when moistened with it, potassium hydroxide being formed (Berzelius).

¹ Kühnemann, *Chem. Centr.* 1863, 491.

POTASSIUM HYDROXIDE, OR CAUSTIC POTASH, KOH.

This compound, generally known by its old name of caustic potash, was considered to be an oxide of potassium, but Darcet,¹ in the beginning of 1808, showed that ignited caustic alkali contains some other ingredient in addition to oxygen and the metal. He believed that this ingredient was in all probability water, inasmuch as the calculated quantity of alkali contained in the carbonate neutralises more acid than the same quantity of the ignited caustic alkali. From this time forward caustic potash was considered to be a compound of potassium oxide and water, and it was not until a much later period that it was recognised to be an *hydroxide*, or a compound which is derived from water by the replacement of a portion of the hydrogen by a metal.

In order to obtain caustic potash in the perfectly pure state, the metal or the oxide is best dissolved in water. The substance is however generally prepared by decomposing a dilute solution of potassium carbonate with slaked lime. For this purpose, one part by weight of potassium carbonate is dissolved in twelve parts of water, the solution placed in an iron or silver vessel provided with a lid, heated to the boiling point, and then milk of lime gradually added until a portion of the filtered liquid evolves no carbon dioxide when treated with an acid. The solution is allowed to settle, and the clear liquid drawn off into a well-stoppered vessel. This is then evaporated in a silver basin until the hydroxide begins to volatilize. In order to ensure the complete separation of the carbonic acid from the potash, not less water than that mentioned must be used, and the water which evaporates from time to time must be renewed, for when only four parts of water are present to one part of potassium carbonate no decomposition takes place. A concentrated solution of caustic potash is found to decompose carbonate of calcium (Liebig). Commercial caustic potash is prepared in this way. It is usually cast in the form of sticks; this contains more or less water as well as all the impurities which the carbonate of potash contained, especially alumina, potassium chloride, potassium sulphate, and potassium silicate.

In order to purify the commercial substance it may be dissolved in pure alcohol, the insoluble matters allowed to deposit, and the clear solution boiled down to dryness in a silver basin

¹ *Ann. Chim.* lxxviii. 175.

(*Potasse à l'alcool*, Berthollet). By this method it may be obtained free from sulphate and alumina, but it always contains traces of potassium chloride, potassium carbonate, and potassium acetate, which latter substance is formed by the action of caustic potash on alcohol.

Pure caustic potash may also be obtained by adding powdered sulphate of potash to a hot concentrated solution of barium hydroxide (baryta-water) until a small quantity of sulphate of potassium remains in excess; this is then removed by a careful addition of baryta-water. The clear solution poured off from the insoluble barium sulphate is now evaporated in a silver basin, any baryta which remains in solution being deposited in the form of carbonate from contact with the carbonic acid of the air.¹

Wöhler's process for obtaining pure caustic potash consists in decomposing pure potassium nitrate by metallic copper at a red heat. For this purpose one part of saltpetre and from two to three parts of thin copper foil are arranged in alternate thin layers in a covered copper crucible and exposed for several hours to a red heat. On cooling, the mass is treated with water, the liquid allowed to stand in a tall cylindrical stoppered vessel, and the clear liquid then evaporated as before.²

Properties.—Pure caustic potash is a hard white brittle substance, often exhibiting a fibrous structure, melting below a red-heat to a clear oily liquid, and volatilizing in the form of white vapours when more strongly ignited. The vapour of this substance decomposes, at a white heat, into potassium, hydrogen, and oxygen; this decomposition explains, according to Deville, the formation of potassium by Gay-Lussac's method. When caustic potash is heated with silica or boron trioxide, potassium silicate or potassium borate is formed with the evolution of water.

Caustic potash rapidly absorbs carbonic acid and moisture from the air, and dissolves, with evolution of heat, in water. According to Bineau, one part of water dissolves 2.13 parts of caustic potash. When the concentrated aqueous solution is cooled, the hydrate $\text{KOH} + 2\text{H}_2\text{O}$ crystallizes in transparent colourless acute rhombohedrons.

The aqueous solution of caustic potash, sometimes known as *potash lye*, possess an acrid taste and a peculiar nauseous odour;

¹ Schubert, *Journ. Pract. Chem.* xxvi. 117.

² *Ann. Chem. Pharm.* lxxxvii. 373.

it acts as a powerful cautery, quickly destroying both animal and vegetable substances. For this reason its solution cannot be filtered except through glass or sand, and it is best clarified by subsidence. The following table gives the specific gravity at 15° of solutions of potash of varying strength calculated by Gerlach¹ from the experiments of Tünnermann and Schiff:—

Per cent. of KOH.	Specific gravity.	Per cent. of KOH.	Specific gravity.
1 . . .	1·009	40 . . .	1·411
5 . . .	1·041	45 . . .	1·475
10 . . .	1·083	50 . . .	1·539
15 . . .	1·128	55 . . .	1·604
20 . . .	1·177	60 . . .	1·667
25 . . .	1·230	65 . . .	1·729
30 . . .	1·288	70 . . .	1·790
35 . . .	1·349		

The *liquor potassæ* of the Pharmacopœia contains about 5 per cent. of the hydrate KOH, and has a specific gravity of 1·508. Caustic potash is largely used in the form of a lye for absorbing carbonic acid in both organic and inorganic analysis. The solid is also largely used as a caustic for surgical purposes. It absorbs moisture very rapidly from the air, and may, therefore, be employed for drying certain gases and liquids, especially organic substances which do not dissolve it and are not acted upon by it. The chief use, however, of caustic potash is for the manufacture of soft soap. The soap-maker formerly prepared his lye by lixiviation of wood-ashes; the solution thus obtained was causticized by boiling with milk of lime. At the present day the crude potashes are employed for this purpose.

POTASSIUM PEROXIDE, K_2O_2 .

37 This oxide was discovered by Gay-Lussac and Thénard. It is best obtained by heating potassium in dry air or oxygen. The metal takes fire at a temperature of from 60° to 80°, and when the surface is kept clean, burns to peroxide. In order to obtain the oxide in the pure state, clean potassium must be moderately heated, first in a current of dry air, and then in dry oxygen. If the metal is at once exposed to oxygen, great heat is evolved and

¹ *Zeitsch. Anal. Chem.* viii. 279.

the glass is attacked. According to Vernou Harcourt,¹ it is best to bring clean dry potassium into a flask containing dry nitrogen, in which it is melted. The nitrogen gas is then gradually displaced by air; the grey film which covers the molten metal is seen to change to a deep blue; then a point is reached at which the rapid absorption of oxygen begins. Gradually, as the oxidation proceeds, the metallic coating of the inner surface of the bulb changes to a dead white; this, however, after a while assumes a yellow colour, due to the formation of the tetroxide.

Potassium tetroxide is a dark chrome yellow-coloured powder which fuses at a point higher than caustic potash, forming a black liquid which, when the temperature falls, crystallizes with shining tabular surfaces; at a white heat it is decomposed into potassium monoxide and oxygen. Thrown on to water it dissolves with considerable evolution of heat, forming caustic potash, hydrogen peroxide, and free oxygen. Carbon monoxide acts upon the peroxide at a temperature somewhat below 100° with the formation of potassium carbonate, a volume of oxygen equal to that of the carbon monoxide employed being liberated, thus:—



Phosphorus and sulphur act violently upon the peroxide with formation of phosphate and sulphate of potash. When metals such as potassium, arsenic, antimony, and zinc are heated with this compound, they are oxidized with evolution of light and heat, whilst several metals such as bismuth, lead, iron, and silver undergo oxidation without the phenomenon of incandescence.

POTASSIUM SALTS.

38 Potassium Chloride, KCl, is a substance closely resembling rock-salt. Indeed, in earlier times no distinction was drawn between these two compounds. It occurs in sea-water as well as in that of many mineral springs, and forms the chief portion of the Stassfurt potash-salt. This salt exists in a bed 20 to 30 meters in thickness, lying above the deposit of rock-salt, and consisting chiefly of carnallite, $\text{KCl}, \text{MgCl}_2 + 6\text{H}_2\text{O}$, and kieserite, $\text{MgSO}_4 + \text{H}_2\text{O}$, interspersed with layers or veins of tachydrate, $\text{CaCl}_2, 2\text{MgCl}_2 + 12\text{H}_2\text{O}$; boracite, $2\text{Mg}_3\text{B}_5\text{O}_{15} + \text{MgCl}_2$; kainite, $\text{K}_2\text{SO}_4, \text{MgSO}_4, \text{MgCl}_2 + 6\text{H}_2\text{O}$; and lastly sylvine, KCl

¹ *Quart Journ. Chem. Soc.*, xiv. 247.

These two latter appear to be formed by the action of water upon the preceding compounds. In these minerals a small quantity of the potassium chloride is replaced by potassium bromide, and crystals of anhydrite, CaSO_4 , are found in the kieserite beds, whilst in the lower portion of the deposit polyhalite, $2\text{CaSO}_4, \text{MgSO}_4, \text{K}_2\text{SO}_4, + 2\text{H}_2\text{O}$, occurs. The minerals composing this bed are all of them very deliquescent, and their position leads to the inference that the saline deposits at Stassfurt have been formed by the gradual evaporation of an inland sea or salt-water lake. This is rendered more probable by the fact that in the manufacture of sea-salt in the so-called salterns on the Mediterranean coasts similar salts are deposited from the mother liquors. In addition to the deposit at Stassfurt, similar beds have been found at Kulnsz, in the East Carpathians. These potash salts do not occur in the majority of saliferous beds, and this is probably due to the fact that the upper saline strata have in most cases been washed away, whereas in the Stassfurt deposit they have been protected by a water-tight stratum of clay. The mode of manufacture of potassium chloride from these potash salts is identical with that proposed by Balard¹ and Merle² for the preparation of the chloride from sea-water, and by Hermann³ for preparing it from certain mineral springs. These methods depend upon the fact that carnallite, which is more soluble in water than rock-salt or kieserite, is only formed in solutions containing an excess of chloride of magnesium, so that when the salt is dissolved in hot water and the solution cools, the double salt does not separate out, but the more soluble magnesium chloride remains in solution whilst a part of the chloride of potassium crystallizes out. The crude salt is thrown into water into which steam is led, and this solution cooled to 60—70°, when a portion of the sodium chloride, together with a little potassium chloride, separates out; the liquors which are then drawn off deposit on standing about 70 per cent. of the potassium chloride. This is treated with a small quantity of cold water in order to wash out a considerable quantity of the sodium chloride, and, according to the amount of water thus employed, a residue containing 80—95 per cent. of potassium chloride is obtained.

A second method depends upon the fact that carnallite is easily soluble in a hot solution of magnesium chloride, whereas

¹ *Jahresh. Chem. Technol.* 1865, 296.

² *Bull. Soc. Chim.* [2], x. 63.

³ *Journ. Pract. Chem.* lx. 284.

sodium chloride and magnesium sulphate are only slightly soluble in this liquid. The liquors drawn off from the latter salts deposit crystals of carnallite on cooling, which can be separated from the mother liquor and then dissolved in hot water; on cooling crystals of potassium chloride separate out, which only need to be washed with cold water in order to bring them up to 98—99 per cent. The different mother-liquors and washwaters are again worked up for the preparation of the other salts which they contain.¹

39 In the salines on the west and south coasts of France the mother-liquors remaining after the common salt has been deposited, having a specific gravity of 1.22, are preserved in reservoirs during the summer, when a mixture of magnesium sulphate and common salt (*sel miéte*) separates out. The mother liquor from this is evaporated in flat pans and thus converted into carnallite, which is worked up as described.

Potassium chloride crystallizes like sodium chloride, in cubes. It has a cooling saline taste; its specific gravity is 1.995; it melts when strongly heated, and readily volatilizes at a strong red-heat; 100 parts of water dissolve 28.5 parts of potassium chloride at 0°, 33.4 parts at 15°, and 59 parts at 100°.

When potassium chloride is melted in a current of hydrogen gas, or when the fused salt is subjected to electrolysis, a dark blue mass is formed which contains a sub-chloride of potassium, the composition of which has not been satisfactorily ascertained.

Potassium chloride may be used for the preparation of other potassium salts such as the chlorate, the carbonate, and the chromate, and in an impure state it is employed as a fertiliser for artificial manures.

Potassium Bromide, KBr. When bromine is dissolved in caustic potash a mixture of bromide and bromate of potassium is formed. If this mixture be evaporated and gently ignited, the bromate is decomposed, and pure potassium bromide is left. Another method of preparing the salt is by the action of bromine and water on iron filings. The bromide of iron thus formed is decomposed by potassium carbonate. A third method depends on the fact that when bromine water and amorphous phosphorus are brought together, aqueous hydrobromic acid is produced: this may be neutralised with milk of lime, when the insoluble phosphate and phosphite of calcium are thrown down, whilst

¹ See *Ber. über Entwickl. Chem. Industrie*, i. 351.

the soluble calcium bromide remains in solution, and this is then precipitated by potassium carbonate.

Potassium bromide crystallizes in cubes possessing a sharp saline taste, and is readily soluble in water. It serves as a valuable medicine, especially in cases of nervous diseases.

40 *Potassium Iodide*, KI. This salt is prepared in a similar way to the bromide. It crystallizes like the two former salts, in cubes. The crystals are transparent if they are slowly deposited from a somewhat dilute solution, whilst if they are deposited from a hot solution they have an opaque porcelain-like appearance. The crystals possess a sharp taste, and they are very soluble in water. Potassium iodide melts at 639° (Carnelley), and can be easily vaporized at a higher temperature. 100 parts of water dissolve at 0° 127.8, and at 118° .4 the boiling point of a saturated solution, 222.6 parts of the salt, and at intermediate temperatures the solution increases proportionally to the increase of temperature (Mulder). Potassium iodide is sparingly soluble in alcohol and in proportion to the quantity of water present. The commercial iodide of potassium generally possesses an alkaline reaction. In order to obtain it perfectly neutral it must be dissolved in the smallest quantity of water, neutralized with dilute sulphuric acid, the potassium sulphate precipitated by the addition of pure alcohol, and the solution allowed to crystallize (Groves). Potassium iodide is largely used in medicine both for internal and for external application. It is especially used in scrofulous and syphilitic diseases.

Potassium Tri-iodide, KI_3 . This compound is formed by saturating a concentrated solution of potassium iodide with iodine. A brown liquid having a metallic lustre is obtained, and this on evaporation over sulphuric acid yields needle-shaped almost black crystals which possess a metallic lustre. They are very deliquescent, melt at 45° , and are decomposed at 100° into iodine and potassium iodide (Johnson).¹

Potassium Fluoride, KF. This is formed when aqueous hydrofluoric acid is neutralized in a platinum vessel with caustic potash or potassium carbonate, and the solution evaporated down. This salt crystallizes in cubes. It is very deliquescent and has a sharp saline taste. When it is dissolved in aqueous hydrofluoric acid it forms an acid fluoride, KHF_2 , crystallizing in quadratic tables. These melt when heated, and at a dark red heat decompose into potassium fluoride and hydrofluoric acid.

¹ *Journ. Chem. Soc.*, 1877, i. 249.

41 *Potassium Hypochlorite*, KOCl . When chlorine is passed into a dilute cold solution of caustic potash or potassium carbonate a mixture of potassium chloride and potassium hypochlorite is obtained. This substance was first prepared by Berthollet, and the solution, known by the name "Eau de Javelle," was formerly largely used for bleaching purposes (see Vol. I. par. 139). Pure potassium hypochlorite has not yet been prepared.

Potassium Chlorate, KClO_3 . It appears likely that this salt was known to Geber. In one of his works he mentions that he is acquainted with a means of converting muriatic acid into nitric acid, and in his "Continuatio Miraculi Mundi" he mentions a peculiar kind of saltpetre which he had prepared by means of common salt. This was probably chlorate of potash. In like manner Winterl, in 1789, believed that he had converted muriatic acid into nitric acid by strongly heating muriate of lime (calcium chloride) in a retort with black oxide of manganese and leading the product into a receiver containing a small quantity of caustic potash. Higgins also stated in 1786 that by the action of dephlogisticated muriatic acid (chlorine) on the alkalis, a peculiar kind of saltpetre is formed.

About the same time Berthollet was employed in his classical investigation of the action of oxidized muriatic acid (chlorine) on the alkalis, and in 1786 he discovered chlorate of potash, which he, according to the prevailing views, termed hyperoxy-muriate of potash. He obtained it by the action of chlorine upon caustic potash, and he observed at the same time that a large quantity of muriate of potash (potassium chloride) was formed; thus:—

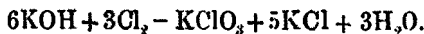

Potassium chlorate was in fact formerly produced on the large scale by this reaction by passing chlorine into a concentrated solution of caustic potash or potassium carbonate. The crystals of potassium chlorate, being only slightly soluble in water, separate out when the solution is cooled, whilst potassium chloride remains in solution. In this reaction only one-fifth of the potash is obtained in the form of chlorate, the rest being transformed into the much less valuable chloride. Hence many improvements in this process have been made. Graham proposed to saturate a mixture of equal molecules of potassium carbonate and dry hydrate of lime with chlorine gas,¹ whilst

¹ *Ann. Chem. Pharm.* xli. 303.

Liebig¹ proposed to saturate with chlorine a mixture of potassium chloride and quick lime, in the proportion of one molecule of the former to three molecules of the latter. These are mixed together with water to form a thin paste. Another process is to evaporate an aqueous solution of 10 parts of bleaching powder to dryness, to dissolve the residue in water, and then to allow the solution, after addition of potassium chloride, to crystallize.

From time to time all these methods have been employed in the manufacture of chlorate of potash. This is now carried on on a large scale, generally as follows:—chlorine is passed into a solution of milk of lime having a specific gravity of 1·04 until the liquid is nearly saturated. The clear solution is evaporated until it has a specific gravity of 1·18 and then potassium chloride added, and the mixture boiled down until a specific gravity of 1·28 is attained. On cooling, crystals of potassium chlorate separate out.² A still simpler plan is to evaporate a solution of bleaching powder with one of potassium chloride.

42 All these methods of preparation depend on the fact that when a solution of chloride of lime is evaporated or boiled down, the calcium hypochlorite contained in the solution is decomposed, calcium chloride and calcium chlorate being formed:—

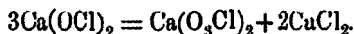

When chloride of potassium is present, a double decomposition takes place, the soluble calcium chloride and difficultly soluble potassium chlorate being formed:—

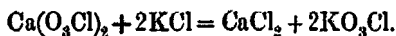

This reaction is not brought about by any greater affinity of potassium to chloric acid than to chlorine, but depends solely upon the fact that potassium chlorate is more sparingly soluble than the other salts contained in solution. In his celebrated *Traité de Statique Chimique*, Berthollet put forward the view that when solutions of two salts containing different acids and bases are mixed, a double decomposition always takes place, and in such a way that the solution, after mixing, contains four salts. Subsequent observations have shown that decompositions of this kind do, in fact, frequently take place. In certain cases this may readily be exhibited. Thus for instance, if a blue solution of

¹ *Ann. Chem. Pharm.* li. 307.

² *Langc, Dingler, Polyd. Journ.* clxxxix. 488.

sulphate of copper be mixed with a solution of sodium chloride, a greenish-coloured liquid is produced due to the formation of cupric chloride. This solution contains four salts, cupric sulphate, cupric chloride, sodium sulphate, and sodium chloride. If in such a case one of the newly formed salts is more difficultly soluble than the salts originally mixed, this separates out partially when the solution becomes sufficiently concentrated. If, on the other hand, the salt thus produced is absolutely insoluble in water, a complete double decomposition takes place when the solutions are mixed, as is the case, for instance, when a soluble barium salt is added to a soluble sulphate.

43 Potassium chlorate crystallizes in large transparent monoclinic tables (Fig. 5) which have a glassy lustre and which when

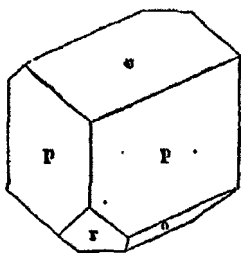

FIG. 5.

they are of certain dimensions exhibit magnificent iridescent colours and emit light when rubbed in the dark. The crystals of potassium chlorate have a feebly acid and cooling taste similar to that of nitre. They melt without decomposition at 334° , and at 352° they begin to decompose with evolution of oxygen.¹ 100 parts of water dissolve at 0°

3.3 parts, and at $104^{\circ}8$, the boiling point of the saturated solution, 60.2 parts of the salt (Gay-Lussac).

Potassium chlorate is used largely for the preparation of oxygen gas. It also acts as a powerful oxidizing agent and is used in the manufacture of lucifer matches and for pyrotechnic purposes. It is largely employed in calico-printing and in the chemical laboratory. In addition, it is a valuable salt for medicinal purposes; in large doses it acts as an irritant poison like nitre and other soluble potassium salts. It used to be given in small doses in cases of scarlet fever, scurvy, and other diseases, as it was believed to act as an oxidizing agent on the blood. It has, however, lately been shown that the whole of the salt passes out undecomposed in the urine. It is still employed for the purpose of allaying inflammation of the throat.

The powerful oxidizing properties of potassium chlorate can be readily exhibited. If a small quantity of the powdered salt be thrown on to glowing charcoal a rapid combustion takes place.

¹ Pohl, *Ber. Wien. Akad.* vi. 587.

If a few grains of this salt together with a few grains of flowers of sulphur are rubbed together in a mortar, loud explosions occur, and if a grain of this mixture be struck with a hammer a loud detonation takes place. If a small quantity of powdered chlorate of potash be carefully mixed by means of a feather with the same quantity of powdered amorphous phosphorus this mixture will take fire when struck even with a slight blow of a glass rod.

Potassium Perchlorate. This salt is best obtained by heating pure potassium chlorate in a porcelain basin until the liquid mass begins to solidify. As soon as a sample of the material becomes only coloured of a light yellow when treated with hydrochloric acid the reaction is complete. The decomposition which takes place is represented by the following equation:—



The powdered product is next washed with a small quantity of cold water in order to remove the larger quantity of potassium chloride, and then warmed with hydrochloric acid. This decomposes any chlorate which may have remained. It is then allowed to cool again, washed with a small quantity of cold water, and the residue crystallized from its solution in boiling water. Potassium perchlorate forms small rhombic crystals which possess a slightly saline taste. One part of the salt dissolves at 0° in 142·9, at 50° in 15·5, and at 100° in 5·04 parts of water (Muir). It is almost insoluble in strong alcohol and may therefore be used as a means of determining potassium quantitatively.

44 *Potassium Bromate*, KBrO_3 , is obtained, according to Stas, by passing chlorine into a warm solution of potassium bromide and caustic potash—

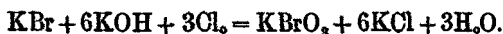

A portion of the salt crystallizes out on cooling. Alcohol is then added to the solution, when the rest of the salt is precipitated together with a small quantity of potassium chloride, and it may be easily purified by recrystallization from hot water, as it is very insoluble in the cold. According to Marignac, it forms hexagonal crystals and separates out in six-sided tables or prisms which have the appearance of cubes.

Potassium Iodate, KIO_3 . This salt can be prepared in a variety of ways. It may readily be obtained by passing chlorine into cold water containing iodine in suspension until the

whole of the substance is dissolved, then adding the calculated quantity of potassium chlorate and warming, when a rapid evolution of chlorine takes place, and on cooling pure potassium iodate crystallizes out (Henry):—

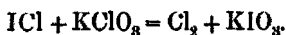

Potassium iodate crystallizes in small cubical crystals, and begins to decompose at a much higher temperature than does the chlorate. It combines with iodic acid to form the compounds $\text{KIO}_3 + \text{HIO}_3$ and $\text{KIO}_3 + 2\text{HIO}_3$.

Potassium Periodate, KIO_4 , is formed when chlorine is passed through a mixture of caustic potash and potassium iodate. It separates out as shining crystals which are isomorphous with those of potassium perchlorate. When a hot concentrated solution of the salt is mixed with alcoholic potash, rhombohedrons of potassium meso-periodate, $\text{K}_3\text{IO}_5 + 4\text{H}_2\text{O}$, are deposited. These have an alkaline reaction and absorb carbonic acid from the air. When the normal salt is evaporated together with caustic potash, triclinic prisms of potassium di-periodate, $\text{K}_4\text{I}_2\text{O}_9 + 9\text{H}_2\text{O}$, are deposited; these have an alkaline reaction.

Normal Potassium Sulphite, $\text{K}_2\text{SO}_3 + 2\text{H}_2\text{O}$, is obtained in the form of oblique rhombic octahedrons by passing a current of sulphur dioxide into a solution of potassium carbonate until all the carbon dioxide has been expelled. The solution is then allowed to evaporate over sulphuric acid. It is more soluble in cold than it is in hot water (Rammielsberg). The crystals thus obtained possess a bitter alkaline taste.

Acid Potassium Sulphite, KHSO_3 , is produced when a solution of the former salt is saturated with sulphur dioxide. On the addition of alcohol it separates out in needle-shaped crystals which taste of sulphurous acid and possess a neutral reaction.

Potassium Disulphite, $\text{K}_2\text{S}_2\text{O}_5$. This salt is formed when sulphur dioxide is passed into a hot saturated solution of potassium carbonate (Muspratt). It forms monoclinic crystals which are difficultly soluble in water and have an acid unpleasant taste.

45 *Normal Potassium Sulphate*, K_2SO_4 . The mode of preparing this salt was understood as early as the fourteenth century. It was first obtained from the residues of the manufacture of *aqua fortis*, and afterwards by the action of sulphuric acid upon crude potashes. Potassium sulphate is probably one of the salts whose constituents were first determined by analysis. Glauber, Boyle,

and Tachenius were acquainted with its composition, and in the seventeenth century it was termed *arcanum*, or *Sal duplicatum*, because, according to the then prevalent ideas, it was made up of an acid and an alkaline salt. The decomposition of this salt into its constituent parts was at that time supposed to be a most difficult matter. Indeed, Stahl proposed the following question to the French Academy: How it is possible to decompose this salt instantly when held in the hand? Although none of the Academicians were able to answer this question, Stahl accomplished his purpose by adding nitrate of silver, which at once separated vitriolic acid from the alkali.

Potassium sulphate is found native in the lavas of Vesuvius, and as kainite, $K_2SO_4, MgSO_4, MgCl_2 + 5H_2O$, in the Stassfurt beds and in those of Kalusz. It is also obtained as a by-product in several chemical manufactures, as in that of bichro-

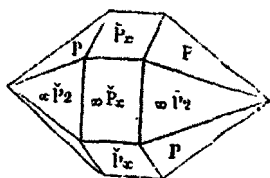

FIG. 6.

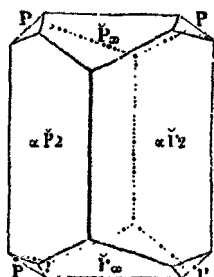

FIG. 7.

mate of potash, and in the preparation of pure potash and the purification of crude potashes as well as in the lixiviation of kelp. In order to obtain this salt from kainite, the mineral is allowed to remain for some time exposed to the air; it deliquesces, and as soon as the soluble magnesium chloride has run off the remaining salt is partially decomposed by boiling water, so that on cooling the difficultly soluble sulphate separates out.

Potassium sulphate crystallizes in small hard rhombic pyramids, Figs. 6 and 7, possessing an hexagonal or prismatic habit and having a specific gravity of 2.648. One hundred parts of water at the ordinary atmospheric temperature dissolve ten parts of this salt, whilst 26.7 parts dissolve in the same quantity of boiling solution at 102°. Aqueous alcohol dissolves it in

quantities proportional to the amount of water which the alcohol contains. The salt is quite insoluble in a solution of caustic potash of specific gravity 1.35 (Liebig), and in absolute alcohol. It has a bitter saline taste and can be volatilized only at a very high temperature.

The volatility of this and other salts has been determined by Bunsen, as follows:¹—A small bead of each salt weighing one centigram and carried on the end of a very fine platinum wire is placed in the zone of fusion of a Bunsen's flame, having a temperature of 2300°, and the time ascertained which the bead takes to volatilize. The following are the comparative results obtained for certain potassium salts, sodium chloride being taken as the standard of volatility:—

	NaCl	KCl	KBr	KI	K ₂ SO ₄	K ₂ CO ₃
Seconds	84.2	65.4	41.0	29.8	665.2	272.0
Volatility	1.000	1.288	2.055	2.828	0.127	0.310.

Potassium sulphate is used as a purgative and employed in large quantities for the manufacture of potash-alum and potassium carbonates.

Acid Potassium Sulphate, $\left. \begin{matrix} \text{H} \\ \text{K} \end{matrix} \right\} \text{SO}_4$. In 1754, Rouelle proved that in addition to the arcanum duplicatum, other salts exist containing an excess of acid chemically combined. Amongst these he mentions acid potassium sulphate, which he obtained in the crystalline state. The same salt is found native in the Grotto del Sofo, near Naples, in the form of long silky needles. It is frequently prepared in the laboratory as a by-product in the manufacture of nitric acid from saltpetre and sulphuric acid. It crystallizes in rhombic pyramids, readily dissolves in water, and possesses an acid saline taste, and when brought into contact with alcohol it is decomposed into sulphuric acid and the normal salt which is insoluble in this liquid. When the acid sulphate is recrystallized from aqueous solution the normal salt is found first to separate out, then crystals of a salt having the composition $\text{K}_2\text{SO}_4 + \text{KHSO}_4$ are deposited, and at last the acid sulphate crystallizes out.

Potassium Disulphate, $\text{K}_2\text{S}_2\text{O}_7$. This salt is obtained by heating the normal salt with sulphuric acid until the mass fuses quietly when gently ignited. It is also formed when the acid salt is heated with potassium chlorosulphonate, a compound

¹ *Phil. Mag.* [4], xxxii. 85.

obtained by the action of sulphur trioxide on potassium chloride:

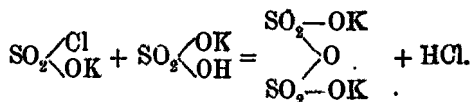

The salt crystallizes in long needles which decompose when brought into contact with water, evolving much heat and yielding the acid sulphate. When dissolved in fuming sulphuric acid this salt deposits transparent prismatic crystals of acid potassium disulphate, KHS_2O_7 .¹

46 *Potassium Nitrate*, KNO_3 (Saltpetre or Nitre). This remarkable salt was known to the ancients, being termed *Sal petrae* by Geber. It was frequently called *Sal nitri* by the later alchemists, to distinguish it from *nitrum*, by which name the ancients signified the native carbonate of soda, a salt which was not unfrequently mistaken for nitre. When trade between the East and the West increased, the mineral alkali was imported under the special name of natron, and then the word nitrum was specially reserved to designate saltpetre.

Saltpetre occurs, together with other nitrates, as an efflorescence on the soil in various hot countries, especially in Bengal, but likewise in Egypt, Syria, Persia, and Hungary, as well as in America. In Ceylon,² and other parts of India, nitre is obtained by the lixiviation of certain porous rocks, whence the origin of the word sal-petrae. These yield from 2.5 to 8 per cent. of their weight of nitre. The formation of the nitre, whether found in the soil or in porous felspathic rocks, is due to the gradual oxidation by the air of nitrogenous organic matter in contact with an alkali. In the decay and putrefaction of such bodies ammonia is first formed and nitric acid subsequently produced. Nitre is also found in the juices of certain plants. This fact was first pointed out by L. Lemery in 1717. Certain species of amaranthus, especially *A. atropurpureus*, contain no less than 22.7 of nitre in the dry plant (Boutin).

In India, a caste of men termed Sorawallahs,³ from *sora*, nitre, make it the business of their lives to collect the raw material, and to manufacture and sell the salt, which is employed locally for producing frigorific mixtures and is also largely exported

¹ Schultz Sellack, *Ber. Deutsch. Chem. Ges.* iv. 110.

² John Davy, *Quart. Journ. Science*, 1818, v. 233.

³ Palm-r, *Journ. Chem. Soc.* xxi. 318.

° The *Sorawallah* goes about the village, examining the small surface drains which issue from holes in the mud-wall, usually found around native dwellings and their cow-houses; when he detects a faint white veil-like patch of crystalline formation, on or near the dark-coloured borders of these little drains, he knows that a considerable quantity of nitre exists, on or near the surface of all the surrounding earth; he accordingly proceeds to scrape off a very thin layer of the surface soil, which he carries away to his place of manufacture, as soon as his morning's collections are finished. On arriving there, the impregnated earth so collected is thrown into an earthen vessel containing either water or water which has been poured off from previous supplies of similarly impregnated earth. When the water so used is pretty well saturated, it is poured into shallow pans of unglazed earthenware, in which it is then exposed to the combined influence of hot winds and the solar rays; these cause rapid evaporation, and the formation of crystals of nitrate of potash, which after one or two more crystallizations are ready for sale. The mother-liquor, on being further evaporated, yields a proportion of common salt, varying from one to seven or nine per cent. The *Sorawallah* makes fresh collections from precisely the same spots of ground from week to week, year to year, and from generation to generation after the manner of the eastern world; the production of nitre is constant so long as the place continues to be inhabited; it even continues to appear in large, though gradually decreasing quantities, for years after the village may have been deserted. The intervals at which fresh collections may be made from the same spot vary in different localities and in different seasons of the year, from one to seven, ten, or more days."

This production of nitre is doubtless preceded by the formation of nitrate of calcium, and this, by double decomposition with potassium carbonate, yields nitre and calcium carbonate. Indian saltpetre was introduced into Europe by the Italians, and first employed for medicinal and chemical purposes.

47 When the demand for gunpowder became great, nitre began to be manufactured in Europe. Agricola, in his celebrated treatise *De Re Metallica*, describes the process of refining saltpetre as follows:—"Saltpetre is obtained from a dry somewhat fatty earth, which is boiled with quick-lime and wood-ashes. The mass is then lixiviated and the solution evaporated."¹ Thus

¹ Berzelius, *Traité*, iii. 119.

process is employed to the present day, and during the blockade of the French ports, the artificial production of nitre was largely carried on in that country. In Sweden every landed proprietor is obliged to furnish the state with a certain quantity of nitre, and in Switzerland and other inland countries the manufacture of nitre is regularly carried on. For this purpose nitrogenous organic matter of animal or vegetable origin, after having been allowed to putrefy by exposure to air in a dark place, is mixed with substances such as lime, mortar, or wood-ashes, containing the carbonates of potash, magnesia, or lime. The mixture is then heaped together in ridges (saltpetre walls) or in low heaps (saltpetre mounds). These heaps are then moistened from time to time by the drainage of dung-heaps, or by urine, and exposed to the air. After standing for from two to three years the outer surface or saltpetre earth is removed and exhausted with water. This yields the crude saltpetre-ley which contains the nitrates of calcium and magnesium together with the chlorides of potassium and sodium. On boiling this liquor with potashes the calcium and magnesium salts are decomposed, and the clear solution is then crystallized. *Raw nitre* is thus obtained, and this by repeated solution and crystallization is converted into *purified nitre*. The same process of purification is adopted in the case of the Indian saltpetre. Even when thus recrystallized the nitre is far from being chemically pure. In order still further to purify it, the salt is dissolved in boiling water, and the solution constantly agitated when cooling. The salt then separates out in small crystals termed *saltpetre-flour*, which inclose much less of the mother-liquor, and therefore much less impurity than the large crystals. This finely-divided salt may be still further purified by washing it with a saturated solution of pure nitre which dissolves out any foreign salts which may still be present, thus rendering the saltpetre free from chlorides and fit to be employed in gunpowder-making.

Since the discovery of large quantities of potassium chloride at Stassfurt, this salt has been largely used for the artificial manufacture of saltpetre. This manufacture depends upon the fact that under certain conditions of temperature and pressure, solutions of Chili saltpetre (sodium nitrate), NaNO_3 , and of potassium chloride undergo, when mixed, a double decomposition, chloride of sodium being deposited and potassium nitrate remaining in solution. For this purpose equal molecular quantities of the two salts are dissolved in water until the specifi-

gravity of the liquor reaches 1.5. Chloride of sodium is deposited and the clear solution on cooling and on agitation deposits the saltpetre in the form of flour.

Saltpetre occurs in commerce in the form of small well-formed crystals, as well as in the form of flour. These are much purer than the larger crystals, which are often hollow and contain chloride of potassium and other impurities.

48 Potassium nitrate is dimorphous.¹ It usually crystallizes in rhombic prisms (Figs. 8, 9, 10), which not unfrequently closely resemble regular six-sided prisms. If, however, a few drops of a solution of nitre be allowed slowly to evaporate,

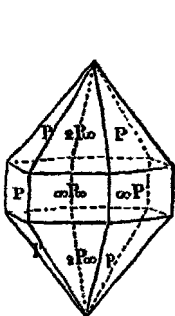

FIG. 8.

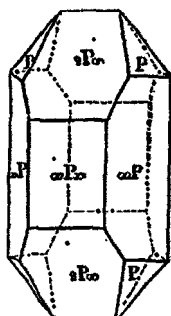

FIG. 9.

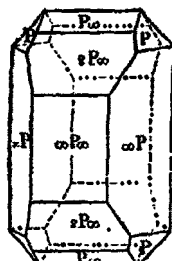

FIG. 10.

rhombohedral crystals are deposited, isomorphous with those of sodium nitrate.

Saltpetre has a specific gravity of 2.1; it melts at 339° (Person), 352° (Carnelley), and possesses a bitter cooling saline taste. It dissolves in water with absorption of much heat. This property of nitre was first pointed out by the Spanish physician Blasius Villafranca, in his tract published in 1550, entitled "Methodus refrigerandi ex vocato Sale-nitro vinum aquamque ac potus quodvis aliud genus." According to Rüdorff, 16 parts of nitre when dissolved in 100 parts of water at 13° 2 lower the temperature to + 3°.

The following table gives the solubility of saltpetre:—

One hundred parts by weight of water dissolve at—

0°	10°	20°	30°	40°	50°
13.3	21.1	31.2	44.5	64	86 parts of nitre.
60°	70°	80°	90°	100°	
111	139	172	206	247	parts of nitre.

¹ Miller, *Phil. Mag.* [3] xvii. 38.

whilst at 114° , the boiling point of the saturated solution 327·4, parts of the salt are dissolved.

Saltpetre is used in the laboratory, in medicine, for the salting or pickling of meat, to which it imparts a red colour, for pyrotechnic purposes, but chiefly in the manufacture of gunpowder.

Nitre used as an Explosive.—The Chinese are said to have been acquainted with the mode of manufacturing gunpowder from early times, although employing it rather for making fireworks than for warlike purposes. Whether the knowledge of this manufacture was brought into Europe from the East by the Saracens, or whether it resulted from an improvement in the preparation of Greek fire, is doubtful. In a Latin work by Marcus Graecus, probably written in the eighth century, mention is made of the use of saltpetre, as *sal petrosum*, as a constituent of gunpowder. None of the Arabian alchemists appear to have been aware of the property of saltpetre to deflagrate when mixed with a combustible body, and not until the thirteenth century do we find this clearly pointed out by Roger Bacon as follows:—¹ “Talis natura est (sal nitrum), quod si immediate ignitos carbones tangat, statim accensum impetu evolat.”

This fact is strikingly shown when a mixture of twenty parts of nitre and three parts of charcoal is thrown into a red-hot crucible; vivid incandescence and a violent combustion being noticed:—



An intimate mixture of fifteen parts of saltpetre and five parts of sulphur also burns very brilliantly:—



Detonating Powder, first described by Glauber, consists of a mixture of three parts of saltpetre, two parts of dry carbonate of potash, and one part of sulphur. When this mixture is heated in an iron spoon it first fuses and then explodes violently. The reaction which here occurs shows that the sulphur forms potassium sulphide, which at the high temperature of the combustion is oxidized by the nitre, free nitrogen being evolved.

Powder of Fusion, or *Baumé's Quick Flux*, also mentioned by Glauber, contains one part of nitre, one part of sulphur,

¹ Breve breviarum de Dono Dei.

and one of sawdust. This if set on fire burns with so much heat that a small silver coin exposed to it is melted in a moment.

49 *Gunpowder*.—Fire-arms appear to have been used in Florence in 1325, but field-pieces were first employed by the English at the battle of Crécy in 1346.

Gunpowder consists of a mixture, in somewhat varying proportions, of charcoal, sulphur, and nitre. Its explosive power depends on the rapid combustion of the charcoal and sulphur at the expense of the oxygen of the nitre, and the sudden liberation of a large volume of gas, which occupies several hundred times the bulk of the solid powder. Hence gunpowder can burn in a closed space or under water, as it contains the oxygen needed for the combustion in itself. It is a singular fact that it has been found in practice that the description of gunpowder which acts best is that which contains nearly two molecules of nitre to one atom of sulphur and three of carbon. Hence it was formerly believed that the decomposition which takes place when powder is fired is a very simple one, represented by the following equation:—

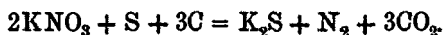

If this equation represents the decomposition which actually occurs, it follows that the most effective powder must be composed of:—

Nitre	74.9
Carbon	13.3
Sulphur	11.8
	100.0.

The compositions of the gunpowders employed by different nations approach closely to these theoretical numbers; but in no case, as will hereafter be seen, are these numbers exactly adhered to. Indeed the fact that the charcoal employed in the manufacture of gunpowder does not consist of pure carbon, but contains considerable quantities of hydrogen and oxygen, is sufficient to show that the above simple reaction cannot represent the real decomposition which occurs when powder is fired. In addition to this, however, Gay-Lussac and Chevreul proved long ago that, in addition to nitrogen and carbon dioxide, carbon monoxide is evolved in the firing of gunpowder, whilst the

residue does not merely consist of potassium sulphide, but contains the carbonate, sulphate, and other salts.

We owe the first complete experimental investigation concerning the nature of the decompositions which occur when powder is fired to Bunsen and Schischkoff.¹ They proved that a very large number of salts, such as sulphate, thio-sulphate, sulphide, and carbonate of potassium, are contained in the smoke and solid residue remaining after the powder has been fired; whilst many other gases, especially carbon monoxide, hydrogen and sulphuretted hydrogen, besides carbon dioxide and nitrogen, are formed. In these experiments the powder was fired into a vacuum, and consequently some conditions as regards temperature and pressure which are met with in the practical use of gunpowder were not maintained. Linck repeated these experiments with a different kind of powder, and Karolyi analysed the products obtained by exploding small charges in shells inclosed in a vacuous space.

The results of these experiments are seen in the following Tables:—

1. COMPOSITION OF THE POWDER.

		Bunsen and Schischkoff.	Linck.	Karolyi.	
		Sporting powder. 1.	War powder. 2.	Small-arm powder. 3.	Ordnance powder. 4.
Charcoal	Nitre . . .	78.99	74.66	77.15	73.78
	Sulphur . .	9.84	12.49	8.63	12.80
	Carbon . . .	7.69	12.31	11.78	10.88
	Hydrogen . .	0.41	9.54	0.42	0.38
	Oxygen . . .	3.07		1.79	1.82
	Ash	—		0.28	0.31
		100.00	100.00	100.05	99.97

¹ *Phil. Mag.* [4], xv. 489.

2. GASEOUS PRODUCTS OF COMBUSTION BY VOLUME.

	1.	2.	3.	4.
Nitrogen	41.12	34.68	35.33	37.58
Carbon dioxide	52.67	52.14	48.90	42.74
Carbon monoxide	3.88	4.33	5.18	10.19
Hydrogen	1.21	1.63	6.90	5.93
Sulphuretted hydrogen	0.60	7.18	0.67	0.86
Oxygen	0.52	0.04	—	—
Marsh gas	—	—	3.02	2.70
	100.00	100.00	100.00	100.00

3. TOTAL PRODUCTS OF COMBUSTION BY WEIGHT.

	1.	2.	3.	4.
Sulphate of potassium .	42.27	29.01	36.17	36.95
Carbonate „	12.64	15.43	20.78	19.40
Hyposulphite „	3.27	9.63	1.77	2.85
Sulphide „	2.13	3.75	—	0.11
Sulphocyanate „	0.30	1.16	—	—
Nitrate „	3.72	1.20	—	—
Charcoal	0.73	1.84	2.60	2.57
Sulphur	0.14	0.31	1.16	4.69
Sesquicarbonate of am- monium	2.86	2.05	2.66	2.68
Nitrogen	9.98	9.55	10.06	9.77
Carbon dioxide	20.12	22.47	21.79	17.39
Carbon monoxide	0.94	1.18	1.47	2.64
Hydrogen	0.02	0.03	0.14	0.11
Sulphuretted hydrogen	0.18	2.38	0.23	0.27
Oxygen	0.14	0.01	—	—
Marsh gas	—	—	0.49	0.40
Loss	0.56	—	0.68	0.17
	100.00	100.00	100.00	100.00
Quantity of gas (in cubic centimeters) per gram of powder	193.10	218.35	226.59	200.91

50 More recently Abel and Noble¹ have published the results of a very complete investigation on the products of combustion of powder fired under conditions similar to those which exist when it is fired in guns. The gunpowder operated upon included five kinds, viz. pebble powder, rifle large-grain (cannon powder), fine-grain powder, and rifle fine-grain powder, all English military powders, together with one spherical pellet powder of Spanish manufacture. The following table gives the complete analyses of the different powders employed:—

	Pebble powder. Waltham Abbey.	Rifle large- grain (cannon powder). Waltham Abbey.	Rifle fine-grain. Waltham Abbey.	Fine-gr.in. Waltham Abbey.	Spanish spherical pebble-powder.	
Saltpetre . . .	74.67	74.95	75.04	73.55	75.30	
Potassium sul- phate . . .	0.09	0.15	0.14	0.36	0.27	
Potassium chlo- ride . . .	—	—	—	—	0.02	
Sulphur . . .	10.07	10.27	9.93	10.02	12.42	
Charcoal {	Carbon . . .	12.12	10.86	10.67	11.36	8.65
	Hydrogen . . .	0.42	0.42	0.52	0.49	0.38
	Oxygen . . .	1.45	1.99	2.66	2.57	1.68
	Ash . . .	0.23	0.25	0.24	0.17	0.63
Water . . .	0.95	1.11	0.80	1.48	0.65	

The quantities of gunpowder exploded in the several operations varied from 100 to 750 grams. The apparatus in which the charges were exploded consisted of a mild steel vessel of great strength, carefully tempered in oil. The charge to be exploded was placed in the chamber of this steel vessel, and the main orifice of the vessel was closed by a screw plug, called the firing-plug, which fitted into its place with great accuracy. In this firing-plug itself was a conical hole, also stopped by a plug, and through this passed two insulated platinum wires, by means of which the charge could be fired by electricity. Two other apertures were made in the chamber; one of these communicated with the arrangement for allowing the gases to escape; the other contained an apparatus for determining the tension of the gases at the moment of explosion. The pressures actually observed varied from one to 36 tons on the square inch, the whole of the gaseous products remaining pent-up in the cylinder under this

¹ *Phil. Trans.* 1874. Part II., 49.

enormous pressure. The results of this investigation, may be shortly stated as follows:—

(1). The composition of the *gas* furnished by the explosion of all the English powders is remarkably uniform, but under high pressures the carbon dioxide increases and the carbon monoxide decreases.

(2). The composition of the *solid* products exhibits a much greater variation.

(3). The decomposition which an average gunpowder undergoes when fired in a closed space cannot be represented by even a comparatively complicated chemical equation.

(4). The volume of the permanent gases measured at 0° and 760 mm. furnished by the combustion of one gram of powder in a closed vessel is about 280 cbe., and is therefore about 280 times the volume of the powder.

(5). When 1 gram of powder is burnt the solid products of combustion amount to 0.57 gram, and the permanently gaseous products 0.43 gram.

(6). The tension of the products of combustion when the powder entirely fills the space in which it is fired is about 6,400 atmospheres, or 42 tons per square inch.

(7). The heat developed by the burning of 1 gram of powder is about 705 thermal units.

(8). The temperature of explosion is about 2,200° C.

The following Tables give the analytical results obtained, including the percentage composition of the products of combustion of three of the powders:—

I. (Pebble); II. R. L. G. (Rifle Large Grain); III. F. G. (Fine Grain), each under two different pressures.

	Pebble. I.		R. L. G. II.		F. G. III.	
Pressure of explosion in tons per square inch	1.4	12.5	1.6	35.6	3.7	18.2
Percentage weight of solid products	56.12	55.17	57.22	57.14	58.17	58.09
Percentage weight of gaseous products	43.88	44.83	42.78	42.86	41.83	41.92

Percentage Weights of Solid Products of Combustion.

Potassium carbonate	55.50	56.15	52.56	65.71	59.39	43.03
sulphate . . .	15.02	11.93	20.47	8.52	24.22	21.00
hyposulphite .	20.73	6.12	20.37	8.59	5.30	32.07
monosulphide .	7.41	19.12	4.02	7.23	5.12	—
sulphocyanate .	0.09	0.23	trace	0.36	0.02	0.23
nitrate . . .	0.48	0.20	0.56	0.19	0.08	0.19
oxide . . .	—	—	—	—	—	2.98
Ammonium ses- quicarbonate . }	0.16	0.08	0.06	0.18	0.15	0.03
Sulphur . . .	0.61	6.17	1.25	9.22	5.72	0.47
Carbon . . .	trace	trace	0.71	—	trace	trace

Percentage Volumes of Gaseous Products.

Carbon dioxide . .	46.66	49.82	48.99	51.79	47.41	53.02
Carbon monoxide .	14.76	13.36	8.98	8.32	12.35	7.91
Nitrogen . . .	32.75	32.19	35.60	34.61	32.35	34.20
Sulphuretted hy- drogen . . . }	3.13	1.96	4.06	2.61	3.76	2.03
Marsh gas . . .	—	0.58	0.29	0.41	—	0.50
Hydrogen . . .	2.70	2.08	2.07	2.04	4.13	2.13
Oxygen . . .	—	—	—	0.18	—	0.15

COMPOSITION BY WEIGHT (IN GRAMS) OF THE PRODUCTS OF EXPLOSION OF A GRAM OF POWDER AS FURNISHED BY THE ABOVE EXAMPLES.

	I.		II.		III.	
Potassium carbonate	0.3115	0.3098	0.3007	0.3755	0.3454	0.2499
hyposulphite	0.1163	0.0338	0.1166	0.0491	0.0308	0.1863
sulphate . . .	0.0843	0.0658	0.1171	0.0487	0.1409	0.1220
sulphide . . .	0.0416	0.1055	0.0230	0.0413	0.0298	—
sulphocyanate .	0.0005	0.0013	0.0000	0.0021	0.0001	0.0013
nitrate . . .	0.0027	0.0011	0.0032	0.0011	0.0005	0.0011
oxide . . .	—	—	—	—	—	0.0173
Ammonium ses- quicarbonate . }	0.0009	0.0004	0.0003	0.0009	0.0009	0.0002
Carbon . . .	—	—	0.0072	—	—	—
Sulphur . . .	0.0034	0.0340	0.0041	0.0527	0.0333	0.0027
Total solid . .	0.5612	0.5517	0.5722	0.5714	0.5817	0.5808

Sulphuretted hydrogen . . .	}	0.0134	0.0084	0.0166	0.0077	0.0154	0.0081
Oxygen . . .		—	—	—	—	—	0.0006
Carbon monoxide . . .		0.0519	0.0473	0.0303	0.0356	0.0416	0.0258
Carbon dioxide . . .		0.2577	0.2770	0.2597	0.2750	0.2512	0.2718
Marsh gas . . .		—	0.0012	0.0006	0.0015	—	0.0009
Hydrogen . . .		0.0007	0.0005	0.0005	0.0003	0.0010	0.0005
Nitrogen . . .		0.1151	0.1139	0.1201	0.1085	0.1091	0.1117
Total gaseous . . .		0.4388	0.4483	0.4278	0.4286	0.4183	0.4192

The total theoretic work of gunpowder, when indefinitely expended, is about 332,000 gram meters per gram, or 486 foot-tons per lb. of powder.

A difference between the products of powder of large- and small-grain can be observed. The very small-grain powders furnish decidedly smaller proportions of gaseous products than a large-grain powder, and this again smaller than a pebble powder. The most important solid products are found to consist of the following potassium salts: carbonate, sulphate, hyposulphite and sulphide. The proportion of carbonate is much higher, and that of sulphate very much lower, than had been formerly believed to be the case.

51 *Potassium Nitrite*, KNO_2 , is formed when saltpetre is heated until one atom of oxygen is evolved (*Mitscherlich*). The residue invariably contains undecomposed nitrate, and also oxides of potassium. The above decomposition takes place more readily in the presence of metallic iron, copper, or lead (*Stromeyer*). For this purpose two parts of lead may be employed to one part of saltpetre. The latter salt is fused, and the fused mass heated to dull redness, the lead then added little by little, and the cooled fused mass lixiviated with water. On evaporation, or on neutralizing in the cold with dilute sulphuric acid and adding to the solution twice its weight of alcohol, crystals of the nitrite are precipitated.

When the red nitrous fumes formed by the action of nitric acid upon starch or arsenious acid are led into a solution of caustic potash, a mixture of saltpetre and potassium nitrite is formed. These two salts can be separated by crystallization, the nitrite being the more soluble.

Pure potassium nitrite is best prepared by decomposing silver nitrite with potassium chloride (*Berzelius*), or by decomposing

amyl nitrite with the exactly necessary quantity of alcoholic potash (Chapman).

Potassium nitrite forms small indistinct crystals which deliquesce in moist air, and are insoluble in alcohol. This salt is employed for the separation of cobalt and nickel, and also in organic chemistry.

52 *Potassium Hypophosphite*, KPH_2O_3 . When phosphorus is boiled with an alcoholic solution of potash the above salt is formed. It is deposited in deliquescent hexagonal tables which when heated in the air take fire and burn with a yellow flame.

Potassium Phosphite. If phosphorous acid be saturated with potash, and the solution evaporated in a vacuum, a syrupy liquid is left, which when dried at 280° possesses the composition K_2HPO_3 .

Normal Potassium Ortho-Phosphate, K_3PO_4 , is formed, according to Graham, when phosphoric acid is ignited with an excess of potassium carbonate. It is readily soluble in water, and crystallizes in small needles. The mono-acid salt HK_2PO_4 does not crystallize (Graham), and the diacid salt H_2KPO_4 is obtained by adding phosphoric acid to a solution of carbonate of potash until the liquid turns blue litmus red, and this on drying is again turned blue. The salt deposits in rhombic crystals easily soluble in water but insoluble in alcohol.

Potassium Pyrophosphate, $K_4P_2O_7$. When the mono-acid ortho-phosphate is ignited this salt is formed. It deliquesces on exposure, and deposits in the form of fibrous crystals containing 3 molecules of water, when the solution is evaporated. The acid salt, $H_2K_2P_2O_7$, separates out as a white deliquescent mass when the normal pyrosalt is dissolved in acetic acid and alcohol added to the solution.

Potassium Monometaphosphate, KPO_3 . This salt is obtained by the ignition of the diacid orthophosphate. It is almost insoluble in water. Dimetaphosphate, $K_2P_2O_6 + H_2O$, is a crystalline, soluble salt; it is prepared by decomposing the corresponding copper salt with potassium sulphide. On ignition it yields monometaphosphate.

53 *Normal Potassium Arsenate*, K_3AsO_4 , is prepared by adding an excess of caustic potash to arsenic acid. On evaporation it is deposited in the crystalline form (Graham). Mono-acid potassium arsenate, K_2HASO_4 , crystallizes with difficulty, but the diacid salt, KH_2AsO_4 , can be obtained in large crystals. This last salt was known as Macquer's arsenikalisches mittelsalz, and was

formerly prepared by deflagrating equal parts of arsenious acid and nitre, dissolving in water, and leaving the solution to crystallize. These crystals are isomorphous with diacid potassium phosphate, and like these turn blue litmus-paper red, but this red colour disappears on drying.

Potassium Arsenite. Arsenic trioxide dissolves easily in an aqueous solution of potash, and if the minimum quantity of potash be employed, the compound $\text{KAsO}_2 + \text{H}_3\text{AsO}_3$ may be obtained as a crystalline powder when the solution is mixed with alcohol. If this is warmed with a solution of potassium carbonate, potassium meta-arsenite, KAsO_2 , is formed, and this when warmed with caustic potash yields potassium diarsenite, $\text{K}_2\text{As}_2\text{O}_5$, likewise precipitable by alcohol.

A solution of potassium arsenite is used in medicine under the name of Fowler's Solution. This solution is prepared by boiling one part of solid arsenic trioxide with an equal weight of carbonate of potash in distilled water, and diluting the clear liquid so as to form 90 parts of solution.

54 *Potassium Metaborate*, KBO_2 . When boric acid and carbonate of potash (or any other potash salt containing a volatile acid) are fused together in the proper proportions the above salt is obtained. It is difficultly soluble in water, and deposits in small monoclinic crystals, possesses an alkaline reaction, and absorbs carbonic acid from the air with formation of potassium pyroborate or tetraborate. This latter substance is obtained by adding caustic potash to a solution of boric acid until the liquid attains an alkaline reaction. It is easily soluble, crystallizes in hexagonal prisms having the formula $\text{K}_2\text{B}_4\text{O}_7 + 5\text{H}_2\text{O}$, and possesses a faint alkaline taste. If hot solutions of boric acid and carbonate of potash be mixed together, in the proportion of one molecule of the former to two molecules of the latter, glittering rhombic crystals of *potassium triborate*, $2\text{KB}_3\text{O}_5 + 5\text{H}_2\text{O}$, separate out, and when a hot solution of caustic potash is saturated with boric acid, rhombic pyramids of *potassium pentaborate*, $\text{KB}_5\text{O}_8 + 4\text{H}_2\text{O}$, are deposited.

55 *Potassium Metasilicate*, K_2SiO_3 , is formed when silica is fused together with the requisite quantity of carbonate of potash. Indeed, this salt is formed even when an excess of carbonate is employed, for H. Rose has shown that one molecule of silica cannot liberate one molecule of carbon dioxide from an alkaline carbonate.¹ Hence we may conclude that the ortho-silicate, K_4SiO_4 , does not exist.

¹ Gilbert's *Ann.* lxxiii. 84.

Potassium metasilicate forms a glassy mass which deliquesces on exposure to moist air. It also absorbs carbonic acid from the air, and is gradually transformed into a transparent jelly which in time shrinks together, and after some weeks becomes hard enough to scratch glass. It is probable that opal and flint are formed in a similar manner (Kuhlmann). Van Helmont was aware that the substance obtained by fusing silica with an excess of alkali became liquid on exposure to air, and Glauber termed this *liquor silicum*.

Potassium Tetrasilicate, $K_2Si_4O_9$. This salt, known as the soluble glass of Fuchs, was discovered in 1818. Unlike the preceding compound, it is not deliquescent, but soluble in water, whence its name is derived. It is prepared by fusing 45 parts of quartz, 30 of potashes, and 3 of powdered charcoal, for from five to six hours. The charcoal serves to assist the evolution of the carbon dioxide, which is thereby reduced to carbon monoxide.

In order to prepare pure potassium tetrasilicate the hard greyish-black glass thus obtained is next boiled with five times its weight of water, the clear solution boiled down, and one-fourth its bulk of strong alcohol added. The precipitate which forms gradually shrinks together, the mother-liquor is then poured off, and the residue washed with a little cold water. It dissolves completely in water. Potash water-glass is used for a variety of purposes, but it is now usually supplanted by soda-water glass, a compound also discovered by Fuchs, a description of which will be found in the sequel.

Potassium Fluosilicate, K_2SiF_6 , is obtained when hydrofluosilicic acid is brought into contact with a solution of a potassium salt. When the acid is added in small quantities no precipitate is observed to form, but soon the liquid begins to exhibit iridescent colours, and after a while the insoluble potassium fluosilicate separates out as a semi-transparent mass. After washing with water and drying, the salt is obtained as a fine white powder difficultly soluble in cold, though easily soluble in hot water. By slow cooling it may be obtained in the form of bright octohedrons, which sometimes show cubic faces (Marignac).

56 Normal Potassium Carbonate, K_2CO_3 . This salt, well-known under the name of potashes, was originally obtained solely from the ashes of wood and other land plants, as the name implies, boiled in pots. Even to the present day this

compound is largely obtained according to the old process, especially in Canada, North America, Moravia, the Steppes of Southern Russia, Hungary, and other districts where wood is plentiful. The ashes are first lixiviated in wooden tubs fitted with false bottoms, and the lye, which is of a dark brown colour, is evaporated in iron pots either to dryness or to the point at which crystallization commences, and in this way a brown mass of crude potashes is obtained. This residue is generally calcined in a reverberatory furnace, in order to drive off the adhering water and to burn away the brown organic matter adhering to it. The crude or calcined potashes obtained in this process are usually slightly coloured either red, yellow, or green by iron- or manganese compounds. To the pure white potashes the name pearl-ash is given. Crude potashes contain besides potassium carbonate, potassium chloride, potassium sulphate, potassium silicate, and sodium compounds. In the preparation of the American ash, caustic lime is added, and hence this product contains large quantities of caustic potash. When the crude potashes contain much caustic alkali it is usual to get rid of this by heating the ash in a reverberatory furnace with sawdust. In order to purify the crude potashes they are dissolved in two parts of boiling water, the solution filtered, evaporated down, and allowed to stand for some days, when the greater part of the sulphate separates out. The liquor, poured off from this deposit, is boiled down until the salt begins to separate out and then allowed to cool, when the potassium carbonate is deposited in crystals. The saline mass is thrown into a drainer, and washed with a little cold water to remove the mother-liquor, containing chloride and silicate, retained by the crystals. The residue is then heated to redness and forms refined potashes or pearl-ash. This again, in America especially, is refined by dissolving again and allowing the less soluble impurities to separate out. The pearl-ash thus produced is of first-rate quality.

During the last twenty years, owing to the high price of potashes and the gradual extinction of forests, and in consequence of this alkali being a substance largely needed in manufacturing processes, other sources of potassium compounds have been sought. The suggestion has frequently been made that felspar and other silicates of potash should be employed for the purpose, and this proposition seems a very plausible one, inasmuch as it is by the slow decomposition of these

silicates that all fruitful soils obtain their potash salts. At the same time, experience has shown it to be impossible to obtain potash from this source, and fortunately other richer sources of potassium compounds have been discovered. Amongst these the first to be noted is that from the manufacture of beet-root and cane-sugar. Beet-root is a potash plant, its ash being particularly rich in potassium compounds. The first attempt to obtain potash from this plant was that of incinerating the leaves. This process however did not prove available, and it was afterwards suggested that the molasses or uncrystallizable sugar, which also contains large quantities of potash salts, should be first allowed to ferment, whereby the sugar is converted into alcohol, and the liquors evaporated. In this way a black mass is obtained, consisting of alkaline salts together with carbon. On lixiviation a solution is obtained, and this is evaporated until it attains a specific gravity of 1.25-1.30. Potassium sulphate separates out together with sodium carbonate. The hot lye is then drawn off, and, on cooling, potassium chloride is obtained, together with some potassium sulphate. Further evaporation and cooling yields a mass which chiefly contains the carbonates of potash and of soda, together with a little potassium chloride and sulphate. These raw beet-root potashes are termed "salin" on the continent. This crude material is again lixiviated and the liquors are boiled down again, and a repetition of this process is carried on until the material contains 82-84 per cent. of potassium carbonate. The potashes obtained by this process vary very much in quality, according to the district where the beet-root has been grown. They are richer where the beet-root has been recently introduced than where the soil has been partially exhausted.

Another remarkable source of potassium is that from sheep-wool. It has already been mentioned that sheep withdraw a considerable quantity of potash salts from the soil. Chevreul first pointed out that the sweat or suint of sheep contains no less than one-third of its weight of potash salts. The brown liquors in which the wool has been washed are evaporated to dryness, and the solid residue calcined in retorts, by which means ammonia and a gas used for illuminating purposes are evolved; the residual mixture of charcoal and alkaline salts is again lixiviated and treated in a similar way to the salin already described.

Potashes are lastly obtained in still larger quantity from potassium sulphate, which, as we have seen, separates out in the manufacture of potashes, and is likewise obtained in considerable quantity both from the Stassfurt beds and from sea-water. A large quantity is also obtained by heating potassium chloride with sulphuric acid, and in the manufacture of bichrome. For the purpose of converting the sulphate into the carbonate it is heated in a reverberatory (black-ash) furnace with the requisite quantity of limestone and coal, the product being worked exactly according to Leblanc's process for obtaining carbonate of soda from salt-cake. The details of this process will be found under the Sodium Compounds. The present extent of the potash industry is seen from the following numbers taken from the report of the Vienna Exhibition of 1869.¹

Yearly Product of Potashes in kilos.

From wood ashes	20,000,000
„ beet-root	12,000,000
„ suint of sheep	1,000,000
„ sulphate of potassium .	15,000,000

These numbers clearly show that the potash industry is undergoing a most remarkable change. Twenty years ago the whole of the potash salts were obtained from wood-ashes, and the export of Russian potashes amounted in 1864 to more than 11,000,000 kilos, whilst in 1873 it amounted to only 5,500,000 kilos. The export of American potashes has likewise diminished in the last ten years from 1,900,000 kilos to 388,000 kilos.

In order to prepare chemically pure potassium carbonate, it was customary formerly to employ pure cream of tartar (hydrogen potassium tartrate) which was heated in covered iron crucibles. A mixture of carbon and potassium carbonate was thus obtained, and by lixiviating the residue with water and evaporating the solution down in a silver basin the pure salt was deposited. This salt even now retains the name of salt of tartar. Instead of the expensive tartar it is now customary to employ the much cheaper hydrogen potassium carbonate or bicarbonate of potash, which can be easily prepared in the pure state, and which on heating yields water, carbon dioxide, and potassium carbonate:

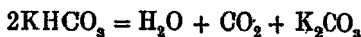

¹ *Ber. Entw. Chem. Industrie*, 409.

When prepared on the manufacturing scale, the carbonic acid which is evolved is made use of for the preparation of a fresh portion of bicarbonate.

Pure potassium carbonate occurs either in the form of a white granular powder, or as a white solid mass which possesses a strong alkaline reaction and has an alkaline and slightly caustic taste. It melts at 838° (Carnelley), and then loses a small quantity of carbon dioxide. At a white heat it is volatilized. It is extremely hygroscopic and very soluble in water, and when exposed to the air it soon deliquesces to an oily liquid which has received the name of "oleum tartari per deliquium." According to Mulder, 100 parts of water dissolve the following quantity of salt at—

0°	20°	40°	60°	80°
89.4	112	117	127	140 parts.

At 135° , the boiling point of the saturated solution, 100 parts of water dissolves 205 parts of the salt. For the specific gravity of solutions of this salt, Gerlach's tables may be consulted.¹ When the concentrated solution is allowed to stand monoclinic crystals possessing a glassy appearance and having the composition $2K_2CO_3 + 3H_2O$ are deposited. These on heating to 100° fall to a white powder having the composition $K_2CO_3 + H_2O$, and this at 130° loses all its water.

Carbonate of potash is largely used in the manufacture of soft-soap, yellow prussiate, and chromate of potash, and crystal glass.

Hydrogen Potassium Carbonate, $KHCO_3$. This salt, also known as bicarbonate of potash, is obtained by passing carbon dioxide through a concentrated solution of the normal salt when the bicarbonate, which is much less soluble, crystallizes out. Another process is to pass a current of carbon dioxide over the slightly moistened purified potashes, the product being recrystallized from warm water. It forms large transparent crystals belonging to the monoclinic system, which possess a saline taste and a slightly alkaline reaction. 100 parts of water dissolve at the ordinary temperature, about 25 parts, and at 70° 45 parts, of the salt. When the solution is boiled carbon dioxide is given off, and when the dry salt is heated to 190° it is thoroughly decomposed into the normal carbonate and carbon dioxide.

¹ *Zeitsch. Analyt. Chem.* viii. 279.

Potassium Cyanide, KCN. Commercial potassium cyanide is prepared according to Liebig's method as follows. Eight parts of dry ferrocyanide of potassium are melted in an iron crucible together with three parts of potassium carbonate:



As soon as no further evolution of gas takes place and the liquid appears clear, the crucible is taken from the fire and the melted mass poured off from the finely divided iron which remains behind. As is seen in the above equation, the cyanide thus prepared contains a small quantity of cyanate. For ordinary purposes this admixture is of no consequence. A purer product can be obtained by heating the dry ferrocyanide to a bright red heat:



A portion of the melted mass can be poured off and thus obtained in the pure state. That which remains in contact with the carbide of iron must be dissolved out with water, or, better still, with boiling alcohol. Chemically pure potassium cyanide is best prepared by passing the vapour of hydrocyanic acid into an alcoholic solution of potash. The salt then separates out as a white crystalline powder.

Potassium cyanide has a sharp bitter taste; it is exceedingly soluble in water and dissolves slightly in cold, and somewhat more readily in hot, alcohol. When the concentrated aqueous solution of the salt is allowed to evaporate over strong sulphuric acid it deposits crystals in the form of regular octohedrons. Potassium cyanide is readily fusible, and on cooling solidifies in cubes. The weakest acids, even carbonic acid, decompose the salt with evolution of hydrocyanic acid. Hence the salt smells of this acid when exposed to the air, and is itself as poisonous as the acid.

Potassium cyanide is used in large quantity in photography, and in the laboratory, where it is used largely as a reducing agent. This is due to the fact that when in the fused state it withdraws oxygen from many oxides and is converted into potassium cyanate. When heated with nitric acid or chlorate of potash violent explosions occur. Potassium cyanide and sulphur when melted together combine directly, forming *potassium thiocyanate*. This compound is also formed when the cyanide is heated with several metallic sulphides.

Potassium Cyanate, KOCN. This salt is prepared by igniting an intimate mixture of two parts of dried yellow prussiate of potash and manganese dioxide on a flat iron dish until the mass has attained a brownish-black colour. It is well stirred, and the temperature increased until the mass begins to soften, after which it is allowed to cool. The solid residue is then exhausted with alcohol of 80 per cent., and the alcoholic solution evaporated until crystallization begins.

Potassium cyanate crystallizes in transparent tables, which are readily soluble in water and in alcohol. The aqueous solution gradually decomposes into ammonia and acid potassium carbonate:

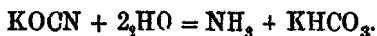

Potassium cyanate is employed for the preparation of some organic compounds.

Potassium Thiocyanate, KSCN, is prepared by gently heating a mixture of forty-six parts of dried yellow prussiate of potash, seventeen parts of carbonate of potash, and thirty-two parts of sulphur. The mass when cold is boiled with alcohol. On cooling the filtered liquid the above salt separates out in long striated transparent prisms, which melt readily when heated, and deliquesce in moist air. It is very soluble in water; if 500 grams of this salt be mixed with 400 grams of cold water the temperature of the mass sinks to -20° (Rüdorff); hence this salt is largely used as a refrigerant.

The formation of potassium thiocyanate serves as a delicate test for the presence of sulphur or sulphides. For this purpose the body under examination is fused with a small quantity of potassium cyanide, the fused mass heated with water, and a drop of ferric salt added to the slightly acidified solution. If sulphur or sulphides were present, the deep blood-red colouration of ferric thiocyanate is noticed.

POTASSIUM AND SULPHUR.

57 *Potassium Monosulphide*, K_2S . This substance is formed, according to Berzelius, by leading hydrogen over potassium sulphate. It forms a pale red crystalline mass, which on heating becomes darker and melts to a black liquid below a red-

heat. Berthier obtained the same compound as a flesh-coloured mass by strongly heating the sulphate with carbon:

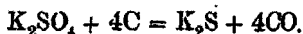

In order, however, to obtain this substance a larger amount of carbon is needed than that represented in the above equation, otherwise a mixture of higher sulphides with potassium carbonate is obtained (Wittstock). Indeed it appears impossible to obtain perfectly pure monosulphide, as even the substance obtained by reduction with hydrogen contains higher sulphur compounds.¹ The mass deliquesces in moist air, and dissolves in water with evolution of considerable heat.

If potash lye be saturated with sulphuretted hydrogen, and if then the same quantity of alkali be again added to the solution, a solution of the monosulphide is obtained. This remains colourless if the air be excluded, possesses an alkaline taste, and acts on the skin as a strong caustic. When evaporated in a vacuum at a low temperature, four-sided prisms are deposited, having the formula $\text{K}_2\text{S} + 5\text{H}_2\text{O}$.² If this aqueous solution be boiled, sulphuretted hydrogen is given off, and when exposed to the air it becomes yellow from absorption of oxygen and carbon dioxide, and formation of potassium thiosulphate and potassium carbonate, the sulphuretted hydrogen which is liberated decomposing with formation of water and sulphur, and the latter substance uniting with the monosulphide to form higher sulphides. On shaking the yellow solution with metallic copper it again becomes colourless.

Potassium Hydrosulphide, KSH. This substance was first prepared by Gay-Lussac by heating potassium in dry sulphuretted hydrogen. He then observed that the same quantity of potassium which was capable of evolving one volume of hydrogen from water was able to combine with all the sulphur in two volumes of sulphuretted hydrogen, liberating half the hydrogen:

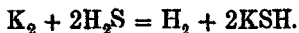

Berzelius obtained the same compound by the action of sulphuretted hydrogen on carbonate of potassium heated to dull redness:



This body forms a white or yellowish mass, which when heated

¹ Bauer, *Journ. prakt. Chem.* lxxv. 246.

² Schöne, *Pogg. Ann.* cxxxl. 380.

to dull redness melts to a liquid, which at a higher temperature becomes of a dark red colour. It is very soluble in water, and the aqueous solution is very easily obtained by saturating caustic potash solution with sulphuretted hydrogen. This forms a colourless liquid which smells slightly of sulphuretted hydrogen, has an alkaline and bitter taste, and on exposure to the air becomes yellow, owing to the formation of higher sulphides. When exposed a still longer time to the action of the air it becomes colourless, inasmuch as potassium thio-sulphate is formed. If the concentrated solution be allowed to evaporate over caustic lime or caustic soda in a vacuum, colourless glittering rhombohedral crystals separate out, having the formula $2KSH + H_2O$.

58 *Potassium Trisulphide*, K_2S_3 . If the vapour of carbon disulphide be led over a slightly ignited potassium carbonate a mixture of the above compound with carbon is obtained. In this case potassium thiocarbonate is first formed as a red liquid, which then decomposes into the above mixture (Schöne):

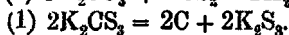
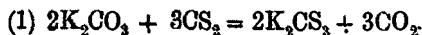

The pure compound is also obtained by heating the tetrasulphide to a temperature of above 800° . It forms a light-brown crystalline mass soluble in water.

Potassium Tetrasulphide, K_2S_4 , is formed when one part of potassium carbonate is melted with two parts of sulphur, and sulphuretted hydrogen led through the fused mass as long as water and sulphur are given off. It forms a reddish-brown crystalline mass readily soluble in water, forming with it a crystallizable compound which may also be obtained when potassium monosulphide is boiled with the requisite quantity of flowers of sulphur, and the solution allowed to evaporate in a vacuum. Thin orange-red coloured tables are thus obtained having the composition $K_2S_4 + 2H_2O$ (Schöne).

Potassium Pentasulphide, K_2S_5 , is prepared by heating any of the lower sulphides with sulphur at temperatures below 600° . It forms a red semi-transparent mass which melts upon heating, and possesses a bitter and alkaline taste. When fused in a current of steam potassium sulphate is formed (Drechsel):

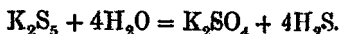

It is easily soluble in water, and its solution is likewise formed

when an aqueous solution of any of the lower sulphides is saturated with sulphur.

The sulphides of potassium are all decomposed by acids, sulphuretted hydrogen being evolved, and sulphur-milk separating out in the case of the four latter compounds.

Liver of Sulphur or *Hepar Sulphuris*. This is an old name given to a mixture of potassium polysulphides with potassium sulphate, or potassium thiosulphate. It is obtained by gently heating sulphur with carbonate of potassium in a covered vessel. The composition of the liver-coloured mass thus obtained is variable, according to the proportions in which the bodies have been mixed and the temperature to which they have been heated. Liver of sulphur was well known to the alchemists of the middle ages. Stahl considered it to be a compound of the alkali with sulphur, and called it "sulphurized alkali." He also knew that it could be prepared by heating sulphate of potash with carbon, and used this fact to prove that only one kind of phlogiston exists (see Vol. i. p. 13). Liver of sulphur is used in medicine, and is termed in the Pharmacopœia, *potassa sulphurata*.

POTASSIUM AND NITROGEN.

59 *Potassamide*, NH_2K . This compound was discovered by Gay-Lussac and Thénard in 1811. It is formed when potassium is gently heated in ammonia gas; the metal melts, first becomes of a bright blue colour, then green, and afterwards of a yellowish-brown tint. It shrinks considerably on cooling, and thus becomes separated from the glass in which it is contained. It burns with the evolution of bright sparks when heated in oxygen, and is decomposed in contact with water, often with the liberation of light and heat:

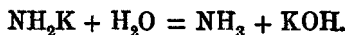

Potassium Triamide, NK_3 , forms a greenish-black infusible mass obtained by igniting the foregoing compound in the absence of air:



At a very high temperature it decomposes into its constituent elements, and takes fire in the air easily, burning with a dark

reddish flame. It is violently decomposed when brought into contact with water.

DETECTION AND ESTIMATION OF POTASSIUM AND ITS COMPOUNDS.

60 The best indication of the presence of potassium compounds is the violet colour which they impart to the non-luminous flame. This tint is, however, not seen if even a small quantity of a sodium compound be present. In this case the flame may be observed through a blue cobalt glass, which absorbs the yellow rays. It is however preferable to examine the flame by means of the spectroscope. The spectrum of potassium compounds thus obtained contains only two characteristic lines:—viz., $K \alpha$ in the outermost red, approaching the ultra red rays and coincident with the dark line A of the solar spectrum; and a second line $K \beta$, situated far in the violet rays, towards the other end of the spectrum, also identical with a dark solar line. A very indistinct line exists coincident with Fraunhofer's B, seen only when the light is very intense, and this is not so characteristic. Owing to the position of the two lines, $K \alpha$ and $K \beta$, both situated near the limit at which our eyes cease to be sensitive to the rays, this reaction for potassium is not very sensitive, but $\frac{1}{1000}$ of a milligram can be readily detected. The absorption spectrum of potassium has been mapped by Roscoe and Schuster.¹ It is totally different from the emission spectrum just described, being a channelled space spectrum. Observed at a low temperature the green-coloured vapour exhibits a well-marked series of bands, one group in the red (α) and two groups (β and γ) at each side of the sodium line being seen. These bands are all shaded off towards the red, and in general appearance resemble those of the iodine spectrum.

In order to separate soluble potassium compounds from other metallic salts, they must be precipitated either as the perchlorate, the acid tartrate, or the platinum double chloride K_2PtCl_6 .

This last compound is employed for the quantitative determination of potassium, and for the separation of this metal from sodium. To the mixed chlorides an excess of platinum tetrachloride is added, the liquid is then evaporated on the water-bath, and the cooled residue mixed with strong alcohol, in

¹ *Proc. Roy. Soc.* xxii. 367.

which the excess of platonic chloride and the sodium double-salt easily dissolve. The potassium double-salt is then collected, dried and weighed.

The mixed chlorides of potassium and sodium can also be weighed, and then converted into sulphates by treatment with strong sulphuric acid, and the weight of these determined. From these data the amount of potassium (x) and of sodium (y) present can readily be calculated when the molecular weights of the several salts are known. Thus:—

K = 39·04	Na = 22·99	K ₂ = 78·08	Na ₂ = 45·98
Cl = 35·37	Cl = 35·37	SO ₄ = 95·82	SO ₄ = 95·82
74·71	58·36	173·90	141·80

If A represent the weight of the mixed chlorides and B that of the mixed sulphates, we have:—

$$A = \frac{74\cdot41}{39\cdot04}x + \frac{58\cdot36}{22\cdot99}y.$$

$$B = \frac{173\cdot9}{78\cdot08}x + \frac{141\cdot8}{45\cdot98}y.$$

From which the values of x and y can readily be obtained.

The atomic weight of potassium has been most accurately determined by Stas. As a mean of 8 experiments he found that 100 parts of potassium chlorate yielded 60·846 parts of potassium chloride on ignition. Moreover, 69·103 parts of potassium chloride were needed, as a mean of 19 experiments, to precipitate 100 parts of silver from solution; and 100 parts of silver nitrate, as a mean of 10 experiments, required 43·876 parts of chlorine as potassium chloride for complete precipitation. These experiments give the number 39·04 as the mean for the atomic weight of potassium when chlorine = 35·37 and oxygen = 15·96.

SODIUM. Na = 22·29.

61 In the writings of the Old Testament (Jeremiah. ii. 22) we find a substance used for washing purposes mentioned as *nether*. This same substance is mentioned in Proverbs as being one which effervesces when vinegar is poured over it, and in our version this substance is called nitre. In Luther's translation

the name chalk is given to this body, but there can be little doubt that by the word nether was meant trona, or the native carbonate of soda, to which the names *νίτρον* in Greek and *nitrum* in Latin were applied.

At a later date the name nitrum was given to saltpetre; but up to the fourth century there is no doubt that nitrum signified the carbonate of soda originally obtained from the salt lakes in Egypt, to which the names *flos salis* and *spuma nitri* were given. Reasons for believing this are, amongst others, the facts stated by Pliny, that in the first place this nitrum does not decrepitate when thrown on the fire ("*igni non exsilit nitrum*") as saltpetre does; that, secondly, it possesses a fatty touch, this property being heightened by boiling it with lime; thirdly, that the nitrum is used both with and without oil in the baths (in *balineis utuntur (nitro) sine oleo*); and fourthly, that it is largely used in the manufacture of glass.

The word nitrum was, as we have already remarked, long indiscriminately applied to both soda and potash. The history of the distinction between these two bodies has also been dwelt upon. The terms soda and natron came into general use in the fifteenth century to distinguish fixed alkali from nitre.

Metallic sodium was first obtained by Davy¹ in 1807, by exactly the same process as that by which he prepared potassium (see p. 55).

The sodium compounds occur very abundantly and are universally diffused. Large quantities of sodium chloride, NaCl , are found in extended deposits as rocksalt in different parts of the world and in various geological formations, whilst the same compound occurs in solution in sea-water, salt lakes, salt springs, and many mineral waters. Sodium nitrate, or, Chili saltpetre, NaNO_3 , is deposited in beds several feet thick in the rainless districts of Southern Peru and Bolivia; the carbonate, Na_2CO_3 , and the sulphate, Na_2SO_4 , are found either in springs or as deposits in the beds of dried-up lakes. Many minerals, especially nepheline, sodalite, albite, labradorite, contain sodium silicate in considerable quantity, whilst traces of sodium compounds occur in all silicates. Indeed it is difficult to find any substance which does not contain traces of sodium, as evidenced by the very delicate spectroscopic reaction.

Sodium compound sare also found in the bodies of vegetables and animals. Plants growing in or near the sea contain sulphate,

¹ *Phil. Trans.* 1808, pp. 5, 21.

iodide, and chloride of sodium. The whole of the animal body, especially the juices, is rich in sodium compounds, the carbonate, chloride, and phosphate chiefly occurring, together with sodium salts of organic acids.

Sodium salts are, however, not characteristic of vegetable life in the same sense that potassium salts are. Thus, whilst the latter alkali is always present in larger quantities in certain organs of the plant than in others, sodium appears to be generally equally diffused throughout the whole organism. It is also a remarkable fact that the sodium salts contained in the ashes of plants are insoluble in water, as they combine with the phosphates of the alkaline earths to form insoluble compounds. For this reason the presence of sodium compounds in the ashes of plants has often been overlooked.

Duhamel and Cadet showed that if the plant *Salsola Solu*, which grows near the sea, and which yields an ash rich in soda salts, be transplanted to an inland situation, the ash gradually loses soda and gains in potash, until at last the whole of the former disappears. On the other hand, if inland plants are grown near the sea the reverse change takes place (Correnwinder).

62 Preparation of Metallic Sodium. Metallic sodium can be obtained by electrolysis, like potassium, but less easily, according to Davy, than the last-named metal.

Soon after Davy's discovery Gay-Lussac and Thénard showed that sodium can be obtained by decomposing caustic soda with metallic iron at a white heat, and Brunner obtained it by igniting a mixture of carbonate of soda and charcoal.

This latter is the process now adopted for the manufacture of sodium. This is at present extensively carried on, the metal being used for the preparation of magnesium and for a variety of other purposes. This manufacture is simpler and easier than that of potassium, as there is no liability to explosions.¹ Common soda-ash is employed as the source of sodium; 30 kilograms of this is well ground up with 13 kilograms of slack or small coal and 3 kilograms of chalk. This mixture is placed in an iron cylinder 1·2 meters long and 0·14 meter in diameter, coated with fire-clay, and this introduced into a reverberatory furnace in which it can be heated up to whiteness. The ends of the cylinder are closed by iron plates, one of which is perforated with an inch iron gas-pipe. Through this pipe the

¹ Deville, *Ann. Chim. Phys.* [3], xliii. 5.

gas and sodium vapour pass, the latter being condensed by an iron receiver similar to that employed in the manufacture of potassium. The escaping carbon monoxide burns with a yellow flame, whilst the molten sodium drops out from the lower end of the receiver, falling into a dry iron pot placed beneath. The furnace is so constructed that several cylinders can be heated at once, and as soon as one is exhausted it is withdrawn and replaced by a freshly charged one. A considerable quantity of the sodium is volatilized and burns; some adheres to the receiver, and the reduction does not occur completely, so that in a well-

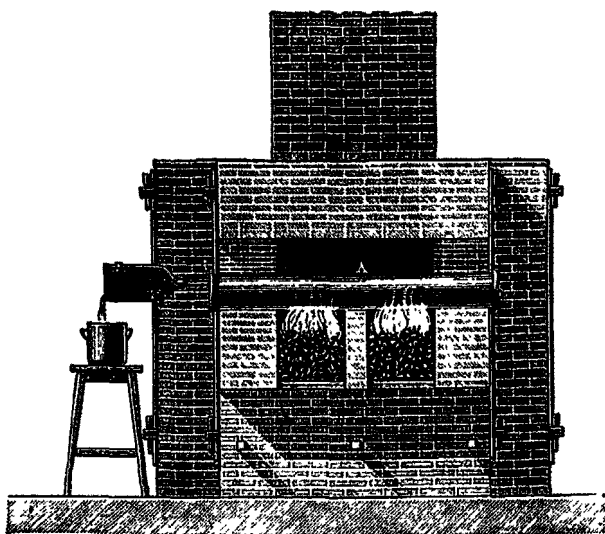

FIG. 11.

conducted operation the sodium obtained is about one-third of the weight of the theoretical yield.

The sodium thus obtained is sufficiently pure for ordinary purposes, and only requires to be remelted and then cast into sticks about one inch thick and a foot long. These may be preserved in closed vessels in dry air without undergoing any appreciable oxidation for a long time. The sticks of metal thus preserved become covered by a thin coating of oxide, which prevents further oxidation. When in smaller masses it is advisable to keep the sodium under petrolcum.

63 Properties. Sodium is a white metal possessing a high silver-white lustre. It may be obtained in the crystalline condition by sealing up 100 grams of metal in a glass tube filled with hydrogen. The sodium is melted at one end of the glass tube and then allowed to filter through some wire-gauze placed in a narrowed portion of the tube. The melted metal is thus rendered perfectly free from oxide, and must be fused in the clean part of the tube, allowed to cool partially, and then the central liquid portion suddenly poured off from the solidified crust. According to Long¹ sodium crystallizes in the quadratic system, forming acute octohedrons. The specific gravity of sodium at 0° was found by Davy to be 0.9348; more accurate and more recent determinations of Baumhauer give 0.9735 as its specific gravity at 13°.5. At -20° sodium is rather hard, at 0° it is very ductile, at the ordinary temperature it has the consistency of wax, at 50° it is semi-fluid, and it melts at 95°.6 (Bunsen), forming a liquid resembling mercury in its appearance. Sodium volatilizes at a red-heat, but rather less easily than potassium. Its vapour is colourless when seen in thin layers, but of a peculiar purple colour by transmitted light when seen in quantity (Roscoe and Schuster). It conducts heat and electricity better than any of the metals with the exception of silver, copper, and gold (Matthiessen), and next to caesium, rubidium, and potassium, it is the most electro-positive metal (Bunsen).

When freely exposed to moist air sodium oxidizes like potassium, although not quite so rapidly. It burns with a bright yellow flame when heated in the air, forming the monoxide and the dioxide. Thrown on to cold water it swims on the surface, disengaging hydrogen and dissolving, but not evolving heat enough to ignite the hydrogen. Brought into contact with hot water, or thrown on to a thick paste of starch, the evolved hydrogen ignites and burns with a yellow sodium-tinted flame.

Sodium is used for the preparation of silicon, boron, magnesium, and aluminium. Sodium-amalgam is employed in the process of extracting gold from the quartzose rock in which it occurs, and this amalgam, like sodium itself, is of great service as a reducing agent in the laboratory.

Sodium forms with potassium an alloy which is liquid at the ordinary temperature, and looks like mercury. When it contains

¹ *Chem. Soc. Journ.* xiii. 123.

16 parts of potassium to 10 parts of sodium this amalgam becomes pasty at 8°, and solidifies at lower temperatures. If more potassium is contained in it the amalgam remains liquid below 0°. The amalgam is not only obtained by melting the two metals together under rock oil, but also by adding sodium to fused acetate of potassium when gases are rapidly evolved and the amalgam is formed (Wanklyn).

SODIUM AND HYDROGEN.

64 *Sodium Hydride*, Na_2H_2 . When dry hydrogen gas is passed over fused sodium at a temperature between 300° and 400° and under a pressure of 760^{mm} the metal gradually absorbs 237 times its volume of hydrogen. The compound obtained possesses a metallic lustre and a silver-white colour; its specific gravity is 0.959; it is soft at the ordinary temperature and it fuses at a somewhat lower temperature than sodium. It may be fused in hydrogen without undergoing any decomposition, but when heated to 330° it begins to evolve hydrogen gas, and if heated in a Sprengel's vacuum pump, the whole of the hydrogen is given off. In this way Troost and Hautefeuille¹ were able to determine the composition of the compound. One volume of sodium disengaged 237 volumes of hydrogen; the volume required by the formula Na_2H_2 being 238.

SODIUM AND OXYGEN.

65 Sodium forms two well defined oxides, a strongly basic monoxide Na_2O , and a peroxide Na_2O_2 . In addition to these a grey suboxide probably exists, formed when a clear surface of the metal is first exposed to air.

Sodium Monoxide, Na_2O . Sodium does not oxidize in perfectly dry air, but when heated it takes fire and burns with formation of a mixture of the monoxide and peroxide. In order to obtain the pure monoxide sodium hydroxide is heated with sodium;

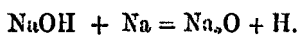

It is a grey mass having a conchoidal fracture; it melts at a

¹ *Ann. Chim. Phys.* [5], ii. 272.

dull red heat and undergoes volatilization at a still higher temperature (Davy). Its specific gravity is 2.805. When brought into contact with water violent action occurs, sodium hydroxide being formed.

Sodium Hydroxide, Sodium Hydrate, or Caustic Soda, NaOH. When water is added to sodium monoxide or to the peroxide of sodium great heat is evolved, and the hydroxide is formed, in the latter case oxygen being liberated. The hydrate is also formed when sodium is thrown on to water. In order to prepare it in this way a piece of clean sodium of the size of a small nut is thrown into a silver basin containing a few drops of water, and kept cool in cold water. A second piece of metal is then added, and a little more water, and so on, until about a pound of metal has been used. Great care is needed in this operation, as the fused soda is apt to be thrown about. The solution is evaporated and the soda obtained in a fused state cast into sticks.¹ The hydroxide thus obtained is free from chloride, and sulphate of sodium, and from alumina, silica, and oxide of iron. It is, however, an expensive material used only for special purposes in the laboratory.

For the purpose of preparing a cheaper material use is made of the decomposition which sodium carbonate in dilute solution undergoes in presence of quick-lime. On the small scale 3 parts of soda crystals are dissolved in 15 parts of boiling water and a quantity of milk of lime, obtained by slaking 1 part of lime with 3 parts of water, is added little by little to the boiling liquor. The liquid after boiling is tested from time to time, and when found free from carbonic acid, treated as has been described under caustic potash.

Caustic soda is a white opaque brittle solid with fibrous texture. Its specific gravity is 2.13 (Filhol), and it melts below a red heat and is rather less volatile than potash. It deliquesces in the air and when moist absorbs carbon dioxide, and acts as a powerful caustery. When heated to the melting point of cast-iron, caustic soda decomposes into its elements (Deville).²

Hydrated Caustic Soda, $2\text{NaOH} + 7\text{H}_2\text{O}$. This hydrate is deposited in large transparent tabular crystals when a solution of soda-ley of specific gravity 1.365 is exposed to a temperature of -8° . These crystals melt at 6° , yielding a liquid having a specific gravity of 1.405 (Hermes).³

¹ *Engineer*, 1867, p. 225.

² *Comptes rendus*, xlv. 857.

³ *Fogg. Ann.* cxix. 170.

According to G. Rose these crystals belong to the monoclinic system.¹

Soda-ley. The following table gives the specific gravity of soda-ley at 15°, according to the experiments of Schiff.²

Percentage of NaOH.	Specific Gravity.	Percentage of NaOH.	Specific Gravity.
1	1·012	30	1·332
5	1·059	35	1·384
10	1·115	40	1·437
15	1·170	45	1·488
20	1·225	50	1·540
25	1·279	55	1·591
		60	1·643

Caustic soda is a most useful substance, and is largely used for many industrial processes, its chief employment being in the manufacture of soap. A description of the method used for its preparation on the large scale will be found in the sequel.

Sodium Dioxide, N₂O₂. Sodium when heated in oxygen oxidizes in the same way as potassium, and sodium dioxide is formed (Harcourt).³ This oxide is also formed when sodium nitrate is ignited (Gay-Lussac and Thénard).

Sodium dioxide has a pure white colour, but it becomes yellow on heating, regaining its white tint when cold. When exposed to the air it deliquesces, then absorbs carbonic acid, and ultimately forms a solid mass of carbonate. The dioxide is not decomposed on heating; when thrown into water, heat is evolved and caustic soda and oxygen formed; if the water be added gradually the dioxide dissolves, and this solution if allowed to evaporate spontaneously deposits large tabular hexagonal crystals of the hydrate, Na₂O₂ + 8H₂O, and these when dried over oil of vitriol lose three-fourths of their water, giving rise to a second hydrate, Na₂O₂ + 2H₂O. Sodium dioxide absorbs carbon monoxide gas with formation of sodium carbonate:



Carbon dioxide is likewise absorbed, and then one atom of oxygen is liberated:

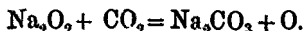

¹ *Loc. cit.*

² *Ann. Pharm.* cvii. 300.

³ *Chem. Soc. Journ.* xiv. 276.

The first hydrate is also precipitated when alcohol is added to a mixture of the aqueous solutions of caustic soda and peroxide of hydrogen. For this purpose a solution of caustic soda containing 20 per cent. of NaOH is mixed with one of hydrogen peroxide containing 5 per cent. of H_2O_2 , and alcohol of 80 per cent. added in excess. The precipitated hydrated peroxide can be filtered and dried without decomposition (Fairley).¹

When sodium dioxide is heated with phosphorus, brilliant incandescence occurs. The dioxide combines with nitric oxide when heated nearly to its melting-point, sodium nitrite being produced.

SALTS OF SODIUM.

65 *Sodium Chloride, or Common Salt*, NaCl. Davy states that sodium takes fire when brought into chlorine gas. Wanklyn² has, however, shown that dry chlorine does not attack sodium even in the melted state. Probably Davy's chlorine was moist. Metallic sodium also retains its brightness in liquid chlorine at -80° .

Chloride of sodium occurs as rock-salt in large deposits in various geological strata, in solution in sea-water and brine springs, and in small quantities in all running water.

The chief European deposits of salt occur in the trias formation. The most important are those at Northwich and Winsford in Cheshire, at Wielizca in Galicia, at Reichenhall, Hallein, and other localities in the Tyrol, and at Stassfurt in the north of Germany. Rock-salt also occurs in France, Spain, and Switzerland, and in Asia, Africa and America, in various localities.

The Cheshire salt-beds occur in mountain limestone. They are two in number, separated by about 30 feet of clay; they are together about 20 yards thick, 300 yards broad, and a mile and a half long.

The methods adopted for raising and working the salt differ widely, according to the nature of the deposit and its situation. Sometimes the rock-salt is mined and brought up to the surface; generally, however, salt-springs or brine-wells are artificially constructed by sinking a bore-hole through the overlying strata to the salt-bed, and allowing water to pass down this boring. The water soon becomes saturated with salt, and it is then

Chem. Soc. Journ. 1877, i. 125.

² *Chem. News*, xx. 271.

pumped up and the salt obtained by evaporation, either by means of fuel or by exposure to air.

Owing to the presence of cheap fuel and water carriage the quantity of salt raised in England is much larger than that obtained in any other country. No less than 1,500,000 tons of salt were obtained from English brine in the year 1876, and in addition about 176,000 tons were raised as rock-salt.

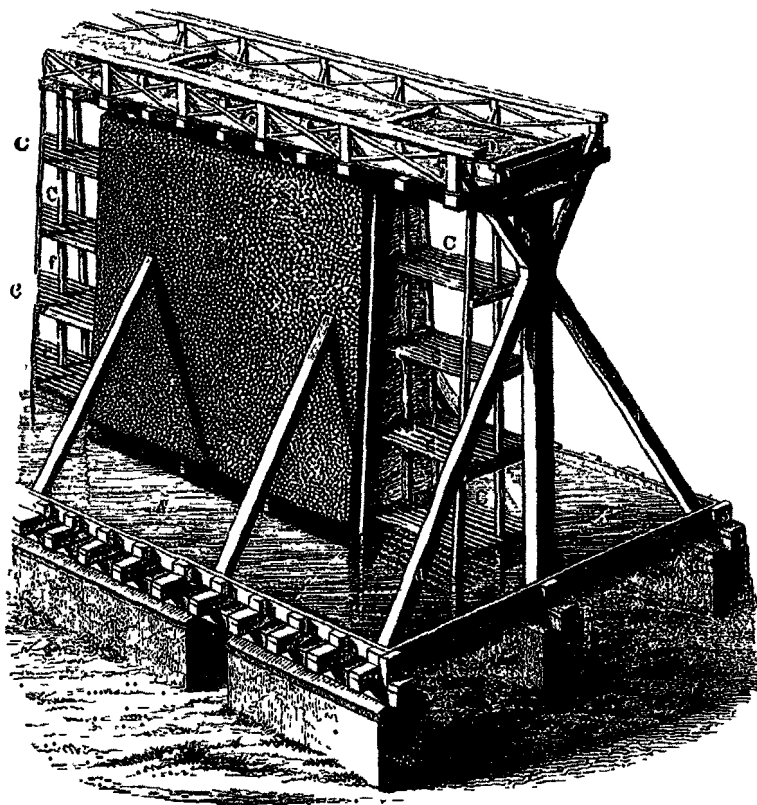

FIG. 14.

67 The process of evaporating the brine, 100 parts by weight of which in Cheshire usually contain 23.3 parts of salt, is of the simplest kind. Indeed it has not been improved since the time of the Romans, and although very numerous patents for the purpose have been taken out, no economy in fuel has been

effected. The brine is evaporated in large shallow iron pans heated by means of fires placed beneath. The appearance and quality of the salt which deposits depends upon the temperature at which the brine is kept and the rapidity with which the process of evaporation is conducted. One ton of salt needs for its production the consumption of about 10 to 12 cwt. of slack or small coal. The Cheshire brine contains about 1.65 per cent. of calcium sulphate, CaSO_4 , and about 0.05 per cent. of magnesium chloride, MgCl_2 . The first of these salts is deposited as pan-scale when the brine is boiled down.

In Germany, where fuel is dear, the brine is evaporated by exposing it to the action of the air by a process termed "graduation." After having been allowed to trickle several times over high walls of fagots and thus become more concentrated, it is boiled down in pans. The arrangement used for this purpose is shown in Fig. 12.

Preparation of Salt from Sea-water. The evaporation of sea-water in salterns, or brine-pans, by the aid of air and the sun's heat has been carried out from very early times. In England, at Hayling Island near Portsmouth, and at Lymington, and in Scotland at Saltcoats on the Ayrshire coast, such salterns are now in use.

In countries more favoured by sunshine, such as the coasts of France, Portugal and Spain, these salterns are more numerous than with us. When this salt, termed Bay-salt, is deposited, a mother-liquor called Bittern is left. This consists of the chlorides, sulphates, and bromides of magnesium and potassium, and from this, bromine is obtained.

All common salt contains a small quantity of sodium sulphate, calcium sulphate, and magnesium chloride. The presence of the last compound renders the salt liable to become damp in the air. This same substance likewise not unfrequently attacks the iron pans, causing the presence of traces of ferric chloride in the salt.

In order to prepare chemically pure sodium chloride from common salt, hydrochloric acid gas is passed into a saturated solution of salt. A precipitate of the pure chloride is thrown down, the alkaline sulphates and magnesium chloride remaining in solution. The precipitate is thrown on a filter, washed with concentrated hydrochloric acid, and then dried and fused in a platinum basin.

Properties.—Sodium chloride crystallizes in cubes. Rock-

salt is usually found in cubical crystals, sometimes, however, in octohedrons and intermediate forms. It possesses an agreeable saline taste. Its specific gravity at 0° is 2·16, and its hardness 2·5. Rock-salt is highly diathermanous, or it permits the heat-rays, dark as well as visible, to pass through it. Hence it is a valuable substance in thermal researches. Sodium chloride melts at 776° (Carnelley), and crystallizes on cooling. It begins to volatilize at temperatures not far removed from its melting point, and hence it cannot be fused without loss (Stas).

When heated with silicic or boric acid, sodium chloride is decomposed, with liberation of hydrochloric acid and formation of a silicate or borate. It has been proposed to utilize the former of these reactions for the manufacture of carbonate of soda, but without practical success. Sulphuric acid decomposes it, hydrochloric acid, and hydrogen sodium sulphate being formed.

According to the experiments of Poggiale,¹ one hundred parts of water dissolve the following quantities of sodium chloride at the corresponding temperatures:—

Temp.	0°	5°	14°	25°	40°	60°	80°	100°	109°·7	
NaCl.	5·5	2	35·63	35·87	36·13	36·64	37·25	38·22	39·16	40·35

Hence sodium chloride is not, as was formerly supposed to be the case, equally soluble in cold and in hot water. The specific gravity of salt solutions of different strengths is, according to Gerlach,² as follows:—

Percentage of NaCl.	5	10	15	20	25
Specific Gravity at 15°.	1·03624	1·07335	1·11146	1·15107	1·19228

Brine containing 26·27 parts of salt in 100 boils at 108°·8 when the thermometer is placed in the liquid (Guthrie).

Chloride of sodium dissolves in aqueous alcohol, although nearly insoluble in absolute alcohol; the solubility increases in this case regularly with the temperature.

When the temperature of a saturated solution of sodium chloride is lowered to - 10° a crystalline hydrate separates out³ having the composition $\text{NaCl} + 2\text{H}_2\text{O}$. When brine is further cooled to - 22° acicular bundles of crystals separate out. These

¹ *Ann. Chim. Phys.* [3], viii. 469.

² Gerlach, *Zeitschr. Analyt. Chem.* viii. 279.

³ Lowitz, *Croll. Ann.* 1793, i. 314.

when remelted at different times, show that the cryohydrate $\text{NaCl} + 10\text{H}_2\text{O}$ is formed (Guthrie).¹

Ekman in his investigation² on the composition of sea-water found that the amount of sodium chloride in sea-water can be obtained by a simple calculation if the specific gravity of the brine at 15° be given. For this purpose it is only necessary to multiply the four first decimals of the specific gravity with the number 0.013. Thus a specific gravity of 1.0166 gives a percentage of 2.16 of NaCl, a number closely agreeing with that obtained from Gerlach's tables.

68 *Sodium Bromide*, NaBr, and *Sodium Iodide*, NaI, are prepared by processes similar to those employed in the case of the corresponding potassium salts. Like these latter the sodium salts crystallize from their hot concentrated solutions in anhydrous cubes, whilst if the solutions be allowed to evaporate at the ordinary temperature, monoclinic prisms are deposited. These contain two molecules of water of crystallization and are isomorphous with the corresponding hydrate of sodium chloride.

Sodium Hypochlorite, NaOCl. This compound is only known mixed with sodium chloride, in the liquid obtained by passing chlorine into a solution of caustic soda. This was formerly known as chloride of soda or Labarraque's liquor.

Sodium Chlorate, NaClO_3 . This salt is obtained by neutralising carbonate of soda with aqueous chloric acid, or by boiling nine parts of chlorate of potash with seven parts of sodium silico-fluoride. Sodium chlorate crystallizes in regular tetrahedrons, the solution depositing large crystals on cooling. This salt is much more soluble than the corresponding potassium compound. According to Kremers, 100 parts of water dissolve at,

	0°	20°	40°	60°	80°	100°	120°
Parts of NaClO_3	81.9	99	123.5	147.1	175.6	232.6	333.3

The specific gravity of the solutions is as follows:—

Percentage	10	15	20	25	30	35
Specific Gravity	1.070	1.108	1.147	1.190	1.235	1.282

It is also soluble in alcohol. Owing to its great solubility chlorate of soda is now manufactured for the use of the calico-printer in the production of aniline black.

¹ *Phil. Mag.* [4], xlix. 9.

² *Ber. Deutsch. Chem. Ges.* iv. 749.

This salt when heated evolves but little oxygen (Schlössing), and a mixture of sodium chloride and sodium perchlorate, NaClO_4 , is formed. This last salt is extremely soluble in water, and crystallizes in deliquescent tables (Serullas).

69 *Sodium Hyposulphite*, NaHSO_3 . For the purpose of preparing this salt a concentrated solution of acid sulphite of sodium placed in a well-corked bottle is brought into contact with zinc turnings or clippings. The mixture is kept cool and the materials allowed to remain in contact for about half an hour. A white precipitate of zinc sodium sulphite is then deposited, and the clear solution must be poured off into three times its volume of strong alcohol. A bottle is then completely filled with this alcoholic liquid and tightly corked. A second crop of crystals of the last-named salt soon begins to separate out, and as soon as this has deposited, the liquid is again poured off into bottles which are filled and corked as before and then allowed to stand for some hours in a cool place. Sodium hyposulphite soon separates out in the form of fine needle-shaped crystals, which must be quickly pressed between folds of blotting-paper and dried in a vacuum. The salt thus obtained generally contains some zinc sulphite, although pure enough for most purposes. It can be purified by solution in water and reprecipitation by the addition of alcohol.

Sodium hyposulphite is now used by the dyer and calico-printer as a reducing agent for indigo, and it is also used in the laboratory for the purpose of estimating free oxygen or the quantity of that element contained in substances which easily evolve oxygen.

A solution of this salt can readily be obtained for laboratory purposes by digesting zinc clippings for half an hour with a solution of 100 grams of hydrogen potassium sulphite having a specific gravity of 1.245, air being excluded from the solution. It must then be diluted with one liter of water, and 20 grams of caustic lime added in the form of milk. This precipitates the zinc oxide and calcium sulphite, and the clear solution is filled into bottles which are well corked and kept with their necks under water.

70 *Normal Sodium Sulphite*, Na_2SO_3 . The anhydrous salt is obtained by heating a cold saturated aqueous solution of the hydrated salt. The hydrate containing seven molecules of water is obtained by saturating a solution of sodium carbonate with sulphur dioxide and then adding the same quantity of

sodium carbonate. The crystals which are deposited from this solution are transparent, and form prisms belonging to the monoclinic system. They dissolve slightly in aqueous alcohol, and when heated to 150° lose the whole of the water. The solution has an alkaline reaction and a sharp taste.

Crystals of the hydrate, $\text{Na}_2\text{SO}_3 + 10\text{H}_2\text{O}$, are obtained, according to Muspratt, by allowing the aqueous solution to evaporate over sulphuric acid.

Hydrogen Sodium Sulphite, NaHSO_3 . If a solution of sodium carbonate be saturated whilst cold with sulphur dioxide, this salt separates out in turbid crystals, and alcohol precipitates it from its aqueous solution as a white powder. It has an acid reaction, smells of sulphurous acid, and has an unpleasant sulphurous taste.

Sodium Disulphite, $\text{Na}_2\text{S}_2\text{O}_5$, is a white soluble salt, obtained in a similar manner to the corresponding potassium compound.

71 Normal Sodium Sulphate, Na_2SO_4 . This compound is commonly known in the anhydrous state by the commercial name of *Salt-cake*, whilst the hydrate, $\text{Na}_2\text{SO}_4 + 10\text{H}_2\text{O}$, is called Glauber's salt. We find the first mention of this salt in Glauber's work *De naturâ salium*, published in 1658. He obtained it as the residue left in the preparation of hydrochloric acid by the action of oil of vitriol upon common salt, and believed this simple aperient to be possessed of most valuable medicinal properties, whence it came to be known as *Sal mirabile Glauberi*.

The salt occurs native in the anhydrous condition as thénardite, and in solution in sea-water and in the water of salt-lakes, as well as in large quantities in certain mineral springs. Thus the water at Friedrichshall contains large quantities of this salt, which since 1767 has been obtained by evaporation and used in medicine as *Sal aperitivum Fridericianum*. A native compound of sodium sulphate with calcium sulphate termed glauberite is also found in several localities.

Sulphate of soda is prepared on an enormous scale as salt-cake, the first step in the manufacture of carbonate of soda, no less than 700,000 tons having been produced in the year 1876 in the United Kingdom. For this purpose common salt is decomposed either by sulphuric acid or by the combined action of sulphur dioxide, air, and aqueous vapour. The details of

these processes will be described under the head of the soda manufacture.

Sulphate of sodium is also obtained as a residue in many chemical operations, especially in the preparation of nitric acid from Chili saltpetre in the sulphuric acid manufacture.

If ordinary Glauber's salt be allowed to remain exposed to the air, or more quickly if heated, the anhydrous salt is obtained, and if a solution of Glauber's salt saturated at about 35° be slightly heated, rhombic crystals of the anhydrous salt separate out. These are identical in form with crystals of thénardite, and isomorphous with those of silver sulphate, Ag_2SO_4 . Sodium sulphate possesses a saline bitter taste, has a neutral reaction, and does not dissolve in alcohol. When heated on charcoal before the blowpipe, sodium sulphide is formed. The specific gravity of the solid salt after fusion at a red heat is 2.6313.

72 Hydrated Sodium Sulphate. The deca-hydrate, $Na_2SO_4 + 10H_2O$, commonly known as Glauber's salt, crystallizes from aqueous solution at the ordinary temperature in large colourless monoclinic prisms (Fig. 13), which are isomorphous with chromate and selenate of sodium. These crystals effloresce on exposure to dry air, they melt in their water of crystallization at 33°, and lose the whole of it below 100°. One hundred parts of water dissolve the following quantities of the anhydrous salt:—



FIG. 13.

	At 0°	10°	20°	30°	34°	40°
Na_2SO_4	5.02	9.00	19.40	40.00	55.00	48.8
	At 50°	60°	70°	80°	90°	103°.5
Na_2SO_4	46.7	45.3	44.4	43.7	43.1	42.2

From these numbers it is seen that a maximum of solubility occurs about 34°. Above this point the deca-hydrate begins to decompose and the anhydrous salt is formed, and the solubility of this is less at high than at low temperatures. According to Loewy, sodium sulphate can dissolve in three conditions, in water, either as the deca- or hepta-hydrate, or as the anhydrous salt. The saturated solution boils at 103°.5.

Glauber's salt readily forms supersaturated solutions. These crystallize suddenly, when a small crystal of the salt is thrown into the liquid, or when the solution is cooled down to -8°

This rapid solidification is accompanied by a considerable rise of temperature.

The Hepta-Hydrated Salt, $\text{Na}_2\text{SO}_4 + 7\text{H}_2\text{O}$, is deposited in hard, clear, rhombic crystals when a supersaturated solution of the deca-hydrate is allowed to cool below 12° , or when such a solution is covered with a layer of warm alcohol of specific gravity 0.835.

73 Hydrogen Sodium Sulphate, NaHSO_4 . This salt, commonly known as bisulphate of soda, is obtained in large triclinic prisms when equivalent quantities of sodium sulphate and sulphuric acid are dissolved in water and the solution evaporated at a temperature above 50° . Like the corresponding potassium salt it is decomposed by alcohol at once into sulphuric acid and the normal salt. A hydrated salt, $\text{NaHSO}_4 + 2\text{H}_2\text{O}$, is also known.

Sodium Disulphate, $\text{Na}_2\text{S}_2\text{O}_7$, is formed by heating sulphur trioxide together with common salt (Rosenstiel):—

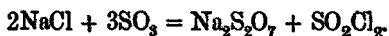

The same compound is formed by the gentle ignition of acid sodium sulphate. When more strongly heated, it yields sulphur trioxide and normal sulphate.

Sodium Thiosulphate, $\text{Na}_2\text{S}_2\text{O}_3 + 5\text{H}_2\text{O}$. This salt, discovered in 1799 by Chaussier, and better known by its old name of hyposulphite of soda, is prepared on the large scale for use as an antichlor in the paper manufacture, and as a solvent for the unaltered silver chloride in photography. It is obtained by boiling sulphur with soda-ley, and passing sulphur dioxide into the yellow solution until it is colourless, or by boiling sodium sulphite with sulphur. A cheaper process is to decompose the soluble calcium thiosulphate obtained by the oxidation of alkali-waste, either by means of sodium carbonate or sodium sulphate. The solution of sodium thiosulphate is drawn off from the carbonate or sulphate of calcium and evaporated down in iron pans.

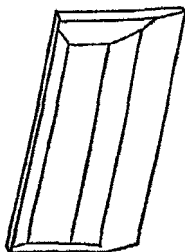

FIG. 14.

Sodium thiosulphate forms large transparent prisms belonging to the monoclinic system shown in Fig. 14. The salt is odourless, possesses a cooling taste, does not give an alkaline reaction, nor does it undergo alteration in the air. The crystals melt in their own water at 45° , and

when heated to 215° all the water is driven off, whilst at 220° they decompose with separation of sulphur (Pape). The salt has a specific gravity of 1.672, is very soluble in water, but does not dissolve in alcohol.

The aqueous solution cannot be preserved for any length of time without decomposition, as it deposits sulphur and is partially converted into sulphate. Sodium thiosulphate is represented by the formula $\text{SO}_2 \begin{cases} \text{ONa} \\ \text{SNa} \end{cases}$.

When treated with sodium amalgam it yields sodium sulphite and sodium sulphide :—

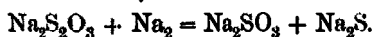

74 *Sodium Nitrate*, NaNO_3 . This salt, commonly known as cubic saltpetre or Chili saltpetre, is of special historical interest as it was by the examination of differences in crystalline form exhibited by this compound and ordinary nitre that the distinction between the alkalis potash and soda was first observed by Bohn in 1683. Boyle, somewhat later, noticed that cubic saltpetre was formed in the preparation of aqua regia from common salt and nitric acid, and Stahl first pointed out the distinct character of the alkali-basis of common salt, and fully described the preparation of cubic saltpetre.

Sodium nitrate occurs in nature as a wide-spread deposit in the rainless districts of South Peru and Bolivia. In these beds it is associated with common salt, gypsum, and sodium sulphate, the crude material containing from 27 to 65 per cent. of the pure salt. This is purified by solution and crystallization. After refining, the salt contains about 97.7 per cent. of pure nitrate, 1.84 of sodium chloride, 0.35 of sodium sulphate, and 0.11 of water.

The best mode of separating out the last 2 per cent. of sodium chloride is to add to the boiling and saturated solution one-tenth of its weight of nitric acid, stir it until cool, and collect the precipitated nitrate, which may then be washed by a dilute acid and afterwards dried.

Sodium nitrate crystallizes in obtuse rhombohedrons, whose interfacial terminal edge angle is 106° 36' (Fig. 15), and is therefore isomorphous with calc-spar. The isomorphism of these two salts can be clearly shown by suspending a crystal of calc-spar in a saturated solution of sodium nitrate, when the crystal will increase in size from the deposition of the latter salt.¹ According

¹ Sénarmont, *Comptes Rendus*, xxxviii. 105.

to the view formerly held, viz., that salts are formed by the union of an acid with a basic oxide, this isomorphism could not be explained, since the two salts must then be assumed to have a different constitution, the one being $N_2O_5 + Na_2O$, and the other $CO_2 + CaO$. This difficulty is removed when we employ the formulæ now in use, viz., $CaCO_3$ and $NaNO_3$, which contain the same number of atoms in the molecule.

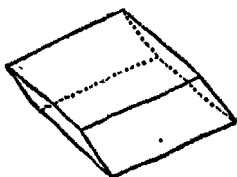

FIG. 15.

The specific gravity of the salt is 2.26. It melts without decomposition at $310^{\circ}5$ (Person), 330° (Carnelley), and when ignited undergoes decomposition

with evolution of oxygen, nitrogen and nitrous fumes. It is very soluble in water, and deliquesces when exposed to moist air. 100 parts of water dissolve:—

At - 5°	0°	10°	20°	40°	60°	80°	100°	111°
Parts 68.8	72.9	80.8	87.5	102	122	148	180	200

This salt also dissolves in alcohol. 100 parts of spirit, containing 61.4 per cent. of alcohol, dissolve at 26° 21.2 parts of sodium nitrate. It does not deflagrate so violently as nitre with charcoal or other inflammable bodies, but it has sometimes been used for making blasting and other powders which are not required to fire quickly.

Sodium nitrate is largely used in the manufacture of nitric acid as it is much cheaper than nitre; it is also employed as an ingredient in artificial manures and especially as a top-dressing for barley.

Sodium Hypophosphite, $NaH_2PO_2 + H_2O$. This salt is obtained by adding sodium carbonate to a solution of calcium hypophosphite, and allowing the solution to evaporate in a vacuum. Pearly tabular crystals are deposited, which deliquesce on exposure to the air, and are easily soluble in absolute alcohol. It is now employed in medicine for the same purposes as phosphorus.

75 Sodium Phosphates. These well-defined salts exhibit clearly the characteristic properties of phosphoric acid. From Graham's researches we first learnt that phosphoric acid exists in three modifications:—

Orthophosphoric Acid.	Pyrophosphoric Acid.	Metaphosphoric Acid.
H_3PO_4	$H_4P_2O_7$	HPO_3

Each of these can be converted into either of the other compounds, and to each corresponds a series of salts, viz.:—tribasic orthophosphates, tetrabasic pyrophosphates, and monobasic meta-phosphates. As the acids, so the salts of one series can be transformed into those of another series.

Sodium Orthophosphates. As orthophosphoric is a tribasic acid, three sodium salts exist according as one, two, or three atoms of the hydrogen in the acid are replaced by metal:—

(1) Trisodium or normal sodium orthophosphate, $\text{Na}_3\text{PO} + 12\text{H}_2\text{O}$.

(2) Hydrogen disodium orthophosphate, $\text{Na}_2\text{HPO}_4 + 12\text{H}_2\text{O}$.

(3) Dihydrogen sodium orthophosphate, $\text{NaH}_2\text{PO}_4 + \text{H}_2\text{O}$. These all give yellow precipitates of trisilver phosphate Ag_3PO_4 , when their solutions are brought into contact with silver nitrate.

Normal Sodium Orthophosphate, Na_3PO_4 .—This salt, first described by Thomson¹ as phospho-carbonate of soda, is prepared by adding at least half as much caustic soda as it already contains to a solution of the next salt, common phosphate of soda, and evaporating to the point of crystallization. The hydrated salt crystallizes out, the mother-liquid retaining only the excess of caustic soda. The crystals freed from the liquor are rapidly dissolved in twice their weight of hot water, the liquid filtered, and then left to crystallize (Graham). The anhydrous salt may be obtained by fusing common phosphate of soda, or pyrophosphate, with an excess of carbonate of soda. The pyrophosphate is not altered by boiling with caustic soda (Graham).

The crystals, which contain 12 molecules of water, form thin six-sided prisms, which do not change on exposure to air, and have a specific gravity of 1.618. They melt at $76^\circ.7$, and at 100° lose all but one molecule of water, which is given off at a red-heat. 100 parts of water at $15^\circ.5$ dissolve 19.6 parts of the salt.

Nitrate of silver produces a yellow precipitate of trisilver phosphate:—

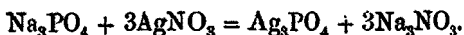

Di-hydrogen Sodium Orthophosphate, Na_2HPO_4 . This salt is the common phosphate of soda, which was first prepared from urine, and described in 1740 by Haupt under the name of *sal mirabile perlatum*. It was afterwards obtained by neutralizing phosphoric acid with soda, and in 1787 was introduced as a medicine by

¹ *Ann. Phil.*, xxvi. 381.

Pearson. It occurs in the blood of animals, and especially in the urine of the carnivora. It is best prepared from bone phosphoric acid by adding carbonate of soda so long as effervescence occurs. The precipitated phosphates of calcium and magnesium

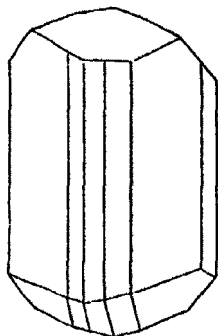

FIG. 16.

are then filtered off, and the liquid boiled down and allowed to crystallize. The large transparent crystals which deposit are monoclinic prisms (Fig. 16) containing 12 molecules of water of crystallization. They have a specific gravity of 1.525, and melt at 35°, and are isomorphous with the corresponding sodium hydrogen arsenate $\text{Na}_2\text{HAsO}_4 + 12\text{H}_2\text{O}$. Exposed to air the crystals effloresce, but do not lose their form; and when dried over sulphuric acid at the ordinary temperature, or when gently heated to 45°, they lose all their water of crystallization.

The following is the solubility of this salt in 100 parts of water:—¹

At	0°	10°	20°	30°	40°	50°	60°	70°
Na_2HPO_4	2.5	3.9	9.3	24.1	63.9	82.5	91.6	95.0
	80°	90°	99°					
	96.6	97.8	98.8.					

The saturated solution freezes at $-0^{\circ}45$, and boils at 105°.

This salt is insoluble in alcohol; it possesses a cooling saline taste, and turns red litmus solution blue. When brought into contact with nitrate of silver solution, a yellow precipitate of yellow trisilver phosphate is thrown down, and the solution becomes acid from liberation of one-third of the nitric acid (Clark):—



Common phosphate of soda is used as a mild purgative. The commercial salt frequently contains sulphate of soda as an impurity. This can be removed by recrystallizing the phosphate from hot water.

Di-hydrogen Sodium Phosphate, NaH_2PO_4 . To prepare this salt phosphoric acid is added to a solution of common phosphate of soda, until the mixture no longer precipitates chloride of barium.

¹ Mulder, *Selcidtekund. Verhand.* 1864, p. 100.

It is then evaporated to small bulk, and allowed to stand for some days to crystallize (Mitscherlich). This salt is dimorphous; two kinds of large transparent crystals separate out, both of which belong to the rhombic system, and contain 4 molecules of water, but which are distinguished by difference in the lengths of their axes.

The crystals have an acid reaction, and a specific gravity of 2.04. They lose all their water of crystallization at 100° and at 204° lose one molecule of constitutional water (Graham) with formation of acid pyrophosphate :—



At 240° they give off the whole of their water and form monometaphosphate :—



Di-hydrogen sodium phosphate is very soluble in water, but not in alcohol. Silver nitrate produces a yellow precipitate of trisilver phosphate, and two-thirds of the nitric acid is liberated :—



Sodium Pyrophosphates. These salts are tetrabasic. They give white precipitates with silver nitrate of silver pyrophosphate, $\text{Ag}_3\text{P}_2\text{O}_7$. They do not coagulate albumin. Their solutions when boiled with an acid, yield tribasic salts.

Normal Sodium Pyrophosphate. $\text{Na}_4\text{P}_2\text{O}_7 + 10\text{H}_2\text{O}$. This salt is obtained in the anhydrous state as a colourless glassy mass by igniting the common phosphate of soda. When it is dissolved in water, and the solution evaporated, crystals of the decahydrate are deposited in monoclinic prisms. The solution has an alkaline reaction. It is not converted into ortho-salt by boiling alone, but this conversion takes place rapidly on addition of an acid, even acetic, to the boiling solution (Stromeyer). When gently heated, or exposed over sulphuric acid in a vacuum, it loses all its water. 100 parts of water dissolve the decahydrate as follows :—

At 0°	10°	20°	30°	40°	50°	60°	80°	100°
5.41	6.81	10.92	18.11	24.97	33.25	44.07	63.40	93.11

Di-hydrogen Sodium Pyrophosphate, $\text{Na}_2\text{H}_2\text{P}_2\text{O}_7$. This salt is prepared by heating the common tribasic phosphate to 150° with strong hydrochloric acid, or by heating the tribasic di-hydrogen

salt to a temperature of from 190° to 204° , when it loses two molecules of water (Graham). It may also be prepared by dissolving the normal pyrophosphate in acetic acid and precipitating by alcohol. It is thus obtained as a white crystalline powder, easily soluble in water. The solution has an acid reaction.

Sodium Metaphosphates. These salts, which were first discovered by Graham, are monobasic, and are remarkable as existing in several polymeric modifications possessing very different properties. With silver nitrate, their solutions give white precipitates of silver metaphosphate, AgPO_3 . They are distinguished from the pyrophosphates inasmuch as they yield a white precipitate with albumin. They do not give a yellow precipitate with molybdate of ammonia until an orthophosphate is formed by the presence of free nitric acid. The sodium metaphosphates are as a rule soluble in water; the mono-metaphosphate, discovered by Maddrell, is an exception to this rule, as it does not dissolve in water.

Sodium Monometaphosphate, NaPO_3 , is always formed when caustic soda is strongly heated with a slight excess of phosphoric acid.¹ It is likewise obtained by heating the di-hydrogen orthophosphate for some minutes to redness; the residue is for the most part insoluble, and consists of monometaphosphate (Graham). When two parts of nitrate of sodium are fused with one part of syrupy phosphoric acid, a dense white powder is left on washing the fused mass with water. This salt, though insoluble in water, is soluble in acids, and on boiling with caustic soda it is transformed into the orthophosphate (Maddrell).²

Sodium Dimetaphosphate, $\text{Na}_2\text{P}_2\text{O}_6 + 2\text{H}_2\text{O}$. This salt is obtained by decomposing copper di-metaphosphate with a boiling solution of sodium sulphide. One part of this salt dissolves in 7.2 parts of water, and crystallizes in fine needles. This metaphosphate possesses a strong tendency to form double salts. Thus a salt having the following composition, $\text{NaKP}_2\text{O}_6, \text{H}_2\text{O}$, is obtained when the mixed solutions of the simple salts are crystallized.³

Sodium Trimetaphosphate, $\text{Na}_3\text{P}_3\text{O}_9 + 6\text{H}_2\text{O}$. This salt is sometimes termed the crystallizable metaphosphate. It is prepared, according to Graham, by exposing microcosmic salt, $\text{Na}(\text{NH}_4)\text{HPO}_4 + 4\text{H}_2\text{O}$, to a moderate heat, or, according to Fleitmann

¹ Fleitmann, *Pogg. Ann.* lxxviii. 361.

² *Chem. Soc. Journ.* iii. 373.

³ Fleitmann, *Pogg. Ann.* lxxviii. 246.

and Henneberg,¹ by allowing the fused salt to cool slowly. Fine crystals may be obtained by allowing the concentrated solution to evaporate spontaneously in a shallow vessel. They form triclinic prisms which dissolve in 4.5 parts of cold water. The solution in cold water is permanent and is neutral, but on boiling it soon becomes acid from formation of the hydrogen orthophosphate.

Sodium Tetrametaphosphate, $\text{Na}_4\text{O}_4\text{P}_4\text{O}_8 + 4\text{H}_2\text{O}$. Prepared by decomposing the corresponding lead salt with sodium sulphide. The sodium salt forms a thick gum-like solution which filters with difficulty. On evaporation a transparent colloidal mass is obtained. When heated it is converted into the next salt.

Sodium Hexametaphosphate, $\text{Na}_6\text{O}_6\text{P}_6\text{O}_{12}$. This, often called deliquescent, vitreous, or Graham's metaphosphate, is prepared by fusing either the di-hydrogen orthophosphate or microcosmic salt. The melted mass must be quickly cooled, as if cooled slowly trimetaphosphate may be formed. This dissolves easily in water; the solution possesses a slightly acid reaction, and if evaporated at 38° leaves a gummy mass. The aqueous solution does not undergo any change, even when boiled with caustic soda. Sodium hexametaphosphate is very readily soluble in alcohol.²

76 Sodium Arsenates. These salts closely resemble the corresponding phosphates. An impure arsenate of sodium is prepared on the large scale by dissolving arsenic trioxide in caustic soda, and adding sodium nitrate. The solution is boiled down, and the residual mass heated in a furnace until it appears to be perfectly dry. This product is largely used in calico-printing as a substitute for cow-dung, which was formerly employed in clearing the cloth after mordanting. The mordant consists of a solution of acetate either of aluminium or iron, and the cloth, after having been printed with these mordants, is hung up and exposed to air. In this, which is termed the *ageing process*, a portion of the acetic acid evaporates, leaving basic acetates of iron and aluminium firmly attached to the fibre of the cloth. A portion of these salts is, however, mixed up with the thickening or starch which must be added to the mordant in order that the impression shall be clear. To remove this excess of unfixed mordant, the cloth is subjected to a peculiar treatment termed the *dunging process*. For this purpose it will not answer merely to wash the cloth in pure water, because the soluble

¹ *Ann. Chem. Pharm.* lxx. 307.

² Graham, *Phil. Trans.* 1833.

portion of the mordant is then removed from the printed pattern, but attaches itself again to the unmordanted cloth, which it is intended should remain white. Long ago it was observed by the native dyers and calico-printers in India that if cow-dung be added to the washwater the excess of mordant can be removed without any staining of the cloth occurring. The action of the cow-dung in this process has not yet been satisfactorily explained, but experience has shown that sodium arsenate solution acts in a similar way, and at the present time the old process is generally superseded by the use of what is known in the trade as "dung substitute."

BORATES OF SODIUM.

Sodium Orthoborate, Na_3BO_3 . When boron trioxide is fused with excess of caustic soda, three molecules of water are expelled and the above salt remains:—¹

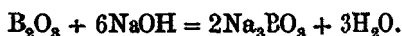

This salt is very unstable, indeed it cannot exist in solution, for when dissolved in water it is transformed into a hydrated metaborate.

Sodium Pyroborate, or Borax, $\text{Na}_2\text{B}_4\text{O}_7$. The history of this the most important of the borates is lost in obscurity. It has already been stated under boron² that in the Latin translation of Geber's works the word borax or baurach occurs, but whether or not this indicated the substance which we now call by that name is a mere matter of speculation. Even up to the end of the seventeenth century nothing certain was known either as to the source or the composition of borax, which was used as a flux, and which was early brought into European markets by the Venetians. It was not until 1747 that an exact knowledge of its composition was arrived at, when Baron pointed out that borax consists of a compound of boric acid (then called sedative salt) and soda. This salt exists combined with five and with ten molecules of water as well as in the anhydrous state. The decahydrate $\text{Na}_2\text{B}_4\text{O}_7 + 10\text{H}_2\text{O}$, is found native, as *tincal*, in several localities, especially in Thibet, California, and Peru. Before the discovery of the boric acid lagoons, the whole of the borax of commerce was obtained, at Venice and Amsterdam, from Asiatic tincal, which was refined by a simple process long

¹ Bloxam, *Journ. Chem. Soc.* xiv. 143.

² Vol. I. p. 541.

kept secret. This consisted in recrystallizing the crude salt after washing and boiling it with lime or caustic soda, for the purpose of removing the greasy matters with which the tincal, for some purpose or other, is usually covered.¹

The greater part of the borax now used is made by fusing or boiling the crude Tuscan boric acid with half its weight of soda-ash, Na_2CO_3 . In France it is usual to boil the two substances together and allow the borax to crystallize. In England the mixture of boric acid and soda-ash is calcined in a reverberatory furnace. The fused mass is then lixiviated with warm water in iron pans, and the borax allowed to crystallize.

Another source of borax is the mineral boronatrocalcite, $\text{Na}_2\text{B}_4\text{O}_7 + 2 \text{CaB}_4\text{O}_7 + 18 \text{H}_2\text{O}$, termed in commerce borate of lime or "tiza," found in the nitrate of soda beds in South America, and in the massive condition in Nevada. The mineral is decomposed with hydrochloric acid and the liberated boric acid treated as above.

Much borax is also obtained from the borax lake in California. One pound of crystallized borax is contained in thirteen gallons of this water. Large deposits of crystallized borax occur at the bottom of the lake, and in its neighbourhood is a spring which contains 103 grains of borax per gallon.²

Anhydrous Borax or Borax Glass is best obtained on the small scale by fusing 124 parts of crystallized boric acid with 53 parts of dry carbonate of soda. A transparent glass is thus obtained having a specific gravity of 2.367, which becomes opaque on exposure to air from absorption of water.

Fused borax glass dissolves many metallic oxides which impart their peculiar colours to the glass. Hence this substance is largely used in blowpipe analysis, and also in the arts for preparing a clean metallic surface for soldering metals.

This amorphous or glassy borax is readily soluble in water, but insoluble in alcohol. It forms two important hydrates.

Octohedral Borax, $\text{Na}_2\text{B}_4\text{O}_7 + 5\text{H}_2\text{O}$. This salt is deposited when a supersaturated borax solution is allowed to evaporate spontaneously in a warm place. This solution is prepared by dissolving three parts of the decahydrate (common borax) in four parts of warm water. Another plan is to dissolve borax in boiling water until the specific gravity of the solution rises to 1.246, and then allow the solution to cool. The crystallization

¹ New Analysis of Tincal, by Vohl, *Wagn. Jahrb.* xvii. 322.

² Campbell, *Chem. News*, 1870, p. 90.

of octohedral borax begins when the temperature reaches 79° , and continues until it sinks to 56° , after which common borax deposits. The crystals are hard transparent regular octohedrons, having a specific gravity of 1.815.

Common, or Prismatic Borax, $\text{Na}_2\text{B}_4\text{O}_7 + 10\text{H}_2\text{O}$. Anhydrous borax when exposed to moist air absorbs ten molecules of water and forms this salt. The decahydrate is deposited from solutions at all temperatures below 56° , in the form of large transparent monoclinic prisms (Fig. 17), which have a specific gravity of 1.71. When heated in the air the crystals swell up, losing their water and forming a spongy mass called *borax usta*, or burnt borax. The crystalline form of natural borax is shown in Fig. 18.

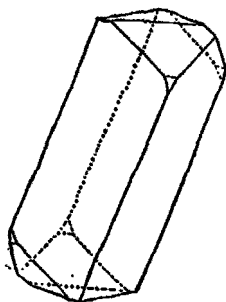

FIG. 17.

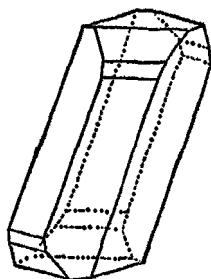

FIG. 18.

The impurities usually found in commercial borax are carbonate of soda, traces of the sulphates and chlorides of the alkali-metals, and salts of magnesium and calcium. Sometimes it is adulterated with alum and common salt. Pure borax gives no effervescence with acids, and dissolves in two parts of hot water. The solution is not rendered turbid on addition of alkali, and does not give a precipitate either with barium chloride or silver nitrate. According to Poggiale,¹ 100 parts of water dissolve at—

0°	10°	20°	30°	40°	50°
2.83	4.65	7.88	11.90	17.90	27.41
60°	70°	80°	90°	100°	
40.43	57.85	76.19	116.66	201.43	
parts of $\text{Na}_2\text{B}_4\text{O}_7 + 10\text{H}_2\text{O}$.					

¹ *Ann. Chim. Phys.* [3] viii. 467.

The aqueous solution has a slight alkaline reaction, the light yellow colour of turmeric paper being turned brown by it.

Sodium Metaborate, $\text{NaBO}_2 + 4\text{H}_2\text{O}$. This salt is formed when borax is fused with the requisite quantity of carbonate of soda. The fused mass when dissolved in water deposits monoclinic crystals having the above composition.

76 Silicates of Sodium. While when carbonate of potash and silica are fused together, potassium metasilicate is always obtained, if sodium carbonate in excess be employed, *sodium trisilicate*, $\text{Na}_3\text{Si}_3\text{O}_{10}$ is formed, three molecules of silica liberating four molecules of carbon dioxide. If equal molecules of silica and sodium carbonate be fused together, *sodium metasilicate*, Na_2SiO_3 , is obtained. This salt dissolves in water and on evaporation the solution deposits crystals of a hydrated salt, which contain seven molecules of water.¹

Sodium Tetrasilicate, $\text{Na}_2\text{Si}_4\text{O}_9$. Commonly known as silicate of soda or soluble glass. It is prepared by heating together 180 parts of white sand, 100 of calcined soda-ash, and 3 of charcoal in a reverberatory furnace. Another method consists in dissolving powdered flint under pressure in a hot concentrated solution of caustic soda. Prepared by the first method it forms a transparent glassy mass, sometimes colourless, but generally of a yellow, brown, or green colour, which when powdered readily dissolves in boiling water to form a thick viscid liquid. Silicate of soda is employed in fixing fresco colours by the process of stereochromy. It is also employed as a cement in the manufacture of artificial stone. This is made by mixing the solution with sand and lime; it is likewise used as a cement for joining the broken surfaces of porcelain, stone, &c. Another purpose for which soluble glass is employed is as an addition to soap. The so-called silicated soap, first introduced by Mr. William Gossage, is now prepared in large quantities by adding a solution of this compound to the soap whilst setting.

Sodium Silico-fluoride, Na_2SiF_6 , is prepared in a similar way to the potassium compound, and is very similar to this latter salt; 100 parts of water dissolve at $17^\circ.5$, 0.652 parts of the salt, and at 101° , 2.459 parts (Stolba).

¹ Yorke, *Phil. Trans.* 1357, p. 540.

CARBONATES OF SODIUM.

77 *Normal Sodium Carbonate*, Na_2CO_3 , commonly known as carbonate of soda, or soda-ash, is prepared on an enormous scale as the chief product of the alkali manufacture, a most important branch of industry. Anhydrous sodium carbonate, or soda-ash, is a white opaque porous mass, or a white powder, having a specific gravity of 2.5, which fuses at a moderate red-heat to a clear liquid, a small quantity of carbon dioxide being liberated. Sodium carbonate possesses an alkaline taste and reaction, but less strongly marked than potassium carbonate. When brought into contact with water it combines with the water, heat being evolved. If a tolerably concentrated hot solution of carbonate of soda be allowed to cool, large transparent monoclinic prismatic crystals are deposited (Fig. 19). These are commonly termed soda-crystals or washing soda, or the decahydrate, and possess the formula $\text{Na}_2\text{CO}_3 + 10\text{H}_2\text{O}$, and have the spec. grav. 1.45. These crystals dissolve in water with evolution of heat; they melt at 34° , with formation

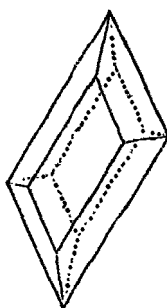

FIG. 19.

of a second hydrate, $\text{Na}_2\text{CO}_3 + \text{H}_2\text{O}$. The decahydrate crystals effloresce on exposure to air, forming a white powder of the monohydrate. The decahydrate occurs native, as natron, together with the monohydrate, known as thermonatrite, in the soda-lakes of Egypt and Hungary, and also at Vesuvius and Etna, and various parts of Asia, Africa, and America.

The *heptahydrate*, $\text{Na}_2\text{CO}_3 + 7\text{H}_2\text{O}$, crystallizes in rhombohedra when a warm saturated solution is allowed to cool in absence of air. Several other hydrates are known. The formation and decomposition of these various hydrates at different circumstances of temperature cause a similar anomaly in the solubility of sodium carbonate in water, as was noticed in the case of Glauber's salt. 100 parts of water dissolve at—

	0°	10°	20°	30°	32.5°
Na_2CO_3	7.1	12.6	21.4	38.1	59 parts.

Above this last temperature the solubility of sodium carbonate diminishes, so that between 32° and 79° a constant quantity, viz.

46·2 parts, dissolve in 100 of water. At higher temperatures the quantity dissolved is—

	80°	90°	100°	105°
Na_2CO_3	46·1	45·7	45·4	45·1

Commercial anhydrous carbonate of soda always contains sodium chloride and sulphate, as well as caustic soda and other impurities. Soda crystals are usually much purer, and may be obtained perfectly free from impurity by repeated crystallization.

Hydrogen Sodium Carbonate, HNaCO_3 . This salt, commonly known as bicarbonate of soda, is likewise prepared on a large scale. It occurs in commerce in the form of a white crystalline powder, or in crystalline crusts which consist of monoclinic tables. It possesses a faint alkaline taste, and dissolves less readily in water than the normal salt. 100 parts of water dissolve at—

	0°	10°	20°	30°	40°	50°	60°	70°
HNaCO_3	7·92	8·88	9·84	10·80	11·76	12·72	13·68	14·64

A solution of the bicarbonate gives off carbon dioxide on boiling, and the solid salt decomposes on ignition into carbon dioxide, water and the normal salt:—

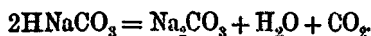

Commercial bicarbonate of soda almost always contains some normal carbonate, and this may be removed by washing with small quantities of water; but, on drying, the residual salt is found again to contain some normal carbonate. A better method is to moisten the washed salt with alcohol, and then to dry it between folds of filter paper without application of heat. Even then it undergoes partial decomposition, and contains about one per cent. of the normal carbonate. In order to detect the presence of the latter salt in the bicarbonate, 1·0 gram of the salt under examination is mixed with 0·5 gram of mercurous chloride and 1·5 gram of water. This mixture is shaken in a stoppered bottle. If the normal salt be absent this mixture remains white for twenty-four hours; if this impurity be present, the liquid becomes of a more or less grey tint.¹

Trona, or *Urao*, is a carbonate of soda occurring native in Hungary, Egypt, Fezzan in Africa, India, and America. It is a

¹ Hager, *Anal. Zeitschr.* ix. 631.

compound of the normal with the bi-carbonate, and has the formula $\text{Na}_2\text{CO}_3 + 2\text{HNaCO}_3 + 3\text{H}_2\text{O}$. This is the body to



FIG. 20.

which the ancients gave the name *nitrum*. It occurs in small monoclinic crystals (Fig. 20), and it can be prepared artificially by boiling a solution of bicarbonate of soda and then allowing

it to cool, when crystals of this salt separate.

THE ALKALI MANUFACTURE.

78 The history of the manufacture of carbonate of soda, or soda-ash, from common salt is one of peculiar interest. Previous to the year 1793 the whole of the carbonate of soda of commerce was obtained from the ashes of sea-plants, called varec or kelp, collected on the north-west coasts of France, Ireland, and Scotland. The quantity of alkali thus obtained from sea-plants was, however, much less than that which came to Western Europe from Russia and America in the form of potashes, the characteristic alkali of land-plants.

One of the first effects of the French Revolution was to cut off this supply of the latter alkali from France, and, therefore, to diminish important manufactures dependent upon its use. Under these circumstances the French Government of the day issued an appeal to the French chemists urging the importance of obtaining all the materials deposited in their own country by nature, "so as to render vain the efforts and hatred of despots;" and commanding all citizens who "have commenced establishments or who have obtained patents for the manufacture of soda from common salt, to make known to the Convention the locality of these establishments, the quantity of soda supplied by them, and the quantity they can hereafter supply." A Commission was appointed to investigate this subject, and in 1794 they reported on thirteen different processes for the manufacture of soda-ash from common salt, the particulars of which had been submitted to them. The preference was given to the operations devised by an apothecary of the name of Leblanc, who had already erected a soda manufactory near Paris, which had been at work for some time previously. The report gives a full description of the various processes which constituted Leblanc's invention. These consisted of—

(1) The salt-cake process, or that of the decomposition of com-

mon salt by means of sulphuric acid, and the consequent production of sulphate of soda, with evolution of hydrochloric acid gas.

(2) The black-ash process, or that of the decomposition of the sulphate of soda or salt-cake by means of chalk and coal, and the consequent production of black-ash, consisting essentially of a mixture of soluble carbonate of soda, (Na_2CO_3), and insoluble calcium monosulphide (CaS).

(3) The separation of the constituents of the last product by lixiviation with water and the preparation of the soluble carbonate of soda.

This process, elaborated by Leblanc before the French Revolution, is in fact that now employed in all alkali-works, and, unlike most technical processes, has undergone no material alteration. The Commissaires say in their report:—"Citizens Leblanc, Dizé, and Shée were the first who submitted to us particulars of their process, and this was done with a noble devotion to the public good." Their establishment had been formed some time previously at Franciade; but the consequences of the French Revolution and of the war which followed having deprived them of funds, the works were suspended, and after the lapse of some time the manufactory became a national establishment and was successfully at work in the year 1794. The operations however did not proceed satisfactorily, the quantity of soda turned out was smaller than had been expected, the manufacture was discontinued, and Leblanc and his partners applied for and received assistance from the English Government. It is sad to have to relate that the man who thus originated a world-wide industry, and to whom we owe cheap soap and cheap glass, did not benefit from his discoveries, but died in a French asylum for paupers.

Other alkali works in France were more successful than Leblanc's original manufactory. Several of these were situated at Marseilles, the seat of the French soap trade, and conveniently placed for obtaining three of the necessary raw materials; (1) sulphur, imported from Sicily; (2) salt, obtained by the evaporation of salt-water by the sun's heat; (3) limestone;—it was however at the disadvantage of being at a distance from coal.

Although the process for making alkali was published in the *Annales de Chimie* for the year 1797, it is remarkable that seventeen years elapsed before this process was taken up in England by Mr. Losh. This may be accounted for by the fact that as war was then raging, communication between the two

countries was almost entirely cut off, but perhaps especially because of the high war-duty on salt which existed up to the

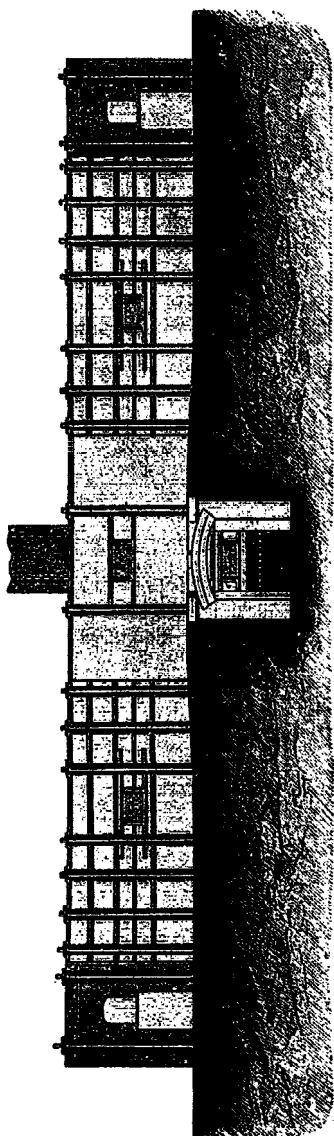

FIG. 21.

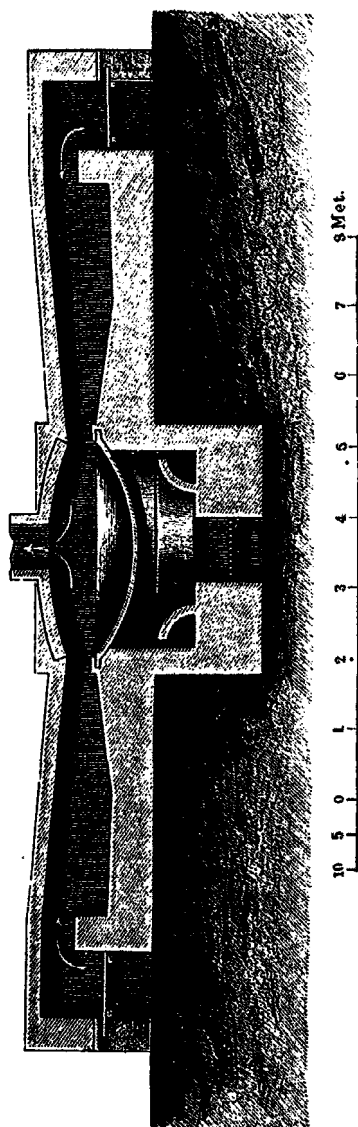

FIG. 22.

year 1823. The difference in cost of production is well shown

by the fact that in 1814 soda crystals cost £60 per ton whilst in 1861 the price of the same article was £4 10s. per ton.

The year 1823 may really be considered the one in which the alkali trade began, inasmuch as in that year, Mr. James Muspratt began the erection of works at Liverpool, at once adopting Leblanc's process.

79 (1.) *The Salt-cake Process.*—This process is usually commenced in large cast-iron pots, and completed in reverberatory furnaces or roasters. Fig. 21 shows the elevation of an ordinary salt-cake furnace; Fig. 22 shows the same furnace in longitudinal section; Fig. 23 is a horizontal section, whilst Fig. 24 shows a cross-section through the line H G. It consists of a large covered semicircular iron pan built in the centre of the furnace and heated by a fire underneath, and two roasters or reverberatory furnaces heated by fires placed one at each end, on the hearths of which furnaces the salt is completely decomposed.

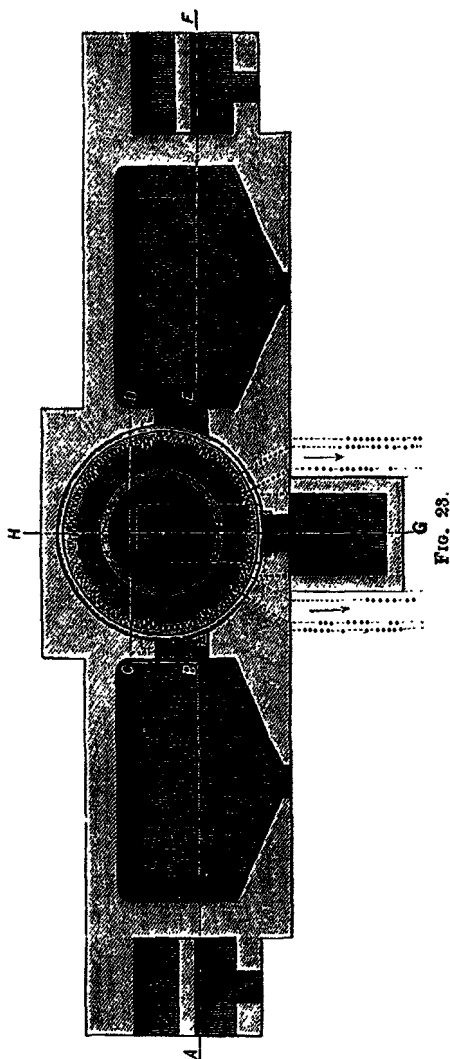

It consists of a large covered semicircular iron pan built in the centre of the furnace and heated by a fire underneath, and two roasters or reverberatory furnaces heated by fires placed one at each end, on the hearths of which furnaces the salt is completely decomposed.

The charge consists of 16 cwt. of common salt, which is placed in the iron pan through the door (A, Fig. 24), and on to this the quantity of sulphuric acid necessary completely to decompose it is run from the reservoir (D, Fig. 24). This amounts to 123.5 gallons, or 1,800 lbs. of chamber acid having a specific gravity of 1.42. Torrents of hydrochloric acid are then given off, the decomposition which takes place being represented by the equation :



This process lasts about one hour, and the temperature of the mass rises to about 50°. All the hydrochloric acid which is thus evolved passes directly from the pan by means of the

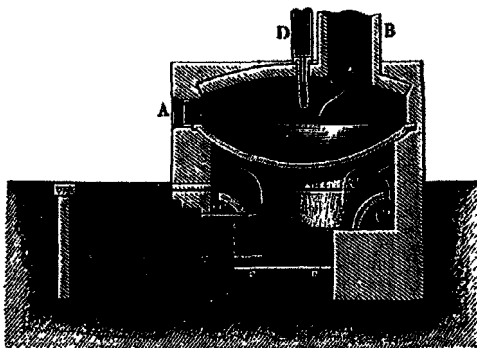

FIG. 24.

flue (B, Fig. 24), into the hydrochloric acid condensing towers (Fig. 25). These towers are often 50 or 60 feet in height, and are usually built of Yorkshire flag clamped together with iron, the joints being rendered gas-tight by a cord of vulcanized rubber. The acid vapours enter the first tower direct from the salt-cake pan; and in passing up this tower, which is either filled with piled bricks or with hard coke, it meets with a descending current of water supplied from the cistern at the top. The strongly acid liquors flow away by a pipe at the bottom of the tower, and are stored by the manufacturer for subsequent use. Any hydrochloric acid vapours unabsorbed in the tower pass down a brick tunnel into the second tower, which they ascend and meet another current of falling water. When the vapours reach the top of this tower they ought to be perfectly free from

hydrochloric acid gas, and are then allowed to pass away into the chimney.

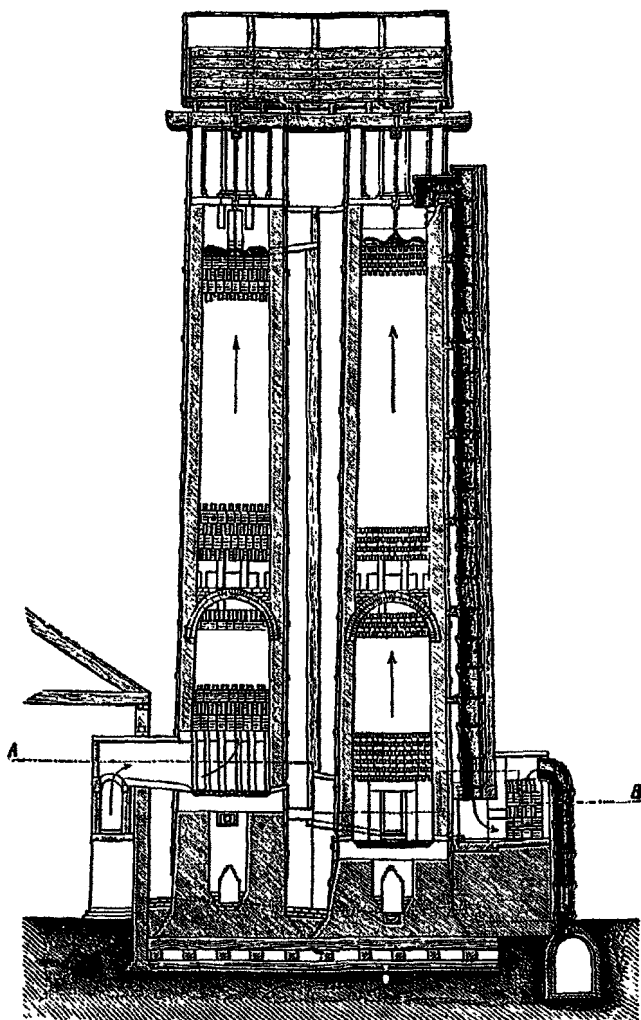
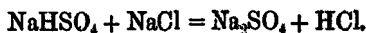

FIG. 25

After the mixture has been heated for about an hour in the salt-cake pan and has become solid, it is raked on to the hearth of one of the furnaces or roasters at each side of the decomposing pan. Here the hot air and flame from the fire at the end complete

the decomposition into sodium sulphate and hydrochloric acid :



The acid vapours here evolved pass, together with the products of combustion of the fire, into the same condensers as the pan-acid, and there are all condensed to liquid. As soon as the decomposition is complete the salt-cake is withdrawn from the furnace and kept for the subsequent process. Ten of the above charges are usually drawn in one day, so that 8 tons of salt, and about the same weight of oil of vitriol, are used, whilst nearly 5 tons of gaseous hydrochloric acid and nearly 20 tons of salt-cake are formed. The following is a complete analysis of an average sample of commercial salt-cake :—

COMPOSITION OF SALT-CAKE.

Normal sodium sulphate	95.275
Hydrogen sodium sulphate	1.481
Sodium chloride	1.354
Calcium sulphate	0.923
Ferric oxide and insoluble matters	0.321
Water	0.187
			99.541

The furnaces just described are termed *open* roasters, in opposition to the second kind of salt-cake furnace to which the name of *close* roasters is given. In the first kind all the acid vapours, both the concentrated acid from the pan, and the roaster acid which is much diluted with air and products of combustion, pass into the same condenser. In this method of working it is difficult, therefore, to get a very strong acid, and much annoyance is caused by the condensers becoming choked with soot and dust from the fires.

Hence the second method is employed in many works. The pan, as shown in A, Fig. 26, is built at the side of the roaster instead of being placed in the centre, and the acid from the first part of the decomposition, being concentrated and unmixed with air, passes by a long well-jointed earthenware pipe into a condenser (C, Fig. 26), where a saturated or fuming aqueous hydrochloric acid is prepared, whilst the gases from the roaster (B, Fig. 26) are separated from the products

of combustion by inclosing the hearth of the furnace by a

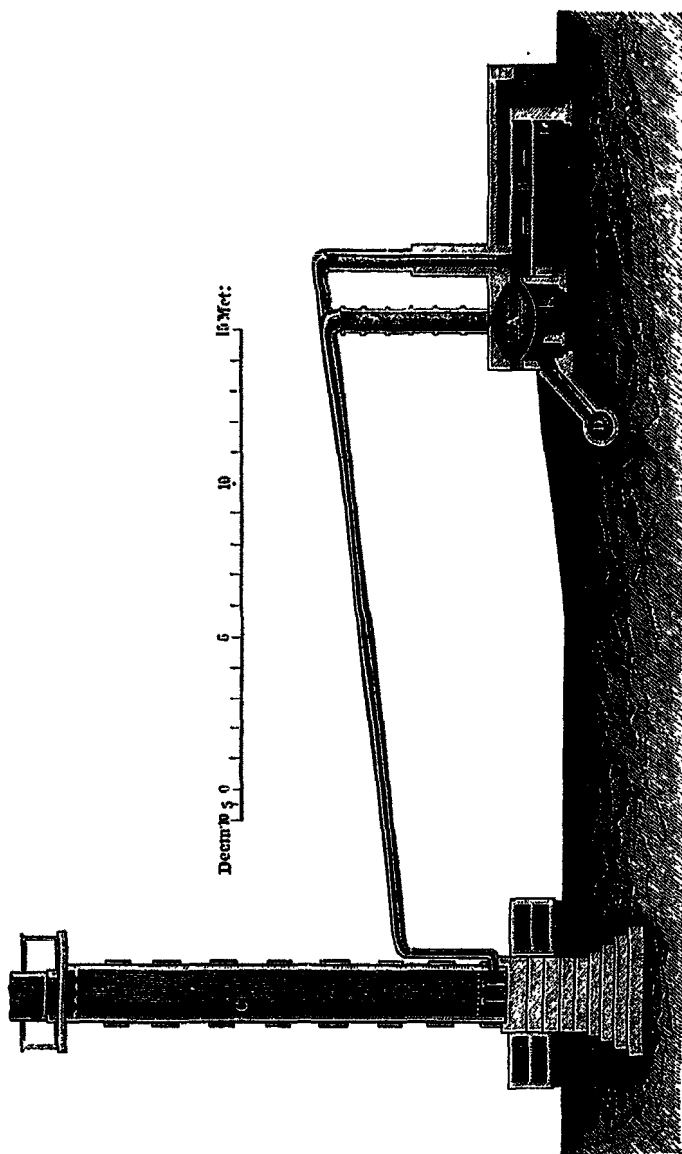

FIG. 26.

fire-brick arch, between which and the top of the furnace the

flames and hot air from the fire pass. Thus the salt-cake is placed on the hearth of a kind of brick chamber or muffle (B), being simply heated by radiation from the hot arch at the other side of which the fire-gases pass, so that no soot or dirt from the fire can be carried into the condensers, and these do not become clogged or choked, and thus a more perfect condensation is rendered possible; D shows the flue for carrying away the fire-gases from the pan and roaster. But unfortunately these advantages are not wholly unaccompanied by drawbacks, which if not important for the manufacturer, are at least serious to his neighbours. The arch separating the roaster-hearth from the fire-gases cannot practically be kept gas-tight; it is continually cracking from unequal expansion, and as soon as a crack occurs, the hydrochloric acid gas is pulled or drawn by the draft

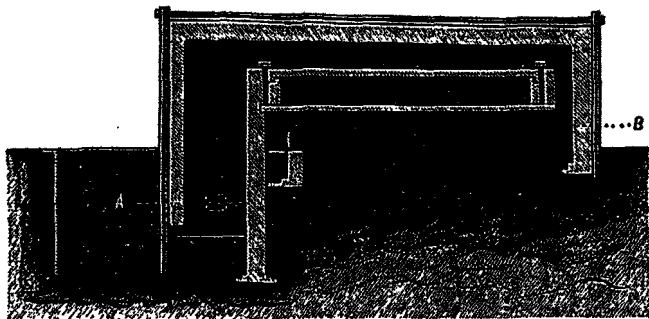

FIG. 27.

of the chimney through the crack, and thus passes up the chimney where the pressure is somewhat less than that of the atmosphere, and is delivered into the air, rather than passing through the condensers, where the pressure is somewhat greater than the atmosphere. This is a fertile source of annoyance in the neighbourhood of alkali-works. Several suggestions have been made with a view of obviating this difficulty in the use of the closed roasters. One of the most feasible and ingenious of the proposed schemes is that patented by the late Mr. Deacon of Widnes. Figs. 27 and 28 show the construction of this furnace in section and in plan. The fireplace is built contiguous to, but several feet below, the brick chamber or muffle in which the acid gas is evolved. It follows from this difference of level that there is a column of heated gases several feet in height immediately over the fire-

bars, and the upward movement of this heated and rarefied air receives a check in going round the muffle, so that the ordinary state of things is reversed, and the pressure in the flue round the muffle is greater than that in the interior of the muffle, thus altogether preventing any chance of escape of the acid vapours from the muffle to the chimney, though allowing some of the gaseous products of combustion to pass through the unavoidable cracks into the interior of the muffle, but in such small quantity that they do not interfere at all with the successful working of the condensation. In Fig. 28, B shows the position of the salt-cake pot, and A is the flue carrying the products of combustion to the chimney. It is probable that before long either this or some similar salt cake furnace will come into general use.

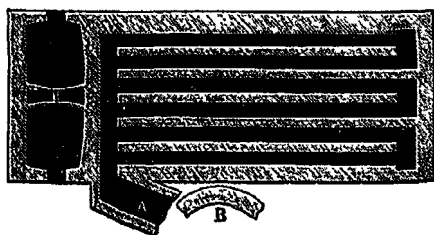

FIG. 28

We owe another valuable and quite recent improvement in the salt-cake process to Messrs. Jones and Walsh of Middlesborough. This consists in a mechanical arrangement by which all hand-labour is dispensed with, and by which the whole operation, from the mixing of the materials to the production of the finished dry salt cake, is carried on in one large pan.

A third proposal, made by Messrs. Cammack and Walker, seems to be based upon a more scientific view of the decomposition than any of the former plans. When large masses of salt and sulphuric acid are brought together, the reaction is at first very violent, and torrents of hydrochloric acid gas are evolved. The action however soon moderates: during the first ten minutes the main quantity of acid has come off, and during the remaining forty minutes needed to complete the reaction, probably only a small quantity of gas enters the condensers. So that for ten minutes the condensers have more work than they can properly perform, whilst after that time they are underworked. Messrs.

Cammack and Walker's plan seeks to obviate these inconveniences of all the old processes by sending in, at one end of the heated space in which the reaction occurs, a constant stream of salt and acid mixed in the right proportions, and drawing off at the other end the finished salt-cake. Thus a never increasing and never decreasing stream of hydrochloric acid is sent into the condensers and a constant supply of the solid product is furnished. In this way the reaction can be most completely kept under control, and all irregularities and therefore chances of escape of acid vapours rigidly prevented. How far this plan can be practically carried out remains yet to be ascertained, but this appears to be the most scientifically correct proposal yet made for the manufacture of salt-cake from sulphuric acid and common salt.

Another important process for manufacturing salt-cake is that which from the name of the inventor is termed the *Hargreaves process*. The object of this is to manufacture salt-cake directly from salt, sulphur dioxide and water, so as altogether to dispense with the manufacture of sulphuric acid; and it depends upon the fact that although sulphur dioxide cannot by itself decompose salt, it is able to do so in the presence of oxygen and water, if time enough be allowed. In order to effect this decomposition, a series of large kilns or stoves, built of brick, are so arranged that each kiln can be put into communication with its neighbour, and each heated by a fire. Each kiln is then filled with dried and porous salt (NaCl), and the gases from the pyrites burners led directly into these kilns one after the other. By careful attention to temperature and to the quantity of air and steam admitted with the sulphur dioxide, it is possible in this way to decompose the salt into sulphate of soda (salt-cake) as perfectly as when heated by the old process with sulphuric acid. The chemical reaction is the same in both cases; hydrochloric acid gas is given off from the Hargreaves' kilns as from the ordinary salt-cake pan or roaster and must in like manner be passed into the condensers :

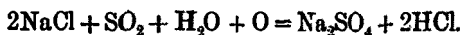

80 (2.) *The Black-ash Process*.—The theory of this process is a simple one, so far as the chief products are concerned, but it is complicated when we come to consider the mode of formation of the many distinct compounds which make their appearance in the course of the reaction.

The first chemical change which the salt-cake (Na_2SO_4)

undergoes in its passage to carbonate of soda is the reduction to sodium sulphide (Na_2S), by heating it with slack, or powdered coal; thus:

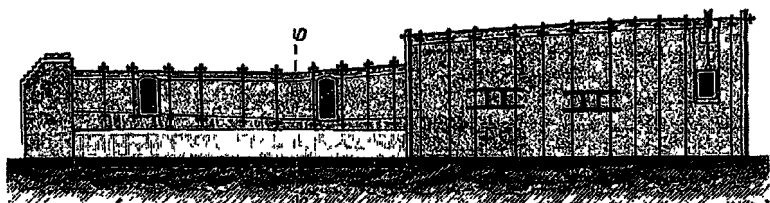
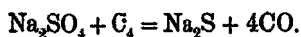

FIG. 29.

The second change which occurs is the conversion of the sodium sulphide into sodium carbonate (carbonate of soda), by

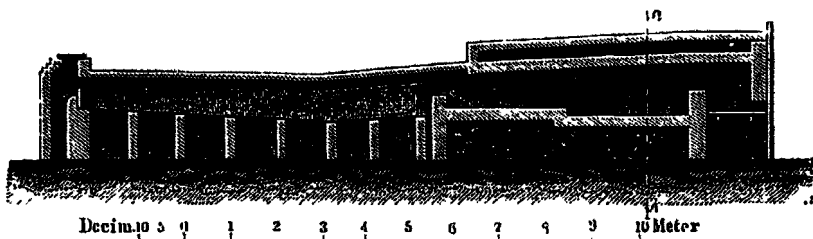
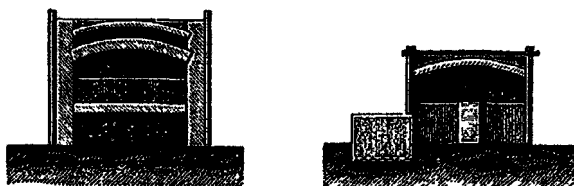
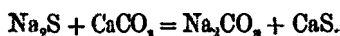

FIG. 30.

heating it with chalk or limestone (calcium carbonate). The reaction which then takes place is represented by the equation:



FIGS. 31 AND 32.

In practice these two reactions are carried on at the same time, a mixture of about 10 parts by weight of salt-cake, 10

parts of limestone, and $7\frac{1}{2}$ parts of coal, being heated in a reverberatory furnace, termed a balling-furnace. Fig. 28 shows the elevation, and Figs. 29, 30, and 31, show longitudinal and

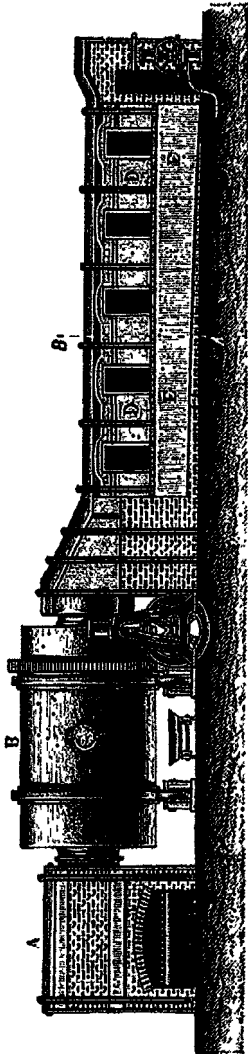

FIG. 33.

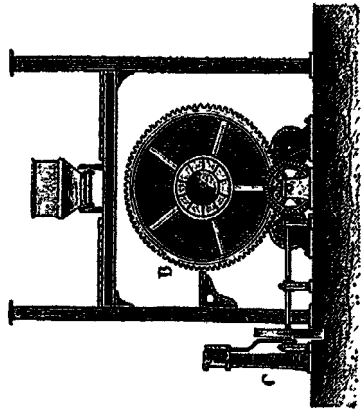

FIG. 34.

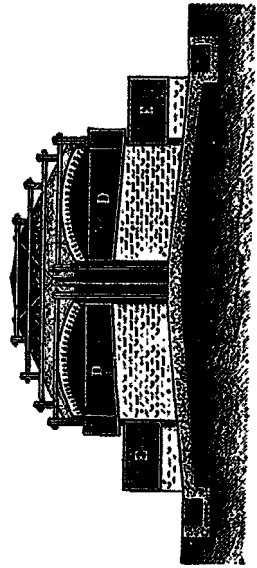

FIG. 35.

transverse sections of such a furnace. After exposure to the reducing flame of this furnace for two hours the charge, consisting of $4\frac{3}{4}$ cwt., is fluxed and fully decomposed, and then the

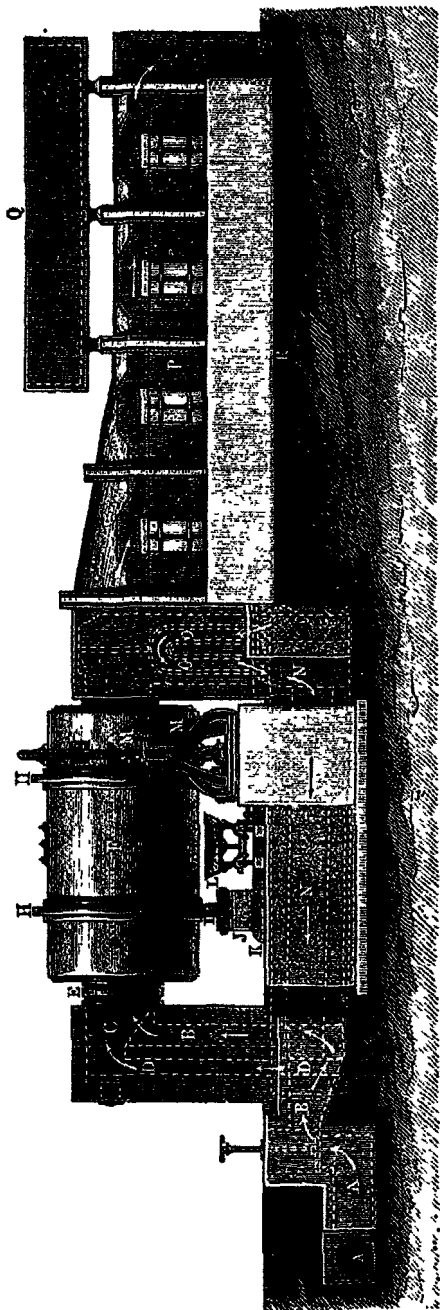

FIG. 36.

liquid mass is scraped out into iron barrows or trucks and allowed to cool, and in this state is known as black-ash ball, so called from the colour of the mass.

In place of the old black-ash furnace or balling-furnace in which the reaction is completed by hand-labour, a new furnace, termed a revolving black-ash furnace, is being now largely employed, the general arrangement of which is shown in Fig. 33. In this the mixing of the materials is effected mechanically. The charge, usually consisting of 30 cwt. of salt-cake, 32 of limestone, and 20 of slack, is introduced by means of a hopper into a large cylinder (B, Fig. 33), placed horizontally, through the axes of which flames from a furnace (A) are allowed to pass; this

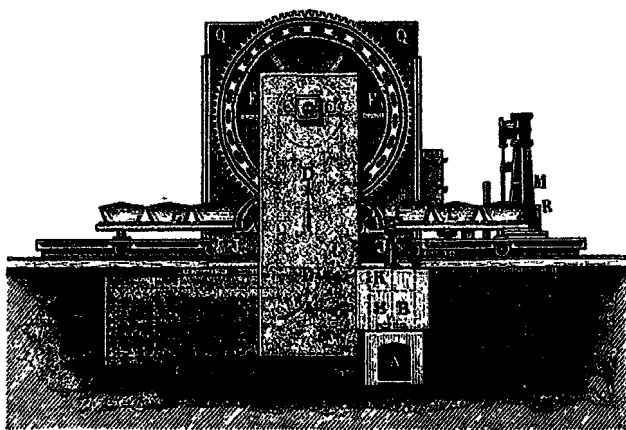

FIG. 37.

cylinder, worked by an engine (C, Fig. 34), revolves first at a slow rate and afterwards with an increasing and maximum velocity of five or six revolutions per minute. The cylinder is from 10 to 12 feet in diameter and from 15 to 18 feet long. Each charge takes about two hours to work off, and when completed a door in the side of the cylinder is opened and the fused mass allowed to flow into iron trucks placed beneath it. It yields 10 balls, each being a small truckful of black-ash, weighing 3 cwt. A more complete form of the black-ash revolver is shown in Figs. 36 and 37. In this arrangement the revolver (F) is fed with gas from a Siemens' gas-furnace, and the regenerators (NN) for the recovery of the waste heat are placed below the revolver.

The advantages which the revolving black-ash furnace has over the hand-worked ones chiefly consist in the saving of labour and in the production of a material which possesses a more constant composition.

The following Table gives the charges, theoretical and practical, of salt-cake, coal, and limestone used in various works :—

BLACK-ASH CHARGES.

No. 1, Lancashire charge—

		Lbs. practice.	Lbs. theory.
Salt-cake	224	224
Limestone	224	158
Coal-dust	140	76

No. 2, Tyne charge—

Salt-cake	196	196
Limestone	252	138
Coal-dust	126	66

The following analyses of black-ash show that this substance contains a large number of other salts besides carbonate of soda and monosulphide of calcium, though these two constitute its main ingredients. In practice a large excess of lime is used and this gives rise to caustic soda in the black-ash.

ANALYSIS OF BLACK-ASH.

No. 1. Is the analysis of an English Black-ash by Kynaston.
 No. 2. " German " Stohmann.
 No. 3. " French " Kolb.

	1.	2.	3.
Sodium carbonate ...	36.88	44.41	44.79
Sodium sulphate ...	0.39	1.54	0.92
Sodium chloride ...	2.53	1.42	1.85
Sodium silicate ...	1.18	—	1.52
Sodium aluminate ...	0.69	—	1.44
Calcium sulphide ...	28.68	30.96	29.96
Lime	9.27	8.35	9.68
Calcium carbonate ...	3.31	3.20	5.92
Ferric oxide	2.66	1.75	1.21
Coal	7.00	5.32	1.20
Calcium sulphite ...	2.18	—	} 1.51
Magnesia	0.25	0.10	
Magnesium silicate ...	—	—	
Alumina	1.13	0.79	
Water	0.22	—	
Ferrous sulphide ...	0.37	—	
Silica	—	0.89	
Sand	0.90	2.20	
Ultramarine	0.96	—	
	98.60	100.93	100.00

An improvement has recently been introduced into the black-ash process by Mr. Mactear by which, instead of using a weight of limestone equal to or greater than the weight of salt-cake, only about 70 parts or one molecule of limestone is employed to 100 parts or one molecule of salt-cake, but in addition to this 6.5 parts of quick-lime is added. By this plan a considerable saving of raw material is effected, and the black-balls are very easily lixiviated, so that this improved process is now being rapidly adopted.

81 (3.) *Lixiviation of the Black-ash.*—The next operation consists in the separation of the carbonate of soda from the insoluble calcium monosulphide, and the other impurities. This is easily effected by the process of *lixiviation*, or

washing out the soluble carbonate of soda, leaving the monosulphide of calcium and the excess of lime and carbonate of lime as insoluble powders behind. In this process the object aimed at is to dissolve as large a quantity of the carbonate of soda with as small a quantity of water as possible. The arrangement of lixiviating vats for effecting this is the invention of the late Mr. Shanks of St. Helens. A series of vats are employed in which the broken black-ash is placed; pure water is allowed to flow on to that portion of the ash which has already been nearly exhausted, and the solution then passes on until the nearly saturated liquors come in contact with the fresh black-ash. In this way the complete lixiviation of the black-ash is effected with the least quantity of water. The average time needed for working off a vat is about forty-eight hours. The residue remaining in the vats after the soluble matter has been extracted constitutes what is known as the alkali-maker's waste. This waste contains the whole of the sulphur from the salt-cake, and as a rule in the insoluble state of monosulphide of calcium. This waste is now thrown away, being either made into heaps which are apt to become a nuisance in the neighbourhood of the alkali-works, or are carried out to sea, or otherwise made away with.

It is impossible, however, by this process of lixiviation completely to wash out the soluble carbonate of soda, so that we find about 3 per cent. of soluble alkali left in the vat-waste.

A considerable excess of limestone is generally used in the manufacture of black-ash, and this in the course of the reaction becomes converted into caustic lime; on treating the mass with water the caustic lime transforms a considerable quantity of the carbonate of soda into caustic soda, and carbonate of lime is formed:



Hence it happens that as a rule about one-third of the total amount of soluble soda present in the black-ash liquor is caustic. Besides this, the black-ash liquor usually contains small quantities of sulphide as well as thiocyanate of sodium. In order to separate the sulphide of sodium as well as the caustic soda which the black-ash liquors contain, these liquors are frequently oxidized and carbonated by the liquid being allowed to fall down towers, filled with coke, up which hot air mixed with carbonic acid passes. In order to evaporate the

black-ash liquors the waste heat of the black-ash furnace is employed. Large pans, shown in D D, Figs. 33 and 35, are filled with the liquor, the water boiled off, and the crystals which are deposited are scraped out into the drainers (E E, Figs. 33 and 35). These crystals are then heated, and yield common soda-ash. This common ash is further purified by exposure to heated air on the floor of a reverberatory- or refining-furnace. In this process any traces of the sulphides are oxidized to sulphates, the caustic alkali carbonated, and the yellowish tint of the common ash, which is due to the presence of sulphide, is got rid of.

Dr. C. R. A. Wright has made a series of experiments on the loss of sodium occurring in the black-ash process. He believes the loss to be as follows:—

Sodium salts undecomposed	3.49 per cent.
Sodium compounds rendered insoluble	5.44 „
Sodium compounds vaporized	1.14 „
	—————
	10.07 „

82 *Caustic Soda* is now manufactured on the large scale in the alkali works. For this purpose the red-liquors are used from which the black-ash crystals have been deposited. These mainly consist of a solution of carbonate of soda and caustic soda in varying proportions, but contain at the same time chloride, sulphate, cyanide, and sulphide of sodium as impurities. The red-liquors are first allowed to pass down a coke tower where they meet with a current of air, and thus the sulphides are oxidized to sulphates. Then having been reduced to a specific gravity of 1.10 they are causticised by heating with milk of lime in large iron boat-pans or boilers. The clear caustic liquor is then run off, the lime-mud being well washed to extract the soluble caustic soda, and these washings being used to dilute fresh quantities of the red-liquors. The dilute caustic liquors are then either boiled down in ordinary steam-boilers or in open pans, and afterwards concentrated in cast-iron flanged pots sufficiently large to hold from 8 to 10 tons of finished caustic soda, being often 9 feet in diameter and 5½ feet deep. These pans are built into brickwork, and are heated by means of a furnace placed either below or on one side. When the temperature reaches 120° the liquor begins to boil, and ammonia gas is evolved from the decomposition of the cyanides. The temperature rises as the liquors become more concentrated, and

as soon as it reaches 260° the pots are loosely covered and the fire then urged until the contents of the pot are raised to a dull red-heat. It is now necessary to oxidize the small quantities of sulphides and cyanides which are still contained in the caustic liquors. For this purpose either nitre is added from time to time, or air is pumped through the hot liquid. If nitre is used torrents of ammonia are evolved, and a black deposit of graphite resulting from the decomposition of the cyanides is formed. The white caustic soda thus prepared contains about 70 per cent. of Na_2O , or nearly 90 per cent. of the hydrate NaOH . A less concentrated product termed "cream caustic" is also made; this contains about 60 per cent. of Na_2O . When the operation of concentration is finished, the fused caustic is ladled out by means of copper ladles into iron drums, where it solidifies on cooling. In this way it can be transported to any distance without undergoing change.

83 Alkali-maker's Waste.—For every ton of soda ash produced from one and a half to two tons of waste is formed; and in the neighbourhood of alkali-works enormous quantities of this waste accumulate. This waste contains the whole of the sulphur burnt in the pyrites kilns, amounting to from 15 to 20 per cent. of the weight of the waste. The importance of recovering this sulphur, not only for the sake of the manufacturers themselves, to whom it is now entirely lost, but also for the sake of diminishing the nuisance to the neighbourhood, is patent to all. The waste, even when carefully stamped down and when the surface is made as hard as possible or even covered with cinders, invariably undergoes oxidation; the insoluble monosulphide of calcium becomes converted into a soluble higher sulphide, and meeting with rain- or drainage-water dissolves, and the solution finds its way into the ordinary drains or streams of a district, and upon meeting with the carbonic acid of the air, or with the acid discharge from the alkali-works, evolves sulphuretted hydrogen sufficient to become a nuisance to the inhabitants of districts lying even several miles away from the waste. Many proposals have been made for recovering the sulphur from the waste. Amongst these, that patented in England by Mr. Ludwig Mond has proved the most successful. This process depends upon the fact that the newly lixiviated waste, being porous and warm, undergoes oxidation when exposed to the action of air, with formation of soluble sulphur compounds, so that, on treating the oxidized waste with

water, not less than half of the total sulphur is obtained in solution in such a condition that, upon acidification with hydrochloric acid, the whole of the sulphur in combination is precipitated in the form of a finely divided yellow powder. The form in which the sulphur dissolves is chiefly as thiosulphate and polysulphides of calcium, and these must be present in such proportions that on treatment with acid two molecules of sulphuretted hydrogen are evolved to one molecule of sulphurous acid; and hence sulphur alone is precipitated without evolution of either of the two gases :

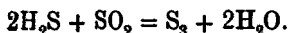

or—

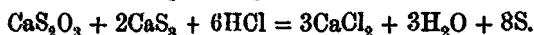

As much as 40 per cent. of the sulphur may, according to Mr. Mond, be thus recovered, but as a rule not more than 25 per cent. is practically obtained. Although this process has been worked on a large scale in many places, it has not as yet been generally adopted by the English alkali-makers. The greatest nuisance experienced in the neighbourhood of alkali works is however due to the evolution of sulphuretted hydrogen gas from the careless or incautious mixing of the drainage containing soluble sulphides with acid liquors from the works. A complete and compulsory separation of alkaline- and acid-drainage liquors in such cases is imperatively called for.

Another sulphur-recovery process, which is particularly applicable to the treatment of the alkaline drainage from old waste-heaps, is that proposed by Mr. Mactear. The yellow liquors thus obtained are mixed with lime and submitted to the action of sulphurous acid. Sulphur is then deposited and calcium hyposulphite formed, whilst some sulphuretted hydrogen is given off. To this liquor fresh yellow-liquor is added in suitable proportions, so that on the addition of hydrochloric acid no sulphuretted hydrogen is evolved, but only sulphur deposited.

84 Other Soda Processes.—Of the numerous proposals which have been made to replace Leblanc's process, only one has proved successful. This process is interesting from the simplicity of the reaction, as also from the fact that no noxious vapours are emitted in any part of the process. It is termed the *Ammonia-soda process*, and is now being carried out on the large scale both in England and on the Continent. It depends on the well-known fact that when carbon dioxide is passed into a solution of common salt in aqueous ammonia, a double

decomposition occurs and the slightly soluble bicarbonate of soda is precipitated :—



The mother-liquors containing the sal-ammoniac are heated with lime or magnesia, and thus the ammonia regained for subsequent use. The only waste product is calcium- or magnesium-chloride, and the latter compound may be decomposed by superheated steam into hydrochloric acid and magnesia, and thus the process is one which is theoretically complete. Notwithstanding the completeness of this plan, years have elapsed before it could be worked economically. The process was patented so long ago as 1838 by Dyer and Hemming, but it was first carried out practically in 1855 by Schlóssing and Rolland near Paris. Even they did not succeed in overcoming the numerous practical difficulties which surround this subject, and the credit of having brought this process to an economical issue belongs to Solway, who in 1861 established the ammonia-soda manufacture near Brussels, and by improved arrangements placed it on so satisfactory a basis that it has now been successfully introduced, and is being worked on the large scale in several countries!

Manufacture of Soda from Cryolite.—Cryolite is a double fluoride of aluminium and sodium, having the composition $\text{Al}_2\text{F}_6 + 6\text{NaF}$, and occurring in large quantities in Greenland. When this finely-divided mineral is mixed with chalk and the mixture heated the following decomposition occurs :

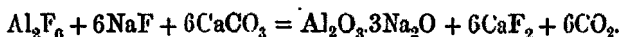

The fused mass is lixiviated, when the sodium aluminate dissolves, calcium fluoride remaining behind. Carbon dioxide is then passed through the solution when alumina is thrown down, and the liquid on evaporation yields carbonate of soda.

In conclusion, it may be stated that the native carbonate of soda or Trona, obtained from the Egyptian soda lakes, is still an article of commerce, no less than 2,500 tons of this salt being annually shipped from Alexandria.

85 Manufacture of Bicarbonate of Soda.—This salt is made by exposing crystalline masses of the decahydrated carbonate, inclosed in large chambers, to the action of carbon dioxide, generated by the action of hydrochloric acid upon limestone.

¹ Bericht d. Entwicklung chem. Indust. 1875, p 445.

The gas is slowly absorbed by the crystals, which lose their water of crystallization and with it their transparency :



Much of the impurity contained in the soda-crystals is thus removed, and accordingly sodium bicarbonate is the purest form of soda salt manufactured on the large scale. It is largely used in medicine, and in the preparation of baking-powders, and effervescing-powders and drinks.

Sodium Potassium Carbonate, NaKCO_3 . A mixture in the proportion of equal molecules of the carbonates of sodium and potassium fuses more readily than either of the separate salts. Hence this mixture is frequently used as a flux in the analysis of silicates and other minerals. When the solution of such a mixture is evaporated large monoclinic crystals separate out. These have the composition $\text{NaKCO}_3 + 10\text{H}_2\text{O}$, and possess a specific gravity of 1.62. They effloresce on exposure to air, and on recrystallization they decompose. 100 parts of water dissolve at $12^\circ 5$ 133, at 15° 185, parts of the crystallized salt.

SODIUM AND SULPHUR.

86 The compounds of sodium and sulphur are very similar to those of potassium and sulphur. Sodium monosulphide is now not unfrequently used on the large scale, as in the manufacture of soluble glass and sodium thiosulphate. It is best prepared, according to Jean, by heating in a reverberatory furnace 25 kilograms of sodium sulphate (salt-cake), 75 kilos. of barium sulphate (heavy spar), 10 kilos. of charcoal and 15 of coal-dust. The firing is continued until a solution containing barium salt is obtained. The mass is then lixiviated and the solution of barium sulphide precipitated by sodium sulphate. The clear solution is then evaporated to the crystallizing point or to dryness. The sulphate of barium can again be used, and is added for the purpose of preventing the fusion of the mass, and thus enabling the process of lixiviation to go on quickly.

SODIUM AND NITROGEN.

87 *Sodamide*, NH_2Na . This compound, discovered by Gay-Lussac and Thénard, is formed when dry ammonia is passed over fused sodium. The surface of the metal soon becomes

covered with drops of a greenish blue colour, and as these run off fresh ones are formed, until the whole of the metal is transformed into the anide. On cooling this forms a greenish or reddish crystalline mass, which when heated in a current of carbon dioxide begins to glow with formation of caustic soda and cyanamide:

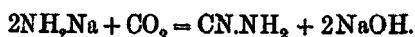

DETECTION AND ESTIMATION OF SODIUM.

88 The presence of a sodium compound can be readily detected by the production of the yellow tint which it imparts to the non-luminous gas-flame. This reaction was first observed by Melville in 1752, and was made use of by Marggraf in 1759 to distinguish the base contained in common salt from that peculiar to the vegetable alkali which imparted a violet tint to flame.

The spectrum of the yellow soda flame consists of two bright yellow lines coincident with the two dark solar lines known as Fraunhofer's D-lines. These lines have a wave-length of 5895 and 5889 ten-millionths of a millimeter, and lie so close together that in an ordinary one-prism spectroscope they appear as one line.

The spectrum-reaction of sodium is the most delicate one known. When the temperature of the flame is high and, if a large quantity of substance be present, traces of a continuous spectrum are observed in the neighbourhood of the lines; it thus may happen that the lines of other metals occurring near the sodium lines are rendered invisible until the greater part of the sodium compound has been volatilized. The most volatile sodium salts give this reaction most readily, but even those which volatilize with difficulty, such as the phosphates and silicates, can thus be detected. Such is the delicacy of this reaction that Bunsen has shown that $\frac{1}{3000000}$ of a milligram of sodium salt can thus be detected with certainty. With a reaction so delicate, it is easy to explain why the sodium reaction is always seen in ignited atmospheric air. The earth's surface is covered for more than two-thirds of its area with a solution of chloride of sodium, fine particles of which are constantly being carried by the action of the waves into the air. These particles of sea-water thus thrown into the atmosphere evaporate, leaving almost inconceivably small residues, which, floating about, are

almost always present in the air, and are rendered evident to our eyesight in the motes which dance in the sunbeam.

In order to show this universal distribution of sodium salts the following experiments may be made. A clean thin platinum wire is held in a non-luminous gas-flame for an instant; the yellow colouration due to the presence of sodium compounds is instantly seen, but this disappears in a few seconds as soon as the sodium salt on the wire has been volatilized. If now the wire free from sodium compounds be brought in contact with the slightest particle of dust, or touched by the finger, or if it be simply allowed to remain quietly in the air for half an hour, the same yellow colouration will again be observed if it be brought for a second time into the flame. The same fact is also seen when a dusty book is knocked near a non-luminous flame, the yellow colour being distinctly visible.

The absorption-spectrum of sodium vapour has been mapped by Roscoe and Schuster.¹ A series of bands in the blue make their appearance at a low temperature, and as this is raised bands in the red and yellow stretching as far as the D-lines come out. When the vapour of sodium is examined in a red-hot iron tube the colour of the limelight as seen through it is a dark blue.

In the processes of quantitative analysis sodium generally occurs together with potassium. The process for the separation of these two metals has already been described, as well as the indirect method by which the quantity of the two metals can be ascertained (see pp. 101, 102). If it is desired to determine the sodium directly, the best process is the following one suggested by Bunsen. The alcoholic solution of the soluble double chloride of sodium and platinum is evaporated in a flask which is filled with hydrogen gas and exposed to the light. Sodium chloride, hydrochloric acid and metallic platinum are then formed; the solution of common salt is filtered from the platinum, evaporated to dryness, and the weight of the salt ascertained after gentle ignition. As sodium chloride is volatile at a red heat, it is advisable to transform the salt into sulphate before ignition.

The atomic weight of sodium has been most carefully determined by Stas. He found as the mean of ten experiments that 100 parts by weight of pure silver required from 54.206 to

¹ *Proc. Roy. Soc.* xxii. 362.

54.209 parts of sodium chloride for complete precipitation. This gives a mean of 54.2075, and hence the atomic weight of sodium is 22.99.

LITHIUM, Li = 7.01.

89 Lithium was discovered in 1817 by Aug. Arfvedson, whilst he was working in Berzelius' laboratory.¹ He obtained a new alkali, and Berzelius gave to it the name *lithia*. It was first found in several minerals, from the iron mines of Utö in Sweden, especially petalite and spodumene.

Lithium is derived from *λίθος*, stony, as it was then believed to be an alkali whose presence was confined to mineral matter in contradistinction to the other alkalis which were found in vegetable and animal bodies. Since that time, however, lithium has been shown to be very generally distributed throughout the animal and vegetable kingdoms.

Metallic lithium was first prepared by Bunsen and Matthiessen in 1855.

The general distribution of small quantities of lithium compounds was first ascertained by Bunsen and Kirchhoff in their first research on spectrum analysis in 1860.²

Sources of Lithium.—The most important minerals containing this element are triphylite, a phosphate of iron, manganese, and lithium, $(\text{LiNa})_3\text{PO}_4 + (\text{FeMn})_3(\text{PO}_4)_2$, containing from 1.6 to 3.7 per cent. of lithium; petalite, a silicate of aluminium, sodium, and lithium, containing 2.7 to 3.7 per cent. of lithium; lepidolite or lithia-mica 1.3 to 5.7 per cent.; spodumene or triphane, a silicate of aluminium, sodium, and lithium 3.8 to 5.6 per cent. Smaller quantities of lithium, whose presence can be ascertained by the spectroscope, are found in a large number of minerals. The water of certain mineral springs also contains large quantities of dissolved lithium salts. Thus Berzelius³ so long ago as 1822 detected this element in the water of Egger-Franzensbad, and in 1825 in those of the springs at Karlsbad and Marienbad. The spectroscope has since shown that lithium occurs in most mineral waters, in sea-water, and in that of almost every river⁴ and surface spring. Some mineral springs contain

¹ *Schw.* xxii. 93; *Ann. Chim. Phys.* x. 82.

² *Phil. Mag.* [4] xx. 97.

³ *Pogg.* iv. 245.

⁴ *On Thames Water.* A. and F. Dupré. *Phil. Mag.* [4] xx. 373.

lithium in considerable quantity. Thus Bunsen found 295·2 mgrm. of lithium chloride in one liter of the water of the Murspring at Baden-Baden,¹ and W. A. Miller² found 372 mgrm. in one liter of water from a spring in the Wheal Clifford mine at Redruth in Cornwall.

By the decomposition of rocks containing lithium this metal finds its way into the soil. It has been detected in that of the Limagne d'Auvergne, and can be traced in the ashes of the plants which grow in that district (Truchot).³ It is widely distributed throughout the vegetable kingdom, occurring in the ash of the vine, in that of many cereals, in sea-weed and in tobacco (Bunsen and Kirchhoff). It has been found especially in the leaves of many plants, in cacao, coffee, and sugar-cane. It appears however that lithium salts cannot replace potassium salts in plants; indeed, when added in quantity they generally seem to act as a poison. In certain plants, however, such as for instance the *Samolus Valerandi*, lithium appears to act beneficially, inasmuch as the stronger plants contain most lithium.

From the vegetable world lithium finds its way into the animal kingdom; thus Bunsen and Kirchhoff observed its presence in the ashes of milk and in human blood and muscular tissue. Nor is lithium a metal which is confined to terrestrial matter, for Bunsen⁴ has detected it in two meteoric masses, one of which fell at Juvenas in France on May 15, 1821, and the other at Parnallee in Southern India on 28th February, 1857, and Engelbach⁵ observed lithium in a meteorite from the Cape. The presence of lithium has also been detected in the atmosphere of the sun (Lockyer).

90 *Extraction of Lithium Salts.*—1. From petalite and lepidolite. The first method of extraction, proposed by Berzelius,⁶ consists in fusing the powdered mineral with double its weight of lime. On dissolving the fused mass in hydrochloric acid, and evaporating with sulphuric acid, the lithium is obtained in solution as sulphate, together with some aluminium sulphate and gypsum. The first salt is precipitated by addition of chalk, and the second by oxalate of ammonia. This method was improved by Regnault and again much simplified by Troost.⁷ This latter chemist fuses the following mixture at a very high temperature

¹ *Jahresbericht der Chemie* 1861, 1091.

² *Chem. News*, x. 181.

³ *Deutsch Chem. Ges. Ber.* vii. 653; *Comptes Rendus*, lxxviii. 1022.

⁴ *Ann. Chem. Pharm.* cxx. 253.

⁵ *Pogg. Ann.* cxvi. 512.

⁶ *Traité*, ii. 89.

⁷ *Comptes Rendus*, xliii. 921

in a wind furnace: finely powdered lepidolite, 10 parts; barium carbonate, 10 parts; barium sulphate, 5 parts; potassium sulphate, 3 parts. The heavy silicate and sulphate of barium sink to the bottom, and a layer of the sulphates of potassium and lithium is found at the top of the fused mass. These can be extracted by simple lixiviation. The sulphates are then converted into chlorides by the addition of barium chloride, the chlorides evaporated to dryness, and the lithium chloride extracted by treatment with a mixture of absolute alcohol and ether.

2. For the purpose of extracting lithium salts from triphylite, a process proposed by Hugo Müller,¹ is the best. This consists in dissolving the mineral in hydrochloric acid, oxidizing with nitric acid, precipitating the phosphoric acid with a persalt of iron, evaporating to dryness and extracting with hot water. Chlorides of manganese and lithium are thus dissolved. The manganese is precipitated by sulphide of barium, and the excess of barium removed by sulphuric acid. The oxalate of lithium is obtained by evaporating with oxalic acid, and this on ignition is converted into the carbonate.

91 *Preparation of Lithium.*—The attempts made by Arfvedson and Gmelin to prepare metallic lithium were fruitless. They endeavoured to separate the metal by the electrolysis of its salts but the battery they used was not powerful enough. Later on, the decomposition of lithia was tried by heating it with iron, and carbon; these experiments also proved abortive. Then Davy succeeded in obtaining a small quantity of the metal by electrolysis, but was unable to examine its properties. In 1855 Bunsen and Matthiessen were the first to obtain lithium by electrolysis in quantity, and to examine its properties carefully. The following is Bunsen's description of the process.² "Pure chloride of lithium is fused over a Berzelius' spirit-lamp (or Bunsen's gas-lamp), in a small thick porcelain crucible, and is decomposed by a zinc-carbon battery consisting of four to six cells. The positive pole is a small splinter of gas-coke, and the negative an iron wire about the thinness of a knitting-needle. After a few seconds, a small silver-white regulus is formed under the fused chloride round the iron wire and adhering to it, which after two or three minutes attains the size of a small pea: to obtain the metal, the wire pole and the regulus are lifted out of the fused mass by a

¹ *Ann. Chem. Pharm.* lxxxv. 251.

² *Chem. Soc. Journ.* viii. 144.

small flat spoon-shaped iron spatula. The wire can then be withdrawn from the still melted metal, which is protected from ignition by the chloride of lithium with which it is coated. The metal may now be easily taken off the spatula with a pen-knife, after having been cooled under rock oil. As this operation can be repeated every three minutes, an ounce of chloride of lithium may be reduced in a very short time."

Lithium cannot be obtained by a similar process to that by which sodium and potassium are prepared by heating the carbonate with charcoal, or by heating the hydroxide with iron, as it can only be volatilized in a current of hydrogen at a white heat (Troost).

Properties.—Lithium is a solid, possessing a silver-like lustre, but tarnishes on exposure to the air. It is much less oxidizable than potassium or sodium. It is not so soft as these metals, but is softer than lead, and makes a grey streak on paper. Lithium can be pressed into wire, and can be welded at ordinary temperatures. It melts at 180° , and if the melted metal be pressed between two sheets of glass, a surface is obtained which exhibits the colour and brilliancy of polished silver. Lithium floats on petroleum, and is the lightest of all known solids; its specific gravity varying from 0.5891 to 0.5983 (Bunsen).

Heated in the air lithium ignites at a temperature above its fusing point, burning tranquilly with a bright white light. It also burns when heated in chlorine, bromine, iodine, dry carbon dioxide, or sulphur vapour. When thrown on to water it oxidizes, but does not fuse like sodium. Nitric acid acts on it so violently, that it fuses and often ignites. Concentrated sulphuric acid attacks it slowly, but diluted sulphuric and hydrochloric acids quickly. Silica, glass, and porcelain are attacked by lithium at a temperature below 200° (Bunsen and Matthiessen). Lithium is more electro-negative than sodium.

LITHIUM AND OXYGEN.

92 *Lithium Oxide, Li_2O .*—Dry oxygen does not act upon lithium at the ordinary temperature. Indeed the metal may be melted in the air without losing its brilliancy. Heated much above 180° lithium takes fire and burns brilliantly in the air with the formation of lithium oxide or lithia which is coloured yellow by a small quantity of a higher oxide. It may be prepared in a

purser state by heating nitrate of lithium in a silver basin. It forms a white crystalline mass which dissolves slowly in water with the formation of the hydrate, LiOH . This latter compound is also obtained by boiling carbonate of lithium for some hours with milk of lime, and evaporating the clear liquid to dryness in a silver basin. It forms a white caustic crystalline mass resembling caustic soda, which melts at a red-heat and does not volatilize at a white heat, and is insoluble in a mixture of alcohol and ether. Its solution absorbs carbonic acid from the air but less rapidly than soda does, and it does not deliquesce on exposure. A crystalline hydrate $\text{LiOH} + \text{H}_2\text{O}$ has also been obtained.¹

SALTS OF LITHIUM.

93 Lithium Chloride, LiCl . This salt is formed when lithium burns in chlorine, or when lithia or the carbonate is dissolved in hydrochloric acid. Its preparation from spodumene and petalite has already been described. By evaporating the aqueous solution above $15^{\circ}\cdot 5$, or the alcoholic solution over sulphuric acid, the chloride is obtained in octohedrons. The salt melts at a low red-heat to a mobile liquid. Its specific gravity is 2.074. It is one of the most deliquescent salts known, and is also very soluble in alcohol; when its aqueous solution is evaporated to dryness, traces of hydrochloric acid are given off, a little lithia being formed; and on re-dissolving, the liquid has an alkaline reaction. Two hydrated chlorides are known, viz., $\text{LiCl} + \text{H}_2\text{O}$ and $\text{LiCl} + 2\text{H}_2\text{O}$.

100 parts of water dissolve :

At	0°	20°	65°	80°	140°	160°
LiCl	63.7	80.7	104.2	115	139	145 parts

The saturated solution boils at 171° (Kremers).

Normal Lithium Sulphate, $\text{Li}_2\text{SO}_4 + \text{H}_2\text{O}$. This salt, which crystallizes in thin monoclinic plates, is obtained by dissolving the carbonate in sulphuric acid. It is easily soluble in water and alcohol.

Hydrogen Lithium Sulphate, LiHSO_4 , is also known.²

Double Sulphate of Lithium and Potassium, KLiSO_4 . Rhombic crystals of this double salt separate out when a solution containing equal molecules of the two sulphates is cooled.

¹ Muretow, *Ber. Deutsch. Chem. Ges.* v. 331.

² Schultz, *Pogg.* cxxxiii. 137.

Lithium Nitrate, LiNO_3 , a salt very soluble in both water and alcohol, is obtained by dissolving lithium carbonate in nitric acid. It crystallizes at 15° in anhydrous rhombohedrons isomorphous with sodium nitrate (Troost), whilst below 10° a hydrated salt having the composition $2\text{LiNO}_3 + 5\text{H}_2\text{O}$ is deposited.

94 *Normal Lithium Phosphate*, Li_3PO_4 , is distinguished from the phosphates of the other alkaline metals by its difficult solubility in water, in this respect resembling the phosphates of the next group of metals. It is precipitated as a crystalline powder by adding a lithium salt to common phosphate of soda together with caustic soda. It may also be obtained as a light amorphous powder by treating a lithium salt of a volatile acid with an excess of sodium phosphate. It dissolves in 2,539 parts of water and in 3,920 of water rendered alkaline by ammonia. In presence of ammoniacal salts it is much more soluble, and is precipitated from the solution by heating with caustic potash. It is readily soluble in hydrochloric and nitric acids; baryta water precipitates the phosphoric acid from the solution as barium phosphate, the whole of the lithium salt remaining in solution (W. Mayer). When a nitric acid solution of the normal salt is evaporated and the excess of free acid driven off, the di-hydrogen salt, H_2LiPO_4 , remains behind. This is readily soluble, and, on evaporation over sulphuric acid, deposits deliquescent crystals.

Lithium Orthosilicate, Li_2SiO_4 , is prepared by fusing lithium carbonate with silica. This reaction differs from that observed with an excess of the other alkaline carbonates, inasmuch as in this case two molecules of carbon dioxide are liberated for every molecule of silica employed. The salt is decomposed by water (Yorke).

95 *Normal Lithium Carbonate*, Li_2CO_3 . This salt, unlike the carbonates of the other alkali metals, is but slightly soluble in water, thus more nearly resembling the carbonates of the next group of metals. It is precipitated as a crystalline powder when concentrated solution of lithium chloride is poured into a solution of ammonium carbonate in aqueous ammonia, and the mixture heated so long as the precipitate increases in bulk. 100 parts of water at 13° dissolve 0.769 parts of this salt, and at 102° , 778 parts (Kremers). If the solution be slowly evaporated, crystalline crusts or small transparent crystals of the salt are deposited. If these be suspended in water, and carbon dioxide passed in 5.25 parts of the salt dissolved in 100 parts of

water, hydrogen lithium carbonate, HLiCO_3 , is formed. This solution on standing or evaporation loses carbon dioxide, and the normal salt is again deposited. Carbonate of lithium is employed in medicine, especially in gouty affections.

DETECTION AND ESTIMATION OF LITHIUM.

96 The presence of extremely small traces of lithium compounds ($\frac{1}{10,000,000}$ of a milligram) can be ascertained with certainty by means of the spectroscope. The luminous vapour of lithium, obtained by bringing a trace of the salt on a fine platinum wire into the non-luminous gas flame, gives, when examined by a spectroscope, two sharply defined lines—the one a very weak yellow line, $\text{Li}\beta$ (wave-length = 6101); the other a bright red line $\text{Li}\alpha$ (wave-length = 6708). Not only do all the lithium salts when thus heated give this reaction but ashes of plants, and the lithium minerals only require for this purpose to be held in the flame. Natural silicates which only contain traces of lithium must first be subjected to the following treatment. A small portion of the substance is digested with hydrofluoric acid, the residue moistened with sulphuric acid and heated; the dry mass is then treated with alcohol and the extract allowed to evaporate in a shallow dish. The solid particles are scraped off and brought into the flame on the platinum wire (Bunsen).

Lithium is separated from all the heavy and earthy metals in the ordinary process of analysis. It may be separated from potassium by the precipitation of the latter metal as the insoluble double chloride of potassium and platinum, the corresponding lithium compound being soluble. It can be separated from sodium by the solubility of lithium chloride in a mixture of ether and absolute alcohol. But as by this process a small quantity of sodium chloride is found to dissolve, Bunsen¹ recommends an indirect method by determining the quantity of silver chloride yielded by a given weight of the mixed alkaline chlorides.

The atomic weight of lithium was ascertained by K. Diehl by estimating the amount of carbon dioxide contained in the pure carbonate. It was afterwards determined by Stas by converting the chloride into the nitrate, and by the determination of the amount of chlorine contained in lithium chloride.

¹ *Phil. Mag.* [4] xxiv, 48.

RUBIDIUM, Rb = 85².

97 In the year 1860 Bunsen¹ announced the discovery by means of spectrum analysis of a new alkali-metal, to which he gave the name of *Cæsium*, and in 1861 he discovered by the same method a second new alkali metal, and to this he gave the name *Rubidium*.

These two metals and their compounds possess so close a resemblance, and at the same time give reactions so similar to those of potassium, that they cannot be distinguished either from the well-known alkali or from one another by any of the common wet reactions or blowpipe tests. The only means by which their presence can be detected is by their spectrum reactions, and these are so delicate and so characteristic that they serve for the certain recognition of the minutest trace of these two new bodies, whether present alone or mixed with the other alkalis. The metals were first met with by Bunsen in the waters of Dürkheim in the Palatinate, and in the mineral petalite. In these, however, they are contained in such small quantity that, although their presence can be easily recognized in a few drops of the water or in a few grains of the mineral, it was requisite to boil down 40 tons of the water and to work up 150 kilograms of the mineral in order to obtain enough of the new metals to serve for the investigation of their compounds.

The following extract from Bunsen and Kirchhoff's second memoir on Spectrum Analysis² gives a clear idea of the method by which the presence of the two new metals was first detected:—

“If a drop of the mother-liquor of the Dürkheim water be brought into the flame of the spectrum apparatus, the characteristic lines of sodium, potassium, lithium, calcium, and strontium are at once seen. If the lime, strontia, and magnesia be separated according to well-known processes, and if the residual alkali bases in the form of nitrates be washed out with alcohol, and the lithium removed as completely as possible by precipitation with carbonate of ammonium, a mother-liquor is obtained which in the spectrum apparatus shows the lines of sodium, potassium, and lithium, but besides these, two splendid

¹ *Berlin Acad. Ber.* May 10, 1860.

² *Phil. Mag.* [4] xxii. 330.

blue lines situated close together, and almost coinciding with the blue strontium line $Sr\delta$.

"As no known elementary body produces two blue lines in this portion of the spectrum, we may consider the existence of this hitherto unknown alkaline element as thus placed beyond doubt.

"The facility with which a few thousandths of a milligram of this body may be recognized by the bright blue light of its incandescent vapour, even when mixed with large quantities of more common alkalis, has induced us to propose for it the name *Cæsium* (and the symbol Cs), derived from the Latin *cæsius*, used to designate the blue of the clear sky.¹

"If Saxony lepidolite be treated by any of the known plans for separating the alkalis from the other constituents, and if the solution of the alkalis thus obtained be precipitated with dichloride of platinum, an abundant precipitate is formed, which, when examined in the spectrum apparatus, shows only the bright potassium lines. If this precipitate be repeatedly washed with boiling water, and the residual salt occasionally examined in the apparatus, two splendid violet lines lying between the strontium line $Sr\delta$ and the blue potassium line $K\beta$ will be noticed on the gradually fading continuous background of the potassium spectrum. These new lines increase in brilliancy as the washing is continued, and a number more appear in the red, yellow, and green portions of the spectrum.

"None of these lines belong to any previously known body. Amongst them are two which are especially remarkable as lying beyond Fraunhofer's line A and the potassium line $K\alpha$ coincident with it, and therefore situated in the outermost portion of the red solar rays. Hence we propose for this new metal the name *Rubidium* (and the symbol Rb), from the Latin *rubidus*, which was used to express the darkest red colour.²

Since this discovery, rubidium has been shown to be widely distributed, generally accompanying the other alkalis, but in very minute quantities. Rubidium occurs in many minerals, such as lepidolites, and triphyllines, in Stassfurt carnallite, in Vesuvian leucite, in the porphyrites of the Palatinate, in mica and in orthoclase.

¹ Anlus Gellius, in his *Noctes Atticæ*, ii. 26, quotes Nigidius Figulus as follows: "Nostris autem veteribus cæsia dicta est, quæ a Græcis γλασκώνις ut Nigidius ait, de colore caeli quasi coelia."

² Anlus Gellius, *Noctes Atticæ*, ii. 26. "Rubidius autem est rufus atrior et nigrore multo inusius."

The following is the analysis of the lepidolite from Rozena in Moravia in which Kirchhoff and Bunsen first discovered rubidium:—

Silica	50.32
Alumina	28.54
Ferric oxide	0.73
Lime	1.01
Magnesia	0.51
Rubidium oxide	0.24
Cæsium oxide	trace
Lithium oxide	0.70
Lithium fluoride	0.99
Sodium fluoride	1.77
Potassium fluoride	12.06
Water	3.12
	99.99

A large number of brine-springs and mineral-waters also contain the new alkali. Thus the hot springs of the Ungernach contain in 1 liter 1.3 milligram of chloride of rubidium (Bunsen); the mineral water of Bourbonne-les-Bains contains 18.7 milligrams of the same salt, and 32.5 milligrams of cæsium chloride.

The celebrated waters of Ems, Kissingen, Naubem Selters, Vichy, Wildbad-Gastein, and many others contain rubidium, and some of them also cæsium compounds. Rubidium has been found in sea-weed and in sea-water (Sonstadt),¹ and also in the mother-liquors (bitterns) from the salterns of Villefranche (Grandeau). Rubidium salts are also widely met with in the vegetable kingdom. Beetroot takes up these salts from the soil, and in the saline residue obtained by calcining the fermented molasses considerable quantities of rubidium salts are contained. Thus 100 parts of the saline residue contain 0.18 parts of chloride of rubidium (Grandeau). Then it has also been found in samples of tobacco grown in the most distant quarters of the globe—such as Algiers, Havana, Kentucky, France, and Macedonia. Rubidium likewise occurs in several kinds of coffee and tea (Grandeau); in the ash of the oak, *Quercus Pubescens*, in those of beech trees grown on a basaltic soil, in crude cream

¹ *Chem. News*, xxii.

of tartar, and in potashes from various sources. Plants can however not absorb rubidium salts in place of potassium salts and they die if these latter are not present (Lucanus).

Mode of preparation of Rubidium compounds.—According to Bunsen the best source of rubidium is the saline residue left from the preparation of lithium salts from Saxon lepidolite. This consists of the chlorides of sodium, potassium, and lithium, and traces of the chlorides of caesium and rubidium. The separation of these new metals is based upon the fact that their chlorides form double chlorides with platinic chloride, which are more insoluble than the corresponding potassium double chloride.

One kilogram of the saline mixture is dissolved in 2.5 kilograms of water, and the cold liquid precipitated by a solution of thirty grams of platinum in aqua regia. The precipitate, having settled down, is collected and boiled twenty-five times successively with small quantities of water, in all about 1.5 kilograms, the liquid in each case being poured on to the solution of the original salt. A fresh precipitate is then formed, this is again washed and treated as the first, and when the above series of operations have been repeated seven or eight times the rubidium will be nearly all extracted. Each of the platinum precipitates is then dried, the platinum reduced by hydrogen, and the alkaline chlorides dissolved in water. In this way 125 grams of rubidium chloride were obtained, containing three or four per cent. of chloride of potassium, and a little chloride of caesium. By a repetition of the precipitation and washing of the platinic double chloride this quantity of potassium impurity can be so completely removed that the well-known red potassium line (K_{α}) is not seen with a spectroscope when some of the salt is held in the flame (Bunsen).

98 *Preparation of the Metal.*—Rubidium is prepared by the same process as that used for potassium.

Charred tartrate of rubidium is heated in an iron tube to whiteness. Bunsen prepared the metal first, and he obtained five grams of rubidium from seventy-five grams of the tartrate.

It is a silver white metal of specific gravity 1.52. At -10° it is still soft and wax-like. It melts at $38^{\circ}.5$, and emits at incipient redness a blue coloured vapour. It appears to form an explosive compound with carbon monoxide as potassium does.

Rubidium Oxide and Hydrate, Rb_2O and $RbOH$. Rubidium on exposure to air at once becomes covered with a bluish

coating of suboxide, and takes fire spontaneously more readily than potassium with formation of the white oxide, Rb_2O (Bunsen).

When thrown on to water rubidium burns like potassium. The hydrate is best prepared by adding baryta-water to a solution of rubidium sulphate. A greyish white, deliquescent mass is obtained by evaporating the clear solution to dryness in a silver vessel.

SALTS OF RUBIDIUM.

These salts present the greatest similarity to those of potassium and are isomorphous with them.

Rubidium Chloride, RbCl . Rubidium takes fire in chlorine gas burning with a bright light. Chloride of rubidium crystallizes in glittering cubes which melt at a red-heat. 100 parts of water dissolve at 1° 76.38, and at 7° 82.89 parts of the salt.

Rubidium Chlorate, RbClO_3 , is obtained by the double decomposition of rubidium sulphate and barium chlorate. It crystallises in small prisms which taste like potassium chlorate, and of which 2.8 parts dissolve in 100 parts of water at 4° 7 and 5.1 parts at 19° .

Rubidium Perchlorate, RbClO_4 , is a granular powder consisting of glittering microscopic crystals belonging to the rhombic system. When heated below redness it decomposes into rubidium chloride and oxygen. 100 parts of water dissolve at 21° 3 1.085 parts of the salt.

Normal Rubidium Sulphate, Rb_2SO_4 , exists as large rhombic crystals which taste like potassium sulphate. 100 parts of water dissolve at 10° 42.4 parts of this salt.

Rubidium Nitrate, RbNO_3 , crystallizes in needles or prisms, and is very soluble in water; 100 parts of water dissolve at 0° 20.1, and at 10° 43.5 parts of this salt. It can be distinguished from nitre, inasmuch as it readily dissolves in concentrated nitric acid.

Rubidium Carbonate, Rb_2CO_3 . The normal salt is obtained by decomposing the sulphate with baryta water and evaporating the filtrate with carbonate of ammonia. It is a deliquescent powder which is very soluble in water. If the solution of this salt be saturated with carbon dioxide, and allowed to evaporate

over sulphuric acid, glittering prisms of the acid salt, HRbCO_3 , are obtained; these have a cooling taste and are easily soluble in water.

DETECTION AND ESTIMATION OF RUBIDIUM.

99 The rubidium salts when brought into the non-luminous gas flame impart to it a tint rather more of a red shade than is produced by the potassium salts.

The flame spectrum exhibits two characteristic lines in the violet $\text{Rb}\alpha$ (wave-length 4202) and $\text{Rb}\beta$. These are the most valuable as the means of recognising the rubidium salts. Two other rubidium lines, $\text{Rb}\delta$ and $\text{Rb}\gamma$, are seen at the red end of the spectrum; they are both less refrangible than the red potassium lines. Besides these several other characteristic lines occur. The spectrum reaction for rubidium is so delicate that 0.002 mgrm. can be readily detected (Bunsen).

Bunsen determined the atomic weight of the metal by precipitating the pure chloride by nitrate of silver. He found as a mean result the number 85.2 for the atomic weight of rubidium, and Grandeau obtained a closely corresponding number by the analysis of the sulphate.

CÆSIUM, Cs = 132.5.

100 This metal is remarkable not only as having been the first one discovered by spectrum analysis, but also because even before Bunsen's discovery of this metal, chemists had investigated certain cesium compounds, which however they had mistaken for potassium salts. Thus, in the year 1846, Plattner analyzed a rare mineral found in the island of Elba, and termed Pollux,¹ with the following result:—

Silica	46.20
Alumina	16.39
Ferric oxide	0.86
Potash	16.51
Soda	10.47
Water	2.32
	92.75

¹ *Pogg. Ann.* lxi. 443.

Plattner, being a careful experimentalist, sought for an explanation of the fact that his analyses did not add up to 100 parts, although he searched in vain for all other constituents. The explanation of the enigma was given by the discovery of caesium, for Pisani¹ in the year 1864, found on analysis of another sample of the same mineral that the alkali which Plattner had mistaken for potassium is, in reality, caesium. His analysis gave the following numbers:—

Silica	44.03
Alumina	15.97
Ferric oxide	0.68
Lime	0.68
Caesia	34.07
Soda	3.88
Water	2.40
	101.71
	101.71

If we now calculate the quantity of caesium oxide corresponding to the amount of potash found by Plattner as the platinum double salt, we obtain the number 35.69; if we next subtract the weight of the chloride of caesium thus found from the weight of the mixed chlorides of caesium and sodium as found by Plattner, we obtain the number 1.72 as the amount of soda present. These numbers correspond satisfactorily with Pisani's results, especially when we remember that the quantity of mineral analysed by Plattner was very small. Both analyses, therefore, lead to the formula for pollux of—

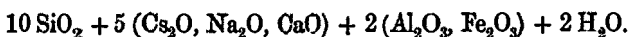

It has already been mentioned under rubidium that caesium occurs generally together with this and the other alkali metals. Caesium alone is found in the mineral waters of Frankhausen, of Monte Latino in Tuscany, as well as in the Wheal Clifford Spring, one liter of this latter water containing 1.71 mgrms. of caesium chloride (Yorke). It is a remarkable fact that plants do not take up any caesium compounds from the soil, and in absence of potassium compounds, caesium acts as a poison upon vegetable life (Lucanus).

Metallic caesium has not yet been obtained in the pure state.

¹ *Comptes Rendus*, lx. 714.

When an electric current is passed through melted caesium chloride, small globules of metal are formed at the negative pole, and these rise to the surface and burn with a brilliant flame. In the presence of mercury an amalgam is formed which is more electro-positive than the rubidium amalgam, and hence metallic caesium is the most electro-positive of the metals.

Caesium Hydroxide, CsOH , is obtained by a process similar to that by which rubidium hydroxide is prepared, and resembles it in every particular.

SALTS OF CÆSIUM.

101 The caesium salts are isomorphous with those of potassium and rubidium. They colour the flame of a still more reddish tint than the salts of the last named metal. The caesium platinum double chloride, Cs_2PtCl_6 , is still more insoluble than the corresponding rubidium compound.

Caesium Chloride, CsCl , crystallizes in small cubes which melt at a dull red heat, and volatilize even more readily than potassium chloride. It is very hygroscopic and deliquesces in moist air.

Normal Caesium Sulphate, Cs_2SO_4 , forms short, hard, prismatic crystals, insoluble in alcohol though readily soluble in water. The acid salt, HCsSO_4 , crystallizes in rhombic prisms.

Caesium Nitrate, CsNO_3 , crystallizes in small glittering prisms which possess the cooling taste of saltpetre, and are slightly soluble in alcohol. 100 parts of water at $3^{\circ}2$ dissolve 10.58 parts of this salt.

Normal Caesium Carbonate, Cs_2CO_3 . This salt separates out from a syrupy solution in the form of ill-defined hydrated deliquescent crystals. They melt on heating, leaving a residue of the anhydrous salt as a sandy powder. It is soluble in absolute alcohol. 100 parts of alcohol dissolve at $19^{\circ}11.1$, and at the boiling point 20.1 parts of the anhydrous salt. The acid salt, HCsCO_3 , crystallizes from aqueous solution in large prisms.

DETECTION AND ESTIMATION OF CÆSIUM.

102 The spectrum of caesium contains in addition to the two characteristic bright blue lines Csa (wave-length 4972) and $\text{Cs}\beta$, several other less distinct lines.

In order to separate caesium from rubidium salts, the solubility of the normal carbonate of caesium in absolute alcohol may be made use of (Bunsen). A second method of separation depends upon the fact that the acid tartrate of rubidium, $C_4H_5RbO_6$, is much more insoluble than the corresponding caesium compound. For this separation twice as much tartaric acid is added to the solution of the mixed carbonates as is needed for their complete neutralization; the solution is then evaporated at 100° until it is nearly saturated and allowed to cool. Acid tartrate of rubidium then separates out, and after having been three times recrystallized it is free from caesium.¹

Another very useful method of separation depends upon the fact that caesium alum, $Cs_2SO_4 \cdot Al_2(SO_4)_3 + 24H_2O$, is much less soluble than the corresponding rubidium and potassium alums. 100 parts of water at 17° dissolve 0.619 parts of caesium alum, 2.27 parts of rubidium alum, and 13.5 parts of potassium alum (Redtenbacher). By frequent recrystallization of the mixed alums, the rubidium and caesium can be readily separated from one another. In order to prepare the pure salts it is only necessary to precipitate the alumina by means of ammonia, and to ignite when the sulphates are left, from which the other compounds can be readily obtained.²

A third method of separation depends upon the formation of an insoluble double chloride which caesium forms with stannic chloride, $CsSnCl_6$.³ Instead of stannic chloride, antimony chloride may also be used, which is dissolved by concentrated hydrochloric acid, and mixed with an acid solution of the mixed alkaline chlorides. A white precipitate then falls possessing the composition $SbCl_5 + 6CsCl$.⁴ The tin or antimony can be readily separated from either of these compounds by sulphuretted hydrogen, and on evaporating the solution, pure caesium chloride remains behind.

As an illustration of the method by which the relative quantities of rubidium and caesium can be determined in a mixture of the chlorides of the two metals, the following determination by Bunsen may be quoted. The mixed chlorides weighing 1.0348 gm. were precipitated by silver nitrate, and thus 1.1404 gm. of silver chloride obtained. Let A signify

¹ Allen, *Sill. Am. Journ.* [2], xxxiv. 367.

² Godeffroy, *Liebig Ann.*, clxxx. 176.

³ Sharples, *Sill. Am. Journ.* [2], xlvii. 178.

⁴ Godeffroy, *Ber. Deut. ch. Chem. Ges.* viii. 9.

the weight of x parts of chloride of rubidium and y parts of chloride of caesium, and let B signify the weight of silver nitrate. Then we obtained the following equations—

$$x = 3.50963B - 3.16906A$$

$$y = 4.16906A - 3.50963B$$

Hence the mixture contains

$$x = 69.87$$

$$y = 30.13$$

$$100.00$$

The atomic weight of caesium has been ascertained by the analysis of the chloride by means of silver nitrate. Johnson and Allen as well as Bunsen thus obtained the number 132.7, whilst Godeffroy obtained the number 132.3.

AMMONIUM SALTS.

103 The name *volatile alkali* was long ago given to ammonia as pointing out its similarity to the fixed alkalis potash and soda. In 1808, Seebeck made the interesting discovery that when mercury is brought into a strong aqueous solution of ammonia, and an electric current is passed through it, the metal increases rapidly in bulk, giving rise to an amalgam-like mass. The same observation was made almost simultaneously by Berzelius and Pontin, whilst Davy, as soon as he was informed of the fact, repeated the experiment and discovered that a piece of sal-ammoniac moistened with water might be employed instead of aqueous ammonia. Davy also noticed that the same amalgam-like mass is formed when an amalgam of potassium is thrown into a concentrated solution of sal-ammoniac. Hence he, like Berzelius, came to the conclusion that ammonia must contain oxygen, and that in this experiment, it, like potash and soda, had been reduced by the electricity to a metal-like body. To this metal-like substance, which was supposed to exist in this amalgam, they gave the name of *ammonium*. This view of the constitution of the ammonium compounds was objected to by Gay-Lussac and Thénard, who, from their experiments on the subject, carried out in the year 1809, concluded that the formation of the amalgam is due to a combination of the ammonia

with hydrogen. They arrived at this result from observing that the amalgam undergoes rapid spontaneous decomposition into mercury, ammonia, and hydrogen gas. Arguing from analogy the French philosophers were inclined to believe that in like manner potassium and sodium could not be considered to be true metals, but were rather the hydrogen compounds of the alkalis. In reply to these objections, Davy and Berzelius showed that the hydrogen which was evolved arose from the decomposing action of the metallic ammonium upon the water which adhered to it, in the same way as when sodium and potassium are thrown into water, hydrogen is evolved. Berzelius continued for many years to hold the view that oxygen is contained in ammonia, and he explained the fact that this element could not be detected in the ammonia, by assuming that nitrogen itself is an oxide of an element hitherto not isolated, to which he gave the name of *nitricum*.

Ampère was the first, in the year 1816, to endeavour to explain the analogy of the ammoniacal salts with those of the fixed alkalis. He showed that the differences in composition between the salts of a fixed and those of the volatile alkali disappear when we assume that, in the latter class of salts, a compound radical exists composed of one volume of nitrogen to four volumes of hydrogen; so that sal-ammoniac or hydrochloride of ammonia may be regarded as the chloride of a metal-like substance to which the name of ammonium had been given. In 1820, Berzelius gave up his old view and accepted the ammonium theory. He allowed that aqueous ammonia must be regarded as a solution of ammonium oxide, and assumed that when anhydrous ammonia unites with an hydrogen acid (a substance to which we now give the simple name of acid) the ammonia combines with the hydrogen of the acid to form the metal-like radical ammonium, and that this becomes an oxide by union with the oxygen of the water.

According to our present views the ammonium salts are considered as being derived from acids by the replacement of their hydrogen by the radical ammonium. These salts are isomorphous with the salts of potassium, and otherwise exhibit a close analogy with them, as also with those of rubidium and caesium.

Ammonium Amalgam. This substance, whose existence has already been mentioned, is formed when a piece of moistened sal-ammoniac is laid on a platinum basin, a small quantity of

mercury poured upon it, and this brought in contact with the negative pole of a galvanic battery, the positive pole being connected with the platinum basin. It may be obtained, still more readily, by throwing sodium amalgam containing 1 per cent. of sodium into a concentrated solution of sal-ammoniac. The mercury increases in bulk to upwards of twenty times its original volume. It then contains from 0.6 to 0.9 per cent. of its weight of ammonium. This amalgam forms a light, soft, buttery mass which at low temperatures becomes crystalline and decomposes, even at -29° , with evolution of two volumes of ammonia and one volume of hydrogen. It may be distinguished from the amalgams of the alkali metals inasmuch as it does not reduce the salts of silver and copper.¹ Hence some chemists have supposed that it must be regarded merely as a solution of ammonia and hydrogen in mercury. Against this view, however, it is to be remembered that neither of these gases, either alone or when mixed together, dissolves at all in mercury.

104 *Ammonium Chloride*, NH_4Cl . The history of this salt, well known under the name of sal-ammoniac, has already been given at page 378 of Vol. I. It is found in the fumeroles of Vesuvius, Etna, Hecla, and other volcanoes, as well as in the cracks and fissures in recent lava streams. Its formation has also been observed when large masses of coal undergo combustion, as when a coal pit is on fire. The salt has also been observed in guano from the Chincha Islands.

Sal-ammoniac originally served as the source from which all the ammoniacal salts were prepared. At present, however, they are usually obtained from ammonium sulphate, and from the ammoniacal liquor of the gasworks both of which are prepared on an enormous scale. The manufacture of sal-ammoniac is simple enough. For this purpose the ammoniacal gas-liquor is heated with lime, and the gaseous ammonia which is thus evolved led into dilute hydrochloric acid until it is saturated. The solution is evaporated and the sal-ammoniac purified by recrystallization from hot water. The best means of purifying the sal-ammoniac is, however, by the process of sublimation, and in general sal-ammoniac occurs in commerce in the sublimed form. The vessel employed for this purpose consists of two parts. The lower one is either a semi-circular earthenware vessel embedded in an iron one, or consists entirely of a cast-iron basin. The sal-

¹ Landolt, *Ann. Chem. Pharm. Suppl. Band.* vi. 342.

ammoniac in the solid state is brought into this, and then a semi-circular dome-like cover, either of earthenware, lead, or iron, is placed over it, and this is luted tight with clay. In the centre of the dome there is an opening which is left open during the sublimation. Pure sal-ammoniac is also obtained by employing the same apparatus, but, instead of the impure salt, a mixture of common salt, NaCl, and ammonium sulphate, $(\text{NH}_4)_2\text{SO}_4$, is heated, when sodium sulphate remains behind, sal-ammoniac subliming as before.

Pure ammonium chloride is colourless and odourless and has a sharp saline taste. It crystallizes from a saturated solution in arborescent or feather-like growths which consist of an aggregation of small regular octobedrons, and other forms of the regular system, as well as combinations of these, and often exhibit trapezohedric hemihedry, so that the crystals appear to belong to the

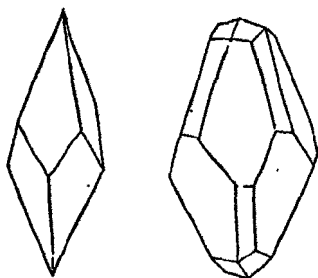

FIG. 38.

hexagonal or quadratic system (Fig. 38). From solution in urea sal-ammoniac crystallizes in cubes. When the salt is sublimed, and the vapour quickly cooled, it is precipitated in the form of a light crystalline powder known as flowers of sal-ammoniac. The common sublimed sal-ammoniac is a semi-transparent, fibrous, crystalline mass, which is so tough that it is difficult to powder the

substance. For the purpose of obtaining it in a fine powder, a concentrated solution is evaporated down, and constantly stirred.

When sal-ammoniac dissolves in water a considerable reduction of temperature takes place; 30 parts of salt dissolve in 300 parts of water at 13.3° and the temperature is reduced to -5.1 (Rudorff). 100 parts of water dissolve at $0^\circ 28.4$, at $10^\circ 32.8$, and at $100^\circ 77.2$ parts of the salt.¹ The boiling point of the saturated solution is 115° . Sal-ammoniac is somewhat less soluble in alcohol; thus 100 parts of alcohol of specific gravity 0.939 dissolve at $8^\circ 12.6$, and at $56^\circ 30.1$ parts of the salt.² The specific gravity of sal-ammoniac is 1.52. It is not volatile at the ordinary temperature of the air, but when boiled with

¹ Alluard, *Ann. Chem. Pharm.* cxxxiii. 292.

² Gerardin, *Ann. Chim. Phys.* [4], v. 129.

water ammonia escapes in small quantity, and the solution, which was perfectly neutral, becomes slightly acid. At higher temperatures it evaporates completely, giving rise to a colourless vapour, which, according to Bineau, has the specific gravity 0.89, corresponding to a vapour density of 13.345, whilst the molecular formula, NH_4Cl , requires a density of 26.69. From the fact of the abnormal density it has been argued that the sal-ammoniac vapour consists of a mixture of equal molecules of ammonia and hydrochloric acid. The truth of this supposition was first experimentally demonstrated by Pebal,¹ who allowed the vapour of sal-ammoniac to diffuse into an atmosphere of hydrogen, when the lighter ammonia was found to diffuse out and the heavier hydrochloric acid to remain behind. K. von Thian² then showed that if dry ammonia and dry hydrochloric acid be brought together at a temperature of upwards of 350° , at which point sal-ammoniac is gaseous, no change either of temperature or of the volume of the gases is observed, whereas if chemical union had taken place a change of both these would naturally have been expected. Lastly, Marignac³ observed that in the volatilization of sal-ammoniac nearly the same amount of heat is absorbed as is evolved when ammonia and hydrochloric acid combine. This fact of the dissociation of sal-ammoniac can be readily shown by igniting a small piece of the solid in a closed platinum crucible. On removing the lid after the salt has been volatilized, and plunging a moistened piece of blue litmus paper into the crucible, the litmus paper will be turned bright red, proving the presence of free hydrochloric acid, the ammonia having escaped. Deville,⁴ on the other hand, does not admit that sal-ammoniac is decomposed, as its vapour density at 1000° remains constant, a temperature at which ammonia itself is converted into its elements.

Sal-ammoniac is used in medicine. In former days that which came from Egypt was especially esteemed as a drug. Large quantities are used in the processes of dyeing, and workers in metal employ it in the processes of soldering and tinning, as at a high temperature it either reduces the metallic oxide or converts it into fusible chloride and thus gives rise to a bright metallic surface. It is also of value in the laboratory both as a reagent and as a convenient source of ammonia.

¹ *Ann. Chem. Pharm.* cxxiii. 199.

² *Comptes Rendus*, lxxviii. 877.

³ *Ann. Chem. Pharm.* cxxxi. 129.

⁴ *Jahresb.* 1863, 37.

105 *Ammonium Bromide*, NH_4Br ; is very soluble in water, and crystallizes in white cubes which taste like sal-ammoniac.

Ammonium Iodide, NH_4I , is best obtained by saturating ammonia with hydriodic acid. It crystallizes in colourless cubes readily soluble in water and in alcohol. It deliquesces in moist air and gradually assumes a yellow colour due to the slow liberation of iodine. It is used in photography as it is soluble in alcohol.

When a small quantity of iodine is gradually added to a concentrated solution of ammonium nitrate, rendered alkaline by potash, ammonium di-iodide, NH_4I_2 , separates out as a brownish black mobile liquid. This substance is soluble in alcohol and carbon disulphide. Water decomposes it into iodide of nitrogen, NHI_2 , ammonium iodide, and hydriodic acid:

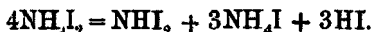

Ammonium Fluoride, NH_4F , is obtained by saturating hydrofluoric acid with ammonia. The commercial hydrofluoric acid, however, generally contains lead and other metals which must be previously removed by the addition of a small quantity of ammonium carbonate and sulphide. The clear acid liquid is then evaporated in a platinum basin and saturated with solid carbonate of ammonia. Ammonium fluoride crystallizes in hexagonal tables or prisms. It has a sharp saline taste and deliquesces in moist air. It is more easily soluble in water than sal-ammoniac, and decomposes at the ordinary temperature when in the moist state. It decomposes the silicates on being heated with them with evolution of silicon tetrafluoride, and hence it is largely used in mineral analysis and for etching upon glass. This may be readily accomplished by allowing a solution of the salt to dry upon the place which it is desired to etch. It cannot be preserved in glass bottles but must be kept in vessels either of platinum, silver, or gutta-percha.

Hydrogen Ammonium Fluoride, NH_4F , HF , is formed when a solution of the normal salt is evaporated at a temperature of about 40° . It crystallizes in colourless rhombic prisms which deliquesce slightly in the air and on heating evolve highly irritating and acrid fumes.

Ammonium Chlorate, NH_4ClO_3 . When ammonia is saturated with chloric acid and the solution evaporated, this salt crystallizes out in small needles which have a strongly acrid taste and are very soluble in water and slightly soluble in absolute

alcohol. Heated to 102° the salt decomposes (Wächter) chlorine, oxygen, nitrous oxide and aqueous vapour being evolved and sal-ammoniac remaining behind. Occasionally the salt undergoes spontaneous decomposition. When thrown on to a hot plate it decrepitates like ammonium nitrate.

Ammonium Perchlorate, NH_4ClO_4 , is obtained by saturating ammonia with perchloric acid. It forms rhombic crystals which are isomorphous with potassium perchlorate and dissolve in five parts of cold water.

106 *Normal Ammonium Sulphate*, $(\text{NH}_4)_2\text{SO}_4$. We find this salt mentioned by Libavius, but more accurately described by Glauber, who recommended its use as a medicine. It was long known by the name of *sal ammoniacum secretum Glauberi*. This salt is found in certain volcanic districts, especially in the neighbourhood of the boric acid fumeroles of Tuscany, and it is termed by mineralogists mascagnite. Ammonium sulphate is prepared on the large scale by heating the ammoniacal gas liquor with lime and leading the ammonia which is evolved into dilute sulphuric acid. The solution is then evaporated to crystallization. Large transparent crystals belonging to the rhombic system are deposited which are isomorphous with potassium sulphate. Their specific gravity is 1.77. They possess a strong saline taste and dissolve at 0° in 71, at 20° in 76.3 and at 100° in 97.5 parts of water. The salt is very difficultly soluble in aqueous alcohol and does not dissolve in absolute alcohol. Ammonium sulphate is used for the manufacture of other ammonia salts and is also largely employed as a fertiliser in artificial manures.

Ammonium Nitrate, NH_4NO_3 . This salt was first prepared by Glauber and was originally known by the name of *nitrum flammans*. It crystallizes, when its solution is slowly evaporated, in rhombic prisms, but on boiling down it is usually obtained in a fibrous mass. Its specific gravity is 1.7. It possesses a strongly saline taste, and dissolves at the ordinary temperature in half its weight of cold water, whilst it is still more soluble in hot water. In dissolving a considerable reduction of temperature takes place. Thus if 60 parts of the salt be dissolved in 100 parts of water at a temperature of $13^{\circ}6$ the temperature of the liquid sinks to $-13^{\circ}6$, whilst if water at 0° be taken the temperature of $-16^{\circ}7$ is obtained, this being the freezing point of the solution (Guthrie). It is also easily soluble in alcohol. When the dry salt is thrown on a red-hot plate it decomposes

with the evolution of a yellow flame and a slight explosion, into nitrogen, water, and nitric oxide, whereas if it be gently heated it decomposes into water and nitrous oxide, a small portion of the salt subliming unchanged.

Ammonium Nitrite, NH_4NO_2 . Berzelius describes the best means of preparing this salt to be to add a solution of sal ammoniac to silver nitrite solution. The clear solution is then evaporated over sulphuric acid. An indistinctly crystalline mass is obtained, but this, as well as its aqueous solution, decomposes when heated, into water and nitrogen.

107 *Normal Ammonium Phosphate*, $(\text{NH}_4)_3\text{PO}_4$, is obtained as a crystalline semi-solid mass when hydrogen di-ammonium phosphate is supersaturated with concentrated aqueous ammonia. It crystallizes from its solution in dilute ammonia in short prismatic needles. These contain three molecules of water of crystallization and are moderately stable in the air, but on boiling the aqueous solution two-thirds of the ammonia is evolved.

Hydrogen Di-ammonium Phosphate, $\text{H}(\text{NH}_4)_2\text{PO}_4$, occurs in guano from Ichaboe (Herapath) and is easily formed when a solution of phosphoric acid containing an excess of ammonia is allowed to evaporate; transparent monoclinic prisms are thus deposited.

Di-hydrogen Ammonium Phosphate, $\text{H}_2(\text{NH}_4)\text{PO}_4$, is formed when aqueous phosphoric acid is added to ammonia until the solution reddens litmus paper, and is no longer precipitated by barium chloride. It crystallizes in tetragonal prisms and is isomorphous with the corresponding potassium salt.

Hydrogen Ammonium Sodium Phosphate or Microcosmic Salt, $\text{HNaNH}_4\text{PO}_4 + 4\text{H}_2\text{O}$. The old alchemists were aware that this peculiar salt can be obtained from urine, but Marggraf was the first to examine with care the salt which crystallizes from evaporated urine and to show that it contains a volatile alkali, whilst Proust found in 1775 that sodium was contained in this compound. The salt was first termed *sal urinæ fixum* in contradistinction to the *sal urinæ volatile* or ammonium carbonate, but it was also termed *sal microcosmicum*, being obtained from the human body. This compound is also found in guano (Herapath).

In order to prepare the compound five parts of common rhombic phosphate of soda are dissolved in hot water together with two parts of crystallized phosphate of ammonia and the solution is allowed to cool. Transparent monoclinic prismatic

crystals separate out, having a specific gravity of 1.55 and possessing a strongly saline taste. They melt readily on heating giving off water and ammonia and leaving a residue of the dihydrogen sodium orthophosphate which again at a high temperature melts with loss of water, forming a clear liquid, and this on cooling yields a glassy mass of sodium hexametaphosphate. This substance is used largely as a blowpipe reagent.

108 Carbonates of Ammonium.—Commercial carbonate of ammonia, *sal-volatile*, or salt of hartshorn, forms the starting-point of these compounds. This substance was well known to the later alchemists who prepared it by the dry distillation of evaporated and decomposed urine, hartshorn, bones and other animal matters. Its preparation from sal-ammoniac was first described by Basil Valentine in the 15th century but long after this it was supposed that the volatile alkaline salts obtained from various sources possessed different medicinal power, and even up to the end of the 17th century *English drops*, which were really nothing more than carbonate of ammonia mixed with an ethereal oil, were sold at high prices and it was stated by some that the volatile alkali contained in this substance was prepared by the destructive distillation of silk, whilst others gave the remarkable receipt that five lbs. of skulls of persons who had been hanged or otherwise come to an unnatural end must be distilled with two lbs. of dried vipers, hartshorn, and ivory. More rational views concerning the composition of these compounds were arrived at towards the end of the 18th century. Dossie in his *Elaboratory laid Open* published in 1758 distinctly states that the same animal substances always yield an equally efficacious kind of volatile alkali.

Commercial Carbonate of Ammonia, commonly known as the sesquicarbonate, is obtained by subliming a mixture of two parts of chalk and one part of sal-ammoniac or sulphate of ammonia. This operation is conducted in iron retorts furnished with leaden receivers, and ten parts of sal-ammoniac yield from seven to eight parts of the carbonate. The salt is then resublimed with the addition of some water, and thus a white semi-transparent fibrous mass is obtained which has a strongly ammoniacal smell and a pungent caustic taste. This salt possesses the composition $N_3H_{11}C_2O_5$, and consists of a compound of hydrogen ammonium carbonate with ammonium carbamate; thus, $H(NH_4)CO_3 + NH_4CO_2NH_2$. By treating the salt with strong alcohol the carbamate can be dissolved whilst the ammonium carbonate remains undissolved.

This same decomposition takes place when the salt is exposed to the air, the carbamate undergoing slow volatilization.

The impurities liable to occur in the commercial salt are thio-sulphate, sulphate, and chloride of ammonium, lead from the receiver, and lime and calcium chloride from the chalk employed.

Normal Ammonium Carbonate, $(\text{NH}_4)_2\text{CO}_3 + \text{H}_2\text{O}$. Dalton first prepared this salt by treating sal-volatile with a quantity of water insufficient to dissolve it completely. It is also obtained when ammonium carbamate is dissolved in water:

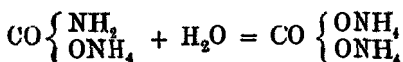

It is however most readily prepared by digesting the common commercial carbonate of ammonia for two hours at a temperature of 12° with strong aqueous ammonia and drying the crystalline powder which remains behind between blotting paper.

Transparent tabular or prismatic crystals are deposited from a solution prepared at a temperature of from 30° to 35° . These possess an ammoniacal odour, attract moisture from the air and become opaque from loss of ammonia and formation of hydrogen ammonium carbonate and water (Divers.)¹

Hydrogen Ammonium Carbonate, or *Bicarbonate*, $\text{H}(\text{NH}_4)\text{CO}_3$. Crystals of this salt are sometimes found in Patagonian guano and in the purifiers of gas-works. It is formed when the foregoing compound is allowed to lie exposed to the air, or when its solution is treated with carbon dioxide. It forms a white mealy powder, or, when slowly crystallized, large rhombic crystals, which have a cooling saline taste and do not smell of ammonia when in the dry state. At 60° it slowly undergoes decomposition with evolution of carbon dioxide, ammonia, and water. When it is more strongly heated in such a way that a small quantity of water condenses and the gases are not allowed to recombine, the ordinary commercial carbonate of ammonia is formed (Divers). This salt dissolves at 15° in 8 parts of water. Its solution when exposed to the air; as well when heated above 36° , loses carbon dioxide, but its saturated solution can be crystallized by cooling out of contact with air. It is not soluble in alcohol but if the alcoholic mixture be allowed to stand in the air carbon dioxide is evolved and normal carbonate of ammonia dissolves. It forms a double salt with the former compound having the composition $2\text{H}(\text{NH}_4)\text{CO}_3 + (\text{NH}_4)_2\text{CO}_3 + \text{H}_2\text{O}$, which may be most easily

¹ *Chem. Soc. Journ.* xxiii. 171.

obtained by treating the commercial salt at 30° with a moderate amount of tolerably concentrated ammonia and crystallizing. This double salt forms flat rhombic prisms or thin six-sided tables, smells strongly of ammonia and dissolves at 15° in 5 parts of water. It is decomposed by an excess of water with formation of the bicarbonate.

109 *Ammonium Cyanide*, NH_4CN . When a mixture of sal-ammoniac and dry ferrocyanide of potassium, or mercury cyanide, is heated, this salt sublimes in colourless cubes which smell of both ammonia and hydrocyanic acid. It is easily soluble in both water and alcohol and evaporates at a temperature of 36°. The vapour is inflammable and burns with a yellow flame. It is an extremely poisonous salt and decomposes, especially in the moist state, into azulmic acid.¹

Ammonium Cyanate, NH_4OCN , is formed when the vapour of cyanic acid is brought into contact with dry ammonia. It forms a flocculent crystalline mass, easily soluble in water and difficultly soluble in absolute alcohol. The salt is obtained in solution by decomposing lead cyanate with ammonia at a moderate temperature. This salt, as is well known, easily undergoes molecular change into isomeric urea.

Ammonium Thiocyanate, NH_4SCN , is formed by the dry distillation of organic bodies containing both nitrogen and sulphur. Hence it is always found in the ammoniacal gas liquors. According to Liebig it is best prepared by saturating two parts of ammonia of specific gravity 0.95 with sulphuretted hydrogen; six parts of the same ammonia and two parts of flowers of sulphur are then added, and this is mixed with the hydrocyanic acid obtained from the decomposition of six parts of yellow prussiate of potash. The mixture is then warmed for a considerable time on a water-bath, then boiled and filtered, and the filtrate evaporated to the crystallizing point. In this way 3.5 parts of ammonium thiocyanate are obtained:²

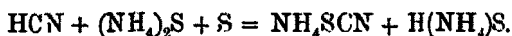

A simpler plan is that proposed by Millon: it consists in mixing together 15 parts of aqueous ammonia, 2 parts of carbon disulphide, and 15 parts of 88 per cent. spirits of wine. After standing for twenty-four hours one-third of the liquid is distilled off and the residue allowed to crystallize.³

¹ Vol. I., p. 659.

² *Ann. Chem. Pharm.* lxi. 126.

³ *Journ. Pharm.* [3]. xxxviii. 407.

Ammonium thiocarbonate is first formed in this reaction, and this on heating decomposes into sulphuretted hydrogen and the thiocyanate. Claus recommends that three to four times the above-mentioned quantity of carbon disulphide be used.¹

The salt is very easily soluble in both water and alcohol, and crystallizes in colourless plates. If 100 grams of this salt be dissolved in an equal weight of water at 17°, the temperature sinks to -12° (Rüdorff). The perfectly dry salt melts at 169°, and begins to decompose 1° above this point (Reynolds: see Vol. I., p. 654).

SULPHIDES OF AMMONIUM.

Ammonium Monosulphide, $(\text{NH}_4)_2\text{S}$, is obtained when two volumes of ammonia gas are mixed with one volume of sulphuretted hydrogen and the mixture cooled to -18°, or when potassium sulphide is treated with sal-ammoniac and the vapours led into a freezing mixture. It forms colourless glittering crystals soluble in water, which on exposure to the air pass into the next compound with evolution of ammonia. The aqueous solution of the monosulphide is obtained by saturating aqueous ammonia with sulphuretted hydrogen and then adding an equal volume of ammonia. Ammonium monosulphide is a strong sulpho-base.

Ammonium Hydrosulphide, $\text{H}(\text{NH}_4)\text{S}$, is formed when ammonia gas and sulphuretted hydrogen are brought together at the ordinary temperature. It solidifies at 0° to colourless needles or tables, which sublime at the ordinary temperature. An aqueous solution is prepared by saturating ammonia with sulphuretted hydrogen. The anhydrous compound, as well as its aqueous solution and that of the monosulphide, becomes yellow on exposure to air. This is due to oxidation, water and higher sulphides being formed.

Ammonium Tetrasulphide, $(\text{NH}_4)_2\text{S}_4$. This compound is obtained by cooling down the mother-liquor of the pentasulphide and saturating it in turn with ammonia and sulphuretted hydrogen. It forms crystals having a sulphur-yellow colour, which lose their transparency on exposure to the air, and yield on heating sulphur, ammonia, and ammonium hydrosulphide. It is easily soluble in water and alcohol.

Ammonium Pentasulphide, $(\text{NH}_4)_2\text{S}_5$, is obtained by mixing a solution of ammonium hydrosulphide with flowers of sulphur,

¹ Liebig's Ann. clxxix. 112.

and leading into this mixture first ammonia and then sulphuretted hydrogen until the cooled liquid solidifies. Then it is heated to a temperature of 50° , and allowed to cool in absence of air. Orange-yellow rhombic prisms are deposited, which dissolve in water with precipitation of plastic sulphur.

Ammonium Heptasulphide, $(\text{NH}_4)_2\text{S}_7$, is formed by the decomposition of the pentasulphide in the air. It is deposited in the form of ruby-red crystals when this solution is allowed to evaporate in the air :



On heating it decomposes, leaving a residue of sulphur. It is decomposed by water, but not so quickly as the pentasulphide.

The preparation of the volatile sulphur compounds of ammonia was known in early times. Thus, for instance, Basil Valentine states that a blood-red oil may be obtained by distilling together common sulphur, quicklime, and sal-ammoniac. He also says, "Take grey sulphur and quicklime a pound, sal-ammoniac a fourth part ; rub these together, when a splendid red oil is obtained, which fixes and refines." Beguin was also acquainted with this mode of preparation in the seventeenth century, and this salt was known as *spiritus sulphuric volatilis Beguinii*. Boyle in 1663 observed¹ that the vapours of this body possess the power of blackening metals, and he therefore termed it a volatile tincture of sulphur, and this same substance was known to the later chemists as *spiritus fumans Boylei*. This is a mixture of several sulphides of ammonia. Boerhaave in 1732 was the first to mention the fact that flowers of sulphur dissolved in ammonia. This substance was formerly known as volatile liver of sulphur. The preparation of the compound by leading sulphuretted hydrogen into ammonia was described by Kirwan in 1786.

OXYAMMONIUM COMPOUNDS.

III *Hydroxylamine* or *Oxyammonia*, like ammonia itself, combines directly with acids, forming crystallizable salts, of which the following are the most important :—

Oxyammonium Chloride or *Hydrochloride of Hydroxylamine*, $\text{NH}_4\text{OCl} = \text{NH}_3\text{O.HCl}$. This salt crystallizes from a hot saturated alcoholic solution in monoclinic prisms or plates. It

¹ *The Experimental History of Colours*, Experiment xxxiv. Boyle, *Op.* i. 754.

is very soluble in water, and less so in alcohol. On heating it decomposes into sal-ammoniac, hydrochloric acid, water, and nitrogen. When a concentrated aqueous solution of this salt is brought into contact with a solution of hydroxylamine in absolute alcohol, the crystalline salt, $(\text{NH}_3\text{O})_3\text{HCl}$, is precipitated; and when a concentrated solution of this latter salt is mixed with one of the normal salt, large well-formed crystals having the composition $(\text{NH}_3\text{O})_3\text{HCl}$ are deposited.

Oxyammonium Sulphate or *Sulphate of Hydroxylamine*, $(\text{NH}_4\text{O})_2\text{SO}_4$, crystallizes from aqueous solution in large monoclinic prisms, and is precipitated in the form of needles on the addition of alcohol to its aqueous solution.

Oxyammonium Nitrate or *Nitrate of Hydroxylamine*, $\text{NH}_4\text{O}\cdot\text{NO}_3$, is obtained by decomposing a solution of the chloride with silver nitrate, or one of the sulphate with barium nitrate. On evaporating the solution over sulphuric acid an oily liquid remains, which at -10° solidifies to a white crystalline mass, which melts again at the ordinary temperature. It is very easily soluble in water and in alcohol, and its aqueous solution decomposes on the water-bath with the evolution of red vapours.

METALS OF THE ALKALINE EARTHS.

Calcium.

Strontium.

Barium.

112 THE term earth was used by the older chemists to designate all those non-metallic substances which are insoluble in water and do not undergo alteration when exposed to a high temperature. It was afterwards observed that some of these, such as lime and magnesia, are closely allied to the alkalis, inasmuch as they possess an alkaline reaction and easily neutralize acids. These two bodies were termed *terras alcalinas*, and this name was subsequently applied to baryta and strontia. The alkaline earths, like the alkalis, were supposed to be elementary substances until Davy, in the year 1808, showed that each earth is a compound of oxygen and a metal.

CALCIUM, Ca = 39.9.

113 The very early application of mortar to building purposes shows that the ancients were well acquainted with the properties of lime and its preparation by the burning of limestone. In the writings of Dioscorides and Pliny we find a description given of the process of lime-burning, as well as of that of slaking lime. The name earth was at one time applied not only to lime and the other alkaline earths, but also to silica, alumina, and magnesia. Indeed the alchemists believed that all earths contained a common principle, known as primitive earth. For many years lime was not distinguished from other earths, but towards the middle of the eighteenth century it was noticed that different kinds of the so-called earths existed.

Calcium occurs very largely diffused in nature, especially as the carbonate which occurs in various forms, such as calc-spar,

arragonite, chalk, marble, limestone, coral, &c. United with carbonate of magnesia, as magnesian limestone or dolomite, it forms whole mountain ranges, and this compound, when crystallized, is known as bitter-spar. Many other minerals contain calcium carbonate in isomorphous mixtures; amongst these may be mentioned chalybite or brown-spar, $(\text{CaMgFeMn})\text{CO}_3$; mangano-calcite, $(\text{MnCaMg})\text{CO}_3$; plumbocalcite, $(\text{CaPb})\text{CO}_3$, &c. Calcium also occurs in large quantity as sulphate, either as the anhydrous compound, termed anhydrite, CaSO_4 , or in the hydrated form, as selenite or gypsum, $\text{CaSO}_4 + 2\text{H}_2\text{O}$. Calcium phosphate, combined with calcium chloride or calcium fluoride, occurs in the well-known minerals, apatite and osteolite. Calcium borate is also found in nature combined with many other metallic borates, whilst silicate of calcium occurs as an almost invariable constituent of all silicates. The solid constituents found in river and spring waters also consist mainly of calcium carbonate or calcium sulphate, and these, as well as phosphate and fluoride of calcium, are found in sea-water. Calcium salts form a never-failing component of the bodies of plants and animals, and cannot be replaced by any other salts. They accumulate in the leaves of plants; the roots and seeds, as a rule, yield only small quantities of them. The bones and teeth of animals contain large amounts of calcium phosphate, together with some carbonate and fluoride. Egg shells and the shells of mollusca, on the other hand, chiefly contain calcium carbonate. Calcium also occurs in the sun, in meteorites, and in certain of the fixed stars.

Preparation of Metallic Calcium. Calcium was first prepared by Davy by the electrolysis of calcium chloride in the presence of mercury, the calcium remaining as a metallic powder upon heating the amalgam thus obtained. It was first obtained in a coherent metallic mass by Matthiessen¹ in 1856. A mixture in the proportion of two molecules of calcium chloride to one molecule of strontium chloride, with a small quantity of sal-ammoniac, which mixture is more fusible than calcium chloride alone, is melted in a small porcelain crucible in which a carbon positive pole is placed, while a thin harpsichord wire wound round a thicker wire, and dipping only just below the surface of the melted salt, forms the negative pole. The metal calcium is then reduced in beads, which hang on to the fine wire, and may be obtained by withdrawing the negative pole every two or three

¹ *Journ. Chem. Soc.* viii. 28.

minutes, together with the small quantity of crust which is attached to it. Calcium may also be obtained by the modification of the above process described under strontium. Frei obtained it, by the electrolysis of the chloride, in globules weighing from 2.4 to 4 grams. Another process for obtaining the metal is by fusing a mixture of one part of sodium with seven parts of fused iodide of calcium in a closed iron crucible. The temperature is first raised to a dull red-heat, and afterwards to a bright red-heat.¹ Another process is to fuse three parts of calcium chloride with four parts of zinc and one part of sodium. In this way an alloy of zinc and calcium is produced, which is then heated in a crucible made of gas carbon until the zinc volatilizes when the fused calcium is found in the form of a button (Caron).²

Calcium is a yellow metal, which gives a yellow streak on touch-stone. It is harder than lead, is tenacious and malleable, and has a specific gravity of 1.5778 (Bunsen and Matthiessen). According to Frei it has the colour of aluminium, and is very brittle.³ It may be preserved in perfectly dry air for many days without undergoing oxidation; in moist air it is readily oxidized. When heated to redness in the air, it burns with a very bright yellow light, and when thrown into water it decomposes the water with violent evolution of hydrogen.

CALCIUM AND OXYGEN.

114 *Calcium Monoxide* or *Lime*, CaO , is formed in the pure state by the ignition of the pure carbonate, as Iceland-, or calc-spar, or white marble, in a crucible which has a hole at the bottom in order that the furnace gases may pass through it and carry off the carbon dioxide; otherwise the decomposition is not complete, as calcium carbonate undergoes no change in composition, in an atmosphere of carbon dioxide gas, even when heated to whiteness.

On the large scale lime is burnt in kilns, the interiors of which are usually egg-shaped. The limestone is mixed up with coal or other combustible matter, one bushel of coal generally sufficing to make five or six bushels of lime. In some cases an arch is formed over the fire-grate with lumps of limestone, the kiln filled up with smaller pieces, a fire kindled

¹ Liés Bodart, and Jobin, *Ann. Chem. Phys.* [3] liv. 364.

² *Ann. Chem. Pharm.* cxv. 355.

³ *Ann. Chem. Pharm.* 183, 367

below the arch, and this kept up for thirty-six to forty-eight hours. The kiln is then allowed to cool, the lime removed, and a fresh charge introduced. Recently an improved and continuous process of lime burning has been introduced. In these kilns, of which there are several different kinds, the charge of limestone and coal is added from time to time at the upper part of the kiln, and the quicklime withdrawn at the lower part. A great saving of fuel is thus effected, and the smoke which is always given off from the common kiln is, in the improved kiln, drawn into a high chimney and completely burnt.

Magnesian limestones require less fuel than pure limestones. When a limestone contains much clay, care must be taken to prevent the heat becoming too intense, as such limestone is apt to vitrify, and is then said to be dead burnt. Such lime, if not heated too strongly, slakes slowly, and is termed poor lime, whereas a pure lime which slakes readily is termed rich or fat lime.

Pure lime is a white amorphous mass, which does not fuse even at the temperature of the oxyhydrogen flame, but it emits an intense light when thus heated, giving rise to the lime-light. Its specific gravity is 3.08. Lime has recently been obtained crystallized in cubes by heating calcium nitrate in a porcelain flask (Brügelmann).¹ On exposure to the air it absorbs water and carbon dioxide. In addition to its technical use as a constituent of mortars and cements, quicklime is employed in the laboratory for drying gases and liquids, and in the analysis of organic compounds containing chlorine, bromine, and iodine.

Calcium Hydroxide, $\text{Ca}(\text{OH})_2$. This substance, also known as hydrate of lime, or slaked lime, is obtained by pouring about one-third its weight of water on to fresh well-burnt quicklime. So much heat is evolved in the process that fires have not unfrequently been traced to it. This production of heat can be very well shown by strewing a few grains of gunpowder on to the lime whilst it is being slaked, when the gunpowder will take fire. Slaked lime is a white impalpable powder, having a specific gravity of 2.078 (Filhol). Calcium hydroxide is likewise obtained as a white precipitate, when a solution of caustic potash or soda is added to a tolerably strong solution of calcium chloride. If a very strong or saturated solution of calcium chloride be employed in the above experiment, the whole mass becomes solid. This fact was observed in 1686 by Francisco Lana, and described by him as the "chemical miracle." Calcium hydroxide dissolves more

¹ *Pogg. Ann.* 1877, p. 466.

readily in cold than in hot water; 100 parts of water at 15°G dissolve 0.1368 parts, and at 100° 0.0752 parts (Wittstein). The clear solution, evaporated in a vacuum over sulphuric acid, deposits the hydroxide either in the form of small tables or of small prismatic crystals.

The solution of calcium hydrate, usually known as lime-water, possesses an alkaline reaction and taste. It quickly absorbs carbon dioxide from the air, and is used in medicine and in the laboratory. As the ordinary slaked lime often contains small quantities of baryta and strontia together with soluble salts of the alkalis, it is usual to treat the powder several times with water, and only to employ the last solution.

Milk of Lime is calcium hydroxide suspended in water.

Calcium Dioxide, CaO_2 , was discovered by Thénard, who obtained it by precipitating lime-water with hydrogen dioxide. In order to procure the substance in the pure state the hydrogen dioxide must be added in excess to lime-water. The precipitate possesses the composition $\text{CaO}_2 + 8\text{H}_2\text{O}$, and consists of microscopic quadratic tables or prisms, which are difficultly soluble in water and insoluble in alcohol.¹ On exposure to the air the crystals effloresce, and when heated to 130° they lose their water, leaving behind a light powder of the anhydrous oxide. On further heating the substance loses half its oxygen without fusing.

SALTS OF CALCIUM.

115 *Calcium Chloride*, CaCl_2 . Isaac Hollandus in the fourteenth century describes, under the name of *sal-ammoniacum fixum*, a substance which he obtained by heating together sal-ammoniac and lime. Homberg in 1693 noticed that this salt, when fused, becomes phosphorescent, and hence it was long known as Homberg's phosphorus. Calcium chloride is found in solution in sea-water, and in many mineral springs. It likewise occurs as a constituent of a few minerals, such as tachhydrite, $\text{CaCl}_2 + \text{MgCl}_2 + 12\text{H}_2\text{O}$, and apatite $3\text{Ca}_3(\text{PO}_4)_2 + \text{CaCl}_2$.

In order to prepare pure chloride of calcium, chalk or white marble is dissolved in hydrochloric acid until the latter is nearly saturated. Chlorine water is then added, in order to oxidize any iron or manganese compounds which may be present. These impurities are next precipitated by the addition of milk of lime,

¹ *Ann. Chim. Phys.* viii. 313.

and the precipitate is filtered off. The slightly alkaline solution is then acidified with hydrochloric acid, and the solution evaporated either to the point of crystallization or to dryness. Chloride of calcium is obtained on the large scale as a bye-product in several manufacturing processes, as in that of chlorate of potash, in the ammonia-soda process, &c.

The hydrated salt crystallizes from a saturated solution in large hexagonal prisms, which have the composition $\text{CaCl}_2 + 6\text{H}_2\text{O}$. These melt at 290° , and deliquesce rapidly in the air, forming a thick liquid, to which the name of *oleum calcis* was formerly given. The crystals dissolve in water, producing a considerable diminution of temperature; and if $1\frac{1}{2}$ parts of the crystallized salt be mixed with 1 part of snow the temperature sinks to -48° . Heated to 200° this hydrate loses four molecules of water, and a white porous hygroscopic mass remains behind, which is largely used as a means of drying gases and organic liquids. If this hydrate is heated more strongly, the anhydrous salt is obtained. This latter melts at a red-heat, and solidifies on cooling to a crystalline mass, which has a specific gravity of 2.205, and is also used as a desiccating agent. It dissolves in water with evolution of heat. 100 parts of water dissolve the following quantities (Kremers):

At	10°	40°	60°
CaCl_2	63.35	120.48	138.89.

A solution of 50 parts of the anhydrous salt in 100 parts of water boils at 112° , one containing 200 per cent. boils at 158° , and one containing 325 per cent. boils at 180° . Such solutions are employed as baths for constant temperatures above 100° .

Calcium chloride absorbs dry ammonia, giving rise to a voluminous powder having the composition $\text{CaCl}_2 + 8\text{NH}_3$, which on exposure to the air, on solution in water, or on heating, loses ammonia, and which takes fire when thrown into chlorine gas.

If chloride of calcium solution is boiled with slaked lime and the solution filtered hot, a basic salt separates out on cooling in long white needle-shaped crystals, having the composition $\text{ClCaO} \cdot \text{Ca}(\text{OH}) + 7\text{H}_2\text{O}$.

Calcium Bromide, CaBr_2 , and *Calcium Iodide*, CaI_2 , are salts very similar in their properties to calcium chloride.

Calcium Fluoride, CaF_2 , occurs as a mineral known as fluor spar, which has from early times been used in the fluxing of

ores, whence its name is derived. Agricola says: "Fluores lapides gemmarum similes sed minus duri, qui ignis calore liquescunt;" and then further: "Dum metalla excoquantur, adhibere solent, reddunt enim materiam in igne non paulo fluidiorem."

Fluor-spar occurs largely in Derbyshire in veins, especially in the celebrated limestone caves in the Castleton valley. It is there commonly known as *Blue John*, and one of these large caverns is termed the Blue John cave. It is also found in Saxony and in many other countries. It crystallizes in cubes and octohedrons, and in combinations of these two forms, or in other forms belonging to the regular system. In the pure condition it is colourless; in general, however, it has a blue, violet, red, green, yellow or brown colour. Those samples which have a bright colour are worked up into vases, dishes, cups, &c. Calcium fluoride also occurs in small quantity in the ashes of certain plants, in bones,

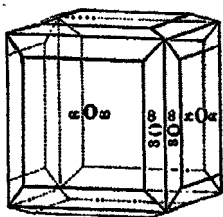

FIG. 39.

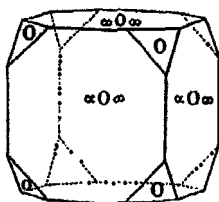

FIG. 40

in the enamel of the teeth, in sea-water and in the water of certain mineral springs. It is very nearly insoluble in water and dilute acids.

When precipitated calcium fluoride, obtained by mixing a solution of calcium chloride with one of a soluble metallic fluoride, is heated with water slightly acidified with hydrochloric acid, the precipitate is found to consist of microscopic octohedrons.

The property which fluor-spar possesses of becoming luminous when heated, giving rise to the term fluorescence, was first mentioned by Elsholz in 1677, and further described by Leibnitz in 1710.

Calcium Chlorate, $\text{Ca}(\text{ClO}_3)_2$. This substance is formed when chlorine is led into hot milk of lime. It is prepared in the pure state by precipitating potassium chlorate with calcium silicofluoride. It is very deliquescent, and crystallizes with difficulty.

Chloride of Lime or Bleaching Powder. This well-known body was originally considered to be a compound of chlorine and lime. Balard, in 1834, was the first to give an explanation of the constitution of this compound, and his explanation has from that time been generally adopted. According to this view bleaching powder is a mixture of calcium hypochlorite and calcium chloride, $\text{Ca}(\text{OCl})_2 + \text{CaCl}_2$. Another view of the constitution of bleaching powder has been taken by Odling. He looks upon this substance as a kind of double salt, $\text{Ca} \left\{ \begin{array}{l} \text{Cl} \\ \text{OCl} \end{array} \right.$, being at the same time a chloride and a hypochlorite.

Chloride of lime is obtained by the action of chlorine gas upon dry slaked lime. When chlorine is passed into milk of lime, a reaction which is analogous to the formation of Eau de Javelle (Vol. I. p. 264) takes place:



If, however, dry slaked lime be employed, a large proportion of the lime remains unaltered. This fact was formerly explained by the supposition that the calcium chloride produced, forms a coating round the particles of lime which prevents the further action of the chlorine. But even if the mixture be from time to time well rubbed down in a mortar, and then again treated with chlorine, it is not possible to obtain a material containing more than 40 per cent. of available chlorine. Hence this substance would appear to be a mixture of basic salt with chloride of calcium, according to the formula:

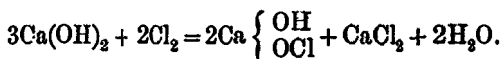

If water be added to this product the soluble chloride dissolves and the basic hypochlorite decomposes as follows:¹

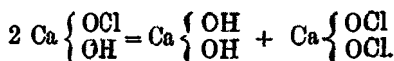

Bleaching powder is obtained on a very large scale in the alkali works as a means of employing the residual hydrochloric acid. For the purpose of evolving the chlorine required for the manufacture large stills are employed, shown in Figs. 41 and 42. These are made of Yorkshire flag soaked in tar, the joints being rendered tight by india-rubber rope on which the stone rests, as

¹ Stahlshmidt, *Dingl. Polyt. Journ.* ccxx. 243.

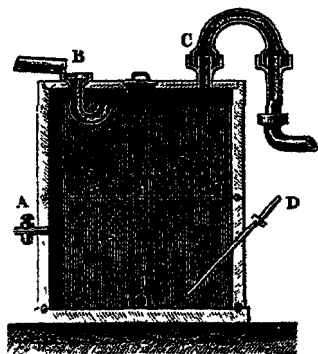

FIG. 41.

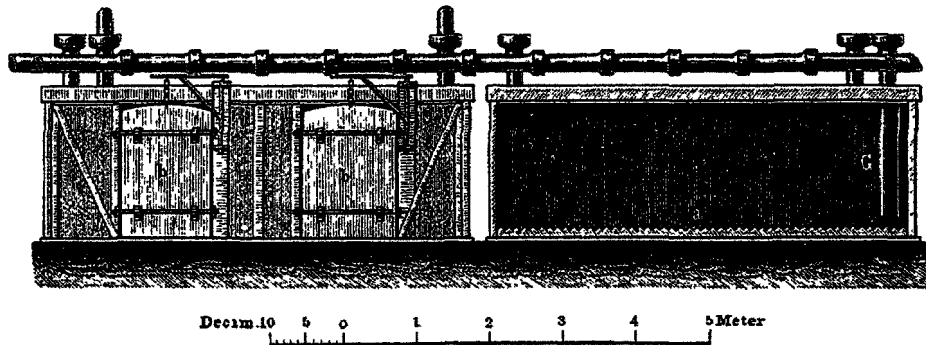

FIG. 43.

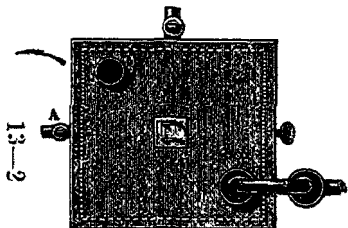

FIG. 42.

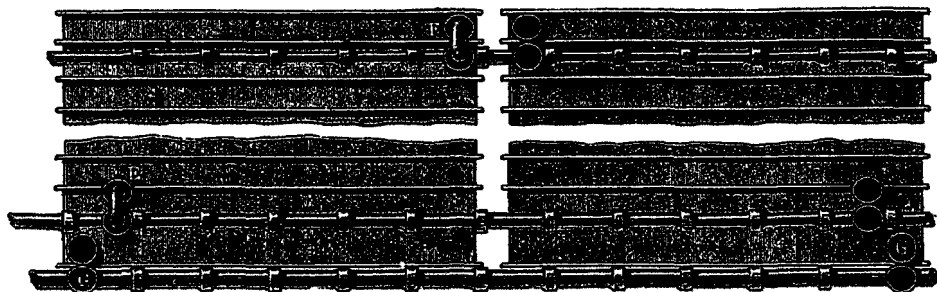

FIG. 44

shown in Fig. 41. The material now usually employed for the generation of chlorine from hydrochloric acid, is the manganese dioxide, obtained by precipitation in what is known as Weidon's process. (A) is the tap for admitting the hydrochloric acid; (B) is the inlet to admit the finely divided precipitated manganese mud; (C) the lute and pipe to carry off the chlorine; (D) a pipe made of ebonite through which steam is led for the purpose of heating the mixture. Fig. 42 shows the plan of the same chlorine-still.

The chlorine gas passes from the still into large chambers of which Fig. 43 shows the elevation and end-section, and Fig. 44 the corresponding plan. These chambers are sometimes made of lead, sometimes of Yorkshire flag, and sometimes of iron plate covered with asphalt varnish. They are generally sixty feet long, eighteen feet wide, and seven feet in height. Dry slaked lime is filled into the chamber in such quantity that a layer of from four to five inches covers the bottom. The whole is ridged with a rake made for the purpose, the apex of each ridge being from five to six inches, and the bottom of the valley from two-and-a-half to three inches above the floor. The chlorine is delivered through the pipe and lute (E). Considerable distance is generally allowed between the chlorine-still and the chamber in order to permit of the condensation of moisture and the cooling of the gas. (F) is the exit pipe connected with a fresh lime chamber for the absorption of the surplus chlorine. (G) is an exhaust pipe for drawing off the last remaining quantities of the unabsorbed chlorine when the operation is complete. The exterior view, Fig. 43, shows the doors and bolts and the gallowes for the swinging of the doors. The section shows the lime lying on the bottom of the chambers, whilst the arrangement of the pipes and lutes is seen in Fig. 44. In these chambers the absorption of chlorine occupies about six days. After the lime has been placed upon the floor of the chamber, chlorine is turned on until the chamber is full, as seen by windows placed at each end, the air and any surplus chlorine escaping from the chamber and passing by the circulating pipes into the next or some other chamber where there is more fresh lime. The air which is displaced from this, escapes either into the atmosphere directly or into a third chamber. When the first chamber has been filled with chlorine it is allowed to stand for about two days, during which time the gas is completely or nearly completely absorbed, and the lime is then found to contain from 25 to 30 per

cent. of available chlorine. Any unabsorbed gas is then drawn off by means of the exit pipe (g), the doors are opened, and workmen enter and turn the lime. After turning, the doors are closed, and more chlorine is admitted, the quantity being left to the judgment of the man in charge. Usually, however, enough is sent in to raise the amount of chlorine after absorption for a second period of two days to from 36 to 37 per cent. The unabsorbed chlorine is then drawn off as before, and the powder packed and sent to market. Occasionally a third treatment is necessary, but this rarely occurs except in hot weather, when the absorption of the chlorine takes place more slowly than usual.

In the old process of manufacture where native manganese was always employed, from 90 to 100 parts of the ore, containing 60 per cent. of the dioxide, yielded 100 parts of bleaching powder of 35 per cent. of available chlorine. By Weldon's process nearly all the manganese dioxide can be regained from the residual chloride of manganese, and is employed again for the evolution of chlorine. A certain loss, however, takes place, and from 5 to 8 per cent. of native manganese ore containing 60 per cent. of MnO_2 has to be added together with the regenerated manganese dioxide in order to produce 100 parts of bleaching powder of 35 per cent. strength. The quantity of hydrochloric acid employed for the production of one ton of bleaching powder varies in different works according to the care with which the process is carried on. The usual practice is to make one ton of bleaching powder from the acid evolved by the decomposition of three-and-a-half tons of salt. Some manufacturers, however, use considerably less than this, and Mr. Weldon believes that the acid obtained from two tons of salt is sufficient for the purpose. In practice it is found that 11 cwt. of caustic lime are required to form one ton of bleaching powder. In the preliminary slaking and dressing of the lime probably $1\frac{1}{2}$ cwt. is lost. The lime ready for use contains about 25 per cent. of water and 1.2 per cent. of carbon dioxide, so that 20 cwt. of bleaching powder would be made up as follows :

Lime	9.5 cwt.
Water: 25 per cent. on the 100 of hydrated lime	} 3.2 "
Chlorine: 35 per cent. on the finished B. P.—say	} 7.3 "

20.0 „ B. P.

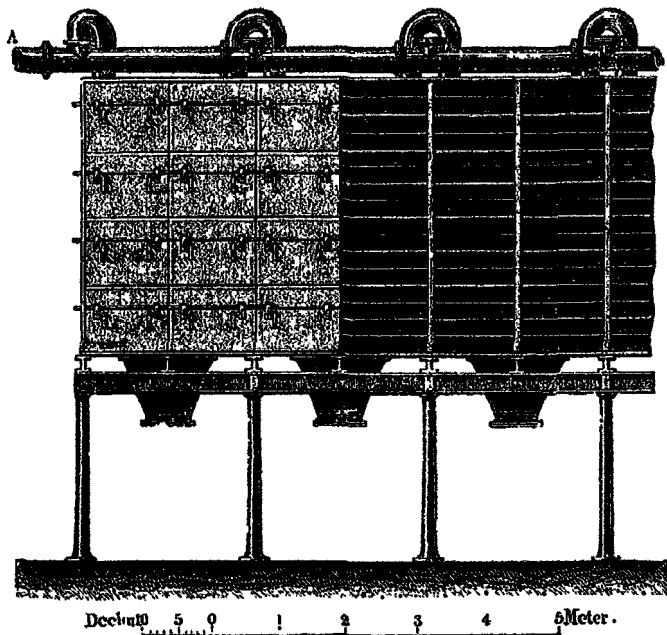

FIG. 45.

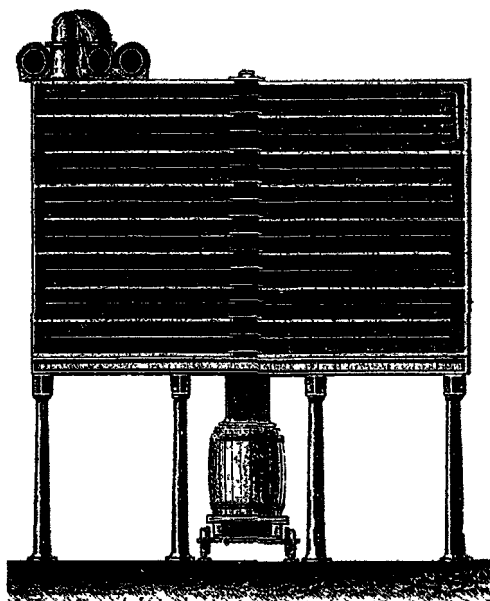

FIG. 46.

An improved form of bleaching powder chamber has been invented by the late Mr. Deacon for the manufacture of bleaching powder according to his patented process. The principles of this process have already been referred to in Vol. I., p. 114, chlorine being obtained directly from the gaseous hydrochloric acid of the salt-cake furnace without the employment of oxide of manganese. In this process considerable quantities of nitrogen pass into the chamber together with the chlorine, so that it is necessary that a graduated system of absorption should be carried out; the lime which is nearly saturated with chlorine, being exposed to the strongest gas whilst the last traces of chlorine are extracted by layers of lime comparatively fresh. These chambers are shown in elevation and section in Figs. 45 and 46. Chlorine gas mixed with nitrogen passes in through the tube (A), being drawn over the lime by means of exhausters. Each chamber or block is divided by vertical walls into 14 squares; each section contains 19 shelves 20 feet long by 4 feet wide, and the lime is spread on these to the depth of about five-eighths of an inch. Part of the elevation shows the doors, which form the sides of the chamber, in position; the other part shows the arrangement of the shelves seen when the doors are down. The end section shows the mode in which the shelves are arranged, and the way in which the chlorine is divided into streams during its passage through the lime. When the lime in one chamber has come up to strength, small plates on each shelf are removed from the top, and the bleaching powder simply falls into a barrel placed on a tram-car beneath, and in this way the product is easily packed.

Commercial bleaching powder contains from 20 to 35 per cent. of available chlorine. It forms a homogeneous white powder, possesses a faint smell of hypochlorous acid, and gradually becomes moist on exposure to the air. When well mixed with water it forms a creamy liquid. On exposure to the air it gradually decomposes with absorption of water and carbon dioxide. When preserved in closed vessels it undergoes decomposition under circumstances which are at present undetermined; and this decomposition is occasionally so sudden, and the rise of temperature so great, that explosions sometimes occur. When heated it is decomposed into calcium chloride and calcium chlorate, and the latter compound evolves oxygen on a further application of heat. When a concentrated aqueous solution of chloride of lime is allowed to evaporate over sulphuric acid

in a vacuum crystals of calcium hypochlorite are obtained, having the composition $\text{Ca}(\text{OCl})_2 + 4\text{H}_2\text{O}$, but, owing to the ease with which it undergoes decomposition, this salt is very difficult to obtain in the pure state.¹

Bleaching powder as well as the solution obtained by the action of chlorine on milk of lime is largely employed in the bleaching of cotton goods and of paper pulp.

The operations of bleaching cotton cloth are as follows :—

1. Boiling or "bucking" the cloth with milk of lime; 14 lbs. of cloth requiring about 1 lb. of lime, water being added to this in sufficient quantity to cover the cloth. In this process the resinous matters in the fibre are converted into lime soaps.

2. Washing to remove lime and soluble salts.

3. Souring in dilute hydrochloric or sulphuric acid of specific gravity 1.0075 to decompose lime-soaps.

4. Washing to remove acid.

5. Bucking the cloth in dilute caustic soda-lye (170 lbs. of soda-ash and 80 lbs. of resin-soap to 3,500 lbs. of cloth) to remove fatty matters and dirt.

6. Washing and subsequent immersion in a clear dilute solution of bleaching powder of specific gravity 1.0025. This is called "chemicking."

7. Souring in very dilute hydrochloric or sulphuric acid of specific gravity 1.0075, then washing and drying.

The decomposition which takes place when acid is brought into contact with bleaching powder is thus represented :

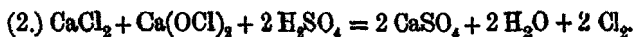

The theory of bleaching has already been explained, (see Vol. I. page 266).

115 Chlorimetry. As chloride of lime is largely used in manufacturing, it becomes important to be able to determine the amount of *available chlorine* which it contains, that is, the amount of chlorine which is evolved when hydrochloric or sulphuric acid is added to it. For the purposes of the manufacturer, it is especially important to possess a method by means of which this available chlorine can be quickly and accurately determined. Of the many methods which have been proposed

¹ Kingzett, *Journ. Chem. Soc.* xxviii. 404.

we shall mention here only those which have been successfully introduced into practice.

Gay-Lussac,¹ in 1835, suggested a method which is still often employed in works. This depends upon the fact that chlorine in the presence of water oxidizes arsenious acid to arsenic acid :

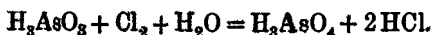

The solution of bleaching powder is added to a given volume of the arsenious acid solution until a solution of indigo is bleached by the free chlorine. By this process a small quantity of chlorine is often lost, and Penot² has introduced an improvement into the process. He employs an alkaline solution of arsenic trioxide obtained by dissolving 6.98 grams of As_2O_3 and 30 grams of crystallized carbonate of soda in 200 cbc. of water and then diluting this to one liter. In practice, ten grams of bleaching powder are weighed out. To this a small quantity of water is added in a mortar, and the whole is washed by degrees into a liter flask which is then filled up with water to one liter. This liquid is well mixed, and 50 cbc. of the turbid liquid brought into a beaker glass; the arsenite solution is then added from a burette, until one drop of the liquid does not any longer turn blue a paper steeped in iodide of potassium and starch. During the addition of the arsenite solution a drop of the liquid must be brought from time to time on to the iodized starch paper, and when the blue colour begins to be only faintly seen, the arsenite solution must be added very gradually. In this way the exact point of complete oxidation can be readily reached. One cbc. of the arsenite solution corresponds to 0.005 gram of chlorine, so that the number of cbc. employed gives at once the percentage of available chlorine which the bleaching powder contains.

Another useful method for the valuation of bleaching powder, which is often employed, is that suggested by Graham and worked out by Otto. It depends upon the following reaction :

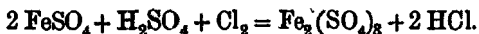

For this purpose 0.784 gram of pure crystallized proto-sulphate of iron (ferrous sulphate) is dissolved in water, a little sulphuric acid added and the bleaching powder solution dropped in from a burette until all the ferrous salt is converted into ferric salt. The completion of the reaction is ascertained by

¹ *Ann. Chim. Phys.* [2] ix. 225.

² *Journ. Prac. Chem.* lix. 59.

bringing a drop of the solution together with a drop of potassium ferricyanide on a white plate, until no further blue coloration is observed. The calculation here is very simple, as the above quantity of ferrous sulphate, $\text{FeSO}_4 + 7\text{H}_2\text{O}$, corresponds to 0.1 gram of chlorine.

Wagner's¹ modification of Bunsen's iodometric method (Vol. I. p. 312), depends upon the fact that iodine and potassium thiosulphate decompose one another as follows:

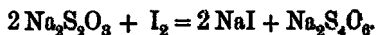

For this purpose a standard solution of the thiosulphate is prepared and then added from a burette to the bleaching powder solution, to which a solution of potassium iodide has previously been added. The reaction is complete when the brown colour of the iodine disappears.

Calcium Sulphite, CaSO_3 , is obtained by mixing a solution of a calcium salt with that of a normal sulphite. It forms a white powder which dissolves in 800 parts of water. It is easily soluble in sulphurous acid, and if this solution be allowed to stand exposed to the air, six-sided needles separate out which have the composition $\text{CaSO}_3 + 2\text{H}_2\text{O}$. A solution of this salt in aqueous sulphurous acid is met with in commerce, under the name of bisulphite of lime. It is obtained by passing sulphur dioxide into milk of lime, and is used by brewers to give beer stability.

117 *Calcium Sulphate*, CaSO_4 , occurs in nature in the anhydrous state in the mineral anhydrite which is often found in limestone rocks, or together with deposits of common salt. More generally, however, the substance occurs as gypsum, $\text{CaSO}_4 + 2\text{H}_2\text{O}$, found frequently in large monoclinic crystals and known as selenite. The crystalline form of selenite is shown in Figs. 47 to 49. The crystals are frequently twins, and then exhibit the peculiar form shown in Fig. 50.

It also occurs as fibrous gypsum or satin-spar, and as crystalline gypsum or alabaster. This substance was known from early times as a mineral closely resembling calc-spar, because like the last it becomes brittle on burning. In 1746 Pott described these two substances as being different earths, and stated that some chemists assumed that the substance artificially produced by the union of sulphuric acid with lime

¹ *Dagbl. Polyt. Journ.* cliv. 146.

was gypsum, and termed it *gypsum artefactum*; in 1750 Marggraf showed that these two substances were identical.

Gypsum has a specific gravity of 2.31. When heated to 110° – 120° it loses the whole of its water and thus is converted into *burnt gypsum* or *plaster of Paris*. This substance combines with water, evolves heat, and subsequently solidifies. Upon this property depends the technical use of gypsum. When gypsum is heated above 200° it becomes *dead-burnt*, that is, it can only take up water slowly and does not harden. After it has been heated to 500° it also combines with water very slowly, the combination going on for several weeks, but the product is a hard mass, which is translucent like alabaster and is more dense than ordinary gypsum. If it is then heated to 150° it passes into the condition of ordinary burnt gypsum.¹

One thousand parts of water dissolve at 0° 2.05, at 35° 2.54, and above 100° less than two parts of the salt. Its point of

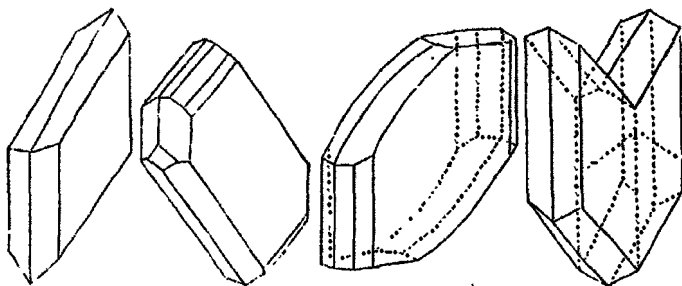

FIG. 47.

FIG. 48.

FIG. 49.

FIG. 50.

maximum solubility therefore lies about 35° (Poggiale). In the presence of ammoniacal salts and common salt gypsum is more readily soluble. According to Anton, 1,000 parts of a saturated solution of common salt dissolve 8.2 parts of gypsum. Gypsum is tolerably soluble in boiling hydrochloric acid and nitric acid, and separates out from the acid solution on cooling in glittering silky needles. When heated with sulphuric acid to 100° it is changed into a porous mass, of which a part dissolves and separates out again on cooling. This consists of microscopic prisms, which have the composition $\text{CaSO}_4 + \text{H}_2\text{SO}_4$: it is decomposed by water into its two constituents. Gypsum dissolves very readily in a solution of sodium thiosulphate.

¹ Schott, *Dingl. Polyt. Journ.* ccii. 52 & 355.

Gypsum is largely used as a manure, as a cement, for ornamental plaster-work, and for making plaster casts. The artificial salt prepared by precipitating a calcium chloride solution with dilute sulphuric acid, is now known under the name of *perl hardening* or *annaline*, and is used largely by paper makers as a filling for writing paper.

Calcium Potassium Sulphate, $\text{CaSO}_4 + \text{K}_2\text{SO}_4 + \text{H}_2\text{O}$. This compound is formed when the solutions of the two salts are mixed together (H. Rose). When an intimate mixture of equal weights of the anhydrous salts is stirred up with less than their weight of water, the mass becomes so suddenly solid that it cannot be poured out of the vessel. If four to five parts of water are employed, the solidification takes place somewhat more slowly but still more rapidly than in the case of gypsum alone. Casts made of this mixture possess a polished surface and are in this respect superior to those made of gypsum.

Calcium Sodium Sulphate, $\text{CaSO}_4 + \text{Na}_2\text{SO}_4$, occurs in nature as the mineral glauberite. Sodium sulphate does not act upon plaster of Paris as potassium sulphate does. If, however, a mixture of one part of precipitated calcium sulphate and fifty parts of Glauber's salt be heated to 80° with twenty-five parts of water, a mass of needle-shaped crystals is obtained, which have the formula $\text{CaSO}_4 + 2\text{Na}_2\text{SO}_4 + 2\text{H}_2\text{O}$, and these when further heated are transformed into small crystals of glauberite (Fritzsche).

Calcium Thiosulphate, $\text{CaS}_2\text{O}_3 + 6\text{H}_2\text{O}$, is prepared by heating calcium sulphate with sulphur and water. It forms oblique six-sided prisms, soluble in their own weight of cold water. When the solution is heated to 60° the salt is decomposed with evolution of sulphur. This salt is used in the production of antimony cinnabar, Sb_2OS_2 .

118 *Calcium Nitrate*, $\text{Ca}(\text{NO}_3)_2$. The alchemist Baldewein or Balduinus first prepared this compound whilst searching for a method of absorbing the "Spiritus mundi." He dissolved chalk in nitric acid, and observing that the solid product became rapidly moist on exposure to air, concluded that this substance would prove to be of great power. In the year 1674 he noticed that the solid residue after being heated and then exposed to sunshine appeared luminous in the dark, and from this time the compound prepared as above was termed Baldwin's phosphorus. Calcium

nitrate is very soluble in alcohol as well as in water, and is a deliquescent salt. The anhydrous salt is a white porous mass, sometimes used in place of calcium chloride for drying organic liquids. It is often found as an efflorescence on the walls of stables and other places through which urine and other organic liquids percolate. The name lime-saltpetre, or wall-saltpetre, has been given to this salt, which was formerly universally employed for the artificial preparation of nitre.

Phosphates of Calcium. Normal Calcium Orthophosphate or Bone-phosphate, $\text{Ca}_3(\text{PO}_4)_2$. This compound occurs together with calcium fluoride in apatite, $3\text{Ca}_3(\text{PO}_4)_2 + \text{CaF}_2$ or $\text{Ca}_3(\text{PO}_4)_2 + \text{Ca}_2(\text{PO}_4)\text{F}$; in which a portion of the fluorine is sometimes replaced by chlorine. Phosphorite and estramadurite are massive varieties of apatite which occur in Estramadura, in Spain. Coprolites, which are found in many sedimentary deposits, and doubtless have an animal origin, consist mainly of calcium orthophosphate. Another pure form of the same compound is the mineral osteolite, and it also occurs as sombreroite, a mineral found on some of the small islands of the Antilles, especially Sombrero, and containing crystals of the mineral ornithite $\text{Ca}_3(\text{PO}_4)_2 + 2\text{H}_2\text{O}$. Calcium phosphate is also the chief inorganic constituent of bones, forming about 80 per cent. of burnt bones; the other constituents being magnesium phosphate, calcium carbonate, and calcium fluoride.

Pure calcium phosphate is obtained as a white precipitate by adding an excess of common phosphate of soda to an ammoniacal solution of chloride of calcium. It is nearly insoluble in water but is decomposed on long boiling into an insoluble basic salt, $\text{Ca}_3(\text{PO}_4)_2 + \text{Ca}_2(\text{PO}_4)\text{OH}$, and a soluble acid salt which dissolves. This decomposition takes place slowly in the cold, and for this reason an exact determination of the solubility of the orthophosphate is impossible.¹ Calcium orthophosphate dissolves readily in water containing ammoniacal salts, sodium nitrate, common salt, and other salts. It is also readily soluble in all acids, even in aqueous carbonic acid. This explains the absorption of calcium phosphate by the roots of plants, which accumulate it in the seeds and fruit.

Mono-hydrogen Calcium Orthophosphate, HCaPO_4 . When a solution of calcium chloride is mixed with one of ordinary phosphate of soda, a white crystalline precipitate of the above

¹ R. Warrington, *Journ. Chem. Soc.* [2] xi. 983.

compound containing two molecules of water of crystallization is thrown down. This compound occurs in urinary concretions, and is sometimes deposited from urine in microscopic crystals grouped in rosettes or stellæ, and known as stellar phosphate.

Tetra-hydrogen Calcium Phosphate, $H_4Ca(PO_4)_2$. This salt is obtained in rhombic tables by dissolving either of the foregoing salts in the requisite quantity of phosphoric acid and allowing the solution to evaporate spontaneously. If this be treated with cold water the hydrated mono-hydrogen phosphate $HCaPO_4 + 2H_2O$ is formed, whilst with boiling water the same anhydrous salt is produced (Erlenmeyer).

Superphosphate of Lime. A mixture of the last-mentioned compound and sulphate of lime is manufactured on the large scale, and known in commerce as *superphosphate of lime*. It is usually prepared by acting on bone-ash, coprolites, phosphorites, or other form of mineral phosphate by two-thirds of its weight of sulphuric acid. This mixture is used for the preparation of phosphorus (Vol. I. 460), and is also largely employed as a manure, especially for root crops.

Calcium Hypophosphite, $Ca(PO_2H_2)_2$, is used in medicine and is prepared by boiling phosphorus with milk of lime. On evaporating the clear solution, the salt crystallizes in bright, flexible, four-sided prisms, which are insoluble in alcohol.

Calcium Silicates. These compounds exist in almost all mineral silicates. Certain of the latter consist mainly, if not altogether, of silicates of calcium (and isomorphous metals). Amongst these the more important are wollastonite $CaSiO_3$, okenite $H_2CaSi_2O_6 + H_2O$, xonaltite $4CaSiO_3 + H_2O$, gurolite $H_2Ca_2Si_3O_9 + H_2O$, and apophyllite $4H_2CaSi_2O_6 + KF + 4H_2O$.

119 *Calcium Carbonate*, $CaCO_3$. This compound occurs widely distributed and in enormous masses in nature forming whole mountain ranges, being found as limestone of various kinds, marble, calc-spar, and chalk. It also forms the greater part of egg-shells, shells of mollusca, coral, and is contained together with phosphate of lime in burnt bones. Calcium carbonate is dimorphous: it exists in the first place as *calc-spar*, its specific gravity varying from 2.70 to 2.75, and it crystallizes in hexagonal and chiefly hemihedral forms. Some of the more important of these are seen in Figs. 51 to 59, a common twin-crystal being shown in Fig. 60. The primary form, Fig. 51, is a rhombohedron having angles of $104^{\circ}5'$ and $74^{\circ}5'$. The

second form of calcium carbonate is known as *aragonite*, having a specific gravity of from 2.92 to 3.28, and crystallizing in the form of rhombic prisms, Fig. 61. Another crystalline form often exhibited by aragonite is that of the penetration twins, shown in Fig. 62. A distinction between the two minerals was first drawn by Werner in 1788, and Haüy showed somewhat later that they crystallized in two distinctly different forms. For many years this difference was believed to be due to the presence of strontia in aragonite, and it was not until 1819, when Mitscherlich discovered the law of dimorphism, that it was satisfactorily explained.

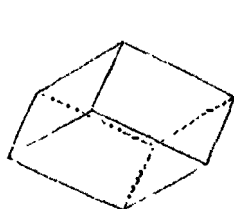

FIG. 51.



FIG. 52.



FIG. 53.

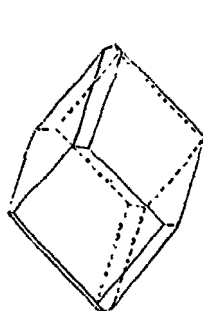

FIG. 54.

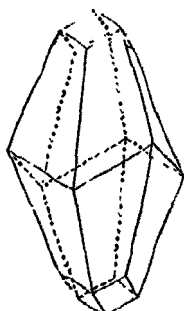

FIG. 55.



FIG. 56.

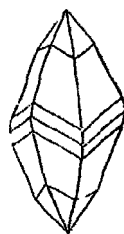
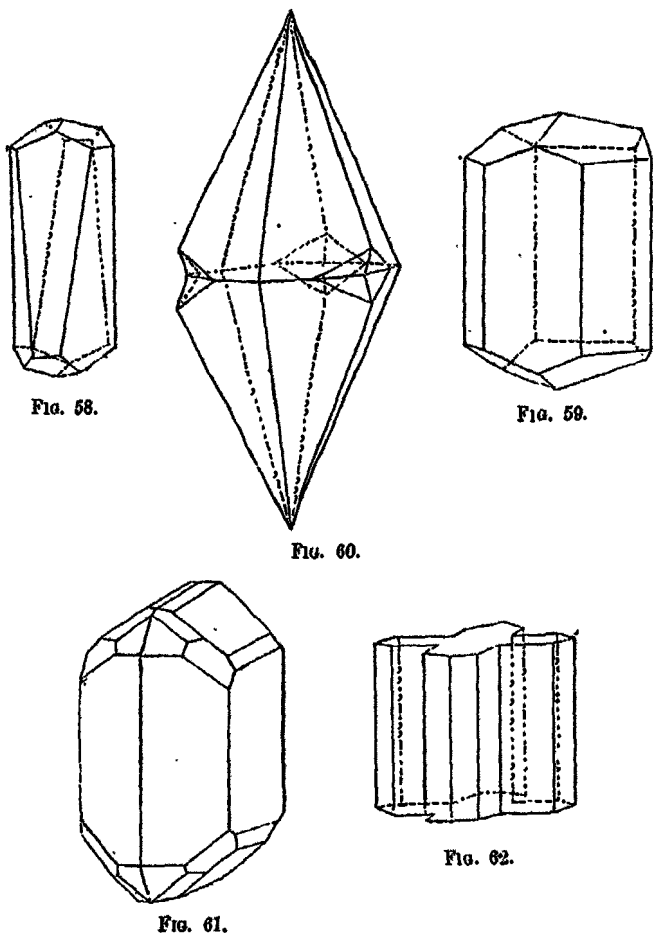

FIG. 57.

When a calcium salt is precipitated by the carbonate of an alkali-metal, or when carbon dioxide is passed through lime-water, the precipitate which falls down is at first flocculent and amorphous. That formed by passing a small quantity of carbon dioxide through cold lime-water soon becomes crystalline, the crystals being those of calc-spar, whilst aragonitic crystals are deposited when the lime-water is hot (G. Rose). Calc-spar crystals are deposited when a solution of calcium carbonate in

carbonic acid is allowed to evaporate spontaneously at the common temperature; but if the solution be heated to 90° arragonitic crystals separate out.

Calcium carbonate is not insoluble in water, 1 liter of either cold or boiling water dissolving about 18 milligrams. In presence



of free ammonia or carbonate of ammonia it is still less soluble. On the other hand, it readily dissolves in water containing carbonic acid in solution, and this fact was first noticed by Cavendish in 1767. One liter of water saturated with carbon dioxide

dissolves at 0° 0·70 gram of calcium carbonate, and at 10°, 0·88 gram. The solubility increases under an increase of pressure up to 3 grams per liter, but not beyond this point (Caro). If such a solution be allowed to stand at the ordinary temperature, six-sided prisms, having the composition $\text{CaCO}_3 + 5\text{H}_2\text{O}$, separate out. These crystals, which lose their water at 19°, are sometimes found in the pipes of pumps and also adhering to confervæ in ponds. When a solution of calcium carbonate in carbonic acid water is boiled, the liquid still contains in solution 34 milligrams of calcium carbonate per liter, and this solution does not render lime-water turbid.¹

MORTARS AND CEMENTS.

120 Ordinary mortar is a mixture of one part of lime made into a paste with water, and three or four parts of sharp sand. The completeness of the subsequent hardening of mortar depends upon the proper intermixture of the ingredients. Mortar, although it sets in a few days sufficiently to give stability to a structure, takes many years or even centuries to reach its maximum degree of hardness. It is difficult to explain the setting and subsequent slow hardening of mortar. The first process of setting appears simply to be due to the loss of water. Atmospheric carbon dioxide is then absorbed, and the calcium carbonate thus formed cements the sand and building material together. A slow combination was formerly supposed to occur between the lime and the silica of the sand. It has recently, however, been shown that this is not the case, the hardening of the mortar appearing to depend on the change of caustic lime into carbonate.²

Hydraulic Mortars. When limestone contains more than 10 per cent. of silica, the lime prepared from it yields a mortar which possesses the property of hardening under water, and is termed hydraulic mortar or Roman cement. Such lime can be prepared by mixing ordinary lime with a due proportion of clay, and carefully igniting the mixture. The original Roman cement was made by mixing lime with a volcanic tufa found at Puzzuoli, near Naples. The action of water upon the mixture of lime and clay was formerly supposed to cause the formation of a hydrated

¹ Hofmann, *Jahresbericht*, 1865.

² Spiller, *Chem. News*, xviii. 112.

silicate of lime and alumina, which being hard and insoluble in water, gives its peculiar property to the hydraulic mortar. This explanation, however, appears to be incorrect, for Schott has proved that Portland cement hardens better when moistened with a solution of ammonium carbonate than with pure water, pointing to the formation of calcium carbonate as the cause of the hardening.¹ If the clay present amounts to from 10 to 12 per cent. the mortar takes some weeks to harden, whereas if from 25 to 35 per cent. of clay be present, as in Roman cement, the mortar hardens in a few hours. Roman cement is largely prepared from the nodules of septaria, which are found in the valley of the Thames. *Portland Cement* is a hydraulic mortar, now very largely manufactured from chalk and the clay found in the valley of the Medway. The chalk and clay are thoroughly ground together with water and the finely divided mixture termed "slip," dried and carefully burnt in kilns. The following analyses of English (1 and 2) and German (3 and 4) Portland cements give the composition of this substance:—

	1.	2.	3.	4.
Lime ...	59·06	55·06	62·81	57·83
Silica ...	24·07	22·92	23·22	23·81
Alumina ...	6·92	8·00	5·27	9·38
Ferric oxide ...	3·41	5·46	2·00	5·22
Magnesia ...	0·82	0·77	1·14	1·35
Potash ...	0·73	1·13	1·27	0·59
Soda ...	0·87	1·70		0·71
Calcium sulphate	2·85	1·75	1·30	1·11
Clay ...	1·47	2·27	2·54	—
Sand ...				

CALCIUM AND SULPHUR.

121 *Calcium Monosulphide*, CaS, is obtained by heating the sulphate with powdered coal or by leading a mixture of carbon dioxide and the vapour of carbon disulphide over incandescent lime (Schöne). It forms a white mass insoluble in water, which in moist air smells of sulphuretted hydrogen. Calcium monosulphide is luminous in the dark after it has been exposed to light. This fact was noticed in the year 1750 by Marggraf, who obtained the sulphide by calcining gypsum with combustible

¹ *Dingl. Polyt. Journ.* cii. 434.

matter. In 1768, Canton described a method of producing the same effect by igniting calcined oyster-shells with sulphur; hence this substance was long known under the name of Canton's phosphorus.

Calcium Disulphide, CaS₂, is soluble in water, and is obtained in yellow crystals which contain 3 molecules of water when milk of lime is boiled with an excess of sulphur and the filtered solution allowed to cool.

122 Calcium Phosphide. When metallic calcium is heated under rock oil with phosphorus the two bodies combine. Calcium phosphide can also be obtained mixed with calcium pyrophosphate as a red, brown, or almost black mass, by passing the vapours of phosphorus over incandescent lime. The arrangement employed for this purpose is shown in Fig. 63. The crucible is filled with lime, and the phosphorus contained in the glass-flask is vaporized and passes through an opening at the bottom of the crucible on to the lime. This substance is employed for the preparation of liquid hydrogen phosphide as already described (Vol. I. p. 479).

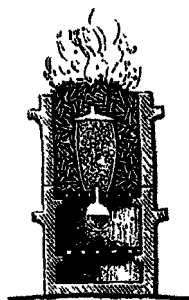

FIG. 63.

DETECTION AND ESTIMATION OF CALCIUM.

123 That certain calcium compounds impart a red colour to the flame of a spirit-lamp was first observed by Ribbentrop in 1796. The spectrum of a non-luminous gas flame tinted by calcium salt exhibits a large number of lines of which the green line Ca β is the most intense and characteristic. A second scarcely less characteristic line is the intensely orange line Ca α . The other green and orange lines as well as a line in the blue are much less intense. By means of the spectroscope so small a quantity as $\frac{1}{1000000}$ mgrm. of calcium chloride, or similar salt, may be detected. In order to detect calcium in compounds which do not volatilize in the flame, but which are decomposed by hydrochloric acid, it is only necessary to place a small quantity of the powdered mineral on the loop of a fine platinum wire, which loop has been previously dipped into dilute hydrochloric acid. The wire is then at once brought into the hottest part of the flame, where the drop

assumes the spheroidal state and gradually evaporates without boiling. At the moment when the last portion of the liquid evaporates, the flame becomes intensely coloured for a short time, and a bright calcium spectrum flashes out, lasting a longer or shorter time according to the amount of calcium present in the compound. Silicates of calcium which are not attacked by hydrochloric acid must be decomposed with a small quantity of ammonium fluoride, the mixture then heated to redness and the residue decomposed by dilute sulphuric acid and treated as above. The delicacy of the spectrum reaction for calcium is illustrated by the following experiments:—

(1) A drop of sea-water is volatilized on a platinum wire. This at first exhibits simply the bright sodium reaction, but, after the common salt has been volatilized, a weak calcium spectrum is seen, and this flashes out brightly if the wire be moistened with hydrochloric acid.

(2) If a drop of almost any mineral water such as that of Dürkheim or Baden-Baden be brought on the wire the lines $\text{Na } \alpha$ $\text{Li } \alpha$ $\text{Ca } \alpha$ and $\text{Ca } \beta$ are seen.

(3) If the ash of a cigar be moistened with a drop of hydrochloric acid and then held in the flame, the following lines are distinctly seen— $\text{Na } \alpha$, $\text{K } \alpha$, $\text{Li } \alpha$, $\text{Ca } \alpha$ and $\text{Ca } \beta$.

(4) A fragment of the difficultly fusible potash glass, such as a piece of combustion tube when brought into the flame alone, shows $\text{Na } \alpha$ and $\text{K } \alpha$; if treated with ammonium fluoride and sulphuric acid, the lines $\text{Ca } \alpha$ and $\text{Ca } \beta$ together with faint $\text{Li } \alpha$ are likewise seen.

Calcium may be separated from the alkali-metals by the addition of a solution of ammonium carbonate, calcium carbonate being precipitated. As has been stated, this latter salt is not altogether insoluble in water, and it is, therefore, preferable to precipitate the lime as calcium oxalate by the addition of ammonium oxalate in neutral or ammoniacal solution, this salt being completely insoluble in water. This reaction is usually employed for the determination of calcium; the washed and dried precipitate which has the composition $\text{Ca}_2\text{C}_2\text{O}_4 + 2\text{H}_2\text{O}$ is either gently ignited, by which means it is converted into the carbonate; or it is strongly ignited, when the carbonate is converted into caustic lime. Calcium is also occasionally determined as the sulphate. The precipitation by sulphuric acid must, however, be made in presence of alcohol, and the precipitate must also be washed with the same liquid.

The atomic weight of calcium was first accurately determined by Erdmann and Marchand,¹ by the ignition of calc-spar and of precipitated calcium carbonate. From their experiments it appears that when $O = 15.96$ and $C = 11.97$ the atomic weight of calcium is 39.88, 39.90, 39.93, or as a mean of the three numbers 39.9. Baup² obtained the number 39.87 as the result of the analysis of organic lime salts.

STRONTIUM, Sr = 87.2.

124 The name of the element is derived from that of Strontian, a village in Argyllshire, in which a peculiar mineral, strontium carbonate or stroutianite, was first found. At first this mineral was mistaken for barium carbonate, but in the year 1790 Crawford suggested that it contained a peculiar earth, founding his opinion upon experiments which had been made on the mineral by Cruikshank. This was confirmed in 1792 by Hope,³ and independently by Klaproth,⁴ a year afterwards. Sir Humphrey Davy in 1808 first obtained the metal strontium.

Strontium occurs chiefly as the sulphate or celestine $SrSO_4$, and as the carbonate or strontianite $SrCO_3$. Many specimens of arragonite and of calc-spar contain small quantities of strontium carbonate; and the same may be said of many kinds of limestone, marble and chalk, although the strontium is generally present only in very small traces. Baryto-celestine is a mineral which contains the sulphates of barium and strontium, and the latter compound occurs also in small quantities in different varieties of heavy spar. Strontium occurs as a silicate in brewsterite, $H_4(BaSr)Al_2Si_6O_{18} + 3H_2O$. Small quantities of the chloride and sulphate of strontium occur in solution in many brine-springs as well as in different mineral waters. It is also present in chalk waters, such as that of the London basin. Strontium has also been found in sea-water and in the ashes of *Fucus vesiculosus*.

Preparation of Metallic Strontium. Davy obtained the metal strontium by the electrolysis of either the moistened hydroxide or of chloride of strontium. It can be more readily prepared

¹ *Ann. Chem. Pharm.* lii. 210; lxxvi. 219.

² *Ann. Chem. Pharm.* lii. 212.

³ Account of a mineral from Strontian, *Trans. Roy. Soc. Edinb.* iv. 3.

⁴ *Urell. Ann.* 1793. ii. 189 and 1794 i. 99.

according to the method employed by Bunsen and Matthiessen.¹ A small porcelain crucible having a porous cell in the middle is filled with anhydrous chloride of strontium, mixed with a little sal-ammoniac, the level of the salt within the cell being considerably higher than in the crucible. The negative pole which is placed within the porous cell consists of a very thin iron wire, wound round a thicker one, and then covered with a piece of tobacco-pipe stem so that only $\frac{1}{8}$ th of an inch of it appears below; the positive pole is an iron cylinder placed in the crucible round the porous cell. The heat is regulated during the experiment so that a crust may form in the cell. The metal then collects under this crust without coming in contact with the oxygen of the air. By this method pieces of the metal weighing half a gram are sometimes obtained.

Metallic strontium can also be obtained, according to B. Franz,² by repeatedly heating a saturated solution of chloride of strontium with an amalgam of 250 grams of sodium and one kilogram of mercury to a temperature of 90°. The strontium amalgam thus obtained is quickly washed with water, and dried between folds of filter paper. It is then heated in a current of hydrogen in an iron crucible, by which means all the mercury is volatilized and a regulus of strontium remains behind.

Strontium is a yellow metal somewhat harder than calcium and lead. It may be hammered out into thin plates, and possesses a specific gravity of 2.5. It melts at a moderate red-heat, and is more electro-negative than calcium and the alkali-metals. It oxidizes quickly on exposure to the air, burns brilliantly when heated, and decomposes water violently.

STRONTIUM AND OXYGEN.

125 *Strontium Monoxide or Caustic Strontia*, SrO. This substance is obtained in the form of a greyish white porous infusible mass by the ignition of the nitrate. When brought into contact with a small quantity of water the monoxide unites with it to form a white powder of *strontium hydroxide*, Sr(OH)₂. This body possesses a specific gravity of 3.625, and when strongly heated is reconverted into strontia. The hydrate is easily soluble in hot water, and the solution, on cooling, deposits transparent

¹ *Quart. Journ. Chem. Soc.* viii. 107.

² *Journ. prakt. Chem.* cvii. 253.

quadratic crystals of the hydrate $\text{Sr}(\text{OH})_2 + 8\text{H}_2\text{O}$: 100 parts of cold water dissolve 2.0 and of boiling water 41.66 parts of the crystals. Strontia water has a strongly alkaline reaction and possesses caustic properties less marked than the solutions of the alkalis.

Strontium Dioxide, SrO_2 , is obtained in the form of a crystalline hydrate, $\text{SrO}_2 + 8\text{H}_2\text{O}$, by mixing a solution of the hydrate with hydrogen dioxide, when pearly scales of the hydrated dioxide are deposited. These lose water on heating, leaving the anhydrous dioxide as a light white powder which does not melt at a red-heat but gradually loses oxygen (Schöne).

SALTS OF STRONTIUM.

126 *Strontium Chloride*, SrCl_2 , is obtained by dissolving strontianite in hydrochloric acid. The hot concentrated solution deposits, on cooling, long hexagonal needles, $\text{SrCl}_2 + 6\text{H}_2\text{O}$, which are isomorphous with the corresponding hydrate of calcium chloride. They possess a sharp bitter taste, have a specific gravity of 1.603, and effloresce on exposure to the air. On heating, these crystals yield the anhydrous salt as a white powder, which melts at a high temperature to a white semi-transparent glassy mass having a specific gravity of 2.96. According to Mulder 100 parts of water dissolve:—

At	0°	20°	40°	60°	80°	100°	118°8
SrCl_2	44.2	53.9	66.7	83.1	92.4	101.9	116.4

Chloride of strontium dissolves in aqueous alcohol proportionally to the percentage of water which the alcohol contains. The commercial salt frequently contains calcium chloride, from which it may be purified by repeated crystallization from hot water.

Strontium Sulphate, SrSO_4 , is found in large well-developed rhombic crystals and as a fibrous amorphous mass. It generally possesses a light blue colour, whence it takes its name celestine (*caelestis*). When sulphuric acid or a soluble sulphate is added to a solution of a strontium salt, the sulphate is thrown down as a white precipitate possessing a specific gravity of 3.707 and fusing when strongly heated. It is but very slightly soluble in cold, and still less soluble in boiling water. One liter of water at the

ordinary temperature dissolves 0.145, and at the boiling-point 0.104 gram (Fresenius). Strontium sulphate is much more easily soluble in acids and in solution of common salt, as well as in other salt solutions, but less soluble in sulphates or dilute sulphuric acid. When boiled with a solution of the carbonate of an alkali, sulphate of strontium is completely decomposed. When the salt is dissolved in hot concentrated sulphuric acid, crystals of celestine separate out on cooling, and when it is treated with concentrated sulphuric acid at 100°, and the solution digested with an excess of salt at a somewhat higher temperature, the compound $H_2SO_4 + SrSO_4$ separates out as a granular crystalline powder, which when exposed to moist air changes into small glittering tables having the composition $H_2SO_4 + SrSO_4 + H_2O$.

Strontium Nitrate, $Sr(NO_2)_2$, is obtained by dissolving the carbonate in warm dilute nitric acid. When the solution is evaporated down, the anhydrous salt separates out in transparent octohedrons or in combinations of the octohedron and the cube. Strontium nitrate possesses a cooling taste. At 0°39 it has a specific gravity of 2.962 (Schröder), and when thrown on to red-hot charcoal it deflagrates, burning with a red flame. When a dilute solution is cooled down, the hydrate $Sr(NO_2)_2 + 4H_2O$ separates out in large well-developed monoclinic crystals which quickly effloresce on exposure to the air. One hundred parts of water dissolve, according to Mulder:

At	10°	20°	40°	60°	80°	100°	107°9
$Sr(NO_3)_2$	40.16	70.8	91.3	94.6	97.2	101.1	102.9

Strontium nitrate is insoluble in concentrated nitric acid and only very slightly soluble in absolute alcohol. Strontium nitrate is largely used for pyrotechnic purposes.

Strontium Carbonate, $SrCO_3$, occurs as strontianite in crystals which are isomorphous with those of arragonite. This compound is obtained in the form of a white impalpable powder having a specific gravity of 3.62, if a strontium salt be precipitated by an alkaline carbonate. When gently ignited it loses all its carbon dioxide and is converted into strontia. According to Fresenius 1 liter of water dissolves 55.4 mgrms. of this salt. It is less soluble in water containing ammonia, but dissolves considerably in a solution of sal-ammoniac and of ammonium nitrate. When boiled with sal-ammoniac it is converted into strontium chloride.

DETECTION AND ESTIMATION OF STRONTIUM.

127 Strontium salts colour the flame a magnificent crimson. The strontium spectrum consists of numerous bright lines of which 8 are specially characteristic, 6 in the red, 1 in the orange, and 1 in the blue. The orange line, termed Sr α , the red, Sr β , and Sr γ , and the blue line, Sr δ , are the most intense, and therefore the most valuable for the discrimination of this element. By means of spectrum analysis $\gamma\sigma\sigma.\sigma\sigma\sigma$ nigrin. of strontium chloride can be detected. H. Fox Talbot¹ was the first to describe the spectrum of strontium. He examined the spectrum of the red fire of theatres and distinguished many of the strontium lines especially the blue line, Sr δ . In February 1834, Talbot writes, "the strontia flame exhibits a great number of red rays well separated from each other by dark intervals, not to mention an orange, and a very definite bright blue ray. The lithia exhibits one single red ray." In order to detect strontium the bead either alone or moistened with hydrochloric acid is brought into the flame. If strontium is supposed to be present as sulphate the bead is held for a few moments in the reducing portion of the flame and then moistened with hydrochloric acid in order to convert the strontium sulphide, which is formed into strontium chloride. The strontium salts containing non-volatile acids are melted on a platinum wire with a small quantity of sodium carbonate. The fused bead is then reduced to a fine powder and dissolved in a little hot water, and the residue which contains carbonate of strontia moistened with hydrochloric acid, and the chloride brought on a wire into the non-luminous flame.

Strontium is separated from the alkali-metals by precipitation with ammonium carbonate. If calcium be present at the same time the strontium may be detected by adding a solution of gypsum to the hydrochloric acid solution of the carbonate. If strontium be present the solution will become turbid after standing for a short time. Strontium is usually determined quantitatively as the sulphate by precipitating the solution with sulphuric acid in the presence of alcohol and washing the precipitate with a weaker alcohol. In order to separate it from calcium the substances are converted into nitrates and these treated with absolute alcohol which leaves the nitrate of strontium undissolved.

¹ Brewster's Journ. of Science, v. (1826).

The atomic weight of strontium was determined by Marignac, who found that 100 parts of the pure crystallized chloride, $\text{SrCl}_2 + 6 \text{H}_2\text{O}$, required 80.998 parts of silver for complete precipitation, and that the same quantity yielded 68.855 parts of strontium sulphate.¹

BARIUM, Ba = 136.8.

128 Our knowledge of the barium compounds commences with that of the natural sulphate or heavy-spar. This substance was first examined in the year 1602, by a Bolognese shoemaker, V. Casciorolus, who noticed that it possessed the remarkable property of becoming phosphorescent when ignited with combustible matter. To this material the discoverer gave the name of *lapis solis*, but it became better known as Bolognian or Bononian phosphorus, from the place in which it was first prepared, whence specimens of the shoemaker's handiwork found their way into the laboratories of the alchemists of the time. The mineral which yielded this phosphorus, termed Bolognian spar, was first believed to be a peculiar kind of gypsum, and hence it was termed *gypsum spathosum*. In consequence of its high specific gravity, Cronstedt termed it *marmor metallicum*, and Marggraf in 1750, finding that it contained sulphuric acid, ranked it amongst what were then termed the heavy fluor-spars. The nature of this mineral remained for some time obscure, and the learned mineralogist v. Justi writes in 1760 concerning it as follows: "Our analysis has here reached its limits; we know of no smelting operation by which anything can be got out of this spar. Many profound chemists and skilful assayers have here tried their art in vain." The next step in our knowledge of this subject was made in the year 1774, when Scheele, engaged in his investigation on the black oxide of manganese, examined a specimen of this mineral which he found to contain a new earth, and this when brought in contact with sulphuric acid yielded a salt insoluble in water, which could be brought into a soluble condition by ignition with carbon and an alkali. Gahn afterwards showed that this earth is contained in heavy-spar, and Bergmann gave it the name *terra ponderosa*. Guyton de Morveau in 1779 proposed the name barote (from *βαρύς*, heavy), and this name,

¹ *Ann. Chem. Pharm.* cvi. 165.

slightly altered to baryta by Lavoisier, was soon generally adopted. The suggestion that this earth is the oxide of a metal was frequently made, but the fact was not proved until after Davy's discovery of the decomposition of the alkalis.

Barium occurs in nature chiefly as the sulphate or heavy-spar, BaSO_4 , which is often found together with galena and other metallic ores, though also found not associated with metallic veins. Another source of barium compounds, less widely distributed, is the carbonate or witherite, BaCO_3 , whilst other minerals containing barium are barytocelestite, $(\text{BaSrCa})\text{SO}_4$, barytocalcite, $\text{BaCO}_3 + \text{CaCO}_3$, alstonite, $(\text{BaCa})\text{SO}_4$, psilomelane $(\text{MnBa})\text{O} + \text{MnO}_2$. Many other ores of manganese, especially manganese dioxide, contain small quantities of barium. Barium also occurs as an essential constituent of certain silicates; thus, for instance, brewsterite, $\cdot\text{H}_4(\text{SrBa})\text{Al}_2\text{Si}_6\text{O}_{18} + 3\text{H}_2\text{O}$, harmotome, $\text{H}_2(\text{K}_2\text{Ba})\text{Al}_2\text{Si}_6\text{O}_{18} + 4\text{H}_2\text{O}$ and hyalophane or baryta-felspar, $\text{K}_2\text{Ba}_2\text{Al}_2\text{Si}_8\text{O}_{24}$. Many other feldspathic rocks also contain traces of barium, and this element occurs likewise in several other minerals. Traces are found in mineral waters and in sea-water. Thus, for instance, the old sulphur well at Harrogate contains 6.6 grains of barium chloride per gallon (Hayton Davis).¹ From sea-water, barium finds its way into sea-plants, and in smaller quantities into the shells and skeletons of sea-animals.

Preparation of Metallic Barium. Davy's first attempts to obtain metallic barium were not very successful. He endeavoured first to obtain it by the electrolysis of baryta. Afterwards finding that this did not succeed he prepared it from an amalgam, having heard from Berzelius that he and Pontin had succeeded in obtaining it in that way. Davy repeated these experiments and electrolysed baryta, barium chloride, and other barium salts in presence of mercury, heating the amalgam which was thus formed in a tube containing rock oil, when the barium was left behind as a silver-white powder. According to Bunsen's process² the metal may be obtained by electrolysing a thick mixture of very dilute hydrochloric acid and barium chloride at a temperature of 100° in presence of mercury. In this way a crystalline barium amalgam may be obtained, which, on heating, leaves metallic barium behind in the form of a tarnished porous mass, the cavities of which sometimes exhibit a silver-white surface. The experiment is however more successful when a galvanic

¹ Thorpe, *Phil. Mag.* [5], ii. 52.

² *Pogg. Ann.* xci. 619.

current is passed through barium chloride in a state of fusion, the negative pole consisting of a fine harpsichord wire on which the barium is deposited in the form of small globules. It oxidizes very quickly, and burns brilliantly when heated in the air.¹

The melting-point of barium appears to be higher than that of cast-iron (Frey).

BARIUM AND OXYGEN.

129 *Barium Monoxide or Baryta*, BaO, is formed when the metal burns in the air, but is usually obtained by heating the nitrate in an iron crucible, until no further evolution of red fumes is observed. The mass fuses and is apt to froth over unless care is taken. Mohr has proposed to mix the nitrate with its own weight of sulphate of barium; this prevents the frothing, and for many purposes the presence of insoluble barium sulphate does not matter. If only a small quantity of baryta is required it is best obtained by igniting the iodate which gives off its iodine and five-sixths of its oxygen without fusing or frothing:



Baryta forms a greyish-white porous mass which has a specific gravity of 4.73 (Carston) and melts at a white heat. When moistened with water it slakes with evolution of so much heat, that if it is only sprinkled with water it becomes incandescent.

Barium Hydroxide, Ba(OH)₂ is formed as a white powder by the reaction just described. The hydroxide melts at a low red heat, forming an oily liquid, which on cooling solidifies to a crystalline mass, and this does not give off water even when more strongly heated. It has a specific gravity of 4.495 (Filhol), and when brought in contact with water forms a crystalline hydrate, Ba(OH)₂ + 8H₂O. This hydrate is soluble, and on cooling a saturated solution it separates out in quadratic prisms which are isomorphous with strontium hydrate. On exposure to air these crystals fall to a white powder with loss of seven molecules of water. One hundred parts of water dissolve:

At	0°	20°	40°	60°	80°
BaO	1.5	3.5	7.4	18.8	90.8 parts.

¹ Matthiessen, *Ann. Chem. Pharm.* xciii. 277.

A solution of the hydroxide is termed *baryta-water*, and is largely used in the processes of chemical analysis. It has a more strongly alkaline reaction than lime-water, and rapidly absorbs carbon dioxide. It is employed, as has been stated in Vol. I., p. 451, for the determination of the carbonic acid contained in the atmosphere. It must for this purpose be free from alkali. In order to ascertain this, a given volume must be exactly precipitated with a standard oxalic acid solution. To an equal volume a little pure precipitated barium carbonate is then added, and the liquid treated again with the standard oxalic acid. In the absence of an alkali the same volume of the standard solution will in both cases be required for complete neutralization; but if an alkali be present more oxalic acid will be required in the second case, inasmuch as an alkaline oxalate is then first formed, and this in contact with the carbonate yields an alkaline carbonate and barium oxalate, the decomposition going on until all the barium carbonate is converted into oxalate.

Caustic baryta is prepared on the large scale from barium sulphide. This is heated in earthenware retorts, into which a current of moist carbonic acid is passed. Superheated steam is then passed over the carbonate, when the following decomposition takes place:

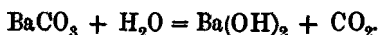

Caustic baryta is now employed in the processes of sugar-refining, instead of lime, as baryta forms an insoluble compound, $\text{C}_{12}\text{H}_{22}\text{O}_{11}\text{BaO}$, with cane sugar, whilst lime forms a soluble compound with sugar but precipitates the acids and nitrogenous substances from the juice. The barium-sugar compound is easily decomposed by suspending it in water and subjecting it to the action of carbonic acid gas, when the sugar dissolves, and insoluble barium carbonate is precipitated.

Barium Dioxide, BaO_2 . When heated to redness in a current of dry oxygen, pure baryta absorbs the gas with rapidity, forming the dioxide (Gay-Lussac and Thénard). The hydroxide when heated to redness in a current of air also yields the dioxide (Boussingault). The product thus obtained is a greyish porous mass somewhat more fusible than baryta, which when heated to a bright-red heat fuses with loss of one atom of oxygen. It combines with water to form the hydrate $\text{BaO}_2 + 8\text{H}_2\text{O}$. In order to prepare this substance in the pure state

from the crude peroxide which usually contains silica, lime, and iron oxide from the iron vessels in which it is prepared, it is treated as follows. The finely powdered substance is thrown little by little into dilute hydrochloric acid until this is nearly neutralized. The solution on cooling is filtered, and baryta water is gradually added to this, until the silica and the metallic oxides which it contains are thrown down, and a small quantity of the hydrate is likewise precipitated. The liquid is then filtered and concentrated baryta-water is added to the filtrate so long as a crystalline precipitate is formed. This is then filtered off and washed with cold water.¹ The hydrated dioxide can be kept in the moist state in closed vessels without undergoing decomposition, and it is employed for the preparation of hydrogen dioxide.

When dried at 130°, barium dioxide is obtained as a white impalpable powder scarcely to be distinguished from magnesia. The pure compound is also easily obtained by heating a mixture of caustic baryta and potassium chlorate in a crucible to low redness (Liebig and Wöhler). The mass is then dissolved in water and treated as above described (Brodie). In order to obtain barium dioxide on the large scale, Tessié de Motay and Maréchal have proposed to heat a mixture of barium carbonate and carbon in a reverberatory furnace when baryta and carbon dioxide are formed :

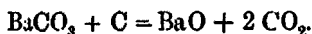

Oxygen is then allowed to pass at a high temperature over the baryta, the carbon burning away and barium dioxide being formed. Atmospheric air cannot be used instead of oxygen, as the nitrogen combines to form barium cyanide.

SALTS OF BARIUM

130 *Barium Chloride*, BaCl_2 , is most readily obtained by dissolving witherite in dilute hydrochloric acid. As, however, this mineral contains calcium, lead, iron, and manganese compounds, an excess of barium carbonate is added to the solution and the liquid allowed to remain in contact with it for some time. In this way the oxides of the above metals are precipitated and the rapidity of the precipitation can be increased by the addition

¹ Thomsen, *Ber. Deutsch Chem Ges.* vii. 73.

of a small quantity of baryta-water. The clear solution is then neutralized with hydrochloric acid and evaporated to the point of crystallization. On the large scale the salt is easily prepared from heavy-spar. For this purpose 100 parts of the finely powdered mineral are mixed with from 35 to 50 parts of carbon, from 15 to 25 parts of limestone and from 40 to 60 parts of calcium chloride. This mixture is heated in a reverberatory furnace and the mass lixiviated with water when insoluble calcium sulphide remains behind and the barium dissolves as chloride. Chloride of barium can also be prepared by means of the manganese chloride which remains as a by-product in the manufacture of chlorine. For this purpose the chlorine residues are neutralized with chalk, evaporated down and heated to redness on a cast-iron plate with a mixture of heavy-spar and silica. The mass which contains barium chloride, manganese sulphide and a small quantity of sulphide of iron, is lixiviated with warm water. Should the solution contain any sulphide of barium, which may be seen by the yellow colour of the solution, a small quantity of manganese chloride may be added, and *vice versa* should any of the latter salt remain in excess it is only necessary to add a sufficient quantity of barium sulphide.



FIG. 64.

Barium chloride crystallizes from solution with two molecules of water, $\text{BaCl}_2 + 2\text{H}_2\text{O}$. This forms colourless rhombic tables (Fig. 64), which do not undergo any alteration in the air and have a specific gravity of 3.05. 100 parts of water dissolve :

At	10°	20°	30°	40°	50°	60°	70°	80°	90°	100°	104°
BaCl_2	33.3	35.7	38.2	40.8	43.6	46.4	49.4	52.4	55.6	58.8	60.3

Barium chloride is less soluble in dilute hydrochloric acid than it is in water. It is almost insoluble in the concentrated acid ; it is also but slightly soluble in strong nitric acid and for this reason these acids precipitate concentrated solutions of a barium salt. Absolute as well as strong alcohol does not dissolve barium chloride but dilute alcohol dissolves a small quantity, and this increases in proportion to the amount of water present.

Crystallized barium chloride loses its water at a temperature of 113° forming a white powder which melts at a red-heat and on cooling solidifies to a translucent mass. On exposure to the air the chloride in a state of fusion parts with a small quantity of

chlorine, baryta being formed. Hence the fused salt usually has an alkaline reaction. When heated in a current of steam it emits hydrochloric acid at a temperature below its fusing point. Barium chloride has an unpleasant bitter taste and acts as a powerful poison. The chief use of barium chloride is for the preparation of the artificial sulphate or *permanent white*. It has also been successfully employed for the prevention of incrustation in steam boilers when permanently hard waters are used. All the gypsum contained in solution is decomposed by barium chloride, whilst any calcium carbonate present in solution may be subsequently precipitated by milk of lime. The water thus softened forms no incrustation.

Barium Chlorate, $\text{Ba}(\text{ClO}_3)_2$, is obtained by saturating aqueous chloric acid with carbonate of barium. The salt is easily soluble in water and crystallizes in monoclinic prisms. It is also slightly soluble in alcohol and the alcoholic solution burns with a characteristic green flame. If a drop of sulphuric acid is brought on to a mixture of the salt and powdered sugar the mixture takes fire and burns with a bright green flame. If barium chlorate in a state of fusion and very strongly heated be plunged into an atmosphere of coal-gas combustion also takes place, the oxygen of the chlorate being in this case the burning body and the carbon and hydrogen of the coal-gas the supporters of combustion.

Barium Iodate, $\text{Ba}(\text{IO}_3)_2$. This salt is employed for the preparation of iodic acid. It is obtained as a white granular precipitate by adding potassium iodate to barium chloride (Vol. I. p. 281). The barium iodate dissolves in 3,000 parts of cold and 600 parts of boiling water. It dissolves in hot nitric acid from which solution it crystallizes, on cooling, in bright glittering monoclinic prisms which are isomorphous with the chlorate. It dissolves in hydrochloric acid with evolution of chlorine.

131 *Barium Sulphate*, BaSO_4 , is by far the commonest and most widely distributed of the barium compounds, and occurs as heavy-spar, which crystallizes in the rhombic system, Figs. 65 to 67.

If anhydrous baryta be brought into contact with fuming sulphuric acid, or even with sulphuric acid which contains a small quantity of water, combination takes place with such force that the mass becomes incandescent. On the other hand, pure sulphuric acid which has the exact composition

H_2SO_4 does not act upon baryta. But if the mixture be touched in one place with a hot iron or with a moistened glass-rod, combination begins and is at once propagated throughout the mass (Kuhlman). Sulphuric acid and its salts precipitate the sulphate from a solution of a soluble barium salt in the form of a crystalline powder. The pure mineral heavy-spar has a specific gravity of 4.486 (H. Rose), the precipitated salt at 4° having a specific gravity of 4.53 (Schröder). This salt is almost perfectly insoluble in water as one part requires 400,000 parts of water to dissolve it. It is somewhat more soluble in dilute acids. If a salt of barium be heated with concentrated sulphuric acid, the sulphate dissolves to a certain extent and separates out on cooling in crystals having the composition $\text{H}_2\text{SO}_4 + \text{BaSO}_4$. If this acid solution be exposed

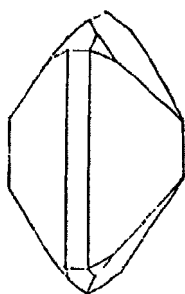

FIG. 65.

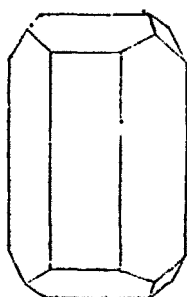

FIG. 66.

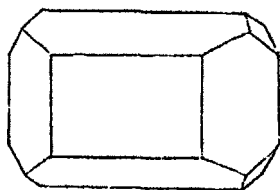

FIG. 67.

to moist air bright silky needles are formed having the composition $\text{H}_2\text{SO}_4 + \text{BaSO}_4 + 2 \text{H}_2\text{O}$.

Finely ground colourless heavy-spar mixed with more or less white lead is largely used as a paint. Artificial barium sulphate is also manufactured on a large scale and is known as *permanent white* or *blanc fixe*. This preparation is largely used as a pigment and is much to be preferred for this purpose to the finely ground mineral; inasmuch as the latter, with its crystalline structure, is transparent and has but little "body" or covering power. In order to prevent the formation of finely divided crystals a solution of barium chloride having a specific gravity of 1.19 is precipitated in the cold with dilute sulphuric acid having a specific gravity of 1.245. The precipitate is washed with cold water and sent to market in the moist state. In

addition to its value as a paint, blanc fixe is largely used for giving weight to cards and paper.

Barium Disulphate, BaS_2O_7 . If powdered barium sulphate be intimately mixed with fuming sulphuric acid it dissolves, forming a syrup which on heating to 150° deposits the disulphate in glistening granular crystals which do not melt on heating and decompose at a dull red-heat.

Barium Dithionate, $BaS_2O_6 + 2H_2O$. This salt is prepared by decomposing the corresponding manganese salt with barium sulphide. On allowing the solution to evaporate in a warm place glittering rhombic crystals of the salt are deposited. It dissolves at 18° in 4.04, and at 100° in 1.1 parts of water. On heating it is converted without change of form into barium sulphate.

Barium Nitrate, $Ba(NO_3)_2$. This salt is prepared on the large scale either by decomposing the carbonate or sulphide by dilute nitric acid, or by mixing hot saturated solutions of sodium nitrate and barium chloride. In cooling, the larger portion of the nitrate of barium crystallizes out, and the remaining portion is obtained by evaporating the mother liquors. Barium nitrate crystallizes in cubo-octahedrons, and in other more complicated forms of the regular system (Lewis). Its specific gravity is 3.2; it possesses an acrid taste and melts at a temperature of 597° (Carnelley). 100 parts of water dissolve at

	0°	10°	20°	30°	40°	50°
$Ba(NO_3)_2$	5.2	7.0	9.2	11.6	14.2	17.1
	60°	70°	80°	90°	100°	102°
$Ba(NO_3)_2$	20.3	23.6	27.0	30.6	32.2	34.8

The salt is insoluble in concentrated nitric acid and in absolute alcohol and dissolves only sparingly in these liquids diluted with water. Barium nitrate is largely used for pyrotechnic purposes, especially for the preparation of green fire, and for the manufacture of an explosive powder known as *saxifragin*, which consists of a mixture of 76 parts of nitrate of barium, 22 parts of carbon, and 2 parts of nitre.

Silicates of Barium. It has been already stated that many of these salts occur as crystalline minerals. Barium silicate is also a constituent of baryta-glass, a flint-glass in which the lead has been replaced by barium. This will be described under Glass Manufacture.

Barium Silico-fluoride, BaSiF_6 . This compound is precipitated in the form of small hard crystals, when hydrofluosilicic acid is added to a solution of a barium salt; it dissolves in 3,800 parts of water and is somewhat more soluble in hydrochloric acid and hot water, but is nearly insoluble in alcohol.

Barium Carbonate, BaCO_3 . Barium carbonate occurs in nature as witherite. This mineral was discovered at Leadhills in Scotland by Withering in the year 1783. It crystallizes in rhombic prisms and pyramids, is isomorphous with arragonite, and is chiefly found in England, one of its most celebrated localities being Fallowfield in Northumberland. It also occurs in Silesia, Hungary, Styria, Russia, Chili, and other places. Alstonite $(\text{BaCa})\text{CO}_3$ is isomorphous with witherite, and contains the two metals in varying proportions. Baryto-calcite, on the other hand, has the formulæ $\text{BaCO}_3 + \text{CaCO}_3$, and crystallizes in the monoclinic system.¹

Artificial barium carbonate is a dense white powder obtained when a solution of chloride of barium is poured into an excess of a hot solution of ammonium carbonate. One part of the salt dissolves in 14,000 parts of water at the ordinary temperature and in 15,400 parts of boiling water (Fresenius).

The salt thus artificially prepared is used in chemical analysis, and powdered witherite is employed for the preparation of the other barium salts and as a rat-bane.

BARIUM AND SULPHUR.

132 *Barium Monosulphide*, BaS , is obtained when sulphuretted hydrogen is passed over heated baryta as long as water is formed. On the large scale it is prepared by roasting 20 parts of slack with 100 parts of heavy-spar. In order to assist the evolution of the carbon dioxide sawdust may be added to the mixture. Another proposal is to heat the heavy-spar with the asphalt of tar-works, the hydrogen which is contained in this material preventing the formation of polysulphides of barium (Lenoir).

Pure barium sulphidè is a white powder which decomposes in contact with water into barium hydroxide and barium hydro-sulphide :



¹ Groth, *Uebersicht der Mineralien*.

When a solution of 5 parts of the sulphide is boiled with 1 part of sulphur and the solution is allowed to evaporate in a vacuum, colourless transparent six-sided tables of $\text{BaS} + 6\text{H}_2\text{O}$ are deposited. When these crystals are treated with a small quantity of water, barium hydrosulphide dissolves and barium hydroxide remains behind.

Barium Hydrosulphide, $\text{Ba}(\text{SH})_2$, is obtained in the pure state by saturating baryta water, or a solution of barium sulphide with sulphuretted hydrogen. It crystallizes in transparent colourless prisms and is insoluble in alcohol.

Barium Trisulphide, BaS_3 , is formed when 2 parts of barium sulphide are fused together with 1 part of sulphur, the excess of sulphur being distilled off at a temperature below 360° . It is a greenish-yellow mass which yields a yellow powder. At 400° it melts, with loss of sulphur, forming a dark black liquid. On boiling it for some time with water it dissolves, forming a red liquid which on cooling deposits hydrated crystals of barium monosulphide and barium tetrasulphide.

Barium Tetrasulphide, $\text{BaS}_4 + \text{H}_2\text{O}$. When an aqueous solution of 7 parts of barium sulphide is boiled for some time with 4 parts of sulphur, pale red rhombic prisms are deposited which appear yellow by transmitted light and become of a lighter tint on standing. It is easily soluble in water, yielding a deep red-coloured liquid, from which it is precipitated in the form of an orange yellow crystalline powder on the addition of alcohol.

Barium Pentasulphide, BaS_5 . When an aqueous solution of the monosulphide is boiled with sulphur, a bitter alkaline caustic yellow solution is obtained and on evaporation this yields crystals of barium tetrasulphide and sulphur :



Bononian Phosphorus. The Bononian phosphorus which has been already mentioned is best prepared by heating 5 parts of precipitated barium sulphate together with 1 part of powdered charcoal over an ordinary gas flame for 30 minutes, and then igniting it more strongly over a gas blowpipe for ten minutes. Whilst hot the mass must be filled into glass tubes and the tubes sealed. After exposure to sunlight or to the light of burning magnesium wire this mass phosphoresces in the dark with a bright orange-coloured light. Strontium sulphate treated in the same way yields a mass which emits a faint yellowish green light. If, however, the sulphide of strontium be ignited in a

current of hydrogen gas a body is obtained which phosphoresces with a green, blue, violet, or red light. If on the other hand the carbonate of strontium be ignited with sulphur a mass is obtained which gives a blue or emerald green fluorescence. In this respect calcium salts do not act so satisfactorily as those of barium and strontium.¹ According to Thomson² an addition of 2 per cent. of manganese dioxide to calcium sulphide changes the phosphorescence from green to orange. Tubes containing these various phosphorescent powders can now be bought in Paris.

DETECTION AND ESTIMATION OF BARIUM.

133 The non-luminous gas-flame is coloured a yellowish green tint when any volatile barium compound is brought into it. The barium compounds yield the most complicated of the spectra of the alkalis and alkaline earths. It is, however, at once distinguished by the green lines Ba α and Ba β which are by far the most distinct, appearing the first and continuing during the whole of the reaction. Bay is not nearly so distinct, but is still a well-marked and peculiar line. As the barium spectrum is more extended than the spectra of the other metals, the reaction is not observed with so great a degree of delicacy, but it appears from Bunsen's experiments that about $\frac{1}{1000}$ of a milligram of barium salt may be detected with the greatest certainty. The chloride, bromide, iodide, and fluoride of barium, as well as the hydrated oxide, the sulphate, and carbonate, show the reaction best. It may be obtained by simply heating any of these salts in the flame. Silicates containing barium which are decomposed by hydrochloric acid give the reaction, if a drop of hydrochloric acid be added to them before they are brought into the flame. Baryta-harmotome, treated in this way, gives the lines Ca α and Ca β , together with the bands Ba α and Ba β . Compounds of barium with fixed acids, giving no reaction either when alone or after addition of hydrochloric acid, should be fused with carbonate of sodium as described under strontium, and the carbonate of barium thus obtained examined. If barium and strontium occur in small quantities together with large amounts of calcium, the carbonates obtained by fusion are dissolved in nitric acid and the dry salt extracted with alcohol; the residue contains only barium and strontium, both of which can

¹ Forster, *Pogg. Ann.* cxxxiii. 94 and 228.

² *Proc. Manchester Lit. and Phil. Soc.*, (1877) 86.

almost always be detected. When we wish to test for small traces of strontium or barium, the residual nitrates are converted into chlorides by ignition with sal-ammoniac, and the chloride of strontium is extracted by alcohol. Unless one or more of the bodies to be detected is present in very small quantities, the methods of separation just described are quite unnecessary, as is seen from the following experiment:—A mixture of the chlorides of potassium, sodium, lithium, calcium, strontium, and barium, containing at the most $\frac{1}{10}$ of a milligram of each of these salts, was brought into the flame, and the spectra produced were observed. At first the bright yellow sodium line, $\text{Na } \alpha$, appeared with a background formed by a nearly continuous pale spectrum; as soon as this line began to fade, the exactly defined red line of lithium, $\text{Li } \alpha$, was seen, and still further removed from the sodium line the faint red potassium line, $\text{K } \alpha$, was noticed; whilst the two barium lines, $\text{Ba } \alpha$, $\text{Ba } \beta$, with their peculiar form, became visible in the proper position. As the potassium, sodium, lithium, and barium salts volatilized their spectra became fainter and fainter, and their peculiar bands one after the other vanished, until, after the lapse of a few minutes, the lines $\text{Ca } \alpha$, $\text{Ca } \beta$, $\text{Sr } \alpha$, $\text{Sr } \beta$, $\text{Sr } \gamma$, and $\text{Sr } \delta$ became gradually visible, and, like a dissolving view, at last attained their characteristic distinctness, colouring, and position, and then, after some time, became pale, and disappeared entirely. The absence of any or of several of these bodies is at once indicated by the non-appearance of the corresponding bright lines.

Soluble barium salts are distinguished from those of strontium and calcium, inasmuch as they are at once precipitated by a solution of calcium sulphate. For the purpose of separating barium from the other two metals, hydrofluosilicic acid may be employed, which precipitates barium as an insoluble silicofluoride. If the sulphates of the three metals are boiled with a solution of one part of carbonate of potassium and three parts of potassium sulphate, or if they are treated in the cold with a concentrated solution of ammonium carbonate for twelve hours, the carbonates of strontium and calcium are formed, and these may be removed by washing with hydrochloric acid, whilst the barium sulphate remains unaltered.

Barium is almost always estimated quantitatively as the sulphate, and in some special cases as the carbonate.

The determination of the atomic weight of barium has been

made the subject of experiment by several chemists. The experiments of Marignac are especially accurate. 100 parts of crystallized chloride of barium precipitated 88.4067 parts of silver, whence the atomic weight 136.84 is obtained. From 100 parts of the same salt he obtained 95.43 parts of barium sulphate, and these numbers confirm the first result.¹

METALS OF THE MAGNESIUM GROUP.

Beryllium.	Zinc.
Magnesium.	Cadmium.

134 These metals decompose water only at a high temperature. They are volatile and burn with bright flame when heated in the air. Each metal forms only one oxide and one sulphide. With the exception of the slightly soluble magnesium oxide, the oxides are insoluble in water. The sulphates of this group of metals are soluble, the normal carbonates and phosphates insoluble, in water.

BERYLLIUM OR GLUCINUM, Be = 9.

Vauquelin in 1798 was the first to detect the existence of the oxide of this metal in beryl, this mineral having formerly been regarded as a compound of silica, with lime or alumina. The earth contained in beryl was shown by Vauquelin to be a distinct body, differing from both lime and alumina, inasmuch as it forms a soluble sulphate which is incapable of uniting with potassium sulphate to form an alum. Haiiy had previously observed that emerald is mineralogically identical with beryl, and on examining the former mineral Vauquelin found that it likewise contained the new earth. He did not give any special name to this new earth, but the editors of the *Annales de Chimie* gave it the name of glucina from *γλυκύς* sweet, because its salts possess a peculiar sweet taste. As, however, there are other salts which possess the same property, the name beryllia, derived from the mineral, was given to it by the German chemists.

¹ *Ann. Chem. Pharm.* cvi. 165.

Beryllium occurs in many minerals, especially in beryl, $\text{Be}_3\text{Al}_2\text{Si}_6\text{O}_{18} = 3 \text{BeO}, \text{Al}_2\text{O}_3, 6\text{SiO}_2$. Beryl crystallizes in hexagonal prisms, Figs. 67, 68, and 69, which usually have a green colour, colourless beryl being seldom met with. The transparent green-coloured varieties of beryl are known as emerald, those possessing a bluish-green tint being termed aquamarine. Beryl occurs also of a blue, yellow, grey, and rose-red tint. When the mineral is transparent it is termed precious beryl; when translucent or opaque it is known as common beryl. Beryllium also occurs in phenacite, Be_2SiO_4 ; euclase, $\text{H}_2\text{Be}_2\text{Al}_2\text{Si}_2\text{O}_{10} = \text{H}_2\text{O}, 2\text{BeO}, \text{Al}_2\text{O}_3, 2\text{SiO}_2$; and chrysoberyl, $\text{BeO}, \text{Al}_2\text{O}_3$, as well as in other minerals.

Metallic Beryllium was first obtained by Wöhler in the year 1828 by fusing the chloride with potassium. Obtained in this way

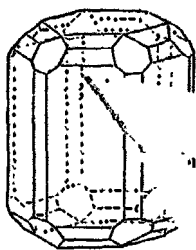

FIG. 68.

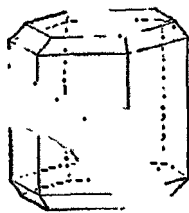

FIG. 69.

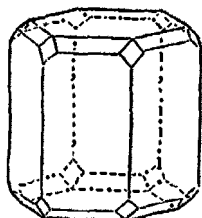

FIG. 70.

beryllium is a dark grey powder, which, under the burnisher, assumes a bright metallic lustre.¹ Debray,² however, first obtained this metal by bringing together the vapours of chloride of beryllium and sodium in a current of hydrogen. For this purpose a glass tube is employed into which a small boat, made of a mixture of clay and lime and containing metallic sodium, is brought, and after it a similar boat containing chloride of beryllium. As soon as the air has been entirely displaced by dry hydrogen, the sodium and the chloride of beryllium are both gently heated, and the vapour of the chloride is thus carried over the sodium. A violent reaction occurs, and the chloride is reduced to metal. In order to obtain the metal in the coherent state the powder or mass of small globules of metal thus obtained is again fused in a crucible under chloride of sodium. The specific gravity of the metal is

¹ *Pogg. Ann.* xiii. 577.² *Ann. Chim. Phys.* [3] xlv. 5.

2:1; it possesses a bright silver-white colour, melts at a lower temperature than silver, and when heated before the blow-pipe becomes covered with a film of oxide which prevents further oxidation. In the finely powdered state, on the other hand, it takes fire when heated in the air and burns with great brilliancy. The powdered metal dissolves in dilute acids: the compact form is readily soluble in dilute hydrochloric acid, but dilute sulphuric acid dissolves it only when warm, whilst concentrated nitric acid does not attack it in the cold, and on heating does so only slowly. The metal does not decompose water even at a red heat (Debray). Ammonia does not act either upon the powder or on the compact metal, but both forms dissolve readily in caustic potash with evolution of hydrogen.

135 *Beryllium Oxide* or *Beryllia*, BeO . Several methods may be employed for the preparation of this earth from beryl. The powdered mineral may be fused with three parts of potassium fluoride and the fused mass afterwards treated with sulphuric acid, or it may be fused with twice its weight of potassium carbonate and concentrated sulphuric acid, the latter method being preferred until the silica which separates out is rendered insoluble. The solid is then treated with water, and the solution evaporated until a crust is formed, from which the liquid is set aside to crystallize. After standing, the mother-liquor is poured off from the alum which has separated out, again concentrated, and then allowed to crystallize, and thus almost the whole of the alumina can be crystallized out as alum. The remaining solution is then poured into a warm saturated solution of ammonium carbonate and allowed to stand for some little time. The precipitate which contains the alumina and the ferric oxide is again treated with carbonate of ammonia, and the warm filtrates, which are poured together, acidified with hydrochloric acid, the beryllia being thrown down by ammonia, washed, dried, and ignited.¹

Beryllium oxide is a white amorphous powder having a specific gravity of 3.08. When heated to the strongest temperature of a wind furnace it assumes the form of microscopic prisms resembling corundum (Rose). It may be easily obtained in this form by the ignition of a mixture of beryllium sulphate and potassium sulphate (Debray). Beryllia is perfectly insoluble in water, and only dissolves in dilute acids when it has not been strongly

¹ Joy, *Silliman's Journ.* [2] xxxvi. 83.

ignited. Concentrated boiling sulphuric acid dissolves it easily, and if it be fused with an alkali, and the cold mass treated with water, the beryllia goes into solution.

Beryllium Hydroxide, $\text{Be}(\text{OH})_2$. This is thrown down as a gelatinous precipitate when a beryllium salt is precipitated with ammonia. On drying, it forms a voluminous white powder which is converted into the oxide by ignition. It is easily soluble in acids, alkalis, and in ammonium carbonate. When the latter solution is boiled, a basic beryllium carbonate separates out.

SALTS OF BERYLLIUM.

136 *Beryllium Chloride*, BeCl_2 , is obtained in the form of white needle-shaped crystals when a mixture of the oxide and sugar-charcoal is ignited in a current of dry chlorine gas. It is deliquescent, and dissolves in water with evolution of heat. When the aqueous solution is allowed to evaporate over sulphuric acid, colourless crystals of the hydrated chloride, $\text{BeCl}_2 + 4\text{H}_2\text{O}$, separate out. Beryllium chloride forms double salts with platinum chloride, tin chloride, and mercuric chloride. Several basic chlorides have also been described; they are, however, not well defined.

Sulphates of Beryllium. The normal salt, $\text{BeSO}_4 + 4\text{H}_2\text{O}$, crystallizes from a hot saturated solution in quadratic pyramids which dissolve at the ordinary temperature in their own weight of water, possess a sweet taste, and effloresce on exposure to the air. On heating, they melt in the water of crystallization, leaving the anhydrous salt, which decomposes at a red-heat, with a residue of beryllia. A salt containing 7 molecules of water separates out from an acid solution of the normal salt, in large monoclinic crystals which retain one molecule of water of crystallization even at 150° . According to Klatzko this salt is isomorphous with magnesium sulphate, $\text{MgSO}_4 + 7\text{H}_2\text{O}$; this, however, appears, according to Maignac, to be doubtful. Beryllium readily forms basic sulphates. These are obtained by boiling the normal sulphate with beryllium carbonate, and form gelatinous or gum-like masses.

Beryllium Nitrate, $\text{Be}(\text{NO}_3)_2 + 3\text{H}_2\text{O}$, crystallizes with difficulty. It is extremely deliquescent, and is easily soluble in alcohol. When heated for twenty hours on the water-bath a

thick mass is obtained, which is readily soluble in water. This consists of the basic salt, $\text{Be}(\text{OH})\text{NO}_3 + \text{H}_2\text{O}$.

Phosphates of Beryllium. When a solution of beryllium nitrate is mixed with one of phosphate of soda a white amorphous precipitate of $\text{HBePO}_4 + 3\text{H}_2\text{O}$ is formed, and this loses two molecules of water when heated to 100° . If this salt be dissolved in the minimum quantity of phosphoric acid and alcohol then added, a gelatinous precipitate, which is a mixture of the above salt with the tetra-hydrogen phosphate, $\text{H}_4\text{Be}(\text{PO}_4)_2$, is obtained, the latter compound being soluble in water.

When a solution of sodium phosphate is added to a mixture of beryllium nitrate and sal-ammoniac a granular crystalline precipitate of $(\text{NH}_4)_2\text{Na}_2\text{Be}(\text{PO}_4)_2 + 7\text{H}_2\text{O}$ is formed.

Carbonates of Beryllium. The normal carbonate, $\text{BeCO}_3 + 4\text{H}_2\text{O}$, is obtained by passing carbon dioxide for a considerable time through water containing the basic carbonate of beryllium in suspension. The solution is allowed to evaporate over sulphuric acid in an atmosphere of carbon dioxide. Crystals are then formed which readily decompose with evolution of carbon dioxide.

When a solution of a beryllium salt is added to an alkaline carbonate, or when a solution of the oxide in ammonium carbonate is boiled, a basic carbonate separates out as a white powder which has the composition $\text{CO} \begin{cases} \text{OBe}(\text{OH}) \\ \text{OBe}(\text{OH}) \end{cases} + \text{Be}(\text{OH})_2 + 3\text{H}_2\text{O}$.

DETECTION AND ESTIMATION OF BERYLLIUM.

137 The salts of this metal do not impart any tint to the non-luminous gas-flame. The beryllium spark-spectrum contains two characteristic bright lines in the blue, having a wave length of 4572 and 4488 (Kirchhoff and Thalén). These lines are, however, not seen when the chloride is volatilized in the electric arc (Bunsen).

Beryllium may be readily separated from all other metals by the fact that its oxide is soluble in fixed alkalis, but insoluble in ammonia. In the process of analysis it is precipitated together with alumina, and it may be separated from this earth by treatment with carbonate of ammonia. For quantitative estimation and for separation from alumina and ferric oxide the method proposed by Joy (described on p. 233,) may be employed. The precipitate is treated with carbonate of ammonia,

the basic carbonate of beryllium being converted by ignition into the oxide, which is weighed.

The atomic weight of beryllium has been determined by Awdejew¹ by analysis of the sulphate, and found to be 9.2.

MAGNESIUM, Mg = 23.94.

138 Nehemiah Grew, a London physician living in the seventeenth century and for some time secretary of the Royal Society, published in the year 1695 an account of a peculiar salt found in the well-known mineral spring at Epsom under the title "*De salis cathartici in aquis Ebshamensibus et aliis contenti natura et usu.*" The medicinal value of this salt soon afterwards became widely celebrated, and the salt was known in England as Epsom-salt, and on the Continent as English-salt. The presence of the same substance was soon afterwards detected in other English mineral springs, and George and Francis Moutt in the year 1700 established a large manufactory of the salt near London, obtaining it from a spring at Shooter's Hill. In 1710 Høy discovered that the same salt could be obtained by crystallization from the mother-liquors of sea-water after addition of green vitriol (ferrous sulphate). The same salt was subsequently shown to exist by Fr. Hoffmann in the Sedlitz mineral water. Another compound of magnesium having medicinal value was also discovered at the beginning of the eighteenth century by a Roman ecclesiastic and termed by him *magnesia alba*. Why this name was given to it in contrast to *magnesia nigra*—as black oxide of manganese was then called—is not known. The mode of preparation of this substance was for some years kept secret, until in the year 1707 Professor Valentini, of Giessen, pointed out that *magnesia alba* can be obtained by boiling down the mother-liquors from the preparation of nitre and igniting the residual products. Shortly afterwards, in 1709, Professor Slevogt, of Jena, prepared the same substance by the precipitation of salt-petre mother-liquors with a fixed alkali. The substance thus obtained was a mixture of calcium carbonate and magnesium carbonate in varying proportions, and hence its medicinal action was very variable, and a satisfactory discrimination between lime and *magnesia* was rendered more difficult. The distinction between these two earths was first clearly pointed out by Black

¹ Pogg. Ann. lvi. 101.

in the year 1755. He showed that white magnesia is a compound of fixed air with a peculiar earth, which differs from lime in yielding a soluble sulphate. The properties of the new earth were subsequently more completely investigated by Bergman in 1775, but Black retained for it the name of magnesia. When Davy proved that this earth was the oxide of a metal, the name of *magnium* was given by him to the metal, the name *magnesium* or *manganesium* being at that time used to designate the metal contained in pyrolusite. This confusion was put an end to by the general adoption of the name magnesium for the metal contained in magnesia alba, and of manganese for that contained in pyrolusite.

Magnesium is a metal widely distributed in nature. It is found as magnesite, $MgCO_3$; dolomite, $(MgCa)CO_3$; kieserite $MgSO_4 + H_2O$; kainite, $MgSO_4 + KCl + 6H_2O$; carnallite, $MgCl_2 + KCl + 6H_2O$; spinelle, $MgOAl_2O_3$; asbestos $(MgCa)SiO_3$; talc, $H_2Mg_3Si_4O_{12}$; meerschaum, $H_2Mg_2Si_3O_9 + H_2O$, and as the chief constituent of many silicates such as augite, olivine, tourmaline, and serpentine, whilst it is contained in smaller quantities in most of the other silicates.

Magnesium sulphate, $MgSO_4 + 7H_2O$, is a chief constituent of certain saline springs, whilst the chloride, $MgCl_2$, occurs in salterns and in sea-water. Magnesium is also found in the animal and vegetable worlds. The bones of animals and the seeds of the cereals contain small quantities of magnesium phosphate, and ammonium magnesium phosphate separates out from the urine on standing, thus giving rise to many urinary deposits as well as to gravel and stone. The same salt likewise occurs in guano.

139 Preparation of Metallic Magnesium. Davy was the first to prepare metallic magnesium, but he did not obtain it in the pure state. It was first obtained as a coherent metal by Bussy,¹ who fused the anhydrous chloride of magnesium with potassium. Bunsen afterwards obtained it by the electrolysis of magnesium chloride, which is for this purpose fused in a porcelain crucible.² This crucible is divided into two by a vertical diaphragm made of the cover of a porcelain crucible rubbed down to the right shape (Fig. 71); on each side of this are placed the two poles made of gas carbon; the carbon of the negative pole is cut so as to form pockets, as shown in Fig. 72,

¹ *Journal de Chimie Medicale Ann.* 1830. p. 141.

² *Ann. Chem. Pharm.* lxxxii. 137.

inside which the metal is deposited: unless this precaution be taken, the metal, being lighter than the fused chloride, rises to the surface and burns. As it is difficult to prepare the pure chloride, Matthiessen employed a mixture of the chlorides of potassium and magnesium in nearly equal proportions, namely, in the ratio of 3 molecules of potassium chloride to 4 of magnesium chloride.¹ After having mixed the two salts in the proper proportions together with some chloride of ammonium the mass may be fused and electrolysed as in Bunsen's method. The pockets are, however, not required in this case, as the metal is specifically heavier than the fused mixture. A very convenient and simple way to reduce the metal, especially applicable for the lecture-table, is in a common clay tobacco-pipe over a gas

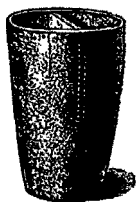

FIG. 71.



FIG. 72.

flame, the negative pole being an iron wire passing through the pipe stem, and the positive pole being a piece of gas-coke just touching the surface of the fused chloride.

Magnesium is now prepared on the large scale according to the method proposed by Caron and Deville.² For this purpose a mixture of 600 grams of fused

chloride of magnesium, 480 grams of finely-powdered fluor-spar, and 230 grams of sodium in small pieces is thrown into a red-hot crucible, which is then closed with the cover. After a short time a violent reaction takes place, and as soon as this is complete the contents of the crucible are stirred round with an iron rod in order to unite the small globules of metal into larger masses. To avoid the somewhat troublesome preparation of the anhydrous chloride, Wöhler suggested the use of the fused double chloride of magnesium and sodium. Sonstadt, in place of this, employed a mixture of potassium chloride and magnesium chloride, which may be also obtained by fusing the mineral carnallite. Care however must be taken that no kieserite is present, otherwise explosions may occur.

The manufacture of magnesium on the large scale was first effected by Sonstadt and Mellor. The process is essentially that of Caron and Deville carried on on a larger scale, an

¹ *Journ. Chem. Soc.* viii. 107.

² *Ann. Chim. Phys.* [3] lxvii. 347.

important improvement being the distillation of the crude metal, as this usually contains carbon, silicon, and nitrogen. The fact that magnesium can be readily distilled was indeed discovered by Deville and Caron, but first technically employed by Sonstadt. For this purpose the crude magnesium is placed in an iron crucible having an iron tube passing through from the bottom to within an inch of the lid. The crucible is filled with the crude metal to the level of the mouth of the tube, the lid carefully screwed and luted down, and the air displaced by a current of hydrogen or coal-gas. As the crucible becomes heated the magnesium distils over, passing through the upright tube into a box placed below, where, on the completion of the operation, it is found in the form of a coherent mass which is subsequently melted and cast into ingots or any other form that may be required. Magnesium is now prepared on the large scale by the Magnesium Metal Company at Patricroft near Manchester, and also by the American Magnesium Company at Boston. Matthiessen showed that the metal is malleable and ductile, and he pressed a small quantity into wire. Great difficulty was experienced in pressing it into wire on the large scale, but now, by machinery contrived for the purpose by Mr. Mather of Salford, the metal is pressed when in a semi-fluid state into wire of varying thicknesses and of any required length, and this afterwards flattened into ribbon.

140 Properties. Magnesium has a brilliant silver-white colour. It preserves its lustre in dry air, but in moist air it becomes covered with a film of oxide. Its specific gravity is 1.75. It melts at a red-heat and boils at a temperature somewhat above that at which zinc volatilizes. It occurs in commerce usually in the form of ribbon. When a piece of this is held in the flame of a candle it burns with an intensely white light, which has been seen at sea to a distance of twenty-eight miles. The light from burning magnesium wire is rich in chemically active rays, so that it is possible to photograph by means of it. Bunsen and Roscoe have determined the chemically active value of this light compared with that of the sun.¹ They showed that a burning surface of magnesium wire, which seen from a point at the sea's level has an apparent magnitude equal to that of the sun, effects, at that point, the same chemical action as the sun would do if shining from a cloudless sky at the height of 9° 53' above the horizon. On comparing the visible bright-

¹ *Phil. Trans.* 1850, p. 920.

ness of these two sources of light it was found that the brightness of the sun's disc as measured by the eye is 524.7 times as great as that of burning magnesium when the sun's zenith-distance is $67^{\circ} 22'$, whilst at the same zenith-distance the sun's *chemical brightness* was only 36.6 times as great. Hence the value of this light as a source of chemically active rays for photographic purposes becomes at once apparent. The application of magnesium as a source of light has become of technical importance. A burning magnesium wire of the thickness of 0.297 mm. evolves as much light as 74 stearin candles of which five go to the pound. If this light lasted one minute 0.987 m. of wire weighing 0.120 gram. would be burnt. In order to produce a light equal to 74 candles burning for ten hours whereby 20 lbs. of stearin is consumed, 72.2 grams or $2\frac{1}{2}$ oz. of magnesium would be needed.

The light from burning magnesium has been employed for signalling, and for military and naval purposes, and it is especially employed in pyrotechny. Metallic magnesium is also made use of in chemical analysis, and in toxicological investigations, where, as it is perfectly free from arsenic, it may be used with advantage in Marsh's apparatus in the place of zinc. It is also used in the estimation of nitrates and nitrites in drinking water, and in other cases, as a reducing agent.

MAGNESIUM AND OXYGEN.

141 *Magnesium Oxide or Magnesia*, MgO . This substance is formed when the metal burns in the air. It is also produced by the ignition of any magnesium salt containing a volatile acid. It is prepared on the large scale by igniting the carbonate, *magnesia alba*, and it forms a very fine light powder known as *magnesia usta* or *calcined magnesia*. It is almost insoluble in water, 1 part dissolving in 55,000 parts of both hot and cold water (Fresenius). It is tasteless, but in the moist state turns red litmus-paper blue. When ignited for some time it becomes more dense, undergoing a change of specific gravity from 3.07 to 3.61. When heated in the oxy-hydrogen flame *magnesia* melts, solidifying on cooling to an enamel-like mass which is hard enough to scratch glass. When *magnesia* is ignited in a current of hydrochloric acid it is obtained in the form of regular cubes and octohedrons, and if a mixture of *magnesia* and ferric

oxide be treated in this way black octohedrons of magnoferrite, MgO, Fe_2O_3 , are formed together with those of MgO containing a little ferric oxide; these are of a yellow colour, identical with periclase,¹ a mineral found at Monte Somma, near Naples.

Magnesium Hydroxide, $Mg(OH)_2$. This compound is obtained as a white precipitate when potash or soda is added to a magnesium salt. It occurs in nature as the mineral brucite, which is found embedded in serpentine with other magnesium minerals.

Magnesia is largely used as a medicine and has been employed by Caron for the purpose of making infusible crucibles.

SALTS OF MAGNESIUM.

142 *Magnesium Chloride*, $MgCl_2$, is contained in sea-water, in many brine-springs, and in various salt-beds, and is at present prepared in large quantities at Stassfurt. It is very soluble in water, 100 parts of water dissolving at the ordinary temperature about 130, and at the boiling point 366 parts of the salt. The hot concentrated solution deposits on cooling needles or prisms of the deliquescent hydrated salt, $MgCl_2 + 6H_2O$.

The hydrated salt is decomposed on heating, water and hydrochloric acid being given off and magnesia remaining. In order to prepare the anhydrous salt, sal-ammoniac is added to the solution; this is then evaporated to dryness, and the residue carefully heated until it is anhydrous, and afterwards ignited in a platinum crucible. The clear fused mass solidifies on cooling, forming a laminated crystalline solid which dissolves in water with evolution of heat. It possesses a bitter saline taste, and is now largely used for the purpose of dressing cotton goods. Magnesium chloride forms crystalline double salts with other chlorides, especially with those of the alkaline earths. Of these the following are the most important:

Potassium Magnesium Chloride or Carnallite, $MgCl_2, KCl + 6H_2O$. This compound crystallizes in rhombic prisms which deliquesce on exposure to the air, leaving a residue of potassium chloride.

Ammonium Magnesium Chloride, $MgCl_2, NH_4Cl + 6H_2O$, is

¹ H. Deville, *Ann. Chem. Pharm.* cxxx, 230.

deposited from solution in small rhombic crystals which dissolve in six parts of water.

Calcium Magnesium Chloride or tachhydrite, $2\text{MgCl}_2, \text{CaCl}_2 + 12\text{H}_2\text{O}$, occurs at Stassfurt in yellowish rounded masses which deliquesce on exposure to the air.

Oxychlorides of Magnesium. If strongly ignited magnesia be brought into contact with a concentrated solution of the chloride the mixture after standing for some hours solidifies to a mass so hard that it is capable of being polished (Sorel). A mass of this kind which had been exposed for six months to the air gave results on analysis which render it probable that it is a mixture of magnesium carbonate and the compound



This substance loses water on heating, but does not give off hydrochloric acid; and chloride of magnesium may be withdrawn from it by repeatedly boiling with water, leaving a residue of magnesium hydroxide as a hard non-crystalline mass resembling brucite.¹ If a solution of magnesium sulphate to which ammonia and sal-ammoniac have been added (a mixture frequently used in the laboratory) be allowed to stand for some time a crystalline precipitate having the composition

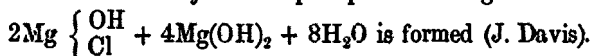

Magnesium Bromide, MgBr_2 , occurs in sea-water and in many brine-springs. The anhydrous salt is obtained by heating magnesium in bromine vapour, or by leading bromine vapour over an ignited mixture of magnesia and sugar charcoal. It forms a white crystalline mass which hisses and evolves heat when brought into contact with water, and crystallizes from a hot concentrated solution in needles, having the composition $\text{MgBr}_2 + 6\text{H}_2\text{O}$. On heating the crystals, hydrobromic acid is given off and magnesia is left behind.

Magnesium Iodide, MgI_2 , is found together with the bromide in sea-water and brine springs. It can be prepared by dissolving magnesia in hydriodic acid. On evaporation, hygroscopic crystals of a hydrated salt are deposited, which readily undergo decomposition with liberation of iodine.

Magnesium Fluoride, MgF_2 , occurs as the mineral sellaïte in colourless quadratic crystals, found at Montiers in Savoy. When pure magnesia is evaporated with an excess of aqueous hydro-

¹ Bender, *Ann. Chem. Pharm.* cxix 341.

fluoric acid to dryness, this same compound is obtained as an amorphous mass. When this is fused with common salt and the mass gradually cooled, it is deposited in crystals which, after washing with water, exhibit the same form as sellaïte (Cossa.)

143 *Magnesium Sulphate*, $MgSO_4$, occurs in nature as kieserite, $MgSO_4 + H_2O$, and epsom salt, $MgSO_4 + 7H_2O$. These two compounds can be readily distinguished by the action of water on them. Epsom salt is readily soluble in water, whilst kieserite is as difficultly soluble as gypsum. Kieserite occurs crystallized in rhombic prisms, but is more commonly found in granular masses which dissolve slowly when allowed to remain in contact with water, being gradually converted into epsom salt. Epsom salt occurs in many mineral-waters. It is found as epsomite or hair-salt in silky fibres and fibrous crusts at Idria in Carniola, in the gypsum quarries of Montmartre near Paris, and in various other localities. The floors of the limestone caves in Kentucky, Tennessee, and Indiana are in many instances covered with minute crystals of epsomite mingled with earth. In the Mammoth cave in Kentucky it adheres in loose masses like snow balls (Dana).

The manufacture of magnesium sulphate from the upper layers of salt (*Abraumsalz*) at Stassfurt is carried on on the large scale. The crude kieserite is placed in sieves in water. The magnesium chloride and finely divided chloride of sodium dissolve whilst the kieserite falls through the meshes of the net in small powder, and larger pieces of rock-salt, anhydrite, and earthy impurities remain behind. This powder is then brought into conical wooden moulds in which it is allowed to remain, and in which it soon becomes a hard coherent mass, inasmuch as a portion of the salt combines with water to form the hepta-hydrate which binds together the remaining powder of the kieserite. This kieserite-stone is then dried and powdered, and contains 80 to 90 per cent. of magnesium sulphate, and from 1 to 2 per cent. of common salt. It is either brought into the market in this form or worked up into epsom salt. Sulphate of magnesium was formerly produced in considerable quantity by treating either native carbonate of magnesium or dolomite with sulphuric acid, the gypsum formed in the latter case, being much less soluble than magnesium sulphate, is easily separated from it. Formerly, also, dolomite was burnt, the lime dissolved out by crude pyroligneous acid, and the residual magnesia treated with sulphuric acid (Henry).

Magnesium sulphate crystallizes from a hot concentrated solution in four-sided rhombic prisms shown in Fig. 73, containing seven molecules of water, and isomorphous with the corresponding sulphates of zinc and nickel. As a rule, the commercial salt occurs in the powdery form consisting of minute delicate needles obtained by quick crystallization of a concentrated solution. The crystals are not efflorescent, but the commercial salt sometimes becomes moist in contact with air in consequence of the presence of traces of magnesium chloride. The crystals possess

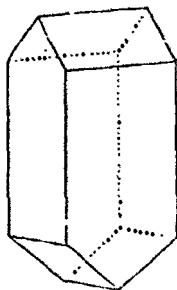

FIG. 73.

an unpleasant saline bitter taste and have a specific gravity of 1.685 (Schiff). On heating, they melt in their water of crystallization, and lose six molecules at 150°, the last molecule being termed by Graham *constitutional water*, because it is not driven off until a temperature of 200° is reached. The salt is freely soluble in water; according to Gay-Lussac 100 parts of water at 0° dissolve 25.76 parts of the anhydrous salt and an additional 0.47816 for every degree above this. Magnesium sulphate is insoluble in absolute alcohol.

When a boiling and concentrated solution of magnesium sulphate is placed in a closed vessel it remains supersaturated when cold. Such a solution may stand for weeks or months without solidification, but milk-white crystals are sometimes deposited which contain six molecules of water, and, sometimes, monoclinic tables with seven molecules of water are obtained. From this it is seen that epsom salt is dimorphic; this is also shown by the fact that it crystallizes as an isomorphous constituent with monoclinic ferrous sulphate, $\text{FeSO}_4 \cdot 7\text{H}_2\text{O}$. Epsom salt is largely used as a purgative, and, like the chloride, is employed as a dressing for cotton goods. It is also used in dyeing with aniline colours, as goods thus dyed are found to stand the action of soap better; this is probably due to the formation of an insoluble magnesia soap. Kieserite is also used in the preparation of glauber-salt and potassium sulphate, and also as a manure.

Magnesium sulphate forms a series of characteristic double salts with the sulphates of the alkali-metals. These have the general formula $\text{MgSO}_4 \cdot \text{M}'_2\text{SO}_4 \cdot 6\text{H}_2\text{O}$, and crystallize in monoclinic prisms. When the anhydrous sulphate is dissolved

in hot concentrated sulphuric acid the solution on standing deposits the compound $MgSO_4 + H_2SO_4$, in six-sided tables, which soon absorb moisture from the air and are thereby decomposed.¹

Magnesium Nitrate, $Mg(NO_3)_2$. This salt occurs in the mother-liquors from the salt-petre manufacture, and in the surface water of towns, having been first detected by Berzelius in the well-water of Stockholm. It is prepared by dissolving magnesia alba in nitric acid. The hydrated salt, containing six molecules of water, crystallizes from concentrated solutions in prisms and needles, which dissolve in half their weight of cold water and in nine parts of alcohol of specific gravity 0.84, but are less soluble in pure alcohol.

144 *Phosphates of Magnesium. The Normal Orthophosphate*, $Mg_3(PO_4)_2$, occurs in small quantities in the seeds of the cereals and in bones. It is obtained in the form of a white precipitate when a solution of normal sodium orthophosphate is added to a solution of epsom salt. One part of the salt dissolves in 5,000 parts of water. A phosphato-fluoride of magnesium having the formula $2Mg_3(PO_4)_2 + MgF_2$ occurs in nature as wagnerite.

Hydrogen Magnesium Orthophosphate, $HMgPO$, is obtained when a solution of epsom salt is mixed with one of common phosphate of soda; on standing, hexagonal needles of the acid salt containing seven molecules of water are deposited. These dissolve in 322 parts of cold water. If this solution be heated it becomes milky owing to the separation of the insoluble normal salt, a tetra-hydrogen phosphate $H_4Mg(PO_4)_2$ remaining in solution. This latter compound has not been obtained in the pure state.

Magnesium Ammonium Orthophosphate, $Mg(NH_4)PO_4 + 6H_2O$. This salt, a frequent constituent of urinary calculi, was discovered by Fourcroy. It is produced in the putrefaction of urine, and large crystals of it have been found in some varieties of guano. It is formed when an ammoniacal solution of sal-ammoniac is mixed with a solution of magnesium sulphate, and a soluble orthophosphate then added. If the solution be dilute, the precipitate takes some time to form, and deposits in small crystals which attach themselves to the sides of the vessel, especially upon points presenting any roughness or inequality, as where the beaker-glass has been scratched. It separates in

¹ Schiff, *Ann. Chem. Pharm.* cxviii. 365.

this way from extremely dilute solutions, affording a very delicate test either for magnesium or for phosphoric acid. According to Graham the best mode of obtaining it in distinct crystals is to mix 600 parts of hot water with four parts of strong ammonia; then add seven parts of crystallized phosphate of soda, two parts of sal-ammoniac and four parts of sulphate of magnesium. The crystals which are thus deposited are transparent quadratic prisms. One part of the salt dissolves in 15,000 parts of water at 15° and in 44,000 parts of ammoniacal water, whilst in presence of sal-ammoniac it is somewhat more readily soluble. At 100° the salt gives off five molecules of water without loss of ammonia, and at a higher temperature the whole of the water and ammonia escapes, pyrophosphate of magnesium, $Mg_2P_2O_7$, remaining behind.

The *Arsenates of Magnesium* closely correspond to the phosphates.

145 Carbonates of Magnesium. *Normal magnesium carbonate*, $MgCO_3$, occurs in nature as magnesite, a mineral isomorphous with calc-spar. The same mineral frequently occurs in compact or granular masses, and is found in large quantities in various localities, especially in the island of Eubœa. The normal carbonate is also formed by the action of magnesium chloride on calcium carbonate (Marignac). It has a specific gravity of 3.056; it is not easily soluble in dilute acid, but dissolves in water saturated with carbon dioxide, being soluble in larger quantity when the pressure to which the liquid is subjected is increased. According to Wagner¹ one part of magnesium carbonate dissolves at 5° in

761	parts of carbonic acid-water	under a pressure of 1 atmosphere
134	“	“ “ 3 atmospheres
110	“	“ “ 5 “
76	“	“ “ 6 “

The solution has an alkaline reaction and a bitter taste. If it be placed in a partially closed flask at 50°, crystals of the hydrated carbonate $MgCO_3 + 3H_2O$ are deposited from solution, whilst at a lower temperature tabular crystals containing five molecules of water separate out. When evaporated to dryness, the solution yields a crystalline powder which, examined under the microscope, is found to consist of crystals having the form of arragonite.² But

¹ *Journ. Prakt. Chem.* cii. 233.

² H. Rose, *Pogg. Ann.* xlii. 366.

if the solution be heated to 300° in a vessel closed by a porous stopper through which the carbonic acid can slowly escape, microscopic rhombohedrons of the form of native magnesite are deposited.¹ Carbonate of magnesium is, therefore, isodimorphous with calcium carbonate. If a solution of epsom salt be precipitated with an excess of sodium carbonate, and the precipitate boiled until it becomes crystalline, a basic carbonate having the composition



is thrown down in the form of small granular crystals containing two molecules of water of crystallization. The *magnesia alba* of the shops is also a basic carbonate, which usually possesses the following composition :



It contains from two to three molecules of water, and is a very light powder (*magnesia alba levis*). This is obtained by precipitating a solution of epsom salt or magnesium chloride with sodium carbonate. If the precipitation be carried on at the boiling temperature a much more dense precipitate is obtained (*magnesia alba ponderosa*).

Another method of preparation is that patented by Pattinson, which consists in igniting dolomite (a mixture of carbonates of calcium and magnesium), and then treating it with water and carbon dioxide under pressure, when the carbonate of magnesium dissolves in the carbonic acid more readily than does the carbonate of calcium ; the solution of bicarbonate of magnesium which is formed is decanted from the insoluble carbonate of calcium and decomposed by a current of steam. The salt thus obtained is very white and of a loose texture.

Magnesia alba is almost insoluble in water. It dissolves, however, readily in solution of ammoniacal salts, owing to the formation of ammonium carbonate and a soluble double salt. For this reason ammonium carbonate does not precipitate a magnesium salt completely, and no precipitate occurs in the presence of sal-ammoniac. The mineral termed hydromagnesite, possessing the same composition as *magnesia alba*, occurs in small white monoclinic crystals. These basic carbonates of magnesium may be represented as compounds of the normal carbonate with the hydroxide :

¹ *Séniarmont, Ann. Chim. Phys.* [3] xxx. 129.



146 *Magnesium Sulphide, MgS.* This substance is not formed in the wet way, but is obtained when a mixture of magnesium filings and sulphur is heated to dull redness in a current of sulphur vapour.¹ The product is a brown, coherent, hard, and brittle coke-like mass, mixed with a small quantity of magnesium oxide and some undecomposed metal. On exposure for some time to the air the difficultly fusible sulphide slowly tarnishes, and evolves sulphuretted hydrogen, and the granular and bright steel-grey fracture becomes dull and coated with a grey oxide. It is slightly soluble in water, yielding a straw-yellow solution, but on exposure to the light it deposits sulphur, and becomes colourless. This solution doubtless contains magnesium hydrosulphide, $\text{Mg}(\text{SH}_2)$, which may also be obtained by passing sulphuretted hydrogen into water containing magnesia in suspension.² It is an extremely unstable compound, and on exposure to the air, or when heated, gives off sulphuretted hydrogen, leaving magnesia behind.

Magnesium Nitride, Mg_3N_2 . Deville and Caron, when preparing magnesium, observed that the distilled metal sometimes appears covered with small transparent needles,³ which decompose in moist air with formation of ammonia and magnesia, and therefore contain a nitride of magnesium. This compound was obtained in the amorphous state by Briegleb and Geuther,⁴ by igniting magnesium in ammonia or in nitrogen gas. The nitride of magnesium thus prepared is a greenish-yellow amorphous mass, which when heated in dry oxygen gas is converted, with bright incandescence, into magnesia. On exposure to the air or when treated with water it is quickly decomposed into ammonia and magnesia, so much heat being evolved in the latter case that the water boils. When heated in a current of sulphuretted hydrogen gas, ammonium sulphide and magnesium sulphide are formed.

Magnesium Silicide was obtained by Wöhler as a by-product in the preparation of metallic magnesium, by fusing together a mixture of sodium, magnesium chloride, and sodium silico-fluoride. According to Geuther it is best prepared by filling a Hessian

¹ Parkinson, "On the Alloys of Magnesium," *Journ. Chem. Soc.* xx. 127.

² Berzelius, *Pogg. Ann.* vi. 443.

³ *Ann. Chim. Phys.* [3] lxxvii. 348.

⁴ *Ann. Chem. Pharm.* cxxiii. 223.

crucible with alternate layers of fused and powdered sodium chloride and a mixture of 2.5 parts of common salt, 7 parts of sodium silico-fluoride, and 2.5 parts of magnesium. The whole is then covered with common salt and the crucible exposed to the heat of a wind-furnace. When the reaction is finished the mass is stirred round, and the cold regulus treated with dilute sal-ammoniac solution, which dissolves the magnesium, but, in the cold, only slightly attacks the silicide.¹ This compound forms lustrous metallic crystals, which have the formula Si_3Mg_5 . When treated with hydrochloric acid, a mixture of hydrogen and silicon hydride is evolved, and silicoformic anhydride (see Vol. I., p. 561) is formed. From this it would appear that magnesium silicide is a mixture of SiMg_2 and SiMg , its decomposition being thus represented:

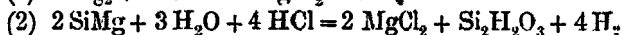
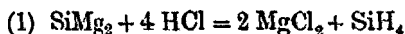

DETECTION AND ESTIMATION OF MAGNESIUM.

147 Magnesium and its compounds do not impart any tint to the non-luminous gas-flame. The spark spectrum of magnesium is, however, very characteristic (Bunsen, Kirchhoff, Thalén), giving lines in the green coincident with Fraunhofer's *b*. The brightest of these lines is situated very close to an air-line, and for this reason it is better to observe the magnesium spark in an atmosphere of hydrogen, or in one of coal-gas, than in the air (Bunsen).

In the course of ordinary qualitative analysis, magnesium is obtained together with the alkali-metals, as it is not precipitated by carbonate of ammonium in presence of sal-ammoniac. The presence of magnesium is readily detected by the addition of sodium phosphate to a portion of the solution, as on standing for a short time a crystalline precipitate of $\text{Mg}(\text{NH}_4)\text{PO}_4 + 6\text{H}_2\text{O}$ is deposited. The formation of this precipitate is greatly accelerated by stirring the solution with a glass rod when the crystals are deposited where the rod has scratched the glass.

The quantitative estimation of magnesium in the presence of the alkalis is accomplished by the method proposed by Berzelius. The solution which must contain the metals in

¹ *Journ. Prakt. Chem.* xcv. 424.

the form of chlorides, as is indeed always the case in the analysis of silicates, &c., is evaporated to dryness, and the residue ignited in order to volatilize the ammoniacal salts. The fixed residue is then warmed with a small quantity of water, and a little finely divided oxide of mercury added; the mixture again evaporated to dryness on a water-bath, and the residue ignited in order to expel the mercuric chloride and excess of oxide. The residue contains the magnesium in the form of oxide, whilst the alkali-metals remain as chlorides, and are soluble in water. The undissolved magnesia after having been well washed is dissolved in hydrochloric acid, and precipitated as the ammonium magnesium phosphate, which must be washed with dilute ammonia. After ignition the magnesium is estimated as pyrophosphate.

The atomic weight of magnesium has been accurately determined by Scheerer and Marchand.¹ For this purpose they analysed a pure specimen of magnesite, obtaining the number 23.98 as a mean of several experiments.

ZINC. Zn = 64.9.

148 The ancients were acquainted with the alloy of zinc and copper which we term brass, but they were not aware that it contained any other metal besides copper, and it was only after some time that a more accurate examination of brass and the ores which were employed for its production led to the recognition of zinc as an elementary body. Aristotle, in the fourth century B.C., mentions the preparation of brass under the name of Mossincean copper, which he describes as being bright and light-coloured, not produced by the addition of tin, but by its having been melted with a peculiar earth found on the shores of the Black Sea. The early use of brass is clearly proved by the following analysis by Tookey, quoted by Percy, of an undoubtedly genuine Greek coin of Trajan struck in Caria A.D. 110:—

Copper	77.590
Zinc	20.700
Tin	0.386
Iron	0.273
	<hr/>
	98.949

¹ Journ. Prakt. Chem. 1. 385.

This ore, by means of which copper could be coloured yellow, was termed *καδμεία*, or *cadmia*, by Dioscorides and Pliny. The same word is also used by the latter author to designate the sublimate, consisting of impure oxide of zinc, found in the brassfounders' furnaces. It has already been stated in the Historical Introduction that the older alchemists were acquainted with the means of turning copper of a yellow colour. The material by which this change was brought about was termed in the Latin translation of their works *tutia*. Agricola believed that brass was a mixture of copper and earth termed *galmei* or *calamine*, and he describes the employment of *tutia* in the place of the natural ore as follows: "Sunt qui in *cadmiæ* fossilis locum *cadmiam* fornacum substituunt."

The word zinc is first found in the writings of Basil Valentine. It occurs in his *Currus triumphalis Antimonii*, and also in his *Last Testament*. "The mineral kingdom contains or includes all ores, metals, minerals, *marcasites*, *calx*, *zinken*, all sorts of quartz, bismuth, and stones, whether they are noble or base." Valentine, however, does not appear to have classed zinc with the metals proper, and it was Paracelsus who first pointed out that zinc was a metal. He says in his treatise on minerals: "There is another metal called the *zinken*, which is unknown to the fraternity, and is a metal of a very singular kind." In other places he describes it as a bastard or semi-metal. The word zinc occurs in many subsequent authors, and sometimes it is employed to denote the metal, at other times the ore from which the metal is obtained. Libavius was the first to investigate the properties of zinc more exactly, although he was not aware that the metal was derived from the ore known as *calamine*. He states that a peculiar kind of tin is found in the East Indies called *calaëm*. Some of this was brought to Holland and came into his hands. He describes its outward appearance and general properties minutely, and compares them with those of the other metals, laying very particular stress upon the fact that when heated in the air this metal takes fire and burns. The exact nature of zinc and its ores continued doubtful during the seventeenth century. Glauber, it is true, stated that *calamine* is an ore of zinc, but Leuery so late as 1675 believed that zinc was identical with bismuth, and Boyle often employed the names zinc and bismuth indiscriminately for the same substance, also employing the word *spiauter* (our English spelter), a name apparently of Eastern origin. In

general it was believed that the brass which was obtained from copper and calamine contained the latter substance as such. The view that brass is an alloy was first put forward by Kunkel at the end of the seventeenth century. He says in his *Laboratorium*, "I have already remarked in my annotations that calamine allows its mercurial (metallic) part to pass into the copper and form brass. For thou wilt never believe that as a *sal* it could tinge copper; as a *terra* it cannot enter it, since it would make the copper brittle, and moreover could not tinge it." Stahl afterwards gave it as his opinion that calamine can turn copper into brass by being first converted into zinc.

The preparation of zinc on the large scale appears to have been first carried out in England. According to Bishop Watson, zinc-works were first established at Bristol about the year 1743. "In about the year 1766 Watson visited Mr. Champion's works near Bristol and saw the process of making zinc, which at that time was kept rigidly secret. Many years afterwards he published an accurate description of this process, which is the same as that hereafter described as the English process"¹ (Percy).

The first Continental zinc works were erected in 1807 at Liège.

Zinc is said to have been found in the native state near Melbourne in Australia, but it occurs chiefly as smithsonite or zinc-spar, ZnCO_3 , found near Altenberg, in the neighbourhood of Aix-la-Chapelle, at Wiesloch, in Belgium, Spain, Siberia, and North America, as well as at Alston Moor, Lead Hills, Donegal, and Matlock in Great Britain. It also occurs as siliceous calamine, $\text{Zn}_2\text{SiO}_4 + \text{H}_2\text{O}$, found together with zinc-spar, and as zinc blende or zinc sulphide, ZnS , occurring with galena, fluor-spar, &c., in England, in the Harz, in Saxony, in Bohemia, in North America, and in other localities.

Other ores of zinc are franklinite, $(\text{ZnFe})\text{O} + \text{Fe}_2\text{O}_3$; red zinc ore, or oxide of zinc, which derives its peculiar colour from the presence of red oxide of manganese; hydro-zincite, $\text{ZnCO}_3 + 2\text{Zn}(\text{OH})_2$; aurichalcite, $2\text{CuCO} + 3\text{Zn}(\text{OH})_2$; zinc sulphate, $\text{ZnSO}_4 + 7\text{H}_2\text{O}$, and gahnite or zinc-spinelle, $\text{ZnO} + \text{Al}_2\text{O}_3$, &c.

Zinc has been found in the ashes of the yellow violet (*Viola Calaminaris*), growing in Rhenish-Prussia in soil which contains zinc. In former times calamine was the only ore of zinc from which the metal was extracted. At the present time, however, large quantities of zinc silicate, a mineral occurring

¹ *Metallurgy*, i. 521.

with the carbonate, are employed for the preparation of zinc, whilst zinc blende is also used. In America the metal is extracted from franklinite and from the red zinc ore.

149 Smelting of Zinc.—The first process in the preparation of zinc usually consists in the roasting of the ore in order to drive off the carbonic acid and water which it contains, and, in the case of zinc blende, to convert the sulphide into oxide. In roasting the latter ore great care has to be taken to prevent the formation of zinc sulphate, a salt which requires a very high temperature for its decomposition, and which would be again converted, in the process of reduction which follows, into sulphide, and thus cause a considerable loss. Blende is usually roasted in open furnaces, but an improved form of furnace, in which the sulphur dioxide evolved is condensed, has been proposed by Messrs. Hasenclever and Helbig, and this is now frequently employed.¹

The reduction of the zinc ores was formerly carried on in England by a process termed distillation *per descensum*. The furnace employed closely resembles those in use in glass-works. Crucibles (i. Fig. 74) charged with the roasted ore, mixed with half its weight of powdered coal, are placed in these furnaces. Each crucible is closed at the top, but has an opening

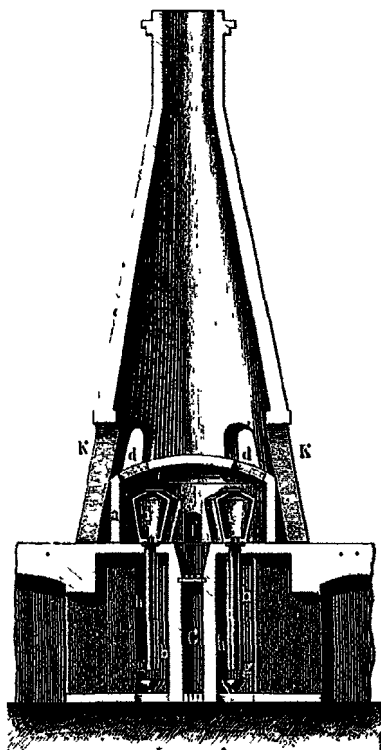

FIG. 74.

at the bottom which is plugged with a piece of wood, and an iron tube (*h h*), fitting close to the bottom of the crucible, is arranged as a receiver into which the vapour of the zinc is condensed.

¹ *Zeitschr f'ur deutsch Ing.* 1872, 505.

The wooden plug is soon converted into charcoal by the heat of the furnace, and this, whilst sufficiently porous to allow the vapour of the metal to pass, stops any coal or ore from falling down into the tube. The zinc collects in the tube and in the vessel *gg* placed below in the form of drops or powder. It requires to be re-melted in an iron pot, and is then cast into slabs and sent into the market. This process is not economical, and it necessitates a much larger consumption of fuel than the following plans, which are therefore now more generally adopted.

150 In the *Belgian process*, tube-shaped retorts made of refractory fire-clay are employed. In these the mixture of pounded coal and roasted ore is placed. Each retort (*a*, Fig. 75) is about 1 metre in length, and has an internal diameter of about 0·2 m. To the open end a long conical earthenware pipe (*b*), 0·24 m. in length, is fitted, and the end of

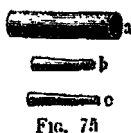

Fig. 75

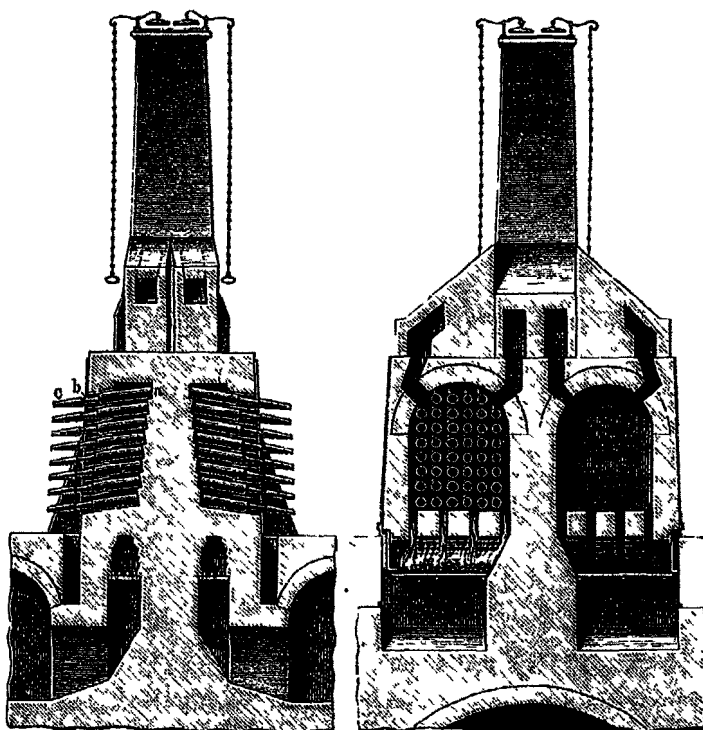

Fig. 76.

Fig. 77.

this adapter is fitted into a sheet-iron condenser (c), the extremity of which is open and about 2.5 cm. in diameter. Forty-eight or more of these retorts are placed in the furnace, being set in a slanting direction to allow the metal to run out. The furnace has the form of an arched recess (Fig. 77), and four such furnaces are usually built together in one mass of brickwork. A mixture of 2 parts of ground roasted ore and 1 part of coal-dust is brought into the retorts, each holding about 40 lbs. of the mixture. As soon as the temperature has risen high enough, the reduction begins, and carbon monoxide is evolved and burns from the end of the clay adapter with a blue flame. After a while the flame becomes much more brilliant, showing that the metal is beginning to volatilize; the iron condenser is then placed on to the end of the clay adapter, and the metallic vapours are thus condensed. After about two hours the iron condenser is taken away and the oxide knocked out. A ladle is then held under the mouth of the clay adapter, and the melted zinc which has accumulated in the adapter and in the retort is scraped out. The iron receiver is then again fixed in its place, and after a second couple of hours the operation is repeated. It is completed in about eleven hours. The exhausted charge is then removed from the retort and a fresh one introduced. In this way two charges are worked off from each retort in twenty-four hours.

In the *Silesian process*, which is the one now most generally adopted, clay retorts or muffles (Fig. 78) about 1 metre long are arranged side by side in the horizontal bed of a reverberatory furnace (Figs. 79 and 80). No less than thirty or forty muffles are thus arranged, and these may contain 1,500 to 2,000 kilos. of the mixture of coal and roasted ore. This mixture is introduced through a luted clay door in the muffle or retort. When the temperature has risen sufficiently high, the vapour of the reduced zinc passes out of the retort by a bent clay pipe (A, Fig. 78), and condenses in an iron tube, falling down into an iron tray placed in a closed recess (o) (Fig. 79), in the furnace. In this process a considerable quantity of zinc is burnt, producing zinc oxide, known as *Silesian zinc-flowers*. Siemens' gas regenerator is now being employed in the zinc-works on the Continent, and in some cases the lower portion of the furnace is filled with *Silesian muffles*, whilst in the upper part of the furnace the *Belgian method* is employed.

151 Commercial zinc is seldom perfectly pure. It almost

always contains small quantities of lead, iron, and carbon. Not unfrequently silver, cadmium, and small traces of arsenic, antimony, and other metals are met with. The chemical purity of zinc may be readily ascertained by the fact that, when pure, it is scarcely attacked by dilute sulphuric acid, whereas common

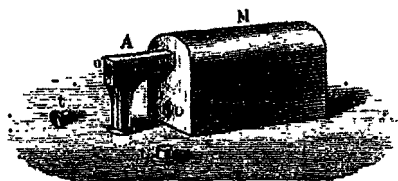

FIG. 78.

impure zinc dissolves readily under the same circumstances. If, however, a few drops of chloride of platinum be added to the acid liquid in which the pure zinc is placed, a rapid evolution of hydrogen begins, inasmuch as the platinum is deposited upon the zinc, and a galvanic current is thus established.

Properties. Zinc has a bluish-white colour, melts at a temperature of 433° (Person), and boils at 1040° (Deville and Troost). If zinc be heated to its melting-point, but not to a higher temperature, poured out upon a non-conducting surface, and the molten metal then poured off from the portion which has solidified, the metal may be obtained in the crystalline form, consisting of hexagonal prisms and pyramids. Commercial zinc has a coarsely laminar texture. It is moderately hard, difficult to file, and when bent after fusion it emits a crackling noise, not so loud as that emitted by tin. Zinc exhibits the greatest degree of ductility and malleability at temperatures between 100° and 150° , at which temperatures it may be drawn out into wire and rolled into plate.¹ On the other hand, it is so brittle at 205° that it may be powdered in a mortar. The specific gravity of zinc is 6.9. It is largely employed in the form of sheets, for a variety of technical purposes, and also much used in the manufacture of brass, an alloy of the metal with copper. Zinc is also used for desilverizing lead, for galvanizing iron, for electrical batteries, and for a great number of other purposes. Metallic zinc in the form of fine dust is obtained in considerable quantity in the manufacture of the metal, mixed with a certain amount of

¹ Hobson and Sylvestra, *Gilbert's Ann.* xxiv. 104.

oxide of zinc. This mixture, called *zinc dust*, is a valuable reducing agent, often used for this purpose in organic chemistry, and also on a large scale for the reduction of indigo blue: it is likewise employed as a paint for iron articles. In

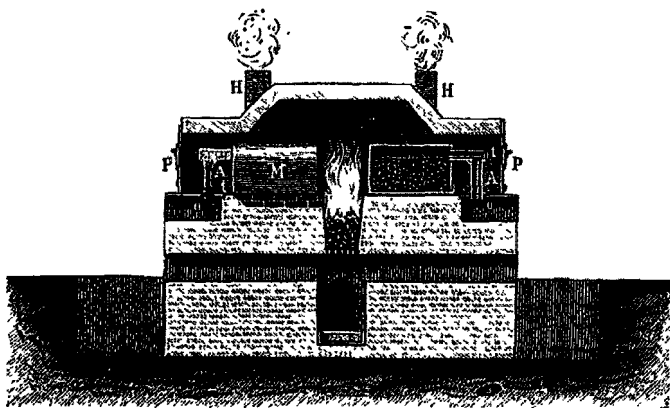

FIG. 79.

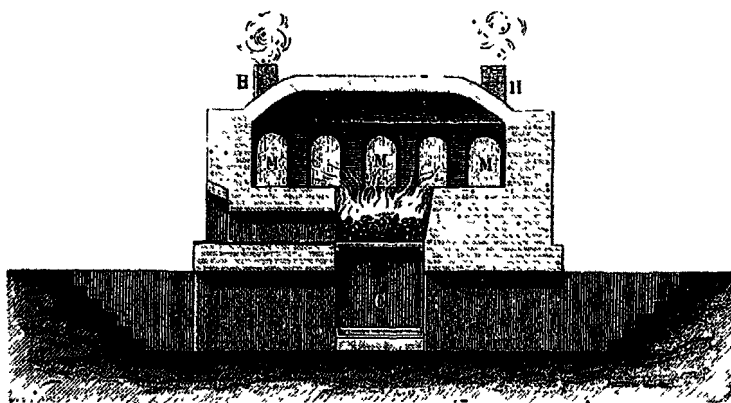

FIG. 80.

order to free the powder from oxide of zinc, it is only necessary to allow it to remain for some time in contact with very dilute hydrochloric acid. The residue is first washed with water and then with pure alcohol, after which it is dried and preserved.

ZINC AND OXYGEN.

152 *Zinc Oxide*, ZnO. This compound occurs as the mineral zincite or red zinc ore, which consists of a mixture of zinc oxide with 0.7 to 12 p.c. of red oxide of manganese. It occurs, especially in New Jersey, in red or orange-yellow hexagonal crystals or in a granular mass. Zinc oxide is also occasionally found in the crystalline state in brass-melting furnaces, as well as in the zinc furnaces. It has already been mentioned that the finely divided oxide was known to the ancients as tutia, pompholyx or flowers of zinc, and Dioscorides states that if too much cadmia be employed in the manufacture of brass, pompholyx is formed like tufts of wool,¹ whence the name *Lana philosophica* was given to this substance by the alchemists. The similarity between the oxide of zinc obtained by combustion and flakes of snow led the alchemists to term it *nix alba*; this was translated into German as "weisses Nichts," and retranslated into Latin as "nihilum album."

Zinc oxide is known in commerce as zinc-white, and is prepared on the large scale and used as a paint. It is obtained by the distillation of zinc in earthenware retorts, the burning vapours of the zinc being brought into chambers through which a current of air is passed and the oxide allowed to deposit in a second chamber. The preparation of zinc-white directly from the ore has lately been carried on at Liège.²

The combustion of zinc can be shown by holding thin zinc turnings in the flame of a lamp, or better still, by placing zinc in a white-hot crucible, and exposing the surface to the air or stirring it with an iron rod, when the metal burns with a bright white flame.

Zinc oxide is prepared for pharmaceutical purposes by precipitating a solution of zinc sulphate with sodium carbonate and igniting the basic carbonate thus thrown down. As the commercial zinc sulphate frequently contains epsom salt (magnesium sulphate) as an impurity, it is best, in order to obtain the pure compound, to dissolve zinc in dilute sulphuric acid, and then either to treat the solution with sulphuretted hydrogen, or to allow the solution to remain for some time in

¹ πομφόλυξ ἐρίων τολύπαις αφομοιοῦται.

² See Hofmann's *Ber. Entw. Chem. Ind.*, i, 919.

contact with metallic zinc, in order to precipitate the cadmium, copper, arsenic, and other metals. To the filtrate a small quantity of an alkaline solution of sodium hypochlorite is added, in order to throw down the iron, manganese, &c.; then the solution is filtered, and poured in a thin stream into a boiling solution of pure sodium carbonate. The precipitate is washed with boiling water, and, after drying, it is gently ignited in a glass flask or platinum basin.

Zinc oxide has a specific gravity of 5.6; when hot it possesses a lemon-yellow colour, but on cooling it becomes white. When heated in the oxy-hydrogen flame it emits a brilliant white light. After being thus heated, it phosphoresces for some time in the dark.

Zinc Hydroxide, $Zn(OH)_2$, is obtained as a white powder, when caustic potash or soda is added to a solution of zinc salt. It is very soluble in an excess of the reagent, and it is upon this fact that the reaction of zinc dissolving in alkalis with evolution of hydrogen depends.¹ This reaction takes place especially quickly in presence of metallic iron. If metallic zinc be allowed to remain under the surface of a solution of ammonia in contact with iron or copper, zinc hydroxide crystallizes from the solution in colourless transparent rhombic prisms (Runge); and if a saturated solution of the hydroxide in caustic potash be allowed to stand, regular octohedrons of the compound, $Zn(OH)_2 + H_2O$, are formed (Bödeker).

SALTS OF ZINC.

153 The salts of zinc are colourless, unless the acid be coloured. The normal soluble salts redden litmus solution; they possess a disagreeable metallic taste, and act as poisons and emetics.

Zinc Chloride, $ZnCl_2$. Impure chloride of zinc was first prepared by Glauber. He describes in his *Furnis novi philosophici*, published in 1648, an *oleum lapidis calaminaris*, "obtained by dissolving calamine in spirit of salt, and heating the solution, when a thick *oleum* remains as unctuous as olive-oil, and not particularly corrosive, for the spirit of salt has itself been weakened by corroding the calamine and thus lost its acrimony. This oil must be well preserved against the action of the air, otherwise in a few days it attracts so

¹ See Vol. I. p. 104.

much air to it that it becomes a watery liquid." In 1735 Hellot prepared "butter of zinc," by distilling flowers of zinc with sal-ammoniac; and Pott, in 1741, obtained the same substance by distilling zinc with corrosive sublimate. Gallisch, in 1782, noticed that zinc deliquesces when exposed to the action of dephlogisticated muriatic acid gas (chlorine), and Westrumb, in 1790, observed that when finely divided zinc is dropped into the gas the metal takes fire. This historical sketch serves to show the methods by which the anhydrous chloride may be obtained. The same substance is formed when a mixture of anhydrous zinc sulphate and calcium chloride is distilled (Persoz).

Zinc chloride is a white or usually greyish-white mass, soft, like wax, at the ordinary temperature, and melting when heated a little above 100° (H. Davy), and subliming at a higher temperature in white needle-shaped crystals. It is very deliquescent, and is soluble in alcohol.

A concentrated solution of zinc chloride is best obtained by dissolving zinc, its oxide, or carbonate, in hydrochloric acid, and evaporating the solution to the consistency of a syrup. On the addition of a little concentrated hydrochloric acid to this syrupy solution, small deliquescent octohedrons separate out, having the composition $ZnCl_2 + H_2O$. Zinc chloride is used in surgery as a caustic, and is employed in the laboratory for the purpose of separating the elements of water from many organic substances. Thus, for instance, when it is heated with strong alcohol, ether is formed :



It is also employed on a large scale, as is magnesium chloride, for weighting cotton goods. When its solution is evaporated, hydrochloric acid is evolved and basic salts are formed; these may also be obtained by boiling the solution of the chloride with zinc oxide and adding water, when precipitates are formed consisting of mixtures of $Zn(OH)Cl$ and $Zn(OH)_2$ in varying proportions. When a solution having a specific gravity of 1.7 is boiled with an excess of oxide, a liquid is formed which has the property of dissolving silk, and this is used for separating silk fibres from those of wool, or of cotton or linen, all of which dissolve in a solution of normal zinc chloride.

Zinc Bromide, $ZnBr_2$, is formed when bromine vapour is

passed over the metal heated to redness. It corresponds closely to the chloride in its properties, and on heating sublimes in the form of white needles.

Zinc Iodide, ZnI₂. Zinc and iodine readily unite when they are heated together to form a colourless easily fusible mass, which sublimes in four-sided needles. An aqueous solution can be easily obtained by warming metallic zinc and iodine together with water. On evaporating the solution, the anhydrous compound separates out in the form of regular octohedrons, which when exposed to the air first absorb water and deliquesce, and then take up oxygen and liberate iodine.

154 *Zinc Sulphate, ZnSO₄.* This salt, long known under the name of white vitriol, is thus described by Basil Valentine in the first book of his *Last Testament*—"Behold the ∇ (water) of Goslar, how a fine white and red vitriol is found there." The name vitriol was applied to all the salts of the common metals possessing a vitreous lustre,¹ and to this day iron sulphate is known as green vitriol, and copper sulphate as blue vitriol.

White vitriol was prepared on the large scale at Goslar, in the Harz, in the sixteenth century. It was obtained by lixiviating the roasted ore, but its composition remained long unknown. Thus, in Lemery's *Cours de Chymie*, published in 1675, we read, "Le vitriol blanc est le plus dépuré de substance métallique." It was, indeed, soon discovered that this salt might be obtained by dissolving calamine in sulphuric acid, but as this ore always contains iron, green vitriol was obtained at the same time. In addition to this, the fact that both green vitriol and blue vitriol when heated become white through loss of water of crystallization led to still further confusion between these compounds. It was not until 1735 that Neumann suggested that the base of white vitriol consisted of zinc or calamine, and this view was confirmed by Hellot, inasmuch as he obtained the salt by dissolving zinc in dilute sulphuric acid, whilst Brandt showed that brass is obtained from white vitriol by calcining it and heating it with charcoal and copper.

Zinc sulphate occurs not unfrequently in zinc mines, where it is formed by the oxidation of blende. It is, however, usually obtained on the large scale by roasting ores containing sulphide

¹ "Atramentum candidum potissimum stiracis figura reperitur Goslarie, translucidum cristalli instar; nec cremulæ nec viride caret perspicuitate; unde superior ætas atramento sutorie vitrioli nomen imposuit."—AGRICOLA, *De Natura Fossilium*, Lib. III. ed. 1657.

of zinc, afterwards exhausting with water, and evaporating the solution to the crystallizing point, when the hydrate $ZnSO_4 + 7H_2O$, isomorphous with epsom salt, separates out. These crystals (Figs. 81 and 82) on heating fuse readily in the water of crystallization. Commercial zinc vitriol is made to

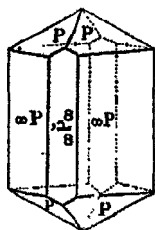

FIG. 81.

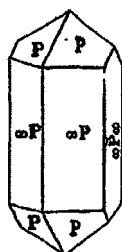
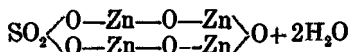

FIG. 82.

assume the shape of a sugar-loaf by stirring this fused mass in wooden troughs with wooden shovels till crystallization takes place, and subsequently pressing the mass into moulds. Its specific gravity is 1.95; it effloresces slowly in the air, and on heating to 100° loses six molecules of water, the last molecule being evolved only at a moderate red-heat. The anhydrous salt forms

a friable mass having a specific gravity of 3.4. When heated more strongly, sulphur dioxide and oxygen are evolved, and a basic salt remains behind, which is also formed when zinc sulphate and zinc oxide are boiled together. On cooling the hot saturated solution, glistening scales separate out having the formula:—



At a white heat all the zinc sulphates are completely decomposed, leaving a residue of zinc oxide. When a solution of white vitriol is evaporated above 50° the hydrate $ZnSO_4 + 6H_2O$ isomorphous with the corresponding magnesium salt separates out. Besides these, several other hydrated and basic zinc sulphates are known. One hundred parts of water dissolve:—

At	0°	20°	50°	75°
$ZnSO_4$	41.3	53.0	66.9	80.4.

Zinc sulphate is employed in medicine and in dyeing.

Zinc Nitrate, $Zn(NO_3)_2 + 6H_2O$. This salt crystallizes from a very concentrated solution of zinc in nitric acid, in striated colourless pointed four-sided prisms. These are very deliquescent, and are soluble in alcohol. When heated for some time to 100° , the salt loses water and nitric acid and a basic nitrate

remains, which is also formed by boiling the solution with zinc oxide.

Carbonates of Zinc. *Normal Zinc Carbonate*, $ZnCO_3$, occurs as zinc-spar or calamine, crystallizing in rhombohedrons, having a specific gravity of 4.42. Zinc-spar is found sometimes in the pure state, but in general, more or less of the zinc is found to be replaced by magnesium, cadmium, iron, and other isomorphous metals. When a solution of zinc vitriol is precipitated by an excess of hydrogen potassium carbonate, a white precipitate of the hydrated normal carbonate is obtained. If, on the other hand, normal sodium carbonate be employed, hydrated basic zinc carbonates possessing a variable composition are thrown down which become more basic the higher the temperature at which they are precipitated, and as the quantity of water is increased.

Cyanide of Zinc, $Zn(CN)_2$, is a snow-white powder used in medicine, and prepared by precipitating zinc acetate with aqueous hydrocyanic acid. It is insoluble in water and in alcohol, but dissolves in solutions of the cyanides of ammonium or potassium.

155 *Zinc Sulphide*, ZnS , is found as blende, which crystallizes in the regular system, frequently in hemihedral forms. Its specific gravity varies from 3.5 to 4.2. In the pure state it is transparent, and has a light yellow colour; usually, however, it contains iron and other metals which impart to it a red, brown, or black tint. The same compound is more rarely found as wurtzite in hexagonal crystals. When ammonium sulphide is added to a solution of zinc salt, a white amorphous precipitate of zinc sulphide is formed; this is soluble in dilute acids, with the exception of acetic acid, with evolution of hydrogen. When this precipitate is heated in a current of hydrogen, or when zinc oxide is ignited in an atmosphere of sulphuretted hydrogen, zinc sulphide is obtained in crystals which have the form of wurtzite.

Zinc Penta-sulphide, ZnS_5 , is formed when potassium penta-sulphide is added to a neutral solution of a zinc salt. It forms a white precipitate which becomes of a straw-yellow colour on drying, when ignited in absence of air it is converted into the monosulphide and sulphur. (Schiff.)

Zincamide or Zinc Diamine, $Zn(NH_2)_2$, is formed by the action of dry ammonia on zinc ethyl:

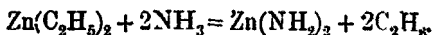

H²S

It is a white amorphous powder decomposed by water with evolution of heat :

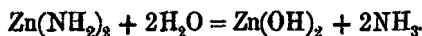

Zinc Nitride, Zn_3N_2 , is formed when zincamide is heated to dull redness :



It is a green powder which is decomposed by water with such energy that the mass when moistened becomes incandescent :

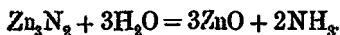

Zinc Phosphide, Zn_3P_2 , is obtained as a grey mass by heating finely divided zinc in the vapour of phosphorus (Schrötter). When zinc is heated in a current of hydrogen until it begins to melt, and then phosphorus vapour passed over it, together with hydrogen, a fused mass, having a bright metallic bismuth-like lustre, is obtained. Zinc phosphide is employed in medicine.

DETECTION AND ESTIMATION OF ZINC.

156 The salts of zinc do not impart to the non-luminous gas-flame any tint. The spark-spectrum of zinc is, however, characteristic, and can be well shown by volatilizing a small piece of the metal in the lower carbon pole of the electric lamp. Amongst the more prominent zinc lines are 6362 and 6099 in the red, and 4928, 4924, 4911 in the blue.

The most characteristic compound of zinc is the white sulphide insoluble in water and in the alkalis. In the ordinary course of qualitative analysis zinc is thrown down together with the other metals precipitated by ammonium sulphide, such as cobalt, nickel, iron, manganese, chromium, and aluminium; the first four are precipitated as sulphides, the two latter as hydroxides. The precipitate, having been well washed, is dissolved in dilute hydrochloric acid, and free sulphuretted hydrogen destroyed by heating with a little potassium chlorate. An excess of pure caustic soda is then added, and this throws down the first four metals, whilst the hydroxides of zinc, chromium, and aluminium remain in solution. In presence of chromium the solution possesses a green colour, and, on boiling, the hydroxide is completely precipitated, and the filtrate which is now colourless can be tested for zinc by passing a current of sulphuretted hydrogen through the liquid after slight acidification

with acetic acid. When a zinc compound is ignited on charcoal before the blowpipe and the heated mass moistened with a solution of nitrate of cobalt and again ignited, a beautiful green mass, known as Rinnman's green, is obtained. Zinc compounds heated in the blowpipe flame on charcoal with carbonate of sodium yield an incrustation of zinc oxide, which when hot is yellow, but on cooling becomes white.

Small traces of zinc can be readily and accurately detected by *Bunsen's method of flame-reactions*. This depends upon the fact that the more volatile metals, such as zinc, mercury, and arsenic, are reduced from their compounds when these are heated on a thread of asbestos held in the upper reducing-flame of the Bunsen burner. If a small porcelain basin, filled with cold water, be held just above the substance to be examined, the volatilized metal condenses on the outside of the cold basin as a metallic film, and in a few seconds the reaction is complete. A square centimeter of filter-paper is now moistened with nitric acid, and this rubbed over the surface of the basin so as to dissolve the oxide film; the paper is now rolled up and placed in a coil of thin platinum wire, and burned in the upper oxidizing-flame at as low a temperature as possible, when the colour of the ash is seen to be yellow when hot, but white on cooling. The ash is next moistened with a drop of a dilute cobalt solution, and heated in the flame, when the mass attains a green colour.

For the quantitative determination of zinc, the solution is precipitated with a boiling solution of sodium carbonate, the basic carbonate washed and dried and converted by ignition into zinc oxide, which is then weighed.

The atomic weight of zinc has been most accurately determined by Erdmann,¹ by oxidising pure zinc and weighing the oxide obtained.

CADMIUM. Cd = 111.6. Vapour Density = 55.8.

157 This metal was discovered in the year 1817 by Strömeier. He observed that a sample of zinc carbonate obtained from the zinc-works at Salzgitter yielded an oxide which, although it did not contain any iron, possessed a yellow colour, and he found that this was due to the presence of the oxide of a

¹ *Ann. Chem. Pharm.* 1 435.

new metal, which he soon afterwards detected in other samples of the oxide of zinc, as well as in metallic zinc itself. Whilst Stromeyer was engaged on these experiments, Hermann, in Schönebeck, also discovered the new metal in a sample of zinc oxide which was employed for pharmaceutical purposes, and which had been confiscated in Magdeburg, inasmuch as the acid solution yielded a yellow precipitate with sulphuretted hydrogen, which was supposed to be caused by the presence of arsenic. Hermann showed that this supposition was not correct, and ascertained that a new metal was present. Soon afterwards Meissner and Karsten also observed the existence of the same substance. In 1818 Stromeyer published a complete investigation of the metal, giving to it the name which it now bears, from *cadmia fornacum*, because the metal was chiefly found in the zinc flowers of the zinc furnaces.

Cadmium not only occurs mixed with zinc ores, but likewise as a sulphide in the mineral greenockite, a somewhat rare substance found at Bishopstoun and Kilpatrick in Scotland, as well as in Bohemia and Pennsylvania. The quantity of cadmium contained in the various samples of calamine and blende varies considerably. The fibrous blende found at Příbram in Bohemia contains 2 to 3 per cent., whilst the calamine of Wiesloch contains 1.6 per cent., and that of Eaton in North America 3 per cent. of cadmium.

In the process of zinc-smelting the more volatile vapour of cadmium comes off with the first portions of the zinc, and these vapours burn in the air with formation of the oxides of cadmium and zinc. The powder thus deposited is then mixed with coal and the mixture heated in iron tubes, when the cadmium distils over first. In order to purify it, the metal is redistilled, and the second product dissolved in hydrochloric acid, from which solution the cadmium is precipitated by metallic zinc.

Cadmium possesses a tin-white colour and a fibrous fracture, and takes a high polish. It can be easily crystallized in regular octohedrons by sublimation in a current of hydrogen (Kämmerer). It is somewhat harder than tin, but may be cut with a knife. It can be easily rolled out to foil and drawn into wire. When bent, it emits a crackling sound, as tin does when similarly treated. The specific gravity of the cast metal is 8.546, but after hammering it attains a specific gravity of 8.667 (Schröder). According to Rudberg it melts at 320°, whilst according to Wood its melting point is 315°, and its boiling

point 860°. Its vapour has a dark yellow colour and a disagreeable smell, producing headache when inhaled. The density of cadmium vapour as determined by experiments at 1040° by Deville and Troost is 3·94.¹

The yellow sulphide is employed as a pigment, and an amalgam of cadmium is employed as stopping for teeth, this being soft when first prepared but soon hardening.

Cadmium Oxide, CdO. This substance forms the brown blaze of the zinc smelters. The metal cadmium burns with a bright flame when heated in the air, forming a brown oxide, which may also be obtained by passing a mixture of steam and cadmium vapour through a red-hot tube. When the metal is heated to whiteness in a current of oxygen, the oxide sublimes in dark red, probably cubic, crystals, and may be obtained in the form of a dark blue-black powder, consisting of microscopic octohedrons, by igniting the nitrate. Cadmium oxide possesses a specific gravity of 6·5; it does not melt at a white-heat, but is easily reduced at a moderate red-heat on charcoal before the blowpipe; the metal, however, volatilizes and burns, and the oxide is deposited as a brown incrustation on the charcoal.

Cadmium Hydroxide, Cd(OH)₂, is obtained as a white precipitate on the addition of a soluble salt of cadmium to caustic potash. The hydroxide absorbs carbon dioxide from the air, and at 300° it is resolved into the oxide and water.

SALTS OF CADMIUM.

158 Cadmium salts are usually colourless. The soluble salts possess a disagreeable metallic taste, and act as emetics.

Cadmium Chloride, CdCl₂. This salt is obtained by evaporating a solution of the metal or oxide in hydrochloric acid. The hydrated chloride, CdCl₂+2H₂O, is deposited in the form of rectangular prisms which readily effloresce on exposure to the air, and on heating lose water and melt at a temperature below a red-heat. The transparent pearly mass of the anhydrous chloride sublimes at a higher temperature in transparent micaceous laminæ. Its specific gravity is 3·265. One hundred parts of water dissolve (Kremers):—

At	20°	40°	60°	80°	100°
CdCl ₂	140·8	138·9	138·9	142·9	142·9

¹ *Comptes Rendus*, xlix. 239.

Cadmium Iodide, CdI_2 , is obtained by dissolving the metal in hydriodic acid, or by digesting it with iodine and water. It crystallizes in large transparent six-sided tables, which do not undergo alteration on exposure to the air. It melts easily, solidifying again to a crystalline mass, but gives off iodine when heated to a higher temperature. It dissolves readily in water and alcohol. Its specific gravity is 4.576. One hundred parts of water dissolve :—

At	20°	60°	100°
CdI_2	92.6	107.5	133.3.

Iodide of cadmium is used in photography, it being one of the few iodides soluble in alcohol.

Cadmium Sulphate, CdSO_4 . A concentrated solution of sulphate of cadmium when allowed to evaporate spontaneously deposits large monoclinic hydrated crystals, having the composition $3\text{CdSO}_4 + 8\text{H}_2\text{O}$. A boiling saturated solution of the normal salt to which strong sulphuric acid has been added deposits indistinct crystals of $\text{CdSO}_4 + \text{H}_2\text{O}$. The normal salt when heated yields a basic compound, $\text{SO}_2 \left\{ \begin{array}{l} \text{OCd}(\text{OH}), \\ \text{OCd}(\text{OH}) \end{array} \right.$ difficultly soluble in water, and crystallizing in pearly scales. One hundred parts of water at 23° dissolve 59 parts of the anhydrous normal salt, and at the boiling point a somewhat larger quantity. Crystallized cadmium sulphate is used in diseases of the eye.

Cadmium Nitrate, $\text{Cd}(\text{NO}_3)_2 + 4\text{H}_2\text{O}$, crystallizes in fibrous needles, which deliquesce in the air, and are soluble in alcohol.

Cadmium Carbonates. The normal salt is not known. The white precipitate obtained by addition of the carbonate of an alkali to a soluble cadmium salt possesses a varying composition, according to the temperature at which the precipitation takes place and the amount of precipitant employed. With an excess of potassium carbonate in the cold the precipitate nearly possesses the composition of the normal salt.

Cadmium Sulphide, CdS . Cadmium sulphide occurs in yellow hexagonal glittering crystals as greenockite. It is obtained as a fine yellow precipitate when a cadmium salt is precipitated with sulphuretted hydrogen. It melts at a white heat, and forms on cooling a lemon-yellow micaceous mass, having a specific gravity of 4.86. It is soluble in strong hydrochloric and nitric acids, and in boiling dilute sulphuric

acid. When a cadmium salt is precipitated with potassium pentasulphide a yellow precipitate of cadmium pentasulphide CdS_5 is obtained.

DETECTION AND ESTIMATION OF CADMIUM.

159 Cadmium salts do not impart to the non-luminous gas-flame any tint. The cadmium spectrum is well seen when the metal is volatilized in the electric arc; the most prominent lines being 6438 in the red, 5378 and 5338 in the green, and 5085, 4800 and 4677 in the blue.

The yellow sulphide of cadmium is the most characteristic compound of the metal. This is insoluble in dilute acids in the cold, and hence may be easily distinguished from zinc as well as from the other metals already described. Cadmium sulphide can easily be distinguished from other yellow sulphides, such as those of tin, antimony, and arsenic by its insolubility in ammonium sulphide and in the caustic alkalis. The method of separating cadmium from the other metals precipitated by sulphuretted hydrogen will be discussed under these several metals. It may suffice here to remark that cadmium hydroxide, like the corresponding copper compound, is soluble in ammonia, and that these two metals are frequently obtained together in the process of analysis. In order to separate these, two methods may be employed. In the first place potassium cyanide may be added to the blue ammoniacal solution until this becomes colourless, and then sulphuretted hydrogen is led through the solution, when the cadmium sulphide is completely precipitated. Or, in the second place, the metals may be both precipitated as sulphides, and the washed precipitate boiled with a mixture of 5 parts of water and 1 part of concentrated sulphuric acid when the cadmium sulphide is dissolved out.

The quantitative determination of cadmium is usually made by precipitating the carbonate from the boiling solution with carbonate of soda; this is then dried and on ignition converted into the oxide which is weighed. Cadmium may also be determined as the sulphide which is dried at 100° and then weighed.

The atomic weight of cadmium has been determined by von Hauer, by converting the sulphate into sulphide in a current of heated and pure sulphuretted hydrogen.¹

¹ *Wien Acad. Ber.* xxv. 118.

METALS OF THE LEAD GROUP.

Lead. Thallium.

160 The metals of this group are soft, and possess a high specific gravity, and their basic oxides have an alkaline reaction. In many of its properties thallium closely resembles the alkali-metals, whilst lead, in many respects, is analogous to the metals of the alkaline earths. They are, however, distinguished from both of these groups, by their sulphides being black and insoluble in water, and also by the sparingly soluble character of their chlorides.

LEAD.

Pb (Plumbum) = 206.4.

The first mention of lead occurs in the well-known passage in the Book of Job, and it is also mentioned in the Book of Numbers as a portion of the 'spoil taken from the Midianites. It is found under the name of óphéret, derived from the word áphar, signifying to have a grey appearance. In the oldest Greek translations of the Old Testament the word μόλιβος occurs and this as well as the word μόλυβδος undoubtedly refers to lead. It appears, however, that no exact distinction was drawn between the metals lead and tin during the time of the Israelites. But we find that Pliny points out a distinction between these two metals, inasmuch as he gave the name of *plumbum nigrum* to lead, whilst tin was designated as *plumbum candidum*. For further information on this point the chapter on tin must be consulted.

It has already been stated (Vol. I., p. 87) that the seven metals known to the ancients were supposed to be in some way

connected with the seven heavenly bodies which were then known to belong to our solar system. Dull, heavy lead was apportioned to Saturn; and this metal is designated in the writings of the alchemists by the sign h .

Lead is seldom found in the free state in nature. Native lead does, however, occur in small quantities in certain lead ores, and in volcanic tufa. The oxides of lead are found in the form of rare minerals, the yellow oxide PbO , and the red oxide or red lead, Pb_3O_4 . The commonest ore of lead is galena or lead sulphide, PbS ; this is very widely distributed, generally occurring together with quartz, calc-spar, fluor-spar, and heavy-spar in the older as well as in the more recent strata and in almost every part of the world. Thus in Cornwall it occurs in veins in the coarse argillaceous schist, provincially termed killas; in Derbyshire, Cumberland, Northumberland, and Yorkshire, it is found in mountain limestone; in Cardiganshire and Montgomeryshire it occurs in the Lower Silurian; and the chief deposits in the United States likewise occur in this same formation. Again, at Sala in Sweden, it is found in granular limestone, and in Freiberg in a schistose gneiss, older than the carboniferous system. Sulphide of lead also occurs in combination with the sulphides of antimony and copper in the minerals zinckenite, PbSb_2S_6 , and bournonite, CuPbSbS_3 . In addition to these ores, lead carbonate occurs as the mineral cerussite, PbCO_3 , found in some localities, as in the neighbourhood of Aix-la-Chapelle, and of Santander in Spain, in sufficient quantity to be worked. It is also found in the lead mines of Cornwall and Devonshire, in Yorkshire, at Leadhills in Scotland, and at Seven Churches in County Wicklow. Other naturally occurring compounds of lead are the basic chloride occurring as the minerals matlockite, $\text{Pb}_2\text{Cl}_2\text{O}$, and mendipite, $\text{Pb}_3\text{Cl}_2\text{O}_2$; and sulphate of lead or anglesite, PbSO_4 , found associated with galena and carbonate of lead at Leadhills in Scotland and in other localities. Again we have a basic sulphate called lanarkite, $\text{PbO} + \text{PbSO}_4$; leadhillite, $\text{PbSO}_4 + 3\text{PbCO}_3$; phosgenite, $\text{PbCl}_2 + \text{PbCO}_3$; stolzite or lead tungstate, PbWO_4 ; wulfenite or lead molybdate, PbMoO_4 ; crocoisite or lead chromate, PbCrO_4 ; pyromorphite or lead phosphatochloride, $3\text{Pb}_3\text{F}_2\text{O}_8 + \text{PbCl}_2$; mimetesite or lead chloro-arsenate, $3\text{Pb}_3\text{As}_2\text{O}_8 + \text{PbCl}_2$; as well as compounds of lead with the rarer elements such as selenium, tellurium, selenic acid, vanadic acid, &c.

By far the greater proportion of the total lead brought into the markets of the world, amounting annually to about 300,000 tons, is obtained from galena.

161 *Smelting of Lead*.—Lead is an easily reducible metal requiring but simple processes for its production. Lead was produced in England during the Roman occupation in a variety of localities. Numerous pigs of Roman lead have been found bearing Latin inscriptions. Whether lead was reduced in England before this period appears doubtful; the remains of rude furnaces in which lead ore was smelted in early times are, however, found in Derbyshire and elsewhere, and are termed *boles* by the inhabitants. In these furnaces the heat was not urged by an artificial blast of air, but piles of stone were built on the western brow of some eminence: so as thus to employ the natural currents of air on mountainous places. A mixture of ore and charcoal was introduced into the interior of these furnaces, and after the operation the lead ran out at the bottom.

The form of furnace next employed was the *ore-hearth*, a small rectangular blast furnace blown by bellows worked by means of a water-wheel.¹ This furnace is still in use and will be hereafter described. Other and larger blast-furnaces are in use in various lead-smelting districts.

About the middle of the eighteenth century lead smelting in reverberatory furnaces appears to have been introduced into England from Flintshire, where it was in use in the year 1698.

Three distinct processes are employed for lead smelting. The first of these, known as the *air reduction process* (Percy), is employed when the ore consists mainly of galena, and is free from silica and the sulphides of other metals. The second, or *carbon reduction process*, is employed for less pure ores, and consists in the roasting of the ore and the subsequent reduction of the lead by carbonaceous matter. The third process is known as the *precipitation process*, the reduction of the lead being effected by metallic iron, and this is chiefly practised in France and Germany, where the ore contains other metals, such as copper, antimony, and arsenic.

It is, however, to be remembered that two or even all three of the above processes are often worked in the same furnace with the same charge of ore.

¹ See H. L. Pattinson, "Description of Lead Smelting in the North of England." *Transactions of the Natural History Society of Northumberland, Durham, and Newcastle-on-Tyne*, vol. ii. part i.

Lead smelting according to any one of these processes is conducted in three kinds of apparatus, viz., (1) reverberatory furnaces, (2) blast furnaces, (3) shallow hearths.

In the *air reduction process* the galena is roasted in a reverberatory furnace until a portion of the sulphide is converted into oxide and sulphate; the temperature is then raised when the following double decompositions take place :

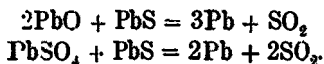

The reverberatory furnaces used for the English process of lead smelting are of two kinds, the Flintshire furnace and the flowing furnace. The difference between these is that in the first the slag is raked out in pasty lumps, whereas in the flowing furnace the slag is tapped out in the molten state and termed

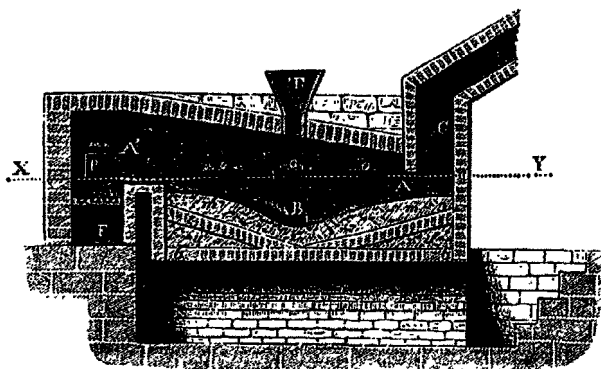

FIG. 83.

run-slag. The reaction which takes place in reduction is identical in both cases.

Fig. 83 shows the construction of the Flintshire furnace. The usual charge of ore is 20 cwt. This is introduced by means of a hopper (T) in the arch of the furnace. The hearth of the furnace (B) is hollowed out as shown in the figure to permit the lead to flow through a tapping hole, into an iron pot placed in front of the furnace. The charge is evenly spread over the surface and gently heated for two hours, the ore being well rabbled at intervals, and the temperature being carefully regulated by opening or closing the various doors, so

as to maintain the mass as hot as is possible without causing it to clot together. During this process a portion of the sulphide is oxidised to oxide and sulphate, and thus the mass prepared for the following stage of the operation. The second reaction, in which the reduction of the lead takes place, is brought about by increasing the temperature of the roasted ore; the lead is reduced as shown in the above equations, and flows down to the tap-hole and is drawn off at the end of the process. The undecomposed sulphide remains

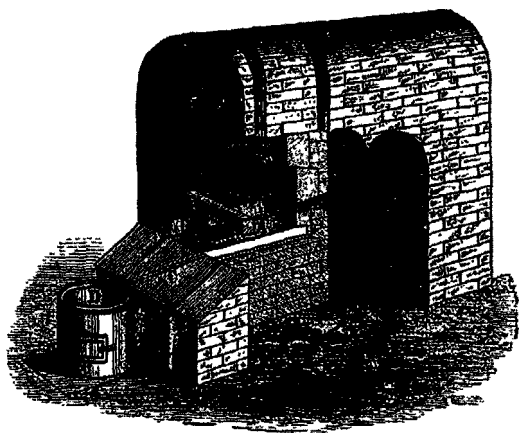

FIG. 84.

behind and this is oxidised by a second firing; the temperature is then again raised when the double decomposition is repeated, and thus the alternate processes of roasting and smelting are carried on as long as any lead can be extracted. Before the temperature is raised in each case a shovelful of lime is thrown in through the door to stiffen the fused mass. After tapping the metal the *grey slag* is withdrawn at the back of the furnace.

A similar method is adopted at Bleiberg in Carinthia for working the calcareous galena, a different form of furnace being, however, employed. This furnace is very much smaller than either of the English lead furnaces and only 300 lbs. of ore are worked at once, the object being to conduct the work with

accuracy and precision, the small quantity worked upon placing the calcination process better under command. As soon as the charge is placed on the floor of the furnace it is heated to dull redness, and the roasting is completed in from three to four hours. This constitutes the first stage of the process, in which the sulphide is partially converted into oxide and sulphate of lead. As in the English process, the temperature is now raised and the double decomposition between the oxidised products and the undecomposed sulphide, which has already been described, takes place. The reduction of the lead appears to go on in this process at a lower temperature than in the working of the English process, and the virgin lead (*Jungferblei*) thus obtained is believed to be purer than the lead obtained in the Flintshire furnace. This is especially the case in Bleiberg, as well as in certain Belgian works, where considerable impurities are contained in the lead ore. The impurities remain behind in the slag whilst the lead is run off in the pure state.

In Scotland and the north of England, where a very pure ore is worked, lead smelting is conducted in shallow hearths or Scotch furnaces shown in Fig. 84. The hearth (A) is first filled with peat which is then ignited, and ore added from time to time in quantities of about a dozen pounds weight, the temperature being kept up by a blast of air sent in at the back of the furnace. The reduced lead sinks down to the bottom and flows out along the channel in the *work-stone* (C) into the heated pot (D). A considerable amount of lead is volatilised as fume in this process: this passes through the flue (B) to long collecting chambers in which it is deposited. The lead thus obtained is said to be purer than that prepared in the Flintshire furnace, but the cost of smelting in this ore-hearth is greater than when the Welsh method is used.

For the reduction of impure ores or for the working up of slags from the other processes a *slag-hearth* or a small blast-furnace (Fig. 85) is used, of about 0.5 metre in height, containing a square space (C), the sides of which are built of iron plates. The blast of air enters by the tuyere (T), and the reduced metal runs through a hole in the plate into the vessel (M). The hearth is filled with fuel and the ore thrown on to the top of the fuel. The ore is at first converted into a mixture of sulphate and oxide, and these undergo mutual decomposition with evolution of sulphur dioxide as they descend to the

lower portion of the hearth, where the temperature is higher. A somewhat similar treatment of washed lead ores by metallic iron in blast furnaces is adopted at Pongibaut, in Puy-de-Dôme, and of siliceous ores at Couëron.

162 *Smelting of Lead Ores with Metallic Iron.*—The process by double decomposition is certainly the simplest method of lead smelting. It can, however, be only employed in case of ores which do not contain the sulphides of other metals. For ores such as those which occur in the Harz, where the galena

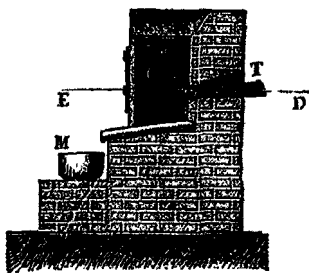

FIG. 85.

is mixed with iron pyrites, copper pyrites, zinc blende, fahl-ore, bournonite, and zinckenite, the third or precipitation process has to be adopted, and is carried on in the so-called schlieg furnace. In this process cast-iron is used as the reducing agent, less being added than would suffice according to theory for the complete reduction of the galena in the ore. At the present time in

place of cast-iron a rich iron slag is used for the same purpose. The materials to be smelted together are brought successively layer upon layer into a blast furnace having one or more tuyeres. In this process a portion of the lead is reduced by the metallic iron, a considerable residue, however remaining behind, in the form of sulphide, together with the sulphides of iron and the other metals which are contained in the ore. To this the name of schlieg-slag or lead regulus is given, and this material is then worked up again by processes varying according to the nature of the metals which have to be extracted. Thus, for instance, if the lead slag contains much copper it is roasted and smelted, and these operations repeated until it becomes so rich in copper that it can be worked by the ordinary copper smelting processes.

Softening of Lead. The metal produced in some of the foregoing processes is hard, owing to its containing antimony and other metals. These are removed and the lead rendered soft by melting and partially oxidising the metal in a reverberatory furnace with a cast-iron bottom.

163 *Desilverisation.*—Ordinary lead obtained by any of the

above-mentioned processes always contains silver, and a very considerable proportion of the silver which now comes into the market is obtained from argentiferous galena. In former times the only process by which this silver could be extracted was by the process of cupellation, by which the whole of the lead is oxidised, whilst metallic silver remains behind. The oxide has then to be reduced again in a reverberatory furnace to metallic lead. It is, however, generally admitted that the process of cupellation cannot be economically carried on in the case of lead which contains less than 8 oz. of silver to the ton, and consequently, as very large quantities of lead are brought into the market containing smaller percentages than this, the whole of this amount of silver was lost until Mr. Hugh Lee Pattinson, in the year 1833 obtained a patent for an improved method of separating silver from lead, which has come into general use, and by which large quantities of silver are now extracted from lead.

This method depends upon the fact that if lead containing a small quantity of silver be melted, and the melted mass allowed to cool, a point is reached at which pure lead begins to crystallise out. If the crystals of lead which are thus formed be then withdrawn from the remainder of the metal, and this process continued until the greater part of the lead has been separated, it is found that the liquid which remains contains most of the silver. In order to render this process economical the lead requires to be repeatedly crystallised in a series of iron pots, the lead rich in silver gradually accumulating towards one end of the series, whilst the desilverised or market lead is obtained at the other end.

The melted lead is first thoroughly skimmed, then the fire is withdrawn and the lead allowed to cool care being taken to break off and mix with the liquid mass any portion that may solidify on the sides of the pot. When the temperature reaches a certain point, small crystals of lead begin to form, and at this point the whole mass of metal is continually stirred with an iron rod, whereby the crystals sink to the bottom of the pot and accumulate in considerable quantity. A perforated ladle is now introduced by means of which the crystals are removed. The operation is thus carried on in successive stages until two-thirds or even three-fourths of the original lead is removed from the pot. By this means in an actual working 846 cwt. of original lead was separated into 36 cwt. of rich lead containing 160 to 170

ounces of silver per ton, and 810 cwt. of poor lead containing 7 to 10 dwt. of silver per ton. The silver is then extracted from the rich lead by the process of cupellation. (For a description of this process see Silver.)

Another process for desilverising lead is known as Parkes's or Karsten's zinc process. It has already been mentioned in the chapter on alloys that molten lead and zinc do not mix in all proportions, lead being capable of taking up only 1·6 per cent. of zinc whilst zinc takes up only 12 per cent. of lead. Karsten, in 1842, concluded from experiments which he made on the subject that lead gives up all the silver which it contains if melted with zinc, but he did not apply this conclusion to practical metallurgy. In the year 1850, Alexander Parkes, of Birmingham, patented a process for extracting silver from lead by the above-mentioned reaction. For a ton of lead containing 14 oz. of silver, 22·4 lbs. of zinc is needed; if containing 21 oz., 33·6 lbs. of zinc is added, and if containing 28 oz. of silver, 44·8 lbs. of zinc is required. The alloy of zinc and silver rises to the surface during cooling, and when it solidifies it is withdrawn by means of a perforated ladle. In order to remove the small quantity of zinc which is dissolved in the pure lead, the mixture is heated to dull redness in a current of air, the zinc thereby being oxidised, whilst the main portion of the lead remains behind in the marketable state. Silver is separated from the alloy of zinc either by distilling off the zinc or by dissolving the zinc in acid. A second process employed for the dezincification of the desilverised lead is that patented by Cordurié in Toulouse in 1866. It depends upon the fact that when superheated steam is passed into the molten alloy of lead and zinc, the zinc is oxidised together with a small portion of the lead, the oxides being carried away into chambers where they are condensed, whilst the desilverised lead remains behind in the pure state.

Gold and copper, which sometimes occur in market lead, can be separated from it in the same way, inasmuch as these metals alloy with zinc even more readily than silver does, and this process has been satisfactorily carried out in England by Mr. Baker. A similar method is employed in the Harz; the lead is there melted with 0·16 per cent. of zinc, and the alloy is obtained as a scum on the surface, having the composition—

Lead	89·46
Zinc	5·78
Copper	4·52
Silver	0·243
	<hr/>
	100·003

On a second addition an alloy having the following composition is obtained :—

Lead	91·05
Zinc	5·21
Copper	3·50
Silver	0·238
	<hr/>
	99·998 ¹

Market lead almost always contains traces of antimony, copper, and iron, and occasionally of zinc, nickel, and bismuth, whilst the silver which it contains varies from one part in 40,000 to one part in 200,000, but since the introduction of the method of desilverising by zinc, and purification by steam the purity of the commercial lead has very much increased. An analysis by Hampe of a refined lead from the Harz, gave the following results :—

Antimony	0·0057 percent.
Copper	0·0014 „
Iron	0·0023 „
Zinc	0·0008 „
Nickel	0·0007 „
Bismuth	0·0055 „

showing a total impurity of only 0·0164 per cent.

164 *Chemically pure lead* is prepared according to Stas² as follows :—A solution of acetate of lead is heated in a leaden vessel in contact with thin sheet lead to a temperature of from 40° to 50° in order to precipitate silver and copper. The filtrate is then poured into pure, very dilute sulphuric acid, and the lead sulphate which is formed, carefully washed with a solution of carbonate of ammonia, and ammonia, lead carbonate being in this way formed. A portion of this is then converted into lead oxide

¹ Rammelsberg, *Ber. Entw. Chem. Ind.* 935.

² *Bull. Acad. Roy. Belg.* x. 294.

by carefully heating in a platinum basin, whilst to the remaining portion pure dilute nitric acid is added in such quantity that a portion of the carbonate remains undissolved. The oxide of lead is then added to the boiling solution of the nitrate in order to precipitate traces of iron, and the filtered solution is poured into a solution of pure carbonate of ammonia. The precipitated lead carbonate is then reduced by means of potassium cyanide, and the metal thus formed, fused a second time with the cyanide, when it assumes in the molten state a convex surface like mercury.

Lead can easily be obtained in the form of regular octahedrons by melting and allowing the molten metal partially to solidify, and pouring off the portion which is still liquid. If a piece of zinc be hung up in a solution of sugar of lead, lead separates out in bright shining arborescent forms, known as the lead tree. The deposition of lead in the form of crystals may be readily shown on the screen by means of a galvanic current. Lead has a specific gravity of 11.254, or after it has been poured into water of 11.363. On hammering it cracks and becomes lighter, but if it be pressed it attains a specific gravity of 11.388. It is soft and tough. It may be cut with a knife, and leaves a streak upon paper. It can easily be rolled out to thin foil, but it cannot be drawn out into fine wire. When melted repeatedly it becomes hard and brittle, which is probably due to the formation of a small quantity of oxide. On the large scale this oxide may be removed by poling or stirring the molten mass up with a pole of green wood. The presence of antimony, zinc, bismuth, arsenic, and silver increases the brittleness of lead. Lead belongs to the class of white metals, though it has a decidedly bluish grey tint indicated by the expression lead-grey. A freshly cut surface possesses a bright lustre, which, however, soon becomes dull from superficial oxidation. By the electrolysis of lead nitrate, Wöhler obtained a deposit on the negative pole of crystallised leaflets of lead possessing a red colour like that of copper. These did not dissolve in dilute acids whilst they were, soluble in hot nitric acid, and on dissolving, the colour resembled that of copper to the last moment.¹ Lead melts at 334° (Person), and begins to volatilise at a bright red heat, boiling rapidly before the oxyhydrogen blowpipe. It cannot, however, be distilled in closed vessels like zinc, although when zinc is extracted from ores containing lead, the vapour of

¹ *Ann. Chem. Pharm. Suppl.* Band ii. 135.

zinc is mixed with vapour of lead, and a considerable portion of the loss experienced in the ordinary processes of lead smelting is due to this cause.

Metallic lead is largely employed in the arts for a great variety of purposes on account of its softness and pliability, its low melting point, the difficulty with which it undergoes oxidation, and the fact that it withstands the action of water and of many acids better than most of the common metals.

LEAD AND OXYGEN.

165 *Lead Suboxide*, Pb_2O , is formed when lead oxalate is heated in an atmosphere free from oxygen to a temperature below 300° (Dulong):—

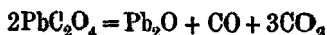

It is a black, velvety powder, which when heated in absence of air is decomposed into metal and the monoxide. When lead is melted in the air the surface becomes covered first with a grey film, which, according to Berzelius, consists of the suboxide. The suboxide has by some been considered to be an intimate mixture of finely divided lead and the monoxide. Against this view, however, is to be placed the fact that mercury does not dissolve metallic lead from this grey powder, whilst a solution of sugar which readily dissolves lead monoxide, does not take up any from this substance. After heating, dilute acetic acid or a solution of sugar does dissolve out lead oxide, whilst metallic lead remains behind in the coherent state.

Lead Monoxide, PbO .—This compound was known to the ancients, as it is formed when lead is heated in contact with the air, and is, therefore, produced in various metallurgical processes. The different forms of this compound were, however, regarded as different substances, giving rise to the names *plumbum ustum*, *scoria plumbi*, *scoria argenti*, *galena*, *μολύβδαινα*, *λιθάργυρος*, &c. When lead is heated to its point of volatilisation in the air, it takes fire and burns with a white light, yielding this oxide which formerly received the name of flowers of lead or *flores plumbi*. Lead, when heated in the air, becomes covered with a grey film, and if the surface be continually renewed, becomes wholly converted into lead-ash, a yellowish-grey pulverulent mixture of metallic lead and yellow monoxide, which, if heated in the air for a longer time, is wholly converted into the

latter. This yellow oxide is termed *massicot*, whilst the other form of lead monoxide termed *litharge*, is obtained at a temperature at which the oxide fuses, solidifying to a scaly shining mass sometimes of a yellow tint, sometimes rather inclined to red.

Crystallised oxide of lead also occurs in nature as a mineral found near Vera Cruz (Nöggerath). The crystals may also be artificially obtained by allowing litharge to cool slowly; it forms rhombic octohedrons sometimes also found as a deposit in the lead furnaces (Mitscherlich). Lead oxide possesses a colour varying from lemon-yellow to reddish-yellow, and on heating assumes a brownish-red tint. Its specific gravity at 4° is 9.36 (Joule and Playfair). It is reduced to the metallic state by carbonic oxide at 100°, and by hydrogen at 310°. Litharge is largely used in the arts, especially for the manufacture of flint-glass, and as a glaze for earthenware; it is also used for the preparation of red-lead, lead acetate, lead nitrate, white-lead, lead-plaister, and drying oils. Commercial litharge contains carbon dioxide and water absorbed from the air, which may be removed by ignition. Not unfrequently it contains small quantities of iron oxide and copper oxide, the latter easily removable by ammonia.

Basic Lead Hydroxide, $Pb_2O(OH)_2$ or $HO-Pb-O-Pb-OH$. This substance is obtained as a white precipitate by the action of air and water free from carbonic acid upon the metal, or is thrown down as a white precipitate on the addition of ammonia or a fixed alkali to a lead salt.

The compound $Pb_3O_2(OH)_2$ is formed according to Payen as follows 100 parts of a solution saturated at 16° of basic acetate of lead, $Pb_2O_2(C_2H_3O_2)_2$, are added to 50 volumes of cold water which has previously been well boiled: a mixture of 20 parts of ammonia and 30 parts of boiled water is then added and the solution allowed to stand at a temperature of 25–30° when the above hydrate separates out in glittering octohedrons.

At 130° lead hydroxide loses a portion, and at 145° the whole of its water, being then converted into lead oxide. The hydroxides of lead as well as the oxide turn moistened red litmus paper blue as they are somewhat soluble in water. They all act as strong bases and also combine with certain metallic oxides. Thus when lead oxide is fused with the alkalis, alkaline earths, and other metallic oxides, a glass is formed and in consequence of this lead oxide attacks clay crucibles. It dissolves also

in caustic potash and soda as well as in lime and baryta water yielding yellow liquids. The lime compound is slightly soluble in water and crystallises on cooling in white needles (Berthollet, Karsten).

Lead Sesquioxide, Pb_2O_3 , is formed when a solution of sodium hypochlorite is carefully added to a caustic potash solution of lead oxide (Winkelblech) or when a solution of red lead in acetic acid is precipitated by very dilute ammonia. It is a reddish yellow amorphous powder which does not part with the whole of its water at 150° . It is decomposed by acids into the monoxide and dioxide, and is, therefore, considered to be a compound of these two.

Red Lead or Minium, Pb_3O_4 .—This compound was described by Pliny, under the name of *minium*, but it was at that time not sufficiently distinguished from cinnabar and the red sulphide of arsenic. Dioscorides, however, mentions that it can be prepared from white lead: "*cerussa, si coquatur rufescit;*" and Geber says: "*plumbum aduritur et fit minium.*"

Red lead is usually prepared by carefully heating very finely divided pure massicot or white lead. For this purpose the oxide is heated for about twenty-four hours either on the flat hearth of a reverberatory furnace, or in barrel-shaped vessels open at both ends, the mass being frequently stirred and the heat not allowed to rise above dull redness. The brightness and beauty of the colour much depends on the care spent on the roasting, as these properties are not wholly influenced by the absorption of oxygen, but more especially by the molecular condition of the material and this is produced only at a given temperature.

Red lead is a scarlet crystalline granular powder, which, on heating, first assumes a finer red colour and afterwards turns violet and lastly black, but on cooling regains its original tint. On ignition it loses oxygen and is converted into the monoxide. Its specific gravity varies from 8.6 to 9.1. Commercial red lead frequently contains the yellow oxide litharge mixed with it, which may be extracted by repeatedly digesting it with a solution of lead acetate. Red lead is largely used as a paint and also in the preparation of flint-glass. For both of these purposes it is necessary that it should be as free as possible from iron, and in this case it is not unfrequently prepared from white lead. Red lead is also adulterated with oxide of iron, red bole, and brick-dust. These substances remain undissolved when red lead is digested in warm dilute nitric acid to which a little sugar

has been added. Boiling hydrochloric acid extracts sesquioxide of iron from the oxide with formation of lead chloride and liberation of chlorine.

166 Lead Dioxide or Puce-coloured Oxide of Lead, PbO_2 .—This substance was discovered by Scheele, who observed that red lead is coloured brown when treated with chlorine water, whilst Priestley found that nitric acid produced the same reaction. The properties of the puce-coloured lead oxide were more exactly examined by Proust and Vauquelin.

Lead peroxide, as the compound is frequently called, may be prepared according to a variety of methods. The simplest plan is by acting upon red lead with dilute nitric acid :

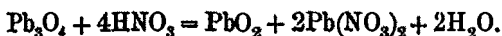

It is likewise obtained by the action of chlorine upon lead salts in the presence of alkalis (Wöhler), or by treating a solution of a pure lead salt with a soluble hypochlorite (Böttger):—

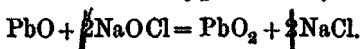

It is obtained in the dry way by fusing 4 parts of lead monoxide, 1 part of potassium chlorate, and 8 parts of nitre (Liebig and Wöhler). Lead oxide is also converted into the peroxide by the action of ozone as well as of hydrogen peroxide, and it is deposited in crystalline scales at the positive pole when a lead salt is decomposed by means of a galvanic current.

This substance is found native in the form of plattnerite, which crystallises in black six-sided prisms having a specific gravity of 9.4. The artificial peroxide sometimes occurs in the form of brownish-black six-sided tablets; generally, however, as a dark brown powder which has a specific gravity of 8.9 to 9.2.

Lead dioxide decomposes on heating into oxygen and the monoxide. It loses oxygen when simply exposed to sunlight, red lead being formed. It has a strongly oxidising action and when triturated with one-sixth of its weight of sulphur, it takes fire and burns with a brilliant flame, forming sulphide of lead.¹ Aqueous hypophosphorous acid is at once oxidised with formation of lead phosphate. When immersed in sulphurous acid gas at ordinary temperatures it becomes red-hot and is converted into lead sulphate whilst nitrogen peroxide and even ammonia, convert it into lead nitrate. A large number of organic acids and other carbon compounds when triturated with

¹ Vauquelin, *Ann. Chim. Phys.* lxi. 221.

it likewise cause evolution of light and heat. When treated with aqueous hydrochloric acid, chloride of lead and free chlorine are formed. Lead peroxide is often employed as an oxidising agent, as for instance, in the analysis of organic substances containing sulphur in order to separate the sulphur dioxide from carbon dioxide. The mixture of lead nitrate and peroxide obtained by treating red lead with nitric acid, is employed under the name of oxidised red lead in the manufacture of lucifer matches.

Lead peroxide acts in the presence of certain acids as a weak basic oxide. Thus, for instance, it dissolves in a tolerably concentrated solution of phosphoric acid, yielding a colourless strongly oxidising liquid which is decomposed on boiling, with evolution of oxygen. On the other hand it sometimes plays the part of an acid and the name *plumbates* has been given to the compounds obtained. The hydroxide or *plumbic acid*, $\text{PbO}(\text{OH})_2$, is deposited at the positive pole by the electrolysis of lead salts. It may also be prepared as a bluish-black shining body by the electrolysis of an alkaline solution of lead sodium tartrate.

Potassium Plumbate, $\text{K}_2\text{PbO}_3 + 2\text{H}_2\text{O}$, is obtained in the form of crystals according to Fremy,¹ by fusing lead peroxide with excess of caustic potash in a silver crucible, dissolving in water and evaporating in a vacuum. This solution gives a precipitate with most metallic salts of the corresponding plumbates. Calcium plumbate is also formed by heating a mixture of lead nitrate, lime, and bleaching powder for some time to a temperature of 57° (Crum).

Lead peroxide and red lead may also be considered to be salts of plumbic acid; the first is a normal and the second a basic salt:



SALTS OF LEAD.

167 *Lead Chloride*, PbCl_2 .—Dioscorides mentions that yellow oxide of lead when brought in contact with common salt and warm water becomes white. After the discovery of silver chloride, to which the name of horn-silver was given, the corresponding lead compound was termed horn-lead (*plumbum corneum*). Lead

¹ *Ann. Chim. Phys.* [3] xii. 490.

chloride occurs native in the craters of volcanoes as the mineral cotunnite.

Lead combines with chlorine, but slowly, and without incandescence. Dilute hydrochloric acid dissolves the metal only in the presence of the air, and then but slowly. The boiling concentrated acid, however, converts it into chloride with evolution of hydrogen gas. Lead chloride is easily prepared by the action of hydrochloric acid on the oxide or carbonate, and also by the precipitation of a tolerably concentrated solution of a lead salt by means of hydrochloric acid or a soluble chloride. It is thus obtained in the form of a white crystalline precipitate. At $12^{\circ}5$ it dissolves in 135, and at 100° in less than 30 parts of water, crystallising on cooling in rhombic white silky needles, which have a specific gravity of 5.8. Lead chloride does not dissolve in dilute hydrochloric acid, or in solutions of chlorides readily as in pure water, but it dissolves more freely in concentrated hydrochloric acid. Hence a precipitate is obtained on adding water to the latter solution, whilst the aqueous solution is precipitated by hydrochloric acid. It is insoluble in alcohol of 94 per cent., whilst in aqueous alcohol it dissolves only with difficulty, and to the greater extent the larger the proportion of water contained in it. The acetates and thiosulphates of the alkali metals dissolve it readily. When heated in absence of air, lead chloride melts below a red-heat and without volatilisation, solidifying on cooling to a white translucent horny mass. Ignited in contact with the air until no further vapours are seen, a basic chloride is formed, $PbCl_2 + PbO$ or $ClPb-O-PbCl$. This substance occurs naturally as the mineral matlockite. Another mineral, mendipite, has an analogous composition, viz., $PbCl_2 + 2PbO$ or $ClPb-O-Pb-O-PbCl$. A third basic lead chloride, $PbCl_2 + 3PbO$, may be obtained, according to Berzelius, by precipitating a solution of lead chloride with ammonia. This latter compound is also a hydrated oxychloride, and is likewise obtained by warming lead oxide with a solution of common salt (Schéele), caustic soda being at the same time produced. In the year 1787, Turner took out a patent for the purpose of preparing caustic soda by this reaction, and found that the residue when heated became anhydrous and possessed a yellow colour. This oxychloride is known under the name of *Turner's yellow* or *patent yellow*. Vanquelin then showed that when lead chloride and lead oxide are fused together a yellow coloured body is obtained. This is now known as *Cassel yellow*, and is usually prepared by fusing

together 1 part of sal-ammoniac with about 10 parts of massicot, minium, or white lead; a part of the sal-ammoniac sublimes undecomposed, and the resulting compound contains about 1 molecule of chloride to 7 molecules of oxide; part of the lead being at the same time reduced by the ammonia.

Oxychloride of lead is largely prepared for use in place of white lead, by a process patented by Mr. Pattinson in 1849. In this process chloride of lead is first prepared from finely pulverised galena and concentrated hydrochloric acid; this is then dissolved in water and mixed with lime-water in certain definite proportions; a snow-white precipitate having the composition $Pb(OH)Cl$, is thrown down, which from its covering power is largely used as a paint.

Lead Perchloride. This compound which has probably the composition $PbCl_4$, is obtained by dissolving the dioxide in strong, well-cooled hydrochloric acid; a yellow solution is thus obtained which possesses strong oxidising properties, and from which water and the alkalis precipitate the dioxide (Millon).

Lead Bromide, $PbBr_2$. This compound closely resembles the chloride. It is obtained by treating lead oxide with aqueous hydrobromic acid, or by precipitating a lead salt with a solution of potassium bromide, when it is thrown down in the form of white shining needles. It dissolves in hot water and has a specific gravity of 6.6. On heating in a closed vessel it fuses forming a red liquid which on cooling solidifies to a white horny mass. Fused in contact with the air it emits white fumes and leaves a residue of oxybromide, $PbOBr_2$, forming a pearly yellow mass.

Lead Iodide, PbI_2 . Hydriodic acid easily dissolves lead, and the iodide separates out from a concentrated solution in beautiful yellow crystals (Deville). When a solution of a lead salt is mixed with a soluble iodide a yellow precipitate of lead iodide is formed. This is soluble in 1235 parts of cold, and 194 parts of boiling water, giving rise to a colourless solution from which the iodide separates out on cooling in yellow laminae resembling those of Mosaic gold. The specific gravity of this compound is 6.1; on heating it becomes reddish yellow, then of a bright red colour, and lastly assumes a brownish black colour; it melts in a closed tube to a reddish brown liquid which solidifies to a yellow crystalline mass. Like the chloride and bromide it easily forms basic salts.

Lead Fluoride, PbF_2 . This compound is a white powder

obtained by heating lead oxide with hydrofluoric acid, or by precipitating a lead salt with a soluble fluoride. It is almost insoluble in water and in hydrofluoric acid, but readily soluble in hydrochloric and nitric acids. When treated with ammonia an easily soluble basic fluoride is formed. If a solution of chloride of lead is precipitated with sodium fluoride the compound $PbClF$ is formed. This chloro-fluoride of lead is slightly soluble in water, dissolving without decomposition (Berzelius).

Lead Chlorite, $Pb(ClO_2)_2$, is formed by precipitating neutral calcium chlorite with lead nitrate. It forms sulphur yellow crystalline scales which when heated to 100° decompose after some time with explosion.¹ When triturated by means of a glass rod with flowers of sulphur, the mixture at once takes fire.

168 *Lead Sulphate*, $PbSO_4$. This substance is found native as lead vitriol or anglesite in transparent rhombic crystals, isomorphous with those of celestine and heavy-spar, or as pseudomorph of galena. It is obtained as a white powder by precipitating a lead salt with sulphuric acid or a soluble sulphate. If a layer of water be poured on to a saturated solution of potassium sulphate, and a platinum wire on which some lead chloride has been fused allowed to dip into the water, crystals of lead sulphate are gradually formed.² Lead sulphate has a specific gravity of 6.2 to 6.3. It melts at a red-heat without decomposition. One part of the salt dissolves in 22,800 parts of cold water, and in 36,504 parts of dilute sulphuric acid (Fresenius), whilst concentrated sulphuric acid can take up about 6 per cent. of the compound. It also dissolves in warm ammonia and caustic potash, and in hot hydrochloric acid with formation of lead chloride. Sulphate of lead is likewise very readily soluble in ammoniacal salts, especially in the acetate; calcium acetate and many other salts also dissolve it.

If a plate of zinc be covered with a thick layer of a pasty mixture of lead sulphate and water, and this covered with another zinc plate, and the whole placed in a solution of common salt for ten days, a coherent mass of spongy lead is obtained which may be used for the purpose of obtaining impressions of various articles.

When lead sulphate is boiled with concentrated sulphuric acid, it is dissolved and is afterwards deposited in crystals, and if the

¹ Schiel, *Ann. Chem. Pharm.* cix. 321.

² Manross, *Ann. Chem. Pharm.* lxxxii. 360.

mother-liquor be allowed to stand in contact with moist air. crystals of the acid sulphate, $PbSO_4 + H_2SO_4 + H_2O$, similar to the corresponding barium salt, are formed.

When the normal salt is treated with ammonia, the basic sulphate Pb_2SO_4 or

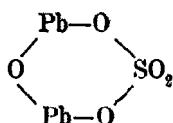

is formed. The same salt is obtained in microscopic needles when an excess of a hot solution of sodium sulphate is added to basic lead formate (Barford).

Lead Nitrate, $Pb(NO_3)_2$. Lead nitrate is first mentioned in the *Alchymia* of Libavins. It is here termed *calx plumbi dulcis*. "Fit per apuam fortem comminuto plumbo affusam vase in aqua frigida locato. Fit instar crystallorum." Lead dissolves slowly in warm dilute nitric acid. Lead nitrate, or lead saltpetre as it is sometimes called, is prepared on the large scale by dissolving lead-scale or litharge in hot dilute nitric acid, having a specific gravity of 1.35. The solution is evaporated until it attains a specific gravity of 1.6, and then is allowed to cool in earthenware vessels, when the salt separates out in milk-white regular octohedrons, exhibiting a combination of the regular dodecahedron. If a cold solution of the salt be allowed to undergo spontaneous evaporation, transparent octohedral crystals are formed (Knop). It has a specific gravity of 4.5, and on dissolving in water gives rise to a reduction of temperature. 100 parts of water dissolve, according to Kremers, as follows:—

At	0°	10°	25°	45°	65°	85°	100°
$Pb(NO_3)_2$	38.7	48.3	60.6	80.0	101.0	120.4	9.13.8

It scarcely dissolves in strong alcohol, and is only slightly soluble in aqueous alcohol. Its aqueous solution is precipitated by nitric acid. It has an astringent metallic taste, decrepitates when heated, detonates with brilliant sparks when thrown upon red-hot charcoal, and deflagrates when triturated with sulphur. The salt is largely used in dyeing and calico-printing, for the preparation of mordants, and for the preparation of chrome-yellow.

When the normal salt is boiled with an equal weight of lead oxide and water, crystals of a basic nitrate $Pb(NO_3)OH$ are

thrown down on cooling. These are difficultly soluble in cold, and more readily soluble in hot water. When gently heated it is converted into red lead. If a solution of the normal salt be precipitated with a slight excess of ammonia, and the solution heated in a closed vessel with the addition of some of the normal salt until the smell of ammonia has almost disappeared, a basic nitrate is formed, having the composition $2\text{Pb}(\text{NO}_3)\text{OH} + \text{PbO}$. It is a white powder slightly soluble in water. When an excess of ammonia is employed, the compound $\text{Pb}(\text{NO}_2)\text{OH} + 2\text{PbO}$ is thrown down as a white powder.

Lead Nitrite, $\text{Pb}(\text{NO}_2)_2$. This substance is most readily obtained by decomposing silver nitrite with lead chloride, and concentrating the solution in a vacuum, when yellow prisms separate out, which are easily soluble in water. On evaporating the solution, nitrogen dioxide is evolved, and a basic salt remains behind. If lead nitrate be digested with water in contact with finely divided metallic lead for a few hours at a temperature of 75° , a yellow solution is formed, which on cooling, deposits the basic double salt, $\text{Pb}(\text{NO}_3)\text{OH} + \text{Pb}(\text{NO}_2)\text{OH}$, in glittering yellow plates. Proust, who first obtained this compound, considered it to be a nitrate of a suboxide of lead, whilst Berzelius viewed it as a simple basic nitrite. If its solution be boiled with metallic lead and a large quantity of water, on cooling, orange-yellow prisms separate out, having the composition $\text{Pb}(\text{NO}_2)_2 + \text{Pb}(\text{NO}_3)_2 + 5\text{PbO} + 3\text{H}_2\text{O}$. This salt was formerly termed lead hyponitrate. If lead nitrate be boiled with one and a half times its weight of lead, and fifty times its weight of water for twelve hours in a long-necked flask, pale red needles of basic nitrite of lead, $\text{Pb}(\text{NO}_2)_2 + 3\text{PbO} + \text{H}_2\text{O}$, are formed. Besides these, other basic nitrites of lead are known.

169 *Phosphates of Lead.* When common phosphate of soda is precipitated by acetate of lead, a white precipitate of normal lead orthophosphate, $\text{Pb}_3(\text{PO}_4)_2$, is formed. If a boiling solution of lead nitrate is precipitated by phosphoric acid, a glittering white crystalline precipitate of HPbPO_4 is produced, and the same compound is obtained in the form of crystalline needles when lead pyrophosphate is heated with water to 250° . The pyrophosphate and metaphosphate of lead are white precipitates.

The following minerals are lead phosphates and arsenates isomorphous with apatite :—

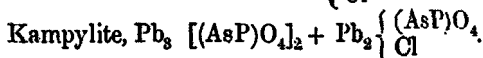
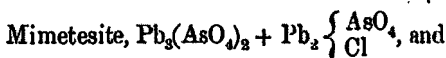
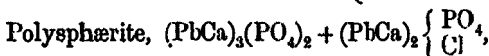
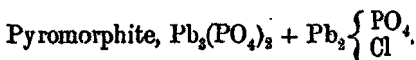

These usually contain a portion of their chlorine replaced by fluorine.

Borates of Lead. If boron trioxide and lead oxide be fused together in the proportion of 2 molecules of the former to 3 of the latter, a yellowish soft glass is obtained, which softens when exposed to the action of hot oil. If double the weight of boron trioxide be employed, the glass obtained is harder and less coloured, and if three times the weight be used a colourless glass is obtained, which possesses the hardness of flint-glass, and which refracts light much more powerfully.¹ When a lead salt is precipitated with borax, a compound having the composition $Pb_2B_6O_{11} + 4H_2O$ is formed, and this when warmed with strong ammonia is converted into a heavy white powder having the composition $PbB_2O_4 + H_2O$, which again, when boiled with a solution of boracic acid, yields an amorphous powder of $PbB_4O_7 + 4H_2O$.

Silicates of Lead. Silica fuses with lead oxide to form a yellow glass. Glass formed of equal parts of lead oxide and silica does not become dull when it is exposed to the action of sulphuretted hydrogen, but if 8 parts of the glass are fused with 1 part of potash, the glass produced becomes tarnished on exposure.² Lead silicate forms a constituent of flint-glass.

170 Carbonates of Lead. *Normal Lead Carbonate*, $PbCO_3$, occurs as cerusite or white carbonate of lead in rhombic crystals isomorphous with arragonite, and also as pseudomorph of galena and lead sulphate. The same compound is formed by precipitating a cold solution of lead acetate by carbonate of ammonia (Berzelius), or by passing carbon dioxide into a dilute solution of sugar of lead (Rose). Cerusite forms colourless transparent lustrous crystals, having a specific gravity of 6.46, whilst the precipitated carbonate has a specific gravity of 6.43. It is scarcely soluble in water; 1 part dissolving in 50,500 parts of

¹ Faraday, "On the Manufacture of Optical Glass." *Phil. Trans.* 1830, p. 1.

² Faraday, *loc. cit.*

water at the ordinary temperature, but in presence of ammonical salts it is somewhat more soluble (Fresenius). A solution of carbon dioxide in water also dissolves it slowly.

Lead forms several basic carbonates, amongst which *white lead* is the most important, since it is manufactured on a very large scale. In the pure state this compound consists of $2\text{PbCO}_3 + \text{Pb}(\text{OH})_2$, or



White Lead has long been known, being called *λευκὸν* by Theophrastus. The process of manufacture as described by him consisted in the action of vinegar on lead, the material formed being scraped off after a time from the surface of the metal. Pliny mentions the same substance under the name of *cerussa* and describes the above method of manufacture. He also states that it may be obtained by dissolving lead in vinegar and evaporating to dryness. Thus it would appear that the difference between white lead and sugar of lead was not known. Geber describes the manufacture as follows: "plumbum ponendo super vaporem aceti fit cerussa," a description which accords with the method employed even up to the present day. For some time white lead was supposed to be a compound of calx of lead with vinegar, and it was not until 1774 that Bergman showed that white lead contains lead calx and fixed air and gave to it the name of "luftsaurer blei-kalk" or "calx plumbi ærata."

The oldest process for the manufacture of white lead is known as the *Dutch process*. In this method conical glazed earthenware pots, 8 inches wide, are filled to one-fourth of their depth with malt vinegar. At one-third of the height of the pot from the bottom are three projecting points on which a cross-piece of wood is laid, and on this are placed vertically a number of leaden plates rolled up into a spiral, and the whole covered with a leaden plate. The pots are then placed under a shed in rows upon horse-dung or spent tannery-bark covered with boards, another layer of dung or decomposing bark laid upon the boards, and on this another row of pots, many rows of pots being thus placed above one another, and the whole covered by the tan or dung. By the slow decomposition of the dung, heat is evolved, which assists the evaporation of the vinegar and causes basic lead acetate to be formed, and this in contact with the carbon dioxide evolved from the putrefaction of the organic matter is converted into white lead. In the course of from 4 to 5 weeks

the greater portion of the lead is converted into white lead, the change taking place from without inwards. The white lead is then detached, ground into a fine paste whilst moist, washed well to free it from adhering acetate, and dried in small round pots. Unwashed white lead contains a considerable quantity (from 2 to 12 per cent.) of the normal acetate.

According to the *German method* of manufacture, plates of lead are hung up in wooden boxes placed in heated chambers containing a stratum of acetic acid, or the plates are suspended in heated chambers having their floors covered with tan and acetic acid.

The *French method*, introduced by Thénard, and the *English method*, suggested by Benson, do not furnish a white lead which possesses the same covering power as that prepared by the other methods. The process in these cases consists in passing carbon dioxide through a solution of a basic acetate of lead, obtained by boiling a solution of sugar of lead with litharge.

Another method, which yields a white lead of excellent covering power, is the process patented by Dale and Milner. This consists in carefully grinding between millstones a mixture of litharge, or any insoluble basic lead salt, with water and bicarbonate of soda. Milner has improved upon this method by grinding a mixture of 4 parts of finely divided litharge with 1 part of common salt and 16 parts of water. After about 4½ hours the reaction is complete. The mixture of basic lead chloride and caustic soda is then brought into a leaden vessel, well stirred with a wooden pestle, and a current of carbon dioxide passed through it until the liquid is neutral. If the carbon dioxide be passed in too long the product is spoiled.¹

171 White lead is a white, earthy, heavy, amorphous powder which appears under the microscope to consist of round transparent globules of the size of from 0·00001 to 0·00004 of an inch in diameter. It was formerly supposed that the feeble covering power of the white lead manufactured according to the French method depended upon the fact that it was crystalline. The specific gravity of that prepared by the Dutch method is somewhat greater than that prepared by the French method, and it therefore absorbs less oil or varnish and gives rise to a thicker colour.

Although it acts as a powerful poison, and is turned black by sulphuretted hydrogen, white lead is still almost exclusively used as a paint, and has been replaced only to a very small

¹ Patent No. 4,053 ; 22nd November, 1875.

extent by zinc-white or baryta-white. This is accounted for by the fact that it possesses a much greater covering power and is much more opaque than is either of the other two.

White lead is often mixed with heavy-spar and gypsum. A mixture of equal parts of white lead and barium sulphate is known as *Venetium white*, whilst *Hamburg white* is a mixture of 1 part of white lead to 2 of barium sulphate, and *Dutch white* of 1 part to 3 of barium sulphate. The amount of this admixture may be readily ascertained by treating a weighed portion of the powder with warm dilute nitric acid, when the barium sulphate remains behind. The estimation may also be made by igniting and heating to the point of fusion and weighing the residue; the amount of sulphate can then be readily calculated, inasmuch as white lead when heated loses the whole of the carbon dioxide leaving lead monoxide behind. An average sample of white lead loses 14 per cent. of its weight on ignition. Hence if a sample loses less than this weight it is easy to calculate how much pure white lead it contains.

Lead carbonate forms a constituent of the following minerals: cromfordite or phosgenite, $\text{PbCO}_3 + \text{PbCl}_2$; lead-hillite, $3\text{PbCO}_3 + \text{PbSO}_4$, and lanarkite, $\text{PbCO}_3 + \text{PbSO}_4$.

Lead Cyanide, $\text{Pb}(\text{CN})_2$, is obtained as a white powder when a solution of a normal lead salt is mixed with potassium cyanide. It is not soluble in the cyanides of the alkali metals, and is decomposed on the addition of an acid. When heated in a closed vessel a mixture of lead and charcoal remains behind which, if it has not been too strongly heated, is pyrophoric.

Lead Cyanate, $\text{Pb}(\text{CNO})_2$, is obtained by mixing solutions of a cyanate and of a soluble lead salt. A dense white precipitate is thrown down, which soon assumes the form of slender needles like chloride of lead. It is soluble in boiling water. This salt may be employed as a ready means of the artificial preparation of urea. (See Vol. I., p. 649.)

POISONOUS ACTION OF LEAD SALTS.

172 The soluble lead salts are strongly poisonous and are employed in medicine. The normal or basic acetate given in doses from 0.3 to 0.6 gram. produces acute symptoms of lead poisoning, which often end fatally.

When taken for a considerable time in small doses, especially in the case of the oxides and carbonates, chronic lead poisoning

is observed. The disease called painters' colic is the chronic form of poisoning by carbonate of lead. The symptoms of chronic lead poisoning are pain in the abdomen, constipation, loss of appetite, thirst, and general emaciation followed by nervous prostration known as lead-palsy, epileptic fits, and total paralysis.

A very characteristic phenomenon accompanying chronic lead poisoning is the appearance of a blue line at the edges of the gums due to the deposition of lead sulphide. This line is often seen in the case of house-painters and the workmen engaged in white-lead works, as well as those occupied in manufactures in which white lead is employed, as, for instance, in the manufacture of glazed cards. On the other hand, plumbers, who only handle metallic lead, which is not poisonous, are not subject to the disease.

THE ACTION OF LEAD UPON WATER.

As lead acts as a cumulative poison, its salts produce serious results if taken into the system even in very minute quantities for a length of time. Drinking-water is usually collected in lead-lined cisterns and passes through leaden pipes, and as water under certain circumstances can take up notable quantities of lead it becomes of great importance to determine the conditions under which the solvent action is exerted. A fresh bright surface of lead does not tarnish in a perfectly dry atmosphere or when sealed up in a vessel filled with pure distilled water from which all air has been expelled by boiling. If, however, it be exposed to the united action of air and water the lead is oxidized to hydroxide which dissolves. After a time, this is converted by the action of the atmospheric carbon dioxide into an insoluble basic carbonate. Lead hydroxide is then again formed, and thus the corrosive action may be continued.

Potable waters always contain a certain amount of salts in solution and the corrosive action on lead depends upon the nature and quantity of the salts thus present. The ammoniacal salts act most prejudicially on water in this respect; this is especially the case with ammonium nitrate, which greatly assists the oxidation and solution of the lead. Other nitrates do not, however, appear to possess this power, and sulphates, phosphates, and carbonates either retard or altogether prevent this action, and hence water containing carbonic acid in solution or

temporarily hard water consisting of a solution of calcium carbonate in carbonic acid gives rise to the formation of insoluble basic lead carbonate, which however may be dissolved in the presence of large quantities of carbon dioxide.

The following table contains the results of experiments on the solubility of lead in water containing various salts in solution. Bright plates of lead having a surface of 5,600 sq. mm. were placed in flasks which contained 500 cco. of water in which the salts are dissolved, the saline solutions being allowed to act upon the lead for different periods of time: ¹—

Salt.	Grams per Liter.	Milligrams per Liter of Lead dissolved in		
		24 hours.	48 hours.	72 hours.
NH ₄ NO ₃ . . .	0·02	13·0	—	25·0
" . . .	0·04	15·0	—	32·0
KNO ₃ . . .	0·02	20	2·0	—
NaNO ₃ . . .	0·05			
KNO ₃ . . .	0·07	—	—	0·5
K ₂ SO ₄ . . .	0·50			
KNO ₃ . . .	0·045	—	—	0·3
K ₂ CO ₃ . . .	0·308			
CaCl ₂ . . .	0·25	0·5	0·5	0·5
NH ₄ NO ₃ . . .	0·02	—	—	1·8
CaCl ₂ . . .	0·06			
Na ₂ SO ₄ . . .	0·020	—	—	0·1
K ₂ CO ₃ . . .	0·040			
CaCl ₂ . . .	1·100	—	—	0·2
K ₂ CO ₃ . . .	0·31			
Distilled water with carbon dioxide at ordinary pressure . . .	}	3·0	—	3·0
Ditto with carbon dioxide at a pressure of about 6 atmospheres . . .		14·8	24·0	—
Distilled water . . .		2·0	2·0	3·0

LEAD AND SULPHUR.

173 *Lead Sulphide*, PbS, occurs in nature as galena, crystallized in cubes or in other combinations of the cubic system. It possesses a bluish-grey colour, and has a specific gravity varying

¹ M. M P. Muir, *Proc. Man. Phil. Soc.* 1875, p. 31. See also *Chem. Soc. Journ.* 1877.

from 7.25 to 7.7. This mineral was known to the ancients under its present name, but the fact that it contained sulphur was not recognised until after some time. Thus even Kunkel was unacquainted with this fact, though Boyle¹ was aware that when galena is heated with scrap-iron, metallic lead is formed and recommended this mode of producing lead.

When sulphur vapour is led over metallic lead it takes fire and burns, forming a crystalline sulphide, and even tolerably thick strips of lead take fire in sulphur vapour with vivid glow, depositing half-fused globules of lead sulphide. It can also be prepared by fusing lead oxide with an excess of sulphur. When sulphuretted hydrogen is passed into a solution of lead nitrate, an amorphous black precipitate is formed, but if the gas be passed into a dilute solution of the salt containing free nitric acid, a crystalline precipitate is obtained, consisting of microscopic cubes (Muck).

Sulphide of lead fuses at a strong red-heat, and when heated in a current of hydrogen or carbon dioxide it sublimes in cubes which often have a diameter of 1.5 mm. Crystals of galena are often obtained in lead-works in a similar way. On the other hand, octohedral crystals may be obtained by fusing 1 part of the precipitated sulphide with 6 parts of potash and 6 parts of sulphur (Schneider). Nitric acid converts galena, with separation of sulphur, partly into the nitrate and partly into the sulphate, the latter compound being formed in the largest quantity when the acid is strongest. Hot concentrated hydrochloric acid dissolves it with evolution of sulphuretted hydrogen.

A finely-divided mixture of 100 parts of galena and 84 of metallic lead, heated for a quarter of an hour in a well-closed charcoal crucible in a wind furnace, yields 144 parts of a dull, lead-coloured, fine-grained, semi-malleable, soft mixture, showing a dark grey colour on the cut surface. This substance corresponds to the formula Pb_4S . If this process is carried on in an earthenware crucible and covered with borax, a dark leaden-grey coloured crystalline mass is obtained corresponding to the formula Pb_2S .

Lead Chloro-sulphide, $PbCl_2 + 3PbS$. When an aqueous solution of a lead salt, such as the chloride, is precipitated by a small quantity of sulphuretted hydrogen, in presence of hydrochloric acid, a yellowish-red precipitate of the above compound is produced. An excess of sulphuretted hydrogen converts it into

¹ *A Hydrostatical Way of Estimating Ores of Lead.*

the sulphide. This substance may also be obtained by warming freshly precipitated sulphide of lead with a solution of lead chloride. The compound is decomposed by hot water into lead chloride, which dissolves, and black lead sulphide, which remains behind.

DETECTION AND ESTIMATION OF LEAD.

174 The soluble lead salts possess a sweet astringent taste, whence the name sugar of lead has been given to the acetate, and are very poisonous. These two properties of the lead compounds have been long known, and it became in early times of importance to detect the presence of lead, inasmuch as the compounds of this metal were largely employed for a great variety of purposes. Thus, for instance, the Romans were in the habit of boiling their poor wines in leaden vessels, and Pliny mentions the fact that the point at which the wine becomes sour can be detected by hanging a strip of lead in it and then observing when this undergoes any change in its appearance. In later times the addition of metallic lead to a cask of sour wine was said to render it drinkable. At a still later date, litharge appears to have been employed for the same purpose. It was observed that the treatment of wine with lead could be detected by the addition of sulphuric acid, and in 1707 Zeller suggested that an extract of orpiment and lime-water (containing, therefore, sulphide of calcium) was an invaluable test for the presence of lead, inasmuch as this liquid turns all lead salts black. This reaction led to the simultaneous suggestion, in 1787, by Fourcroy and Hahnemann of the application of water acidified with hydrochloric acid and then saturated with sulphuretted hydrogen for the detection of lead, and thus the most important reagent which we now employ in analytical chemistry for the detection and separation of the metals was introduced.

Potable water may be examined in this way for lead by passing sulphuretted hydrogen through water slightly acidified by hydrochloric acid. It is, however, to be remembered that many other metals, such as mercury, copper, and bismuth, also produce black precipitates. The absence of these metals must, therefore, be ascertained before the presence of lead can be certainly proved. Black lead sulphide can be readily distinguished from other black sulphides insoluble in dilute hydrochloric acid by dissolving it in warm dilute nitric acid and

filtering the solution ; on addition of sulphuric acid to the filtrate, a white precipitate of lead sulphate is obtained. By means of this reaction lead may be detected in the presence of all the other metals and separated from them. Lead compounds, heated before the blowpipe on charcoal, yield a malleable bead of lead readily soluble in warm nitric acid, and the solution yields a precipitate with sulphuric acid.

Another characteristic test for lead is, that when present in not too dilute solution, a crystalline precipitate of the chloride is obtained on the addition of hydrochloric acid. This is soluble in boiling water, and separates out on cooling in crystalline needles. Potassium chromate gives, in the presence of free nitric acid, a fine yellow precipitate of chrome yellow, $PbCrO_4$. In order to detect small quantities of lead in presence of large masses of organic matter, as is necessary in cases of lead poisoning, the mass is evaporated to dryness with sodium carbonate, the residue ignited gently, and the carbonized mass rubbed fine and carefully lixiviated, when small glittering heavy spiculae of metallic lead remain behind. These can be examined as already described.

Lead is easily determined quantitatively in the form of sulphate, being precipitated with dilute sulphuric acid and this washed with strong alcohol. For certain separations lead is also determined as the chloride. In this case the solution is precipitated by hydrochloric acid, evaporated in a water-bath, and the concentrated liquid treated with a mixture of ether and alcohol, in which the chloride is insoluble. Lead carbonate and lead oxalate are also occasionally used for the estimation of lead, and these precipitates are then converted by ignition into lead oxide.

Lead compounds impart a pale tint to the non-luminous gas-flame and this exhibits characteristic lines in the green (Werther.) The spark spectrum of lead contains a large number of lines between the orange and violet. The brightest and most characteristic of these is a violet line, a somewhat less bright one in the green, and a fainter one lying near the less refrangible of the "D" lines of Fraunhofer (Lecoq de Boisbandran.)

The most accurate determinations of the *atomic weight of lead* are those of Stas. By the conversion of pure lead into the nitrate he obtained the number 206.4 as a mean of ten experiments. Six other experiments in which the nitrate was converted into the sulphate gave the number 206.41.¹

¹ *Bull. Roy. Acad. Belg.* [2], x. 298.

THALLIUM, Tl = 203·6.

175 Thallium was discovered in the year 1861 by Crookes¹ in a seleniferous deposit obtained from a sulphuric acid manufactory at Tilkerode in the Harz. Selenium was being prepared from this deposit, and a considerable residue was left when the material was distilled. This was supposed at first to contain tellurium, but examination with the spectroscope showed that a new element was present whose spectrum consisted of one bright green line, whence the name of the element, from *θάλλος*, a green twig. It was first supposed that this element was a non-metal belonging to the sulphur group. In 1862 Lamy,² who discovered the element independently of Crookes, declared it to be a metal, and prepared some of it in the metallic condition.

Thallium occurs in small quantities in many varieties of iron and copper pyrites, and in a few micas containing lithium. A mineral containing thallium has been discovered by Norden-skjöld³ in a copper mine at Skrikerum, in Sweden. This mineral, to which he gave the name of crookesite, contains:—

Thallium . . .	17·25	per cent.
Selenium . . .	33·28	„
Copper . . .	45·76	„
Silver . . .	3·71	„
	—	
	100·00	„

The mineral water of Nauheim, near Frankfort, as well as that of many other mineral springs, contains small quantities of thallium.

For the purpose of preparing thallium it is best to employ the fine dust from sulphuric acid works, in which pyrites containing thallium is burnt. The dust is repeatedly boiled out with water acidulated with sulphuric acid, the solution concentrated and the thallium precipitated with zinc, when it is deposited in the form of needles or glittering plates. Thallium may be obtained in a purer condition by boiling up the flue dust with water and adding hydrochloric acid to the concentrated

¹ "On the Existence of a new Element, probably of the Sulphur Group," *Chemical News*, iii. 193 (March 30, 1861).

² *Société Impériale des Sciences de Lille*, May 2 and 16, 1862.

³ *Ann. Chem. Pharm.* cxlv. 127.

clear solution. The precipitate is washed and gradually dissolved in half its weight of hot sulphuric acid, and then heated until all the hydrochloric and the greater part of the sulphuric acid has been driven off. The residue is then dissolved in water, the solution treated with sulphuretted hydrogen for the purpose of precipitating arsenic, antimony, bismuth, mercury and silver, and ammonia added to the filtrate to throw down any iron or alumina which may be present. The filtrate, when concentrated, yields crystals of pure thallium sulphate, from which the metal may be obtained by deposition with zinc or by electrolysis. According to Bunsen¹ the solution of zinc sulphate obtained at the Juliushütte, at Goslar, contains 0.05 per cent. of thallium chloride, and if metallic zinc be allowed to remain in contact with the solution, copper, thallium, and cadmium are thrown down in the metallic state. The precipitated metals are then carefully washed with water and digested with dilute sulphuric acid to dissolve the two latter metals. If potassium iodide be then added to this solution, thallium iodide separates out, and this on treatment with potassium cyanide yields pure metallic thallium.

Pure thallium has a bluish-white tint and a lead-like metallic lustre. It is crystalline, and so soft that it may be marked with the nail and leaves a streak on paper. It is malleable, but possesses little tenacity, and can with difficulty only be filed or sawn, as the particles stop up the interstices of the tool. Its specific gravity is 11.8; it melts at 290° (Lamy), volatilizes at a very high temperature, and may be distilled in a current of hydrogen. When heated before the blow-pipe it oxidizes, a pale reddish vapour being evolved which possesses a peculiar smell. It decomposes water at a red-heat and dissolves readily in dilute acids.

THALLIUM AND OXYGEN.

Thallium forms a monoxide and a trioxide, and yields two corresponding series of salts, known as the thallic and the thallic compounds.

Thallium Monoxide, Tl₂O. When the metal is exposed to the air its surface assumes a dull grey colour, due to the formation of the above compound. This may be obtained in the pure state

¹ *Phil. Mag.* [4] xxix. 168.

by heating the hydroxide in absence of air to a temperature of 100°. It is a black powder melting at about 300°, and easily soluble in water with the formation of the hydroxide.

Thallium Hydroxide, $TlOH$, is formed by the action of water upon the metal in presence of air. In order to prepare it in larger quantity a solution of the sulphate is precipitated with the necessary quantity of baryta water. It crystallizes in long yellow needles having the formula $TlOH + H_2O$. It is readily soluble in water, and the solution is colourless and possesses a strong alkaline reaction, turning yellow turmeric-paper brown. This brown colour disappears, however, after some time as the hydroxide destroys the colouring matter. Hence if turmeric-paper be written upon with metallic thallium the writing at first appears brown but gradually disappears¹ (Erdmann).

Thallium Trioxide, Tl_2O_3 . When molten thallium is plunged into oxygen-gas it takes fire with formation of this oxide. At a red-heat this is, however, converted into the monoxide. It is also obtained by passing a galvanic current from a few Bunsen's elements through acidulated water, the positive pole consisting of metallic thallium which then becomes covered with a black deposit of this oxide² (Wöhler):—

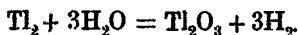

It forms a dark reddish powder which is insoluble in water and the alkalis.

If a hot solution of thallium chloride in sodium carbonate be mixed with one of sodium hypochlorite, a brown precipitate is obtained, which probably consists of thallium tri-hydroxide $Tl(OH)_3$, but on drying it possesses the composition $TlO(OH)$. This same compound is also formed when thallium trichloride is decomposed by an alkali. When heated with hydrochloric acid it evolves chlorine, whereas oxygen is given off when it is heated with strong sulphuric acid. On heating it is transformed into the trioxide and afterwards into the monoxide. When thallium hydrate is suspended in strong caustic potash, and a current of chlorine passed in, a deep reddish-violet solution is formed, which probably consists of the potassium salt of a thallic acid.

¹ *Journ. prakt. Chem.* lxxxix. 381.

² *Ann. Chem. Pharm.* cxlvi. 243, 375.

Thallium forms two series of compounds corresponding to the two oxides, and distinguished as the *thallious compounds* and the *thallic compounds*.

THALLIOUS COMPOUNDS.

Thallium Monochloride or Thallious Chloride, $TlCl$, is formed when the metal burns in chlorine, and it separates out when hydrochloric acid is added to a tolerably concentrated solution of a soluble thallium salt, forming a white curdy precipitate which assumes a violet tint on exposure to light (Hebberling). It crystallizes from hot saturated solution in the form of cubes, and melts easily, yielding a yellowish liquid which on cooling solidifies to a white, shining, crystalline, somewhat flexible mass, having a specific gravity of 7.02 (Lamy). According to Hebberling 100 parts of water dissolve the following quantities of the salt:—

At	0°	16°	100°
$TlCl$	0.198	0.265	1.427.

It is less soluble in dilute hydrochloric acid, and hence the salt is precipitated from aqueous solution on addition of this acid. It is scarcely soluble in ammonia, and is insoluble in alcohol.

Thallious Bromide, $TlBr$, is a very pale yellow precipitate less soluble than the chloride, with which it possesses strong analogies. Bromine does not attack the metal so readily as chlorine, but in presence of water the metal is readily dissolved by bromine.

Thallious Iodide, TlI , is formed when thallium and iodine are heated together. It may also be obtained by precipitating a solution of a thallium salt with potassium iodide when it is thrown down as a beautiful yellow crystalline powder, which melts at 190°, yielding on solidification a red mass, which on standing becomes yellow. If it is precipitated from a hot solution containing potassium acetate it is deposited in the form of microscopic orange-yellow cubes or cube-octohedrons (Werther). It is very difficultly soluble in cold water, 1 part requiring 16,000 parts for its solution, whereas it dissolves in 800 parts of boiling water. When heated to 190° thallious iodide becomes scarlet, melts at a higher temperature, solidifying to form a red crystalline mass which becomes yellow on standing for some

days. It is less soluble in a solution of potassium iodide, in alcohol, and in dilute acetic acid, than in water itself. It is not decomposed by dilute sulphuric acid, or hydrochloric acid, or by caustic potash. Nitric acid, however, decomposes it with evolution of iodine.

Thallious Fluoride, TlF , is formed by dissolving the carbonate in hydrofluoric acid. It crystallizes in glittering octohedrons and cube-octohedrons. It dissolves in 1.25 parts of water at 15° , and more readily in boiling water. It melts on heating, and may readily be sublimed in a current of hydrofluoric acid.

Thallium Hydrogen Fluoride, $TlHF_2$, is formed by allowing a solution of the fluoride in aqueous hydrofluoric acid to evaporate in a vacuum over sulphuric acid. It crystallizes in similar forms as thallious fluoride, and dissolves in its own weight of water.

Thallious Chlorate, $TlClO_3$. This salt is formed when the metal is dissolved in chloric acid, or when saturated solutions of thallium nitrate and potassium chlorate are mixed together. It crystallizes in long anhydrous needles.

Thallious Perchlorate, $TlClO_4$, is formed by dissolving thallium in aqueous perchloric acid, or by precipitating barium perchlorate with thallium sulphate. It crystallizes in transparent rhombic tables, isomorphous with potassium perchlorate, and having a specific gravity of 4.844 at $15^{\circ}5$. 1 part of this salt dissolves at 15° in 10 parts, and at 100° in 0.06 parts of water; it is only slightly soluble in alcohol (Roscoe).

Normal Thallious Sulphate, Tl_2SO_4 . This salt crystallizes in rhombic prisms isomorphous with potassium sulphate, and has a specific gravity of 6.6. 100 parts of water dissolve, according to Lamy, as follows:—

At	18°	62°	101°
Tl_2SO_4	4.8	11.5	19.3

Thallium sulphate melts at a red heat, decomposing on exposure to air with evolution of sulphur dioxide.

Hydrogen Thallious Sulphate, $H TlSO_4 + 3H_2O$, crystallizes in short thick prisms, which melt on heating, and then suddenly decompose with evolution of vapours of sulphuric acid into the normal sulphate.

Thallious Nitrate, $TlNO_3$. Nitric acid attacks thallium more easily than any other acid does. Thallium nitrate crystallizes in opaque, white rhombic prisms, having a specific gravity of

5.55. The crystals melt at 205° , and on cooling the fused mass solidifies to a glass-like solid. 100 parts of water dissolve, according to Lamy:—

At	18°	58°	107°
Tl NO_3	10.67	43.48	588.2

It is insoluble in alcohol.

176 *Phosphates of Thallium.* These salts are isomorphous with the analogous potassium compounds.

Normal Thallious Orthophosphate, Tl_3PO_4 , is obtained in the form of needle-shaped crystals by precipitating the corresponding potassium salt with a thallium salt. It is also formed by the precipitation of ordinary sodium phosphate, but this precipitation is not complete (Lamy). 1 part dissolves at 15° in 201, and at 100° in 149 parts of water (Crookes). It is easily soluble in ammoniacal salts.

Monohydrogen Thallious Orthophosphate, $\text{HTl}_2\text{PO}_4 + \text{H}_2\text{O}$, is formed by neutralizing a boiling solution of phosphoric acid with thallium carbonate. When evaporated to a syrup, the concentrated solution deposits rhombic crystals. These lose their water at 200° , and when they are heated to dull redness, a glassy mass of pyrophosphate remains behind.

Dihydrogen Thallious Orthophosphate, $\text{H}_2\text{Tl PO}_4$. This salt is obtained when phosphoric acid is added to a solution of the foregoing salt until the liquid exhibits a distinctly acid reaction. It crystallizes in monoclinic pearly tablets, dissolves readily in water, and on ignition it is converted into the glassy metaphosphate.

Silicate of Thallium. A solution of the hydroxide when boiled with amorphous silica dissolves this substance, and when the solution is evaporated a crystalline mass, having the composition $\text{Tl}_6\text{Si}_{10}\text{O}_{27} = 3\text{Tl O} + 10\text{Si O}_2$, and also containing water, separates out. When thallium oxide is fused with silica a yellow strongly refracting glass is obtained, which is occasionally employed in place of lead silicate for optical glass.

Normal Thallious Carbonate, Tl_2CO_3 . Thallium hydroxide readily absorbs carbon dioxide. Thus if the moistened metal be allowed to lie exposed to the air, it becomes covered with needle-shaped crystals of the carbonate. This salt crystallizes from solution in water in glittering monoclinic prisms, which have a caustic metallic taste and an alkaline reaction. 100 parts of water dissolve, according to Lamy:—

At	18°	62°	100°·8
Tl_2CO_3	5·23	12·85	22·40

It is insoluble in alcohol. It fuses on heating and decomposes at a higher temperature with evolution of carbon dioxide.

Hydrogen thallious carbonate appears not to be known in the solid state.

Thallium Cyanide, $TlCN$. This salt is obtained by mixing strong solutions of potassium cyanide and thallium nitrate (Crookes). It separates in shining glittering plates not very soluble in water. When heated it decrepitates and melts easily, volatilizing when strongly heated on platinum foil without reduction and without acting on the platinum.

Thallium Monosulphide, or Thallious Sulphide, Tl_2S , is a black precipitate formed when sulphuretted hydrogen is passed into an alkaline- or acetic-acid-solution of a thallious salt. If the solution contains a trace of free sulphuric acid, the sulphide separates out in the cold in microscopic tetrahedrons (Hebberling). If the sulphide or a mixture of the metal with sulphur be melted in absence of air, a black glittering mass is obtained on cooling having a specific gravity of about 8, and a general appearance somewhat like graphite. It is insoluble in water, alkalis, and potassium cyanide. It dissolves with difficulty in acetic acid, but readily, however, in mineral acids. The precipitated sulphide oxidizes on exposure with formation of sulphate, and when heated in a current of hydrogen thallium remains behind.

THALLIC COMPOUNDS.

177 *Thallium Trichloride, or Thallic Chloride*, $TlCl_3$, is formed when the monochloride is treated with chlorine under water. If the solution be evaporated in a vacuum, colourless deliquescent prisms having the composition $TlCl_3 + H_2O$ are deposited. When metallic thallium is strongly heated in chlorine gas, a yellowish-brown mass is obtained on cooling, which has the composition $3TlCl + TlCl_3$. This substance is difficultly soluble in cold, but readily soluble in hot water, separating from this solution in dark-yellow six-sided tablets closely resembling lead iodide in their appearance. Ammonia decomposes it into the monochloride and the trioxide.

When the metal or the monochloride is carefully heated in

a stream of chlorine the compound $TlCl + TlCl_3$ is obtained, and this on further heating is transformed into the foregoing compound. If an alcoholic solution of the trichloride be heated with alcoholic ammonia, a white crystalline precipitate of $(NH_3)_3TlCl_3$ separates out; this is decomposed in contact with water with formation of the violet-coloured trioxide:—



Thallic Sulphate, $Tl_2(SO_4)_3 \cdot 7H_2O$, crystallizes on evaporation of a solution of the trioxide in warm dilute sulphuric acid in the form of thin colourless tablets, which are decomposed by water with separation of the hydrated trioxide.

Thallic Nitrate, $Tl(NO_3)_3 \cdot 8H_2O$, is deposited from a solution of the oxide in nitric acid in colourless crystals, which decompose on heating with water.

Thallium Trisulphide, or Thallic Sulphide, Tl_2S_3 , is formed when the metal is fused with an excess of sulphur. It is a black amorphous mass, which at a summer temperature is soft and plastic like pitch. Below 12° it is hard and brittle, exhibiting a glassy fracture.

If 1 part of thallium sulphate be fused with 6 parts of sulphur and 6 parts of potassium carbonate, and the mass treated with water, a red crystalline powder remains behind having the composition $KTlS_2$. This substance is not attacked by caustic potash, but decomposes in presence of acids.

DETECTION AND ESTIMATION OF THALLIUM.

178 The salts of thallium are poisonous. The soluble salts possess a disagreeable metallic taste. Their presence may be readily detected by the beautiful green colour which they impart to a non-luminous gas-flame. The spectrum of this flame consists of one bright green line having a wave-length of 5439, not coincident with any line in the solar spectrum. It may be readily separated from all the other metals by treating an acid solution with sulphuretted hydrogen, filtering off the separated sulphides, and precipitating the filtrate with sulphide of ammonium, which throws down thallium sulphide as a black precipitate. This precipitate may contain other sulphides; to separate these, it is washed, dissolved in nitric acid, and the boiling solution neutralized with sodium carbonate; on cooling, platinum chloride is added, when a pale yellow precipitate of

the double chloride of thallium and platinum, $2 \text{ Tl Cl} + \text{PtCl}_4$, is thrown down. This compound dissolves in 15,600 parts of cold water, and hence may be employed for the quantitative determination of thallium. Thallium may also be precipitated by potassium iodide as thallium iodide, which in presence of an alkaline iodide is altogether insoluble in water.

The Atomic Weight of Thallium has been determined by Crookes¹ by converting the metal into the nitrate, and the sulphate into barium sulphate. Ten experiments gave numbers lying between 203.628 and 203.666.

The position of thallium amongst the metals is a peculiar one. On the one hand it possesses strong analogies with the metals of the alkalis, such as potassium, yielding a soluble strongly alkaline hydroxide, and a soluble carbonate and silicate, and its sulphate unites with the sulphates of the magnesium group to form double salts having the general formula $\text{Tl}_2\text{SO}_4 + \text{M}''\text{SO}_4 + 6\text{H}_2\text{O}$, isomorphous with the corresponding potassium and ammonium compounds. Besides, thallium can replace, either partly or wholly, the alkali metals contained in alum, and, like these again, it forms an insoluble platinum double chloride, isomorphous, as are also the nitrate and phosphates, with the corresponding potassium compounds. On the other hand, in its physical properties as well as in those of its haloid salts, with the exception of the fluoride, it closely corresponds to lead, and it also forms a black insoluble sulphide. In consequence of this peculiar behaviour, Dumas, on the occasion of the discussion of Lamy's investigation in the French Academy, termed thallium the ornithoryncus amongst the metals.

¹ *Phil. Trans.* 1873, p. 277.

METALS OF THE COPPER GROUP.

Copper. Silver. Mercury.

179 THESE metals do not decompose water at a red-heat; each forms several oxides, and they are easily oxidized by nitric acid and hot concentrated sulphuric acid. They are precipitated in the metallic state from their solutions in presence of the metals of the foregoing group.

COPPER. $\text{Cu} = 63.1$.

Copper of all the metals is the one which was first employed by man. This is explained by the fact that copper occurs in the native condition, and thus requires no metallurgical treatment. In the Hebrew Scriptures copper is termed *Nehosheth*, a word derived from the root *nahash*, to glisten. This is translated by *Χαλκός* in the Septuagint, and this again by *aes* in the Vulgate. By both of the latter words the ancients understood not only copper, but brass and bronze. Copper was afterwards specially designated as *aes cyprium*, or simply *cyprium*, a name which afterwards became *cuprum*.

Geber appears to have noticed that copper is easily attacked by acid liquids, and hence it was termed *meretric metallorum* by the alchemists. Inasmuch as it was derived from Cyprus, copper was considered to be the metal specially sacred to Venus, and in the writings of the alchemists it is generally known by the name of this goddess and symbolized by ♀. Basil Valentine was the first to note the power possessed by iron to precipitate metallic copper from solutions of its salts. In his *Last Testament* we read: "The cement or *ley* from Schmölnitz in Hungary eats iron into slime, and when the iron mud is taken out of the trough it is found to be good ♀ (copper)." In his *Currus Triumphalis Antimonii* he says, "From iron a ♀ (copper) can be

got by natural means, as, for instance, by an acrid ley from Hungary which gives to it (the iron) such a metallic colour that it is converted into the best copper."

It would thus appear that this change was regarded as a transmutation of iron into copper, and Paracelsus and many other chemists seem to have held similar views with respect to this reaction. Wedel in 1664 made special inquiry into the nature of the wonderful transmutation of iron into copper by means of this Hungarian liquor; and so late as 1690 Stisser, who was professor of chemistry in Helmstedt, believed that the formation of copper precipitate was a proof of the possibility of the transmutation of metals.

It was long before these erroneous views concerning this precipitation of copper were corrected, although Van Helmont rightly surmised that the copper exists in the solution from which it is precipitated by the iron. Boyle first proved this to be the case, and in his *History of Fluidity and Firmness*,¹ published in the year 1661, he describes the precipitation of copper from its solutions by metallic zinc, and in 1675 in his *Treatise on the Mechanical Causes of Chemical Precipitation*,² explains the action of iron upon copper solutions by the supposition that the solvent permits the metal to be precipitated in order to take up the precipitant.

Copper occurs in the native state in various parts of the world, especially, sometimes in enormous masses, in the copper region of Lake Superior, where it occurs in veins traversing red sandstone and trap. It is also found in the same condition in Cornwall, the Faroe Islands, Siberia, and the Ural, and many other localities in North and South America. Native copper almost invariably contains small quantities of silver and a few other metals, such as bismuth, lead, &c. Cupric oxide, CuO , black oxide of copper, also occurs in nature, as tenorite or melanconite. Cuprous oxide, Cu_2O , cuprite or red copper ore, occurs in larger quantities. Many other copper salts occur native. Of these the most important are malachite, $\text{CuCO}_3 + \text{Cu(OH)}_2$; azurite or blue carbonate of copper, $2\text{CuCO}_3 + \text{Cu(OH)}_2$. Copper also occurs widely distributed in combination with sulphur as vitreous copper, chalcocite, or copper glance, Cu_2S ; covellite or indigo copper, CuS ; copper pyrites, or chalcopyrite, CuFeS_2 , and erubescite or purple copper ore, Cu_3FeS_3 .

180 Copper-smelting.—The methods in use for the extraction of copper differ considerably, according to the nature of the ore

¹ *Op. i.* p. 377.

² *Op. iv.* p. 329.

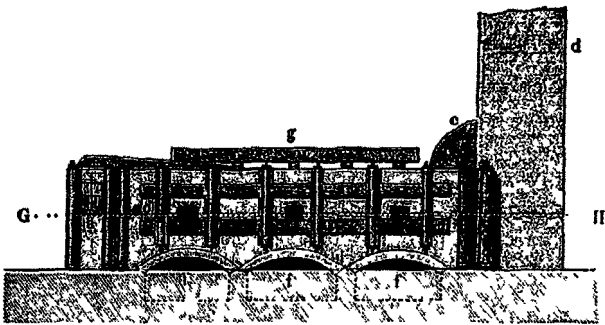

FIG. 86

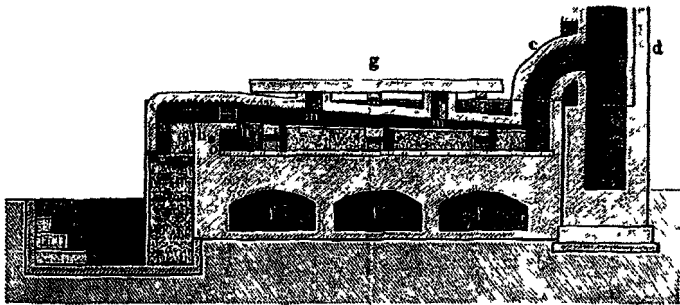

FIG. 87.

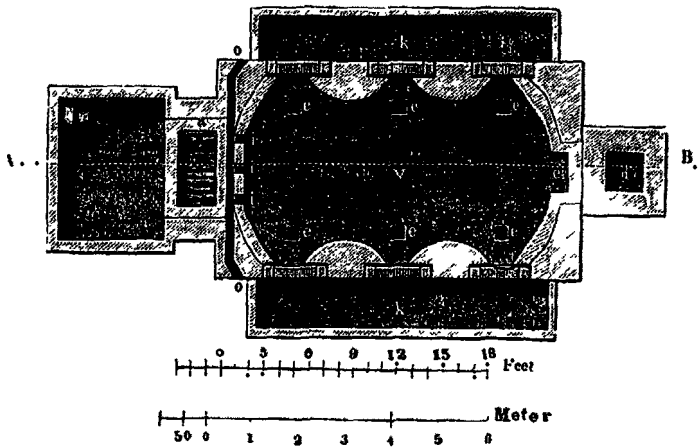

FIG. 88

from which the metal is to be derived. We shall here only describe two of these dry processes, one the English method of copper-smelting as carried on at Swansea and in Lancashire, and the other known as the Mansfeld process in use on the Continent, and especially applicable to working the cuprous schists of Mansfeld in Prussia, which are as a rule poor in copper.

The English process is adapted for all kinds of copper ores, and it is by this plan that by far the greater portion of the metal brought into the market is smelted. The first operation is the calcination of the mixed ores; these consist of copper pyrites and copper carbonates, with iron pyrites containing silicates and gangue usually of quartz.

The following is the average composition of the ores in use in one of the Swansea copper-works (Phillips):—

Copper	13
Iron	29
Sulphur	24
Silica	34
	100

Figs. 86, 87, and 88 show the construction of the ordinary *calcining furnace*. In some copper-works the furnaces are heated with gas, Figs. 91 and 92, and Siemens's regenerative apparatus has been successfully applied. The mixture of ore is brought on to the bed of the furnace from the cast-iron trough, the bottom of which is provided with two sliding-doors. From three to three-and-a-half tons of ore is introduced by withdrawing these doors, and then spread evenly over the floor of the furnace by long iron rakes introduced through the working-doors, of which there are three on each side. The ore is stirred occasionally with iron paddles to expose a fresh surface to the oxidising action of the hot air until after the lapse of from twelve to twenty-four hours sufficient quantities of the oxides of copper and iron have been formed. The roasted ore is then raked through the openings (*ee*, Fig. 88), which had hitherto been covered by slabs of fire brick, into the arched chambers (*ff*, Fig. 87), where it is allowed to cool before being transferred to the *melting-furnace*, the construction of which is shown in Figs. 89 and 90, the bed being, however, generally shallower than is represented.

Here the second operation is performed. This consists in fusing the roasted ore with an admixture of *metal slag* derived from a

subsequent process, and consisting chiefly of iron silicate, the object being to obtain a fused mass or *regulus* consisting of a mixture of the sulphides of copper and iron, termed *coarse metal*,

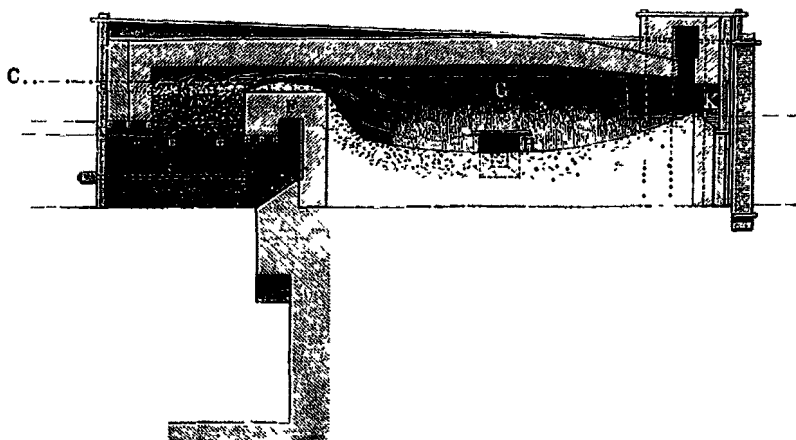

FIG. 89.

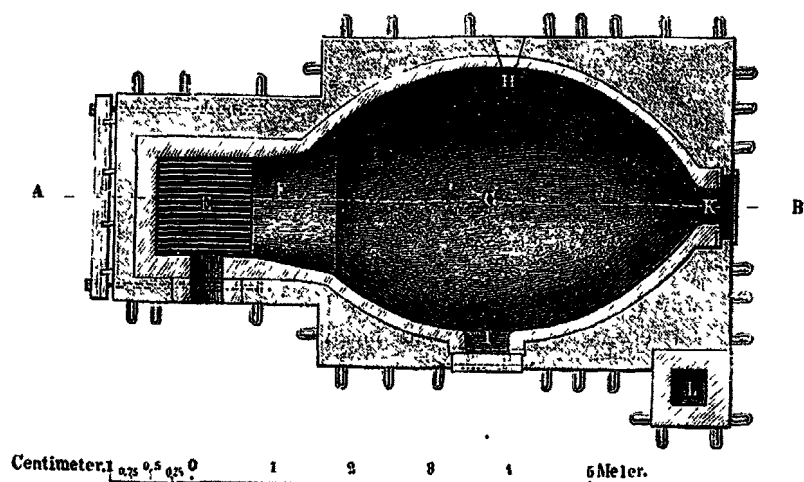

FIG. 90.

whilst a slag is at the same time formed which consists of a silicate of iron and contains little or no copper, and is called *ore-furnace slag*. The temperature needed in this melting process is much

higher than that required in the previous operation, and the chemical changes which go on are simple enough. The copper oxide of the roasted ore undergoes decomposition with a portion of the sulphide of iron with formation of copper sulphide and oxide of iron; this latter oxide then combining with the silica present to form a fusible slag of iron silicate. In order to obtain by this means an ore-furnace slag free from copper, it is found that the mixture of ore brought into the furnace must not contain more than 14 per cent. of copper. Whilst, on the other hand, the percentage of copper ought not to sink below 9, otherwise the consumption of fuel becomes extravagant. The coarse metal, or crude copper sulphide, which usually contains about 35 per cent. of copper and about 23 per cent. of sulphur, is nearly of the same composition as copper pyrites, CuFeS_2 . The fused coarse metal is usually run off, after skimming, through the tap-hole into water, and thus obtained in a granulated condition.

The third operation is to calcine the granulated or crushed regulus, or coarse metal, for the purpose of oxidising that portion of the sulphur which is combined with iron, so that when again melted, in the fourth operation, with the addition of *roaster-slag*, *refinery slag*, and oxidised raw ores, a nearly pure copper sulphide, Cu_2S , called *white-metal* or *fine-metal* containing about 75 per cent. of copper, is obtained. The melting-furnace used in this last operation is identical in construction with that employed in the first fusion, and the slags which are formed chiefly consist of iron silicate, but contain some quantity of copper, and are termed metal-slugs, being employed, as has been stated, in the first melting process.

The white-metal is then subjected to a roasting process carried on in a reverberatory furnace in which air-holes are left. In this way a portion of the oxide formed decomposes a part of the sulphide, with production of metallic copper and sulphur dioxide:—

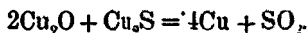

The metal thus reduced is filled with cavities, and hence it is termed *blister-copper*. It still contains from 2 to 3 per cent. of impurities, chiefly consisting of iron and other metals, and these are removed in the sixth or last, or *refining process*.

For this purpose the blister-copper is again fused in a melting-furnace constructed like the others, except that its floor is inclined towards a point near the door and near the chimney.

Upon this floor a charge of about eight tons of blister-copper is brought, and the slags having been removed by skimming from the surface of the molten metal, this is well stirred up, or *rabbed*. The metal in this condition is termed *dry copper*. In this state it is however unfit for use, as it contains a small proportion of oxygen, in combination as cuprous oxide, which renders it brittle. To eliminate this, the metal has to be *toughened*. This is effected by covering the surface of the molten metal by a thin layer of anthracite, which reduces the oxide contained in the surface layer of metal, whilst that contained in the lower portions is removed by plunging a young pole of green birch-wood into the molten metal. Large volumes of reducing gases, consisting of hydrocarbons and carbon monoxide, are thus evolved, and the metal boils up violently, the oxide being effectually reduced. After the *poled* metal has remained quiescent for a few minutes a sample is removed by the refiner, cast into a mould, and the casting first half cut through with a cold chisel, and then bent backwards and forwards until the piece breaks off. From the appearance and colour of the fractured surface an experienced eye can at once decide whether the copper has arrived at what is termed the *tough-pitch*. When this is reached, the charge must be withdrawn from the furnace as rapidly as possible and cast into iron moulds, in order to prevent a second oxidation occurring. Sometimes the molten metal becomes what is called *over-poled*, and if this be the case the metal must be exposed to the air for a short time to bring it back again to the tough-pitch.

Figs. 91 and 92 show the construction of a melting-furnace with a gas-generator (A) fired with coal which is filled from the shaft (c). The air necessary for the combustion of the generated gas is admitted by the opening (b b), whilst that required for the oxidation of the charge enters by the openings (K K).

The subject of the toughening of copper and of the removal of the non-metallic impurities contained in commercial copper, is somewhat complex, and has received much attention from metallurgists. From the experiments of Abel¹ it appears that toughened copper always contains a certain amount of oxygen present as suboxide, and this agrees with the observation of copper-smelters, who find that the whole batch may become over-poled in a few seconds, this being explained by the fact that the whole of the oxygen has been withdrawn. According to

¹ *Journ. Chem. Soc.* [2] ii, p. 172.

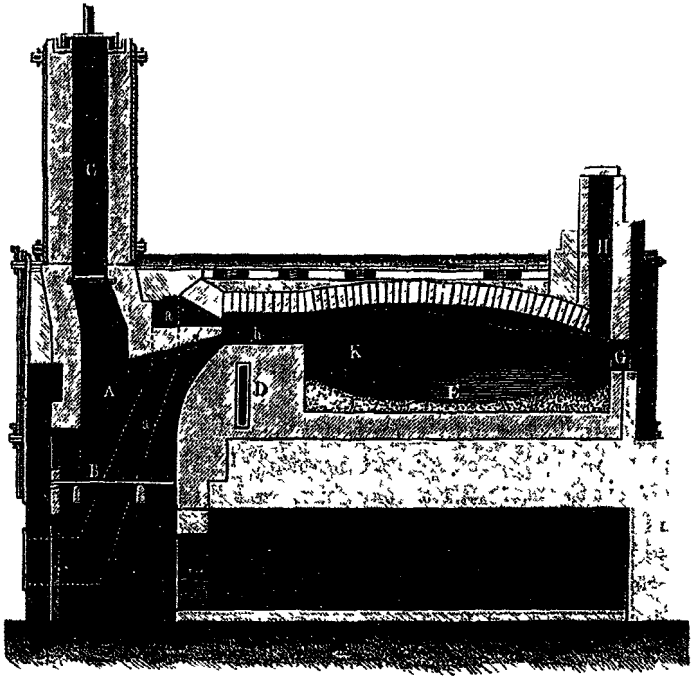
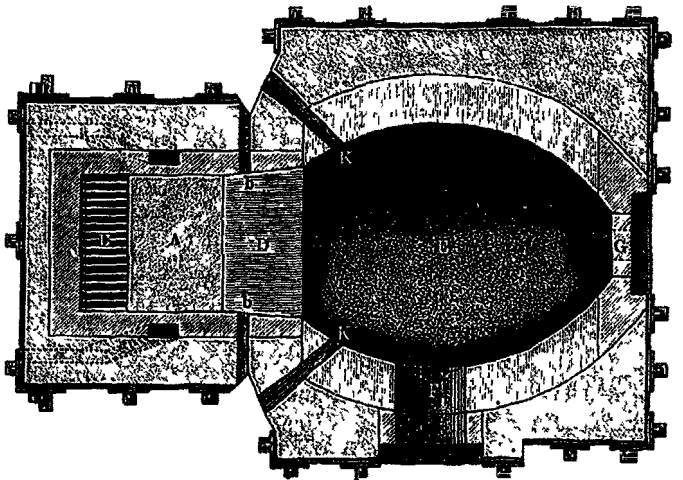

FIG. 91.



Dm 10 5 0 1 2 3 4 Meter

FIG. 92.

Hampe,¹ on the other hand, the phenomenon of over-poled copper depends partly on the absorption of carbon monoxide and hydrocarbons, and especially on the reduction of small quantities of lead oxide and bismuth oxide, which the copper contains, so that if these bodies are not present no over-poling occurs.

From the foregoing it will be seen, that there are at least six operations in the English system of copper-smelting, which may be summarized as follows :—

- Operation 1.—Roasting the mixed ores.
 „ 2.—Fusion of roasted ores yielding *coarse metal*.
 „ 3.—Roasting of coarse metal.
 „ 4.—Fusion of roasted coarse metal yielding *white metal*.
 „ 5.—Roasting of white metal yielding *blister-copper*.
 „ 6.—Refining and toughening of the blistered copper yielding *marketable copper*.

When copper is intended for rolling, it has long been the practice to add a little lead to the tough-pitch metal, and it has recently been proposed to improve the condition of marketable copper by adding to it an alloy of phosphorus containing 7 per cent. of the latter element; this alloy being added to the metal in the proportion of 1 to 100.

181 Large quantities of copper regulus and of blister-copper are now brought into this country from Chili, where the rich Chilian ores are smelted. The process of smelting adopted there is somewhat simpler than the English plan, as it consists in three operations only; viz. (1) fusion of the ore for coarse metal or regulus; (2) roasting this coarse metal yielding a spongy regulus; (3) roasting this, as in process 5 of the English system, to yield blister-copper.

The whole of the sulphur contained in the copper ore comes off in the processes of roasting in the form of sulphur oxides, and in most cases all this gas is discharged into the atmosphere from the chimneys of the copper-works. This copper-smoke has long been a source of a damage and annoyance to those residing in the neighbourhood of the smelting-works, and many attempts have been made to abate the nuisance by endeavouring to condense the fumes, which not only contain large quantities of

¹ *Chem. Centralblatt*, 1873, p. 378.

sulphurous and sulphuric acids, but likewise arsenic trioxide and sometimes hydrofluoric acid. The passage into the air of arsenic trioxide, and of dust containing copper and other matters, may be almost entirely avoided by allowing the furnace gases to pass through long and wide flues before they reach the stack. But

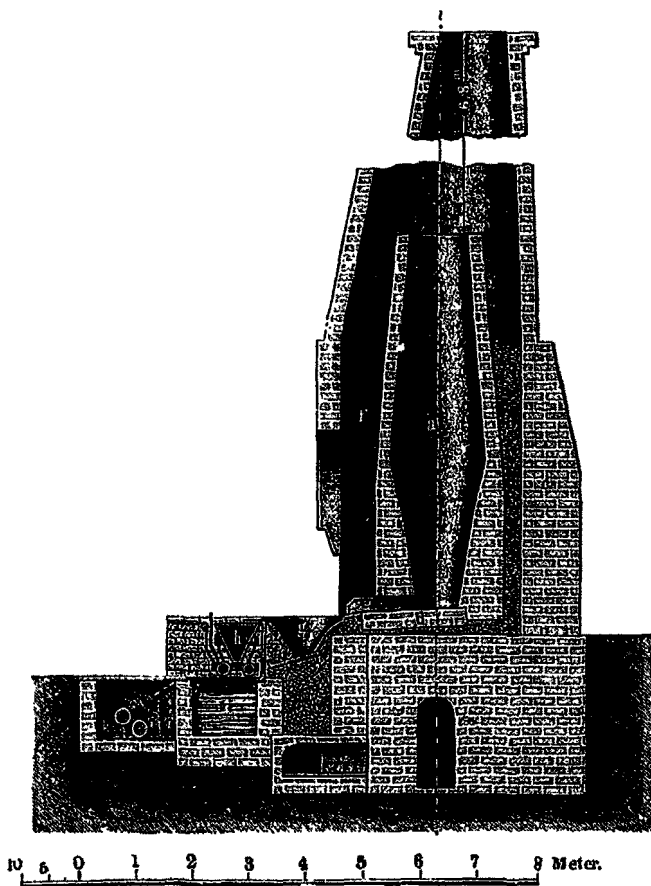

FIG. 93.

the acid vapours cannot thus be condensed. For this purpose the gases from the roasters may be passed into ordinary leaden sulphuric acid chambers, together with steam and nitrous fumes, and thus the sulphur dioxide condensed to marketable oil of vitriol. This process is now carried out by some few copper

smelters, especially by Messrs. Vivian at the Hafod works, and by Messrs. Newton, Keates, and Co. at St. Helens. It is, however, as yet found impossible thus to condense more than about 40 per cent. of the total sulphur gases sent off during the processes of copper-smelting, for in certain of the operations, as in the roasting of the white metal to yield blister-copper, the temperature required to bring about the reaction is so high, and therefore the dilution of the acid gases with air so great, that it has not been possible to make vitriol with this product. Nevertheless, by the adoption of measures already shown to be feasible, much of the nuisance and damage caused by copper-smoke can be prevented.

182 *The Mansfeld process of Copper-smelting.*—The well-known cuprous schist or kupferschiefer of the Germans, has been worked for copper for a long time. Agricola, writing in the middle of the sixteenth century, describes the methods adopted in his time near

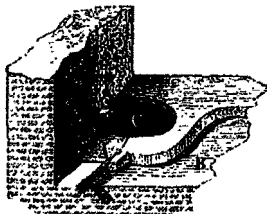

FIG. 94.

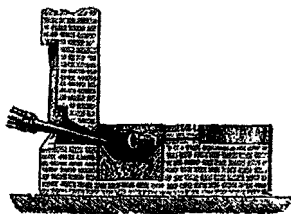

FIG. 95.

Mansfeld for the extraction of the metal. The first operation consists in the roasting or burning of the schist in heaps. In this process the bituminous matter is burnt off, the water and arsenic expelled, and a portion of the sulphur got rid of. In process No. 2, the roasted ore is mixed with about from 5 to 8 per cent. of slag and fluor-spar, the yield being coarse metal and slag containing very little copper. This operation is conducted in a blast-furnace or cupola from sixteen to thirty feet in height, supplied by air from two tuyeres, and the coarse metal, as it forms, runs out of the furnace into basins placed to receive it. The coarse metal, or "rohstein," containing from 20 to 60 per cent. of copper according to the nature of the ore, is next roasted, and the calcined ore melted for fine metal, or "spurstein."

The Mansfeld ores contain silver, usually about 0.5 to 100 of copper, and this is well worth extraction. In order to effect this, the fine metal is ground between mill-stones, and the powder

carefully roasted. In this process the copper is mainly converted into an insoluble oxide, whilst the silver is all transformed into the soluble sulphate, and can be completely extracted by lixiviation (Ziervogel). The insoluble copper oxide and sulphide

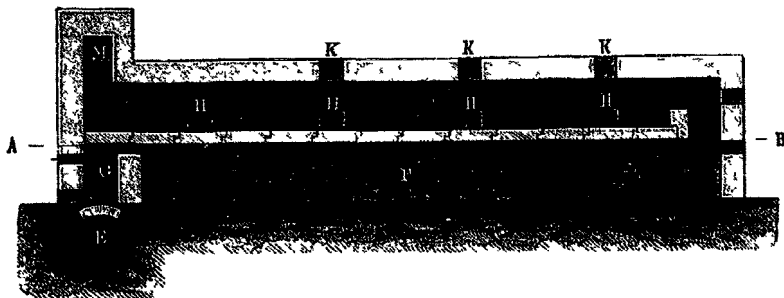

FIG. 96.

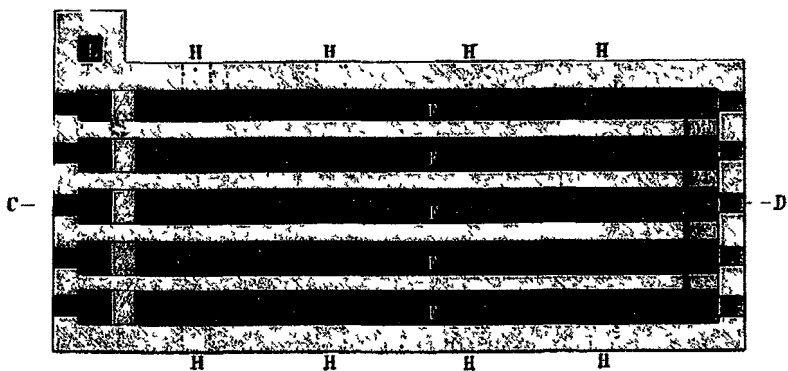

FIG. 97.

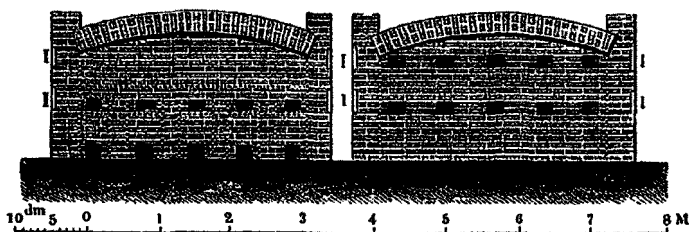

FIG. 98.

FIG. 99.

termed "gaarrost" is then fused with slag in a blast-furnace, closely resembling that shown in Fig. 93, and a rich regulus of black copper is obtained ; it contains about 98 per cent. of copper, the

remainder consisting of iron together with small quantities of silver and antimony. The black copper is lastly refined in a small furnace termed a refining hearth (Figs. 94 and 95), in which the impure metal is melted in contact with charcoal, a blast of air being supplied by the tuyeres, and samples of the metal being withdrawn from time to time to ascertain when the process is complete. The "rosette copper" thus obtained is, however, not of the highest quality, and it must be subjected to a process of toughening in order to enable it to attain its maximum degree of malleability.

183 *Wet Copper Extraction Process.*—No less than 500,000 tons of iron pyrites, containing on an average 3 per cent. of copper, are annually burnt in the sulphuric acid works of this country. The residual oxide of iron, known as burnt pyrites, or *blue billy*, is too poor in copper to render it possible to apply to it any of the ordinary dry-smelting operations. Processes for accomplishing this end have been proposed by Mr. Longmaid and Mr. Henderson, and are now carried out on a large scale, and known as the wet copper extraction processes. These operations depend upon the fact that if the ground-burnt ore be mixed with from 12 to 15 per cent. of coarsely crushed rock-salt, and the mixture properly calcined, the whole of the copper is converted into a soluble cupric chloride. The roasted mass is then lixiviated, and the copper contained in solution thrown down as metal by scrap-iron. The calcination is usually carried on in long furnaces shown in Figs. 96, 97, 98, and 99, the mixture of ore and salt being introduced through hoppers placed above the furnace; the temperature is kept at a dull red-heat and the mass frequently stirred. The ordinary furnace charge is 3 tons 5 cwts., and the operation lasts about six hours. It is found that the success of the working of the process depends upon the relative amounts of sulphur and copper existing in the ore, the sulphur exceeding the copper by about a half per cent. If the proportion of sulphur in the burnt ore be less than this, a sufficient quantity of raw pyrites must be added. During the calcination considerable quantities of chlorine and hydrochloric acid gases are evolved, together with some vapours of ferric and cupric chlorides. In order to prevent these noxious vapours from passing into the atmosphere, the exit flue from the furnace is connected with a wash-tower filled with open brickwork, down which a current of water passes. The precipitate of metallic copper, thrown down from the liquors by scrap-iron,

contains from 70 to 80 per cent. of copper, and it is either smelted directly for blister-copper, or fused with the fine metal, Cu_2S , of the dry process, then roasted, and afterwards worked up to marketable copper by the process already described.

184 Another extraction process is that of Hunt and Douglas.¹ According to this process the ores containing carbonates or oxides are simply heated, whilst those containing sulphides must be roasted. The ore is then treated with a solution prepared by dissolving 120 parts of common salt or 112 parts of calcium chloride, and 280 parts of sulphate of iron in 1,000 parts of water, and then adding 200 parts of common salt. The process depends upon the fact that ferrous chloride, FeCl_2 , is thus formed, which in contact with common salt converts the copper oxides into chlorides. If cuprous oxide is present, metallic copper is at once precipitated:—



Cupric oxide is decomposed as follows:—



Cuprous chloride being insoluble in water is held in solution in the presence of the other chlorides, and then decomposed by iron together with the cupric chloride.

185 *Properties of Copper.*—Commercial copper usually contains traces of the other metals which are present in the ores, and in addition to these not unfrequently arsenic, sulphur, and oxygen. Pure metallic copper is obtained either by heating the pure oxide in oxygen, or by the electrolysis of a solution of pure copper sulphate by means of platinum electrodes.

Copper possesses a peculiar red colour and bright metallic lustre. The true copper-red colour is, however, not seen by a single reflection, and is only observed when the light entering the eye has been many times reflected from the surface of the copper. This is well seen if a piece of straight copper foil be bent at an acute angle and held before the observer; the fine deep red copper colour is noticed near the point at which the two copper surfaces approach.

Copper is found crystallized in the native state in regular octohedrons; crystals of the same form are also found as an artificial refinery product. If a piece of phosphorus be allowed

¹ *Engineering*, xxii. p. 419.

to remain for some months in contact with a clean copper wire under a solution of copper sulphate, single octohedrons of metallic copper are formed together with copper phosphide (Wöhler), and a similar artificial formation of crystallized copper is observed in Golding-Bird's decomposing cell,¹ as well as in the cells of Meidinger's battery. In both these cases the metal is deposited from solution very slowly.

Copper is one of the toughest of metals. It is very malleable, and may be hammered or rolled into thin leaf (Dutch metal), or drawn into fine wire. After hammering it possesses a finely fibrous or silky fracture. Very slight admixture of other metals makes it more brittle, and imparts to it a less distinctly fibrous fracture. Native copper has a specific gravity of 8.94; cast copper, probably because it always contains small cavities, has a specific gravity of 8.92; the rolled or hammered copper 8.95; and pure electrolytic copper 8.945 (Hampe). Very thin copper leaf transmits a greenish-blue light. When a solution of copper sulphate is allowed to remain in contact with pure zinc, pure metallic copper is deposited as a fine spongy mass, which after washing and drying forms a soft impalpable dark-red powder.

The melting-point of copper is lower than that of gold but higher than that of silver. In the molten state it possesses a greenish-blue colour. When heated at a temperature just below that of its melting-point copper becomes so brittle that it can be pounded in a mortar. On passing from the liquid to the solid state copper expands. Molten copper possesses the power of absorbing different gases, which are evolved in the form of bubbles when the metal cools, or give rise to the peculiar phenomenon known as "spitting," when a solid crust has already been formed on the surface. Spongy copper absorbs at a red-heat 0.6 times its volume of hydrogen, whilst copper wire absorbs 0.308 times its volume (Graham). Copper can be distilled in a stream of hydrogen at the temperature of the electric arc.

Metallic copper is largely used for a great variety of technical and domestic purposes, being especially valuable from its toughness, as in the manufacture of tubular boilers. Next to silver, copper is the best conductor of electricity, and hence pure copper is employed for the wires of submarine telegraphs.

¹ *Phil. Trans.* 1831, p. 37.

ELECTROTYPING PROCESS.

186 It has already been stated that when copper sulphate undergoes electrolysis, metallic copper is deposited on the negative, and oxygen and sulphuric acid separated on the positive pole, that is, if the poles consist of platinum or other metal which does not undergo oxidation. If, however, copper poles be employed as electrodes no oxygen is evolved; the positive pole is gradually dissolved and an equal quantity of copper is deposited upon the negative pole. In the year 1836 De la Rue, when using a Daniells' battery, observed "that the copper plate is covered with a coating of metallic copper which is continually being deposited; and so perfect is the sheet of copper thus formed, that on being stripped off it has the counterpart of every scratch of the plate on which it is deposited."¹ This observation was followed up by other physicists, and in 1839 Professor Jacobi of St. Petersburg published his galvano-plastic process, "a method of converting any line however fine, engraved on copper, into a relief by galvanic process, applicable to copper-plate engravings, medals, stereotype plates, ornaments, and to making calico-printing blocks and patterns for paper-hanging."² In the same year Mr. T. Spencer of Liverpool read a paper on the "Electrotype Process," to the Liverpool Polytechnic Society, and also in 1839 Mr. J. C. Jordan published results of experiments made with the same object.³

Electrotyping in copper has become a most important branch of industry, statues and other works of art being in this way largely reproduced. Several of these made by this process in the celebrated works of Messrs. Elkington of Birmingham, and Messrs. Christophle of Paris, have attained colossal proportions.

For the purpose of obtaining electrotype copies of statues, busts, or similar objects, casts of the original in gypsum, or models in gutta-percha, must be obtained, and the surface of these saturated with linseed-oil or beeswax, and then carefully coated with graphite so as to give its surface the necessary conducting power. A number of "guiding wires" are then attached connected with all the most hollow or distant parts so as to

¹ *Phil. Mag.* [3] p. 484.

² *Athenæum*, May 4, 1839.

³ For a detailed account of these discoveries, see Grove's *Art of Electro-Metallurgy*.

obtain simultaneous and equal deposition of metal over the whole surface, and the object is then immersed in a copper sulphate solution and made the negative pole of a galvanic battery of the requisite strength. The whole then soon becomes coated with a thin film of copper; and the deposition is allowed to go on until this coating acquires a thickness of about $\frac{1}{16}$ of an inch, being then of sufficient strength to retain its form when the mould is removed. It is now lifted out of the vat, the copper cut through at suitable places, the plaster core broken away with great care and the whole of it extracted. The outer surface of the copper form with the wires attached to it is next thoroughly varnished over in order to prevent any deposit forming thereon. The inner surface, or the impression of the object, is now exposed to the action of sulphuretted hydrogen or dipped into a weak solution of potassium sulphide for the purpose of preventing adhesion of the subsequent deposit. Then the parts are again immersed in the depositing vat; this is filled with the copper solution; and a plate of pure electrotype copper is suspended within each portion and attached to the positive pole. A deposit of pure copper is now formed over the interior and this process is continued until the metal has attained a thickness varying from one-eighth to one-third of an inch, requiring a period of from three to four weeks. Each piece is now removed from the liquid, washed, and the thin outer first shell of copper torn off; then all the parts of the figure are nearly complete and ready for fixing together.

The method for the reproduction of fruit, flowers, insects, &c., in copper may here be mentioned. For this purpose articles of this kind, which are so fragile that they will scarcely bear handling, are first coated with silver by means of a saturated solution of silver nitrate in hot alcohol; the articles are dipped for a moment into this solution, the alcohol evaporates and the film of the salt left upon the object is reduced to metal by bringing it into the vapour emitted by a solution of phosphorus in carbon disulphide. The articles are then coated in a solution of copper sulphate by the method already described.

For the purpose of covering iron, an alkaline solution of copper cyanide in potassium cyanide is employed. On dipping the iron or steel article into this solution a thin deposit of copper is obtained, and upon this a coating of silver or gold can easily be deposited. For the purpose of obtaining a thicker deposit of copper on iron, the operation is conducted as described

and the object then placed in a copper sulphate depositing bath. An improvement upon this process has been made by Mr. H. Wilde of Manchester, by keeping the solution of copper sulphate in a constant state of rotation; by this means powerful electric currents may be brought to bear upon small surfaces of the metal without detriment to the quality of the deposited copper, the quantity of copper which can be thus deposited in the firmly coherent state is one pound per hour on the square foot of surface, this being twenty times greater than when the solution is allowed to remain at rest. The same observer notices that if the iron be heated to a temperature of 90° before it is dipped into the warm solution of cyanide, no hydrogen is deposited with the copper, as is the case in the ordinary process, and hence the metal adheres much more closely to the iron. These improvements are now successfully applied to the economical production of coppered cast-iron rollers for calico-printing. When a new pattern is required on the roller one-half of the copper is turned off and restored to its original thickness by deposit at a small cost. The maintenance of the rollers to a standard size is an important advantage.

An important branch of electrotyping, is that by which woodcuts can be copied and their number thus indefinitely increased. This is accomplished by obtaining a reverse of the wood-cut in gutta-percha softened in hot water; the cast thus obtained is then covered with finely divided graphite powder and placed as the negative pole of a battery and allowed to remain in the copper solution until the metal is deposited in a film of sufficient thickness. It is then taken out, and, to give it the requisite solidity, the back of it is filled with molten type-metal or with fusible solder. In the same way engravings from either steel or copper plates may be copied, and the same process can be applied to type-metal, the galvano-plastic being used in some cases in preference to the stereotype-process.

187 Copper Alloys.—Many alloys of copper are of great technical importance. We shall here mention only the copper-zinc alloys.

Brass, which has long been known, was up to the year 1780 always made by strongly heating copper together with calamine and charcoal or coal. The coal reduces the calamine to the metallic condition, and the zinc, instead of passing off as vapour, combines with the copper, and forms brass. At the present day, however, brass is prepared by adding

the requisite quantity of metallic zinc to molten copper. The composition of brass varies considerably; common brass, sometimes termed English brass, contains about two parts of copper to one of zinc. When more copper is added the colour becomes reddish. That containing about 80 per cent. of copper is termed German or Dutch brass or tombac. On the other hand, an additional proportion of zinc yields a light yellow metal known as Muntz metal, an alloy which was first prepared by Mr. Muntz, in the year 1832, and has since been very largely used for the sheathing of ships. Another such alloy named Aich's metal from its inventor, is malleable when hot.

The following table gives the composition of a variety of copper-zinc alloys:—

	Gold-like alloy used by Watch-makers.	Aich's metal.	Brass from			Tombac		Roman coin of the reign of Titus.
			Ocker.	Stöllberg.	England.	English.	Viennese.	
Copper	58·86	60·20	62·24	65·80	70·30	86·38	97·8	96·06
Zinc ...	40·22	38·10	37·27	33·80	29·30	13·61	2·2	2·71
Tin ...	—	—	0·12	0·25	0·17	—	—	—
Lead ...	1·90	—	0·59	0·28	0·28	—	—	—
Iron ...	—	1·60	0·12	—	—	—	—	0·85
	100·98	99·90	100·44	100·13	100·05	99·99	100·0	99·62

Brass and the other copper-zinc alloys are all harder than copper: they are malleable and can be hammered and rolled into thin plates and drawn out to fine wire; they can also be readily worked in the lathe. These properties, as well as its beautiful colour, bright lustre, and cheapness, render it an alloy most useful in the arts and manufactures.

COPPER AND HYDROGEN.

188 *Copper Hydride*, Cu_2H_2 . This compound discovered by Wurtz,¹ is deposited as a yellow or reddish-brown precipitate when a solution of copper sulphate is heated with hypophosphorous acid to a temperature not exceeding 70°. When raised to a higher temperature the hydride decomposes into its constituents. It ignites easily in chlorine gas, and is decomposed by hydrochloric acid as follows:—

¹ *Compt. Rend.* xviii. p. 102.

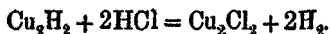

The same compound is also formed by the action of sodium hypophosphite on a solution of copper sulphate (Schützenberger).

COPPER AND OXYGEN.

189 These elements form four compounds as follows:—

Copper tetrantoxide, Cu_4O .

Copper hemioxide or cuprous oxide, Cu_2O .

Copper monoxide or cupric oxide, CuO .

Copper dioxide or cupric peroxide, CuO_2 .

Of these oxides the second and third have been long known, as they are formed when metallic copper is heated in the air. Copper scale, which falls from hot metallic copper when it is worked with the hammer, is a mixture of these two oxides. The portion of the scale next to the metal consists of the red cuprous oxide whilst the outside portion is composed of black cupric oxide. Dioscorides and Pliny mention the existence of the red compound, indeed they distinguished two varieties, the one obtained in the form of a finely divided powder by pouring water on to the surface of freshly melted copper and termed *flos aeris*, and the other obtained as copper scale and termed *aeris squama*. Geber explained the calcination of copper by the combustion of the sulphur which this metal was supposed to contain (Vol. I. p. 5), and many later chemists speak of copper as being more or less calxed. It was not, however, until the year 1798 that Proust distinctly stated that the black and red calces of copper were two distinct oxidation products.

Copper Tetrantoxide, Cu_4O , sometimes termed quadrantoxide, is formed, according to H. Rose,¹ by adding a solution of copper sulphate to a dilute solution of dichloride of tin and caustic potash keeping the mixture well cooled. Copper hydroxide, $\text{Cu}(\text{OH})_2$, is in this case first formed, and this is reduced by the tin dichloride with formation of potassium stannate:—

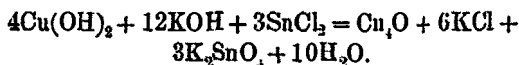

Copper tetrantoxide is an olive-green powder which undergoes no change under water if the air be completely excluded

¹ Pogg. Ann. cxx. 1.

Exposed to air it rapidly absorbs oxygen. The composition of this compound is ascertained from the action of dilute hydrochloric or sulphuric acid upon it, when the following decomposition takes place :—



Copper Hemioxide or *Cuprous Oxide*, Cu_2O . This oxide occurs as cuprite or red copper ore, crystallizing in octohedrons and in other simple or complex forms of the regular system. It possesses a bright red or brownish red colour, frequently exhibiting a diamond lustre; it also occurs in the massive state. In the mineral chalcotrichite it forms a hair-like mass consisting of small cubical crystals elongated in the direction of one of the axes. Pure cuprite has a specific gravity of 5·75.

Cuprous oxide can be obtained artificially in a variety of ways. Thus, if a thick copper wire be heated in a muffle for half an hour at a white-heat, and then for some hours at a dark red-heat, small dark crystals of the oxide are seen to cover the surface of the metallic bead obtained (Marchand). Finely divided copper is, however, converted into cuprous oxide at a temperature below a red-heat, and if the metallic powder has been obtained by reduction in hydrogen at the lowest possible temperature, it combines with atmospheric oxygen on exposure to air at the ordinary temperature. A solution of copper sulphate to which an excess of caustic soda has been added yields a blue solution with sugar, and this, when gently heated, deposits a fine red precipitate of cuprous oxide, consisting of microscopic crystals (Mitscherlich). It is obtained as a non-crystalline red powder by gently heating a mixture of five parts of cuprous chloride and three parts of sodium carbonate, in a covered crucible and lixiviating the residue. Cuprous oxide is also formed by the slow oxidation of the metal under water. Sage, in the year 1773, pointed out that the remains of a statue which had long lain under water were partially converted into this oxide, and J. Davy observed that an antique helmet found in the sea near Corfu, was covered with crystals of metallic copper as well as of cuprous oxide. It has also been obtained in the crystalline state by the slow galvanic decomposition of copper sulphate.¹

¹ Golding-Bird, *Phil. Trans.* 1837, p. 37.

Commercial cuprous oxide has a specific gravity of from 3.34 to 3.37, and the more finely it is divided the finer red does its colour become. It fuses at a red-heat and colours glass red. This latter property was known to the ancients, and in the middle ages many artificers understood the art of producing the red copper glass. The knowledge of this process was, however, completely lost in later times, and it was not until about the year 1827, that Bontemps in France and Engelhardt in Germany succeeded in imitating this ancient red glass.

Cuprous Hydroxide, $\text{Cu}_2\text{O}_3(\text{OH})_2 = 4\text{Cu}_2\text{O} + \text{H}_2\text{O}$, falls as a bright yellow precipitate when cuprous chloride is decomposed by potash or soda. This precipitate contains only three per cent. of water which cannot be driven off below 360° . The hydroxide easily absorbs oxygen and becomes of a blue colour when exposed to the air. It dissolves in ammonia, as does cuprous oxide itself, forming a colourless liquid, which, on exposure to the air, quickly oxidises and becomes of a dark blue colour.

190 *Copper Monoxide* or *Cupric Oxide*, CuO . This substance occurs as black oxide of copper or melaconite as a dark earthy mass or in bright lustrous laminae and more rarely in cubes. It can be artificially produced by the gentle ignition of the nitrate, carbonate, or hydroxide. Thus obtained it is a black powder which cakes together when more strongly heated, and fuses when the temperature is raised to the melting-point of copper. In this act 8.1 per cent. of oxygen is evolved and an oxide remains behind which has the composition $\text{Cu}_5\text{O}_3 = \text{CuO} + 2\text{Cu}_2\text{O}$. If the amorphous oxide be ignited with five times its weight of caustic potash it becomes crystalline, and regular tetrahedrons possessing a metallic lustre are formed (Becquerel). In copper refineries the occurrence of a crystalline oxide has also been observed. Copper oxide is extremely hygroscopic and slightly volatile at the highest temperature of a wind-furnace. When heated in the presence of hydrogen, carbon monoxide, marsh-gas, and other carbon compounds, it is easily reduced to the metallic state with formation of water and carbon dioxide, and hence it is largely used in the ultimate analysis of organic compounds. Cupric oxide when brought in contact with fused glass imparts to it a fine light-green colour; this was known to the ancients as well as to the later alchemists who rediscovered the fact, and found that artificial emeralds could be prepared by means of copper. Basil Valentine says "the emerald contains sulphur

veneris," and the writers of the sixteenth century who treat of the artificial production of gems all mention the fact that copper calx colours glass green.

Cupric Hydroxide, $\text{Cu}(\text{OH})_2$, is obtained as a light blue precipitate by decomposing a solution of a copper salt in the cold with an alkali. This precipitate, however, almost always contains a considerable quantity of alkali, and the hydroxide is obtained in a purer state by adding sal-ammoniac to the solution before precipitation, and then washing the precipitate well with warm water. The compound, after having been dried over lime, does not undergo loss of water on heating to 100° , but if the freshly precipitated oxide be boiled with water it soon becomes black being converted into a hydrate having the composition $\text{Cu}_2\text{O}_2(\text{OH})_2 = \text{Cu}(\text{OH})_2 + 2\text{CuO}$. Copper hydroxide dissolves readily in aqueous ammonia yielding a beautiful dark blue liquid which is also produced when copper is allowed to remain in contact with aqueous ammonia, and the liquid exposed to the air. When largely diluted with water or treated with strong caustic potash, cupric hydroxide separates out from the solution, and on heating this, the black hydrate is precipitated. The solution of copper oxide in ammonia possesses the property of dissolving cellulose (cotton-wool, linen, filter-paper, &c.).¹

Malaguti and Sarzeau by evaporating a solution of cuprammonium chromate obtained a mass of dark blue needles having the composition $4\text{NH}_3 + 3\text{Cu}(\text{OH})_2 + 3\text{H}_2\text{O}$. These glow when heated, metallic copper being left behind.²

Copper Dioxide, $\text{CuO}_2 \cdot \text{H}_2\text{O}$, is formed, according to Thénard, by the action of dilute hydrogen dioxide on copper hydroxide at the temperature of the freezing-point. It is a yellowish brown powder which very readily decomposes into cupric oxide and oxygen.

SALTS OF COPPER.

191 Two series of copper salts are known corresponding to cuprous and cupric oxide.

THE CUPROUS SALTS,

But few of these salts are known in the pure state, cuprous oxide being converted by the action of most acids either into

¹ Schweizer, *Journ. Pract. Chem.* lxxii. 109.

² *Ann. Chem. Phys.* [3] ix. 438.

metal and the monoxide which dissolves, or completely oxidised into the latter compound.

Cuprous Chloride, Cu_2Cl_2 .—This substance was first obtained by Boyle¹ by the action of copper on mercuric chloride. He compared the substance thus obtained, which he found turned green on exposure to air, to resin or gum, and hence he gave to it the name of *resina cupri* or *cuprum gummatosum*. Proust obtained the same compound by the action of the dichloride on the salts of the monoxide, and J. Davy showed that cuprous chloride is formed together with the cupric salt when copper foil or copper filings are thrown into chlorine gas, when they burn with the evolution of a red light. If hydrochloric acid be passed over hot copper contained in a glass tube this compound is formed, and is seen to condense in transparent drops (Wöhler). In order to prepare it on a large scale, cupric chloride is boiled with hydrochloric acid and copper filings or precipitated copper, a few pieces of scrap platinum being added. The filtered solution yields on the addition of water a white crystalline precipitate of cuprous chloride. This, on exposure to light in the moist state soon becomes of a dirty violet tint, but if it be dried in absence of air or light it then assumes only a faint yellow colour on exposure to light. It crystallizes from hot concentrated hydrochloric acid in the form of white regular tetrahedrons. Cuprous chloride may also be obtained by gradually adding a few crystals of potassium chlorate to a mixture of hydrochloric acid and copper turnings until nearly all the copper is dissolved, when the solution is poured into water.² Another process consists in adding an intimate mixture of two parts of copper oxide and one part of zinc-dust in small quantities at a time to common strong hydrochloric acid until cuprous chloride begins to separate out; more hydrochloric acid is then poured in and more of the mixture added until a sufficient quantity of the compound is formed. The precipitate is then allowed to settle and the cuprous chloride precipitated by pouring the clear solution into water.³

Cuprous chloride has a specific gravity of 3.7; it melts below a red-heat, solidifying to a yellowish or brownish mass. Exposed to the air it absorbs water and oxygen and is converted into

¹ *Considerations and Experiments about the Origin of Qualities and Forms*, 1664.

² Lupton, *Chem. News*, xxx. 322.

³ Heumann, *Ber. Deutsch. Chem. Ges.* vii. 720.

green cupric oxychloride. The hydrochloric acid solution of cuprous chloride absorbs carbon monoxide forming a compound with it which separates out in scales having a mother-of-pearl lustre, on saturating the concentrated solution with the gas (Berthelot). This compound probably possesses the formula $\text{CO Cu}_2\text{Cl}_2 + 2\text{H}_2\text{O}$. Its composition has, however, not been definitely ascertained owing to the readiness with which it parts with carbon monoxide.

Cuprous Bromide, Cu_2Br_2 , is formed with ignition when bromine is brought into contact with copper heated below a red-heat. It forms a brownish crystalline mass which turns blue on exposure to sunlight and has a specific gravity of 4.72.

Cuprous Iodide, Cu_2I_2 . This is the only known iodide of copper. It is obtained by the direct combination of the two elements being formed when they are heated together or when copper is dissolved in a hot concentrated solution of hydriodic acid. If potassium iodide be added to a solution of a cupric salt, cuprous iodide is precipitated, half of the iodine being liberated. The evolution of iodine can be prevented by the previous addition of sulphurous acid or ferrous sulphate:

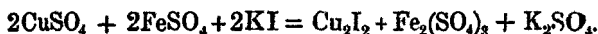

Cuprous iodide is a white crystalline powder which undergoes little alteration on exposure to light; and has a specific gravity of 4.41. It melts at a red-heat, solidifying again to form a brown mass which yields a green powder.

Cuprous Fluoride, Cu_2F_2 , is formed by the action of hydrofluoric acid upon cuprous hydroxide. It is a red powder which melts on heating to form a black liquid solidifying to a scarlet mass. It dissolves in concentrated hydrochloric acid with a black colour; on the addition of water it is precipitated as a white powder which soon assumes a red colour.

Cuprous Sulphite, $\text{Cu}_2\text{SO}_3 + \text{H}_2\text{O}$, is formed by passing sulphur dioxide into a mixture of water and ammonium cuprous sulphite; on crystallizing, the salt separates out in red rectangular prisms. When an excess of solution of ammonium sulphite is added to one of copper sulphate, a yellowish brown precipitate is first formed, but this disappears again on further addition of copper sulphate and on warming. The solution then deposits ammonium cuprous sulphite, $(\text{NH}_4)_2\text{SO}_3, \text{Cu}_2\text{SO}_3$, in the form of colourless six-sided scales. Another double salt, $(\text{NH}_4)_2\text{SO}_3, 2\text{Cu}_2\text{SO}_3$, is formed when a solution of copper sulphate is treated with a

large excess of ammonium sulphite and a sufficient quantity of sulphurous acid added to prevent the formation of a precipitate. If the solution be then allowed to stand in a closed vessel the above salt crystallizes out in bright white scales. The liquid on heating yields a bright red powder or scales of cupric-cuprosulphite, $\text{CuSO}_3 + \text{Cu}_2\text{SO}_3 + 2\text{H}_2\text{O}$.

Cuprous Cyanide, $\text{Cu}_2(\text{CN})_2$. When a solution of potassium cyanide is added to a solution of copper sulphate a red precipitate of cupric cyanide is first formed; cyanogen gas is given off when the liquid is boiled and a white precipitate of cuprous cyanide deposited. This same compound is formed by the action of potassium cyanide on cuprous chloride, and also by neutralizing aqueous hydrocyanic acid with potash and then adding a solution of copper sulphate and hydrochloric acid. This reaction may be employed for the detection of hydrocyanic acid (Lassaigne); it is however less characteristic than the other reactions for this acid, because hydriodic acid produces a similar precipitate of cuprous iodide.

Cuprous Thiocyanate, $\text{Cu}_2(\text{SCN})_2$. Potassium thiocyanate gives a black precipitate of cupric thiocyanate when added to a solution of copper sulphate. This on long standing and washing is converted into white cuprous thiocyanate. If a reducing agent such as ferrous sulphate or sulphur dioxide be present this latter compound is at once precipitated. This reaction is often employed for the separation of copper from other metals in quantitative analysis.

CUPRIC SALTS.

192 The anhydrous cupric salts are yellow or colourless; the hydrated salts green or blue. They combine with ammonia in different proportions forming peculiar compounds, of which many dissolve in water with a deep blue colour. The normal salts are generally soluble in water; the basic salts, on the other hand, are usually insoluble. All the copper salts are poisonous, causing vomiting; the soluble ones possess an unpleasant metallic taste and redden blue litmus paper.

Cupric Chloride, CuCl_2 , is formed when metallic copper is burnt in an excess of chlorine, or when the hydrated crystalline chloride is heated. Cupric chloride is a dark-liver coloured powder which on heating is converted into cuprous chloride

with loss of chlorine. It readily dissolves in water, forming a green liquid which is also obtained by dissolving the oxide or carbonate in hydrochloric acid. Rhombic prisms or needles having the composition $\text{CuCl}_2 + 2\text{H}_2\text{O}$ separate out on evaporation. The concentrated solution of the hydrated chloride has an emerald-green colour, and on dilution with water the colour changes to a bluish-green. It is very deliquescent and is soluble in alcohol, the solution burning with a fine green flame and giving a characteristic channelled-space spectrum.

Basic Cupric Chloride, or *Copper Oxychloride*, $\text{Cu}_3\text{O}_2\text{Cl}_2 + 4\text{H}_2\text{O} = 2\text{CuO} + \text{CuCl}_2 + 4\text{H}_2\text{O}$. This compound falls down as a pale blue precipitate when caustic potash is added to an excess of a solution of cupric chloride. When the compound is heated it loses water and is converted into a brown or blackish powder, and when moistened, this takes up three molecules of water and changes again to a green colour. When a solution of cupric chloride is mixed with cupric hydroxide, or when an excess of caustic potash is added to the solution of the former salt so as to ensure complete precipitation, a compound having the composition $\text{Cu}_4\text{O}_3\text{Cl}_2 + 4\text{H}_2\text{O}$ is thrown down. This substance occurs native in the form of a green sand composed of small rhombic prisms found at Atacama, as well as in Peru, Bolivia, and other places, and hence termed *atacamite*. According to Field, this mineral is at the present day being formed on the south coast of Chili by the action of sea-water on copper pyrites. The same compound may be artificially obtained in the crystalline state by heating common salt with ammoniacal solution of copper sulphate to 100° (Debray), the decomposition being:

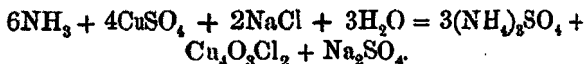

This compound is also formed when copper foil exposed to the air is repeatedly moistened with hydrochloric acid or chloride of ammonium solution, or when a solution of copper sulphate is boiled with a small quantity of bleaching-powder solution. The product obtained in the last process occurs in commerce as a light bright green powder, used in the arts as a pigment and known under the name of *Brunswick green*. On heating it loses water and becomes black but regains the green colour on moistening. Other oxychlorides of copper are also known occurring partly as minerals and partly as artificial products.

Cupric Chloride and Ammonia. Anhydrous cupric chloride absorbs ammonia, increasing in bulk and forming a blue powder having the composition $\text{CuCl}_2 + 6\text{NH}_3$. When ammonia gas is passed into a hot saturated solution of copper chloride a dark blue solution is formed which on cooling deposits small dark blue octohedrons or pointed quadratic prisms having the composition $\text{CuCl}_2 + 4\text{NH}_3 + \text{H}_2\text{O}$. Both compounds yield a green powder when they are heated to 150° , having the composition $\text{CuCl}_2 + 2\text{NH}_3$; at higher temperatures nitrogen, ammonia, and sal-ammoniac are given off whilst cuprous chloride remains behind:

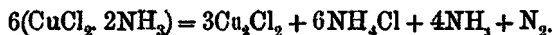

The action of water on this substance is to decompose it into the foregoing compound which remains in solution, and into an oxychloride having the composition $\text{Cu}_6\text{O}_4\text{Cl}_2 + 6\text{H}_2\text{O}$, which remains behind as a bluish-green powder.

Cupric Bromide, CuBr_2 . When cupric oxide is dissolved in hydrobromic acid and the solution allowed to stand in a vacuum over sulphuric acid, the anhydrous bromide separates out in dark crystals very similar to those of iodine. These are very deliquescent and on heating in absence of air decompose into cuprous bromide and bromine.

Cupric Fluoride, $\text{CuF}_2 + 2\text{H}_2\text{O}$, is formed by dissolving the monoxide in hydrofluoric acid. On evaporation small transparent blue crystals slightly soluble in cold water separate out. These are decomposed at 100° with the separation of light green oxyfluoride, $\text{Cu}(\text{OH})_2$, CuF_2 .

193 *Cupric Sulphate or Copper Sulphate, CuSO_4 .* This body has long been known under the name of blue-vitriol or copper-vitriol, being found in solution in the drainage-water of copper mines. Copper sulphate was for a long time confounded with green-vitriol or iron sulphate, this being partially due to the fact that both frequently appear in the same drainage-water and are capable of crystallizing together. Basil Valentine appears to have been the first to recognise the fact that both iron and copper vitriol can occur together, for he says: "Venus and Mars can be brought back into a virtuous vitriol." The alchemists frequently experimented upon such mixed vitriols, as they believed that they contained the *materia prima* employed for the preparation of the philosopher's stone. Basil Valentine

says "where copper and iron are found together, there the seeds of gold will not be far distant."

The artificial production of copper sulphate is first described by Van Helmont in 1664. He obtained it by heating copper and sulphur together and moistening the residue with rain-water. Glauber, in 1648, proved that it may easily be obtained by boiling copper with oil of vitriol.

Copper sulphate is manufactured on the large scale in a variety of ways. In Lancashire it is prepared in quantity from roasted copper pyrites which is treated in leaden pans with chamber-acid and steam, the copper oxide dissolving and the iron oxide remaining to a great extent unacted upon. When copper ores containing sulphur are carefully roasted the copper sulphide is converted into copper sulphate, the iron sulphide being chiefly converted into oxide. By lixiviating the residue a solution of copper sulphate tolerably free from iron is obtained and this may be purified by crystallization from the concentrated liquor. The mother-liquors of the solution of copper sulphate obtained in both these ways contain iron sulphate together with copper sulphate, and from these the copper is generally separated by precipitation on iron plates. This precipitated copper, as well as copper scale, and metallic copper obtained by other processes, is used for the manufacture of copper sulphate by roasting in reverberatory furnaces and dissolving the product in dilute sulphuric acid. In case the metallic copper or the copper ores contain gold or silver as is the case with that from the Harz, the granular metal is treated in wooden vessels with dilute sulphuric acid, which dissolves the copper and leaves the gold and silver undissolved. This simple process, which was first carried out at Mansfeld, is now generally employed not only to separate other metals from copper but for the purpose of working up the various copper residues for blue-vitriol.

194 The following process is adopted in Lancashire for the preparation of sulphate of copper from argentiferous copper ores. The ore is first oxidized by roasting in reverberatory furnaces. The ground and roasted ore is then digested in leaden vessels with sulphuric acid, the ore being added in small quantities at a time. Nearly the whole of the copper dissolves as copper sulphate together with a portion of the silver, arsenic, antimony, and bismuth which the ore contains, whilst the lead, a portion of the copper, and the gold, are thrown down. The addition of ore is repeated until the solution is nearly neutral, or

contains as little free acid as possible. The solution is next boiled down to the crystallizing point and then run into large tanks lined with lead, in which strips of metallic copper are hung. Upon this metallic copper the whole of the silver and a portion of the antimony and arsenic are deposited in the metallic state. A considerable quantity of the bismuth separates out as an insoluble basic sulphate, and any iron present is reduced to ferrous salt. The copper sulphate solution, thus freed from other metals, is then crystallized in similar large lead-lined coolers being deposited upon strips of lead hung up in the cooler. The crystals after standing are removed as a marketable article. The mother-liquors pass back again to be mixed with sulphuric acid and fresh copper ore and are thus worked again. After a time the liquors become too rich in iron to be used for the preparation of the pure sulphate; they are then neutralized with spent pyrites and boiled down; the crystals thus formed of the mixed sulphates of iron and copper are sold as agricultural sulphate of copper.

Cupric sulphate is also obtained as a secondary product in the refining of silver; the silver is precipitated from solution of the sulphate in the metallic form by a piece of copper and pure cupric sulphate remains behind.

195 Copper sulphate crystallizes from warm saturated solution on cooling in transparent blue triclinic crystals (Fig. 100) having the formula $\text{CuSO}_4 + 5\text{H}_2\text{O}$ and a specific gravity of 2.28. 100 parts of water dissolve, according to Poggiale, as follows:—

	At	10°	20°	30°	50°	70°	80°	100°
$\text{CuSO}_4 + 5\text{H}_2\text{O}$		36.59	42.31	48.81	65.83	94.60	156.44	203.32.

The salt is insoluble in absolute alcohol and only slightly soluble in dilute spirits. When it is heated for some time to 100° the hydrate $\text{CuSO}_4 + \text{H}_2\text{O}$ remains as a bluish-white powder, which at a temperature of from 220° to 240° loses an additional molecule of water leaving the anhydrous salt behind. This forms a white mass which is extremely hygroscopic, becoming blue on absorption of water. This reaction is sometimes used for the purpose of ascertaining the presence of water in organic

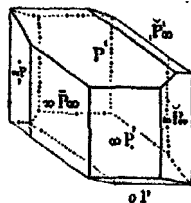

FIG. 100.

liquids, as also for dehydrating the same. The anhydrous compound may be obtained in the form of colourless crystals by

acting upon copper with concentrated sulphuric acid in closed vessels. The anhydrous as well as the hydrated sulphate absorbs two molecules of hydrochloric acid gas with evolution of heat and formation of cupric chloride and sulphuric acid. This same decomposition takes place when copper sulphate is treated with an excess of hydrochloric acid when the temperature sinks and the salts dissolve with formation of a green liquid which on concentration yields crystals of cupric chloride. This reaction of copper sulphate is employed for separating hydrochloric acids from mixtures of gas, as for instance, from chlorine or from carbon dioxide which has been prepared by means of hydrochloric acid. Copper sulphate is largely used in calico-printing, and in the preparation of the pigments of copper, as Scheele's green and emerald green. It is also used in very large quantity in the processes of electro-metallurgy.

Copper forms a series of basic sulphates. When the normal sulphate is kept for several hours at a dark red-heat an amorphous orange-yellow powder remains behind having the composition $\text{SO}_2 \left\langle \begin{array}{c} \text{O}-\text{Cu} \\ \text{O}-\text{Cu} \end{array} \right\rangle \text{O}$, which is decomposed in contact with cold water into copper sulphate and an insoluble green basic sulphate, $\text{CuSO}_4 + 3\text{Cu}(\text{OH})_2$. By the action of boiling water a salt having the composition $\text{CuSO}_4 + 2\text{Cu}(\text{OH})_2$ is formed. These as well as other basic salts are also obtained when a solution of copper sulphate is treated under certain conditions with potash or ammonia. Some occur as minerals; thus brochantite is a native basic sulphate having the formula $\text{CuSO}_4 + 3\text{Cu}(\text{OH})_2$, and occurring in bright green rhombic tables. It can be artificially prepared by allowing a piece of porous limestone to lie in a solution of copper sulphate.

Ammoniacal Compounds of Copper. When a solution of copper sulphate is treated with ammonia a basic sulphate is first thrown down. On further addition of ammonia this dissolves to a deep pure blue liquid containing the compound $\text{CuSO}_4 + 4\text{NH}_3 + \text{H}_2\text{O}$, which was first described by Stisser in 1693 as an *arcanum epilepticum* and afterwards termed *cuprum ammoniacale*. In order to obtain this compound in fine crystals a layer of strong alcohol is poured on to the concentrated aqueous solution and the whole allowed to stand: in this way azure blue transparent very long and thin rhombic prisms are deposited. These on exposure to the air lose ammonia and are gradually transformed into ammonium sulphate and basic copper sulphate. Heated gently

to 150° an apple-green powder of the composition $\text{CuSO}_4 + 2\text{NH}_3$ is obtained. Anhydrous copper sulphate absorbs dry ammonia gas with evolution of heat, forming a fine blue powder consisting of $\text{CuSO}_4 + 5\text{NH}_3$, which like the foregoing compound on heating to 200° forms the compound $\text{CuSO}_4 + \text{NH}_3$ (Graham).

196 Cupric Nitrate or Copper Nitrate, $\text{Cu}(\text{NO}_3)_2$. In his *Furnis novis philosophicis* published in 1648 Glauber mentions the fact that the solution of copper in nitric acid on evaporation leaves a green residue, and Boyle in 1664 observed that crystals can be obtained from the solution and that these have the power of colouring the flame of a spirit-lamp green. In order to prepare copper nitrate, copper scale or copper oxide is dissolved in dilute nitric acid and the solution evaporated to crystallization. In this way fine blue prismatic crystals, having the composition $\text{Cu}(\text{NO}_3)_2 + 3\text{H}_2\text{O}$ are obtained which possess a caustic metallic taste and cauterize the skin. At a very low temperature the salt crystallizes with six molecules of water. The anhydrous nitrate is not known, as the hydrated salt when heated to 65° begins to lose nitric acid, a basic salt having the composition $\text{Cu}(\text{NO}_3)_2 + 3\text{Cu}(\text{OH})_2$ being formed.¹ Copper nitrate is deliquescent and very soluble in water, and is deposited as a fine crystalline powder when its concentrated solution is mixed with nitric acid of specific gravity 1.522.² The salt, owing to the ease with which it is decomposed, possesses strong oxidizing properties. If paper be saturated with the solution of the nitrate it takes fire on warming, and if some crystals of the salt be wrapped up in tinfoil and rubbed, decomposition begins, often accompanied with a rise of temperature sufficient to cause emission of sparks.³ If a solution of copper nitrate be evaporated with one of ammonium nitrate decomposition takes place at a certain degree of concentration attended with violent detonations. Copper nitrate is used as an oxidizing agent in the processes of dyeing and calico-printing, especially in the production of catechu-browns, and in some steam colours containing logwood.

197 Phosphates of Copper.—*Normal Copper Phosphate, $\text{Cu}_3(\text{PO}_4)_2 + 3\text{H}_2\text{O}$,* is best obtained by dissolving the carbonate in dilute phosphoric acid and heating the solution to 70°, when a fine blue crystalline powder is deposited. On heating this with water in closed tubes it decomposes into phosphoric acid and a *basic salt*

¹ Graham, *Phil. Trans.* 1837, p. 57. ² Mitscherlich, *Pogg. Ann.* xviii. 159.

³ Higgins, *Crell's Chem. J.* i. 171.

$\text{PO}_4 \left\{ \begin{array}{l} \text{Cu} \\ \text{CuOH} \end{array} \right.$ (Debray), which latter occurs in nature as libethenite. The artificial compound crystallizes in rhombic prisms, and libethenite in dark olive-green prisms having a waxy lustre. The same compound also occurs in the massive state.

Another basic copper phosphate is the mineral phosphochalcite or pseudomalachite; this occurs in triclinic emerald green crystals having the composition $\text{PO}_4(\text{CuOH})_3$. Other basic phosphates of copper are known.

Arsenates of Copper. These salts correspond closely to the phosphates. Several basic salts occur in the mineral kingdom. The ortho-arsenate $\text{Cu}_3(\text{AsO}_4)_2 + 2\text{H}_2\text{O}$ is obtained as a blue amorphous powder by heating together copper nitrate and calcium arsenate. Olivenite, $\text{AsO}_4 \left\{ \begin{array}{l} \text{Cu} \\ \text{CuOH} \end{array} \right.$, crystallizes in olive-green or brown rhombic prisms, and can be obtained artificially by heating a solution of the ortho-arsenate to 100° .

Clinoclasic, $\text{AsO}_4(\text{CuOH})_3$, forms dark green monoclinic prisms possessing a pearly or vitreous to resinous lustre.

Copper Arsenite, CuHAsO_3 , was first obtained by Scheele by precipitating a solution of potassium arsenite with copper sulphate, and is still prepared by the same process. It is a siskin-green precipitate, which is known as a pigment under the name of *Scheele's green*. The salt dissolves in caustic potash with a blue colour and is then quickly decomposed on heating with separation of copper oxide.

198 *Silicates of Copper.* Two silicates of copper occur as minerals. Dioptase or emerald copper, H_2CuSiO_4 , is found in compact limestone in the Kirghese Steppes and also in Siberian gold-washings. It forms emerald-green crystals, assuming tetrahedral forms of the rhombic system and having a specific gravity of 3.3.

Chrysocolla, $\text{H}_2\text{CuSiO}_4 + \text{H}_2\text{O}$, exists as a bluish botryoidal mass occurring with other copper ores. The name of chrysocolla occurs in old writers and serves to describe the most diverse bodies. The word originally was used to signify the substance employed for soldering gold ($\chi\rho\upsilon\sigma\omicron\varsigma$, gold, and $\kappa\omicron\lambda\lambda\acute{\alpha}\omega$, to cement); and this being prepared from urine was probably microcosmic salt which became coloured blue in the act of soldering gold to copper or brass. The word then came to be used for any green or blue substance, especially such as contained copper; the confusion thus created was great, all blue or green

minerals, such as emerald and malachite, as well as substances which were employed for soldering, being termed chrysocolla. Brochant, in the year 1808, first proposed to confine the use of this name to the particular mineral.

199 Carbonates of Copper. We are only acquainted with basic copper carbonates. Of these two occur in large quantity in the mineral kingdom. Malachite, $\text{CuCO}_3 + \text{Cu}(\text{OH})_2$, forms monoclinic, frequently twin, crystals which are rarely perfectly developed, simple crystals being seldom found. It also occurs massive with botryoidal or stalactitic surface often fibrous and frequently granular or earthy. Its colour is a bright green, and its specific gravity varies from 3.7 to 4.01. Green malachite accompanies other ores of copper, occurring especially in the Urals, at Chessy in France, and in Cornwall and Cumberland in England. At the copper-mines of Nischne-Tagilsk, belonging to M. Demidoff, a bed of malachite was found which yielded many tons of the mineral. The fibrous varieties are frequently deposited in different coloured layers which take a high polish, and from these masses vases and other ornamental articles are manufactured. It also forms a most valuable copper ore. Crystals of malachite can be obtained artificially by allowing a piece of porous limestone to lie in a solution of copper nitrate having a specific gravity of 1.1, until the stone becomes covered with basic nitrate and then bringing it into a solution of soda crystals having a specific gravity of 1.04, when after a few days malachite crystals are formed (Becquerel). When a solution of copper sulphate is precipitated in the cold with sodium carbonate, a blue precipitate of $\text{CuCO}_3 + \text{Cu}(\text{OH})_2 + \text{H}_2\text{O}$ is thrown down. This on standing is converted into a green powder having the composition of malachite. Verdigris or copper rust formed by the joint action of air and water on copper possesses the same composition as malachite.

Azurite or Azure Copper Ore, $2\text{CuCO}_3 + \text{Cu}(\text{OH})_2$, occurs together with malachite and other copper ores forming shining monoclinic tables or short prisms, and also as an amorphous or earthy mass having a dark azure-blue colour. It possesses a specific gravity of 3.5 to 3.83. If crystallized copper nitrate be heated with pieces of chalk under a pressure of from 3 to 4 atmospheres a crystalline warty mass of azurite is formed (Debray). Azurite dissolves in a hot solution of sodium bicarbonate and the solution on boiling deposits a green powder of malachite.

COPPER AND SULPHUR.

200 Cuprous Sulphide, Cu_2S , occurs in nature as chalcocite, copper-glance, or vitreous copper in rhombic six-sided tables or prisms having a metallic lustre which is often tarnished green or blue and has a blackish lead-grey streak. It has a specific gravity of from 5.5 to 5.8. The same compound is also formed as a black brittle mass when copper is burnt in sulphur vapour, and when large quantities of copper and sulphur are fused together. Mitscherlich in this way succeeded in obtaining this compound in rhombic octohedrons. When finely divided copper obtained by reducing the carbonate in hydrogen is mixed with milk of sulphur in equal atomic proportions and the mixture dried over oil of vitriol and then gently triturated in a mortar the constituents combine as soon as a uniform mixture is obtained forming cuprous sulphide, the combination being attended with such a development of heat that the temperature of the mass is raised to redness.¹

Cupric Sulphide, CuS , occurs in nature as covellite or indigo-copper, occurring sometimes in hexagonal crystals but more frequently in the massive state at Mansfeld, on Vesuvian lavas, and in Chili. It has a semi-metallic lustre, an indigo-blue colour and a specific gravity of 4.6.

This compound is prepared artificially by heating cuprous sulphide with flowers of sulphur to a temperature not above that of boiling sulphur (Hittorf). It also may be prepared by triturating finely-powdered cuprous sulphide in a mortar with cold strong nitric acid until the action ceases; the powder is then washed, cupric sulphide remaining behind.² It may likewise be obtained as a blackish-brown precipitate by passing a current of sulphuretted hydrogen gas into a solution of a cupric salt. The finely-divided moist precipitate easily oxidizes on exposure to the air. When cupric sulphide is heated in absence of air it decomposes into sulphur and cuprous sulphide, and if the ignition be conducted in an atmosphere of coal-gas the cuprous sulphide assumes the crystalline form of chalcocite.

¹ Winkelblech, *Ann. Pharm.* xxi. 34.

² Faraday, *Quart. Journ. Sci.* xxi. 183.

COPPER AND NITROGEN.

201 Nitrogen gas does not act upon red-hot copper. Ammonia gas treated in the same way undergoes decomposition into its elements and the metal temporarily absorbs nitrogen becoming porous or crystalline.

Copper Nitride, Cu_3N_2 , is obtained in the form of a dark green powder by leading a current of ammonia gas over copper oxide heated to 250° . At a higher temperature than this the nitride decomposes into its elements with ignition.

COPPER AND PHOSPHORUS.

202 These elements unite together at a red-heat (Marggraf). When phosphorus is added to molten copper and the fused mass stirred up until it approaches its point of solidification, three distinct layers are formed. The uppermost layer consists of a bright, very hard, brittle mass which contains seven to twelve per cent. of phosphorus; the central layer, containing four to six per cent., is a grey granular mass, whilst the lowest, existing in only small quantity, contains about 0.5 per cent. of phosphorus. By melting these phosphides with copper alloys containing any wished-for percentage of phosphorus may be obtained. These melt at a much lower temperature than pure copper even when the percentage of phosphorus is so low as 0.5. The tenacity of the copper is also considerably increased by the presence of a small quantity of phosphorus, provided the metal be cast in a chill. Percy,² who has examined the subject, has shown that the presence of a small quantity of phosphorus in copper has some effect in protecting the metal from the corrosive action of sea-water.

Cuprous Phosphide, $(\text{Cu}_2)_3\text{P}_3$, is formed when phosphuretted hydrogen is passed over heated cuprous chloride, or when phosphorus vapour is passed gently over ignited metallic copper. According to the temperature at which it is formed this compound is either black, or grey, or forms a silver white mass with metallic lustre. It is very brittle and when obtained at a high temperature it forms a coherent mass capable of taking a polish.

¹ Abel, *Quart. Journ. Chem. Soc.* [2], iii, 249.

² *Brit. Assoc. Reports*, 1849 [2], p. 39.

It is scarcely soluble in hydrochloric acid but dissolves easily in nitric acid.

Cupric Phosphide, Cu_3P_2 , is formed when phosphuretted hydrogen is passed over cupric chloride or by passing the same gas into a solution of copper sulphate as well as when phosphorus is boiled with a cupric salt. Cupric phosphide is a black powder, or, when prepared at a high temperature, a greenish black metallic mass which, when ignited in hydrogen, is converted into cuprous phosphide.

COPPER AND ARSENIC.

203 These elements combine in several proportions, whilst certain copper arsenides are found as minerals; thus whitneyite, $\text{Cu}_{18}\text{As}_2$, occurring as a bluish red or greenish white amorphous or crystalline malleable substance found in Michigan and also in California and Arizona. Algodonite, $\text{Cu}_{12}\text{As}_2$, found in Chili and Lake Superior, possesses a silver-white or steel-grey lustre; and domeykite, Cu_6As_2 , found at Portage Lake, has a tin-white to steel-grey colour. According to Reinsch the grey deposit obtained when metallic copper is placed in a solution of arsenic trioxide in hydrochloric acid has the composition Cu_5As_2 , and this on heating is converted into Cu_6As_2 . When equal parts of arsenic and copper filings are fused together, a white finely granular alloy termed white copper is formed, having the composition Cu_4As . When arseniuretted hydrogen is passed over dry cupric chloride the alloy Cu_3As_2 is formed.

DETECTION AND ESTIMATION OF COPPER.

204 Copper compounds colour the non-luminous gas flame or the point of the blowpipe flame green or blue, especially in the presence of silver chloride. The spectrum of this flame is a banded one containing a large number of lines of which two in the violet lying between the rubidium and caesium lines are the most characteristic. The spark spectrum of cupric chloride is also rich in lines and contains very bright lines in the green (Lecoq de Boisbaudran). When borax is moistened with any copper salt and heated in the oxidizing flame a bead is obtained which, when hot, is green and when cold possesses a blue colour; in the reduction flame, especially with the addition of a small

quantity of tin or tin dichloride, the bead becomes red and opaque with separation of metallic copper. Copper salts are thrown down by sulphuretted hydrogen in the form of a brownish-black precipitate of CuS , which is slightly soluble in ammonium sulphide, but not in freshly prepared potassium or sodium sulphide. The precipitated sulphide dissolves readily in warm dilute nitric acid forming a clear blue solution which assumes a fine dark-blue colour on the addition of ammonia. This reaction is employed for the quantitative separation of copper from all other metals. Copper can also easily be detected by the reduction to the red metallic bead on charcoal before the blowpipe, or upon the charred end of a lucifer match (Bunsen's test).

Copper is determined quantitatively either as oxide or as metal. For the purpose of determining it as oxide, the boiling solution of the copper salt is treated with a slight excess of pure potash or soda, the precipitate repeatedly washed by decantation with boiling water, then thrown on to a filter, again washed, dried, and ignited. When copper is determined in the metallic state the solution must be free from nitric acid; this is attained by evaporating repeatedly with hydrochloric acid or sulphuric acid; the solution is then brought into a platinum basin, a small quantity of zinc added, and enough hydrochloric acid to set up a slow evolution of hydrogen. The copper separates out partly as a solid deposit on the platinum and partly in the form of a spongy mass. When the whole is thrown down and the zinc is all dissolved, the copper sponge is pressed into a coherent form, washed repeatedly by decantation with boiling water, dried in a steam-bath, and weighed together with the tared basin. As pure zinc is not always easy to obtain, cadmium or magnesium may be employed instead. Satisfactory results are also obtained by precipitating the metal by means of a galvanic current. This method is made use of in copper works where a large number of determinations have to be made each day.

The atomic weight of copper was determined by Berzelius by reducing precipitated copper oxide with hydrogen; as a result of two experiments he obtained the number 63.15. By the same method Erdmann and Marchand obtained as a mean of five experiments the number 63.30, and Hampe, working with large quantities and very pure materials, obtained by the reduction of the oxide as well as by the electrolysis of copper sulphate the atomic weight of 63.17.¹

¹ *Zeitsch. Anal. Chem.*, xiji 352, and xvi. 458.

SILVER (ARGENTUM), Ag = 107.66.

205 Silver has been known from earliest times, and the oldest names by which it was designated referred to its bright white colour; thus in the Hebrew *Késeph*, the root of which signifies to be pale, whilst the Greek word *ἀργυρος*, silver, is derived from *ἀργός*, shining. The alchemists termed silver Luna or Diana, and it is often represented by the symbol of the crescent moon.

Silver occurs frequently in the native state, and is sometimes found in considerable quantity; thus, in the museum at Copenhagen is a mass of native silver found at Kongsberg in Norway which weighs a quarter of a ton, and in South Peru masses have been found which weigh more than 8 cwt., whilst at Idaho, at the "poor man's lode" large masses of native silver have also been obtained. Native silver usually contains gold, copper, and sometimes mercury and other metals.

The most important ores of silver are: argentite or silver-glance, Ag_2S ; pyrrargyrite, ruby-silver, or dark-red silver, Ag_3SbS_3 ; stromeyerite or silver-copper glance, $(\text{AgCu})_2\text{S}$; stephanite, Ag_3SbS_4 ; polybasite, $(\text{AgCu})_9(\text{SbAs})_8\text{S}_9$; chlorargyrite or horn-silver, AgCl . Of less importance are proussite or light-red silver ore, Ag_3AsS_3 , dyscrasite, Ag_4Sb , silver bromide, AgBr , silver iodide, AgI , and others. Silver also occurs in sea-water, a fact which was known to Proust in the year 1787.

206 *Metallurgy of Silver*.—Metallic silver is prepared from its ores according to three different processes; either it is alloyed with lead and then the lead removed by oxidation, or it is amalgamated with mercury and this removed by distillation; or lastly, it is brought into solution as a salt and the metal precipitated by means of copper. The practical adoption of one or other of these processes depends upon the nature of the ore, the position of the mine, and the price of labour, fuel, &c.

It was by the first of these methods that the ancients extracted silver from its ores, and this one remained for long the only known process. Strabo describes the method adopted in Spain for this purpose. The washed ore was melted with lead and after this was got rid of (*ἀποχυθέντος τοῦ μολύβδου*) the pure silver remains behind. Pliny also, though he did not understand the nature of the operation, states that in order to obtain

pure silver the ore must be cupelled together with lead; concerning the silver ore he says, "excoqui non potest, nisi cum plumbo nigro aut cum vena plumbi—et eodem opere ignium descendit pars in plumbum, argentum autem innatat, ut oleum aquis," being an indistinct statement of the mode in which metallic silver separates from the oxidized slag. This process was termed by Basil Valentine "Saigern" or "eliquation."

The Cupellation Process.—The principles upon which the process of cupellation depends have been explained under Lead, (see p. 277). The chief object of this process is generally to prepare silver, but in some cases the lead oxide or litharge is the staple article required, and in this case the refining of the silver becomes a secondary consideration. There are many distinct forms of furnace, modes of refining, &c., in use, but only two distinct methods of cupellation are employed, viz.: (1) the English, and (2) the German system.

(1) *The English Process.*—The peculiarity of this system is that the cupel or porous hearth upon which the oxidation takes place is moveable, the lead being added at intervals.

Figs. 101 to 105 inclusive, show the construction of the most modern form of English cupellation furnace or refinery. Fig. 101 shows the side-elevation; Fig. 102, the plan; Fig. 103, a transverse section in the line A B; Fig. 104, a transverse section in the line C D and Fig. 105, the plan of the test and test frame.

The refinery consists essentially of a reverberatory furnace. The metal to be refined is placed upon the hearth, or cupel, or test (E). This consists of an oval wrought-iron frame (A A' Fig. 105) about five feet long and two-and-a-half feet wide, which is crossed by five iron bars (a). This frame is filled with finely-powdered bone-ashes, moistened with a little water in which a small quantity of potassium carbonate has been dissolved. This is well solidified by heating, and is scooped out until it is about an inch thick and has the form shown in the figure. A flat rim of bone-ash is thus left all round, about two inches wide, except at one end (E), called the front or breast of the cupel where it is five inches wide, and through this a channel (G) connecting the bed of the cupel with the slot (G') is cut to allow the melted oxide of lead to flow out into the wagon (I), beneath, without coming in contact with the iron which it would corrode. The cupel thus arranged is wedged up into its place in the furnace, of which it forms the hearth (E), where it is so arranged that the flame from a coal fire lying on the bars plays over its surface, the door of

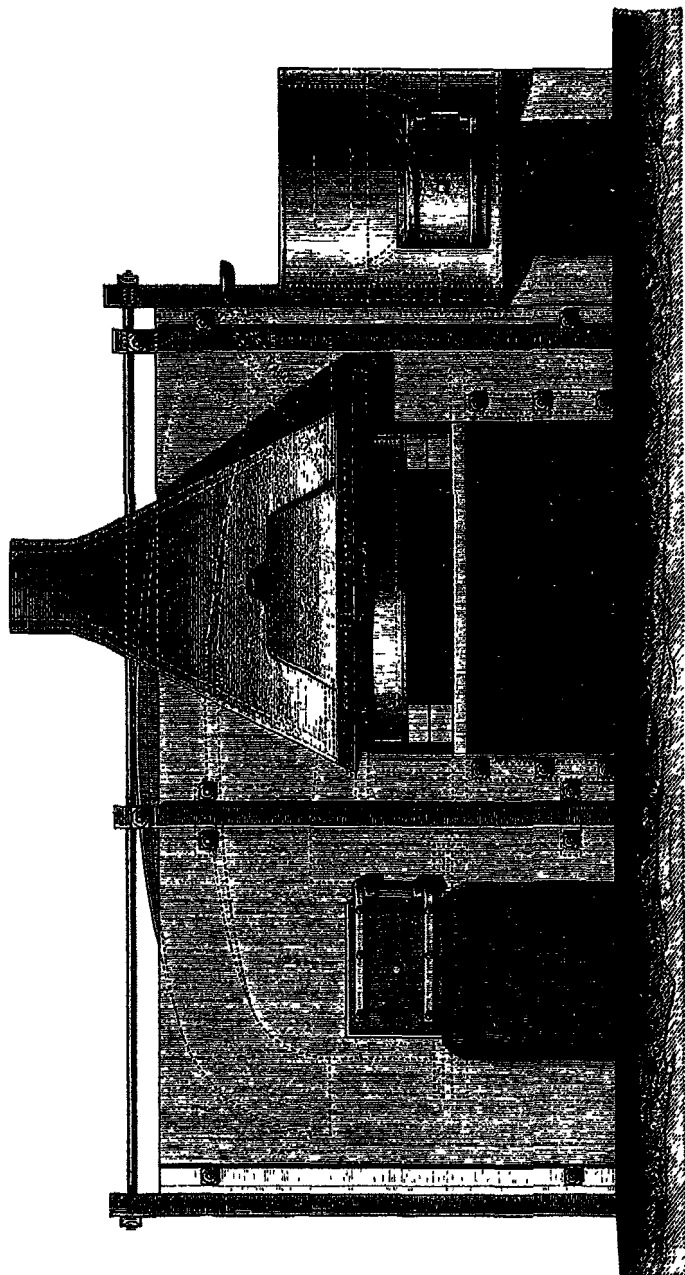

FIG. 101.

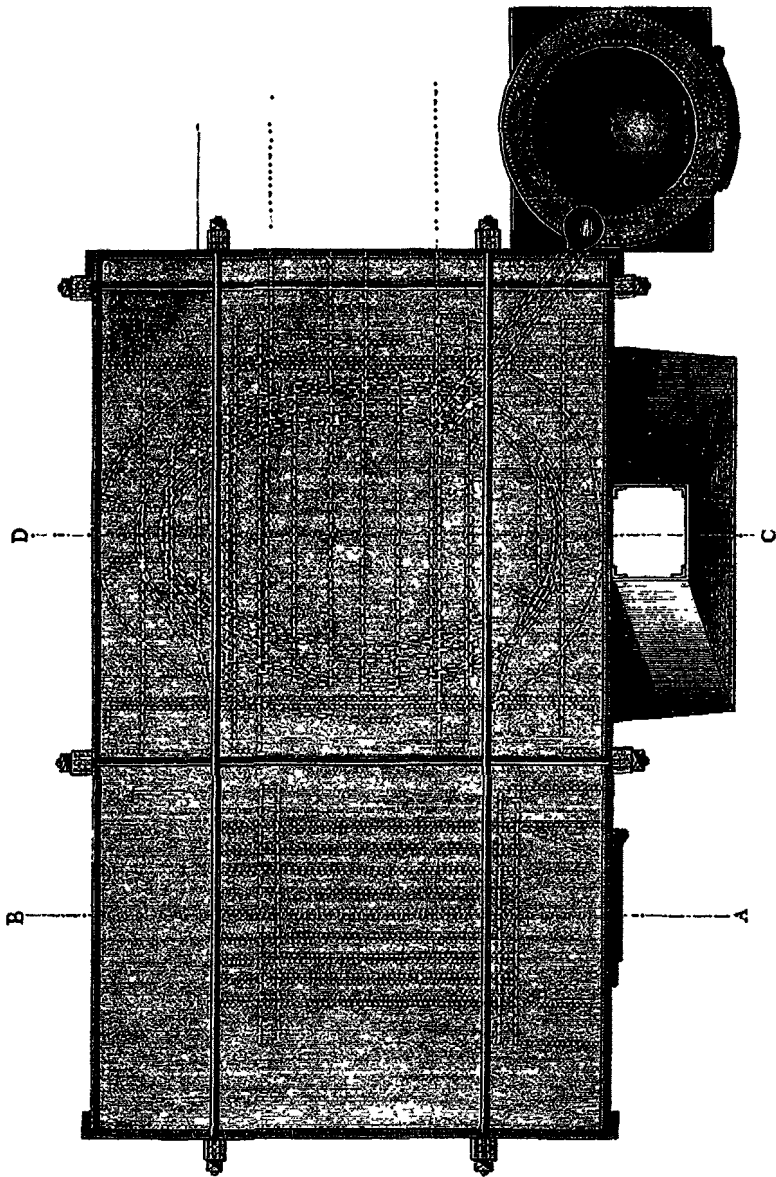

FIG. 102.

the furnace being shown in Fig. 101, and the products of combustion escaping through the two flues (L and L' Fig. 103). A blast of air from the nozzle or tuyere (M Fig. 103), enters the cupel at the side opposite that against which the breast of

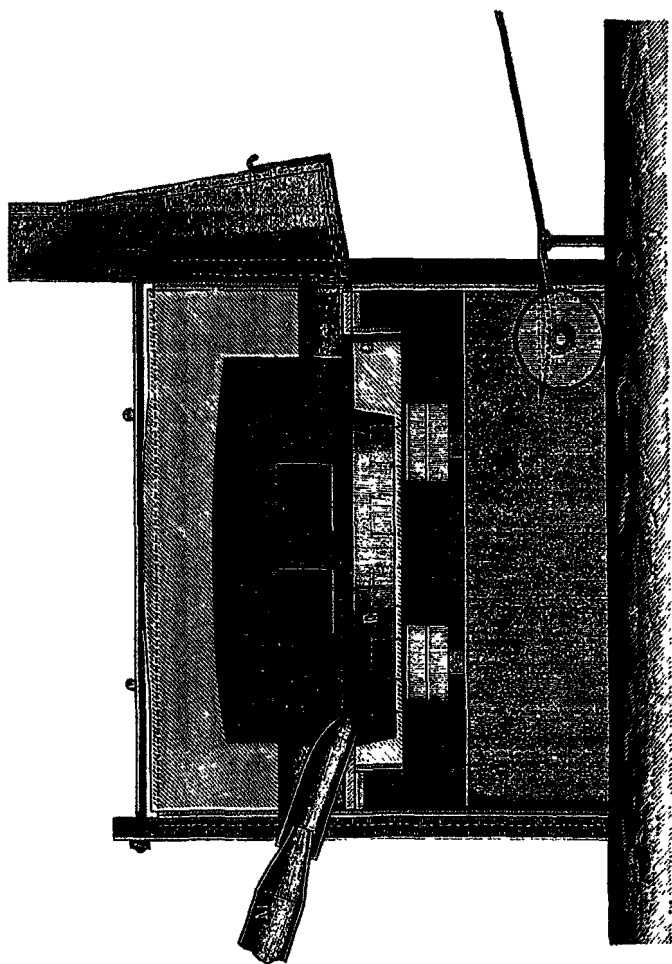

FIG. 103.

the cupel is placed, a current of air being thus blown over the surface of the lead at the rate of about 200 cubic feet per minute. Opposite the door is a hood (N) for carrying the fumes into the chimney. The temperature of the cupel is

gradually raised to redness, and almost filled with the lead to be heated, which is ladled in from the iron pot where it has been previously melted by means of a fire placed beneath. Fresh lead is added from time to time to supply the place of that which is oxidized, until at length a quantity of lead originally amounting to about five tons is reduced to between two and three cwt. This melted metal is withdrawn

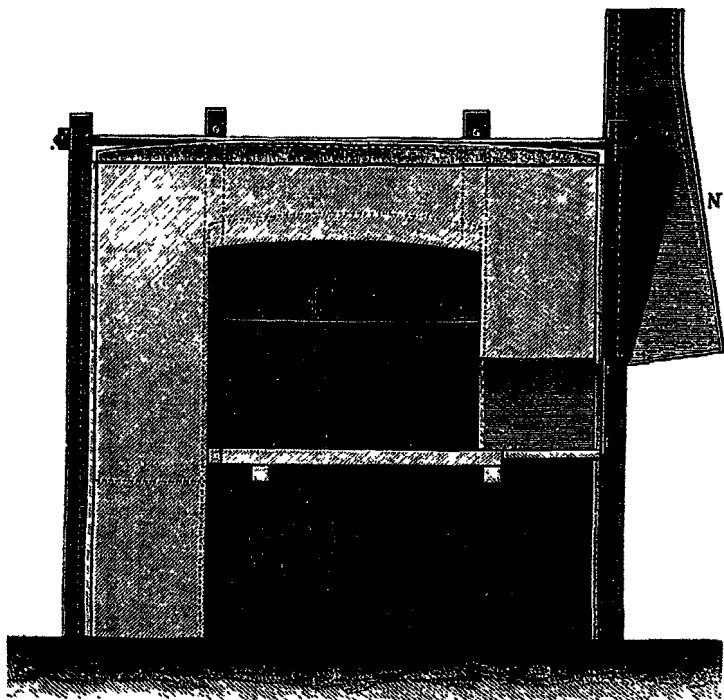

FIG. 104.

by making a hole through the bottom of the cupel; the aperture is afterwards closed with fresh bone-ash, and another charge is proceeded with. When a quantity of rich lead sufficient to yield from 3,000 to 5,000 ounces of silver, or from 93 to 155 kilos., has been thus obtained, it is again placed in a cupel, and the last portions of lead are removed. It is found advantageous to effect this final purification of the concentrated silver-lead separately, because in the last stages of the operation the litharge carries a good deal of silver down with it; these

portions of litharge, therefore, on being reduced, are again subjected to the desilverizing process.

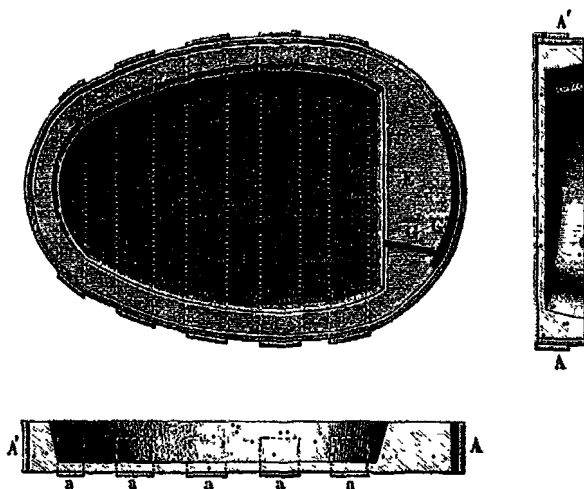

FIG. 105.

(2) *The German Cupellation Process.* This differs from the English inasmuch as the hearth is formed of clay instead of bone ash. It is made of large dimensions, and the whole of the charge is placed on the cupel at once. The furnace used for this purpose is shown in Fig. 107. The circular cover *k*, is movable for the purpose of renewing the cupel. When all is ready, straw is thrown upon the hearth, on to which the pigs of rich lead are placed; the cover *k* is then lowered and the joints made good with clay; the fire is lighted, and as soon as the lead is melted its surface becomes covered with a dark crust termed "abzug," consisting of the oxides of foreign oxidizable metals and other impurities in the lead; this crust is skimmed off through the working door (*G*); the heat is then kept so as to maintain the lead at a dark-red heat, whilst the impurities cease to separate in the form of the scum. The next product which appears is known as "abstich," or impure litharge, and at the end of two hours the formation of the pure litharge begins, the temperature being kept up at a cherry red heat until the operation is complete. Just before the last portions of lead are removed a beautiful appearance, known as the fulguration of the metal,

is noticed. During the early stages of the operation the film of lead oxide is constantly being formed, and this is renewed as rapidly as it is removed; but when the lead has all been oxidized, the film of litharge becomes thinner and thinner, and as it flows off a succession of beautiful iridescent tints due to the colour of thin films (Newton's rings) are observed, and after a few moments the film of oxide suddenly disappears and the brilliant surface of the metallic silver is seen beneath.

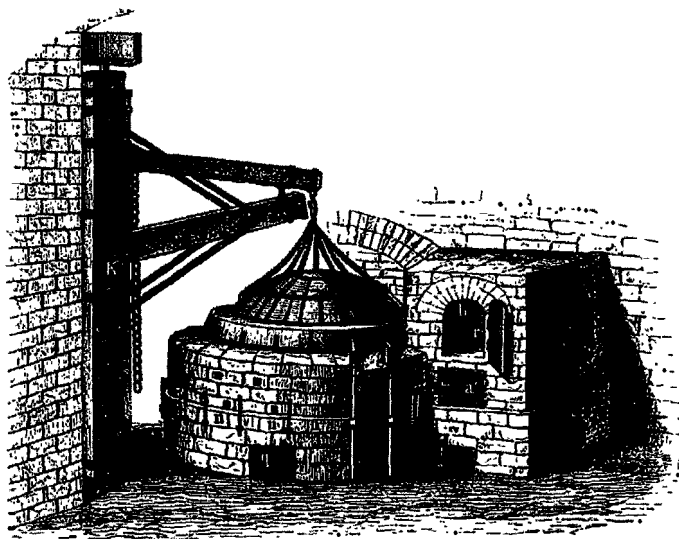

FIG. 106.

It has already been observed under lead that the cupellation process can only be economically worked when the lead contains more than one-tenth of a per cent. of silver. If the ore contains less silver than this the silver must be concentrated either by Pattinson's process or by melting with zinc. In the latter process the product is either worked up by cupellation or the silver is separated from the zinc by heating the alloy in a current of steam and the oxide of zinc washed away from the metallic silver.

207 *The Mexican Amalgamation Process.* Although the ancients were well acquainted with the power possessed by mercury to dissolve gold and silver, it does not appear that they

applied this knowledge to the extraction of silver from its ores. This was first done in Mexico in the year 1557 by Bartholomeo de Medina, and applied on the large scale in the year 1566. The same process was employed at Potosi in Peru in 1574, and fully described in 1590 by Joseph Acosta, in his *Historia natural y moral de las Indias*. The identical method is still carried on in Mexico, Peru, and Southern Chili, and is valuable for these localities where cheap fuel cannot be obtained. The ores which are worked by this process contain metallic silver, sulphide of silver, chloride of silver, &c., these substances being distributed in small masses through large quantities of gangue, thus rendering it difficult or impossible to separate the ore by washing.

The first operation in the process, which has to be carried on in a country devoid of fuel and running water, and where, therefore, neither steam- nor water-power can be obtained, is the fine division of the ore. This is effected by stamping- and grinding-mills worked by horse- or mule-power, and termed *arrastra*. Into these water and ore are brought and ground together to a fine mud between blocks of porphyry fastened to an axis which is turned by the mules; the wet and powdered ore is then brought on to a paved floor termed a *patio*, and mixed with from 3 to 5 per cent. of common salt, and the salt thoroughly incorporated with the mass by the treading of mules. After standing for a day, mercury is added together with a substance termed *magistral*, an impure mixture of cupric and ferric salts. As soon as the *magistral* has been added, more mercury is poured on, and the heap or *torta* is again trodden by mules to bring about a thorough incorporation of the ingredients and thus to effect the chemical decomposition which their contact entails. The treading of the *torta* is generally performed by mules which are blindfolded and tied together four abreast; one mule for every two montones (about three tons) is required at Guanajuato for the effectual treading of a heap. A driver, who stands in the centre of the *torta*, guides the animals with a long halter, causing them first to tread at the outer edge, and gradually diminishing the radius of the circle described. The time necessary for working a *torta* varies from fifteen to forty-five days according to circumstances (Phillips).

As soon as the amalgamation is found to be complete, the slimy mass is washed in buddles worked by mules, the lighter particles of mud washed away and the heavier amalgam

deposited. The amalgam is next filtered through canvas bags to remove mechanical impurities, and then distilled by being placed under a large iron bell luted at the bottom with water, round the upper part of which a charcoal fire is lighted. The silver which is then left behind, and termed *plata piña*, possesses a white frosted appearance and is fused into bars in the usual way.

The chemical reactions which occur in the process have been investigated by Boussigault, Karsten, and other chemists, but in spite of their investigations there still remains some degree of doubt respecting the exact nature of the reaction.

The following is the probable explanation of the chemical changes which occur. The first reaction is a double decomposition between the sulphates of iron and copper and chloride of sodium with formation of the chlorides of the metals. These decompose silver sulphide into silver chloride :



The cuprous chloride then formed dissolves in common salt and acts further upon the sulphide :

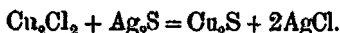

The solution of the silver chloride in common salt is then decomposed by the metallic mercury with formation of calomel and metallic silver. All the mercury which is thus converted into calomel is lost, and it amounts to about double the weight of the silver obtained.

The European Amalgamation Process was introduced about the year 1780, when v. Born established an amalgamation works at Schemnitz in Hungary, whence it was introduced at a later date to Freiberg and Mansfeld. This process, which is now no longer worked, consisted in roasting the sulphurous ores with common salt, in order to convert the silver sulphide into chloride; the roasted and powdered mass was then brought together with water, scrap iron, and mercury, into barrels which were caused to rotate on a horizontal axis; in this way silver chloride was decomposed and the metallic silver thus formed dissolved out by mercury.

The American or Washoe Amalgamation Process. Owing to the scarcity of fuel and labour in the Nevada districts, where large quantities of both rich and poor silver ores occur, it was found impossible to work the ordinary methods, because the

preliminary roasting of the ore necessary in the barrel process cannot be carried on, and the loss of mercury in the Mexican process is too great to render that method applicable to the large quantity of poor ore which the district yields.

This necessity led to the invention of a process of amalgamation in iron pans, and is called, from the name of the district, the Washoe Process. The richer ores of the Nevada mines contain many other metals, and are usually roasted with common salt in reverberatory furnaces and then amalgamated in barrels. The poor ore, on the other hand, after having been stamped to powder is then ground in cast-iron pans together with mercury and hot water, with or without the addition of common salt and copper sulphate. The amalgam is next washed, strained in bags, and distilled in carefully-constructed cast-iron retorts, and the silver which remains melted and cast into ingots. The chemical changes which occur in this process of amalgamation are similar to those taking place in the Mexican operation, but as the ore contains a considerable proportion of native silver, the presence of a copper salt is not so necessary, as under the influence of heat and friction mercury and iron alone are capable of extracting the silver. The loss of mercury in the Washoe method is much less than in the older amalgamation operations, as it is chiefly mechanical, no mercury salt being formed.

Another improvement is the addition of from 1 to 2 per cent. of sodium to the mercury whilst the amalgamation is going on. This depends upon the fact that pure mercury becomes covered with a coating of mercury sulphide which divides the metal into fine globules or makes it "mealy"; the addition of sodium prevents this, as the alkali-metal decomposes the sulphide of mercury with formation of sulphide of sodium and enables the mercury to flow together into a coherent liquid mass.

208 *Extraction of Silver in the Wet Way.* Several of these processes have now come into general adoption in Europe. Ziervogel's process, now carried on in Saxony, depends upon the fact that when copper argentiferous pyrites is roasted the copper and iron sulphides are converted into insoluble oxides, whilst the silver is converted into a soluble sulphate which is dissolved out by lixiviating the roasted ore with hot water, the silver being readily precipitated from this solution in the metallic state.

Percy-Patera Process. Another wet process in use at Joachimsthal depends upon the following reactions, first suggested

by Percy, and afterwards carried out by von Paterna. The argentiferous ore is first roasted with common salt, by which the silver is converted into the chloride; this is then dissolved out by a cold dilute solution of sodium thiosulphate, the silver in solution being precipitated as sulphide by sulphide of sodium, and lastly the sulphide of silver is reduced to metal by exposure to a high temperature in a muffle furnace.

Claudet's Process. The burnt pyrites of the sulphuric acid makers not only contains, as we have seen, copper, but also small quantities of silver, which occurs in the cupreous liquors in the form of chloride dissolved in the excess of common salt. Although the quantity of silver in the burnt ore does not often exceed 12 dwts. to the ton, it is found possible to obtain this economically in the form of insoluble silver iodide by adding a solution of kelp to the tank liquor, a small trace of gold being at the same time precipitated. The results obtained at the Widnes metal-works by this process show that 0.65 oz. of silver and 3 grains of gold may be extracted from each ton of ordinary Spanish pyrites, at a total cost, including labour, loss of iodine, &c., of eightpence per ton, or 12.3 pence per ounce of silver produced. If from this amount be deducted the value of the gold, the expense of working a ton of ore is reduced to twopence; thus leaving a profit of about three shillings on each ton of ore worked (Phillips).

209 *Preparation of Pure Silver.* The purest silver which occurs in commerce contains traces of other metals. Stas' classical researches on atomic weight determinations have shown how difficult it is to obtain any substance chemically pure, and this fact is especially well illustrated in the case of the purification of silver, a metal which possesses such characteristic reactions that one would suppose its separation in a state of chemical purity to be an easy task, and yet this is far from being the case. The best method for obtaining pure silver is to dissolve ordinary silver in pure nitric acid, when a certain quantity of gold remains undissolved. The solution is then evaporated, and the residue fused in order to decompose any platinum nitrate that may be present. The residue is next dissolved in dilute ammonia, and the filtered blue liquid diluted with enough water to bring the strength down to 2 per cent. of silver. A sufficient quantity of normal ammonium sulphite is now added to render the solution colourless on warming, and the liquid is allowed to stand in closed stoppered vessels for

twenty-four hours, when a third of the silver separates out in the crystalline form. The liquid, which is still blue when cold, is poured off and heated from 60° to 70°, when the remainder of the silver is deposited. In order to remove every trace of copper, the metallic precipitate is washed with water and allowed to stand for several days in contact with strong ammonia; it is then again washed and dried and fused in an unglazed porcelain crucible with 5 per cent. of fused borax and 5 per cent. of sodium nitrate, and lastly it is cast in moulds which have been lined with a mixture of burnt and unburnt porcelain clay. The bars must then be cleaned with sand and heated with potash to remove every trace of adherent silicate, and finally washed with water.

Stas also prepared the pure metal from the commercial fine silver as follows. It is first dissolved in dilute nitric acid; the evaporated residue fused as long as red fumes are evolved. The mass is then dissolved in water, filtered and diluted with thirty parts of filtered rain-water to one of silver, and then the silver chloride thrown down with pure hydrochloric acid, and the precipitate washed first with dilute hydrochloric acid and then with pure water. The precipitate is next dried and the powder well rubbed up in a mortar. This is then repeatedly digested with aqua-regia and afterwards well washed, and the silver chloride reduced to metal by boiling with dilute chemically pure caustic potash to which milk sugar is added. The reduced silver is washed with dilute sulphuric acid and water, dried and fused.

Pure silver is used in the laboratory for volumetric analysis. It is not necessary for this purpose to have it so pure as the metal employed by Stas for his atomic weight determinations, and it may be obtained sufficiently so by boiling the well-washed silver chloride with caustic potash and sugar. The point of complete reduction is ascertained by taking a small portion out, washing it well with water, and dissolving in pure dilute nitric acid; if the reduction be complete it will dissolve without residue. The metal is then melted in a crucible together with some pure sodium carbonate.

210 Properties. Silver possesses a pure white colour, and takes a high polish. Of all the metals it is the best conductor of heat and electricity, and is very tough and malleable, since 0.1 gram can be drawn out into a wire 180 m. in length and silver leaf can be beaten out to a thickness of 0.00025 mm. In

the finely divided state, as obtained by the reduction of the chloride and other salts, silver presents the appearance of a dull dark grey powder. *Molecular silver*, employed in organic chemistry, is obtained, according to Wislicenus,¹ by bringing zinc into contact with finely-divided silver chloride which has been precipitated in the cold and washed until nearly free from acid. In a few hours the chloride is completely reduced and the precipitated silver may be separated from the sheet zinc by washing, and then treated with dilute hydrochloric acid to remove every trace of zinc. It is then brought on to paper and dried in the air and afterwards gently heated to 150°. Thus prepared it is a grey powder, possessing no metallic lustre, which, however, it assumes when rubbed under a burnisher or heated to redness. Silver is precipitated in very thin films in the form of a lustrous metallic mirror-like deposit on glass from ammoniacal solution in presence of many reducing agents, especially organic substances; it then adheres to the glass and transmits blue light.

Metallic silver occurs native in regular octohedrons which frequently occur maced; dendritic forms also frequently occur. It has also been frequently found in the crystalline form in silver melting furnaces.

Silver fuses at a temperature of about 1040° (Becquerel). In the liquid state it possesses the power of absorbing oxygen from the air, which it gives up on solidification. When a mass of the metal is rapidly cooled the silver solidifies before the oxygen has escaped from the interior; this gas then bursts through the crusts, drives out part of the fused silver in globular masses and excrescences; this peculiar phenomenon is well known as the "spitting" of silver. When charcoal powder is thrown on the surface of the metal the charcoal withdraws the absorbed oxygen, and consequently prevents silver from spitting. The same preventative effect is noticed when silver is fused under common salt, but when fused under nitre the spitting takes place. The presence of 5 per cent. of copper deprives silver of the power of absorbing oxygen.

Silver begins to volatilize at a white-heat, and when heated in a lime-crucible by means of the oxyhydrogen blowpipe it may be readily made to boil. By this process Stas was able to distil fifty grams of pure silver in from ten to fifteen minutes; no residue whatever was left behind, and a portion of the vapour, which has a bright blue colour, was carried out by the current

¹ *Ann. Chem. Pharm.* cxlix. 220.

of oxygen gas, and rendered the air of the laboratory hazy, imparting to it a metallic taste. Distilled silver has a specific gravity of 10.575 (Christomanos); fused silver has a specific gravity of from 10.424 to 10.511 (Holzmann); whilst silver which has been exposed to pressure under the coining press has a specific gravity of 10.57 (G. Rosa.)

Pure silver is used in the laboratory in volumetric analysis and also in the preparation of chemical utensils, as this metal is not, like glass or platinum, attacked by fused caustic alkali.

SILVERING AND PLATING.

211 Objects made of copper or of brass, bronze, German silver, or similar alloy are frequently silvered to give a bright and permanent surface to these metals. If the covering of silver be thick the goods are said to be plated; if thin, they are said to be silvered. Silvering may be effected either by a dry or by a wet process. Dry silvering is effected by rubbing silver amalgam on the surface of the metal, which has previously been cleaned by acids or by agitating the articles with this amalgam. On heating, the mercury is expelled and a very thin film of silver left behind, which, on burnishing, gives a bright silvery surface.

Instead of the amalgam, a mixture of four parts of precipitated silver, sixteen parts of sal-ammoniac, sixteen parts of common salt, and one part of corrosive sublimate is employed, mixed together with water to form a paste. Wet silvering is especially employed for the silvering of thermometer and barometer scales, divided circles, and the like. One process is simply to clean the surface of brass or copper by momentary immersion in nitric acid, and then, after washing it with water, to cover it with a mixture of equal parts of silver chloride and cream of tartar, or equal parts of chloride of silver, common salt, and whiting. The mixture is rubbed in until a sufficient deposit has been obtained. A second process is employed for silvering small articles such as pins, buttons, &c. : for this purpose a solution of silver chloride in sodium sulphite or thiosulphate or in common salt, or cream of tartar, is employed; a warm solution is used, and the silver is instantly deposited upon the metallic object.

The plating of copper is effected by polishing the surface of the ingot which is to be plated, and then placing upon it a strip of bright silver, the area of which is somewhat smaller than that of the copper; the compound ingot is then exposed to a

temperature slightly below the fusing point of silver, and by hammering or rolling at this temperature the two metals are sweated together, as it is termed; no soldering is employed in this process; the ingot is then rolled until it is reduced to the required thickness.

Electro-deposition of silver. The process of electro-plating in silver was discovered by Messrs. Wright and Parkes of Birmingham in the year 1840. They were employed during that year in making experiments with a view of obtaining a bright and firm deposit of metallic silver by an electro-process similar to that by which Jacobi, Jordan, and Spencer had succeeded in obtaining the deposition of copper. Their attempts however were not completely successful, inasmuch as they either obtained only a very thin coherent film, or else the whole of the silver was thrown down in the form of a grey powder. At this juncture Mr. Wright met with a passage in Scheele's *Chemical Essays*, (pp. 404-6), which soon proved of the highest importance to the commercial success of his undertaking, by enabling him to obtain suitable deposits of silver and gold. Speaking of the solubility of the oxides and cyanides of gold, silver, and copper, Scheele says, "that if these calces (that is the cyanides of gold and silver) have been precipitated, and a sufficient quantity of the precipitating liquor be added in order to redissolve them, the solution remains clear in the open air, and in this state the aerial acid (that is, the carbonic acid of the air) does not precipitate the metallic calx."¹ Working with this idea, Wright first employed a solution of chloride of silver in potassium ferrocyanide and quickly got a thick deposit of firm and white silver, a result which had never previously been obtained. Soon after that he found that the solution of silver cyanide in cyanide of potassium gave still better results; and, submitting his results to the well-known firm of G. R. and H. Elkington, a patent was taken out, and this patent process proved to be the foundation of all electro-plating of gold and silver because it included the solutions of the alkaline cyanides, the only liquids which fulfil all the necessary conditions. The silver-plating solution consists of a solution of cyanide of silver in cyanide of potassium, an excess of the cyanide of potassium being added in order that no cyanide of silver shall separate out on the positive pole, which always consists of silver. The battery wires are of copper covered with gutta-percha, the ends only remaining

¹ Gore, *Electro-Metallurgy*, p. 19.

free. The action which takes place in this electrolysis is the same as that described under copper electro-plating. The negative pole is connected with the object to be silvered, and upon this the silver is separated, whilst at the positive pole cyanogen is formed; this combines with the silver which forms the pole, and the cyanide of silver thus formed dissolves in the excess of potassium cyanide.¹

212 Silvering of glass and mirrors. Many organic bodies possess the power of precipitating silver in the form of a highly coherent mirror when brought into contact with an alkaline silver solution; this mirror deposits in the form of a brilliant adhering mirror-like coating. Of the many methods which have been proposed for silvering on glass the first was one suggested by Liebig.²

In this process a *silvering liquid* (A) and a *reducing liquid* (B) are required.

In the preparation of the *silvering liquid* (A) the following solutions are employed:

(1) A silver solution prepared by dissolving one part of fused nitrate of silver in ten parts of distilled water.

(2) An ammonia solution prepared either by neutralizing pure nitric acid with carbonate of ammonia and diluting it until the liquid has a specific gravity of 1.115, or by dissolving 242 grams of sulphate of ammonia and diluting to 1200 cc.

(3) A soda solution prepared from materials free from chlorine and having a specific gravity of 1.050.

The *silvering liquid* (A) consists of 140 volumes of the silver solution, 100 volumes of the ammonia solution, and 750 of the soda solution. If sulphate of ammonia be employed this must be poured into the silver solution and then the caustic soda added in small portions at a time; the liquid is allowed to remain at rest until it becomes clear and then drawn off with a syphon.

The *reducing liquid* (B) is made as follows:—

(1.) 50 grms. of white sugar candy are made into a thin syrup with water, and boiled for an hour with 3.1 grms. of tartaric acid; this solution is then diluted with water to 500 cc.

(2.) 2.857 grms. of dry tartrate of copper are moistened with water and caustic soda solution is added drop by drop until the blue powder is completely dissolved, and the solution is then diluted to 500 cc.

¹ Further particulars respecting this interesting process can be obtained in Gore's *Electro-Metallurgy*.

² *Ann. Chem. Pharm. Suppl.* v. 257.

Thus the reducing solution (*B*) consists of one volume of the sugar solution, one volume of the copper solution, and eight volumes of water.

The glasses to be silvered are placed vertically one over the other; fifty parts of the silvering liquid (*A*), poured in and diluted with 250 to 300 volumes of water, and then ten parts of the reducing liquid (*B*) added. In winter warm water is employed, the temperature of the liquid being 20° to 28°. Optical glasses, especially specula of reflecting telescopes, silvered by this process, are largely employed. They must be placed in a horizontal position, so that they are only just covered by the liquid, and the surface of the silver must permit blue light to pass through it, be brightly lustrous, and so firmly attached that it is not removed by polishing. It is a singular fact that if too much copper be added no silver is deposited at all.

In another very good method of silvering glass, the following solutions are required:

For the first solution 10 grms. of silver nitrate are dissolved in 80 cc. of water, and this poured into a rapidly boiling solution of 8 grms. of Rochelle salt (potassium sodium tartrate), and the solution filtered on cooling. The second solution consists of 10 grms. of silver nitrate dissolved in 80 cc. of water; to this ammonia is added until the precipitated oxide is nearly re-dissolved, and the whole is diluted to 960 cc. The silvering liquid consists of equal volumes of the two solutions.

The following are the directions given by Mr. John Browning for Silvering Glass Specula.

Prepare three standard solutions:—

Solution A	{ Crystals of Nitrate of Silver, 90 grains.
	{ Distilled Water 4 ounces.
Solution B	{ Potassa, pure by Alcohol . . . 1 ounce.
	{ Distilled Water 25 ounces.
Solution C	{ Milk-Sugar (in powder) . . . ½ ounce.
	{ Distilled Water 5 ounces.

Solutions A and B will keep, in stoppered bottles, for any length of time; solution C must be fresh.

“To prepare sufficient of the silvering fluid for silvering an 8-inch speculum proceed as follows:—Pour 2 ounces of Solution A into a glass vessel capable of holding 35 fluid ounces. Add drop by drop, stirring all the time (with a

glass rod), as much liquid ammonia as is just necessary to obtain a clear solution of the grey precipitate first thrown down. Add four ounces of Solution B. The brown-black precipitate formed must be just re-dissolved by the addition of more ammonia, as before. Add distilled water until the bulk reaches 15 ounces, and add, drop by drop, some of solution A, until a grey precipitate, which does not re-dissolve after stirring for three minutes, is obtained, then add 15 ounces more of distilled water. Set this solution aside to settle. Do not filter. When all is ready for immersing the mirror, add to the Silvering Solution 2 ounces of Solution C, and stir gently and thoroughly."

In all processes of silvering glass it is absolutely necessary that the surface of the glass shall be completely clean, and in order that the silver coating may be permanent, it is usual either to varnish it or cover it with an electro-deposit of copper. This however, must not be done in the case of glass used for specula, as the reflecting surface must in this case be of silver.

ALLOYS OF SILVER.

213 The presence of small quantities of other metals, such as antimony, arsenic, bismuth, tin, or zinc, as also that of a small quantity of silver sulphide, renders silver brittle and liable to crack when rolled. The alloys of silver and copper are the only ones which are largely used in the arts. Almost all commercial silver is alloyed with copper, as pure silver is too soft for ordinary purposes as coining and jewellery work. The addition of a small quantity of copper imparts to it a sufficient degree of hardness, and makes it tougher as well as more easily fusible. Thus for instance a wire of pure silver having an area of 1 sq. cm. breaks with a weight of about 2,800 kilos, whereas if it be alloyed with 25 per cent. of copper and drawn cold, it will sustain a weight of from 6,000 to 9,000 kilos.; after ignition it becomes soft, and breaks with a weight of from 3,800 to 4,800 kilos. It has been found that alloys of copper and silver, however perfectly the metals may be mixed and melted together, undergo on solidification a process of liquation, the upper and the lower portions of the ingot differing in fineness from 0.002 to 0.015. Levol has shown,¹ that the only alloy of these

¹ *Ann. Chim. Phys.* [3], xxvi. 220.

metals which does not exhibit this peculiarity is one having the specific gravity 9.9045, and the composition Ag_6Cu_4 . If the fineness be less than corresponds to this formula, the superficial portion is richer in silver; when the percentage of silver is greater than this the interior portions are richest. The fineness of silver alloy is generally calculated upon a thousand parts; thus, for instance, the one above mentioned will have a fineness of 750. The colour of the silver-copper alloys becomes more and more red as the percentage of copper is increased, but an alloy of 1 part of silver and 4 of copper does not possess the true copper colour.

Silver Coin. The proportion of copper in the standard silver used in different countries varies considerably. The English standard coinage silver contains 7.5 per cent. of copper, or has a fineness of 925; the specific gravity of the English silver is 10.30. In France three standard alloys are employed; one containing 950 per mille of silver for medals and plate; another containing 900 per mille for coin; and a third containing 800 per mille for jewellery work. In Germany and Austria the standard for coin contains 900 per mille of silver. The German alloy used for silver-plating contains from 700 to 810 per mille of silver.

The present composition of British silver coin is the same as that issued in the time of Edward I., the alloy in this reign containing 925 of fine silver, and being described as "the old standard of England."

Up to the year 1851 the manufacture of coin was intrusted to a private company termed the moneyers, who had to produce coin varying within very narrow limits, the alloy thus produced being compared with plate of standard silver termed "standard trial plates."

Since the above year the business of coining has devolved upon the government, the Chancellor of the Exchequer being Master of the Mint. The ancient ceremony of the "trial of the pyx" is however still carried on every year. This consists in a public trial by competent assayers appointed by the freemen of the Goldsmiths' Company of the coin (both gold and silver) issued during the year. By this means the accuracy of the coin both as to fineness and as to weight is ascertained, and this trial served in former days as the only safeguard against debasement of the coinage. The fineness of the coins is ascertained at the trial of the pyx by reference to the trial plates whose composition has been determined with the greatest accuracy.

The following table gives the accurate composition of trial plates of various dates, portions of which have been preserved and recently analysed¹ in the Royal Mint. The plates made in former times, when no accurate means of analysis existed, show considerable variation in the composition of the silver standard plates, the standard prescribed by law being in each case the same, viz., 925:—

Date.	Fineness.
1477	923·5
1560	930·2
1660	924·2
1728	928·9
1829	925·0
1873	924·96

Silver is soldered by an alloy containing 6 parts of brass, 5 of silver, and 2 of zinc.

SILVER AND OXYGEN.

214 Silver forms three oxides:—

Silver tetrantoxide or argentous oxide, Ag_4O .

Silver hemioxide or silver oxide, Ag_2O .

Silver peroxide or dioxide, Ag_2O_2 .

Silver Tetrantoxide, or *Argentous Oxide*, Ag_4O , is obtained by the action of hydrogen on different silver salts. The best method of preparation is that given by Wöhler,² and consists in heating silver citrate in a current of hydrogen to a temperature of 100° , when it becomes bronze-coloured, yielding a dark-red solution, from which potash precipitates the black argentous oxide. This, when dried and exposed to pressure, exhibits a dark metallic lustre. On heating it decomposes into the metal and oxygen. Oxyacids decompose it into silver and silver oxide, and when acted upon by hydrochloric acid it yields a brown powder.

Silver Hemioxide, or *Argentous Oxide*, Ag_2O . This is the best defined oxide of silver, and is usually simply called oxide of silver or argentous oxide. It is obtained by precipitating silver nitrate with pure potash or soda. Thus prepared it forms a

¹ W. C. Roberts, *Chem. Soc. Journ.* 1874, 197.

² *Ann. Chem. Pharm.* xxx. i.

brown precipitate, which, when dried at a temperature of from 60 to 80°, becomes almost black. When freshly precipitated silver chloride is boiled with an excess of caustic potash, the same oxide is obtained in the form of a finely-divided bluish-black powder. It is soluble in about 3,000 parts of water, imparting to the solution a metallic taste and an alkaline reaction. In the moist condition it absorbs carbon dioxide from the air: it decomposes soluble chlorides with formation of silver chloride, and precipitates the corresponding oxide from solutions of many metallic salts. When heated to 250° it begins to decompose and loses the whole of its oxygen at 300°, whilst in the presence of hydrogen it is reduced to metal at 100°. When rubbed in a mortar with antimony sulphide, arsenic sulphide, milk of sulphur, amorphous phosphorus, tannic acid, or other easily oxidisable substances, ignition takes place.

Ammonio-Silver Oxide, or Berthollet's Fulminating Silver.

This compound was first obtained by the above-named chemist in 1788, by treating silver oxide which had been precipitated by lime-water with very strong ammonia. It is a black powder, which in the dry state explodes most violently on the slightest percussion, or even when touched with a feather. When oxide of silver is dissolved in warm ammonia this compound, whose composition has not yet been ascertained, is obtained in black crystals having a metallic lustre. These decompose violently with detonation when the liquid is shaken.

Silver Dioxide or Silver Peroxide, Ag₂O₂. The substance, discovered by Ritter in 1814, separates out on the positive pole, in the form of a black crystalline powder consisting of small octohedrons, when a galvanic current is passed from platinum electrodes through a solution of 1 part of silver nitrate in 8 parts of water. It may also be obtained as an amorphous crust by using a silver plate as the positive pole, and allowing the current of electricity to pass through dilute sulphuric acid (Wöhler). It is likewise produced by the action of ozone on silver and silver oxide. When heated it easily decomposes into oxygen and the metal. Hydrogen reduces it at a low temperature with a slight explosion. If brought in contact with sulphur or phosphorus it deflagrates on being struck, and it dissolves in aqueous ammonia with evolution of nitrogen:—

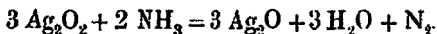

It dissolves in concentrated sulphuric acid, imparting to the liquid a dark-green colour. The solution, which smells of ozone, is tolerably permanent, but when diluted with water oxygen is evolved and silver sulphate is formed. Nitric acid dissolves it with a brownish-red colour, and on diluting this solution with water the peroxide separates out, and soon dissolves with evolution of oxygen.

SALTS OF SILVER.

215 The soluble silver salts have an unpleasant metallic taste, and are poisonous.

Silver Chloride, AgCl , occurs as the mineral cerargyrite or horn-silver, which crystallizes in octohedrons and other forms of the regular system, but is more frequently found as a massive wax-like mass, which generally has a pearl-grey colour, though sometimes it possesses a whitish and sometimes a violet-blue colour. It occurs at Andreasberg, mixed with alumina, as an earthy mass which is called butter-milk ore, and this ore was known to the older mineralogists. Gesner, in 1565, terms horn-silver "Argentum cornu pellucido simile," and Matthesius, in his *Berg-Postilla*, published in 1585, terms it "glass-ore, transparent like horn in a lantern." The largest masses are brought from Peru, Chili, and Mexico, and the mineral also occurs in Cornwall, in Nevada, where it is abundant, in Arizona, and other localities. The method of preparing silver chloride artificially was probably known to the old alchemists, but it is first distinctly spoken of by Basil Valentine, who says: "Common salt throws down γ ." This precipitate was afterwards termed *Lac argenti*, and when it was found that it was fusible, and solidified to a transparent horn-like mass, the name *Luna cornea*, first mentioned by Croll in 1608, was given to it. Libavius stated that the substance obtained by precipitating silver solution with common salt weighed less than the silver itself, but this statement was contradicted by Boyle; and Kunkel in his *Laboratorium Chymicum*, speaking of this, says that many substances are difficult to separate from one another: "Such is seen in γ cornea, as 12 loth γ retain out of the common salt, 4 loth terra and salt." This determination is in fact very correct, for twelve parts of silver form 15.94 parts of silver chloride.

Silver chloride is formed, without the phenomenon of incandescence, when chlorine is passed over silver at a dull red-heat (Stas). It is also formed by the action of hydrochloric acid on the ignited metal, whilst on the other hand hydrogen is able to reduce silver chloride to the metal (Bonssingault). Aqueous hydrochloric acid converts the surface of metallic silver into chloride of silver, and common salt solution acts in a similar way. Proust examined some piasters which had for many years lain at the bottom of the sea, and he found that the whole of the silver was converted into chloride. In order to prepare pure chloride of silver a solution of the nitrate is precipitated by hydrochloric acid or common salt; in this way a white curdy precipitate is obtained which, on standing, or more quickly on agitation, becomes powdery. This precipitate must be washed and dried in absence of light. It has a specific gravity of 5.5. On heating, silver chloride assumes a yellow colour, melts at 260, forming a dark yellow liquid. This solidifies on cooling, forming a botryoidal, colourless, tough, solid mass which refracts light strongly, and is so soft as to take impressions of the nail. It possesses a specific gravity of 5.594 (Schröder).

According to Stas¹ fused chloride of silver is absolutely insoluble in water at the ordinary temperature, or at any rate its solubility does not reach the limit of our present tests for chlorine which Stas places at 1 in 10,000,000. In boiling water, on the other hand, it is slightly soluble. The precipitated curdy chloride is also slightly soluble in cold water; its solubility, however, is less when the precipitate has become powdery either by standing or shaking. The solution becomes opalescent on the addition of either silver nitrate or hydrochloric acid. The presence of nitric acid does not affect the solubility of the curdy chloride, whereas the solubility of the powdery form increases proportionally to the amount of nitric acid added. One part of silver chloride dissolves in about 200 parts of concentrated hydrochloric acid, and in 600 parts of the acid diluted with an equal bulk of water. Soluble chlorides, such as sal-ammoniac and common salt, dissolve silver chloride tolerably easily, and it is very soluble in ammonia, 1288 parts of this substance of specific gravity 0.89 dissolving 1 part of the chloride of silver (Wallace and Lamont). On evaporating this ammoniacal solution silver chloride crystallises out in glittering octohedrous. It is likewise dissolved in quantity by mercuric

¹ *Compt. Rend.*, lxxiii. 998.

nitrate and by potassium thiosulphate, with formation of silver-potassium-thiosulphate, and potassium chloride. Potassium cyanide also dissolves silver chloride.

When heated with charcoal before the blowpipe it is easily reduced to metal, but it is not decomposed when heated with charcoal.

Various metals, such as iron, zinc, &c., reduce the chloride to the state of metal in the presence of water. This takes place quickly especially in presence of hydrochloric acid and sulphuric acid. It is also decomposed by mercury when a solution of common salt is present. Cold sulphuric acid does not act upon it, but it is decomposed slowly, though completely, by the boiling acid with evolution of hydrochloric acid.¹ Concentrated hydroiodic acid decomposes it with evolution of heat into silver iodide (Deville), and if moist, freshly precipitated chloride be treated with a solution of bromide of potassium, or iodide of potassium, it is completely decomposed into silver bromide or iodide.² 100,000 parts of concentrated nitric acid dissolve 2 parts of the freshly prepared silver chloride (Thorpe): on boiling, it is decomposed into nitrate with evolution of chlorine.

White silver chloride obtained by precipitation when exposed to light is first coloured violet, then brownish grey, and afterwards black. This alteration in colour was known to Boyle,³ who, however, ascribed it to the action of the air. Scheele⁴ afterwards proved that it was only decolorised on exposure to light, and he also showed that in this reaction hydrochloric acid was liberated, and that on treating the residue with ammonia, black flakes of silver remained behind. It was then believed that both light and moisture acted upon the chloride, but Berzelius showed that it is also blackened when exposed to light in hermetically sealed glass tubes, in the perfectly dry state, and proved that chlorine was liberated. He also pointed out that no blackening takes place when the silver chloride is kept under chlorine water, but that a discoloration begins as soon as the whole of the chlorine has been converted into hydrochloric acid. The same thing is observed when the chloride is exposed to light under chloride of iron or cupric chloride solutions. It has long been thought that the black substance thus formed was sub-chloride, but according to the later experiments of Bibia,⁵ it would seem that this is not the case, for although chlorine

¹ *Sauer, Zeitsch. Anal. Chemie*, 1873, p. 376.

² *Frold, Quart. Journ. Chem. Soc.* x. p. 234.

³ *Op.* l. 756.

⁴ *Von der Luft und dem Feuer*, Leipzig, 1784, p. 64.

⁵ *Journ. Pract. Chem.* cxxii. 39.

undoubtedly escapes, the quantity is so small that it cannot be weighed.

It has also been noticed that the darkening of silver chloride takes place much more rapidly when a substance is present which is capable of combining with chlorine; this is well seen in the case of stannous chloride, which possesses this power in a high degree.

216 Silver Sub-chloride. This compound was obtained by Wöhler, by treating silver tetrantoxide or its citrate with hydrochloric acid. The formula is supposed to be Ag_2Cl or Ag_3Cl_2 , but according to Bibra, it has the composition Ag_4Cl_3 . It is a black powder which, on heating, diminishes in bulk without losing weight and is decomposed by ammonia and nitric acid into silver and silver chloride, when the chloride and the metal are respectively dissolved.

Silver Chloride and Ammonia, $2AgCl + 3NH_3$. Glauber states that a calx is formed when silver solution is precipitated by common salt, and he adds that the calx "readily dissolves in *spiritu urinæ, salis armoniaci, cornu Cervi, succini, fuliginis et capallorum*, and may be used to form a good medicament." Faraday,¹ first obtained this substance by the direct union of ammonia and silver chloride by saturating dry precipitated silver chloride with ammonia; 100 grains or 6.48 grams absorbed 130 cubic inches or 2.13 liters of the gas. According to Rose,² the increase of weight amounts to from 17.31 to 17.91 per cent., corresponding to the above formula. The absorbed ammonia is again given off at $37^{\circ}7$ (Faraday). When heated in a closed tube for the purpose of obtaining liquid ammonia, the compound fuses between 88° and 95° , swells up, begins to boil at 99° , losing ammonia and gradually becoming white. When a solution of silver chloride in concentrated ammonia is allowed to stand in an imperfectly closed bottle, large transparent rhombohedrons are obtained which blacken on exposure to light, and when acted on by air or water, give off their ammonia, being converted into white friable chloride of silver. (Faraday).

Silver Bromide, $AgBr$, occurs in Chili and Mexico as the mineral bromargyrite, being usually found in small yellow or greenish masses, rarely crystalline. The mineral embolite is a mixture of silver chloride and bromide, varying from three of the latter to one of the former to the reverse proportion. It likewise occurs in Chili and Mexico, and is very similar to the

¹ *Quart. Journ. of Science*, v. 74 (1818).

² *Pogg Ann.* xx. 157.

foregoing mineral. When an excess of silver nitrate is precipitated in the dark with hydrobromic acid, a white curdy precipitate is obtained which in contact with potassium bromide, or on heating, becomes yellow. It is soluble in a hot solution of hydrobromic acid, and in a solution of mercuric nitrate separating out in octohedrons from these solutions on cooling. It is scarcely soluble in dilute ammonia, but easily soluble in concentrated ammonia. It melts, on heating, to form a reddish liquid which solidifies to a yellow lustrous mass; and this, when heated in a current of chlorine, is slowly converted into chloride. The finely divided precipitate suspended in water is instantly decomposed by chlorine, and hydrochloric acid gas also decomposes it at 700° with evolution of hydrobromic acid. Whilst the fused bromide is hardly acted upon by light, the precipitated salt is soon coloured a greyish-violet on exposure to light; if, however, it contains a trace of free bromine, it is unacted on. The action is also lessened by the presence of nitric acid, whilst it is increased by the presence of silver nitrate. Dry silver bromide absorbs no ammonia;¹ on the other hand, the ammoniacal solution deposits on standing white glistening crystals, and these lose on heating ammonia.²

217 *Silver Iodide*, AgI. This salt occurs as iodargyrite, in Mexico, Chili, Spain, and in the Cerro Colorado Mine in Arizona, in the form of slightly elastic hexagonal tables. Silver combines directly with iodine on heating. The metal also dissolves in hydriodic acid, with violent evolution of hydrogen, and if the liquid be warmed, as soon as the action becomes lessened the evolution again increases, and on cooling colourless crystalline scales separate out. These on exposure to air decompose quickly, and probably possess the formula $AgI.HI$. The mother-liquor on standing, deposits thick hexagonal prisms of silver iodide.³ The same compound is formed by the action of concentrated hydriodic acid on silver chloride. It is also formed by the treatment of the chloride or bromide of silver with aqueous potassium iodide, and other soluble iodides which decompose silver chloride and bromide, silver iodide being deposited as a light yellowish powder. It melts at a dull red-heat forming a yellow liquid, which on further heating becomes red and then a dark reddish-brown colour, and on cooling solidifies to a yellow soft mass having a specific gravity of 5.687 at 0°

¹ Rammelsberg, *Fogg.* lv. 248.

² Liebig, *Schweiz. Journ.* xlviii. 103.

³ H. Deville, *Comp. Rend.* xxxii. 894.

(Deville), whilst the crystalline variety has at 14° a specific gravity of 5.669, that of the precipitated salt being 5.596 (Damour). An interesting fact with reference to the abnormal expansion and contraction of silver iodide by heat has been observed by Fizeau;¹ it contracts when heated from -10° to $+70^{\circ}$, and expands on cooling. This is explained by Rodwell,² by the fact that silver iodide exists in two allotropic modifications.

Pure silver iodide is left unaltered by the action of direct sunlight. If, however, it be precipitated from an excess of silver nitrate so that traces of this salt are carried down with it it becomes coloured green on exposure to light, and in presence of more silver nitrate, a deep greyish-black colour is attained, although no loss of iodine is observed (Stas). Iodide of potassium and nitric acid having a specific gravity of 1.2 have the power of reproducing the yellow colour. The changes effected by light upon silver iodide are brought about chiefly in the presence of substances which have the power of combining with a portion of the iodine. Ammonia changes the yellow colour of silver iodide to white and dissolves it very sparingly. It differs from the chloride and bromide of silver, inasmuch as it is difficultly soluble even in concentrated ammonia. According to Wallace and Lamont, one part of the iodide dissolves in 2493 parts of ammonia of specific gravity 0.89. It is tolerably soluble in a strong solution of potassium iodide, from which solution it is precipitated on the addition of water. A hot solution of potassium iodide saturated with silver iodide, deposits on standing white needles of a salt having the composition AgI.KI . When silver iodide is gently heated in chlorine gas, it decomposes into silver chloride and the same reaction takes place when it is treated with dry hydrochloric acid at 700° , (Hantfeuille). It is only incompletely reduced in a current of hydrogen even when exposed to a white-heat (Vogel). The dry precipitated iodide absorbs 3.6 per cent. of ammonia gas forming a white compound, 2AgI.NH_3 , which on exposure to air gives off ammonia and turns yellow again.³

Silver Fluoride, AgF , is obtained by dissolving silver oxide or carbonate in aqueous hydrofluoric acid and evaporating to dryness. Hydrofluoric acid does not act upon metallic silver. If the solution is allowed to evaporate in a vacuum, colourless lustrous,

¹ *Comp. Rend.* lxiv. 301

² *Chem. News*, xxxl. 4.

³ Rammelsberg, *Fogg.* xlviii. 170.

deliquescent, quadratic pyramids are deposited, having the composition $\text{AgF} + \text{H}_2\text{O}$ (Marignac). The concentrated solution when allowed to stand exposed to the air, deposits hard transparent prisms of the compound $\text{AgF} + 2\text{H}_2\text{O}$, which are nearly as deliquescent as calcium chloride. It is extremely difficult to obtain silver fluoride in the anhydrous state. The hydrate $\text{AgF} + \text{H}_2\text{O}$ decomposes when dried in a vacuum and yields a brown amorphous mass which still contains 1.5 per cent. of water, and dissolves in 0.85 parts of water at 15°C . When heated to the melting point of lead in a covered crucible, 0.5 per cent. less than the calculated quantity of water is given off together with some hydrofluoric acid and oxygen :



This decomposition goes on until all the water is driven off and the salt melted, and from this point it can be heated in absence of air up to the melting point of silver without any further decomposition taking place.¹ The fused salt solidifies to a black mass which is elastic and may be cut with scissors. In the fused state it conducts electricity without being decomposed. The dry pulverulent salt absorbs 844 times its volume of ammonia.

218 Silver Chlorite, AgClO_2 . is obtained by precipitating a weak alkaline solution of a chlorite with silver nitrate. It forms a crystalline powder which separates from a solution in hot water in crystalline scales. These deflagrate when moistened with concentrated hydrochloric acid or when heated to 105° ; they also take fire when mixed with sulphur (Millon).

Silver Chlorate, AgClO_3 . This salt is obtained when chlorine is passed into water through which silver oxide is diffused; until bubbles of oxygen are evolved; the chloride of silver is filtered off and the liquor evaporated to its crystallizing point. The filtrate first contains silver hypochlorite, which however decomposes in the dark at 60° as follows :

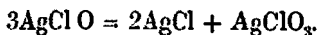

The chlorate may also be obtained by dissolving silver oxide in chloric acid, the action being accompanied with evolution of heat. It crystallizes in white opaque quadratic prisms, having a specific gravity of 4.43. These dissolve in about 10 parts of cold water and melt at 230° ; when further heated to 270° they

¹ *Ann. Chem. Phys.* 1871, p. 321.

give off oxygen and a trace of chlorine. When mixed with sulphur it detonates with the utmost violence on friction.

Silver Sulphite, Ag_2SO_3 , is a white curdy precipitate almost insoluble in water and sulphurous acid, decomposing when heated to 100° into silver and silver sulphate.

Normal Silver Sulphate, Ag_2SO_4 . This substance was obtained in solution by Glauber, for he states in his *Furnis novis philosophicis* (1648), "*Dissolve rasuram*) in a rectified oil of vitriol, with the addition of a sufficiency of water, but not so much as in the case of Mars or Venus. Or, still better, dissolve a calx of) which is precipitated from aqua fortis, either by copper or by spirits of salt."

It is best obtained by heating the reduced metal with sulphuric acid, or by dissolving the carbonate in dilute sulphuric acid. It crystallizes in the rhombic system, the small crystals being anhydrous, and shining. They are isomorphous, with anhydrous sodium sulphate,¹ and have a specific gravity of 5.4 and dissolve in about 200 parts of cold and 68.35 parts of boiling water. In consequence of the difficult solubility of the salt, it is obtained as a precipitate when sulphuric acid or a soluble sulphate is added to a silver solution, and this fact was known to Boyle.² It is easily soluble in water containing sulphuric acid, and still more soluble in nitric acid. It also dissolves readily in strong sulphuric acid, being precipitated from this solution on the addition of water. It fuses at a dark red-heat and decomposes at a very high temperature into metal, oxygen, and sulphur dioxide. When dissolved in less than three parts of sulphuric acid, light yellow prisms of hydrogen silver sulphate, HAgSO_4 , are obtained.

Silver Thiosulphate, $\text{Ag}_2\text{S}_2\text{O}_3$, is obtained by adding a moderately dilute solution of silver nitrate gradually to an excess of concentrated solution of sodium thiosulphate, washing the precipitated grey mixture of thiosulphate and sulphide with cold water, extracting the thiosulphate with ammonia, precipitating it as quickly as possible by exact neutralization with nitric acid and quickly drying it by pressure between filter paper.³ It forms a snow-white powder, having a sweet taste, and is slightly soluble in water, and in the moist condition

¹ Mitscherlich, *Pogg.* xii. 138.

² "Considerations and Experiments touching the origin of qualities and forms," Boyle, *Op.* lii. 66.

³ Herschel, *Edin. Phil. Journ.* I. 26 ; 11. 151.

it easily decomposes into sulphuric acid and sulphide of silver (Rose):

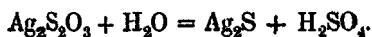

Silver Sodium Thiosulphate, AgNaS_2O_3 , was discovered by Herschel,¹ and may be obtained by evaporating a solution of silver chloride in aqueous sodium thiosulphate, until it crystallizes. It is, however, best formed by adding a neutral solution of silver nitrate to a solution of sodium thiosulphate, until a permanent precipitate is produced. The solution is then filtered and alcohol added, when the salt is precipitated in silky laminae (Lenz). Its solution, evaporated in a vacuum, deposits tabular crystals of the salt. It is soluble in water and possesses a sweet taste (Herschel).

219 *Silver Nitrate*, AgNO_3 . This salt was obtained in the crystalline form by Geber: "Dissolve) calcinatam in aqua dissolutiva, quo facto, eoque eam in phiala, cum longe collo, non obturato ori per diem solum, usque quo consumetur ad ejus tertiam partem aquae, quo peracto pone in loco frigido, et devenient lapilli ad modum crystalli fusibiles." At the end of the seventeenth century, Angelus Sala, drew the attention of the iatro-chemists to this salt known as *crystalli dianæ* or *magisterium argenti*, to which when cast into sticks, the name of *lapis infernalis* or *lunar caustic* was given.

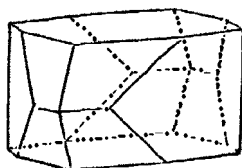

FIG. 107.

Silver nitrate is obtained on the large scale, by dissolving silver in dilute nitric acid, and occurs in commerce both in crystals and cast into sticks (lunar caustic). It crystallizes in transparent rhombic plates (Fig. 107), having a specific gravity of 4.328 (Schröder) and melting at 198°, solidifying on cooling to a white fibrous crystalline mass. It possesses an acrid metallic taste, and acts as a violent poison, blackening and destroying organic matter, but it does not blacken in the air except in contact with organic substances. When it is wrapped up in paper for some time it gradually decomposes, leaving a residue of metallic silver, and at a red-heat it yields nitrogen peroxide, oxygen, nitrogen, and metallic silver. According to Kremers,² 100 parts of water dissolve as follows:

¹ *Loc. cit.*

² *Pogg. Ann.* xcii. 497.

At	0°	19°5	54°	85°	100°
AgNO ₃	121·9	227·3	500	714	1,111 parts.

The aqueous solution has a neutral reaction. If ammonia is added to a solution of silver nitrate until the precipitate first formed redissolves, and this solution be then allowed to evaporate, fine bright rhombic prismatic crystals, having the composition $\text{AgNO}_3 + 2\text{NH}_3$, are deposited. These do not give off ammonia at 100°, but when more strongly heated they melt, evolving nitrogen and ammonia, whilst ammonium nitrate and a metallic mirror of silver are left behind. When a current of dry ammonia is passed over dry silver nitrate, this substance absorbs 29·55 per cent. of the gas, enough heat being developed to produce fusion of the mass. The product of this reaction is a white solid soluble in water and possessing the formula $\text{AgNO}_3 + 3\text{NH}_3$ (Rose).

Silver nitrate is largely used in chemical analysis and especially in photography. It is also employed in medicine, both externally and internally. For external application it acts as a powerful caustic, inasmuch as it unites with the albuminoid substances to form insoluble compounds. Large doses given internally, act corrosively upon the mucous membranes, producing serious inflammation. Experiments on animals have shown that it produces paralysis of the nerve centres, difficulty of breathing, and coma. It is given in doses of from 0·02 grams in chronic stomach diseases, epilepsy and other nervous affections. When administered for some length of time, it produces a peculiar bronze colour of the skin, caused by the deposition of metallic silver under the cuticle.

Silver Nitrite, AgNO₂. This substance was first obtained by Proust, who considered it as the nitrate of silver suboxide, having obtained it by boiling silver nitrate with the powdered metal. As this salt is only slightly soluble in water, it is best prepared by double decomposition of a solution of silver nitrate with potassium or barium nitrite. According to V. Meyer,¹ lukewarm concentrated solutions of twenty-four parts of silver nitrate and fifteen parts of potassium nitrite are mixed and allowed to cool. The salt thus obtained is easily washed on the filter-pump. It is a white crystalline powder, more difficultly soluble in cold water than silver sulphate. In hot water it dissolves more readily, but partially decomposes

¹ Liebig's *Ann.* clxxi. 23.

and crystallizes on cooling, in needles or oblique prisms, which appear colourless in the liquid, but on drying acquire a yellowish tint and a fatty lustre.

220 Phosphates of Silver. The normal phosphate, Ag_3PO_4 , is formed as a yellow precipitate, when a silver salt is added to a solution of the normal or the mono-hydrogen sodium phosphate. On heating, its colour changes to brown, and it melts at a red-heat. It is soluble in aqueous phosphoric acid, yielding the mono-hydrogen salt, HAg_2PO_4 , which is deposited in the form of white crystals. The pyrophosphate, $\text{Ag}_4\text{P}_2\text{O}_7$, is a white precipitate, melting below a red-heat, to form a dark-brown liquid which solidifies to a colourless fibrous mass. When heated for some time with aqueous phosphoric acid, the dihydrogen pyrophosphate, $\text{H}_2\text{Ag}_2\text{P}_2\text{O}_7$, is formed as a crystalline powder, which is decomposed on the addition of water. The metaphosphates of silver are white precipitates.

Arsenites and Arsenates of Silver. The normal arsenite, Ag_3AsO_3 , is a canary yellow powder, easily soluble in nitric acid and ammonia. When the ammoniacal solution is boiled, metallic silver separates out. The normal arsenate, Ag_3AsO_4 , is a dark red-brown crystalline precipitate, formed by precipitating a concentrated solution of arsenic acid with a boiling solution of silver nitrate. The same substance is precipitated as a brownish-red powder, if a solution of an arsenate is added to silver nitrate.

Silver Carbonate, Ag_2CO_3 , is a light yellow powder of a paler colour than the phosphate, which readily becomes black on exposure to light, or on heating, and loses all its carbon dioxide at 200° . When a mixture of *ammonio-nitrate of silver* and caustic potash is exposed to the air, silver oxide separates out, and after a time lemon-yellow needles of the carbonate.

Silver Cyanide, AgCN , is a white curdy precipitate, insoluble in dilute nitric acid but easily soluble in ammonia. It forms soluble double salts with the cyanides of the alkali, and alkaline earth metals.

Potassium Silver Cyanide, $\text{KAg}(\text{CN})_2$, crystallizes in feathery tufts or six-sided prisms, and is soluble in 4 parts of water at 20° .¹ It does not undergo alteration on exposure to light.

Silver Cyanate, AgOCN , is a white precipitate easily soluble in ammonia and nitric acid. On heating it explodes, a dull white mass of silver carbide remaining behind. This decomposes,

¹ *Laup. Ann. Chist. Phys.* [3] lvi. 462.

on solution in nitric acid, leaving a finely divided network of pure carbon.¹

Silver Thiocyanate, AgSCN , is a white curdy precipitate, easily soluble in ammonia, crystallizing from the solution in glistening scales, which do not contain any ammonia.

Potassium Silver Thiocyanate, $\text{KAg}(\text{SCN})_2$, is formed when the foregoing salt is dissolved in a solution of potassium cyanide. It crystallizes in rhombic octohedrons, and is decomposed by water.

SILVER AND SULPHUR.

221 *Silver Sulphide*, Ag_2S , occurs as argentite, or vitreous silver. The occurrence of this ore was known to Agricola: "Argentum rude plumbei coloris et galenæ simile." This important silver ore, occurring in blackish-grey crystals, belonging to the regular system, occurs widely distributed, but is found especially in the Erzgebirge, in Hungary, in Norway near Kongsberg, in the Altai, in the Urals, in Cornwall, Bolivia, Peru, Chili, Mexico, and in Nevada, at the Comstock lode. This compound occurs in the Erzgebirge, in two distinct forms; one of these is termed daleminzite, and the other acanthite; the first of these being isomorphous with chalcocite. Argentite can be obtained artificially, by igniting silver chloride in a current of sulphuretted hydrogen. Silver sulphide is also formed when silver is heated with sulphur or sulphuretted hydrogen, and forms the yellow or brownish stains which are formed on articles of silver on exposure to the air (Proust). Sulphuretted hydrogen produces in solutions of silver a blackish brown flocculent precipitate of silver sulphide which is soluble in hot nitric acid, and is converted into silver chloride when a solution of copper chloride in the presence of common salt is added to it.

THE ACTION OF LIGHT ON SILVER SALTS. DAGUERRETYPE AND PHOTOGRAPHY.

222 The observation of Boyle, that silver chloride and other silver salts undergo blackening on exposure to light, the chemical explanation of which was first given by Scheele, has led to the foundation of the important art of photography. The first light-pictures were obtained by Thomas Wedgwood, in the year 1802.

¹ Liebig and Redtenbacher, *Ann. Pharm.* xxxviii. 129.

These were simply prints of leaves or paintings on glass, prepared by allowing the light to fall through a more or less transparent object on to white paper, or leather, which had been moistened with nitrate of silver. Davy, repeating these experiments, obtained fairly accurate copies of leaves, wings of insects, and similar objects, and even succeeded in preparing pictures of small objects which had been magnified by the solar microscope. The pictures thus obtained could not be exposed to day-light, but had to be examined by candle-light, as at that time no process was known by which that portion of the silver salt unacted upon by the light could be withdrawn, and thus the picture rendered permanent. The first experiments which had for their object rendering the photographic image permanent were made by Niepce, who began his investigations in the year 1814. In the year 1826 he, together with Daguerre, investigated the same subject, and it is to the latter experimenter that we are indebted for the first process by which the image obtained in the camera can be fixed. In 1839 he discovered the process which now bears his name. This consists in allowing the vapour of iodine to act upon a polished surface of silver, which thus becomes coated with a film of silver iodide. The surface of the plate thus prepared is next exposed to light in the camera. After a short time the light has produced its action, although on the removal of the plate no change of the surface is perceptible. If the plate be now exposed to the action of the vapour of mercury, the picture makes its appearance, inasmuch as the mercury is deposited in extremely fine globules on those portions of the plate on which the light has fallen, whilst in the shadows, the unaltered iodide remains. The plate must next be dipped into a solution of sodium thiosulphate, in order to remove those portions of the iodide which have been unacted upon by the light.

The Daguerreotype process has undergone many alterations, but it has now been altogether superseded by the much more valuable art of Photography. In the year 1839, Mr. Fox Talbot published his method of photogenic drawing, or photography, on paper. This process, which was but an imperfect one, consisted in exposing in the camera a paper soaked in a weak solution of common salt and afterwards washing over with a solution of silver nitrate. The image obtained was a negative one; that is, the light portions of the landscape were dark, and *vice versa*. These pictures were fixed by immersion

in a solution of common salt. A great improvement was made in this process by Talbot, in the year 1841, by coating the paper which was to be acted upon with a film of silver iodide by first dipping it into nitrate of silver solution and then into one of potassium iodide. This paper does not exhibit any change after exposure in the camera, but on "development" with a mixture of silver nitrate, acetic acid and gallic acid, the image becomes visible. The picture is a negative, but it may be rendered transparent by saturating it with white wax, and then a positive print may be prepared from it by placing it on a paper moistened with chloride of silver, and exposing it to sunlight. This method was long known as the Talbotype or Calotype process.

A most important improvement in photography was made by Archer, in the employment of a transparent film of iodized collodion spread upon glass as a sensitive film for the camera in place of the iodized paper used in the Talbotype process. Collodion consists of a solution of gun-cotton or pyroxylic acid in a mixture of alcohol and ether, and to this a certain proportion of an iodide or bromide solution in alcohol and ether is added. On pouring this solution on to the plate the ether and alcohol evaporate, and the plate becomes coloured with a homogeneous film. The collodionized plate is next dipped into a bath of nitrate of silver, and the plate thus "sensitized" is exposed in the camera. The image produced on the film is, in this case also, latent, and requires to be developed, or made visible, by treating the surface with reducing agents, such as ferrous sulphate or pyrogallol, compounds which have the power of reducing the sub-iodide to the condition of metallic silver. The unaltered iodide may be removed by dissolving it in cyanide of potassium, and from the negative thus obtained any number of positive prints can be prepared, each of which is afterwards fixed in sodium thiosulphate. The application of collodion renders the process much more certain, shortens the necessary exposure to a few seconds, and admits of a far greater degree of precision in the reproduction of detail than was possible on the rougher surface of paper in the Talbotype.

For a full account of the theory and practice of photography, the reader is referred to Abney's *Treatise on Photography*.¹

It has been already stated, under Silver Chloride, that even up to the present time we cannot satisfactorily account for the

¹ *Longman's Text-Books of Science*, 1878.

chemical changes which take place when silver chloride is blackened by the light, nor can we explain why the bromide and iodide of silver exposed to the light under certain conditions sometimes are affected and sometimes remain unaltered. The production of the latent image shows that the silver salt undergoes change, and it is not impossible that the invisible change thus produced on the film may resemble that observed when light is allowed to fall on a mixture of chlorine and hydrogen. For these gases, which combine on insolation, require to be exposed to light for a certain length of time before any combination whatever takes place, this peculiar phenomenon being termed photo-chemical induction (Bunsen and Roscoe). In the case of the photographic image, the film undergoes a modification such as to render it susceptible to decomposition in presence of a reducing agent.

223 *Production of a Photographic Paper of Constant Sensitiveness.*—Bunsen and Roscoe,¹ have shown that by adhering to a certain method of manipulation it is possible to prepare standard chloride of silver papers which possess a constant degree of sensitiveness; so that if the same light falls upon them the papers are always coloured to the same tint. It also appears that the tint attained by such a paper was constant when the quantity of light falling upon it also remained constant. Thus, that light of the intensity 50 falling upon the paper for the time 1, produced the same shade of blackening as light of the intensity 1 acting for the time 50. Upon these facts Bunsen and Roscoe have founded a method for attaining measurements of the chemical action of light. For this purpose an arbitrary unit of measurement is chosen by making a standard tint easily reproducible at any time. The quantity of light which shall in the unit of time produce a blackening effect on the standard photographic paper is said to have the chemical intensity 1. If the time needed to produce this same effect is found by experiment to be 2 units, then the chemical intensity is one-half, and so on. The results of measurements of total chemical intensity obtained by this method at various places have been published by Roscoe.²

Relative Sensitiveness of Different Photographic Papers.—From experiments made by Mac Dougall³ and Wright,⁴ it appears that

¹ *Phil. Trans.* 1863, 139.

² *Phil. Trans.* 1867, 555; *ibid.* 1874, part ii.

³ *Chem. Soc. Journ.* [2], iii. 183.

⁴ *Ibid.* [2], iv. 33

the sensitiveness of a photographic paper depends solely upon the quantity of the chlorine or bromine contained in the salting solution, and that it is not influenced by the metal with which the halogen is combined.

224 *Action of Light of Different Degrees of Refrangibility on the Salts of Silver.*—Scheele observed that the violet rays of the solar spectrum are those which affect silver chloride most strongly, and to these the name of the chemical rays has frequently been given. It has, however, recently been shown that all the rays of the solar spectrum are able, under certain circumstances, to effect chemical change, each particular chemical compound being decomposed by the rays upon which it is most capable of exerting an absorbent action. Not only is this the case, but an admixture with the sensitive compound of certain coloured, but chemically inactive, substances has the effect of altogether altering the position of the maximum of chemical action of that particular substance. Thus, for example, it is possible by the addition of a yellowish-red colouring matter, such as aurin, to the bromide-film to prepare a plate which is affected as much by the yellow rays, which are usually considered chemically inactive, as by those in the violet. In this way Draper,¹ Vogel,² and Abney,³ have succeeded in photographing the lines of the visible solar spectrum from *b* downwards, and have not only secured pictures of the portions included between the lines *E* and *A*, but have obtained photographic action even in the ultra-red regions.

DETECTION AND ESTIMATION OF SILVER.

225 There is probably no element whose presence can be more readily detected than that of silver, owing to its chloride being insoluble in water and easily soluble in ammonia. In order to detect silver in an insoluble compound, it may be melted with carbonate of soda on charcoal before the blow-pipe or heated on the end of a carbonized lucifer-match in the reducing flame of the Bunsen burner. Silver is then obtained in the metallic state as a bright shining bead, which easily dissolves in warm nitric acid, the solution giving on the addition of hydrochloric acid a curdy precipitate of silver chloride, or, if only a trace of silver be present, a mere opalescence

¹ *Phil. Mag.* [5] iii. 86.

² *Pogg. Ann.* 1877.

³ *Phil. Mag.* [5] v. 61.

will be seen. This disappears on the addition of ammonia, but is reproduced when the ammonia is neutralized with hydrochloric acid.

The spark spectrum of silver is obtained by the use of the metal as poles with a powerful discharge. It may also be seen when platinum poles are moistened with nitrate of silver solution. Two bright green lines are the most characteristic in its spectrum, and several weaker lines occur in both the blue and the violet.

226 Silver is almost always estimated quantitatively as the chloride. The precipitate after washing and drying is heated in a porcelain crucible until it begins to melt and then its weight is obtained. In order to determine the small quantity of chloride which sticks to the filter, the whole is burnt, the chloride being reduced to metallic silver. The weight of metallic silver and ash is thus obtained, and by subtracting the weight of the latter we get the weight of metallic silver present; this is then calculated into chloride, and the number thus obtained added to the weight of the chloride already found.

In some few cases the silver is determined as the cyanide or sulphide, and, in the case of organic silver salts, the metal which remains behind on heating the salt is weighed.

Silver can also be easily determined volumetrically with standard hydrochloric acid, common salt solution, or potassium thiocyanate (Vol. I. p. 673). In the mints, where a large number of silver assays have to be made daily, a method proposed by Gay Lussac¹ is now almost universally adopted. In this process the alloy is dissolved in nitric acid, and the silver precipitated from solution in the form of chloride, the volume of the standard solution necessary for the complete precipitation of the silver being ascertained. Chemically pure silver is required for this purpose; this is best used in the form of thin foil; then a normal solution of common salt is needed of such a strength that 100 cc. correspond exactly to one gram of silver; thirdly, a decinormal salt solution prepared by diluting one volume of the normal solution with nine volumes of water, and lastly, a decinormal silver solution obtained by dissolving one gram of silver in pure nitric acid and diluting this to one liter. All these solutions must be made with care, and their strength very accurately ascertained. Equal volumes of the two decinormal solutions must precipitate one another exactly, so that neither

¹ *Instruct. sur l'Essai des Matières d'Argent par la Voie Humide.* Paris, 1833.
VOL. II. 25

chlorine nor silver will remain in solution when they are allowed to stand after having been well shaken (see p. 370). When the amount of silver contained in the alloy is unknown, the approximate percentage is determined by dissolving one gram of the alloy in nitric acid, in a stoppered bottle, diluting with water and then adding normal salt solution from a burette, and shaking the bottle in order that the chloride of silver may separate out in the coherent form. As soon as the point of complete neutrality is seen to be approaching, the decinormal salt solution is employed, and this is added drop by drop until no further precipitation occurs. In most cases, however, the percentage of silver is sufficiently nearly known to permit the exact analysis to be made at once. Let us suppose that the alloy contains ninety per cent. of silver; then $\frac{1.00}{.90} = 1.111$ grams are weighed out and brought into a stoppered glass flask of about 200 cc. capacity; to this about 5 cc. of nitric acid of specific gravity, from 1.25 to 1.26, are added until it is all dissolved. The red fumes are then blown out, 100 cc. of the normal salt solution added, and the bottle shaken vigorously for a few minutes; for this purpose a mechanical arrangement, called an agitator, is employed, in which a large number of assays are shaken at the same time. As soon as the liquid has become clear, 1 cc. of the decinormal salt solution is added; if this produces a considerable precipitate it is again agitated and the addition continued until no further precipitation occurs. If, on the other hand, the first additional quantity of decinormal salt solution produces no further precipitate, the decinormal silver solution is added in the same way until no further precipitate occurs. Supposing, for instance, that the third cc. of the decinormal salt solution produces the precipitate, but the fourth does not do so; we are now uncertain whether the whole of the third or only a part of the third cc. was needed for complete precipitation, and we therefore assume that probably 2.5 cc. were required; the fineness of the alloy is then found as follows:

$$\frac{1.0025 \times 1000}{1.1111} = 902.2$$

Supposing, however, that the first cc. of salt solution did not produce any precipitate, and that 5 cc. of the decinormal solution had to be added before the point of neutrality was reached, then the fineness would be

$$\frac{0.9965 \times 1000}{1.1111} = 896.8 ;$$

a thousand being taken in each case as representing fine silver.

Another method of assaying silver still used, although not so accurate as the method just described, is the assaying of silver by cupellation. Every silver article made in this country, previously to being sold, is tested at Goldsmiths' Hall, and, if approved, is stamped. This process depends on the fact that the metals alloyed with silver oxidize in the presence of lead oxide at a high temperature, yielding a fusible glass which, together with the oxide of lead, is easily absorbed by the porous cupel, whilst any silver which the mixture contains is left behind in a bright globule which can be accurately weighed. The assay is usually made with one gram of silver. This process of assaying by cupellation, even in experienced hands, may vary as much as two parts in 1,000, whilst Gay-Lussac's process admits of an accuracy of 0.5 in 1,000. The process of cupellation is, however, still in use in lead works, where it is required to determine the amount of silver which marketable lead contains, and it is also used for the estimation of silver in poor ores.

The atomic weight of silver was determined by Stas, together with that of chlorine and potassium; he found that it lies between 107.655 and 107.660.

MERCURY (Hydrargyrum), Hg. = 199.8.

Vapour Density = 99.9.

227 We do not find this metal mentioned either in the books of Moses or in the writings of the older Greek authors. Theophrastus (B.C. 300) speaks of liquid silver or *quicksilver* (*χυρός ἀργυρος*), and says that it is obtained by rubbing cinnabar with vinegar in a copper vessel. Dioscorides in the first century mentions this body as *ἰδράργυρος* (from *ἵδωρ* water and *ἀργυρος* silver), and states that it is obtained by subliming cinnabar and charcoal in an iron pot, upon which a cover is luted. Pliny, who named the material thus obtained *hydrargyrum*, in contradistinction to the native mercury to which he gave the name

of *argentum vivum*, was acquainted with the fact that all solid bodies, with the exception of gold, swim on the surface of the liquid metal. Isidorus, in the beginning of the seventh century, was also acquainted with the properties of mercury, as is seen from the following extract: "Argentum vivum servatur melius in vitreis vasis, nam caeteras materias perforat."

Mercury was known to the older alchemists, who were much interested in the examination of its properties, inasmuch as they believed this body, or some substance closely resembling it, to be one of the component parts of all metals. They were acquainted with the method of purifying it by distillation, and they knew how to prepare many of its compounds. During the epoch of iatro-chemistry, the properties of the mercury compounds were more minutely examined, especially with regard to their medicinal properties; and this explains the fact that of all the metals mercury and antimony were those whose properties became earliest known. Basil Valentine and Agricola both regarded mercury as a metal, but Libavius placed it amongst those "quae metallis sunt affinia," thus connecting it with bismuth, arsenic, galena, cinnabar, and other bodies. Even at a later date many chemists held similar views; thus Brandt in 1735 speaks of it as a semi-metal, indeed it was not reckoned as a true metal until Braune, of St. Petersburg, in the winter of the year 1759, found that it solidifies when exposed to a freezing mixture made of snow and nitric acid.

Mercury occurs in the native state, though in small quantity as compared with its other ores. It is found in globules disseminated through the native sulphide in the Palatinate, in Carnolia, Hungary, Peru, California, and other countries. It also occurs as silver- and gold-amalgam, as the iodide and chloride, and it is found occasionally in certain fullores. The most important ore of mercury is the sulphide or cinnabar. The most celebrated quicksilver mercury mines are those of Idria, in Carnolia; Almaden, in Spain; in California, especially in the Pioneer Mine in Napa Valley; and at Wolfsstein and Landsberg, in the Bavarian Palatinate. Cinnabar is likewise imported into this country from China and Japan.

228 For the purpose of extracting mercury from the ores, a furnace is employed in the Idrian works, shown in Figs. 108 and 109. This consists of a fire (*A*), over which three concentric arches (*aa*, *bb*, *cc*) are built; these are perforated to allow the flame and heated air to pass through, the ore being

placed on the top of the arches. The action of the air and flame on the ore is to volatilize the mercury and oxidize the sulphur to sulphur dioxide. The vapour of the mercury and the gases find their way through the chambers (C, C, C,) in which the mercury is deposited, and the condensed metal flows by the passages (*x y z*) into underground reservoirs. The last chambers (*D* and *E*) serve for the condensation of the aqueous vapour and finely-divided mercury, and this impure dust is collected and again subjected to the process of distillation. In order to collect every trace of mercury a current of water meets the ascending gases in the tower or chamber (*D*).

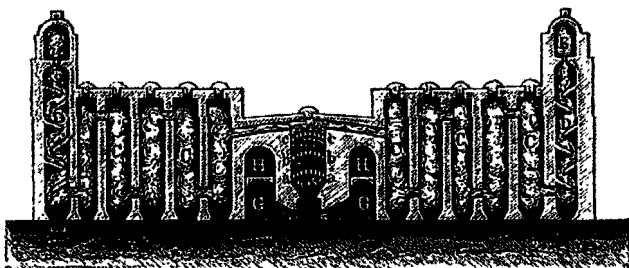

FIG. 103.

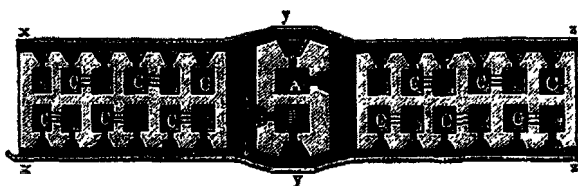

FIG. 109.

The mercury thus obtained is filtered through linen, and exported generally in iron bottles, but sometimes in leather bags. The largest furnace in Idria, erected in the year 1794, is about 10 m. high and 60 m. long; this is charged with from 50 to 60 tons of ores, and yields from 4 to 45 tons of mercury; 40 workmen can fill the furnace in 3 hours, and each distillation lasts 12 hours; but the furnace must be allowed to cool for from 4 to 5 days before it can be charged a second time.

Since 1860 a continuous process has been employed for the reduction of mercury from the ore. For this purpose cylindrical

cal furnaces are used, the grate consisting of movable rods; the furnace is filled with alternate layers of ore and charcoal, and the mercurial vapours pass into condensing chambers through a side flue at the upper end of the furnace, and as the burnt ore is drawn off from time to time, fresh ore and charcoal are introduced at the top to fill up the vacant space. Instead of chambers, a system of tubes, like the atmospheric condensers of the gasworks, has been employed for condensation.

229 A similar process to that employed near Idria is adopted at Almaden, except that the vapours instead of passing through condensing chambers traverse a series of tubes made of earthenware, called *aludels*. These are open at both ends, and fit into one another in a similar way as the condensers employed in the manufacture of iodine. The aludels are arranged one behind the other, first in a descending, and then in an ascending position on arches of masonry (Figs. 110 and 111); the greater part

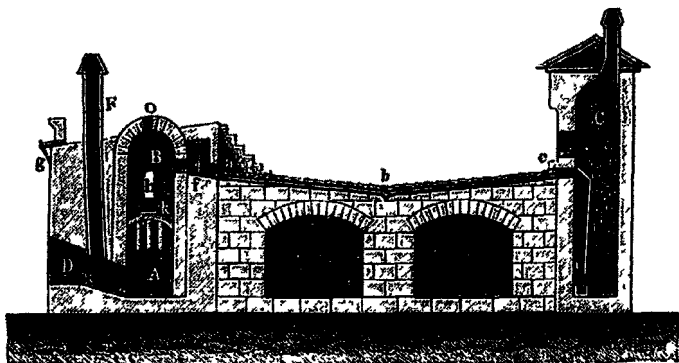

FIG. 110.

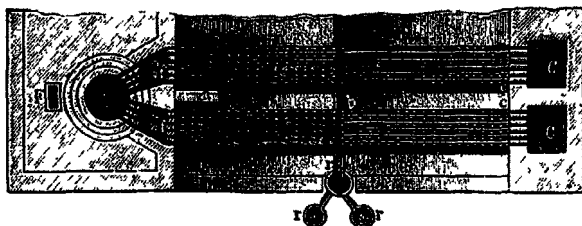

FIG. 111.

of the mercury condenses in and runs from the aludels, *a* (Fig. 111) into the channel *b*, and then into the cisterns (*r r*). The

shape and arrangement of the aludels is shown in Fig. 112. A small quantity of mercury vapour passes on into chamber (C), where it condenses, coming in contact with water contained in the vessel (i.)

In the neighbourhood of Zweibrücken, in the Palatinate, the



FIG. 112.

crude ore, which is a mixture of cinnabar and lime-stone, is heated in long cast-iron or earthenware bottles, (A) (Fig. 113), placed in nearly horizontal rows one above another in a long furnace, and provided with receivers (B), the position of which is shown in the figure. The mercury distils over, and



FIG. 113.

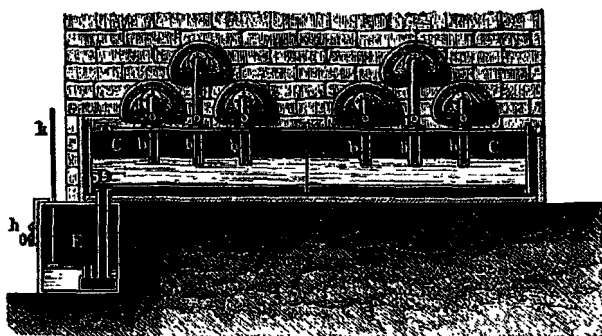

FIG. 114.

a mixture of calcium sulphide and sulphate remains in the retort

In Landsberg an improved apparatus is employed. This consists of a furnace, in which iron retorts (Fig. 114), similar to

gas-retorts, are fixed. To the ends of these retorts tubes (*b*) are connected, and these tubes dip under water contained in an hydraulic main (*O*), from which the condensed mercury runs into the receiver (*E*).

230 The mercury of commerce usually contains a certain proportion of dissolved foreign metals, and these impurities give rise to the "tail" seen when the metal is allowed to run over a slightly inclined surface. Impure mercury, when shaken with air, yields a black powder, caused by the oxidation of the metallic impurities, and this film of oxide incloses a small globule of the liquid metal. The surest mode of freeing mercury from these foreign metals is to distil it, the surface being covered with iron filings to prevent the spitting of the metal, which, however, cannot be completely avoided. It is a curious fact that when small quantities of lead or zinc are present in the mercury the rate of distillation is much diminished; other metals do not possess this retarding influence. Mercury may be more easily purified by treating it with dilute nitric acid, the impurities being the first to dissolve. In order to bring the mercury into contact with the acid it is either exposed in thin layers in a shallow vessel, or is frequently shaken up with the acid. The following improved method for the purification of mercury by means of nitric acid has been suggested by L. Meyer:¹ The metal is allowed to flow in a very thin stream from a small opening in a glass funnel into a wide glass tube 1.25 m. high and 5 cm. in diameter, which contains a mixture of water and 100 cbc. of nitric acid. A narrow tube is fastened to the bottom of this, from which the pure metal flows; it has then only to be washed with water and dried. The above operations may have to be repeated several times, and the metal, if pure, must leave no residue when dissolved in pure nitric acid, evaporated to dryness and ignited.

Pure mercury possesses a silver-white colour. It is liquid at ordinary temperatures, and the globules retain a perfectly spherical shape. The freezing-point of mercury was first determined by Hutchins in 1783, at Fort Albany, in Hudson's Bay Territory, according to instructions received from Cavendish; its melting-point is $-39^{\circ}4$. In the act of freezing, mercury contracts considerably, giving rise to a solid tin-white ductile malleable mass, crystallizing in octohedrons, and capable of being cut with a knife, and having a specific gravity of 14.931.

¹ *Zeitsch. Anal. Chem.* ii. 241.

The liquid metal is transparent when in very thin films and it transmits violet blue light. (Melsens.) When a powerful stream of water is poured from a height of a decimeter on a mass of from 15 to 20 kilos. of mercury, bubbles of the metal, of about 1 cm. in diameter, are seen swimming on the surface of the water. These consist of very thin films of mercury, through which blue light is transmitted; they soon burst, and leave behind a very small solid globule of the metal.

The specific gravity of mercury at 0°, compared with water at 4°, is 13·595 (Kopp), whilst the specific gravity of mercury weighed in a vacuum at 4° is 13·594. (Balfour Stewart.) The boiling-point of mercury, according to Regnault's observations, is 357°·25, the metal giving rise to a colourless vapour, which has a specific gravity, according to the experiments of Dumas, of 6·976, or, according to those of Bineau, of 6·7. In spite of its high boiling-point, mercury volatilizes perceptibly at the ordinary temperature, both in a vacuum and in air, as proved by the silvering of gold-leaf kept for two months in a vessel over mercury (Faraday); and Merget has shown that even at -44°, when mercury is solid, it still possesses a distinct vapour-tension. The tension of the vapour of mercury has been determined by Regnault,¹ and is given in the following table:—

Tem- perature.	Tension in mm.	Tem- perature.	Tension in mm.	Tem- perature.	Tension in mm.
0°	0·0200	180°	11·00	360°	767·74
10	0·0268	190	14·84	370	954·65
20	0·0372	200	19·90	380	1136·65
30	0·0530	210	26·35	390	1346·71
40	0·0767	220	34·70	400	1587·96
50	0·1120	230	45·35	410	1863·73
60	0·1643	240	58·82	420	2177·53
70	0·2440	250	75·75	430	2533·01
80	0·3528	260	96·73	440	2933·99
90	0·5142	270	123·01	450	3384·35
100	0·7455	280	155·17	460	3888·14
110	1·0734	290	194·46	470	4449·45
120	1·5341	300	242·15	480	5072·23
130	2·1752	310	299·69	490	5761·32
140	3·059	320	368·73	500	6520·25
150	4·206	330	450·91	510	7353·44
160	5·900	340	548·35	520	8264·96
170	8·091	350	663·18		

¹ *Comptes Rendus*, lxxiii, 1356.

When mercury is shaken with different liquids, or when it is triturated with sugar, sulphur and other bodies, the liquid metal is obtained in a very finely divided state, being converted into a grey powder. This was formerly termed *Aethiops per se*. This act of fine division is termed the "extinction" or "deadening" of mercury. Grey mercurial ointment is formed by rubbing up mercury and fat together, and in the preparation the mercury is in the form of globules having a diameter of 0.002 to 0.004 mm.

Mercury is largely used in the preparation of physical and chemical apparatus, for collecting gases which are soluble in water, for the preparation of mirror plates, for the amalgamation of silver and gold, and for the preparation of the mercurial compounds.

ALLOYS OF MERCURY OR AMALGAMS.

231 The general properties of these alloys have already been given on p. 9 of this volume.

Potassium Amalgam. Potassium combines with mercury with evolution of heat but without incandescence, forming a silver-white compound, which is liquid when it contains one part of potassium to about seventy parts of mercury, but when it contains more potassium it becomes solid. If the metals be melted together in the right proportions, or if sodium amalgam containing 3 per cent. of the alkali-metal be brought into potash-ley a crystalline compound, $Hg_{24}K_2$, is formed, which in the last mode of preparation is obtained crystallized in very bright shining cubes or dodecahedrons and rhombohedrons.¹ When an amalgam, rich in potassium, is heated to 440° a crystalline compound, HgK_2 , remains behind, which takes fire spontaneously on exposure to air.²

Sodium Amalgam. Sodium combines violently with mercury with evolution of light and emitting a hissing noise. One part of sodium to 100 of mercury forms an amalgam having an oily consistency, but with 80 of mercury to 1 of sodium a pasty mass is obtained, and with smaller quantities of mercury a hard and crystalline amalgam is formed. When an amalgam containing 3 per cent. of sodium is allowed to stand under water, long

¹ Kraut and Popp, *Ann. Chem. Pharm.* clix. 188.

² De Souza, *Ber. Deutsch. Chem. Ges. Ber.* ix. 1050.

needles having the composition $Hg_{12}Na_2$ separate out (Kraut and Popp), and when an amalgam rich in sodium is heated to 440° the crystalline compound Hg_2Na_6 remains (De Souza).

The amalgams of the alkali-metals decompose slowly on exposure to moist air and water, and amalgamate iron and platinum. Sodium amalgam is employed in the processes of extracting silver and gold, and also in organic chemistry as a reducing agent.

Ammonium Amalgam. This compound, discovered at the same time by Berzelius and Pontin,¹ and Seebeck,² is formed when a galvanic current is passed through aqueous ammonia or a solution of ammonium salt containing metallic mercury placed in connection with the negative pole. It is also formed by the action of potassium or sodium amalgam on any stable ammoniacal salt or its solution. The mercury increases from five to twenty times its bulk, forming a butter-like mass which is lighter than water, and crystallizes below 0° in cubes (H. Davy). When cooled by a mixture of ether and solid carbon dioxide it becomes brittle, and of a dark grey colour, and does not decompose spontaneously (Grove). At the ordinary temperature it quickly decomposes into mercury, hydrogen, and ammonia, the relation of the latter being as one to two. According to Landolt, 100 parts of mercury combine at the ordinary temperature with 0.09 gm. of ammonium, NH_4 ; at a lower temperature it probably combines with a larger quantity.³

Cadmium Amalgam. Cadmium easily dissolves in warm mercury, giving rise to a solid compound, Hg_6Cd_2 , which has a specific gravity of 12.615. When mercury is saturated with cadmium a silver-white compound, Hg_2Cd , crystallizing in octohedrons, is formed. This is very brittle, and is heavier than mercury, and from its property of gradually hardening it is used as a stopping for teeth.

Copper Amalgam. If copper foil be rubbed with a solution of nitrate of mercury it becomes covered with a bright lustrous coating of the metal, and if a line be drawn with this solution on a piece of brass foil and the foil bent at this place, it can easily be broken, as the mercury very soon penetrates the copper and renders it brittle. Copper amalgam is obtained by rubbing a copper rod with the nitrate solution and then allowing it to

¹ Gilbert's *Ann.* vi. 260.

² Gehlen, *Neu. Allg. Journ. Chem.* v. 482.

³ *Ann. Chem. Pharm.* vi. 346.

remain in contact with mercury under warm water. All the copper amalgams which contain from 25 to 33 per cent. of copper, when heated to 100° become plastic when rubbed in a mortar. After from ten to twelve hours the amalgam loses its plasticity and assumes a granular crystalline structure and is hard enough to engrave upon tin. Its density is the same in the soft and hard states and, therefore, it does not expand in hardening, and thus fills cavities when hard into which it has been pressed in the soft state. This amalgam is used for stopping teeth, but the copper which it contains renders it objectionable on account of its tendency to blacken. It is also used for sealing bottles, glass tubes, &c., when other plastic substances such as cork cannot be used, as well as for taking impressions of engraved metal work.

Silver Amalgam occurs as a mineral at Moschellandsberg, in the Palatinate, and crystallizes in the regular system. It is artificially prepared as the silver-tree (*arbor Dianæ*) by pouring mercury into a solution of silver nitrate. The composition of the product thus deposited as well as that of the natural amalgam varies considerably. When silver amalgam is heated to 440° the compound Hg_9Ag_3 remains (De Souza).

MERCURY AND OXYGEN.

232 These elements form two compounds :

Mercurous oxide Hg_2O .

Mercuric oxide HgO .

Mercurous Oxide, Hg_2O . This compound, also called suboxide or grey oxide of mercury, is easily obtained by the action of caustic alkalies on a mercurous salt. It is a blackish-brown powder, which by the action of light and a moderate temperature, as well as when brought in contact with different saline solutions, is decomposed into the metal and the monoxide.

Mercuric Oxide or Mercury Monoxide, HgO ; commonly termed *Red Oxide of Mercury, or Red Precipitate.* This compound was known to Geber, who obtained it by heating mercury in the air for a long time. It was afterwards known by the name of *mercurius precipitatus per se*. The same compound is formed when a solution of mercury in aqua fortis is evaporated, and

the residue heated; the compound thus prepared was called by Raymond Lully *mercurius præcipitatus ruber*.

When mercury is exposed in a glass flask with a long neck for several weeks to a temperature somewhat below its boiling point, small red crystals of the oxide appear on the surface, and this product, which has a dark-red colour and is highly crystalline, increases gradually in quantity. Mercury oxide is prepared on the large scale by heating an intimate mixture of mercury and mercuric nitrate until no further red fumes are given off: in this way it is obtained in the form of bright, brick-red crystalline tablets, which have specific gravity at 4° of 11.136 (Joule and Playfair). If a solution of a mercuric salt is precipitated by caustic soda, the oxide is obtained in the form of an orange-yellow amorphous powder, which becomes denser when dried and gently heated.

Mercuric oxide is a powerful poison, it possesses an unpleasant metallic taste and an alkaline reaction, and is slightly soluble in water. When heated it first changes to a dark cinnabar-red colour, and afterwards assumes a black tint, but on cooling it resumes its original appearance. At a red-heat it decomposes into its elementary constituents, and on cooling these partially recombine. The metallic mercury which is thus formed does not possess perfect fluidity, but attains its usual mobile character on treatment with dilute nitric acid.

When the oxide is heated with sulphur explosions occur, and it is also decomposed when brought in contact with fused sodium, with evolution of light and heat.

Mercuric oxide is used in medicine, and is valuable for various purposes in chemical analysis.

SALTS OF MERCURY.

233 Mercury forms two series of salts corresponding to the two oxides; these are termed the *mercurous salts* and the *mercuric salts*.

Therapeutic Uses of Mercury and its Compounds. Liquid mercury appears to be destitute of poisonous properties, many instances having occurred in which it has been swallowed without any evil effects following. In a finely divided state, and in the state of vapour, however, metallic mercury acts as a poison, and its salts are poisonous.

In some respects the poisonous action of mercury compounds resembles that of the salts of other heavy metals, but they also act on the animal economy in a special manner, rendering them of great therapeutical value. Metallic mercury is employed, in a very finely divided state, both internally and externally. It acts on the one hand upon the glandular secretions, especially upon the salivary glands, whilst on the other it affects the nervous system. Taken continuously, it produces salivation, ulcers of the mucous membrane of the mouth, and paralysis. Mercury and certain of its compounds are employed both for local and general inflammation, and is especially valuable in cases of syphilis. Of the salts of mercury, the two chlorides, calomel, HgCl_2 , and corrosive sublimate, HgCl_2 , are most generally employed. Calomel does not appear to undergo any change in the stomach, but seems to be altered in the bile secretion, by which it is taken up into the system. In large doses it acts as a poison; in smaller doses (from 0.1 to 0.4 gm.) as a purgative, and in small doses, especially when continued, it appears to act as the metal does. Corrosive sublimate is a powerful caustic poison, producing vomiting, colic, diarrhoea, and great weakness. It is used in very small doses in cases of syphilis, as it does not so readily produce salivation as the other mercurial preparations.

Mercury is not a cumulative poison, as the larger portion is quickly excreted from the body soon after it has been taken, and may be found in the excrements as well as in saliva or pus. It is, however, difficult to remove the last traces from the system, and chronic mercurial poisoning is common with those who habitually work with the metal, such as manufacturers of mirrors, barometers, &c. The poisonous effects of mercury were known to Dioscorides and Pliny, and it appears that even in those days it was employed as a medicine. From that period up to the fifteenth century, mercury was but sparingly used in medicine, and then for external purposes only. Basil Valentine was the first to employ the mercurial salts internally (*see* mercuric nitrate). Even at that time the outward use of mercurial compounds was discountenanced by the then prevailing schools of medicine, and at the beginning of the sixteenth century the few physicians who had dared to employ mercurial ointment were vigorously assailed. The employment of mercurial preparations was, however, soon afterwards introduced by Paracelsus, and by degrees became common.

MERCUROUS SALTS.

234 *Mercurous Chloride*, Hg_2Cl_2 ; commonly known as *calomel*. Calomel occurs as a mineral termed horn-quicksilver, and found at Moschellandsberg, Idria, and Almaden and other places, and crystallizing in rhombic prisms. The artificial substance has been known for a long time, and it appears to have been used in the sixteenth century as a medicine, known by the name of *Draco mitigatus*, *Manna metallorum*, *Aquila alba*, or *Mercurius dulcis*. It afterwards received the name calomel, which it now bears, from *καλομελας*, a fine black colour, because it turns black when acted upon by an alkali.

Mercurous chloride is formed by the direct union of its elements, and also by the action of hydrochloric acid or common salt solution on a dilute solution of mercurous nitrate. In order to prevent a basic nitrate being carried down with the insoluble chloride, an excess of hydrochloric acid or salt solution must be added, and the liquid must be warmed with the precipitate for some time. In this way it is obtained in the form of a yellowish-white impalpable powder.

Calomel is commonly prepared by sublimation. For this purpose an intimate mixture of mercuric chloride (corrosive sublimate) and mercury in the right proportions is heated. Another, and now nearly obsolete process, is to rub up dry mercuric sulphate in a mortar with as much mercury as it already contains, and an equal quantity of common salt, until the globules disappear and a uniform mixture is produced. This is then sublimed, the vapour of calomel being carried into an atmosphere of steam or into a chamber containing air, where it is condensed into a finely-divided form, and thus the labour of powdering it is avoided. The following decomposition occurs:—



The powder thus obtained is well washed to free it from any traces of corrosive sublimate which it may contain, and dried ready for use.

Calomel is tasteless and insoluble in water, and has a specific gravity of 6.56. It evaporates at a red heat without fusion, yielding a colourless vapour, whose specific gravity is 8.21

(Deville and Troost); this corresponds to a vapour density of 117.59, whereas the theoretical density corresponding to the formula Hg_2Cl_2 is 235.17. Hence we may conclude that calomel is decomposed on vaporization into metal and mercuric chloride, and that these bodies unite again when the vapour is cooled. Indeed, Erlenmeyer¹ has observed that the calomel thus sublimed always contains mercuric chloride and small particles of metallic mercury, and Debray² has found that when the vapour is heated in a platinum vessel to a temperature of 440° , and a gilt silver tube, through which cold water is allowed to flow, introduced into it for a few seconds, a grey film is deposited upon the cold surface. This consists of calomel interspersed with finely divided globules of mercury. Mercurous chloride is decomposed on heating with concentrated sulphuric acid; caustic soda decomposes it into mercurous oxide, whilst on boiling with hydrochloric acid it yields mercury and mercuric chloride.

Calomel is largely used in medicine. Precipitated calomel is more active in its medicinal properties than the substance prepared by sublimation, owing to its state of finer division. In certain cases abnormal poisonous effects have been produced by calomel, which have probably been caused by the material containing basic mercurous nitrate.

Mercurous Bromide, Hg_2Br_2 , possesses great similarity to calomel, and is obtained as a heavy precipitate by adding hydrobromic acid or potassium bromide to mercurous nitrate. It may likewise be prepared in the form of glittering needles by the subliming a mixture of mercuric bromide and mercury. Mercurous bromide volatilizes at a red-heat, yielding a vapour whose specific gravity is 10.14 (Mitscherlich).

Mercurous Iodide, Hg_2I_2 , is formed when iodine or mercuric iodide is rubbed up, in the right proportion, with mercury, a small quantity of alcohol being added. It may also be obtained by precipitating the solution of mercurous nitrate with potassium iodide. It is a greenish coloured powder, slightly soluble in water, which decomposes gradually on standing into mercuric iodide and metallic mercury. The same change takes place quickly at a high temperature. According to Yvon³ this compound is obtained in the form of yellow crystals by heating together iodine and mercury in the proportion of equal molecules, in a retort placed upon a sand-bath, to a temperature not

¹ *Ann. Chem. Pharm.* cxxxi. 124.

² *Compt. Rend.* lxxxiii. 330.

³ *Compt. Rend.* lxxvi. 1607.

exceeding 250° . The crystals are rhombic, and when heated to 70° they become red, whilst at 220° they assume a darker red colour. Heated somewhat above this point they melt, forming a blackish liquid boiling at 310° . The crystals begin to sublime, however, at 190° , and are decomposed when they are quickly heated. Mercurous iodide in the form of powder is used in medicine.

Mercurous Fluoride, Hg_2F_2 , is a salt soluble in water, being obtained in the form of yellow crystals.

Mercurous Chlorate, $Hg_2(ClO_3)_2$, is formed by dissolving freshly precipitated mercurous oxide in chloric acid, and evaporating the solution over sulphuric acid. It is then deposited in fine rhombic prisms, which when heated to 250° decompose into mercuric chloride, mercuric oxide, and oxygen, and when heated with combustible matter deflagrate violently.

Mercurous Perchlorate, $Hg_2(ClO_4)_2 + 6H_2O$, is obtained in the form of deliquescent needles by dissolving mercurous oxide in aqueous perchloric acid and evaporating the solution.

Mercurous Sulphate, Hg_2SO_4 , is formed by heating concentrated sulphuric acid with an excess of mercury, or by precipitating mercurous nitrate with sulphuric acid. It is a black crystalline powder which when gently heated melts, and on cooling solidifies to a crystalline mass. It is precipitated almost completely by sulphuric acid from its solution in nitric acid. It is easily soluble in hot sulphuric acid; part of it separates out on cooling, and the remainder is precipitated on the addition of water.

Mercurous Nitrate, $Hg_2(NO_3)_2$, is formed by the action of dilute nitric acid in the cold on mercury. Hot nitric acid, on the other hand, especially if an excess of acid be employed, forms with metallic mercury, mercuric nitrate. Bergmann was the first to point out the difference between the two solutions thus obtained, the explanation, according to the then prevalent views, being that the solution of the metal in cold nitric acid contained less phlogiston than that in the hot acid. At a later period the same fact was explained by stating that in the former the mercury was less strongly oxidized than in the latter case.

Mercurous nitrate crystallizes in monoclinic tables or prisms, containing two molecules of water of crystallization, which it loses on exposure to dry air or over sulphuric acid. The salt dissolves in a small quantity of warm water; on the addition of more water a basic salt is formed. It is easily soluble in dilute

nitric acid, and this solution brought on to the skin colours it, first purple and then of a black tint. By the continued action of nitric acid upon an excess of mercury the basic double salt, $\text{Hg}_2 \left\{ \begin{array}{l} \text{NO}_3 \\ \text{NO}_3 \end{array} \right. + \text{Hg}_2 \left\{ \begin{array}{l} \text{OH} \\ \text{NO}_3 \end{array} \right.$, is formed together with the normal nitrate. This basic salt crystallizes in long, thin, rhombic prisms, and if this salt or the normal salt be boiled for some time with mercury, the water being replaced as it evaporates, large, colourless, hard, glistening triclinic prisms, having the formula $\text{Hg}_2 \left\{ \begin{array}{l} \text{NO}_3 \\ \text{NO}_3 \end{array} \right. + 4 \text{Hg}_2 \left\{ \begin{array}{l} \text{OH} \\ \text{NO}_3 \end{array} \right.$, are deposited when the solution is allowed to cool. By the protracted action of cold water on the different mercurous nitrates a yellowish crystalline salt, having the composition $\text{Hg}_2 \left\{ \begin{array}{l} \text{OH} \\ \text{NO}_3 \end{array} \right.$, is formed; this is decomposed on boiling with water into mercury and mercuric nitrate.

Mercurous Carbonate, Hg_2CO_3 , is obtained by precipitating the nitrate with hydrogen potassium carbonate. In order to remove a quantity of basic nitrate which is thrown down at the same time, the potassium carbonate is added in excess, and the solution allowed to stand for some days. Mercurous carbonate is a yellow powder which decomposes at 130° into carbon dioxide, mercury, and mercuric oxide (Lefort).

MERCURIC SALTS.

235 *Mercuric Chloride*, HgCl_2 . This salt is obtained when mercury is heated in chlorine. It was first obtained by Geber according to the following receipt: "Argentum vivum sic sublima. Sume de eo libram unam, vitrioli rubificati libras duas, aluminis rochae calcinati libram unam, et salis communis libram semis et salis petrae quartem partem, et incorporatum sublima, et college album, densum, clarum et ponderosum, quod circa vasis sponditia inventum fuerit, et serva, ut tibi de aliis scripimus. Sed si in prima sublimatione inventum fuerit turbidum vel immundum, quod tibi accidere poterit propter tuam negligentiam, illud cum eisdem fecibus noveris iterum sublimare, et serva." At a later date a somewhat similar method of preparation was employed on the large scale, and the product was termed *Corrosive sublimate* or *Mercurius sublimatus*

corrosivus. For this purpose an intimate mixture of 3 parts of mercury, 2 of common salt, 2 of saltpetre, and 4 of calcined ferrous sulphate was heated :—

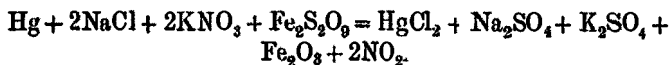

The nitrogen peroxide which was given off was condensed in water, and the acid obtained employed for the preparation of mercuric oxide. In the time of Basil Valentine, corrosive sublimate was a well-known commercial article. He was aware that hydrochloric acid is one of its component parts, and knew that metallic iron precipitated mercury from its solution. He says : "Recipe mercurii sublimati, such as can be bought at the druggists, and has been sublimed with vitriol and salt ; for the ζ takes up in the sublimation the quintam essentiam salis. Then rub down the mercurium sublimatum very finely, lay it in the cellar in a thin layer on an iron plate, let it lie for some days and nights, when a fluid will be seen to flow from it, and the ζ is revived."

From its strongly corrosive properties, mercuric chloride was also termed *Draco*, and as it is capable of destroying the metallic lustre of several metals, it was called *mors* or *mallens metallorum*.

The process which is now employed for the manufacture of corrosive sublimate, namely, that of subliming a mixture of mercuric sulphate and common salt, was first suggested by Kunkel, who in the year 1760 described this process in his *Laboratorium Chymicum* as follows :—"The best *mercurius sublimatus* for use in chemistry and such as pleases me, is when I take an oleum vitrioli, which has been highly freed from all its phlegm, with merc. viv. ana, or if it has not been rectified so well, merc. one part and oleum one and a half parts, and distil off so much oleum until all the merc. is coagulated. This white Præcipitat sublimed with Sal communis ana gives a fine corrosive sublimate."

Mercuric chloride is obtained commercially by heating a mixture of equal parts of dry common salt and mercuric sulphate. As the latter salt can only with difficulty be got free from mercurous salt, one-tenth of its weight of manganese dioxide is added to the mixture in order to prevent formation of calomel. The sublimation is carried on in large, flat, long-necked glass balloons, which are first placed in a sand-bath up to

their necks, and gently heated in order to drive off all moisture. So much of the sand is then removed that only the lower half of the balloon is surrounded by sand, and then this is heated more strongly until the whole of the chloride is sublimed. On cooling, the balloon is broken and the cake of sublimate removed.

Mercuric chloride is deposited from solution in colourless rhombic crystals. The commercial article is usually in the form of a semi-transparent crystalline crust. According to the experiments of Poggiale, 100 parts of water dissolve the following:—

At	10°	20°	50°	80°	100°
HgCl ₂	6·57	7·39	11·34	24·3	53·96.

Mercuric chloride dissolves in about three parts of alcohol and four parts of ether, so that when this liquid is shaken up with the aqueous solution, the greater part of the salt is removed from the water. It crystallizes from its solution in needles or in pointed four-sided prisms. It also dissolves without decomposition in concentrated sulphuric and nitric acids. Its specific gravity is 5·403 (Karsten). When heated it melts and volatilizes more readily than calomel; the specific gravity of its vapour is 9·8 (Mitscherlich), corresponding to a vapour density of 135·27. Corrosive sublimate possesses a sharp metallic taste, and is a violent poison, and it is largely used, both externally and internally, in medicine, especially in syphilis. It is also used as an anti-putrescent for anatomical preparations, and in dressing furs and skins.

236 Mercuric chloride has the power of forming crystallizable compounds with a number of other chlorides, especially with the chlorides of the alkali-metals, giving rise to the following double chlorides:—

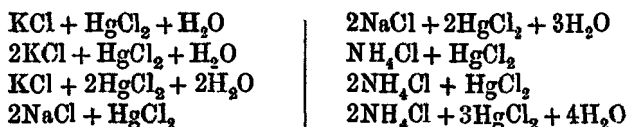

The fact that these salts dissolve in water more easily than mercuric chloride has long been known. The iatro-chemists prepared one of them by dissolving equal parts of corrosive sublimate and sal-ammoniac, and crystallizing the solution. It was termed by them *Alembroth*.

Mercuric chloride dissolves in hydrochloric acid of specific gravity 1.158, when slightly warmed. On cooling, a crystalline mass of the compound $\text{HgCl}_2 + \text{HCl}$ is deposited, whilst on strongly heating the solution the compound $2\text{HgCl}_2 + \text{HCl}$ is formed. Both lose hydrochloric acid on exposure to the air (John Davy).¹

When mercuric chloride is heated from 200° to 220° with phosphorus pentachloride, the compound $3\text{HgCl}_2 \cdot 2\text{PCl}_5$ sublimes in fine glistening needles, which melt readily. The same compound is formed when calomel is heated with phosphorus pentachloride :

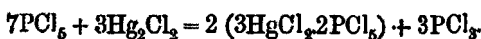

Mercuric chloride also forms a series of basic salts or *oxychlorides*. If mercuric oxide be boiled with a solution of corrosive sublimate, and the liquid filtered, a mixture of several basic chlorides separates out at a temperature above 60° . The solution poured off from this yields, on further cooling, yellow monoclinic needles, having the composition $2\text{HgCl}_2 + \text{HgO}$. This compound is insoluble in alcohol, and may thus be separated from corrosive sublimate. If one volume of a cold saturated solution of acid potassium carbonate be added to four volumes of cold sublimate solution, a yellow precipitate is first obtained, and this, on standing in the liquid, attains a red, purple, or violet tint, sometimes being amorphous and sometimes crystalline. This compound has the composition $\text{HgCl}_2 + 2\text{HgO}$, and yields the yellow oxide on treatment with potash. The same compound is formed when the red oxide is boiled with an excess of sublimate solution, in the form of a pitch-black crystalline precipitate, which on treatment with potash yields the red oxide. When equal volumes of a cold saturated solution of sublimate, and of hydrogen potassium carbonate are mixed, the oxychloride $\text{HgCl}_2 + 3\text{HgO}$, separates out in glistening, golden-yellow scales. In addition to these, several other oxychlorides are known containing a larger amount of oxygen.

Mercuric Bromide, HgBr_2 . Mercury combines with bromine with evolution of heat, and the oxide dissolves in hot aqueous hydrobromic acid. The bromide crystallizes from aqueous solution in glistening scales, and from alcoholic solution in rhombic needles or prisms, which can easily be sublimed.

Mercuric Iodide, HgI_2 , is formed when the two elementary

¹ *Phil. Trans.* 1822, p. 357.

constituents are rubbed together in a mortar with a small quantity of alcohol. It forms a scarlet crystalline powder. It is also precipitated when a solution of potassium iodide is added to one of corrosive sublimate. In this case, however, the precipitate which first forms has a pale yellow colour, but soon becomes scarlet; it is easily soluble in an excess of either liquid. Mercuric iodide crystallizes in quadratic prisms and pyramids, from solution in hot, moderately concentrated solution of iodide of potassium, in boiling alcohol, or in hot nitric acid.

Mercuric iodide is dimorphous, for on gently heating the red modification to a temperature of 150° , a remarkable change occurs, the mass becoming yellow. This change also takes place when the red crystals are melted or sublimed, yellow rhombic prisms being formed. These readily pass into the red modification when touched or rubbed with a hard body, and even spontaneously, heat in this latter case being evolved, and the red crystals retaining the form of the yellow. The specific gravity of the vapour of mercuric iodide is 15.6 to 16.2, according to Mitscherlich; this corresponds to a vapour density of 225.9. It is very slightly soluble in water, but dissolves in many aqueous acids, ammoniacal salts, salts of mercury, and soluble iodides, with which it forms soluble double compounds.

When a cold solution of corrosive sublimate and then water is added to an alcoholic solution of potassium tri-iodide (KI_3) heated to 50° , a brown crystalline precipitate is obtained of *mercury periodide*, HgI_6 . If both solutions be mixed together hot, and allowed to cool slowly, rhombic tables of mercury periodide are obtained mixed with the yellow and red iodide. Mercury periodide possesses in a high degree the peculiar optical properties of tourmaline (vol. i. p. 747), and readily loses iodine.

Mercuric Fluoride, $HgF_2 + 2H_2O$, is formed by the action of excess of hydrofluoric acid upon the oxide. It is a white crystalline mass which decomposes at 50° , with formation of the yellow oxyfluoride, $HgF(OH)$, which is also obtained when an excess of mercuric oxide is treated with hydrofluoric acid. On slow evaporation it separates in dark-yellow crystals.

Mercuric Chlorate, $Hg(ClO_3)_2 + H_2O$, is formed when mercuric oxide is dissolved in warm chloric acid. The chlorate crystallizes on cooling in small rhombic pyramids. When rubbed together with combustible substances it inflames without explosion, and, on heating, it is resolved into calomel, corrosive sublimate, and oxygen.

237 *Mercuric Sulphate*, HgSO_4 . This salt was known in the fourteenth century, and is obtained by heating mercury with oil vitriol. In order to prepare a product free from mercurous salt, the mercury must be heated with 1.5 times its weight of sulphuric acid, and evaporated to dryness. In this way a white opaque mass is obtained, which crystallizes from an excess of sulphuric acid in small stellated plates, having a silvery lustre. When gently warmed it becomes yellow and afterwards red-coloured, and decomposes when strongly heated, into mercury, oxygen, sulphur dioxide, and mercurous sulphate. Boiling water decomposes it into the basic salt, Hg_3SO_6 , a heavy lemon-coloured powder which on heating becomes of a red colour. It dissolves in 2,000 parts of cold, and 600 parts of boiling, water. This basic compound was described by Basil Valentine, and was used by the iatro-chemists under the name of *turpetum minerale*.

Mercuric Nitrate, $\text{Hg}(\text{NO}_3)_2$. Basil Valentine, who classed this salt amongst the vitriols, describes its preparation as follows:—

“Vitriolum mercurii is easily made with an *aqua fort* distilled from saltpetre, and alum *ana*; if it is dissolved in it, crystals like a vitriol shoot out; these are then ablued and purified with *spiritus vini*, which previously has been rectified with *sal tartari*; thus it is made into a sweet oil. This is a noble medicine *ad tuem gallicam*, it cures all sores, consumptions, disuries, gouts, and drives out many other diseases from the human body.”

In order to prepare this salt, mercury is boiled with nitric acid until a portion of the liquid no longer gives a precipitate with common salt. On evaporating the solution over sulphuric acid large crystals, $2\text{Hg}(\text{NO}_3)_2 + \text{H}_2\text{O}$, separate out. The same salt, which is very deliquescent, is obtained as a crystalline magma, by adding strong nitric acid to the concentrated solution. The mother-liquor from the large crystals is a thick liquid which has the constant composition $\text{Hg}(\text{NO}_3)_2 + 2\text{H}_2\text{O}$. This solution possesses the power, first noticed by Libavius, of colouring the skin a dark-red tint. On evaporating the solution, a basic salt, $2\text{Hg}(\text{NO}_3)\text{OH} + \text{H}_2\text{O}$, separates out in long transparent prisma which possess a metallic, but not an acid taste. On washing these with water different more basic salts are formed, and at last mercury oxide remains behind.

The Phosphates of Mercury are white heavy precipitates.

Mercury does not form any *borates*, nor are *silicates* of mercury known.

238 *Carbonates of Mercury.* Only basic mercury carbonates are known. If a solution of mercuric nitrate be poured into an excess of potassium bicarbonate solution, a dark brown precipitate of $\text{HgCO}_3 + 2\text{HgO}$ is formed, and if a solution of caustic potash or caustic soda be employed, an amorphous brown precipitate or $\text{HgCO}_3 + 3\text{HgO}$ is formed. The constitution of these salts can be represented by the following graphic formulæ:—

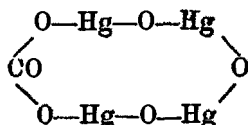
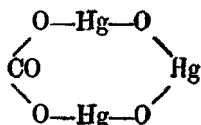

Mercuric Cyanide, $\text{Hg}(\text{CN})_2$. This compound was discovered by Scheele, who obtained it by boiling Prussian blue with mercuric oxide and water. It is also formed by dissolving mercuric oxide in dilute hydrocyanic acid, or by boiling one part of yellow prussiate of potash with two parts of mercuric sulphate and eight parts of water.

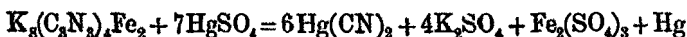

Mercuric cyanide dissolves in 8 parts of cold water and crystallizes from the hot aqueous solution in white needles or transparent quadratic prisms which are insoluble in absolute alcohol. Its aqueous solution readily dissolves mercuric oxide, and on evaporating the alkaline solution thus obtained, small needles of an oxycyanide, $\text{Hg}_2\text{O}(\text{CN})_2 = \text{CN—Hg—O—Hg—CN}$, are formed. Mercuric cyanide is decomposed by hydrochloric, hydrobromic and hydriodic acids, and by sulphuretted hydrogen, with liberation of hydrocyanic acid. It is not, however, decomposed by dilute sulphuric or nitric acids. It forms crystalline double compounds with many other salts.

Mercuric Cyanate $\text{Hg}(\text{OCN})_2$, and Mercuric Thiocyanate, $\text{Hg}(\text{SCN})_2$, are white crystalline precipitates. In order to prepare the latter salt a solution of ammonium thiocyanate is precipitated with excess of corrosive sublimate solution. This compound is used for the preparation of the so-called Pharaoh's serpents. The dried precipitate is rubbed up with gum-water to a thick plastic mass, and short cylinders are formed of this mixture, and these are then dried. On igniting them at the end they burn with a blue sulphur-like flame, the ash being very bulky and extending in a serpent-like form. The residue when heated yields mellone. (See vol. i. p. 677.)

MERCURY AND SULPHUR.

239 *Mercuric Sulphide* or *Cinnabar*, HgS , usually occurs in beds in slate rocks and shales, and more rarely in granite or porphyry. It is found in Idria, Almaden, in the Palatinate, in Carinthia, Transylvania, Tuscany, in the Urals and Altai, in China abundantly, and in Japan, Mexico, and Southern Peru. Extensive mines of cinnabar exist in California in the coast ranges at different points, at Clear Lake in the North to San Louis Obispo in the South, the principal mines in which region are at New Almaden and the vicinity in Santa Clara Co., about sixty miles S.S.E. of San Francisco.

Cinnabar is found in rhombohedral crystals, and also in the granular and massive states. It possesses a cochineal-red colour often inclined to brownish-red and lead-grey; its streak is scarlet, and it is sub-transparent or opaque, possesses a conchoidal fracture and its lustre is adamantine inclined to metal-like. Theophrastus mentions this mineral as *κινναβης*; the term, however, was afterwards used to designate dragons' blood. Pliny terms this latter substance *cinnabaris*, and, as has already been stated, the mineral cinnabar being frequently confounded with red-lead, was termed by him *minium*.

The artificial preparation of this compound was first described by Geber under the name of *usifur*. At the beginning of the seventeenth century, Turquet de Mayerne found that by rubbing mercury and sulphur together a black powder was obtained, and in 1689 Walter Harris showed that this compound can be obtained by intimately mixing dry sulphur and mercury. Prepared in this way it was termed *Aethiops mineral*, and was employed as a medicine, and in the year 1757, J. C. Jacobi proposed to employ for the same purpose the precipitate obtained, by adding caustic soda to a solution of a mercury salt; this was known under the name of *pulvis hypnoticus*. The mode of preparing cinnabar by the wet way was first observed by G. Schulz, in 1687; he obtained it by shaking together for some time, Boyle's volatile tincture of sulphur and metallic mercury. In 1773, Baumé showed that the black precipitate which this liquid produces in a solution of mercury is gradually converted into cinnabar. The difficulty of explaining the difference between the black and the red sulphides of mercury was increased by the fact that the

one can be converted into the other. Stahl believed that the black compound contained more sulphur than the red one; others assumed that in the latter compound the sulphur was more intimately combined than in the former, or that both being compounds of oxide of mercury with sulphur, the cinnabar contained mercury in a higher state of oxidation. Berthollet, on the other hand, considered cinnabar as mercury sulphide whilst he regarded the black modification as a compound of mercury with sulphuretted hydrogen. It was not until 1833 that the identity in composition of both these substances was ascertained by Fuchs,¹ and the difference between them explained by the fact that the black compound is amorphous whilst the red is crystalline.

In order to prepare cinnabar in the dry way, according to the Dutch process, mercury is added to an excess of fused sulphur and then the cold broken mass is brought into earthenware pots which are heated in a sand-bath until the excess of sulphur is driven off. The crucible is then covered with an iron plate and the temperature raised until the cinnabar sublimes and is deposited upon the plate.

In the process of manufacturing vermilion in Idria, 8 parts of sulphur and 42 parts of mercury are placed in small barrels which are caused to rotate on their axis until the contents are converted into a brown powder; this substance is then distilled in iron retorts, furnished with a head and receiver; the purest cinnabar condenses in the head of the retort whilst the portions deposited in the receiver consist of a mixture of this substance with sulphur and require redistillation. The sublimate is then very finely levigated, treated with caustic soda, and then washed with water and dried.

Vermilliou obtained in the wet way possesses a much finer colour than the sublimed vermilion, and it can be prepared in a variety of ways. According to Brunner's² process 100 parts of mercury and 38 parts of flowers of sulphur are rubbed together for some hours and then the mass mixed with 25 parts of potash dissolved in 150 parts of water at 45°. The mixture is then heated, the quantity of water being kept constant for about eight hours. After this time the mass begins to exhibit a red colour, and when the right tint has been attained the mass is quickly washed with water, as by the further action

¹ *Schweigg. Journ.* lxxvii.

² *Pogg. Ann.* xv. 503.

of potash the vermilion becomes brown. In another process described by Firmenich,¹ 5 kilos of mercury mixed with 2 kilos of sulphur and 4.5 liters of a solution of potassium pentasulphide are heated in a water-bath, the potassium pentasulphide solution being obtained by reducing 20 parts of potassium sulphate with carbon and boiling the product with 3.5 parts of water and 15 parts of sulphur. The mixture is then poured into strong stoppered bottles and these are well shaken whilst the liquid is being heated. After the lapse of from three to four hours a brown powder is formed. The liquid is then allowed to cool to 50° and is digested at this temperature for some days until the colour of the product reaches the right shade; then it is mixed with caustic soda in order to withdraw the excess of sulphur, washed with water, and dried at 60°.

Sublimed cinnabar is often observed in distinct crystals, having the form of the natural mineral. Generally, however, it forms a fibrous mass, having a cochineal-red colour, but when powdered it has a scarlet-red tint. Its specific gravity is 8.124 (Boullay); the specific gravity of its vapour is 5.51 (Mitscherlich), from which it appears that in the gaseous condition the compound undergoes partial dissociation. Cinnabar is not attacked by hot nitric acid, but aqua-regia dissolves it easily with liberation of sulphur. It is soluble in concentrated hydriodic acid in the cold and also in the dilute acid when warmed, sulphuretted hydrogen being evolved (Kekulé). Vermilion is used as an oil- and water-colour paint, for red lithographic- and printers'-ink and for colouring sealing-wax, &c. It is sometimes adulterated with red-lead or red oxide of iron. The presence of these impurities can be readily ascertained, inasmuch as pure vermilion sublimes without leaving any residue.

Black or amorphous mercuric sulphide, which occurs as a mineral in California,² is formed, as has already been stated, when flowers of sulphur and mercury are mixed together. The excess of sulphur can be removed by carbon disulphide, and the excess of mercury by dilute nitric acid. It is likewise formed when the component elements are gently heated together, and also by gently heating cinnabar in absence of air, although by the application of a stronger heat the latter compound again sublimes. When solutions of the polysulphides of the alkali metals act upon mercury, the black sulphide is likewise

¹ *Dingl. Polyt. Journ.* clxxii. 370.

² *Moore, Journ. Prac. Chem.* [2], ii. 319.

obtained, and the same compound may also be prepared by acting with an excess of sulphuretted hydrogen or sulphide of ammonium on a solution of a mercuric salt. Mercurous salts treated in this way yield a mixture of mercuric sulphide and finely-divided mercury. On passing sulphuretted hydrogen into a solution of mercuric chloride, a white precipitate is first obtained, and this becomes yellow and ultimately black on the further action of the gas. This white compound has the composition $2\text{HgS} + \text{HgCl}_2$, and on sublimation decomposes into cinnabar and corrosive sublimate. Other salts of mercury form similar compounds.

Mercuric sulphide also combines with the sulphides of the alkali metals; thus, for instance, if a solution of mercuric chloride be treated with a solution of potassium sulphide containing some free alkali, a clear solution is obtained and, on evaporation, very slender silky needles of the compound $\text{HgS} + \text{K}_2\text{S} + 5\text{H}_2\text{O}$ are deposited. It is a very unstable compound, and on washing is resolved into its constituents. It was first obtained by Brunner, in the preparation of vermilion according to his method. The conversion of the black amorphous sulphide into vermilion, probably depends upon the formation of this body.

Mercurous Sulphide does not exist, a mixture of metallic mercury and mercuric sulphide being produced in cases in which its formation might have been expected.

MERCURY AND NITROGEN.

240 *Mercury Nitride* or *Trimercuric-diamine*, N_2Hg_3 . This compound may be considered as derived from a double molecule of ammonia, N_2H_6 , by the substitution of three atoms of dyad mercury in the place of six atoms of hydrogen. For its preparation, ammonia gas is passed over dry precipitated mercuric oxide, first in the cold and afterwards at a temperature of 130° until no further formation of water occurs: ¹

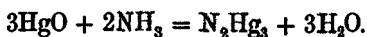

The dark-brown powder which is thus obtained is treated with dilute nitric acid in the cold in order to extract any mercury or mercuric oxide. In the dry state trimercuric-diamine explodes

¹ Plantamour, *Ann. Chem. Pharm.* xl. 115.

with great violence on heating, on friction, on percussion, or in contact with strong sulphuric acid. Alkalis decompose it, ammonia being evolved.

MERCUROUS-AMMONIUM COMPOUNDS.

241 *Mercurous-ammonium Chloride* $(\text{NH}_3)_2\text{Hg}_2\text{Cl}_2$. Precipitated calomel absorbs dry ammonia, forming a black powder, which on heating, or on exposure to the air, decomposes into mercurous chloride and ammonia.

Dimercurous-ammonium Chloride, $\text{NH}_2\text{Hg}_2\text{Cl}$, is a black powder which is obtained by treating calomel with aqueous ammonia :



It is permanent in the air, and is decomposed by hydrochloric acid gas according to the following equation :

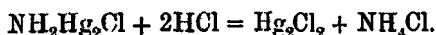

When a dilute solution of mercurous nitrate containing the smallest possible quantity of free nitric acid is precipitated with an insufficient quantity of dilute ammonia, a black precipitate, known as *Mercurius solubilis Hahnemanni*, is formed. From the analysis of C. G. Mitscherlich, it appears to possess the formula $2(\text{NH}\text{Hg}_2)\text{NO}_3, 2\text{H}_2\text{O}$. The composition of the body varies according to the method employed in its preparation, and it is, therefore, probably a mixture of several compounds. It is decomposed on exposure to light into mercury, basic mercurous nitrate, and ammonia.

MERCURIC-AMMONIUM COMPOUNDS.

242 *Dimercuricammonium Oxide*, $(\text{NH}\text{Hg}_2)_2\text{O}$. When mercuric oxide is gently warmed with pure dilute ammonia, a pale yellow powder having the composition $\text{NH}\text{Hg}_2\text{OH} + 2\text{H}_2\text{O}$ is obtained, which deflagrates without explosion on rubbing, or when thrown on to hot charcoal. Heated in a current of dry ammonia to 100° , it loses its water. The anhydrous compound is also formed by the action of dry liquid ammonia on mercuric oxide. It is a dark-brown powder, which on heating or even on

trituration, explodes very violently. Dry hydrochloric acid gas decomposes it into mercuric chloride and water. $+ 4 H^3$

Dimercuricammonium Chloride, NHg_2Cl , is formed by the action of alcoholic hydrochloric acid on the foregoing compound. It is a yellow powder which, when heated to 300° , is suddenly resolved into calomel, mercury, and nitrogen.

Mercuricammonium Chloride, NHg_2Cl . This compound is known as *infusible white precipitate*. It is formed when a solution of corrosive sublimate is precipitated by ammonia. When first precipitated, it is a bulky white power, and it possesses an earthy metallic taste (Fourcroy). Its production is represented as follows :



It decomposes below a red-heat without fusion, forming calomel, ammonia, and nitrogen :



On washing with cold water it is converted into hydrated dimercuricammonium chloride. If it be mixed with iodine and alcohol poured on it, mercuric iodide is first formed and then a violent explosion occurs. The mixture also deflagrates in the dry state after some time.

Mercuricdiammonium Chloride, $(NH_3)_2HgCl_2$. This compound, known as *fusible white precipitate*, was first prepared by Raymond Lully, by precipitating mercuric nitrate with sal-ammoniac and salt of tartar. He was acquainted with its property of fusing when heated. At a later time this body was confounded not only with the foregoing compound, prepared first by Lemery, but also with calomel prepared by the wet process. Kuukel, although he gave both to this last preparation and to fusible white precipitate the name of *lac mercurii*, was aware of their difference. He says, "Whether these two have the same effect in medicine, I leave to the physicians and surgeons; *in examine chymico* they are very different." Wöhler, in 1838, pointed out the difference between the fusible and infusible precipitate.

Fusible white precipitate is obtained either by adding a solution of corrosive sublimate to a boiling aqueous mixture of sal-ammoniac and ammonia as long as the precipitate which is formed dissolves, or by boiling the infusible white precipitate with a solution of sal-ammoniac. Small regular dodecahedrons

¹ Weyl, *Pogg. Ann.* cxxi. 606; cxxx. 539.

or crystalline crusts are deposited on cooling, and these on heating fuse, losing nitrogen and ammonia, and a mixture of calomel, corrosive sublimate, and sal-ammoniac sublimes.

In addition to the above-mentioned mercuric-ammonium compounds, many others have been prepared. They may be considered to be derived from ammonium salts, either by complete or partial substitution of their hydrogen by dyad mercury.

Of these must be mentioned :

Oxydimercuricammonium Iodide, $\text{NH}_2\text{Hg}_2\text{OI}$, which is formed by the action of an excess of ammonia on mercuric iodide, and also when ammonia is passed at a temperature of 180° over the basic oxy-iodide of mercury, $\text{Hg}_2\text{O}_3\text{I}_2$:

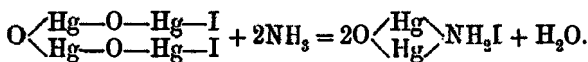

The same compound is easily obtained by adding ammonia to a solution of mercuric potassium iodide, containing an excess of potash, and hence this liquid, known as Nessler's solution, (vol. i. p. 252,) is employed as a very delicate re-agent for the detection of ammonia. Oxydimercuricammonium iodide is a brown powder which often exhibits a reddish-purple colour, and, on heating in absence of air, fuses to a brown liquid, and when more strongly heated, decomposes with emission of light, into water, mercuric iodide, ammonia, and nitrogen.

MERCURY AND PHOSPHORUS.

243 *Mercuric Phosphide* is obtained as a black powder, together with mercuric phosphate, by heating mercuric oxide and phosphorus together in water. If a current of phosphorus hydride be passed over gently-heated mercuric chloride, an orange yellow sublimate of mercuric phosphide is obtained which decomposes on heating into its elements (H. Rose).

Dimercurphosphonium-Mercuric Chloride, $2(\text{PHg}_2\text{Cl.HgCl}_2) + 3\text{H}_2\text{O}$, is formed by the action of phosphorus hydride upon a solution of corrosive sublimate :

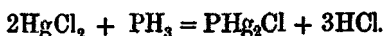

It is decomposed on heating, and on boiling with water :

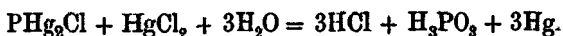

Other mercurphosphonium compounds having a similar constitution have been prepared.

DETECTION AND ESTIMATION OF MERCURY.

244 Bunsen's flame-reaction may be conveniently employed in order to detect the presence of mercury in a solid body. For this purpose the substance is mixed with a small quantity of anhydrous sodium carbonate and nitre, and the mixture is heated in a tube held in the flame by means of a platinum wire wound round it, the mouth of the tube being placed directly under a small porcelain basin filled with cold water. The mercury is then volatilized, and deposits on the cool lower surface of the porcelain basin in the form of a grey film. This is wiped off with a small piece of filter paper, when the minute globules of liquid metal are rubbed together and a larger globule is obtained. If a large quantity of mercury be present, globules are at once formed on the cold basin.

When a liquid has to be tested for mercury, it is in the first place acidified with hydrochloric acid. If this produces a white precipitate a mercurous salt may be present together with silver, lead and thallium. The two last metals may be removed by boiling the precipitate with water. The residue is then treated with ammonia, in which the chloride of silver is soluble. If a black powder remains mercury is present, and its presence can be confirmed by the flame reaction just described. The filtrate from the first precipitate, or the solution in which the hydrochloric acid gives no precipitate, is saturated with a current of sulphuretted hydrogen gas. If mercury be present a white precipitate will first be formed, this rapidly changes colour, becoming yellow, brownish-red, and finally black. In order to separate mercury from the other sulphides which may be present, the precipitate is first washed with hot water, then warmed with sulphide of ammonium, again washed with water, and the residue treated with hot dilute nitric acid. If a heavy black powder remains undissolved, this is treated with aqua-regia, the solution concentrated, and tin dichloride added to this solution, when calomel is precipitated, and if an excess of the precipitant be added, finely-divided metallic mercury is deposited as a black powder, which on boiling with hydrochloric acid unites to form distinct globules. The following equation represents the decomposition :

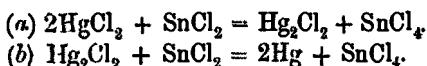

The spark-spectrum of mercury obtained by an electric discharge passing from platinum wires moistened with mercuric chloride contains several lines, of which one in the green almost coincident with a silver line, and one in the blue are especially bright. In addition to these there are two other characteristic lines close together, occurring in the greenish yellow (Lecoq de Boisbaudran).

Mercury is best determined quantitatively by precipitating the solution with sulphuretted hydrogen. The sulphide thus precipitated frequently contains free sulphur, and it is therefore warmed with hydrochloric acid, nitric acid being added drop by drop until the sulphur, which separates out, has become yellow. Then the solution is diluted with water, nearly neutralised with caustic soda, excess of potassium cyanide added, and the sulphide again thrown down with sulphuretted hydrogen; the precipitate thus obtained is quickly washed with cold water, dried at 100° and weighed. Mercury can also be determined as mercurous chloride and as the metal.

The atomic weight of mercury has been determined by Erdmann and Marchand,¹ by the analysis of pure cinnabar and pure mercuric oxide. The mean of five analyses of the sulphide was as follows:

Mercury	86·211
Sulphur	13·789
	100·000

From this the following atomic weight is calculated:

$$\frac{86\cdot211 \times 31\cdot98}{13\cdot789} = 199\cdot94$$

Five analyses of the oxide gave the following mean:

Mercury	92·597
Oxygen	7·403
	100·000

The atomic weight thus obtained is:

$$\frac{92\cdot597 \times 15\cdot96}{7\cdot403} = 199\cdot63$$

Hence the mean of the two determinations is 199·8.

¹ *Journ. Pract. Chem.* xxxi. 385.

METALS OF THE CERIUM GROUP.

Yttrium.	Didymium.
Lanthanum.	Terbium.
Cerium.	Erbium.

245 In the year 1794 Professor Gadolin of Abo in Finland discovered a new earth in the mineral, termed after him gadolinite, which had been found at Ytterby in the year 1788. This discovery was confirmed in the year 1797 by Eckeberg, who found that the compound separated by Gadolin contained, together with glucina, a new earth, to which he gave the name of yttria. In 1803 Klaproth discovered a second peculiar earth in another Swedish mineral found at Riddarhyttan, which mineral had formerly been supposed to contain tungsten, and to this, because it became dark-yellow on heating, he gave the name of ochroite. The same substance was examined simultaneously by Berzelius and Hisinger, and they considered it as the oxide of a new metal and termed it cerium, after the planet Ceres, which had been recently discovered, whilst the mineral was called cerite.

In 1819 Berzelius observed that crude yttria also contains ceria; and Mosander, in 1839, showed, in a most careful investigation, that the latter earth contained the oxide of another metal, to which he gave the name of lanthanum (*λανθάνω*, I lie hidden); and in 1841 he discovered a third new substance, to which he gave the name didymium (from *διδύμοι*, twins). The same chemist in 1843 concluded from another series of investigations that yttrium is invariably accompanied by two other metals, to which he gave the names of terbium and erbium from the terminal letters of the stem of the word Ytterby. According to the investigations of Bunsen and Bahr,¹ only one of

¹ *Ann. Chem. Pharm.* cxxxvii. 1.

the two last-named metals appears to exist, and for this they retained the name erbium, but the recent researches of Delafontaine and Marignac¹ have however shown that terbium is a distinct element.

The metals of the cerium group occur in several rare minerals found in Scandinavia, Siberia, and Greenland. They are chiefly contained as silicates, less frequently as phosphates, tantalates, titanates, and fluorides. The following analyses give the composition of some of the most important of these:—

Cerite from Bastnas (Hermann).		Orbite from Greenland (Rammelsberg).	
SiO ₂	21.35	SiO ₂	33.78
Ce ₂ O ₃	60.99	Al ₂ O ₃	14.03
La ₂ O ₃	3.51	Fe ₂ O ₃	6.36
Di ₂ O ₃	3.90	Ce ₂ O ₃	12.63
FeO	1.46	La ₂ O ₃	5.67
CaO	1.65	FeO	13.63
H ₂ O	6.31	CaO	12.12
CO ₂	0.83	H ₂ O	1.78
	100.00		100.00
Gadolinite from Ytterby (König).		Wöhlerite from Hitteroc (Jehn).	
SiO ₂	22.61	Nb ₂ O ₅	18.37
Y ₂ O ₃	34.64	YiO ₂	34.90
Ce ₂ O ₃	2.86	UO ₂	7.75
Er ₂ O ₃	2.93	Al ₂ O ₃	5.41
Di ₂ O ₃	8.38	Ce ₂ O ₃	8.43
La ₂ O ₃	3.21	Y ₂ O ₃	13.20
Fe ₂ O ₃	4.73	FeO	2.54
FeO	5.76	MgO	3.92
BeO	6.96	CaO	1.63
CaO	0.83	H ₂ O	2.87
MgO	0.15		99.02
Na ₂ O	0.38		
H ₂ O	1.93		
	99.37		

246 The separation of the metals of this group from one another, and the preparation of their pure compounds, is

¹ *Arch. S. Phys. Nat. de Genève*, 1878, 273 and 283.

extremely difficult. Of the several methods which have been proposed we shall here only mention that which Bunsen¹ employs in his spectral-analytical researches. His words are as follows:

“As the separation of these earths presents very considerable difficulties, and as the methods hitherto employed do not yield altogether satisfactory results, it appears to me to be necessary that I should say something concerning the preparation of the perfectly pure material with which the spectra hereafter described were obtained.

“Cerite from Utöe was pulverised and mixed in a Hessian crucible with concentrated sulphuric acid in quantity sufficient to fill the crucible to one-third; the excess of acid was removed by strongly heating the crucible; the powdered residue was mixed with water at 0°, care being taken that no rise of temperature should ensue; the solution was separated by filtration from the solid matter, which was again treated with sulphuric acid, &c. From the solution saturated with sulphuretted hydrogen (in order to remove arsenic, molybdenum, bismuth, copper, and lead), strongly acidified with hydrochloric acid and oxidised by chlorine, the oxalates of cerium, lanthanum, and didymium were precipitated by means of oxalic acid. The oxides, obtained by strongly heating the precipitated oxalates, were dissolved in nitric acid, and the solution was evaporated to the consistency of a syrup over the water-bath.

“By dissolving the mass after cooling in cold water, and boiling the liquid for some time with water containing 2 cubic centimeters of concentrated sulphuric acid per liter, the greater part of the cerium was precipitated as basic sulphate (three liters of the acidified water were required for 250 grams of cerite). The precipitate was washed with acidified water, dissolved in a slight excess of dilute sulphuric acid, and the solution reprecipitated by pouring into a liter of boiling water. The solution, precipitation, and washing were repeated two or three times before every impurity was removed from the precipitate. After these processes the greater part of the cerium remains in solution, so that but a few grams of the pure cerium compound are obtained from 100 grams of the mixed oxides. A pure product may be obtained from the various liquids collected during the processes by treating them as described above.

“The perfect purity of the substance thus obtained was shown

¹ *Phil. Mag.* [4], 1. 533.

by the following behaviour: The pale-yellow hydrated oxide precipitated by caustic potash from the solution of the basic sulphate, when treated with chlorine in a concentrated solution of caustic potash, yielded a deep orange-red oxidation product, without the solution (although saturated with chlorine) taking up the smallest trace of a foreign earth.

"Cerium oxide, after being strongly heated in the air, is of a pure yellowish-white colour, which changes to orange while the oxide is hot. The sulphate does not give the smallest precipitate (thorium oxide) when warmed with sodium dithionate. The oxalate is to a considerable extent soluble in ammonium oxalate solution, but is entirely reprecipitated on dilution with cold water. Small quantities obtained in this way by fractional precipitation, when converted into chlorides, showed one and the same spark-spectrum when examined, and gave no indication of the lines peculiar to lanthanum or yttrium. No appearance of the absorption spectrum of didymium or erbium could be obtained with any of the concentrated cerium solutions.

"The preparation of pure lanthanum compounds is best commenced with the liquid from which basic cerium sulphate has been for the first time precipitated by means of boiling acidified water. This liquid is boiled with natural pulverised magnesite, whereby the greater part of the dissolved cerium oxide is precipitated. After removing the precipitate, oxalic acid is added to the liquid acidified with hydrochloric acid; the precipitate which is formed is strongly heated in a porcelain crucible till the oxalic acid is decomposed; the oxides thus formed are dissolved in sulphuric acid; the solution is evaporated, diluted with water, and again boiled with magnesite. The liquid, which yet contains traces of cerium, is several times subjected to the same treatment with oxalic acid and magnesite; the oxides are at last dissolved in sulphuric acid, the acid is removed by evaporation, and the salt is heated to incipient redness. In order to obtain from this salt a lanthanum compound perfectly free from didymium, the original process of Mosander is the simplest and safest. The dehydrated sulphate is dissolved in small quantities of water at 0° to 5° ; the liquid is warmed until the lanthanum salt precipitates in the form of a soft white mass of small needles; this mass is placed in a funnel heated to 100° , and the mother liquor (which is set aside for the preparation of didymium salts) is removed by means of the air-pump. The mass dehydrated at an incipient red-heat is treated

in the same way six or eight times. A layer 0.2 millimeter thick of a concentrated solution of pure lanthanum sulphate shows no trace of the absorption-lines of didymium or erbium, nor, after conversion into chloride and testing in the spark-spectrum, any of the lines of cerium or yttrium.

"Samples of lanthanum oxalate obtained from this material by fractional precipitation exhibited, when converted into chlorides, no differences in the number, position, and relative intensity of their lines.

"Lanthanum oxalate comports itself towards ammonium oxalate in the same manner as the corresponding cerium salt; the fractional precipitates from ammonium oxalate show the same spectrum throughout. Lanthanum chloride gives no flame-spectrum; but it is characterised by a very brilliant spark-spectrum rich in lines.

"The first mother-liquor from the lanthanum sulphate is the starting-point in the preparation of pure didymium compounds. The methods hitherto put forward for the purifying of didymium compounds yield substances in which lanthanum is easily detected by the spark-spectrum. The removal of these impurities is carried out by me as follows: If didymium sulphate, prepared according to Mosander's original directions, be decomposed by oxalic acid gradually added, the oxalates of didymium and lanthanum, which are at first precipitated, are again dissolved, until a point is reached when, upon the further addition of acid and shaking, the formation of a permanent crystalline amethyst-coloured precipitate commences. This first part of the precipitate is rich in didymium; it is separated from the other part, which contains larger quantities of lanthanum.

"The precipitate is converted into neutral dehydrated didymium sulphate, which is again treated in the way just described; and this treatment is repeated until the last product does not exhibit any lanthanum-lines in the spark-spectrum."

247 The following method was employed by Bunsen and Bahr¹ for the preparation of pure yttrium and erbium compounds. Gadolinite is decomposed by heating with strong hydrochloric acid and the solution of the chlorides precipitated with oxalic acid. The mixed oxalates of yttrium, erbium, cerium, lanthanum, didymium, calcium, and magnesium, together with traces of oxalate of manganese and silica, are then converted into nitrates, and the solution treated with an excess of solid

¹ *Ann. Chem. Pharm.* cxxxvii. 1.

potassium sulphate. Double sulphates of cerium, lanthanum, and didymium with sulphate of potash are thus formed, and as these double salts are insoluble in a solution of potassium sulphate, the above three metals can thus be separated from the yttrium and erbium. These latter are then precipitated from the solution by means of oxalic acid; the oxalates converted into the oxides by ignition, and these washed with hot water in order to remove any potassium carbonate. The oxides are then again dissolved in nitric acid, re-precipitated from solution as oxalates, and again converted into oxides by ignition; these several operations being repeated until the nitric acid solution does not yield any longer the characteristic absorption-spectrum of didymium. The solution is then precipitated with ammonia, when any calcium and magnesium salts present remain in solution, the precipitate dissolved in nitric acid, and the solution of the nitrates precipitated with oxalic acid. In order to separate yttrium and erbium the oxalates are converted into the nitrates, the solution evaporated in a platinum basin until bubbles of nitrous fumes begin to come off, and then the basin quickly cooled by placing it in cold water. The bright glassy mass obtained on cooling is dissolved in such a quantity of warm water that, on boiling, no precipitate is thrown down. On slowly cooling, needles of erbium nitrate separate out containing yttrium. These are separated by decantation from the liquid, and washed with water containing three per cent. of nitric acid. The mother-liquor yields a second crop of crystals on repetition of the process, the latter portions containing however more yttrium. The salt can be purified by mixing the first and purer crops of crystals, and recrystallising, and by a repetition of these operations pure erbium nitrate can be prepared.

For the preparation of the yttrium compounds, the above mother-liquor is employed, which, together with erbium, also contains other metals of the group. The liquid is treated repeatedly with potassium sulphate until the solution does not show the didymium absorption-spectrum. The yttrium sulphate, containing erbium sulphate, is then converted into the nitrate, and this heated nearly to redness. Water dissolves basic yttrium nitrate from the residue, and by repeating this process a product is ultimately obtained which does not exhibit the absorption-spectrum of erbium.

The metals contained in cerite and gadolinite decompose water slowly at the ordinary temperature, dissolve readily in

dilute hydrochloric acid, and form with water insoluble basic sesquioxides such as Y_2O_3 and its corresponding salts YCl_3 , $Y_2(SO_4)_3$, &c.

YTTRIUM. $Y = 92.5$.

248 Berzelius obtained the metal yttrium in the form of a dark grey powder by heating the chloride with potassium. The powder assumed under the burnisher the lustre and colour of iron. It is clear from what has already been stated that this product is a mixture of yttrium and erbium.

Yttrium Oxide, Y_2O_3 , is obtained as a yellowish-white powder by igniting the oxalate or hydroxide. On ignition this emits a bright white light. It does not combine directly with water, but when an yttrium salt is precipitated with an alkali the hydroxide is thrown down as a gelatinous precipitate. Yttrium oxide dissolves slowly but completely in hydrochloric, nitric, and sulphuric acids.

SALTS OF YTTRIUM.

249 *Yttrium Chloride*, YCl_3 , formed by heating the metal in chlorine, is a white non-volatile body. When the oxide is dissolved in hydrochloric acid the hydrate $YCl_3 + 6H_2O$ is obtained on evaporation in deliquescent prisms which are soluble in alcohol but insoluble in ether. These decompose when heated alone with evolution of hydrochloric acid; but when ignited in presence of sal-ammoniac the anhydrous chloride is obtained.

The bromide and iodide are very similar to the chloride.

Yttrium Fluoride occurs together with the fluorides of cerium and calcium in the mineral yttrocerite found near Fahlun in Sweden, at Amity, Orange County, New York, in Massachusetts, and at Mount Mica in Maine. It is massive, crystalline-granular and earthy, having a glistening vitreous to pearly lustre, and colour varying from violet-blue to grey and white. Sometimes it has a reddish-brown colour.

Yttrium Sulphate, $Y_2(SO_4)_3 + 8H_2O$, forms transparent crystals, which lose their water at 115° . 100 parts of water at $15^\circ.5$ dissolve 15.2 parts of the anhydrous salt, but when the solution is warmed a portion separates out in the crystalline state.

Yttrium Nitrate, $Y(NO_3)_3 + 6H_2O$, is easily soluble in water, alcohol, and ether, forming large needles which do not effloresce in the air.

Yttrium Orthophosphate, $YPO_4 + 2H_2O$, is slightly soluble in water; the *metaphosphate*, $Y(PO_3)_3$, is an insoluble crystalline powder; and the *pyrophosphate*, $2YHP_2O_7 + 7H_2O$, is soluble in water.

Yttrium Carbonate, $Y_2(CO_3)_3 + 3H_2O$, is a heavy white powder insoluble in water.

Yttrium Sulphide, Y_2S_3 , is obtained as a grey powder by heating the oxide in the vapour of carbon disulphide. It is not soluble in water, but is decomposed by acids (Wöhler).

DETECTION AND ESTIMATION OF YTTRIUM.

250 This metal is most readily recognised by the spark spectrum of the chloride. This contains a large number of bright lines, of which two groups lying near the sodium line towards the red are especially characteristic. The reactions of the yttrium salts are very similar to those of zirconium, under which metal further details will be given.

In order to estimate yttrium quantitatively it is precipitated as the oxalate or hydroxide, and this by ignition is converted into the oxide. If potassium salts are present, the oxalate precipitate consists of yttrium potassium oxalate, and this on heating yields a mixture of yttria and potassium carbonate, which must then be dissolved in hydrochloric acid and the earth reprecipitated by ammonia.

The *atomic weight* of yttrium was determined by Bahr and Bunsen by the analysis of the sulphate to be 92.5. According to Cleve and Hoeglund¹ on the other hand it is 89.6.

LANTHANUM. La = 139.0.

251 Mosander obtained metallic lanthanum as a grey powder by heating the chloride with potassium. Hillebrand and Norton² prepared it by the electrolysis of the fused chloride, and obtained it in the form of fused globules, some of which weighed as much as six grams. Thus prepared it has a specific gravity of 6.163 and an iron grey colour; it takes a high

¹ *Bull. Soc. Chim.* [2] viii. 193.

² *Pogg. Ann.* clvi. 466.

polish, but soon tarnishes, even on exposure to dry air, attaining a steel-blue colour. The metal can be hammered out to tolerably thin foil, but cannot be drawn into wire. The finely-divided metal burns brightly when thrown into the flame. It also takes fire when thrown into chlorine gas. It burns less brightly in bromine vapour, and combines with iodine without evolution of light and heat. Cold water oxidises it slowly with formation of the hydroxide. Cold concentrated sulphuric acid does not attack it, but in dilute sulphuric acid and in hydrochloric acid it dissolves with violent evolution of hydrogen gas, and is oxidised both by concentrated and dilute nitric acid.

Lanthanum Oxide, La_2O_3 . This is obtained in the form of a white powder, which has a specific gravity of 6.53, by heating the hydroxide, oxalate, carbonate, or nitrate. It combines with water with evolution of heat, like lime, with formation of a voluminous snow-white powder of *Lanthanum Hydroxide*, $\text{La}(\text{OH})_3$, which is also obtained by precipitating a lanthanum salt with an alkali in the form of a gelatinous precipitate which easily absorbs carbon dioxide from the air. The hydroxide has an alkaline reaction and decomposes ammonia salts on heating.

SALTS OF LANTHANUM.

252 *Lanthanum Chloride*, LaCl_3 . This body is obtained in the anhydrous state by heating its ammonium double salt. It is a crystalline mass very soluble in water and alcohol. When the oxide is dissolved in hydrochloric acid, and the solution is evaporated to a syrup, large prisms having the composition $\text{LaCl}_3 + 7\text{H}_2\text{O}$ are deposited, and these when heated lose hydrochloric acid.

Lanthanum Sulphate, $\text{La}_2(\text{SO}_4)_3 + 9\text{H}_2\text{O}$, crystallises in six-sided pointed prisms which are more soluble in cold than in hot water. One part of the anhydrous salt dissolves at 13° in less than 6 parts, whilst at 100° it dissolves in about 115 parts of water.

Lanthanum Nitrate, $\text{La}(\text{NO}_3)_3 + 6\text{H}_2\text{O}$, is a salt easily soluble in water and alcohol, crystallising in oblique prisms or tables.

Lanthanum Carbonate, $\text{La}_2(\text{CO}_3)_3 + 8\text{H}_2\text{O}$. This occurs as lanthanite, a mineral which contains varying quantities of cerium and crystallises in greyish-white, pink, or yellowish rhombic prisms. It occurs at Bastnäs in Sweden: also in Silurian lime-

stone with the zinc ores of the Saucon Valley, Lehigh County, Pa, and in other localities in the United States. When a lanthanum salt is precipitated with a soluble carbonate, this same salt is obtained in the form of glittering scales.

Lanthanum Sulphide, La_2S_3 , is obtained by heating the oxide in the vapour of carbon disulphide, in the form of a yellow mass which is decomposed by water.

DETECTION AND ESTIMATION OF LANTHANUM.

253 Lanthanum chloride yields a spectrum consisting of many very bright and characteristic lines, by means of which even traces of the metal can be readily detected. The salts of lanthanum possess an astringent sweet taste. Their most important reactions have already been described.

Lanthanum is determined quantitatively by precipitating it either as hydroxide or as oxalate, these being converted by ignition into the oxide.

The *atomic weight* of lanthanum has been determined by many chemists, but with varying results. The latest experiments of Cleve¹ give the number 138.95 to 139.45, whilst Holzmann obtained values varying from 138.3 to 139.8. Hermann found 139.2, and Zschiesche² obtained 135.1.

CERIUM, Ce = 141.2.

254 This metal was first prepared by Mosander, in the form of powder, by heating the chloride with sodium. Wöhler afterwards obtained it in the coherent state, and Hillebrand and Norton have prepared it in large quantity by the electrolysis of the chloride. It possesses the colour and lustre of iron, and is tolerably permanent in dry air, but in moist air tarnishes, becoming first of a yellow, then of a blue, and finally of a green colour. It possesses the hardness of calc-spar and can be hammered and rolled, and, when warm, drawn into wire. The electrolytically prepared metal has a specific gravity of 6.628, but after melting under common salt it has a specific gravity of 6.728. Cerium melts at a lower temperature than silver, but at a higher one than antimony. It takes fire more easily than magnesium, and when scratched with a wire, or scraped with a

¹ *Bull. Soc. Chim.* [2] xxi. 196.

² *Journ. pr. Chem.* cvii. 65.

knife the particles of finely-divided metal which are rubbed off take fire. The same phenomenon is observed when the metal is struck with a piece of flint, sparks of the metal flying off and burning with great brilliancy. The metal also burns in the flame with a much more brilliant light than magnesium. It reacts upon the elements of the chlorine group, upon water, and upon acids in a similar way to lanthanum, but it is not attacked in the cold by concentrated nitric acid.

CERIUM AND OXYGEN.

255 Cerium is distinguished from the other metals of this group by forming two oxides; (1) a sesquioxide, Ce_2O_3 , and (2) a dioxide, CeO_2 . The latter acts as a weak base, and in many respects as a peroxide.

Cerium Sesquioxide, Ce_2O_3 , is obtained as a bluish-green powder by heating the oxalate or carbonate in a current of hydrogen gas. When caustic soda is added to its salts a white voluminous precipitate of the hydroxide is thrown down. This on exposure to the air takes up oxygen and carbon dioxide, and becomes coloured yellow.

Cerium Dioxide, CeO_2 , is formed when a cerium salt containing a volatile acid is heated in the air. It is a white or pale straw-coloured powder. On heating it becomes dark-red, but on cooling it assumes its original tint. When cerous chloride is ignited with borax in a wind furnace, the dioxide is obtained in the form of crystals.¹ On heating in a current of hydrogen it is first reduced to the sesquioxide and afterwards to metal. It dissolves in hydrochloric acid, yielding a lemon-yellow coloured solution, which on heating forms the sesquichloride, chlorine being at the same time evolved. Concentrated sulphuric acid also dissolves it with a dark-yellow colour; the solution is a powerful oxidising agent, and evolves considerable quantities of ozonised oxygen.

On heating the acid sulphate with caustic potash, or by the action of chlorine upon water containing the hydroxide of the sesquioxide in suspension, the compound $Ce(OH)_4 + CeO(OH)_2$ is formed, and this on drying forms a sulphur-yellow powder.

¹ Nordenskiöld, *Pogg. Ann.* cxiv. 612.

SALTS OF CERIUM.

256 Two series of salts are known corresponding to the oxides. They are termed the cerous and the ceric salts.

CEROUS SALTS.

Cerous Chloride, CeCl_3 , is formed as a yellowish-white sublimate when the metal is heated in chlorine, or when an intimate mixture of the oxide and carbon is heated in this gas. The hydrated salt, $2\text{CeCl}_3 + 5\text{H}_2\text{O}$, remains behind as ill-defined crystals when a solution of cerous oxide in hydrochloric acid is allowed to evaporate over sulphuric acid. On heating, it decomposes with evolution of hydrochloric acid and formation of a basic chloride.

Cerous Bromide, $2\text{CeBr}_3 + 3\text{H}_2\text{O}$, forms deliquescent needles, which, when heated in the air, decompose with evolution of bromine.

Cerous Iodide, $\text{CeI}_3 + 9\text{H}_2\text{O}$, forms transparent easily soluble crystals, which readily decompose with evolution of iodine.

Cerous Fluoride, CeF_3 , is a white precipitate.

Cerous Sulphate, $\text{Ce}_2(\text{SO}_4)_3$, separates in the anhydrous state from a warm solution, and dissolves in six parts of cold, and about sixty parts of hot water. When the solution is evaporated at a moderate temperature the salt $\text{Ce}_2(\text{SO}_4)_3 + 9\text{H}_2\text{O}$ crystallises out. Other hydrates are also known.

Potassium-Cerous Sulphate, $3\text{K}_2\text{SO}_4 + \text{Ce}_2(\text{SO}_4)_3$, is formed when an equal or greater weight of potassium sulphate is added to a solution of cerous sulphate. It dissolves in about fifty-six parts of water at 20° , and is almost insoluble in a concentrated solution of potassium sulphate. It dissolves, however, readily in acidified water, and on slow evaporation a double salt, $\text{Ce}_2(\text{SO}_4)_3 + 2\text{K}_2\text{SO}_4 + 3\text{H}_2\text{O}$, crystallises out.

If less than the above proportion of potassium sulphate be added to a solution of cerous sulphate, another salt having the composition $\text{Ce}_2(\text{SO}_4)_3 + \text{K}_2\text{SO}_4$ is formed as a granular crystalline mass.

Sodium and ammonium sulphate also form with cerium difficultly soluble double salts.

Cerous Nitrate, $\text{Ce}(\text{NO}_3)_3 + 6\text{H}_2\text{O}$, is a crystalline mass which

begins to decompose about 200°. It is easily soluble in water, and in alcohol, and forms crystalline double salts with other nitrates.

Cerous Phosphate, CePO_4 , occurs in the mineral monazite, $(\text{CeLaDi})\text{PO}_4$. This mineral often contains thorium, tin, manganese, and calcium in varying quantities. It crystallises in brownish hyacinth-red monoclinic crystals, and occurs in the Urals, in Norway, and in several localities in the United States.

Cerous Carbonate, $\text{Ce}_2(\text{CO}_3)_3$, occurs in lanthanite, and may be obtained by precipitating a solution of cerous sulphate with carbonate of ammonia. The precipitate thus obtained has the composition $\text{Ce}_2(\text{CO}_3)_3 + 9\text{H}_2\text{O}$, and on standing it assumes the form of small silky needles.

CERIC SALTS.

257 *Ceric Sulphate*, $\text{Ce}(\text{SO}_4)_2 + 7\text{H}_2\text{O}$, is obtained by dissolving the dioxide in dilute sulphuric acid and evaporating the salt in a vacuum over sulphuric acid. It is then deposited in the form of reniform masses consisting of fine crystals. In the moist state these are brown, whilst when dried they are yellow. When an excess of concentrated sulphuric acid is poured on the dioxide and the solution, diluted with water, gradually allowed to evaporate, the salt $\text{Ce}_2(\text{SO}_4)_3 + 2\text{Ce}(\text{SO})_2 + 25\text{H}_2\text{O}$ is deposited in fine red crystals resembling those of bichromate of potash, whilst from the mother liquor yellow crystals of $\text{Ce}(\text{SO}_4)_2 + 4\text{H}_2\text{O}$ are deposited.

Ceric sulphate forms double sulphates with the sulphates of the alkali-metals, such as $\text{Ce}(\text{SO})_2 + 2\text{K}_2\text{SO}_4 + 2\text{H}_2\text{O}$, a compound which is deposited in small yellow monoclinic crystals. Ceric sulphate is decomposed by water with formation of basic salts, from which water extracts more and more acid, and thus, according to the quantity of water present, salts possessing different compositions can be obtained.

Ceric Nitrate is formed by dissolving the dioxide in nitric acid. The red solution is decomposed by water, with separation of a basic salt. If potassium nitrate be added to the acid solution and the liquid allowed to crystallise in a vacuum over lime, yellow glistening six-sided prisms are deposited, having the composition $2(\text{Ce}(\text{NO}_3)_4 + 2\text{KNO}_3) + 3\text{H}_2\text{O}$. Ceric nitrate also forms double salts with other nitrates.

Cerium Sulphide, Ce_2S_3 , is formed when the metal is burnt in

the vapour of sulphur or when the oxide is heated in carbon disulphide vapour. When the oxide is fused with three parts of sodium pentasulphide and the fused mass lixiviated with water, cerium sulphide is obtained in small crystals resembling Mosaic gold, which do not undergo alteration on exposure to the air.

DETECTION AND ESTIMATION OF CERIUM.

258 The spark spectrum of cerium contains a number of bright lines, of which the three brightest and most characteristic lie in the green. A characteristic reaction for the cerium compounds is the precipitation of red ceric hydroxide when sodium hypochlorite is added to a colourless cerous salt; this dissolves in warm hydrochloric acid with evolution of chlorine. The other reactions have already been described.

In order to determine cerium quantitatively the solution is precipitated with caustic potash, and the washed and dried precipitate heated in the air in order to convert it into the dioxide.

The *atomic weight* of cerium has been determined by several chemists. Bunsen¹ and Rammelsberg² found the number 138, but according to the most recent investigations of Bülrig,³ who prepared his salts with the greatest care, the atomic weight of cerium is most probably 141.2.

DIDYMIUM. Di = 147.

259 Marignac was the first to prepare metallic didymium by heating the chloride with potassium. He obtained the metal in the form of a green powder or in very small globules. Hillebrand and Norton have recently obtained it in larger quantity by the electrolysis of the fused chloride. In its chemical properties it resembles in every respect the foregoing metals, but is more closely allied to lanthanum than to cerium. It possesses, however, a darker colour than this metal, and has a slightly yellow tint; it tarnishes with a yellow colour on exposure to the air, and the filings of the metal burn with a splendid bright light when held in the flame. Didymium has a specific gravity of 6.544.

Didymium Oxide, Di_2O_3 , is formed by igniting the hydroxide

¹ *Ann. Chem. Pharm.* lxxxvi. 265, and cv. 40.

² *Pogg. Ann.* cviii. 40.

³ *Journ. pr. Chem.* cxii. 209.

or a salt containing a volatile acid. It is a dirty-blue mass having a specific gravity of 6.852. The *hydroxide*, $\text{Di}(\text{OH})_3$, is a slightly rose-red precipitate, which on drying has a reddish-grey colour. Both compounds decompose ammoniacal salts on heating.

SALTS OF DIDYMIUM.

260 *Didymium Chloride*, $\text{DiCl}_3 + 6\text{H}_2\text{O}$, forms rose-red monoclinic crystals, which are easily soluble in water and which decompose on heating. When the solution of the salt mixed with sal-ammoniac is evaporated to dryness and the residue ignited in absence of air, the anhydrous salt is obtained as a fibrous crystalline rose-red mass.

Didymium Bromide, $\text{DiBr}_3 + 5\text{H}_2\text{O}$, crystallises in violet prisms, which do not deliquesce on exposure to the air.

Didymium Sulphate, $\text{Di}_2(\text{SO}_4)_3 + 8\text{H}_2\text{O}$, crystallises readily in large rose-red lustrous six-sided prisms, which completely lose their water of crystallisation at 200° . When the cold concentrated solution is boiled, a crystalline precipitate, having the composition $\text{Di}_2(\text{SO}_4)_3 + 2\text{H}_2\text{O}$, separates out.

Didymium Nitrate, $\text{Di}(\text{NO}_3)_3 + 6\text{H}_2\text{O}$, forms large violet crystals, which are very easily soluble in water and alcohol. The concentrated solution has a violet colour, and when diluted it assumes a rose-red tint.

Didymium Carbonate, $\text{Di}_2(\text{CO}_3)_3$, is a red crystalline powder obtained by passing carbon dioxide through water containing the hydroxide in suspension.

Didymium Sulphide, Di_2S_3 , is obtained as a greenish-brown powder by the ignition of the oxide in the vapour of carbon disulphide. It is slowly decomposed by water and quickly by dilute acids.

DETECTION AND ESTIMATION OF DIDYMIUM.

261 Didymium chloride gives in the spark-spectrum indications of lines in the green, which are, however, too weak to be used as a satisfactory means for its detection. On the other hand, the absorption spectrum of the solid and dissolved salts of didymium is very characteristic, and serves as a most delicate test for the presence of this metal; so much so that small traces

of the metal can thus be detected even in the presence of other coloured solutions.

Bunsen¹ has moreover observed that the absorption-spectrum of didymium undergoes certain remarkable changes, if examined by polarised light, according as the ordinary or the extraordinary ray is allowed to pass through the crystal; whilst differences are also noticed in the position of the dark bands dependent upon the nature of the didymium compound under examination. The changes are too minute to be seen with a small spectroscope, but are distinctly observed with a large instrument. "The differences thus observed," says Bunsen, "in the absorption spectra of different didymium compounds cannot, in our complete ignorance of any general theory for the absorption of light in media, be connected with any other phenomena. They remind one of the slight gradual alteration in pitch which the notes from a vibrating elastic rod undergo when the rod is weighted, or of the change of tone which an organ-pipe exhibits when the tube is lengthened."

The didymium salts, which possess a sweetish taste, are distinguished by their rose-red or violet colour, and they impart this colour to a bead of microcosmic salt when heated with this reagent in the blowpipe flame. The glass thus obtained also shows the characteristic didymium absorption lines. In its other reactions didymium resembles lanthanum and cerium.

It is usual to estimate didymium by precipitation as the oxalate, and this is converted by ignition into the oxide.

The *atomic weight* of didymium is according to Marignac 148, and according to Hermann 142.5, whilst from the most recent experiments of Cleve² the number 147 is deduced.

TERBIUM. Tr. = 148.5.

262 This metal has not yet been isolated. It occurs in considerable quantities in the samarscite of North Carolina, which mainly consists of the niobates of iron, yttrium, erbium, and terbium. The separation of terbium from the other metals of this group is attended with great difficulties, and a complete method of separation from erbium has not yet been found.

Terbium Oxide, Tr_2O_3 , is a dark orange-yellow powder, which

¹ *Phil. Mag.* [4] xxxii. 177.

² *Bull. Soc. Chim.* [2] xxi. 246.

becomes colourless when heated in hydrogen without loss of weight.

Terbium Sulphate, $\text{Tr}_2(\text{SO}_4)_3 + 8\text{H}_2\text{O}$, forms colourless crystals isomorphous with the corresponding sulphates of yttrium, didymium, and erbium.

The terbium salts are colourless and do not yield any absorption spectrum. The *atomic weight* of the metal has not yet been accurately determined, as the salts could not be obtained free from erbium.¹

ERBIUM. Er. = 169.

263 This metal is not known in the free state. Its salts closely resemble those of yttrium.

Erbium Oxide, Er_2O_3 , is a white powder in the pure state, but generally, in consequence of the presence of higher oxides, it has a yellow tint. The *hydroxide* is a white precipitate, which, after ignition, leaves the oxide in the form of a white powder resembling alumina, which dissolves only slowly in acids.

The salts of erbium, which have been completely investigated by Cleve and Hoeglund, have a similar composition to those of yttrium, but are distinguished from them by their pale-rose tint and their characteristic absorption-spectrum, which is totally different from that of didymium.

A remarkable fact respecting erbium is that when its oxide is ignited the spectrum is a continuous one, interrupted by a number of bright bands, and the points of maximum intensity of this luminous spectrum correspond in position with the points of greatest darkness in the absorption-spectrum (Bahr and Bunsen). By this means it is easy to distinguish erbium from any other metal. The spark spectrum of the chloride is different from the bright spectrum of the erbium oxide, and it is not specially characteristic.

The *atomic weight* of erbium is, according to Bahr and Bunsen, 168.9, and according to Cleve and Hoeglund, 170.5.

The following extract from Bunsen's memoir² shows how easily the presence of the metals of this group can be distinguished by means of the spectroscope: "A few centigrams of cerite from the Bastuüs quarry evaporated with hydrochloric

¹ Delafontaine and Marignac, *Arch. Sc. Phys. Nat. Genève*, 1878, 273, 283.

² *Phil. Mag.* [4] 1. 537.

acid, and taken up with the same acid and water, gave a concentrated solution which behaved as follows:—The light passed through it showed the characteristic absorption spectrum of didymium. As no trace of the characteristic absorption-lines of erbium appeared, the absence of erbium in this cerite was proved. The carbon points saturated with the liquid gave a spark spectrum, in which ten lanthanum lines and three cerium lines appeared clearly. Similarly a solution of gadolinite from Ytterby in hydrochloric acid gave, after separation of silica, the didymium absorption-bands; those of erbium appeared faintly. The calcium and sodium lines were slightly visible, and the yttrium lines appeared very plainly in the spark-spectrum, the characteristic group in the orange being especially prominent. A cerium line was also seen, but no lanthanum lines; and as the latter spectrum is a very well marked and characteristic one, the absence of more than a trace of this metal may be inferred. Yttrium, erbium, didymium, cerium, calcium, and sodium were therefore found in this mineral."

METALS OF THE ALUMINIUM GROUP.

Aluminium.

Indium.

Gallium.

264 These metals form feebly basic sesquioxides, of which alumina, Al_2O_3 , may be taken as a type. The sulphates of these oxides form double salts with the sulphates of the alkali-metals, which crystallise in regular octohedrons, and of which common alum, $\text{Al}_2(\text{SO}_4)_3 + \text{K}_2\text{SO}_4 + 24 \text{H}_2\text{O}$, is the best known.

ALUMINIUM. Al = 27.3.

The name of this metal is derived from *alumen*, alum. This as well as the corresponding Greek word (*στυπτηρία*), was originally used to designate very different bodies, all of which possess the common property of an astringent taste. There can, however, be little doubt that alum itself was included amongst these bodies, and this salt was well known to Geber and the later alchemists, being, however, classed amongst the vitriols, until Paracelsus showed that it differed from this last family of salts. In his second treatise, *De Generibus Salium*, he states: "Alum is in no wise connected with the metals, but is a salt, standing alone in the acid, and taking its *corpus* from the intermixture of the earths; vitriol does not do so, but solely from the intermixture of metallic *corpores*." The nature of the earth, which is combined in alum with sulphuric acid, remained long undetermined. It was usually supposed to be a calcareous earth, although it was noticed in the seventeenth century that clay, when treated with sulphuric acid, gives an alum; and hence Pott, in his *Lithognoisy*, published in 1746, states that the basis of alum is an argillaceous earth. It was not till 1754 that

Marggraf showed that alumina differs totally in its properties from lime, and that clay contains this earth, combined with silica.

Davy, as well as other chemists, endeavoured to decompose it into its elements, as it was generally acknowledged to be an oxide. The results they obtained were, however, but unsatisfactory, and Wöhler, in 1827, was the first to prepare pure aluminium.

Of all the elements, with the exceptions of oxygen and silicon, aluminium is the most widely distributed, and contained in the largest quantity in the solid crust of the earth. It occurs as the oxide, Al_2O_3 , in the mineral corundum, of which the ruby and sapphire are varieties. It is found more commonly as diaspore, $\text{Al}_2\text{O}_3\cdot\text{H}_2\text{O}$, and bauxite, $\text{Al}_2\text{Fe}_2\text{O}_5\cdot\text{H}_2\text{O}$, whilst it occurs in far larger quantity in combination with silica, forming a great variety of double silicates, amongst which potash-felspar, or orthoclase, $\text{K}_2\text{Al}_2\text{SiO}_6$, may be mentioned as being most important, as this forms the chief constituent of granite, gneiss, syenite, porphyry, trachyte, &c. Soda-felspar, or albite, and lime-felspar, or labradorite, also occur in large quantities. Amongst other important double silicates we find the garnet group. The several members of this group are named from the different isomorphous metals which they contain; thus, for instance, we have lime-alumina garnet or grossular, $\text{Ca}_3\text{Al}_2\text{Si}_3\text{O}_{12}$; iron-alumina garnet, or almandite, $(\text{FeMg})_3\text{Al}_2\text{Si}_3\text{O}_{12}$; lime-iron garnet, or andradite, $\text{Ca}_3\text{Fe}_2\text{Si}_3\text{O}_{12}$. The group of micas also contains a large number of important minerals, as common mica or biotite, $4\text{KH}(\text{MgFe})_6\text{Al}_2\text{Si}_{16}\text{O}_{32}$; and chlorite or ripidolite, $\text{H}_8(\text{MgFe})_6(\text{AlFe})_2\text{Si}_3\text{O}_{18}$, the latter compound forming the chief constituent of many slate rocks.

The weathering of felspar gives rise to porcelain-clay, china-clay, or kaolin, $\text{Al}_2\text{Si}_2\text{O}_7 + 2\text{H}_2\text{O}$, whilst the various varieties of coloured clays are obtained from a similar disintegration of felspathic rocks containing iron.

Although alumina is largely contained in all fertile soil, it is not taken up by plants, with the exception of a few cryptogams, especially the species of lycopodiums. The ash of *L. Clavatum* contains up to 26.65, and that of *L. Chamaecyparissus* even as much as 57.26 per cent. of alumina, whilst other plants, such as oak, fig, and birch grown in the same soil contain none.¹ Aluminium is also contained in the solar atmosphere.

¹ Aderholdt, *Ann. Chem. Pharm.* lxxxii. 111.

265 Preparation of Metallic Aluminium.—The process which Wöhler employed for the preparation of aluminium is that which is now made use of for the preparation of all those elements which occur in nature combined with oxygen, and whose oxides are not reducible either in the presence of carbon or of hydrogen. Wöhler¹ prepared it by fusing together potassium and chloride of aluminium in a closed crucible. It is thus obtained in the form of a grey powder, which, under the burnisher, exhibits a metallic lustre, and when pressed in an agate mortar adheres together in the form of glittering particles.

Wöhler afterwards improved his method, and, by passing the vapour of aluminium chloride over potassium, obtained the metal in fused globules.² In the year 1854 Bunsen prepared aluminium by electrolysis of the chloride, and in the same year Deville commenced his first experiments on the preparation of aluminium on a large scale. The process he employed was that of Wöhler, replacing, however, potassium by sodium, and he found that instead of the pure chloride it was preferable to use the double chloride of aluminium and sodium. In the Paris Exhibition of 1855 the "silver made from clay" naturally attracted great attention. Deville then, in concert with other chemists, extended his experiments, and with their help the process was still further improved, and aluminium was first prepared on the large scale at works near Alais, under the direction of M. Merle.

The raw material for the production of the metal on the large scale is the mineral bauxite $(\text{AlFe})_2\text{O}_6\text{H}_4$, which contains about 50 per cent. of alumina, and 25 per cent. of iron oxide, together with silica and other impurities. This is pulverised and heated with soda in a reverberatory furnace, when sodium aluminate is formed, and this is dissolved out of the cold mass by water. The clear solution is decomposed by passing a current of carbon dioxide through it, when sodium carbonate is formed and a precipitate of alumina thrown down; this is collected on linen filters and well washed. After drying it forms a white powder, which is then mixed with common salt and coal-dust, and the mixture formed into balls, which are then rapidly dried. These are placed in an upright retort (Fig. 115), built of fireclay slabs, and the temperature slowly raised until a white-heat is reached, and then dry chlorine

¹ *Pogg. Ann.* xi. 146.

² *Ann. Chem. Pharm.* xvii. 47, and liii. 422.

³ *Pogg. Ann.* xcii. 648.

led in at the lower part of the retort. The double chloride of aluminium and sodium volatilises and passes through a tube at the upper end of the retort, and is deposited in a side chamber (L) made of fireclay slabs, carbonic oxide and the excess of chlorine being led away by a tube to the chimney. In the manufacture 100 kilos. of the double chloride are mixed with 35 kilos. of sodium and 40 kilos. of cryolite, which last serves as a flux. The whole mixture is brought on to the floor of a reverberatory furnace, the temperature of which is gradually raised until the whole is fused. The fused metal collects on the hearth of the furnace, and is then cast into moulds.¹ The

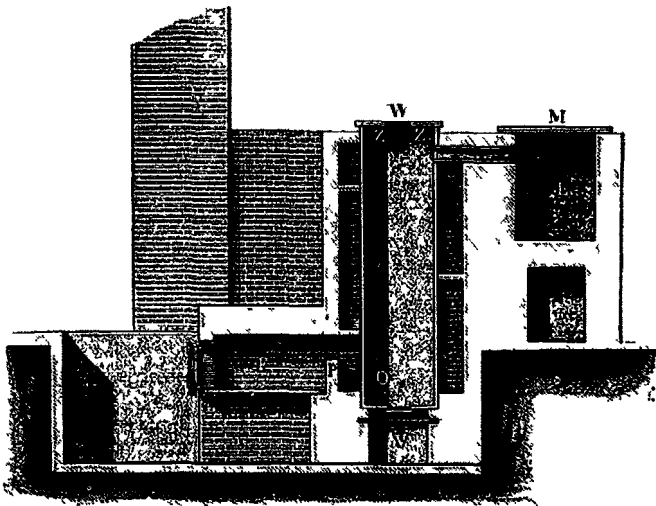

FIG. 115.

aluminium thus prepared is not pure, always containing iron and some quantity of silicon.

266 Properties.—Aluminium is a tin-white metal, which is capable of assuming a bright polish. The appearance of objects made of aluminium is, however, improved by giving to the surface of the metal a dead appearance. This is accomplished by acting on the surface with weak soda-lye, and afterwards washing with dilute nitric acid. Aluminium is malleable, and can be drawn into fine wire, and hammered into very thin leaf. It can be

¹ Wurtz, *Ber. Entsc. Indust.* 657.

best worked at a temperature of 100° to 150° . In the compact state it is very sonorous, emitting a tone when struck like that of flint glass. The cast metal has a specific gravity of 2.56, and is as hard as silver, whilst the hammered metal has a hardness of soft-iron, and a specific gravity of 2.67. The hardness is again diminished on further heating. It fuses at about 700° . In order to re-melt the metal a fusing mixture of common salt and potassium chloride must be employed, as the presence of other fluxes, such as borax, glass, &c., render the metal very impure. On slowly cooling it assumes a crystalline structure, the forms indicating that it crystallises in octohedrons. It conducts electricity eight times better than iron, and heat somewhat better than zinc. Pure aluminium does not oxidise at ordinary temperatures on exposure to air; but the impure metal soon becomes covered with a thin coating of oxide. When heated in oxygen it oxidises only on the surface without combustion. If a fine aluminium wire be wound round a piece of charcoal the metal burns brightly with the charcoal in oxygen, and if a piece of thin aluminium foil or leaf be heated in a glass globe in an atmosphere of oxygen it burns with a sudden flash of intensely white light. Aluminium foil decomposes water at 100° , being slowly converted into the hydroxide which retains the form of the foil. The metal dissolves readily in aqueous alkalis, with evolution of hydrogen, and it deposits the metals, lead, silver, and zinc from alkaline solutions, whilst neutral or acid solutions are not altered by it. It precipitates metallic copper from a solution of copper sulphate.

Hydrochloric acid is the best solvent for aluminium. Dilute sulphuric acid, however, also dissolves it with evolution of hydrogen, and concentrated sulphuric acid dissolves it on heating with evolution of sulphur dioxide. On the other hand concentrated, as well as dilute nitric acid, is without action on the metal. Organic acids attack it only slightly, but it dissolves in them with ease in the presence of chlorides such as common salt. Hence it cannot be used for plating cooking utensils. According to Wöhler aluminium foil takes fire in a current of chlorine, but according to Böttger this is only the case when it is tied round with brass wire to which some Dutch metal is fastened. At high temperatures aluminium also combines with sulphur, selenium, tellurium, phosphorus, and arsenic, and it forms with many metals characteristic alloys.

Aluminium possesses so many valuable properties, such, for

instance, as its low specific gravity, fine lustre, unalterability in the air and in sulphuretted hydrogen, non-poisonous qualities, and ease of working, that a widespread application of the metal might be looked for; and in the London Exhibition of 1862 a large number of various objects of aluminium were shown. The hopes which were then entertained concerning its general applicability have unfortunately not been fulfilled, and at the present time it is chiefly used for the manufacture of opera-glasses and physical apparatus where lightness and strength are especially requisite. Some of the alloys of aluminium are rather largely used, but the high price of the metal and its alloys seems fatal to its general employment. The cost of production is about 80 francs per kilo., and it is sold at about 100 francs; and at present there is no prospect of the cost of manufacture being much reduced.¹ In spite of this, many branches of manufacture as well as of science are much indebted to the establishment of the aluminium industry, for by this means the minerals bauxite and cryolite were brought into large use, whilst the price of sodium, which in 1852 was ten shillings an ounce, is now reduced to five shillings per pound. At the present time pure caustic soda is prepared from sodium, and if we bear in mind how valuable sodium has proved in scientific research, and remember the great progress which has been made in every branch of chemical science by the use of this metal, we may form an idea of the importance of the manufacture of sodium, and, therefore, of that of aluminium, which gave the impetus to the cheap preparation of the alkali metal.²

267 *Alloys of Aluminium.* Copper forms an alloy with aluminium possessing the colour of gold. That containing about 10 per cent. of the latter metal is usually known as aluminium bronze, and possesses the appearance of standard gold. For the preparation of this alloy chemically pure copper must be employed, as that which contains iron yields an inferior product. The alloy is at first brittle, but when fused several times it acquires valuable properties. Thus it becomes malleable, yields fine castings, takes a high polish, and has a tensile strength equal to cast steel. As in the case of aluminium, great hopes were entertained of the general employment of this alloy, as it is less alterable in the air than either brass or bronze. Rifle-barrels and even rifle-cannon have been made from it. These

¹ Crude and manufactured Aluminium can be obtained from the Société Anonyme de l'Aluminium 21, Boulevard Poissonnière, Paris.

² Biedermann, *Ber. Entw. Chem. Ind.* 599.

appear to answer admirably, but the high price of 15 francs per kilo. has prevented the general employment of the alloy. It is, however, now used for the manufacture of physical apparatus as well as of ornamental goods. Aluminium can be alloyed with silver, yielding a hard, easily-polished alloy. That containing 4 per cent. of silver has been employed for the construction of beams for chemical balances, on account of its lightness and its unalterability in the air.

Aluminium also combines with mercury when it is moistened with caustic alkali, or when the two metals are fused together in an indifferent gas. The amalgam is very brittle, oxidises easily in the air, and decomposes water at the ordinary temperature. When a piece of aluminium is rubbed with leather which is impregnated with mercury the metallic surface becomes hot, and in a few moments warty concretions of the oxide are formed.¹

ALUMINIUM AND OXYGEN.

268 *Aluminium Oxide* or *Alumina*, Al_2O_3 , is found in nature in the form of the mineral corundum, crystallising in hexagonal prisms, and of which there are several varieties. The more or less colourless crystals as well as those which are coloured brown by ferric oxide and which are either translucent or opaque are called corundum; those which are coloured red by chromium compounds are termed ruby, whilst those which have a blue tint, due probably to cobalt, are termed sapphires. The yellow crystals are termed oriental topaz, and the purple oriental amethyst, whilst the green are termed oriental emeralds. Coarse and granular corundum containing magnetite or hæmatite intimately mixed with it, and having a grey or blackish colour, is termed emery. Of this mineral there are many gradations, from the finely ground emery to those kinds in which the corundum is present in distinct crystals. Crystallised alumina is only second in hardness to the diamond, and hence it is largely used for polishing and grinding the surfaces of glass and metal.

When aluminium hydroxide or aluminium salts containing volatile organic acids are heated, alumina remains either as a white powder or in amorphous gum-like masses. If this be not too strongly ignited it dissolves in concentrated acids, which, however, do not attack the crystallised compound. When more

¹ Jehn and Hinze, *Ber. Deutsch. Chem. Ges.* vii. 1493.

strongly ignited, amorphous alumina becomes denser and harder. After ignition in the flame of the spirit-lamp it has a specific gravity of 3.5, and when more strongly heated in a porcelain-kiln, it attains a specific gravity of 3.9. It is then nearly as hard as corundum, but still amorphous (H. Rose). Alumina melts in the oxy-hydrogen flame to a thin liquid, which, on cooling, assumes a crystalline structure and possesses all the properties of corundum. A similar oxide may be obtained by the combustion of the finely divided metal. If aluminium hydroxide be moistened with potassium bichromate and the dried mass fused before the oxy-hydrogen blowpipe artificial ruby is obtained (Gaudin), and the same material may be prepared by heating to whiteness a mixture of borax and amorphous alumina containing a small quantity of chromium sesquioxide (Ebelmen). Crystallised alumina is also obtained when fluoride of aluminium is allowed to act upon boron trioxide at a very high temperature (Deville and Caron), or when aluminium phosphate is fused with sodium sulphate (Debray).

Fremy and Feil¹ have recently obtained crystallised alumina on the large scale by heating equal parts of alumina and lead oxide to a bright red-heat. The product consists of two distinct layers: one of lead silicate derived from the action of the lead oxide upon the silica of the crucible; the other layer is a vitreous mass, and contains cavities filled with colourless crystals of corundum. By the addition of from 2 to 3 per cent. of bichromate of potash to the materials, crystals of ruby were obtained, whilst crystals of sapphire were prepared by adding a trace of oxide of cobalt. Splendid crystals of rose-red coloured ruby were obtained by heating a mixture of equal parts of alumina and barium fluoride with from 2 to 3 per cent. of potassium bichromate to a very high temperature in a glass furnace. This is explained by the production of a volatile fluoride of aluminium which undergoes decomposition in contact with the gases of the furnace with evolution of hydrofluoric acid and deposition of crystalline alumina, the crystals being found in the upper part of the crucible. In these experiments a crystalline double silicate of barium and aluminium is also formed. Artificial ruby and sapphire cannot be distinguished from the natural stones, so that important applications may be predicted for this discovery.

In order to obtain crystallised aluminium in solution it must

¹ *Phil. Mag.* [5] v. 47.

either be fused together with caustic potash or with acid potassium sulphate. It is also dissolved when heated in closed tubes with concentrated sulphuric acid.

269 Hydroxides of Aluminium. Several of these occur in nature. The most important are hydrargillite, $\text{Al}_2(\text{OH})_6$; diaspore, $\text{Al}_2\text{O}_3(\text{OH})_2$, both of which are crystalline; and bauxite $(\text{AlFe})_2\text{O}(\text{OH})_4$, which is found as an amorphous mass.

When ammonia is added to a soluble salt of alumina in the cold a gelatinous precipitate falls down; but when precipitated at the boiling point an opaque white precipitate is deposited, which when dried at the ordinary temperature forms a hard, horn-like mass having the composition $\text{Al}_2\text{O}_3 + 5\text{H}_2\text{O}$ or $\text{Al}_2(\text{OH})_6 + 2\text{H}_2\text{O}$. When heated to somewhat above 300° it gradually parts with water, forming the compound $\text{Al}_2\text{O}_3(\text{OH})_2$; and this on ignition yields alumina and water. In this latter reaction the finely divided particles exhibit a peculiar motion which continues even after removal of the flame.¹

Precipitated aluminium hydroxide possesses in high degree the power of withdrawing from solution both inorganic salts and organic bodies. This property is employed in the purification of drinking water as well as in the clarification of sugar-syrup before it is placed in the polarising apparatus.

Moderately ignited alumina readily takes up water with evolution of heat, but does not appear to form any definite compound. The freshly precipitated hydroxide is easily soluble in acids, but the naturally occurring crystallised hydroxides are only attacked by acids after moderate heating. At a bright red-heat they lose the whole of their water and fall with considerable decrepitation into a white powder consisting of the anhydrous oxide. Aluminium hydroxide is usually employed as the source from which the different salts of aluminium are obtained. Its preparation from cryolite has already been described under the alkali-manufacture, and that from bauxite in the description of the manufacture of aluminium.

Aluminium hydroxide also occurs in two soluble modifications. One of these, which when dried at 100° has the composition $\text{Al}_2\text{O}(\text{OH})_4 = \text{Al}_2\text{O}_3 + 2\text{H}_2\text{O}$ was obtained by Walter Crum² by preparing a solution of normal acetate of alumina by the mutual decomposition of lead acetate and aluminium sulphate. This, on heating, decomposes with separation of the

¹ Ramsay, *Chem. Soc. Journ.* 1877, ii. 395.

² *Chem. Soc. Quart. Journ.* vi. 216.

basic acetate, $\text{Al}_2(\text{C}_2\text{H}_3\text{O}_2)_4(\text{OH}_2) + \text{H}_2\text{O}$, which on treatment for one and a half hours with 200 times its weight of boiling water becomes soluble. If this solution be allowed to stand for ten days and nights at the temperature of boiling water in a closed flask, the acetic acid separates from the alumina. After a sufficient quantity of water has been added to reduce the percentage of alumina to 0.25, the liquid is heated in a flat basin to the boiling point, fresh water being constantly added to replace that lost by evaporation, until all the acetic acid has been driven off. The solution then is perfectly neutral and tasteless, but becomes gelatinous on evaporation.

The second soluble hydroxide of aluminium was obtained by Graham ¹ by dialysis of the basic chloride obtained by dissolving the hydroxide in the normal chloride. The normal salt passes through the parchment paper into the water, and a neutral tasteless solution containing alumina remains in the dialyser. This is very unstable, and after some days passes into a jelly. Both these soluble hydroxides are coagulated on the addition of traces of a salt, an acid, or an alkali. Graham's compound acts as a mordant uniting with colouring matter to form lakes, and in the coagulated state is readily soluble in acids. Crum's compound on the other hand, termed by Graham "meta-aluminium hydroxide," does not combine with colouring matter, and does not dissolve in excess of acid.

ALUMINATES.

270 Like other weak bases, alumina acts toward the stronger bases as an acid-forming oxide; thus precipitated alumina dissolves in caustic potash and soda.

Potassium Aluminate, $\text{K}_2\text{Al}_2\text{O}_4 + 3\text{H}_2\text{O}$, is obtained in hard glistening crystals when alumina and potash are fused together in a silver basin, the solid residue dissolved in water, and the solution evaporated in a vacuum.

Sodium Aluminate, $\text{Na}_2\text{Al}_2\text{O}_4$. This substance has not been obtained in the crystalline state. It is prepared on the large scale by fusing cryolite with lime, or bauxite with soda or sodium sulphate and carbon, as well as with common salt in a current of steam. When the melted mass is lixiviated with water and the solution evaporated to dryness, sodium aluminate is obtained. This substance serves as a mordant in dyeing and

¹ *Phil. Trans.* 1861, 183.

calico-printing, for the preparation of coloured lakes, and of pure alumina, and for the sizing of paper, &c.

Barium Aluminate, BaAl_2O_4 , is obtained by fusing alumina with baryta or barium nitrate. It is soluble in water and crystallises with four molecules of water.

Beryllium Aluminate, BeAl_2O_4 , occurs in nature as the mineral chrysoberyl. It forms rhombic crystals having an emerald green colour, and is found in Brazil, North America, Ceylon, Ireland, and other places, and is valued as a gem.

Magnesium Aluminate, MgAl_2O_4 . This substance occurs in nature as spinelle. It crystallises in the rhombic system, and is either colourless or variously tinted, and is classed in various species according as either the whole or a part of the magnesium and aluminium is replaced by isomorphous metals. Thus spinelle is $(\text{MgFe})(\text{AlFe})_2\text{O}_4$; zinc-spinelle or gahnite is $(\text{ZnFeMg})(\text{AlFe})_2\text{O}_4$, &c.

The naturally occurring aluminates have been artificially prepared by Ebelmen, by fusing alumina and the corresponding oxide with boron trioxide. This latter substance, which serves as a solvent, being almost entirely volatilised at a very high temperature. In this way colourless spinelle was obtained, and this was coloured red by chromium, blue by cobalt, and black by iron; and by a similar process the aluminates of barium, beryllium, iron, manganese, &c., can be prepared. Deville and Caron also obtained crystals of gahnite and chrysoberyl by heating aluminium fluoride, together with fluoride of zinc or beryllium, in a carbon crucible which contained a platinum basin filled with boron trioxide.

SALTS OF ALUMINIUM.

271 *Aluminium Chloride*, Al_2Cl_6 , was first prepared by Oersted by heating a mixture of carbon and alumina in a current of dry chlorine. This method was afterwards adopted and improved by Wöhler,¹ Liebig,² Bunsen,³ and Deville.⁴ On the large scale it is prepared in an apparatus similar to that used for the production of the double chloride of aluminium and sodium already described.

Pure aluminium chloride is a white crystalline solid. It

¹ *Pogg. Ann.* xi. 146.

² *Ibid.* xcii. 643.

³ *Ibid.* xvii. 43.

⁴ *Compt. Rend.* xxix. 321.

usually possesses, however, a yellowish or greenish colour, due to the presence of ferric chloride and other impurities. It volatilises slowly on heating without fusion, but if a large quantity be quickly heated the mass fuses and then boils, the vapours condensing at a temperature between 180° and 185° (Liebig). The specific gravity of the vapour, according to the experiments of Deville and Troost, is 9.3, corresponding to a vapour density of 133.4. Aluminium chloride is hygroscopic, absorbing water from the air, and emitting fumes of hydrochloric acid. It is also easily soluble in alcohol and ether.

When aluminium hydrate is dissolved in hydrochloric acid and the solution evaporated, large needle-shaped crystals are deposited, which have the composition $\text{Al}_2\text{Cl}_6 + 12\text{H}_2\text{O}$. These on further heating are easily decomposed into water, hydrochloric acid, and residual alumina.

Aluminium chloride absorbs dry ammonia gas, and yields a yellow powder of the composition $\text{Al}_2\text{Cl}_6 + 6\text{NH}_3$. When this is heated in a current of hydrogen the compound $\text{Al}_2\text{Cl}_6 + 2\text{NH}_3$, soluble in water, sublimes (Persoz). Aluminium chloride also combines with phosphorus pentachloride, phosphorus oxychloride, the chlorides of silver, selenium, and tellurium, as well as with other metallic chlorides.

Sodium Aluminium Chloride, $\text{Al}_2\text{Cl}_6 + 2\text{NaCl}$. The preparation of this compound on the large scale has already been described. It is obtained as a colourless crystalline mass which melts at 185° (Bunsen) and volatilises at a red-heat. It readily absorbs water, but in the compact state it is less hygroscopic than aluminium chloride, and for this reason it is used instead of the latter compound in the preparation of aluminium.

Aluminium Bromide, Al_2Br_6 . When aluminium and bromine are brought together they combine with evolution of heat, forming the above compound. It is obtained by passing the vapour of bromine over a heated mixture of alumina and carbon. It is a colourless crystalline body which melts at 80° , boils at a temperature between 265° and 270° and sublimes in crystalline scales. The specific gravity of the solid is 2.54, and that of the vapour 18.62 (Deville and Troost). In other respects it is analogous to the chloride, and forms the hydrate $\text{Al}_2\text{Br}_6 + 12\text{H}_2\text{O}$, which is also obtained by dissolving aluminium hydroxide in hydrobromic acid and carefully evaporating the solution.

Aluminium Iodide, Al_2I_6 , is formed when the metal and

iodine are heated together in closed tubes. It is deposited in colourless crystals which melt at 185° (Weber) and boil at a temperature of 360° . Its specific gravity is 2.63, and that of the vapour is 27. The vapour is combustible, giving rise to an explosive mixture when diluted with air. It is soluble in water, alcohol, and sulphide of carbon, and forms with the first of these solvents a crystalline compound $\text{Al}_2\text{I}_6 + 12\text{H}_2\text{O}$. Aluminium iodide has been employed for the purpose of converting organic chlorine compounds into iodides. Thus carbon tetrachloride yields the corresponding tetra-iodide when heated with aluminium iodide (Gustavson):

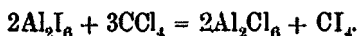

Aluminium Fluoride, Al_2F_6 , is best obtained by evaporating to dryness a solution of aluminium in hydrofluoric acid, and subliming the residue, contained in a carbon tube, in a current of hydrogen.¹ It forms transparent, very obtuse rhombohedral, which were formerly supposed to be cubes. It is permanent in the air, insoluble in water, and unaltered in the presence of acids and aqueous alkalis; but it is decomposed by long-continued fusion with sodium carbonate. Aluminium dissolves readily in excess of hydrofluoric acid. The solution appears to contain the compound, $\text{Al}_2\text{F}_6 + 6\text{HF}$. This corresponds to a series of double fluorides, of which the most important is—

Aluminium Sodium Fluoride, $\text{Al}_2\text{F}_6 + 6\text{NaF}$. This occurs as the mineral cryolite at Evigtok, in the Arksutfjord, on the west coast of Greenland, where it forms a bed 80 feet thick and 300 feet long. It was discovered in this locality by Andrada, at the end of the last century. Its mineralogical name was given to it by him inasmuch as it has an ice-like appearance. The investigations of Albidgaard showed that it contained hydrofluoric acid, alumina, and an alkali metal, and Klaproth found the alkali to be soda. The exact composition of cryolite was determined by Vauquelin, Berzelius, and Deville, and in 1849-1850 Julius Thomsen showed that this mineral can be decomposed in the dry way by means of lime and lime salts as well as by the wet way, and upon this observation an important Danish industry has been founded. Cryolite usually occurs in masses of a snow-white, reddish, brownish, or bluish colour, which possess easy cleavage; it is found more rarely in triclinic crystals. When this substance is boiled with milk of

¹ Brunner, *Pogg. Ann.* xxxiii. 488.

lime, or fused with limestone, sodium aluminate, and calcium fluoride are formed. When acted upon with concentrated sulphuric acid it evolves hydrofluoric acid, and the residue contains sodium sulphate, which may be dissolved by the action of cold water, the aluminium sulphate, which is formed at the same time, dissolving only in boiling water.

272 *Aluminium Sulphate*, $\text{Al}_2(\text{SO}_4)_3$, is obtained by dissolving the hydroxide in dilute sulphuric acid. It crystallises with difficulty, forming pearly six-sided monoclinic tablets containing eighteen molecules of water. It possesses a sweet astringent taste, dissolves in two parts of cold water, but scarcely at all in alcohol (Berzelius). The hydrated salt, $\text{Al}_2(\text{SO}_4)_3 + 18\text{H}_2\text{O}$, is found as the mineral *keramohalite* in the neighbourhood of active volcanoes, and in alum-shale. It melts on heating in its water of crystallisation, and then swells up, the anhydrous compound being left behind as a porous mass, dissolving only slowly again in water. At a red-heat it is decomposed, leaving a residue of pure alumina. The concentrated solution of this salt is a useful reagent for potassium salts, as potassium alum, $\text{Al}_2\text{K}_2(\text{SO}_4)_4 + 24\text{H}_2\text{O}$, is precipitated as a crystalline powder, which is altogether insoluble in an excess of aluminium sulphate.¹

Aluminium sulphate is prepared on the large scale, and is known in commerce under the name of concentrated alum or sulphate of alumina. For this preparation china-clay, as free as possible from iron, is employed. This is roasted in a reverberatory furnace, by which any iron which may be present is rendered insoluble, whilst the silicate of alumina becomes more soluble in sulphuric acid. It is then heated in leaden boilers with sulphuric acid of specific gravity 1.45, and the solution allowed to deposit the silica, and any undecomposed alumina. The clear liquid is then evaporated down until a small portion on cooling is found to solidify. After cooling, the soft mass is cut into square blocks, and thus brought into the market. This material is employed by the dyer as a mordant, and also for the purpose of weighting paper.

An impure product, known under the name of *alum-cake*, also used largely by paper-makers, is obtained by heating a white china-clay or bauxite with sulphuric acid. The whole mass then becomes solid. It consists of about 12 per cent. of soluble

¹ Wurtz, *Diet.* i. 174.

alumina as sulphate, together with silica and undecomposed aluminate.

For many purposes a sulphate perfectly free from iron is needed. This is prepared by dissolving the pure hydroxide in sulphuric acid.

According to Berzelius a series of basic sulphates of aluminium exists. These are probably mixtures. One of them occurs in clay deposits as the mineral aluminite or websterite. It forms an earthy mass, having the composition $\text{Al}_2(\text{SO}_4)(\text{OH})_4 + 7\text{H}_2\text{O}$. The same salt is formed when aluminium sulphate is precipitated with a quantity of ammonia insufficient to throw the whole of the alumina down. When a concentrated solution of aluminium sulphate is boiled with the freshly precipitated hydroxide a thick solution is formed, and this, on standing for some months, deposits a crust of small needle-shaped crystals, of a salt having the composition $\text{Al}_2(\text{SO}_4)_2(\text{OH})_2 + 2\text{Al}_2(\text{SO}_4)(\text{OH})_4 + 25\text{H}_2\text{O}$ (Rammelsberg).

THE ALUMS.

273 Aluminium sulphate forms with the sulphates of the alkali-metals double salts, which crystallise in regular octohedrons, of which the potassium double salt, $\text{Al}_2(\text{SO}_4)_3 + \text{K}_2\text{SO}_4 + 24\text{H}_2\text{O}$, has long been known under the name of *alum*. This name is, however, now used to designate a whole group of bodies. Alum appears to have been first prepared in the East, but exact particulars of its early history are wanting. We find the name occurring first in the writings of Geber, who speaks of an ice-alum, which is obtained from Roccha, and which he was able to purify by re-crystallisation. The alchemists of the West described this salt as *alumen de rocca*, in order to distinguish it from the vitriols, and this name was afterwards erroneously translated by the French chemists, who termed pure alum *alum de roche*.

In the thirteenth century an alum factory, erected by Italians, existed near Smyrna. They obtained their alum by roasting alum-rock, lixiviating the product, and crystallising. In the fifteenth century the Genoese erected alum works on the island of Ischia, and at the same time the celebrated works at Tolfa, in the Papal States, were established. The so-called Roman alum, which was there prepared, was, up to recent times, considered to be the best, and the manufacture has lately been

resuscitated, and 10,000 tons of alum are now being made annually at Tolfa by a French company. The material from which the alum is manufactured in the various places in Italy, as well as in Hungary, is the alum-rock, the chief constituent of which is the mineral alunite or alum-stone, which is itself a double compound of potassium sulphate and basic aluminium sulphate, possessing the formula $K_2SO_4 + 3Al_2(SO_4)(OH)_4$. The rock is a product of the action of steam and sulphur dioxide on trachyte, and consists chiefly of a mixture of quartz and alum-stone. This is mixed with fuel in heaps, or in a furnace similar to a lime-kiln, and the roasted mass exposed for some weeks to the air. It then falls to a soft material, which is lixiviated with hot water, and the clear liquid, on standing, is concentrated in copper pans, and allowed to crystallise in wooden vessels. The crystals have a slightly orange-red colour, a very characteristic property of Roman alum, due to the presence of very finely divided ferric oxide, which is mechanically mixed in the mass. On crystallising the alum from hot water this is left behind in the form of a reddish deposit.

Another method for preparing alum has long been known, and is described by Agricola and Libavius. For this purpose shale is employed. This chiefly occurs in the Silurian and Devonian formations, and contains finely divided iron pyrites, distributed through a mass of bituminous shale. The shale is heaped together, and is either allowed to decompose slowly by exposure to the air, or it is roasted. In either case the pyrites is oxidised with formation of ferrous sulphate and free sulphuric acid, both of which act upon the clay, producing aluminium sulphate, which is then dissolved out with water. It has long been known that the ley thus obtained does not crystallise until an alkali has been added to it. Both Agricola and Libavius state that it was customary to add decomposed urine to the ley, in order, as the latter author remarks, to separate out the vitriol which is contained in solution. The alum thus prepared must have been chiefly ammonia-alum. This conclusion is corroborated by Künkel's remark, for we find that he states distinctly in his *Laboratorium Chymicum* that alum contains the volatile alkali. Instead of urine, potash was soon used, and Hoffmann, in 1722, explained why an alkali was added, and this explanation, namely, that the crude ley is unable to crystallise because it is too acid, and also because it contains a sulphurous impurity which has to be removed by the

addition of alkali, is the one which was accepted as correct until the end of the last century. At that time, and even up to a later date, it was not generally admitted that an alkali formed an essential constituent of the alum. Moreover, alum was often prepared without the addition of such an alkali, for in those days the existence of a potassium compound in a mineral such as aluminite was not known. Bergmann and Scheele, who were well aware that alum contained potash, considered it to be an impurity. Marggraf then showed that pure alumina and sulphuric acid only form an alum when an alkali is added, and hence Lavoisier concluded that two bases were contained in alum, viz., the alumina and the fixed alkali. These views were, however, not generally accepted until 1797, when Chaptal and Vauquelin showed that potash is an essential constituent of alum, the latter chemist proving, moreover, that this fixed alkali can be replaced by ammonia, and asserting that when aluminous minerals yield an alum on treatment with sulphuric acid it is a proof that these minerals contain potash.

The crude ley from the lixiviation of the burnt shale consists essentially of the sulphates of aluminium and iron. The longer the shale remains heaped up, and the longer the ley stands before it is further worked up, the smaller is the quantity of ferrous sulphate (green vitriol) which it contains, inasmuch as this salt is gradually converted by the oxygen of the air into ferric sulphate, which does not crystallise out with the alum. The solution is then evaporated down in order that the iron salt may be deposited, and the solution ultimately obtained, which has a specific gravity of 1.4, consists of aluminium sulphate, with a small quantity of ferric sulphate. In order to obtain alum from this solution a potassium salt is added, and as the double salt formed is difficultly soluble it separates out at once from the concentrated solution. Either potassium sulphate or chloride may be employed for this purpose; the first of course at once yields the alum together with ferrous potassium sulphate, which remains in the mother-liquor, a considerable quantity of potassium being thus lost. If potassium chloride be employed the alum is also at once precipitated; but aluminium chloride is found in solution. If, however, ferric sulphate is present, potassium sulphate is formed, and the readily soluble ferric chloride. Hence it is most economical to employ a mixture of the two potassium salts in different proportions, to be determined according to the con-

position of the ley. The crude potassium chloride from Stassfurt is now usually employed as the source of the potash. This substance is dissolved in a small quantity of hot water, and the solution added to the crude ley, and alum-meal is then obtained by well stirring the mixture until it is cold. The small crystals of which the meal consists are washed with a small quantity of cold water, the first wash-water being allowed to run into the boiling-down pans, and the last wash-water being employed for washing the crude alum. The purified meal is then dissolved in boiling water or by means of a current of steam, and the solution brought into large crystallising vats built of movable staves, bound together with iron hoops. In these the alum is deposited in the large crystals in which it is usually found in commerce.

Up to within recent years the chief quantity of alum made in England has been ammonia-alum, prepared according to Spence's method. For this purpose the black bituminous shale lying above the coal-measures is employed as the source of alumina. This is made into heaps about 15m. in height and slowly roasted. The mass, which when roasted has a light red colour and is brittle, is then brought into large covered pans, in which it is exposed to the action of sulphuric acid of specific gravity 1.35 for two days and heated to 110° by fires placed underneath the vessels. At the same time the vapours obtained by heating ammoniacal liquor from the gas-works in boilers is blown in. The volatile ammoniacal compounds contained in this liquor, such as the carbonate and sulphide, are converted by contact with the sulphuric acid into sulphate, and in order to decompose the remaining non-volatile ammonium salts lime is added to the residue in the boiler. In this process it is not necessary first to add the acid and then the ammonia; so long as sulphuric acid remains in excess the same action takes place, and the roasted silicate is decomposed if the ammonia be boiled in whilst the action of the sulphuric acid is going on. The solution of ammonia-alum is run out into cisterns, where it is stirred until cold in order to obtain small crystals of the alum-meal. This is then drained and brought into a funnel-shaped vessel, where steam is allowed to blow on it in such a manner that the whole of the steam is condensed and all the salt dissolved. In half an hour about four tons of alum-meal can thus be dissolved. The solution is allowed to settle in lead-lined cisterns, and then brought into crystallising vats and allowed to remain in them

for a week. The staves are then knocked away, and a cylindrical block of alum remains, which is allowed to stand another week. A hole is afterwards drilled into the bottom of the block, the mother liquor allowed to run out, and the mass broken up. Each vat yields three tons of large crystals, which frequently possess an amethystine tint resembling alum containing iron, although it is perfectly free from this impurity. This colour is doubtless due to organic compounds, being probably derived from a small quantity of aniline present in the gas-water.

Since the introduction of cheap potassium chloride from Stassfurt, ammonia-alum is no longer manufactured in England, potassium sulphate being manufactured by the action of sulphuric acid upon the natural potassium chloride in an ordinary salt-cake furnace.

Besides the methods already described, many other processes have been proposed for the manufacture of alum from aluminous shale, clay, slag from blast-furnaces, and other materials containing alumina. For a description of these processes the reader is referred to Prof. Hofmann's *Report on Chemical Industry*.

274 *Potassium-Alum*, $\text{Al}_2(\text{SO}_4)_3 + \text{K}_2\text{SO}_4 + 24\text{H}_2\text{O}$, is found in nature in feathery or mealy crusts or masses, as an efflorescence on alum-shale, and in volcanic districts, where it is formed by the action of sulphur dioxide and oxygen on trachyte and lava. In some places, as in the districts near Naples and in Sicily, alum is produced in sufficient quantity to render its manufacture possible, and a very pure alum is obtained from this source. Potash-alum has a specific gravity of 1.724 (Kopp); it crystallises in transparent regular octohedrons, which often exhibit the cube and dodecahedron faces; its solution possesses a sweet astringent taste, and has an acid reaction. 100 parts of water dissolve (Poggiale):

At	0°	10°	20°	30°	40°	50°
$\text{K}_2\text{Al}_2(\text{SO}_4)_4 + 24\text{H}_2\text{O}$	3.9	9.5	15.1	22.0	30.9	44.1 parts.

At	60°	70°	80°	90°	100°
$\text{K}_2\text{Al}_2(\text{SO}_4)_4 + 24\text{H}_2\text{O}$	66.6	90.7	134.5	209.3	357.5 parts.

It is insoluble in alcohol. On exposure to the air the surface becomes opaque and white. This is not, however, due to a loss of water, but is caused by the absorption of ammonia and the formation of a basic sulphate. When a crystal of alum is placed over sulphuric acid or heated to 61°, it loses 18 molecules of

water (Graham); at 92° it melts in its own water of crystallisation, and loses the whole of its water slowly at 100° , and quickly at a higher temperature with formation of what is known as burnt alum. This forms a porous mass, which dissolves slowly but completely in water. When alumina is fused with hydrogen potassium sulphate, an anhydrous alum is obtained which crystallises in small six-sided crystals, which remain behind when the fused mass is treated with hot water.

275 Neutral and Basic Alums. If an alkali be slowly added to an alum solution, a precipitate is thrown down which disappears on stirring, but after a further addition of the alkali it remains unaltered. The solution in which the precipitate just redissolves has a neutral reaction, and is termed in commerce neutral alum; it is employed in dyeing, as it readily gives up alumina to the colouring matter, and is free from iron, inasmuch as the alkali decomposes any iron sulphate which the liquid may contain. If this solution be allowed to evaporate at the ordinary temperature, a crystalline crust is deposited which contains the basic salt $Al_2(SO_4)_3 + Al_2(OH)_6$, together with potassium sulphate. If the solution be heated above 40° , common alum is formed; and a precipitate of $K_2SO_4 + Al_2SO_4(OH)_4$ is thrown down, this latter substance being identical in composition with alunite from Tolfa. When a solution of basic alum is heated in sealed tubes to 230° , this compound is also obtained in crystals (Mitscherlich). Solutions which contain a small quantity of basic alum yield, on spontaneous evaporation, cubical crystals. These were first observed by Sieffert in 1772, and obtained by him by boiling alum with milk of lime. This so-called cubic-alum has the same composition as common octohedral alum, and on heating the solution, to which a small quantity of alkali has been added, to a temperature above 100° , ordinary octohedral alum separates out. Roman alum obtained from alunite often occurs in commerce in cubical crystals.

When powdered alum is ignited with sugar or lamp-black and the mass allowed to cool in a closed vessel, a preparation is obtained which takes fire on exposure to the air. This spontaneous inflammability depends upon the fact that the preparation contains potassium sulphide in an extremely fine state of division, and that this oxidises so quickly on being brought into moist air that the particles are heated up to the point of ignition.

Rubidium and caesium also form alums which are very

difficultly soluble, and hence are employed, as has already been described, for the separation of these metals from potassium.

276 *Ammonium-Alum*, $\text{Al}_2(\text{SO}_4)_3 + (\text{NH}_4)_2\text{SO}_4 + 24\text{H}_2\text{O}$. This salt is very similar to potassium-alum. It has a specific gravity of 1.626, loses water on heating, and, on ignition, leaves a residue of pure alumina. One hundred parts of water dissolve (Poggiale):

$\text{Al}_2(\text{NH}_4)_2(\text{SO}_4)_4 + 24\text{H}_2\text{O}$	At	0°	10°	20°	30°	40°
		5.2	9.1	13.6	19.3	27.3 parts.
$\text{Al}_2(\text{NH}_4)_2(\text{SO}_4)_4 + 24\text{H}_2\text{O}$	At	50°	60°	70°	80°	90°
		36.5	51.5	72.0	103.0	187.8 422.0.

Commercial alum frequently contains both potassium and ammonium in varying proportions.

A hydroxylamine alum is also known,

Sodium-Alum, $\text{Al}_2(\text{SO}_4)_3 + \text{Na}_2\text{SO}_4 + 24\text{H}_2\text{O}$. It was formerly believed that aluminium sulphate does not form an alum with sulphate of soda, but this salt was prepared in the year 1816 by Zellner. Sodium alum is much more readily soluble in water than the other alums. Its specific gravity is 1.6. It effloresces in the air, and loses the whole of its water at a temperature of from 40° to 50°, leaving an easily soluble residue. It is not manufactured on the large scale, as on account of its solubility it is difficult to prepare in the pure state.

Thallium-Alum, $\text{Al}_2(\text{SO}_4)_3 + \text{Tl}_2\text{SO}_4 + 24\text{H}_2\text{O}$. The analogy of thallium to the alkali-metals is borne out by the fact that it forms an alum which crystallises in bright octohedrons or cubo-octohedrons.

Silver-Alum, $\text{Al}_2(\text{SO}_4)_3 + \text{Ag}_2\text{SO}_4 + 24\text{H}_2\text{O}$. The isomorphism of many silver salts with the corresponding salts of sodium connects this metal closely with those of the alkalis, and silver likewise forms an alum. This is obtained by heating a mixture of silver sulphate and aluminium sulphate, together with some water, in sealed tubes, until the silver sulphate is dissolved. On cooling, octohedral crystals are deposited. These are, however, decomposed into their constituents by water.¹

Besides the above-mentioned alums, a number of other alums are known, in which the aluminium is replaced by isomorphous metals, such as iron, manganese, and chromium. A peculiar nomenclature has arisen in the description of these compounds. If none of the isomorphous metals replace aluminium, as in the

¹ Church and Northcote, *Chem. News*, ix. 155.

above-mentioned alums, each is an aluminium-alum. The names, iron-alum, chromium-alum, and manganese-alum, on the other hand, are used, as a rule, to designate the potassium double sulphates of these metals. If potassium be replaced by other metals, then the names of both metals must be mentioned, as, for instance, ammonium-chrome-alum, and so forth.

Selenic acid also forms a series of alums, having the general formula, $M_2^{+7}(SeO_4)_3 \cdot M_2SO_4 + 24H_2O$.

277 *Aluminium Nitrate*, $Al_2(NO_3)_6$, is obtained by dissolving the hydroxide in nitric acid, and evaporating the solution with occasional addition of nitric acid. On cooling, the salt $Al_2(NO_3)_6 + 16H_2O$ separates out in very deliquescent prismatic needles. This salt decomposes at 150° , leaving a residue of pure alumina (Deville), and this reaction may be employed for the separation of aluminium from calcium and magnesium, metals whose nitrates do not decompose in this way. The solution of the normal nitrate is obtained by exactly precipitating a solution of lead nitrate with aluminium sulphate. This solution is used as a mordant in calico-printing with alizarine colours.

278 *Phosphates of Aluminium*. Normal aluminium orthophosphate, $Al_2(PO_4)_3$, is obtained as a gelatinous precipitate by adding a neutral solution of alumina to a solution of phosphate of soda. It is soluble in alkalis and mineral acids, but not in ammonia. If an acid solution of the salt be precipitated with ammonia, a basic salt, $3Al_2(OH)_3PO_4 + Al_2(OH)_6$, is thrown down; this, combined with nine molecules of water, forms the crystalline mineral wavellite. In addition to this, many other basic and double phosphates of aluminium occur in the mineral kingdom, of which the mineral turquoise or calaite, occurring in Persia and valued as a gem, is one of the most important. This is coloured of a greenish or bluish colour by copper, and is the basic salt $Al_2(PO_4)(OH)_3 + H_2O$. Most of the turquoise, not artificial, used in jewellery in former centuries as well as at the present time, and described in early works on mineralogy, is bone-turquoise or odontolite, a fossil bone or tooth coloured by phosphate of iron.

279 *Silicates of Aluminium*. It has already been stated that the various silicates of aluminium occur in combination with other silicates to form the chief constituents of the solid crust of the earth. The number of these compounds is extremely large, and only those can be mentioned in this work which possess a general interest.

Topaz, $\text{Al}_2\text{SiO}_4\text{Fe}_2$, occurs in granite, gneiss, and mica-schist in the form of rhombic prisms, which are transparent and usually colourless, or of a light- or dark-yellow colour. The finest topaz occurs in the Urals, Siberia, and Brazil. The common forms are not unfrequently employed for the manufacture of polishing powder instead of emery.

Beryl, $\text{Be}_3\text{Al}_2\text{Si}_6\text{O}_{18}$. The transparent green variety which owes its colour to chromium oxide is usually termed emerald. This mineral has already been described under beryllium.

Noble Garnet (MgFe) $_3\text{Al}_2\text{Si}_3\text{O}_{12}$. This, like the other members of the group of garnets, crystallises in the regular system, the dodecahedron being the most prominent form. The crystals are transparent, and are coloured, according to the quantity of iron which they contain, from a pale yellow up to a dark red tint.

Lapis lazuli is a double silicate of aluminium and sodium containing sulphur. It has long been valued for its splendid blue colour. Its constitution is, however, as yet unknown. It crystallises in dodecahedrons, but usually occurs in the massive condition, and is found in Central Asia, Siberia, Persia, China, &c. It is largely used for making vases and for inlaying ornamental furniture, and the powdered lapis lazuli forms the valuable paint termed ultramarine. This substance is, however, now artificially prepared on the large scale.

ULTRAMARINE.

280 Tessaert observed in 1814 the formation of a blue colour in one of his black-ash furnaces at the celebrated glass-works of Saint Gobain, and Vauquelin showed that this colour is identical with lapis lazuli. In 1824 a prize was offered in France for the discovery of a practical method of manufacturing this colour, and this problem was successfully solved in the year 1828 simultaneously by Guimet¹ and Christian Gmelin, the latter of whom published the process in the year 1828.²

Since this date the ultramarine industry has largely increased. The chief quantity of the substance is manufactured in Germany, where, in the year 1872, 6,579,308 kilos. were produced, whilst the total production of the world amounted in the same year to 8,585,308 kilos. In the year 1829 the price of artificial ultramarine was £12 per lb., whereas now it is sold at less than

¹ *Ann. de Chim.* xlv. 431.

² *Quart. Journ. Science*, li. 216.

6d. per lb. Different varieties of ultramarine occur in commerce; these, however, can be divided into two classes.

Ultramarine poor in Silica is obtained by heating a mixture of soft clay with Glauber salt, charcoal, soda, and sulphur in crucibles placed in a furnace. Instead of charcoal, tar or resin is sometimes employed. In this way a colourless compound is first produced, termed white ultramarine. This, however, soon becomes of a green colour. The green ultramarine thus obtained, which is also used as a colour, is then mixed with sulphur and heated. The sulphur takes fire and is allowed to burn in the air, when the product becomes of a fine blue colour. *Ultramarine rich in Silica* is generally obtained by heating a pure clay with finely ground white-sand, sulphur, and resin in a muffle-furnace, when a blue product is at once obtained which, according to the quantity of silica which has been added, retains more or less of a red tinge. The different kinds of both green and blue ultramarine are then finely ground and washed with water, and thus the several marketable varieties are obtained. A violet and a red variety of ultramarine have lately been prepared. The following table gives the composition of some different ultramarines:—

	Green.	Blue.	
		Poor in Silica.	Rich in Silica.
SiO ₂	38.52	37.90	40.77
Al ₂ O ₃	28.94	29.30	28.74
Na ₂ O	23.68	22.60	18.54
S	8.30	7.86	13.58
Earthy residue	1.94	2.36	3.61
	100.38	100.02	100.24

It has already been stated that the chemical constitution of ultramarine is, as yet, unknown. The sulphur present is, however, contained in two conditions. Acids readily decompose all the different kinds of ultramarine, gelatinous silica and finely divided sulphur being deposited and sulphuretted hydrogen evolved. The ultramarine which is poor in silica is decolourised by the action of a cold solution of alum, whilst the ultramarines rich in silica withstand the action of this salt, and the more completely the more silica they contain. Hence these latter varieties are employed in cases in which the colouring

matter comes in contact with aluminium salts, as for instance in the blueing of paper and in calico-printing. The different kinds of ultramarine are very largely employed in the arts, for water-colours, as an oil-paint, and for paper-staining.

Silver-Ultramarine. When blue ultramarine is heated with a solution of silver nitrate, the sodium is replaced by silver, and a yellow powder is thus obtained which under the microscope is seen in the form of dark lemon-yellow transparent particles. It is easily decomposed by acids with separation of silica and sulphide of silver, but without evolution of sulphuretted hydrogen. If silver ultramarine be heated with a solution of potassium chloride the silver is replaced by potassium, and in this way blue potassium-ultramarine is obtained, a substance which has hitherto not been prepared directly (Heumann). Ultramarines containing selenium and tellurium in place of sulphur have recently been prepared.

Aluminium Sulphide, Al_2S_3 . Aluminium combines with sulphur at a red-heat to form a dark mass, which assumes a metallic lustre under the burnisher. It is decomposed by water into sulphuretted hydrogen and aluminium hydroxide.

DETECTION AND ESTIMATION OF ALUMINIUM.

281 Aluminium compounds do not impart any colour to the non-luminous gas-flame. The spark-spectrum of aluminium has been mapped by Thalén, Kirchhoff, and Lecoq de Boisbaudran. It contains a large number of bright lines lying close together, of which the most important in the red are 6423, and 6425, and in the blue 4661, and 4662. The aluminium bands seen in the ultra-violet are extremely characteristic. These are contained in the invisible and highly refrangible portions of the spectrum which are only seen when the rays are allowed to fall on a fluorescent substance.¹ Aluminium occurs almost always combined with oxygen. Most of these compounds are insoluble in water; many of them, however, are decomposed by hydrochloric acid, the alumina entering into solution. Those compounds which withstand the action of acids are decomposed by fusion with sodium carbonate and treatment of the fused mass with hydrochloric acid. Corundum, spinelle, and some other minerals are not, however, decomposed in this way: the best method for

¹ Stokes, "On the Long Spectrum of the Electric Arc," *Phil. Trans.* 1862, p. 599.

obtaining the aluminium in solution is to fuse these substances with hydrogen potassium sulphate.

Aluminium can readily be separated from all other metals. It is not precipitated from its acid solutions by sulphuretted hydrogen, whereas it is completely thrown down by ammonia and sulphide of ammonium, and thus can be readily separated from the metals of the alkalis and alkaline earths. It is distinguished from most of the metals precipitable by sulphide of ammonium, inasmuch as its hydroxide is soluble in caustic alkalis. This property it possesses in common with the hydroxides of zinc, chromium, and beryllium. The first of these metals is precipitated in the alkaline solution by sulphuretted hydrogen, whereas chromium hydroxide is only soluble in the cold, and is precipitated on boiling. If to the solution from which the zinc and chromium have thus been separated, hydrochloric acid and then ammonia be added, the aluminium is precipitated. This precipitate may, however, still contain beryllium hydroxide, which must be dissolved by digesting it with carbonate of ammonia. (See p. 233).

For quantitative estimation, aluminium is precipitated as hydroxide, and this converted into the oxide by ignition.

The atomic weight of aluminium was first determined by Berzelius in 1812, who found that 100 parts of the anhydrous chloride yield 29·934 parts of pure alumina, and from this the atomic weight of 27·2 is obtained.¹ Tissier² found the number 27·4 by the conversion of the metal into the oxide, and Dumas³ obtained the same number by the analysis of the chloride.

GLASS, PORCELAIN, AND EARTHENWARE.

282 The naturally-occurring silicates are almost all of them crystalline, and are thereby distinguished from those produced artificially, which are usually amorphous. Amongst these latter may be classed glass, porcelain, and the various kinds of pottery.

¹ *Pogg. Ann.* viii. 187.

² *Compt. Rend.* xlvi. 1105.

³ *Ann. Chim. Phys.* lv. 129.

GLASS.

The manufacture of glass appears to have been discovered by the Egyptians, although the ancients themselves attributed the discovery of glass-making to the Phœnicians. Glass vessels of various sizes, both colourless and coloured, have been found in Egyptian tombs which belong to an age prior to that in which the Phœnicians occupied themselves with glass-making. Indeed the latter nation appear rather to have been engaged in exporting the glass made in Egypt, and especially at Thebes, into different parts of the ancient world, than to have established any original manufacture of their own. In the tombs of Beni Hassan near Thebes, which were built more than 2000 years B.C., we find paintings representing Egyptians carrying on the processes of glass-blowing. From these, as well as from the glass vessels which are found in the tombs, it appears that the Egyptians were not only acquainted with the art of glass-making and of working in glass, but likewise with that of cutting and colouring glass by which they imitated precious stones. Thus an urn has been found made of white glass and ornamented with patterns in white and in light- and dark-blue glass showing Thoutmosis' ring, who reigned in the 17th century B.C.; as also a moulded glass bead bearing a hieroglyphical legend and a king's name who lived at this period impressed upon it in moulded characters.¹

Aristophanes is the first Greek author who mentions glass (*ὑάλος*), and in his *Clouds* he refers to a glass lens which was used as a burning-glass. Amongst Latin authors, Cicero is the first to mention Egyptian glass, and we find that at the time of Augustus the Egyptian glass was highly valued in Rome, so much so that when this emperor subdued Egypt (29 B.C.), a portion of the tribute was ordered to be paid in glass; this material afterwards being so highly valued by the Romans that Aurelius levied an import duty upon glass.

Glass-works were established in Italy, France, and Spain at an early date. These glass-houses, however, only manufactured common objects for every-day use, and it was not until after the introduction of Egyptian workmen to Rome that artistic

¹ For further information see Sir Gardner Wilkinson, *The Manners and Customs of the Ancient Egyptians*, vol. iii. p. 88. edit. 1837.

glass-ware was made in Europe. This took place during the reign of Tiberius, and the art made such rapid progress that in the time of Nero, Roman glass rivalled in every respect the original Egyptian manufacture. According to Pliny, Egyptian soda and sand were employed in the manufacture of glass, and he remarks that in India rock-crystal was used for this purpose, and that in his time the material which was most highly valued for making glass was that which approached most nearly to this mineral. This is readily understood when we remember that most of the materials used for the manufacture of glass contain metallic oxides, which produce a colouring effect upon the mass, so that it is in fact easier to produce coloured than colourless glass. And even in those early days we find that manganese was employed as a decolourizing agent. Pliny moreover specially mentions the preparation of coloured glass, whilst analyses of antique glass show that the materials employed to produce the colours in those days are identical with those which are at present in use.

After the fall of the Western Empire the glass manufacture followed Constantine to Byzantium, and for five centuries the Eastern capital became a renowned seat of the glass manufacture. On the decay of the Empire of the East, the glass-makers wandered to various parts of Europe, many being attracted to the Venetian Republic. Here glassmaking greatly flourished. As a protection against fire, as it is said, the manufacture of glass was removed in the year 1289 from the city of Venice to the adjacent Island of Murano, and here during the 16th and 17th centuries the Venetian glass-manufacture attained its highest development, the elaborate productions of Venetian art becoming famous throughout the civilised world. No less than 8,000 men were, it is stated, employed at that time in this manufacture, and so important did this branch of Venetian trade become, that strict laws were promulgated to prevent the secrets of glass-making from becoming known to foreign workmen, the supervision of the glass-houses being confided to the chief of the Council of Ten. The Venetian glass-industry received, however, a check in the 17th century, from which it has only in recent years recovered.

283 In the early Middle Ages an independent manufacture of glass arose in Germany, and glass-painting is entirely of German origin; the manufacture of glass-mirrors appears also to be a German invention. At first the glass was coated with a plate

of metal, and it was not until the 15th century that the present process was introduced. In addition to table-glass and window-glass, artificial gems, glass rings, and other objects of art were manufactured in Germany. Agricola in his treatise *De re Metallica*, published in the year 1530, gives the first drawing of the interior construction of a glass-furnace, and in this work as well as in Mathesius' *Sarepta or Bergpostill* (1564), we find explicit and interesting directions concerning the manufacture of glass as carried on in Venice, Germany, and Bohemia. In the last-named country the glass-industry began to flourish in the 16th century, the purity of the materials occurring there enabling manufacturers to produce the colourless glass for which the Bohemian glass-houses have long been famous and in which they still excel. When the Venetian glass-manufacture fell into decay, Bohemian glass replaced Venetian, but in time the Bohemian manufacture again suffered a relapse, owing to the heavy import duties which were levied upon glass-wares as well as to the fact that other governments held out inducements to the Bohemian workmen to settle in foreign countries; and, like the Venetian manufacture, it is only in recent years that the Bohemian glass-industry has recovered its original position.

In the meantime many of the German princes patronised the glassmakers, and each became celebrated for some peculiar manufacture. Thus a glass-house at Potsdam was well known for its manufacture of ruby glass. This glass-house was established under the direction of Joh. Kunkel, and in 1685 he published the first edition of his *Ars Vitruvia Experimentalis*, in which he gives a translation of the collection of receipts published at Florence by Antonius Neri in 1612, and adds to them remarks of his own and those of E. Merret.

Glass-works were also set up in France at an early date, but it was not until the 18th century, when workmen were introduced from Germany, that a pure kind of French glass-ware was made. Plate- or mirror-glass was first prepared in England, but the method of manufacture was greatly improved by De Nelhou, who in 1688 erected a glass-works at Paris. This was afterwards removed to St. Gobain, where it soon became and still remains the most important plate-glass works in the world.

The first manufacture of glass which we hear of in England is that of window-glass established in the 15th century. The product cannot, however, have been very good, for in an old deed made in 1439 by the Countess of Warwick and a glazier

of Westminster named Prudde, it is distinctly stipulated that no English window-glass is to be used. In the reign of Elizabeth, French artists were brought to London, and these carried on their trade of making window-glass at Crutched Friars in 1557, whilst flint-glass was first manufactured at a glass-house at Savoy House in the Strand. Mirror-glass, used for looking-glasses, coach-windows and similar purposes, was manufactured at Lambeth by Venetian workmen brought over in 1670 by the Duke of Buckingham. The first large plate-glass works were established in 1771 at St. Helens under the name of the Ravenshead or the British Plate-Glass Company, and this company continues to flourish up to the present time.

The glass industry was introduced into Russia in the 17th and 18th centuries by German and Bohemian workmen; and in the United States the same manufacture appears to have been established by Robert Hewes, a citizen of Boston, who erected a glass-house in the forest which existed in New Hampshire. The manufacture of Mr. Hewes does not seem to have been successful, and in 1800 another attempt was made to establish a glass-house at Boston, which also failed, until a German of the name of Lint took charge of the works in 1803, and the State of Massachusetts agreed to pay a bounty on all glass manufactured by him.

284 *Composition of Glass.* Glass is an amorphous mixture of various silicates, especially of those of the alkalis and alkaline earths, formed by the fusion of the ingredients. Glass differs from any of the simple silicates which compose it by being nearly insoluble in water and in acids, as well as by being non-crystalline; for whilst the silicates of the alkalis yield a non-crystalline mass on cooling from fusion, which is soluble in water, the silicates of the alkaline-earth metals, on the other hand, yield, after fusion, a distinctly crystalline solid readily attacked by acids. At high temperatures glass fuses to a thin mobile liquid, and on cooling this passes through all gradations of viscosity until the solid state is reached. This property of glass to pass gradually from the liquid to the solid condition is one which is peculiarly characteristic of the substance, and it is this which caused Pliny to consider glass as the most plastic of substances.

Owing to the immense number of its applications to the purposes of every-day life, the manufacture of glass has greatly contributed to the progress of civilization, whilst from a scientific

point of view the value of glass can scarcely be overrated, as the sciences of chemistry and physics could scarcely exist were it not for this most useful material.

285 The several kinds of glass may be divided according to their composition into four chief varieties :

I. *Bohemian Glass*. This is a silicate of potash and lime. It is very difficultly fusible, and of all glass it is that which is least acted upon by chemical reagents.

II. *Window- or Crown-Glass*. This is a silicate of soda and lime. It is more fusible but harder than the preceding, and possesses the faint blue colour characteristic of soda-glass ; it is more readily acted upon by acids than Bohemian glass.

III. *Bottle-Glass or Common Green Glass* is a silicate of soda and lime, together with alumina and oxide of iron, and it is to this latter oxide, present as impurity in the cheap materials employed, that the mass owes its green colour. The alkaline silicates are contained in bottle-glass in smaller quantity than in the other varieties of glass, and the colour varies from a darker to a lighter green or brown according to the care with which the materials have been selected. It is harder and more infusible than soda-lime glass, but it is easily attacked by acids.

IV. *Flint-Glass or Crystal, and Strass*. This glass is a potash-lead silicate. It is characterized by its high specific gravity, bright lustre, and great refracting power. It is the most fusible variety of glass, and is easily attacked by chemical reagents. Crystal is a pure flint-glass used for optical purposes. Strass is a flint-glass, named after the discoverer, very rich in lead, and possessing a very high refracting power ; it forms the basis of the artificial gems and precious stones known as *paste*.

The following table shows the composition of samples of the different kinds of glass :—

Description of Glass.	SiO ₂	K ₂ O.	Na ₂ O.	CaO.	MgO.	PbO.	Al ₂ O ₃ .	Fe ₂ O ₃ .	Analyst.
I. BOHEMIAN GLASS—									
Old goblet	69.40	11.80	—	9.20	—	—	9.60		Dumas. Berthier. Péligot. Rowney.
Drinking glass	71.70	12.70	2.60	10.30	—	—	0.90		
Mirror glass	76.00	15.60	—	8.00	—	—	1.00		
Combustion tube	73.13	11.49	3.07	10.43	0.26	—	0.89		
II. CROWN, WINDOW, & PLATE-GLASS—									
Old Egyptian glass	72.30	—	20.83	5.17	—	—	1.19	0.59	Benrath.
Roman bottle	70.66	—	17.17	8.38	—	—	2.25	1.24	
German window-glass	71.56	—	12.97	13.27	—	—	1.29		" "
English window-glass	70.71	—	13.25	13.38	—	—	1.92		
French window-glass... ..	71.90	—	13.10	13.60	—	—	1.40		Péligot. Benrath.
German hollow glass... ..	78.39	—	13.91	7.10	—	—	0.60		
French hollow glass	72.00	—	17.10	6.50	—	—	4.50		Berthier. Cowper.
English crown-glass	71.40	—	15.00	12.40	—	—	0.60		
German crown-glass	73.11	—	13.00	13.24	—	—	0.83		Benrath. Péligot.
Plate glass from St. Gobin	73.00	—	11.50	15.50	—	—	—		
English plate-glass	77.90	1.72	12.53	4.85	—	—	3.59		Mayer and Brazier. Benrath. Berthier.
German plate-glass	78.75	—	13.00	6.50	—	—	1.75		
Venetian plate-glass	68.60	6.90	8.10	11.00	2.1	—	1.5		
III. BOTTLE-GLASS—									
German	65.57	2.72	4.86	20.42	—	—	3.34	2.81	Schuler.
French	59.60	3.20		18.00	7.00	—	6.30	4.40	Berthier.
IV. FLINT-GLASS—									
English flint-glass	51.40	9.40	—	—	—	37.40	2.00		Berthier. Benrath.
French " "	50.18	11.22	—	—	—	38.11	—	0.44	
Heavy optical glass	44.30	11.75	—	—	—	43.05	0.50	0.12	Faraday.
Strass	38.10	7.90	—	—	—	53.00	1.00		Donnalt-Wieland.

286 The materials used in the glass manufacture are, in the first place, silica, which is contained in all forms of glass. This substance is added in the form of white sand, ignited flint, or quartz. For the common kinds of glass common sand is used. The second important ingredient is the alkali, and this is added in the form of purified potashes; whilst the alkali used for the better kinds of soda-glass is added in the form of refined soda-ash. For the commoner sorts of glass sodium sulphate, or salt-cake, is now largely employed instead of soda-ash; this being transformed into sodium silicate by the silica, in the presence of carbon, with evolution of sulphur dioxide.

The materials employed for the formation of the other constituent of glass, viz., calcium silicate, are, according to the kind of glass needed, calc-spar, marble, chalk, or common limestone. In the manufacture of lead-glass red-lead is employed, and for the common varieties white-lead or litharge is sometimes used.

The less iron is contained in the materials used, the whiter and less coloured will be the glass. It is, however, almost impossible to obtain materials perfectly free from iron oxide, and, in consequence of this, a substance is generally added for the purpose of oxidizing the ferrous oxide to ferric oxide. The former oxide, even in small quantities, imparts to glass a deep-green tint, whereas the latter gives to the glass a light-yellow colour, and this is scarcely visible when the ferric oxide is present in small quantities. The decolorizing substances added for this purpose likewise serve to oxidize the carbon which is frequently present in the mass, and which imparts to the glass a deep-yellow or brown tint. Manganese dioxide (pyrolusite), arsenic trioxide, and saltpetre are used as decolorizing agents in the manufacture of lime-glass, whilst red-lead is employed for the same purpose in the manufacture of flint-glass. In former times manganese dioxide (pyrolusite) was exclusively used for this purpose. Indeed the Romans were acquainted with this property of manganese dioxide (see Manganese), and on account of its detergent qualities it was in later times called *sapo vitriariorum*, or glass-maker's soap. The decolorizing action of manganese dioxide upon glass not only depends upon the fact that it oxidizes the iron from ferrous to ferric oxide, but also that the manganese itself imparts to the glass a violet tint, and this being a colour complementary to the green, produced by ferrous salt, assists in the decolorization.

287 (1.) *Bohemian Glass* is made from pure powdered quartz and purified potashes, and is distinguished by its colourless character, which approaches that of rock-crystal itself. In consequence of this property it has long been highly esteemed, and Bohemia is the seat of a wide-spread industry, which, however, has somewhat declined since the general introduction of flint-glass. Bohemian glass serves for the preparation of chemical apparatus, and especially of combustion-tubes, which withstand a high temperature without softening.

(2.) *Window-, Crown-, or Plate-Glass*. From the preceding table it is seen that the glass of ancient Egypt possesses a very similar constitution to that which is now largely manufactured for the above purposes, and the Egyptians appear to have employed for the manufacture the naturally occurring carbonate of soda, or trona, which occurs in Upper Egypt. In Europe, and especially in France, kelp, or, at any rate, carbonate of soda obtained from kelp, was originally employed for glass-making; but this source of soda was replaced in England in the year 1831 by soda-ash, made by Leblanc's process. Laxmann in 1764 had already tried to replace the carbonate by the native sulphate occurring in the Siberian salt-lakes, and these experiments were continued in 1803 by Baader, who succeeded in replacing soda-ash by salt-cake in the manufacture of common glass; but it is only since 1856, when Pérouze found a simple method of obtaining the sulphate free from iron, that the latter has almost entirely superseded the more expensive soda-ash. The whole of the sulphur contained in the salt-cake is evolved as sulphur dioxide, and this escapes into the air, no practical process having, as yet, been suggested by which this gas can be condensed and utilized.

(3.) *Common Bottle-Glass or Green Glass*. Figures of glass-blowers plying their trade have been found in the Theban tombs of Beni Hassan, where the workmen are represented as using blow-pipes, and other tools similar to those which are now employed, whilst the bottles, and other products of the glass-blower's art (shown in the paintings) are not unlike similar objects of our own day. Bottles have also been discovered in the Theban tombs inscribed with Chinese characters. May not this fact point to a possible connection between Egypt and the still older monarchies of the far East? In vine-growing France the necessity for glass wine-bottles soon became felt, and a glass-bottle works was established so early as the year 1290 by

Leempoel, at Quiquengrogne, near La Chapelle, which is flourishing at the present day.

Bottle- or green glass is the commonest kind of glassware. The materials employed for its preparation are common coloured sand, the residual alkaline- and lime-salts from gas-works, soap-works, and alkali-works; common-salt, salt-cake, and ashes from fires of wood or charcoal; clay, basalt, and other rocks containing felspar.

The first essential of a wine-bottle is that it shall be strong, and that it shall not be attacked by the acids contained in wine. This last property depends upon the composition of the glass, for if it does not contain a sufficient quantity of silica, the glass is apt to be attacked by acids. The common, half-white blown-glass, stands, both in its composition and in its mode of preparation, between green bottle-glass and the pure white-blown glass, and the materials for its preparation must be free from iron. All the glass has, however, more or less of a green tint. In England common medicine bottles, as well as the large stoppered bottles, known as Winchester quarts, are tinted a light blue colour by the addition of oxide of cobalt.

288 (4.) *Flint-Glass or Crystal*. This glass contains lead oxide as its characteristic ingredient, and hence is frequently termed lead-glass. The name flint-glass was given to this product because burnt and ground flints were originally used as a source of silica. It is usually supposed that the manufacture of this glass was first carried on in England, and at the present day the article is a characteristic product of the English glass-house. It appears, however, that flint-glass was known to Neri, who describes it as by far the most beautiful glass, and in Kunkel's translation he says: "Lead-glass is not in use amongst our glass-makers on account of its great brittleness." At any rate lead-glass was made in England about the year 1635, and its manufacture was carried on by means of coal, which was first employed as fuel in the glass-houses in that year in place of charcoal. The carbonaceous smoke of the burning coal imparted to the ordinary glass a yellow colour, but this difficulty was overcome by the use of covered crucibles instead of the open ones formerly used (see Figs. 116 and 117). The drawback to the use of such crucibles was that they did not attain a sufficiently high temperature to bring the "metal," as the molten glass is technically called, into a condition of perfect fluidity. Under these circumstances a more readily fusible mass was

obtained by simply adding a larger quantity of potash. The quality of the glass was, however, thereby deteriorated, inasmuch as it was readily attacked by water. In order to remedy this evil a substance must be added which, whilst serving to render the glass more fusible, does not at the same time, like an excess of potash, render it soluble in water. Lead oxide was found to answer these conditions admirably.

Flint-glass possesses a higher specific gravity and refractive power, as well as a higher lustre, than the other kinds of glass. It is, however, more easily attacked by acids and alkalis.

Heavy optical-glass or *crystal* belongs to this class. *Strass* contains a larger quantity of lead oxide, and has, therefore, a greater refractive power, and is used for the purpose of making artificial gems. Several other kinds of glass may be classed as belonging to this group. Thus, for instance, those in which thallium, barium, and zinc replaces the lead; these also possess a high lustre, and are highly refractive. It has been proposed to use thallium glass for optical purposes.

THE MANUFACTURE OF GLASS.

289 The materials employed for the manufacture of the glass are first fritted together in melting-pots. These pots require great care in their preparation and are made of the most refractory kind of fire-clay, such as that found at Stourbridge. When

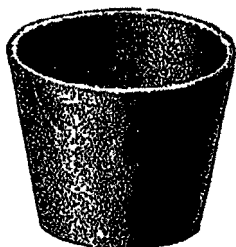

FIG. 116.

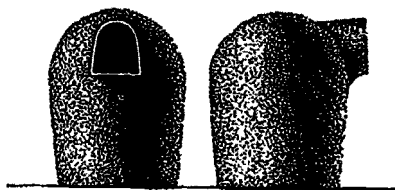

FIG. 117.

charcoal or gas is used as fuel the pots are open; when, however, coal is employed, and especially in flint-glass making, the pots are hooded or covered at the top, having a mouth in front like a muffle as seen in Fig. 117. The melting-furnace is built

of sandstone or of moulded blocks made of the purest fire-clay. The construction of the oldest form of glass-furnace as used in the time of Agricola, is shown in Fig. 118. It is hemispherical

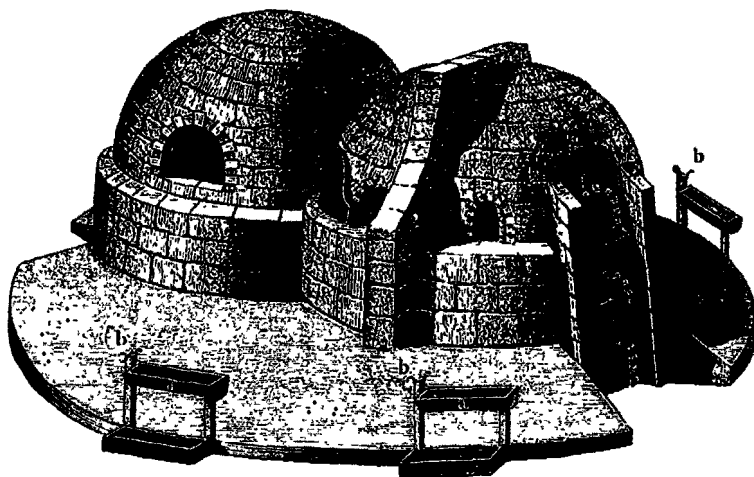

FIG. 118.

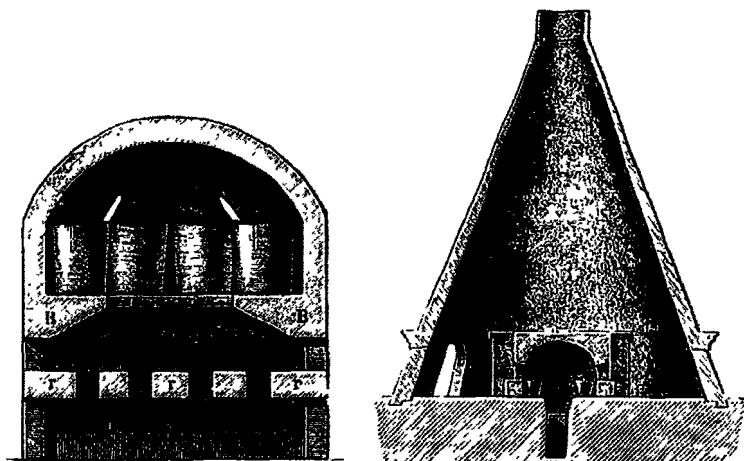

FIG. 119.

FIG. 120.

and is heated by a wood-fire placed in the lowest opening; the second opening gives access to the melting-pot, whilst the upper space serves as the annealing oven. The older glass-houses are

usually built in the form of a truncated cone, open at the top, from 60 to 80 feet in height, and from 40 to 50 feet in diameter at the base, the centre of the area being used for the melting-furnace, capable of holding from 5 to 10 glass-pots or crucibles for melting the materials. In the earliest glass-furnaces wood was employed as a fuel. This was gradually replaced by coal, and this change was naturally accompanied by an alteration in the form of the furnace. The small Bohemian furnace, where

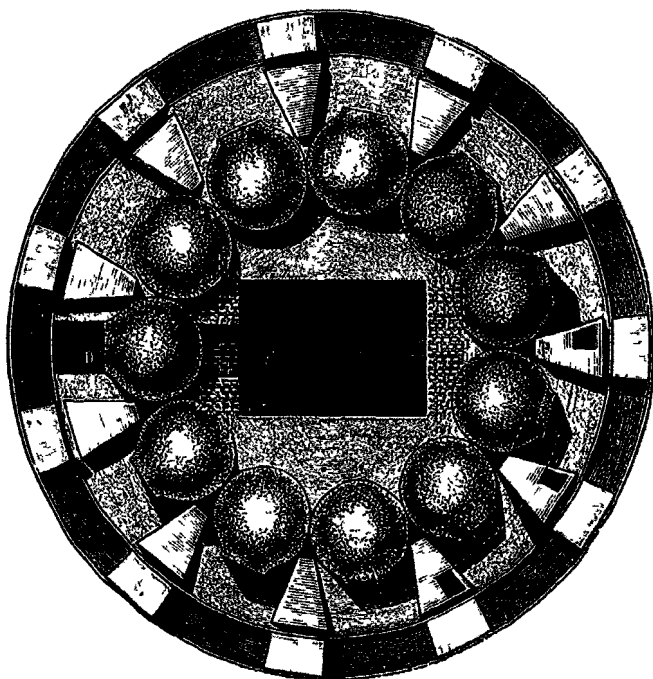

FIG. 121.

wood is employed as a fuel, shown in Fig. 119, was formerly common in Germany. In order to insure complete combustion and to bring about a sufficiently high temperature when the fuel used is coal, the arrangement shown in Fig. 120 is made use of, the whole of the furnace being inclosed in a conical chimney. Figs. 121 and 122 show the construction of a modern English flint-glass furnace in plan and in vertical section. Ten large glass-pots are placed round the walls of the furnace, with their

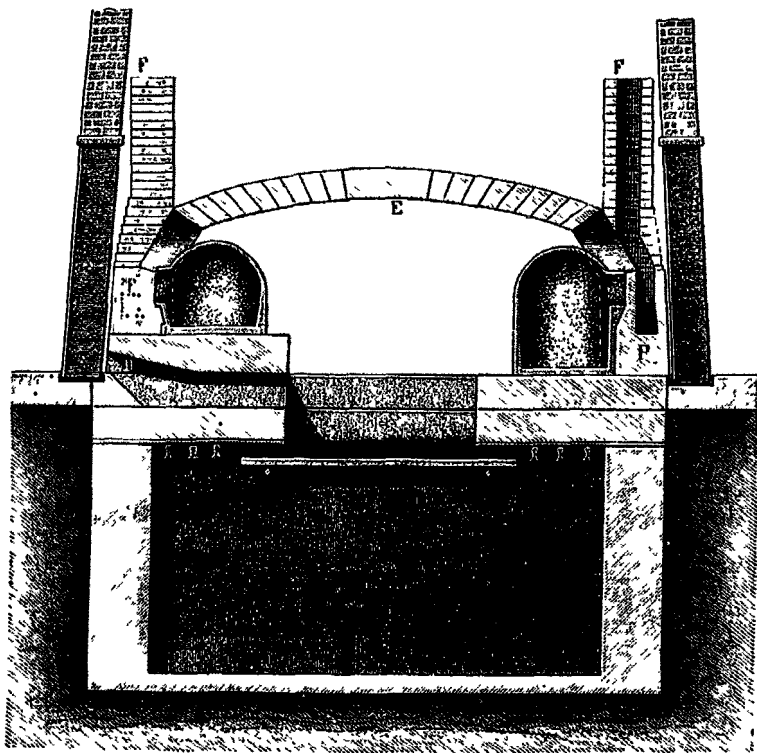

FIG. 122.

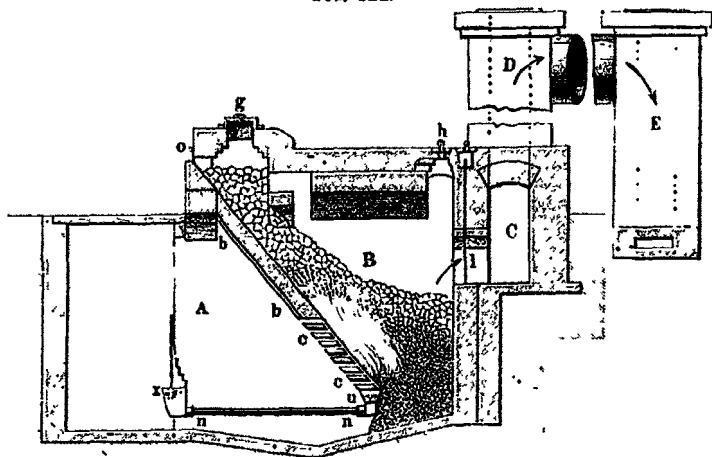

FIG. 123.

mouths towards the outside, opposite corresponding holes in the external wall of the furnace, so that the molten glass can be readily withdrawn. A small pot is placed above the firing-hole *D*. The grate for the coal fire is situated in the centre of the

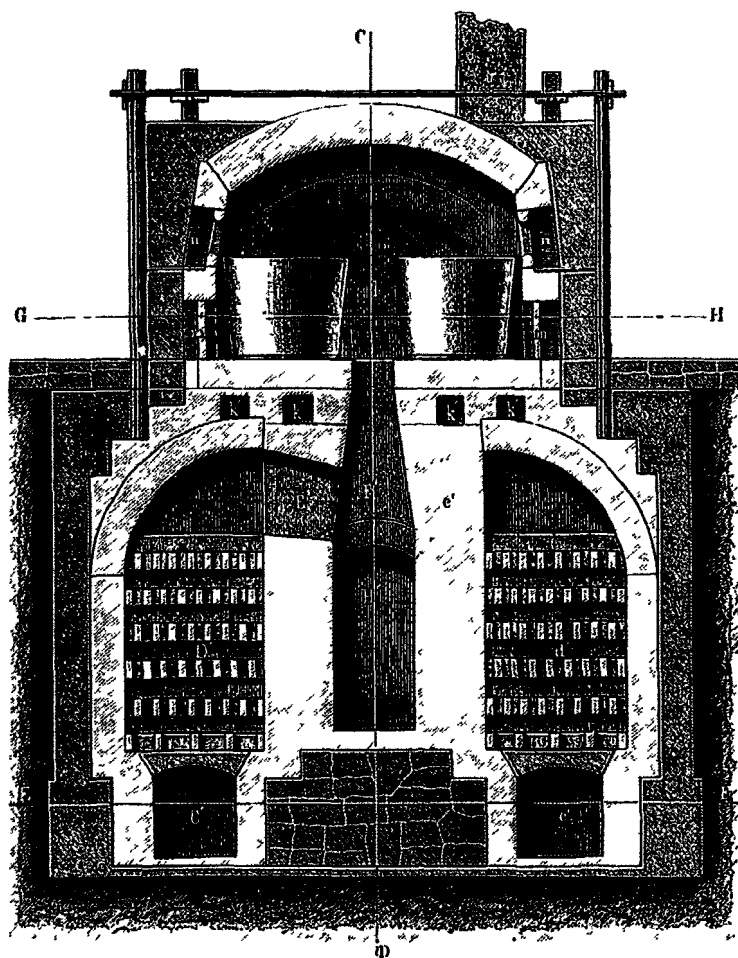

FIG 121.

furnace and the flames striking on the arch or crown *E* (Fig. 122) play round each pot and find their way through the flues (*F*) in the pillars into the common chimney.

Amongst modern glass-furnaces that invented by Siemens is the most successful. Fig. 123 shows the gas generator, which is situated at some distance from the melting-furnace. In this the coal falls down through the opening (*g*) on to the inclined plane (*b b*), whence it passes on to the inclined bars (*c c*) of the

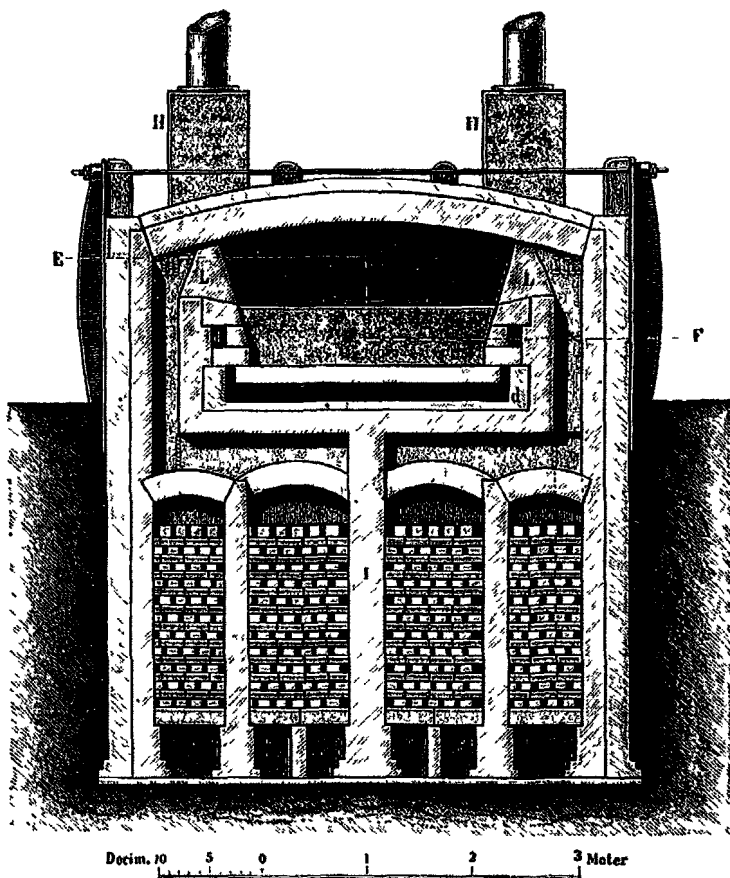

FIG. 125.

furnace. Here an incomplete combustion takes place and the coal lying above the grate undergoes dry distillation; the gases pass through the flues (*C*) (*D*) and (*E*), and are led into the melting-furnace, the construction of which is seen in Fig. 124. The gas passes through the flue (*C*) where it is heated in the

regenerator (D'), whilst the air necessary for the combustion of the gas is allowed to enter through the air-ports (k' k')

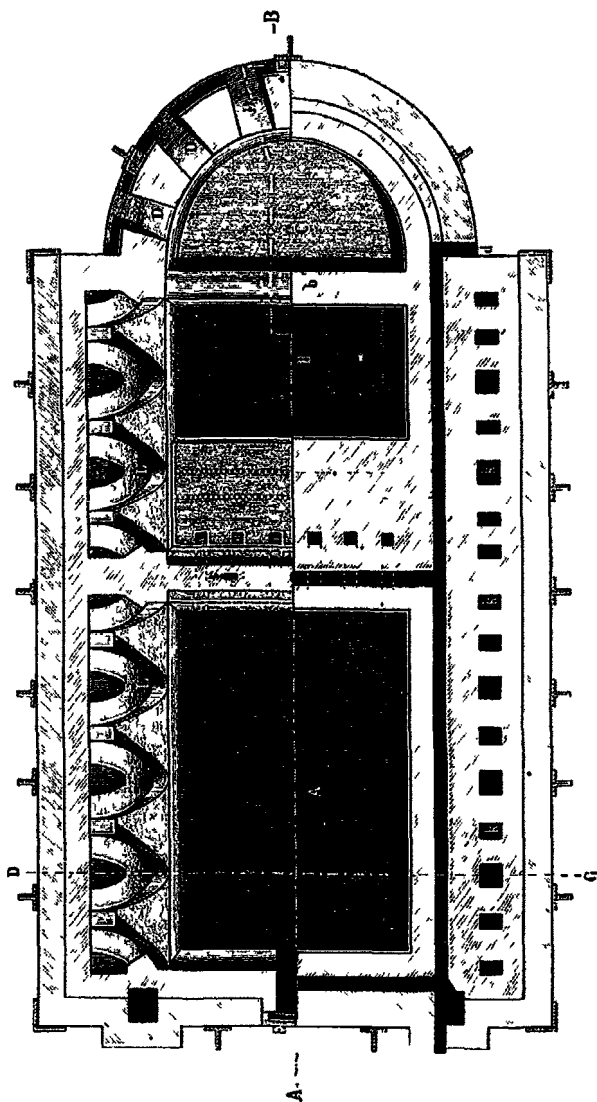

FIG. 126.

Fig. 125 shows a vertical cross section, Fig. 126 a horizontal section, and Fig. 127 a vertical longitudinal section of the most

improved form of a Siemens glass-melting furnace. This furnace resembles the one last described, in having the regenerative arrangement for recovering the waste heat as shown at (D'd') Fig. 124, but is remarkable for an improved method of construction and mode of working, the glass being placed in *tanks* instead of in *pots*. In the older forms of glass-furnace the materials are first charged into the glass-pots, then fritted and melted down and worked out completely, after which the pots are re-charged and the process repeated. Hence, a considerable loss of time and waste of fuel takes place through the intermittent nature of the work. Dr. Siemens' improvement has for its object the rendering of the process of glass-making a continuous and more uniform one. It consists of an arrangement of tanks (A), (B), (C), Fig. 127, of which (A) serves to receive the raw materials and in which they are fritted together and afterwards fused. From (A) the liquid "metal" flows into (B), the clarifying compartment, whence it again passes into (C), the working compartment, from which it can be withdrawn by the workmen in the usual manner through the doors (D, D). The compartment (A) is fed with raw materials through the charge-aperture (E) at the back of the furnace. This compartment (A) is separated from the tank (B) by a division wall (F), in which a series of passages are formed, one of which is seen at (a). Through these passages the melted glass flows, and from (B) it passes to the tank (C) through the passages (b) in the division wall (G). The sides and bottom of the tank are honeycombed with air-passages (d d d) through which cold air is caused to circulate by the draught produced in the chimney (H), and thus the tank-walls are maintained in a cool condition so as to enable them better to withstand any injurious action of the melted glass. The gas-ports are shown at (k k), and the heated air issues from corresponding openings passing in diverse directions over the upper edges of the wall. By this means an effectual intermixture of the combustible gas and the heated air is produced, and the air is prevented from coming into immediate contact with the surface of the melted glass in the tanks. By arranging the gas- and air-ports along the sides of the tanks the temperature in the different parts of the furnace can be regulated according to the various stages of the preparation of the glass in the several compartments.

The materials required for the formation of the glass are, if possible, always mixed with broken glass of the same kind, technically termed "cullet," for the purpose of increasing the

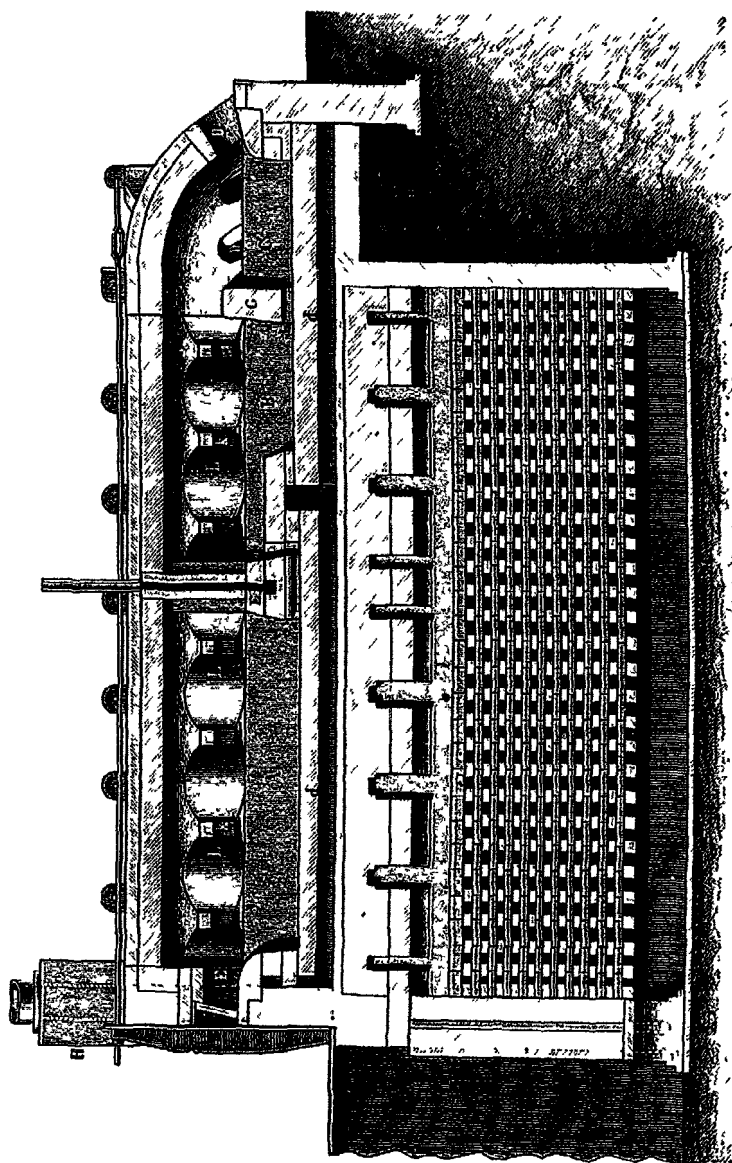

FIG. 127

fusibility of the mass. The materials, however, are not placed in the pots until these are heated up to a high temperature. The furnace is kept very hot until the first portion of the material added has been fused, and then a second portion is introduced. When all the solid matter is dissolved, the glass is still full of small bubbles of gas, and is of a spongy nature and not yet in a fit state for working. Moreover, the surface of the melted mass is covered by a layer of salts chiefly consisting of chlorides and sulphates of potassium and sodium which have escaped perfect vitrification; this is termed *glass-gall* or *sandiver*. Formerly, when impure materials were more generally employed than is now the case, large quantities of this scum were formed. Now, however, its formation is avoided by the use of purer materials and by the addition of charcoal if salt-cake is employed, care being taken not to add an excess, as otherwise the glass assumes a yellow colour. The last process in glass-making is termed the "fining," and consists in the removal by subsidence of the heavier non-vitrified particles and the escape of the bubbles of gas to the surface. For this purpose the glass must be brought into as liquid a state as possible, and consequently at this stage of the operation the temperature is raised to the highest point. When all the gas-bubbles have disappeared and the glass-gall has become clear and colourless, the temperature of the furnace is allowed to diminish slowly, the object being to reduce the fluidity of the glass to the point at which it becomes viscid and in a workable condition. Glass is worked either by the skill of the glass-blower, for the production of the ordinary hollow- or blown-glass articles, or by casting in presses, or, lastly, by pouring the "metal" out on to iron tables and rolling it into plates. The tools described by Blancourt in his work *On the Art of Glass*, printed in London in 1699, are almost the same as those now in use.

290 Annealing. All articles made of glass require to be very slowly and homogeneously cooled, for, glass being a bad conductor of heat, those portions of the glass which are on the outside solidify first, and contracting in this act of solidification leave the interior portions still warm, and these, unable to assume their natural position on cooling, are in a state of tension or condition of unstable equilibrium. Hence, glass which has been quickly cooled cracks and falls to pieces with the slightest disturbance, such as when even very slightly scratched, and is liable to break when exposed to sudden changes of temperature. All glass

therefore requires to go through the *annealing* process. This consists in submitting the glass articles to a very slow cooling. The construction of an annealing oven is shown in Fig. 128

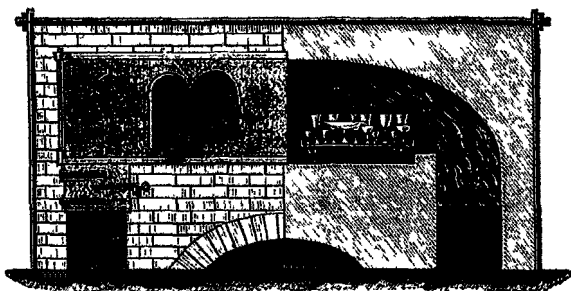

FIG. 128.

The fact of the brittleness of glass when suddenly cooled is well seen in the so-called *Rupert's Drops* (Fig 129), obtained



FIG. 129

by allowing a little melted glass to fall drop by drop into cold water. By merely breaking off the thin point the whole mass is converted with a slight detonation into a fine powder. Similarly an ordinary thick tumbler made of unannealed glass flies to pieces when the slightest scratch is made on the interior surface, as when a small piece of flint is allowed to fall into the glass.

291 Properties of Glass. Pure glass is perfectly transparent and colourless. It becomes soft at a red-heat, and hence it can be readily welded. At higher temperatures it becomes still softer and at last melts, forming first a thick and afterwards a mobile liquid, fusing the more readily, the smaller is its percentage of silica. According to its composition, glass varies considerably, both in specific gravity and lustre. Soda-lime glass has a specific gravity of from 2.4 to 2.6; the specific gravity of lead-glass rises as high as from 3.0 to 3.8, whilst the thallium-glass of Lamy reaches as high a point as 4.18. The

refractive index is also dependent upon the composition. The higher the atomic weight of the metals which it contains, the greater is the specific gravity of the glass, and the higher is the refractive index.

Kind of Glass.	Specific Gravity	Refractive Index for the D line.
Crown-glass	2.535	1.530
Fraunhofer's flint-glass	3.135	1.707
Guinand's " "	3.417	1.778
Lamy's thallium glass	4.180	1.673
Diamond	3.518	2.470

It is of especial importance for the chemist that his glass vessels should satisfactorily withstand the action of chemical reagents. Ordinary soda-lime or potash-lead glass is not only attacked by acids, but is easily decomposed when placed for some time in contact with boiling water, as was first observed by Bernard Palissy. It has already been stated (Vol. I. p. 25) that Lavoisier and Scheele were well aware of this solvent action of water upon glass, and that they explained this by the solution of the alkaline silicates, whilst the insoluble silica or lime-silicate floats about in the liquid. In his celebrated researches on the atomic-weights of the elements, Stas¹ describes a series of preliminary experiments made for the purpose of ascertaining the kind of glass which is least subject to such deterioration. He found that glass containing lead or alumina is readily acted upon by acids, whilst Bohemian potash-lime glass being rich in silica and free from alumina withstands this action best. Such glass is, however, difficult to work from its high melting-point, and in order to obtain a glass equally capable of resisting solvents and at the same time fusible enough to enable it to be worked into the various forms of chemical apparatus, Stas replaced half of the potash in the mixture used for the Bohemian glass by its equivalent of soda, so arranging the materials that the glass possessed the following composition:—

Silica	77.0
Potash	7.7
Soda	5.0
Lime	10.3
	100.0

¹ *Nouvelles Recherches, &c., Mem. Acad. Belg.* xxxv. 216.

Emmerling, who has lately investigated the same subject, obtained the following experimental results.¹ The solvent action of boiling solutions on glass vessels is within certain limits proportional to the time during which the action takes place. New glass vessels are attacked to a greater extent than old ones, but the action diminishes after a while. It is also proportional to the surface exposed to the action of the liquid, but it is independent of the amount of liquid which is vaporized in a given time. The action diminishes rapidly with increase of temperature. Even small quantities of the alkalis attack glass violently. Dilute acids, with the exception of sulphuric acid, exert even a less corrosive action than water itself. Those salts whose acids form insoluble calcium salts act in the same way as sulphuric acid does, and their action increases with the concentration of the solution. On the other hand, those salts whose acids form soluble calcium salts attack glass less powerfully, and their action diminishes with the concentration. Bohemian glass is attacked much less by acids than soda-glass, and it appears that all the constituents dissolve in the proportion in which they are present. From these observations it follows that in order to diminish the errors which occur in quantitative analysis from the solvent action of reagents upon glass, the contact of alkaline liquids must especially be avoided, any such liquid being acidified before evaporation. In the same way it is advisable to avoid the use of new glass vessels and also to diminish the time of evaporation and the volume of wash-water as much as possible, and for this latter purpose the use of the Bunsen filter-pump is strongly to be recommended.

292 *Devitrification of Glass. Reaumur's Porcelain.* In 1739, Reaumur observed that if a piece of glass be surrounded by sand or gypsum and heated strongly for a considerable length of time it is converted into a porcelain-like mass, to which he gave the name of *porcelaine par dévitrification*. It was at first believed that this change was brought about by the absorption of the materials in which it was imbedded, but Lewis, in the year 1763, concluded that the formation of Reaumur's porcelain depends upon the volatilization of the alkali contained in the glass.

This view was adopted by numerous chemists, amongst whom Dumas may be especially mentioned, under the assumption that a crystalline calcium silicate was formed which renders the glass

¹ *Ann. Chem. Pharm.* cl. 257.

opaque. According, however, to the experiments of Pélouze, Benrath,¹ and Stolba,² the porcelain-like glass possesses the same composition as ordinary transparent glass, and Benrath in his investigation on this substance, arrives at the following conclusions. Glass which contains more silica than the amount corresponding to the formula $M_2Si_2O_7$, readily becomes devitrified. Devitrified, as well as ordinary transparent glass, consists of mixtures of an amorphous and of a crystalline mass, or of mixtures of crystals which have separated out in an amorphous solidified mother-liquor. The existence of crystallized structure in ordinary glass is shown by the fact that if the surface of all melted unpolished glass be treated with strong aqueous hydrofluoric acid, and the etched portions well-washed with sulphuric and hydrochloric acids, the etched surface exhibits, under the microscope, a distinct finely-grained crystalline structure (Leydolt). In apparently amorphous glass then, it would appear that we have to do with a supersaturated solution which has been quickly solidified, whilst in the case of Reaumur's porcelain sufficient time has been given for the formation of larger and visible crystals. Other views are however maintained by certain chemists on this question. Thus Péligot³ maintains that the vitreous mother-liquor contains more alkaline silicate than the crystalline portion, inasmuch as devitrified glass placed in a moist atmosphere exudes carbonate of potash in a soluble form. The same chemist also states that the melting-point of devitrified glass is higher than that of the vitrified portion.

Badly prepared window-glass, especially that rich in alkalis, becomes opaque on exposure to the air. This is due to a devitrification of the surface brought about by the action of water, carbon dioxide, and ammonia, and depends on the fact that the alkalis are separated and washed away by water, whilst an iridescent coating, consisting of a thin film of calcium silicate, remains on the surface. This iridescence of glass is especially well seen in antique glass which has been buried in the earth for a considerable length of time. A similar iridescent surface on glass is now produced artificially by heating ordinary glass under pressure in contact with hydrochloric acid.

¹ *Die Glasfabrication*, 1875, p. 18.

² *Journ. Pract. Chem.* xc. 465 ; xciii. 118.

³ *Le Verre*, Paris, 1877, p. 45.

OPAQUE AND COLOURED GLASS.

293 Transparency is certainly the most important property of glass, and yet for some purposes translucent or even opaque glass is useful. The ordinary opalescent or enamelled glass is either soda-glass or flint-glass which has been rendered opaque by the addition of an insoluble powder such as bone-phosphate or mineral-phosphate. Cryolite has also been employed in place of phosphate, giving rise to a material manufactured in Pittsburg, U.S.A., and known under the name of hot-cast porcelain. Ellis describes the manufacture of milk-glass of this kind as consisting in fusing together 1 part of cryolite with from 2 to 4 parts of white sand, whilst, according to Williams, an addition to this mixture of 9 per cent. of zinc oxide improves the result. Instead of cryolite, fluor-spar or sodium aluminate may be employed.

Another opaque variety of glass is known under the name of *enamel*. This name originally signified lead-glass rendered white by oxide of tin. At the present day several oxides are employed for this manufacture, such as those of antimony and arsenic, as well as permanent white or sulphate of barium. Enamel is used especially for covering the surface or for "enamelling" iron vessels used for cooking and other purposes.

The ancients were well acquainted with the mode of preparing *coloured glass*, and not only did they colour it in mass, but they were conversant with the process of "flashing," that is of coating a white glass with coloured glass. An example of this is seen in the celebrated Portland vase. The white figures of Peleus and Thetis have been obtained by cutting away the white surface which originally covered the whole vessel. Figures on flashed glass are still prepared in the same way by cutting away the outer coating, and thus allowing the colour of the lower layer to be seen. The process of flashing is also employed when the colouring matter would be too intense if the whole mass were coloured, and thus by varying the thickness of the outward crust of coloured glass differences in tint can be brought about. Blown-glass can be coloured either on the exterior or interior surface. In the first case the glass-blower brings the requisite quantity of colourless glass on to his

blowpipe, and dips this into the molten coloured glass so as to cover it with a thin film; whilst in the other case the coloured is covered with the colourless glass.

294 *Ruby Glass.* The older chemists were acquainted with the fact that glass can be coloured a ruby-red tint by means of gold compounds. Thus Neri describes a method of preparing ruby glass by adding to the glass-maker's materials the residue from the evaporation of a solution of gold in aqua-regia. General attention, however, was drawn to this subject in the 17th century, after the discovery of the *purple of Cassius*, obtained as a dark-red powder by mixing the chlorides of gold and tin. Amongst other chemists, Kunkel occupied himself with the preparation of this gold pigment, and obtained from the Elector Frederic William the sum of 1,600 ducats for his experiments.

In his *Ars Vitriaria Experimentalis* he says: "There was a certain *Doctor medicinae*, by name Cassius, who discovered the *præcipitatio Solis cum Jove*: to this perhaps Glauber may have given occasion, but I leave this undecided. The aforesaid Doctor Cassius endeavoured to bring it into glass, but when he tried to form a glass with it, or when he took it out of the fire, it was as colourless as crystal, and he could not bring any permanent red out of it. He may, however, have observed, being a man curious about these things, amongst the glass-blowers that when they softened glass in the flame of the lamp the colour underwent a change. Thus he came to try the same plan with gold glass, and obtained a splendid ruby colour. When I learnt this, I set to work at once, and I know best what trouble I had to hit the proper composition, and to find out how to get it always red."

The secret which is involved in the above words is explained in the *Laboratorium Chymicum*, which appeared after his death: "This ruby glass possesses the property that when the glass is melted with the ☉ (gold) it comes out of the fire as clear as crystal, and in order to become red must be heated again in a mild fire."

Ruby glass, now prepared by the addition of the purple of Cassius or of gold chloride, possesses the property above described, and remains perfectly colourless when quickly cooled; but when heated to the point at which it becomes soft, the whole mass attains a ruby-red colour. By the addition of tin or silver compounds, a variety of tints between a rose-red colour

and a red-purple colour can be obtained. The exact nature of the gold compound which produces the ruby colour in glass is not yet known, nor can we explain why the glass becomes red only on a second heating. Some suppose that the colour is due to metallic gold in so finely-divided a state that the substance only allows red light to pass through it. The amount of gold contained in ruby glass is very small, amounting to from 0.05 to 0.06 per cent.

295 *Copper Ruby Glass.* Cuprous oxide also colours glass a fine and intense red, but inasmuch as this compound readily undergoes oxidation and as cupric oxide imparts to glass a light green colour, a reducing agent such as iron-scale is added to the materials. Oxidation is also prevented by poling the molten mass with pieces of fresh wood. The mass on cooling appears of a light green colour, but becomes red on re-heating. The preparation of this glass was also understood in early times. Klaproth found both copper and iron in a sample of old Roman glass, and in the beginning of the 17th century Neri described a method of calcining copper in order to colour glass, and stated that iron-filings, iron-scale, or other reducing agents must be added in order that the colour may come out a bright red. Kunkel also employed himself with the preparation of this glass, but in later times the art of producing red glass without purple of Cassius was lost, and it was not until the year 1828 that Engelhardt examined the question and obtained a prize which the Berlin Polytechnic Society had offered for the discovery, since which time the method has been generally practised. Cuprous oxide possesses a very strong colouring power, and for this reason copper-ruby is generally used for flashing or casing. Ferric oxide (colcothar) also imparts a red colour to glass, but one less brilliant than the two preceding ones.

Yellow Glass is prepared by the addition of potassium antimoniate or of antimony-glass, a fused and imperfectly oxidized sulphide of antimony, which imparts to glass a topaz-like tint. Other yellow colours are obtained by the use of silver chloride and silver borate. Organic bodies also impart a yellow tint to glass. This must have been observed by Thomas Aquinas, who describes a mode of preparation of artificial topaz by placing a piece of aloe-wood over the vessel in which the glass is melted. It was formerly believed that this brown colour was due to carbon. Splitgerbe has, however, lately shown that it is caused by the presence of the sulphides of the alkali metals obtained

by reduction from the sulphates contained in the material used for glass-making.

296 Green Glass is obtained by the addition of cupric oxide, and this fact was known to the ancients, the above substance being found in antique glass. According to Seneca, Democritus of Abdera was acquainted with a method for producing the emerald artificially, and Theophrastus, about 300 B.C., described a mode of colouring glass green by means of copper. Other green tints are obtained by the addition of oxide of chromium and ferrous oxide. The latter, however, gives a dull bottle-green colour.

Cobalt oxide colours glass a fine *blue*, and this oxide has been used from early times for this purpose. Davy found cobalt in all the antique blue glass which he examined.

The *violet* colour of glass is due to manganese oxide. This is obtained by the addition of black oxide of manganese and nitre.

A fine *black* opaque glass is obtained by the addition of sesquioxide of iridium to colourless glass, and a common black glass is prepared by adding large quantities of ferric oxide, with which copper oxide or cobalt oxide is frequently mixed.

Strass and Paste. The property of glass to attain a variety of tints by the addition of various metallic oxides is made use of for the production of artificial gems or paste, and this art has now attained such perfection that it is difficult even for an adept to ascertain upon mere inspection whether a gem is real or artificial. The discrimination can, however, be made at once by determining the hardness of the stone with a good file, inasmuch as the artificial are much softer than the natural gems. Strass is employed for the basis of paste, and is distinguished by its high refractive power and bright lustre. According to Donault-Wieland *topaz* is formed by adding to 1000 parts of strass, 40 parts of antimony-glass, and 1 part of purple of Cassius. *Ruby* is obtained from the ingredients of the topaz mixture by fusing 1 part of this with 8 parts of strass and allowing the fused mass to remain at the temperature of the furnace for thirty hours. *Emerald* is prepared by fusing 1000 parts of strass, 8 parts of cupric oxide, and 0.25 part of chromium oxide. *Sapphire* can be made by the addition of 15 parts of cobalt oxide to 1000 of strass; *amethyst* requires the addition of 8 parts of manganese dioxide, 5 of cobalt oxide, and 2 of purple of Cassius; whereas the *beryl* or *aqua-marina* is pre-

pared by adding 7 of antimony-glass and 0.4 of cobalt oxide to the 1000 of strass, and *Syrian garnet* or *carbuncle* requires 500 of antimony-glass and 4 parts each of manganese dioxide and purple of Cassius to the same quantity of strass. These special tints can, however, be readily varied at pleasure.

297 *Avanturine Glass or Artificial Avanturine.* This material is a reddish or greenish glass filled with minute crystals or spangles, which have a golden lustre. It has received its name from a rare form of quartz which occurs in Spain and the Altai, containing spangles of mica or other mineral. Artificial avanturine is more beautiful than the natural mineral, and the method of its manufacture is said to have been discovered by chance in the 13th century by Briani in Venice. The artificial avanturine was largely employed for the preparation of ornaments and especially for Venetian Mosaic work. The details of its preparation were long kept secret, and the process was only carried out by a few of the highest Venetian families. In the year 1847 Pettenkofer¹ investigated the preparation of the antique hæmatine, an opaque red glass, and in the preparation of this material he obtained by accident artificial avanturine. Many not wholly successful attempts have been made to determine the exact conditions under which the avanturine is thus formed, and the Venetian manufacture still maintains its supremacy. Avanturine is a white soda-lime glass, containing an excess of alkali, and coloured red by cuprous oxide, containing an enormous number of minute spangles of metallic copper. According to Hautefenille, a green cupric glass is first prepared; to this iron-filings are gradually added until it becomes red and opaque; hæmatine glass is thus formed, which is then well covered with ashes, and allowed gradually to cool, when the artificial avanturine glass is formed.

White and coloured *enamels*, largely used for the preparation of thermometer scales, as well as Mosaic work, usually consists of common flint-glass, which is intensely coloured with the above-mentioned oxides and then poured on to the metal, to the surface of which it adheres.

298 *Toughened Glass.* The fact that glass can be toughened was discovered by De la Bastie. It is obtained by dipping glass heated almost to redness into oil, also heated to 300°, and allowing it then to cool gradually. Sheets of glass are also toughened by allowing them to cool between plates of heated

¹ *Diag. Polyt. Journ.* cxlv. 122.

metal. The glass thus prepared is much less brittle, and better able to withstand sudden changes of temperature than ordinary glass. Table-glass thus toughened is not readily broken when thrown on to the ground. If, however, it be thrown from a great height or with great force, it breaks into fine splinters. Although a crack may occur in a vessel of toughened glass without the whole of the mass breaking up, yet it cannot be cut with a diamond; from this it would appear that the molecules of toughened glass are in a molecular condition somewhat similar to those of the Rupert's drops.

299 Etching of Glass. The etching of glass with hydrofluoric acid was known in the 17th century, but it is only recently that this process has been employed for the decoration of glass, and now etched glass is much used in place of the more expensive cut-glass. Gaseous hydrofluoric acid as well as many soluble fluorides produce an opaque surface on glass, but the surface of glass etched with liquid hydrofluoric acid presents, according to the concentration of the acid, a more or less transparent character. According to Tessié de Mothay and Maréchal, the best mode of obtaining opaque- or ground-glass by means of hydrofluoric acid is to employ a bath made of 1000 parts of water, 250 parts of crystallized double fluoride of hydrogen and potassium, 250 parts of commercial hydrochloric acid, and 140 parts of potassium sulphate. This last salt renders the fluorides of calcium and lead which may be formed less soluble, whereby they are separated out in the crystalline form on the portions of the glass which have been etched and thus tend to render the surface more opaque.

POTTERY, PORCELAIN, AND EARTHENWARE.

300 The potter's art is one of the oldest in existence. The Egyptians were well acquainted with the means of glazing ware made of burnt clay, as well as with the art of enamelling in colours. Amongst European nations the Etruscans were especially celebrated in early times for their proficiency in the manufacture of painted pottery-ware, and in Pliny's time several towns in Greece and Italy were well known for the beauty and artistic taste of their vases, urns, and other pottery wares.

Porcelain was not known to the Romans, although the Chinese have manufactured it for ages, and the Egyptian tombs contain remains of vessels made of a material closely allied to porcelain. The art of glazing pottery with the oxides of lead and tin was generally practised in Europe during the Middle Ages, and we find a description of the process then adopted in the writings of the alchemists Peter Bonus and Albertus Magnus, at the beginning of the thirteenth century. In the following century the potter's art made great strides. Agricola published many receipts concerning this manufacture; amongst others, he states that not only a mixture of litharge with tin oxide gives a good glaze, but that the former oxide may be employed alone for this purpose.

Amongst those who have been most active in promoting the progress of the ceramic art the name of Bernard Palissy stands pre-eminent. Devoting himself with self-sacrificing assiduity to the production of glazed and coloured faience, Palissy laid the foundation of modern art pottery. His numerous writings, published during the latter half of the sixteenth century, spread a knowledge of his experimental methods throughout Europe; but his works *L'art de terre et des terres d'argile* are confined to a description of the manufacture of earthenware; it was not until the year 1709 that the method of making porcelain was discovered by Bötticher, and in the following year the celebrated porcelain manufactory at Meissen, in Saxony, was established.

The mode of preparation of the Meissen porcelain was naturally kept secret, and the King of Prussia instructed the celebrated chemist Pott to determine the nature of the materials used, and he being unable to obtain any satisfactory information respecting the materials there employed, was obliged to investigate the properties of those substances which might possibly be used in the manufacture, mixed in varied proportions, and for this purpose Pott is said to have made no less than 30,000 experiments. To these we are mainly indebted for the establishment of the reactions which occur when various minerals are heated, and much valuable information applicable to the manufacture of porcelain was thus obtained. About the same time Reaumur endeavoured to determine the secret of porcelain-making, and found that it is produced by the union of two earths, one of which is fusible, whilst the other fuses only at a very high temperature, so that by the firing of both together a translucent mass is formed.

His investigations were taken up in the year 1758, by Lauragnais, D'Arcet, and Legay, in France, and by the help of Macquer they succeeded in re-discovering the lost art of porcelain-making, and in the year 1769 the celebrated porcelain manufactory of Sèvres was founded.

Even up to the beginning of this century real porcelain was a material of great rarity and value. At the present day, however, it is cheap, and employed for making the most ordinary articles of every-day use.

301 *Hard porcelain or True porcelain* is distinguished by its fine and hard translucent structure, and is with difficulty attacked by chemical reagents. According to Emmerling's experiments water and acids, even when boiled, have next to no action on porcelain, and it is attacked by alkalis less powerfully than glass, and hence in chemical and analytical operations the use of porcelain is much to be preferred to that of glass. Porcelain also stands rapid alteration of temperature without cracking, and this property is one of extreme value to chemists, whilst its beauty, and the fact that its surface is capable of taking colours which will stand firing, render it of great importance in the manufacture of objects of art. The principal material of which porcelain is composed is *kaolin* or *China-clay*, an infusible plastic substance derived from the decomposition of felspar or feldspathic rocks. Pure felspar has the composition $(KNa)_2Al_2Si_6O_{16}$, whilst pure kaolin is represented by the formula $H_2Al_2Si_2O_8 + H_2O$. This substance is a distinct mineral species, and frequently occurs crystallized in four- or six-sided tablets belonging to the rhombic system. More commonly, however, it is found as a white or yellowish-white amorphous mass, and contains a small quantity of ferric oxide, or magnesia. Kaolin is found in China, near the Kauling Mountains, whence its name is derived, and in other places. In Europe the finest China-clay is found in Limoges, and it is from this that the celebrated Sèvres porcelain is made. Good China-clay is likewise found in Cornwall, Saxony, various localities in America, &c. Ordinary clay consists of a mixture of kaolin with calcium carbonate, magnesium carbonate, ferric oxide, silica, and organic matter. The following table gives the composition of some of the clays:—

	Silica.	Alu- mina.	Ferrie Oxide.	Lime.	Mag- nesia.	Alkala.	Water.
Kaolin from China ...	50·63	32·74	2·64	0·50	0·27	2·52	10·01
„ „ Yrieux ...	48·37	34·95	1·26	—	—	2·40	12·62
„ „ Aue	46·00	39·00	0·25	—	—	—	12·74
„ „ Cornwall ..	46·38	33·60	—	3·47	—	1·77	9·08
Cornwall clay ...	45·82	39·42	—	—	—	—	14·26
Strassburg „ ...	66·70	18·20	1·60	—	0·60	—	12·00
Stourbridge „ ...	63·30	23·30	1·80	0·73	—	—	10·30
Dorsetshire blue clay ..	46·38	38·04	1·04	1·20	—	—	13·44

302 When strongly heated, felspar fuses to a colourless glass, owing to its containing alkaline silicates. Clay, however, only bakes together under the influence of heat, forming a hard but porous solid. It is to this property, and also to that of its forming with water a plastic mass, that clay owes its employment in pottery. In the manufacture of porcelain the infusible kaolin is mixed with a frit, flux, or fusible material, consisting of a fusible silicate. This on fusion penetrates into the pores of the heated clay, producing a hard, homogeneous, translucent, lustrous mass. The name porcelain is derived from a Portuguese word *porcellana*, a shell which is similar in general appearance to porcelain. The ordinary flux employed is felspar, but sometimes quartz, chalk, or gypsum is added. The relative amounts of these materials which are used depend upon the nature and composition of the kaolin employed, and this varies according to the locality in which it is found. The following table gives mixtures employed in a few of the more important manufactories :—¹

Sèvres.—The materials employed in the manufacture of this celebrated porcelain are always mixed in proportions which give a mass having the following percentage composition :—

Silica.	Alumina.	Lime.	Potash.
58·0	34·5	4·5	3·0

The ingredients which are employed in different years for the

¹ Knapp, *Chemical Technology*.

production of this mass are, however, very different, as is seen in the following table:—

	1836.	1837.	1843.
Kaolin	7·0	64·0	48·0
Argillaceous kaolin . . .	9·2	18·0	48·0
Quartz "	12·0	15·0	—
Quartz sand from Aumont	5·3	0·1	—
Washed chalk	3·5	2·9	4·0
	100·0	100·0	100·0

Vienna.—The ingredients used for the preparation of the well-known Viennese porcelain were in 1815 as follows:—

Passau kaolin, No. 1	101
" " No. 2	111
Kaolin from Zettlitz	98
Quartz	18
Felspar	57
Lime	15
	400·0

Nymphenburg.—This porcelain is made without felspar, and is a lime porcelain made of the following ingredients:—

Passau Kaolin.	Bodenmais Quartz.	Marble.
100	40	10 = 150.

When a mixture has proved to be successful each manufacturer adheres strictly to his special receipt, not only because an alteration in the proportions would render a different temperature necessary for burning, but especially because this would also entail a greater or less shrinking of the mass, for all clays, when burnt in the kiln, undergo a certain amount of shrinking, and this varies according to their composition. It is, however, extremely difficult so to arrange the materials that the shrinking shall take place to the same extent in different mixtures; and as the manufacturer has frequently to prepare his wares to pattern, it is necessary to keep to one mixture. In the use of felspar, quartz, or chalk the most important point to be ascertained is their purity, whilst in the case of clay the

determination of its fire-resisting power has also to be made. On this subject Bischof and Richters' have published elaborate investigations, to which we must refer the reader.

The greatest care has to be taken in the thorough mixing of the materials, and in obtaining them in a very finely-divided state. For this purpose the clay is ground and levigated with water, and the water got rid of by careful pressing through bags. In this way the mass of porcelain clay is brought to the right state of consistency. It is then well mixed by kneading, and is allowed to remain for a considerable length of time in a moist place, when the organic matter contained in the clay undergoes putrefactive decomposition: this seems to increase the plasticity of the mass; but the exact action which takes place under these circumstances is not well understood. The material is then either worked up on the potter's wheel, or brought into the requisite shape by pressing into moulds, and the objects thus prepared are allowed to dry at the ordinary temperature before firing. True porcelain is glazed with a felspathic glaze, which must be colourless, smooth, and have a glassy lustre. The composition of porcelain glaze is seen in the following table:—

Sèvres.	Meissen.	Berlin.
Pure ground felspar.	Quartz 37	Quartz 43
	Kaolin from Seilitz 37	Kaolin from Morl 31
	Lime 17.5	Gypsum 14
	Broken porcelain 8.5	Broken porcelain 12
	100.0	100

Before glazing, the porcelain requires to undergo a preliminary process of baking, it being placed, for this purpose, in the upper portion of the porcelain kiln. The fired goods are then dipped into water containing the finely-divided glaze in suspension. They are then dried and again exposed to a higher temperature in the porcelain kiln, which consists essentially of a high reverberatory furnace. The flame and hot gases surround the earthenware "seggars," or infusible crucibles, in which the porcelain ware is placed to protect it from the smoke and direct action of the flame. When the temperature has reached its maximum, the kiln with its contents is bricked up, and the whole allowed to cool very slowly. This annealing process is necessary, as the glaze forms a true glass, and if the heated mass were quickly

¹ C. Bischof, *Disgl. Polyt. Journ.* vol. clix.—ccxi. † Richters, *ibid.* vol. cxcii.—cxvii.

cooled the porcelain would be brittle from the unequal tension of its different parts.

303 *Painting on Porcelain* is a branch of the art of glass-staining, the only difference being that in the last case the colouring matter is viewed by transparent light, whereas in the former case the colours are seen by reflected light. The same substances are employed for painting upon porcelain as are used in colouring glass. They are divided into two classes: (1) Those which are not destroyed at the temperature of the porcelain kiln, and can be painted on the ware below the glaze,—these are termed refractory colours, and include cobalt-blue, chrome-green, the brown produced by oxide of iron or manganese, chromate of iron, &c., and uranium black; and (2) those colours which are injured when heated above a certain temperature,—these are termed muffle-colours, because they are fixed on the ware by a separate firing at a lower temperature in a muffle and not in the kiln. Muffle-colours are put on over the glaze. The following substances are used as muffle-colours: oxides or salts, such as iridium oxide, cupric oxide, cuprous oxide, chromate of lead, silver chloride, purple of Cassius, &c., and as flux for these are employed, quartz or sand, borax or boric acid, felspar, litharge and red-lead, nitre and the carbonates of potash and soda.

304 *Tender or Fritted Porcelain*. This form of porcelain was first prepared in 1695, by Morin in St. Cloud. The mass resembles that of true china, but the glaze is much more fusible than the felspathic glaze used for the latter material and it is, therefore, less able to resist the high temperature of the porcelain kiln than true china. This is the kind of porcelain specially manufactured in England. The materials employed in this manufacture are: (1.) The mass or body composed of Cornish stone, China-clay, or decomposed pegmatite. (2.) The frit or fusible material used to bind together the China-clay. This consists of bone-ash or mineral phosphate with, sometimes, the addition of borax. (3.) The glaze is much more fusible than the mass and consists of bone-ash, sand, borax, potashes, and lead oxide. The difference in fusibility between the mass and the glaze constitutes the main difference between fritted porcelain and true porcelain. The following are mixtures in use for English china:—

	I.	II.	III.	IV.
Bone-ash . . .	47	41	36	47.3
Cornish stone . .	31	30	21	—
China-clay . . .	22	29	21	33.8
Blue Dorset clay	—	—	12	—
Felspar	—	—	—	18.9
	100	100	100	100.0

The glaze used for English table-ware consists of:—

Cornish stone . . .	34
Chalk	17
Ground flint . . .	15
Borax	34
	100

These materials are fritted, then ground and mixed with 10 per cent. of Cornish stone and 20 per cent. of white-lead.

Parian or Carrara biscuit-ware is a white unglazed porcelain, less fusible than ordinary tender porcelain and largely used for the preparation of statuettes.

Stoneware is distinguished as fine and ordinary stoneware, and is related to porcelain, inasmuch as it is also prepared from clay fritted together with a flux, and therefore consists of a homogeneous dense mass which is distinguished from porcelain by its opacity, due to the fact, that the frit or fusible porcelain is not dissolved throughout the mass as is the case with porcelain. The materials used are the plastic clays and pipe-clays, found in large quantity in the coal measures, and these are mixed with a felspathic glaze. The glaze employed sometimes contains lead and borax. The frit is always contained in larger proportion in stoneware than in porcelain, and hence it does not require to be exposed to so high a temperature in the process of baking. Stoneware is therefore a cheap and effective substitute for porcelain, as it is produced at a lower cost and at the same time can be more easily worked.

305 *Earthenware or Faience.* This material differs from the foregoing, inasmuch as the mass before glazing is porous and earthy. Earthenware is made from a coloured plastic clay which, on burning, forms a hard porous mass, and in order to diminish the shrinking it is frequently mixed with marl. It

is glazed by throwing common salt into the kiln when the burning is nearly complete. This is volatilized and decomposed by the aqueous vapour and the products of combustion, with formation of hydrochloric acid and soda, which latter unites with the clay to form a sodium aluminium silicate. Salt-glaze ware is largely used for drain-pipes, pipes for conveying acid gases and liquids, and for vessels for storing acids, as well as for ordinary domestic use.

Faience was known and manufactured in the 9th century by the Arabians, and the knowledge of the manufacture passed with the Moors into Spain, and established itself in the island of Majorca, whence the name *Majolica* is derived, being the old Tuscan name for this island. The same industry in Italy was named faience from the name of the town of Faenze in the States of the Church, where it was established in the 13th century, and flourished until the 15th. In France, the manufacture was commenced by Bernard Palissy, in the 16th century.

Fine Faience or Semi-porcelain. This is prepared from a white plastic clay to which ground quartz, or flint, or even felspathic stone, is added in the requisite quantity. After the first burning it is porous and adheres to the tongue, and is then glazed with an opaque glaze consisting of borax, quartz, soda, and oxide of lead. Semi-porcelain is made from an impure clay, and the peculiar colour which it possesses is covered by this white opaque enamel.

306 *Common Pottery Ware* is made of the most impure forms of clay, coloured brown-yellow or red with ferric oxide and other oxides. In many cases it also receives an easily fusible lead glaze obtained by mixing lead oxide, or even ground galena, with the clay.

The various kinds of melting crucibles which are made of clay have a special interest to the chemist. These require to be made of material which will stand a very high temperature without softening or breaking up, and capable of withstanding rapid changes of temperature. The well-known Hessian crucibles are made of a clay containing about 71 parts of silica, 25 of alumina, and 4 of oxide of iron, and this is mixed with one-third to one-half its weight of quartz sand.

INDIUM. In. = 1134.

307 This metal was discovered in Freiberg zinc-blende in the summer of the year 1863, by Reich and Richter, by means of spectrum analysis.¹ Indium also occurs in other zinc-blendes, although present only in very small quantity. In order to prepare indium it is best to employ metallic zinc, such as that from Freiberg, which, however, does not contain more than 0.1 per cent. The metal is treated with such a quantity of hydrochloric acid that a small portion remains undissolved, and when the solution is allowed to stand for two or three days the whole of the indium is found to be precipitated on the residual zinc. The metallic powder is then washed off from the zinc, a few drops of dilute sulphuric acid added in order to dissolve any basic zinc chloride which may be formed, and the spongy metal well washed with hot water, then treated with nitric acid, and the acid solution, without filtration, boiled down with an excess of sulphuric acid until all the nitric acid is driven off. The solution is then filtered, the residue well washed, and a large excess of ammonia added to the filtrate. The zinc, cadmium, and copper then remain in solution whilst the whole of the indium together with iron, lead, and a small quantity of zinc, cadmium, and copper remain behind. After well washing, the residue is dissolved in a small quantity of hydrochloric acid, an excess of hydrogen sodium sulphite added, and the solution boiled until it does not any longer smell of sulphur dioxide. A precipitate is thus obtained of indium sulphite, which for further purification may be dissolved in sulphurous acid; on boiling this solution the pure salt separates out,² and this when strongly heated decomposes, leaving a residue of indium oxide. The oxide can then be reduced to metal by ignition in a current of hydrogen or by fusion with sodium. The latter method appears to be the best suited for the preparation of large quantities. For this purpose the finely-divided oxide is placed in layers in a crucible with thin slices of sodium, the mixture pressed down and then covered with a thick layer of anhydrous sodium chloride. The porcelain crucible is next placed in a Hessian crucible provided with a cover and

¹ *Journ. Praet. Chem.* lxxxix. 444; xc. 172; xcii. 480.

² *Bayer, Ann. Chem. Pharm.* clviii. 372.

heated first gently and, as soon as the reaction is over, to a moderate red-heat. The brittle alloy which is then obtained is boiled several times with water, washed with alcohol and ether, and again fused under a layer of potassium cyanide. The regulus is still not quite free from sodium, and in order to remove these traces it is thrown, in small pieces, into fused carbonate of soda, and thus the metal is obtained in the pure state.¹

Indium is a white non-crystalline metal, easily malleable and softer than lead. Its specific gravity is 7.42, and its melting point 176°. It retains its metallic lustre in the air, and even in boiling water. Heated on charcoal before the blow-pipe it colours the flame blue, and gives an incrustation of the oxide. It dissolves slowly in hydrochloric and dilute sulphuric acids, but readily in nitric acid.

Indium Oxide, In_2O_3 , is a pale yellow powder, which on heating becomes brown, but regains its original colour on cooling. After ignition it dissolves only slowly in cold dilute acids, but quickly when the acid is warmed.

Indium Hydroxide, $\text{In}_2(\text{OH})_6$, is formed when ammonia is added to a soluble indium salt. The hydroxide is thrown down as a gelatinous precipitate, which on boiling becomes heavy and dense, and when heated it is easily converted into the oxide. When the oxide is heated in a current of hydrogen, a black pyrophoric powder is obtained, which appears to contain the lower oxide, InO .

SALTS OF INDIUM.

308 *Indium Chloride*, In_2Cl_6 . The metal burns at a dark red-heat in a current of chlorine, evolving a greenish-yellow light with formation of the chloride. The same compound is easily formed when the oxide, mixed with charcoal, is heated in chlorine, when it sublimes in the form of soft colourless plates. It is extremely deliquescent, and dissolves in water with a hissing noise and evolution of heat. On evaporating the solution an insoluble basic salt is obtained.

Indium also combines with bromine and iodine when heated in the vapours of these elements. The bromide closely resembles

¹ Winkler, *Journ. Pract. Chem.* cii. 273.

the chloride, and the iodide is a yellow crystalline mass, which on heating melts to form a reddish-brown liquid.

Indium Sulphite, $\text{In}_2(\text{SO}_3)_3 + 4\text{H}_2\text{O}$. This is a crystalline powder, the preparation of which has been already described. It dissolves easily in aqueous sulphurous acid, and separates out on evaporation in distinct crystals.

Indium Sulphate, $\text{In}_2(\text{SO}_4)_3$, is obtained by the careful evaporation of a solution of the oxide in an excess of sulphuric acid, in the form of a white powder very soluble in water. On strongly heating it is converted into an insoluble basic salt. On evaporating the acid solution under the desiccator, deliquescent crystals of the acid salt having the composition $\text{H}_2\text{In}_2(\text{SO}_4)_4 + 8\text{H}_2\text{O}$ are deposited.

Indium-Ammonium Alum, $\text{In}_2(\text{SO}_4)_3 + (\text{NH}_4)_2\text{SO}_4 + 24\text{H}_2\text{O}$, is deposited in well-defined regular octohedrons, which dissolve at 16° in half their weight, and at 40° in about a quarter of their weight of water and melt at 36° .¹ If a solution be allowed to crystallize at this temperature crystals of the hydrate $\text{In}_2(\text{SO}_4)_3 + (\text{NH}_4)_2\text{SO}_4 + 8\text{H}_2\text{O}$, separate out.

Potassium and sodium form analogous hydrates. The corresponding alums (containing 24 molecules of water) have not been obtained with indium and the fixed alkalis.

Indium Nitrate, $\text{In}_2(\text{NO}_3)_6 + 3\text{H}_2\text{O}$, forms deliquescent needles soluble in both water and absolute alcohol. These on heating are easily converted into a basic salt.

Indium Sulphide, In_2S_3 . Indium and sulphur combine together at a temperature near redness, with evolution of heat, to form a brown infusible mass. Sulphuretted hydrogen passed into a solution of an indium salt which is not too acid or too concentrated, precipitates yellow indium sulphide, which on heating with sulphide of ammonium is converted into the white hydro-sulphide.

DETECTION AND ESTIMATION OF INDIUM.

309 The indium compounds are distinguished inasmuch as when moistened with hydrochloric acid they tinge the non-luminous gas-flame a dark-blue colour. The spectrum consists of an intense indigo-blue line, $\text{In}\alpha$ w.l. 4509, and a less intense violet line, $\text{In}\beta$ w.l. 4101. It is from the above reaction that the metal derives its name.

¹ Rossler, *Journ. Pract. Chem.* [2], vii. 14.

Zinc precipitates metallic indium from solutions of its salts. Caustic soda and potash precipitate the hydroxide, which partly dissolves in an excess, but is completely deposited again on boiling; it is insoluble in ammonia. This reaction is employed for the separation of indium from the other metals, as is also the formation of the insoluble hydrogen sulphite, as has already been described, and the fact that sulphide of indium is insoluble in dilute acids.

The atomic weight of indium has been determined by Reich and Richter, as well as by Winkler¹ and Bunsen,² by converting the metal into the oxide. By dissolving in nitric acid and heating the nitrate, Winkler obtained the number 113·3, whilst Bunsen obtained the number 113·47.

GALLIUM. Ga. = 69·8.

310 This metal was discovered in 1875 by M. Lecoq de Boisbaudran³ by means of spectrum analysis. He found the new element in the zinc-blende of Pierrefitte in the Pyrenees and patriotically gave to it the name which it now bears. It is also found in the blende from other localities. Thus a yellow transparent blende from Asturia and a black blende from Bensberg contain it; and that from Bensberg, although the richest, contains only 16 mgr. of gallium per kilo. All other zinc ores which have been tested for gallium have either yielded negative results, or have contained mere traces of the new metal.

In order to prepare gallium, the ore according to its physical character is dissolved either in aqua-regia, hydrochloric acid, or sulphuric acid, and the solution decomposed by means of metallic zinc. The precipitate thus thrown down, which contains most of the foreign metals present in the blende, is then treated with hydrochloric acid, and the liquid again precipitated with zinc in the cold. As soon as the evolution of hydrogen becomes feeble, the solution is poured off from the precipitate and saturated with sulphuretted hydrogen, the precipitate filtered off, the excess of sulphuretted hydrogen driven off, and the liquid fractionally precipitated with sodium carbonate in the

¹ *Jahresb.* 1867, p. 260.

² *Pogg. Ann.* cxlf. 1.

³ *Compt. Rend.* lxxi. 493 and 1100.

cold until the precipitate thrown down no longer exhibits the gallium line when examined with the spectroscope. It is then dissolved in sulphuric acid, gently evaporated until the excess of sulphuric acid is almost completely removed, the residue treated for some time with cold water, and the solution diluted with water, then heated to boiling, when basic gallium sulphate separates out, which must be filtered off whilst hot. This precipitate is dissolved in a small quantity of sulphuric acid; to this liquid a slightly acid solution of ammonium acetate is added, sulphuretted hydrogen passed through to saturation, the solution filtered, and the filtrate, diluted with water, heated to boiling, the precipitate which forms being washed with boiling water. This is then dissolved in a small quantity of sulphuric acid, a slight excess of alkali added, and the alkaline solution submitted to electrolysis. Metallic gallium is thus deposited on the platinum pole, and in order to obtain it in the perfectly pure state it is treated with warm dilute nitric acid free from chlorine. Sixty-two grms. of gallium were exhibited in the Paris Exposition of 1878, having been prepared from 2,400 kilos. of blende by Lecoq de Boisbaudran and Jungfleisch.¹

Metallic gallium possesses a bluish-white colour, and has the remarkable property of fusing at 30° . The molten metal possesses the colour of silver, and remains liquid for many weeks at the ordinary temperature, and even when exposed to 0° . If, however, the globule be touched with a small fragment of solid gallium it at once solidifies forming pyramidal crystals, probably belonging to the monoclinic system.

Gallium is tough, and may be cut with a knife; the molten metal, when brought on to glass, covers the surface with a bright mirror-like deposit, and oxidizes on exposure to the air. It is not volatile at a red-heat, and only a thin film of oxide is formed on the volatile surface. Its specific gravity is 5.9, and its specific heat 0.080. It is easily soluble in dilute hydrochloric acid and caustic potash with evolution of hydrogen. It is scarcely attacked by dilute nitric acid in the cold, but on heating it slowly dissolves with evolution of red vapours. If a neutral solution of gallium chloride be warmed with zinc, gallium oxide or a basic salt separates out.

Gallium Oxide, Ga_2O_3 , is a white precipitate insoluble in water, but readily soluble in potash, and somewhat less so in ammonia.

¹ *Compt. Rend.* lxxxvi. 475.

SALTS OF GALLIUM.

311 *Gallium Chloride*, Ga_2Cl_6 , is very deliquescent. It dissolves in a small quantity of water to form a clear liquid, which on the further addition of water becomes turbid from deposition of a basic salt. The *sulphate* is also very soluble, but non-deliquescent. It combines with sulphate of ammonium to form an alum $\text{Ga}_2(\text{SO}_4)_3 + (\text{NH}_4)_2\text{SO}_4 + 24\text{H}_2\text{O}$, which crystallizes in combinations of the cube and octohedron. If its solution be boiled a precipitate is produced consisting probably of basic sulphate. Gallium nitrate is also a soluble well crystallizable salt.

The best means of detecting gallium is by the spark-spectrum of the chloride or other salt. This consists of two violet lines, of which the brightest, $\text{Ga}\alpha$, lies a little more towards the blue than the line $\text{In}\beta$, and the second $\text{Ga}\beta$ rather more towards the violet than $\text{K}\beta$. In the non-luminous gas-flame the chloride gives only a very slight indication of the line $\text{Ga}\alpha$.

The atomic weight of gallium has been determined by Lecoq de Boisbaudran¹ by igniting the alum, and also by dissolving the metal in nitric acid and igniting the residue, the oxide obtained in both cases being weighed. The first determination gave the atomic weight 69.86, and the second 69.74.

¹ *Bull. Soc. Chim.* xxix. 9.